

Kawasaki Ninja ZX-10R



Motorcycle Service Manual

www.zxforums.com

Quick Reference Guide

General Information	1
Periodic Maintenance	2
Fuel System (DFI)	3
Cooling System	4
Engine Top End	5
Clutch	6
Engine Lubrication System	7
Engine Removal/Installation	8
Crankshaft/Transmission	9
Wheels/Tires	10
Final Drive	11
Brakes	12
Suspension	13
Steering	14
Frame	15
Electrical System	16
Appendix	17

This quick reference guide will assist you in locating a desired topic or procedure.

- Bend the pages back to match the black tab of the desired chapter number with the black tab on the edge at each table of contents page.
- Refer to the sectional table of contents for the exact pages to locate the specific topic required.

www.zxforums.com



Kawasaki

Ninja ZX-10R

www.zxforums.com

Motorcycle Service Manual

All rights reserved. No parts of this publication may be reproduced, stored in a retrieval system, or transmitted in any form or by any means, electronic mechanical photocopying, recording or otherwise, without the prior written permission of Quality Division/Consumer Products & Machinery Company/Kawasaki Heavy Industries, Ltd., Japan.

No liability can be accepted for any inaccuracies or omissions in this publication, although every possible care has been taken to make it as complete and accurate as possible.

The right is reserved to make changes at any time without prior notice and without incurring an obligation to make such changes to products manufactured previously. See your Motorcycle dealer for the latest information on product improvements incorporated after this publication.

All information contained in this publication is based on the latest product information available at the time of publication. Illustrations and photographs in this publication are intended for reference use only and may not depict actual model component parts.

A	ampere(s)	lb	pound(s)
ABDC	after bottom dead center	m	meter(s)
AC	alternating current	min	minute(s)
ATDC	after top dead center	N	newton(s)
BBDC	before bottom dead center	Pa	pascal(s)
BDC	bottom dead center	PS	horsepower
BTDC	before top dead center	psi	pound(s) per square inch
°C	degree(s) Celsius	r	revolution
DC	direct current	rpm	revolution(s) per minute
F	farad(s)	TDC	top dead center
°F	degree(s) Fahrenheit	TIR	total indicator reading
ft	foot, feet	V	volt(s)
g	gram(s)	W	watt(s)
h	hour(s)	Ω	ohm(s)
L	liter(s)		

COUNTRY AND AREA CODES

AT	Austria	FR	France
AU	Australia	GB	United Kingdom
CA	Canada	MY	Malaysia
CAL	California	US	United States
CH	Switzerland	WVTA	Whole Vehicle Type Approval
DE	Germany		

EMISSION CONTROL INFORMATION

To protect the environment in which we all live, Kawasaki has incorporated crankcase emission (1) and exhaust emission (2) control systems in compliance with applicable regulations of the United States Environmental Protection Agency and California Air Resources Board. Additionally, Kawasaki has incorporated an evaporative emission control system (3) in compliance with applicable regulations of the California Air Resources Board on vehicles sold in California only.

1. Crankcase Emission Control System

This system eliminates the release of crankcase vapors into the atmosphere. Instead, the vapors are routed through an oil separator to the inlet side of the engine. While the engine is operating, the vapors are drawn into combustion chamber, where they are burned along with the fuel and air supplied by the fuel injection system.

2. Exhaust Emission Control System

This system reduces the amount of pollutants discharged into the atmosphere by the exhaust of this motorcycle. The fuel, ignition, and exhaust systems of this motorcycle have been carefully designed and constructed to ensure an efficient engine with low exhaust pollutant levels.

The exhaust system of this model motorcycle manufactured primarily for sale in California includes a catalytic converter system.

3. Evaporative Emission Control System

Vapors caused by fuel evaporation in the fuel system are not vented into the atmosphere. Instead, fuel vapors are routed into the running engine to be burned, or stored in a canister when the engine is stopped. Liquid fuel is caught by a vapor separator and returned to the fuel tank.

The Clean Air Act, which is the Federal law covering motor vehicle pollution, contains what is commonly referred to as the Act's "tampering provisions".

"Sec. 203(a) The following acts and the causing thereof are prohibited..."

(3)(A) for any person to remove or render inoperative any device or element of design installed on or in a motor vehicle or motor vehicle engine in compliance with regulations under this title prior to its sale and delivery to the ultimate purchaser, or for any manufacturer or dealer knowingly to remove or render inoperative any such device or element of design after such sale and delivery to the ultimate purchaser.

(3)(B) for any person engaged in the business of repairing, servicing, selling, leasing, or trading motor vehicles or motor vehicle engines, or who operates a fleet of motor vehicles knowingly to remove or render inoperative any device or element of design installed on or in a motor vehicle or motor vehicle engine in compliance with regulations under this title following its sale and delivery to the ultimate purchaser..."

NOTE

○The phrase "remove or render inoperative any device or element of design" has been generally interpreted as follows.

1. Tampering does not include the temporary removal or rendering inoperative of devices or elements of design in order to perform maintenance.
2. Tampering could include.
 - a. Maladjustment of vehicle components such that the emission standards are exceeded.
 - b. Use of replacement parts or accessories which adversely affect the performance or durability of the motorcycle.
 - c. Addition of components or accessories that result in the vehicle exceeding the standards.
 - d. Permanently removing, disconnecting, or rendering inoperative any component or element of design of the emission control systems.

WE RECOMMEND THAT ALL DEALERS OBSERVE THESE PROVISIONS OF FEDERAL LAW, THE VIOLATION OF WHICH IS PUNISHABLE BY CIVIL PENALTIES NOT EXCEEDING \$10 000 PER VIOLATION.

TAMPERING WITH NOISE CONTROL SYSTEM PROHIBITED

Federal law prohibits the following acts or the causing thereof. (1) The removal or rendering inoperative by any person other than for purposes of maintenance, repair, or replacement, of any device or element of design incorporated into any new vehicle for the purpose of noise control prior to its sale or delivery to the ultimate purchaser or while it is in use, or (2) the use of the vehicle after such device or element of design has been removed or rendered inoperative by any person.

Among those acts presumed to constitute tampering are the acts listed below.

- Replacement of the original exhaust system or muffler with a component not in compliance with Federal regulations.
- Removal of the muffler(s) or any internal portion of the muffler(s).
- Removal of the air box or air box cover.
- Modifications to the muffler(s) or air inlet system by cutting, drilling, or other means if such modifications result in increased noise levels.

www.zxforums.com

Foreword

This manual is designed primarily for use by trained mechanics in a properly equipped shop. However, it contains enough detail and basic information to make it useful to the owner who desires to perform his own basic maintenance and repair work. A basic knowledge of mechanics, the proper use of tools, and workshop procedures must be understood in order to carry out maintenance and repair satisfactorily. Whenever the owner has insufficient experience or doubts his ability to do the work, all adjustments, maintenance, and repair should be carried out only by qualified mechanics.

In order to perform the work efficiently and to avoid costly mistakes, read the text, thoroughly familiarize yourself with the procedures before starting work, and then do the work carefully in a clean area. Whenever special tools or equipment are specified, do not use makeshift tools or equipment. Precision measurements can only be made if the proper instruments are used, and the use of substitute tools may adversely affect safe operation.

For the duration of the warranty period, we recommend that all repairs and scheduled maintenance be performed in accordance with this service manual. Any owner maintenance or repair procedure not performed in accordance with this manual may void the warranty.

To get the longest life out of your vehicle.

- Follow the Periodic Maintenance Chart in the Service Manual.
- Be alert for problems and non-scheduled maintenance.
- Use proper tools and genuine Kawasaki Motorcycle parts. Special tools, gauges, and testers that are necessary when servicing Kawasaki motorcycles are introduced by the Service Manual. Genuine parts provided as spare parts are listed in the Parts Catalog.
- Follow the procedures in this manual carefully. Don't take shortcuts.
- Remember to keep complete records of maintenance and repair with dates and any new parts installed.

How to Use This Manual

In this manual, the product is divided into its major systems and these systems make up the manual's chapters. The Quick Reference

Guide shows you all of the product's system and assists in locating their chapters. Each chapter in turn has its own comprehensive Table of Contents.

For example, if you want ignition coil information, use the Quick Reference Guide to locate the Electrical System chapter. Then, use the Table of Contents on the first page of the chapter to find the Ignition Coil section.

Whenever you see these WARNING and CAUTION symbols, heed their instructions! Always follow safe operating and maintenance practices.

WARNING

This warning symbol identifies special instructions or procedures which, if not correctly followed, could result in personal injury, or loss of life.

CAUTION

This caution symbol identifies special instructions or procedures which, if not strictly observed, could result in damage to or destruction of equipment.

This manual contains four more symbols (in addition to WARNING and CAUTION) which will help you distinguish different types of information.

NOTE

○ *This note symbol indicates points of particular interest for more efficient and convenient operation.*

- Indicates a procedural step or work to be done.
- Indicates a procedural sub-step or how to do the work of the procedural step it follows. It also precedes the text of a NOTE.
- ★ Indicates a conditional step or what action to take based on the results of the test or inspection in the procedural step or sub-step it follows.

In most chapters an exploded view illustration of the system components follows the Table of Contents. In these illustrations you will find the instructions indicating which parts require specified tightening torque, oil, grease or a locking agent during assembly.

www.zxforums.com

General Information

Table of Contents

Before Servicing	1-2
Model Identification.....	1-7
General Specifications.....	1-9
Unit Conversion Table	1-12

www.zxforums.com

Before Servicing

Before starting to perform an inspection service or carry out a disassembly and reassembly operation on a motorcycle, read the precautions given below. To facilitate actual operations, notes, illustrations, photographs, cautions, and detailed descriptions have been included in each chapter wherever necessary. This section explains the items that require particular attention during the removal and reinstallation or disassembly and reassembly of general parts.

Especially note the following.

Battery Ground

Before completing any service on the motorcycle, disconnect the battery cables from the battery to prevent the engine from accidentally turning over. Disconnect the ground cable (-) first and then the positive (+). When completed with the service, first connect the positive (+) cable to the positive (+) terminal of the battery then the negative (-) cable to the negative terminal.

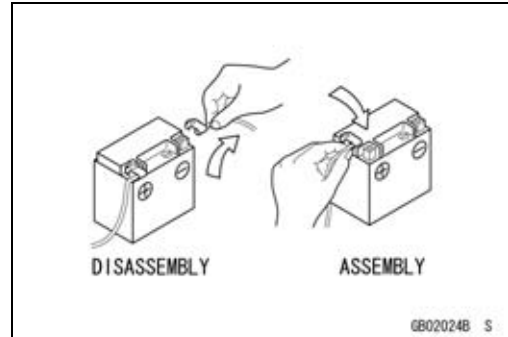

Edges of Parts

Lift large or heavy parts wearing gloves to prevent injury from possible sharp edges on the parts.

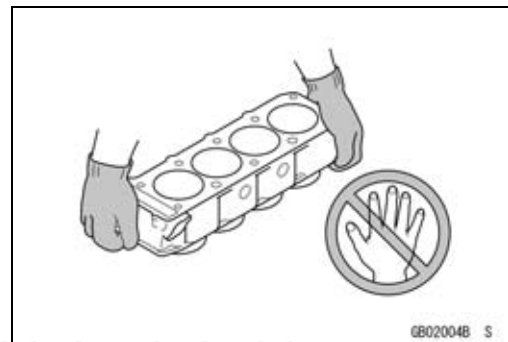

Solvent

Use a high-flash point solvent when cleaning parts. High-flash point solvent should be used according to directions of the solvent manufacturer.

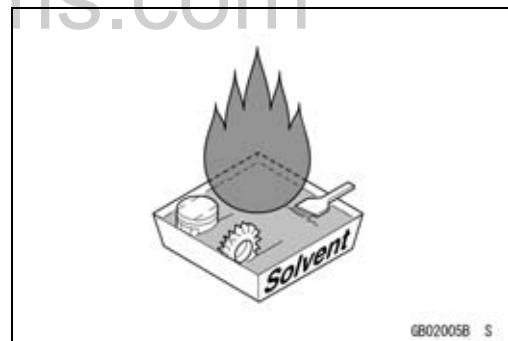

Cleaning vehicle before disassembly

Clean the vehicle thoroughly before disassembly. Dirt or other foreign materials entering into sealed areas during vehicle disassembly can cause excessive wear and decrease performance of the vehicle.

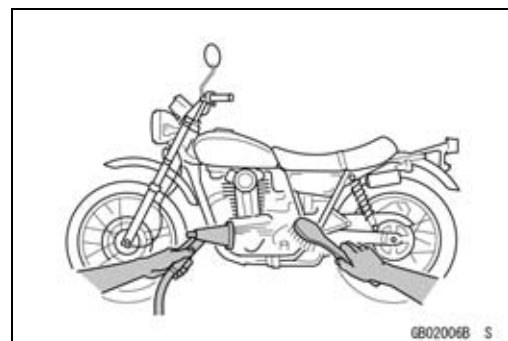

Before Servicing

Arrangement and Cleaning of Removed Parts

Disassembled parts are easy to confuse. Arrange the parts according to the order the parts were disassembled and clean the parts in order prior to assembly.

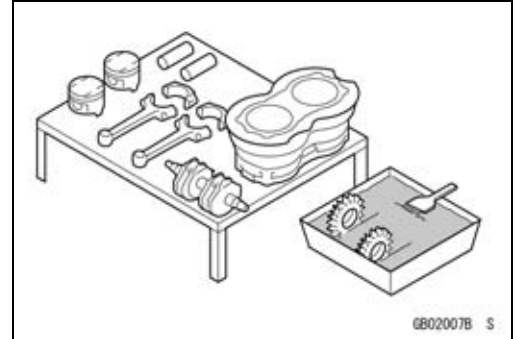

Storage of Removed Parts

After all the parts including subassembly parts have been cleaned, store the parts in a clean area. Put a clean cloth or plastic sheet over the parts to protect from any foreign materials that may collect before re-assembly.

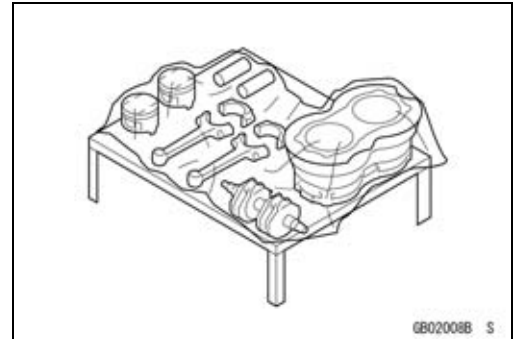

Inspection

Reuse of worn or damaged parts may lead to serious accident. Visually inspect removed parts for corrosion, discoloration, or other damage. Refer to the appropriate sections of this manual for service limits on individual parts. Replace the parts if any damage has been found or if the part is beyond its service limit.

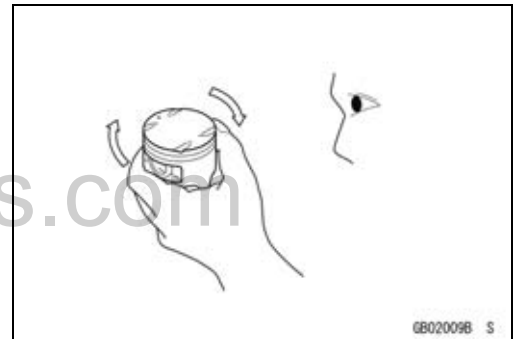

Replacement Parts

Replacement Parts must be KAWASAKI genuine or recommended by KAWASAKI. Gaskets, O-rings, oil seals, grease seals, circlips or cotter pins must be replaced with new ones whenever disassembled.

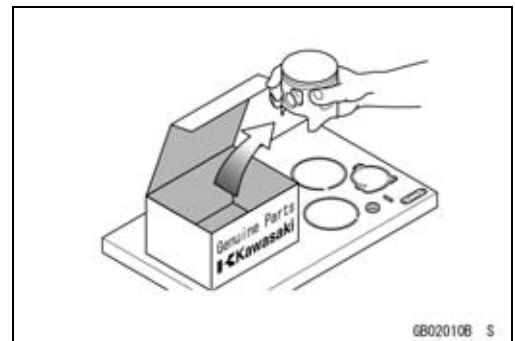

Assembly Order

In most cases assembly order is the reverse of disassembly, however, if assembly order is provided in this Service Manual, follow the procedures given.

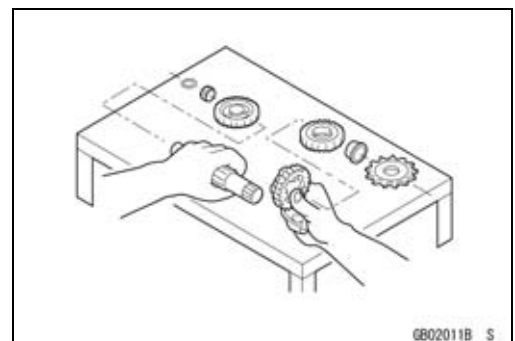

Before Servicing

Tightening Sequence

Generally, when installing a part with several bolts, nuts, or screws, start them all in their holes and tighten them to a snug fit. Then tighten them according to the specified sequence to prevent case warpage or deformation which can lead to malfunction. Conversely when loosening the bolts, nuts, or screws, first loosen all of them by about a quarter turn and then remove them. If the specified tightening sequence is not indicated, tighten the fasteners alternating diagonally.

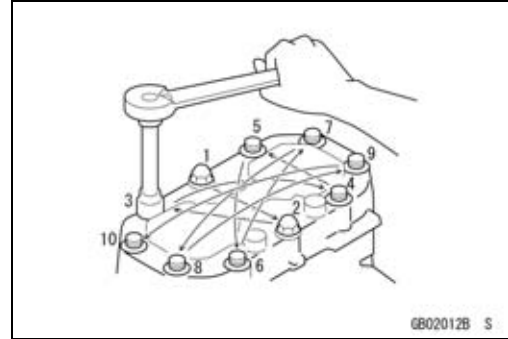

GB02012B S

Tightening Torque

Incorrect torque applied to a bolt, nut, or screw may lead to serious damage. Tighten fasteners to the specified torque using a good quality torque wrench.

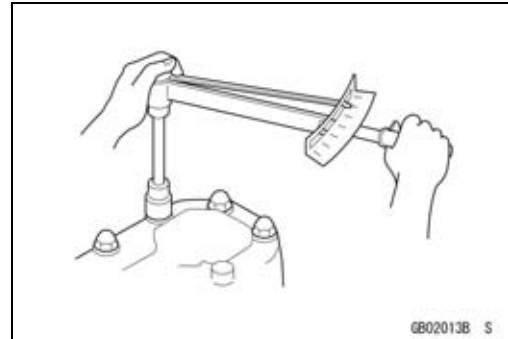

GB02013B S

Force

Use common sense during disassembly and assembly, excessive force can cause expensive or hard to repair damage. When necessary, remove screws that have a non-permanent locking agent applied using an impact driver. Use a plastic-faced mallet whenever tapping is necessary.

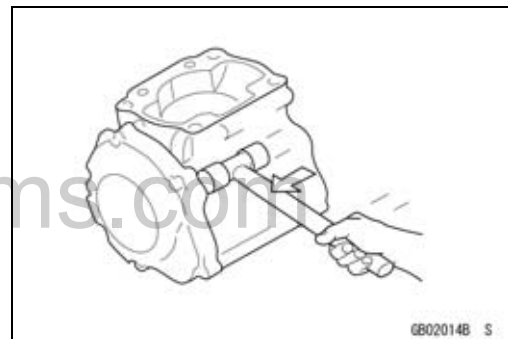

GB02014B S

Gasket, O-ring

Hardening, shrinkage, or damage of both gaskets and O-rings after disassembly can reduce sealing performance. Remove the old gaskets and clean the sealing surfaces thoroughly so that no gasket material or other material remains. Install the new gaskets and replace the used O-rings when re-assembling

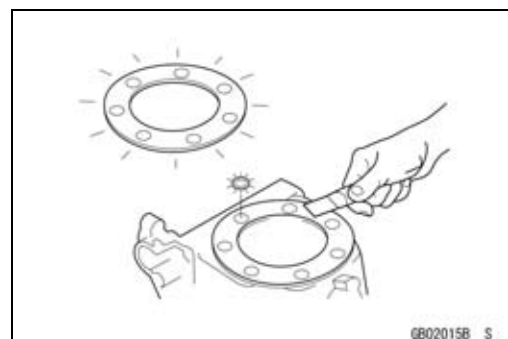

GB02015B S

Liquid Gasket, Non-permanent Locking Agent

For applications that require Liquid Gasket or a Non-permanent Locking Agent, clean the surfaces so that no oil residue remains before applying liquid gasket or non-permanent locking agent. Do not apply them excessively. Excessive application can clog oil passages and cause serious damage.



GB02016B S

Before Servicing

Press

For items such as bearings or oil seals that must be pressed into place, apply small amount of oil to the contact area. Be sure to maintain proper alignment and use smooth movements when installing.

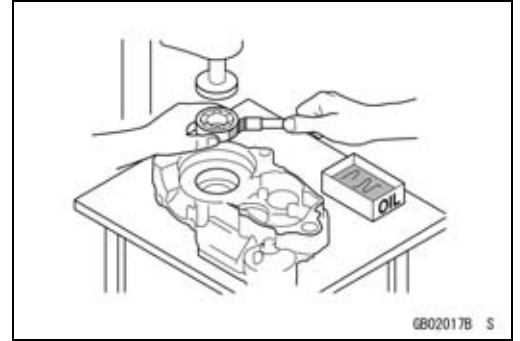

Ball Bearing and Needle Bearing

Do not remove pressed ball or needle unless removal is absolutely necessary. Replace with new ones whenever removed. Press bearings with the manufacturer and size marks facing out. Press the bearing into place by putting pressure on the correct bearing race as shown.

Pressing the incorrect race can cause pressure between the inner and outer race and result in bearing damage.

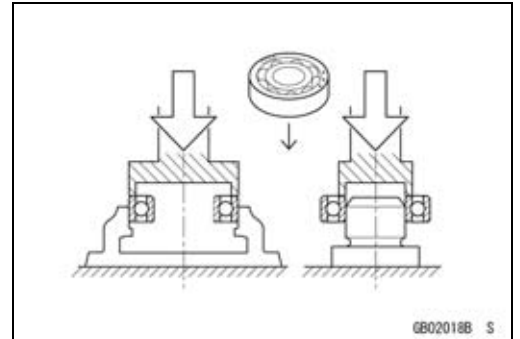

Oil Seal, Grease Seal

Do not remove pressed oil or grease seals unless removal is necessary. Replace with new ones whenever removed. Press new oil seals with manufacture and size marks facing out. Make sure the seal is aligned properly when installing.

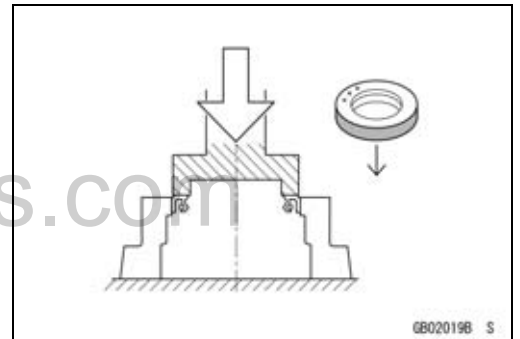

Apply specified grease to the lip of seal before installing the seal.

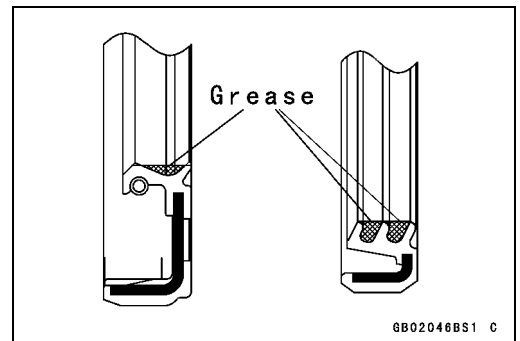

Circlips, Cotter Pins

Replace the circlips or cotter pins that were removed with new ones. Take care not to open the clip excessively when installing to prevent deformation.

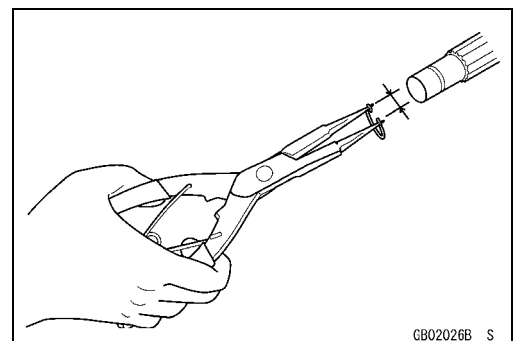

Before Servicing

Lubrication

It is important to lubricate rotating or sliding parts during assembly to minimize wear during initial operation. Lubrication points are called out throughout this manual, apply the specific oil or grease as specified.

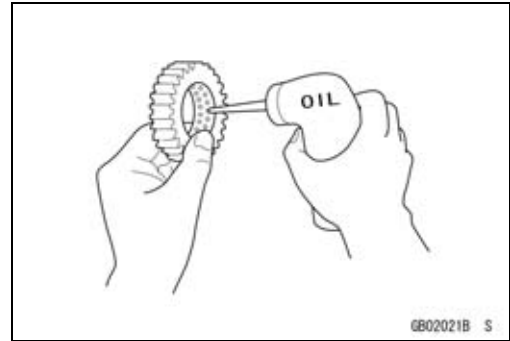

Direction of Engine Rotation

When rotating the crankshaft by hand, the free play amount of rotating direction will affect the adjustment. Rotate the crankshaft to positive direction (clockwise viewed from output side).

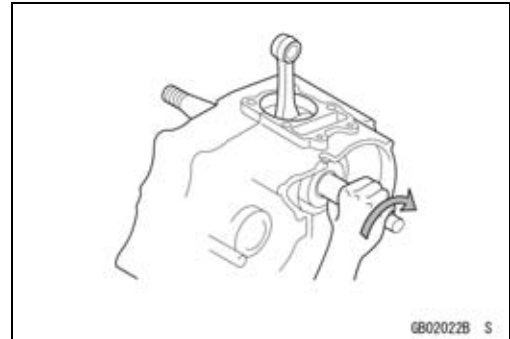

Electrical Wires

A two-color wire is identified first by the primary color and then the stripe color. Unless instructed otherwise, electrical wires must be connected to those of the same color.

www.zxforums.com

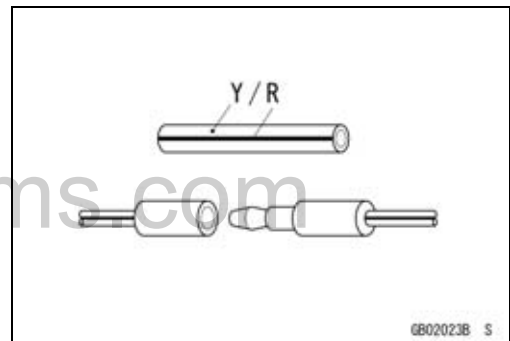

Instrument

Use a meter that has enough accuracy for an accurate measurement. Read the manufacture's instructions thoroughly before using the meter. Incorrect values may lead to improper adjustments.

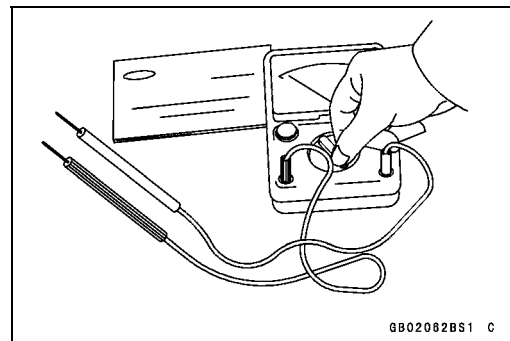

Model Identification

ZX1000D6F (Europe) Left Side View



ZX1000D6F (Europe) Right Side View



Model Identification

ZX1000D6F (United States and Canada) Left Side View



ZX1000D6F (United States and Canada) Right Side View



Frame Number



Engine Number



General Specifications

Items	ZX1000D6F (Ninja ZX-10R)
Dimensions	
Overall Length	2 065 mm (81.3 in.)
Overall Width	(CA), (CAL), (US) 730 mm (28.7 in.) 705 mm (27.8 in.)
Overall Height	1 130 mm (44.5 in.)
Wheelbase	1 390 mm (54.7 in.)
Road Clearance	120 mm (4.7 in.)
Seat Height	825 mm (32.5 in.)
Dry Mass	175 kg (386 lb)
Curb Mass:	
Front	102 kg (225 lb)
Rear	100 kg (221 lb)
Fuel Tank Capacity	17 L (4.5 US gal)
Performance	
Minimum Turning Radius	3.3 m (10.8 ft)
Engine	
Type	4-stroke, DOHC, 4-cylinder
Cooling System	Liquid-cooled
Bore and Stroke	76.0 × 55.0 mm (3.0 × 2.2 in.)
Displacement	998 mL (60.9 cu in.)
Compression Ratio	12.7 : 1
Maximum Horsepower	128.7 kW (175 PS) @11 700 r/min (rpm), (FR) 78.2 kW (106 PS) @10 500 r/min (rpm), (AU) 128.7 kW (175 PS) @11 500 r/min (rpm), (MY) 120.5 kW (164 PS) @10 000 r/min (rpm), (CA), (CAL), (US) — — —
Maximum Torque	115 N·m (11.7 kgf·m, 85 ft·lb) @9 500 r/min (rpm), (FR) 86 N·m (8.8 kgf·m, 63 ft·lb) @5 200 r/min (rpm), (CA), (CAL), (US) — — —
Carburetion System	FI (Fuel injection), MIKUNI 43EIDW × 4
Starting System	Electric starter
Ignition System	Battery and coil (transistorized)
Timing Advance	Electronically advanced (digital igniter in ECU)
Ignition Timing	From 10° BTDC @1 100 r/min (rpm)
Spark Plug	NGK CR9EIA-9
Cylinder Numbering Method	Left to right, 1-2-3-4
Firing Order	1-2-4-3
Valve Timing:	
Inlet:	
Open	46° BTDC
Close	74° ABDC
Duration	300°
Exhaust:	
Open	66° BBDC
Close	46° ATDC

General Specifications

Items	ZX1000D6F (Ninja ZX-10R)
Duration Lubrication System Engine Oil: Type Viscosity Capacity	292° Forced lubrication (wet sump with cooler) API SE, SF or SG API SH, SJ or SL with JASO MA SAE10W-40 4.0 L (4.2 US qt)
Drive Train Primary Reduction System: Type Reduction Ratio Clutch Type Transmission: Type Gear Ratios: 1st 2nd 3rd 4th 5th 6th Final Drive System: Type Reduction Ratio Overall Drive Ratio	Gear 1.611 (87/54) Wet multi disc 6-speed, constant mesh, return shift 2.533 (38/15) 2.053 (39/19) 1.737 (33/19) 1.524 (32/21) 1.381 (29/21) 1.304 (30/23) Chain drive 2.353 (40/17) 4.945 @Top gear
Frame Type Caster (Rake Angle) Trail Front Tire: Type Size Rear Tire: Type Size Rim Size: Front Rear Front Suspension: Type Wheel Travel Rear Suspension: Type Wheel Travel	Tubular, diamond 24.5° 102 mm (4.0 in.) Tubeless 120/70 ZR17 M/C (58 W) Tubeless 190/55 ZR17 M/C (75 W) 17 × 3.50 17 × 6.00 Telescopic fork (upside-down) 120 mm (4.7 in.) Swingarm (uni-trak) 125 mm (4.9 in.)

General Specifications

Items	ZX1000D6F (Ninja ZX-10R)
Brake Type: Front Rear	Dual discs Single disc
Electrical Equipment Battery Headlight: Type Bulb: High Low Tail/Brake Light Alternator: Type Rated Output	12 V 10 Ah Semi-sealed beam 12 V 55 W + 65 W (quartz-halogen) 12 V 55 W (quartz-halogen) 12 V 0.5/4.1 W (LED) Three-phase AC 31 A/14 V @5 000 r/min (rpm)

Specifications subject to change without notice, and may not apply to every country.

www.zxforums.com

Unit Conversion Table

Prefixes for Units

Prefix	Symbol	Power
mega	M	× 1 000 000
kilo	k	× 1 000
centi	c	× 0.01
milli	m	× 0.001
micro	μ	× 0.000001

Units of Mass

kg	×	2.205	=	lb
g	×	0.03527	=	oz

Units of Volume

L	×	0.2642	=	gal (US)
L	×	0.2200	=	gal (imp)
L	×	1.057	=	qt (US)
L	×	0.8799	=	qt (imp)
L	×	2.113	=	pint (US)
L	×	1.816	=	pint (imp)
mL	×	0.03381	=	oz (US)
mL	×	0.02816	=	oz (imp)
mL	×	0.06102	=	cu in

Units of Force

N	×	0.1020	=	kg
N	×	0.2248	=	lb

kg	×	9.807	=	N
kg	×	2.205	=	lb

Units of Length

km	×	0.6214	=	mile
m	×	3.281	=	ft
mm	×	0.03937	=	in

Units of Torque

N·m	×	0.1020	=	kgf·m
N·m	×	0.7376	=	ft·lb
N·m	×	8.851	=	in·lb

kgf·m	×	9.807	=	N·m
kgf·m	×	7.233	=	ft·lb
kgf·m	×	86.80	=	in·lb

Units of Pressure

kPa	×	0.01020	=	kgf/cm ²
kPa	×	0.1450	=	psi
kPa	×	0.7501	=	cmHg

kgf/cm ²	×	98.07	=	kPa
kgf/cm ²	×	14.22	=	psi
cmHg	×	1.333	=	kPa

Units of Speed

km/h	×	0.6214	=	mph
------	---	--------	---	-----

Units of Power

kW	×	1.360	=	PS
kW	×	1.341	=	HP

PS	×	0.7355	=	kW
PS	×	0.9863	=	HP

Units of Temperature

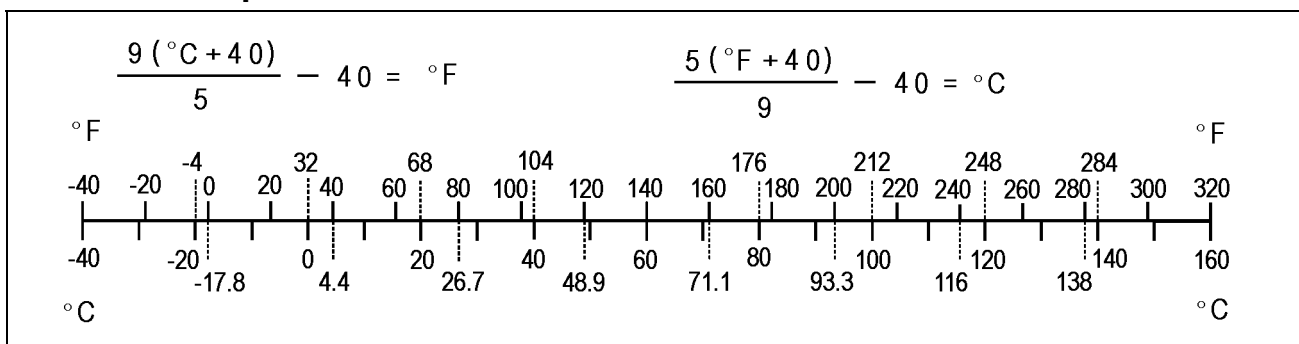

Periodic Maintenance

Table of Contents

Periodic Maintenance Chart	2-3
Torque and Locking Agent.....	2-6
Specifications	2-13
Special Tools	2-15
Maintenance Procedure	2-16
Fuel System (DFI).....	2-16
Throttle Control System Inspection.....	2-16
Engine Vacuum Synchronization Inspection.....	2-16
Idle Speed Inspection	2-19
Idle Speed Adjustment.....	2-20
Fuel Hose Inspection (fuel leak, damage, installation condition).....	2-20
Evaporative Emission Control System (California Model)	2-21
Evaporative Emission Control System Inspection	2-21
Cooling System.....	2-22
Coolant Level Inspection.....	2-22
Radiator Hose and Pipe Inspection (coolant leak, damage, installation condition)	2-22
Engine Top End	2-22
Valve Clearance Inspection	2-22
Valve Clearance Adjustment.....	2-24
Air Suction System	2-26
Air Suction System Damage Inspection.....	2-26
Clutch.....	2-27
Clutch Operation Inspection	2-27
Wheels/Tires.....	2-28
Air Pressure Inspection.....	2-28
Wheel/Tire Damage Inspection.....	2-28
Tire Tread Wear Inspection	2-28
Wheel Bearing Damage Inspection	2-29
Drive Train	2-30
Drive Chain Lubrication Condition Inspection	2-30
Drive Chain Slack Inspection	2-30
Drive Chain Slack Adjustment	2-31
Wheel Alignment Inspection	2-32
Drive Chain Wear Inspection	2-32
Chain Guide Wear Inspection	2-33
Brake System	2-33
Brake Fluid Leak (Brake Hose and Pipe) Inspection	2-33
Brake Hose Damage and Installation Condition Inspection.....	2-33
Brake Operation Inspection	2-33
Brake Fluid Level Inspection.....	2-34
Brake Pad Wear Inspection	2-34
Brake Light Switch Operation Inspection	2-34
Suspensions	2-35
Front Forks/Rear Shock Absorber Operation Inspection	2-35
Front Fork Oil Leak Inspection.....	2-36
Rear Shock Absorber Oil Leak Inspection	2-36
Rocker Arm Operation Inspection.....	2-36
Tie-Rod Operation Inspection	2-36
Steering System	2-37
Steering Play Inspection	2-37

Steering Play Adjustment.....	2-37
Steering Stem Bearing Lubrication	2-38
Steering Damper Oil Leak Inspection	2-38
Electrical System	2-39
Lights and Switches Operation Inspection.....	2-39
Headlight Aiming Inspection	2-41
Sidestand Switch Operation Inspection	2-42
Engine Stop Switch Operation Inspection.....	2-43
Others	2-44
Chassis Parts Lubrication	2-44
Bolts, Nuts and Fasteners Tightness Inspection.....	2-45
Replacement Parts	2-47
Air Cleaner Element Replacement.....	2-47
Fuel Hose Replacement	2-48
Coolant Change	2-49
Radiator Hose and O-ring Replacement.....	2-52
Engine Oil Change.....	2-53
Oil Filter Replacement	2-53
Brake Hose and Pipe Replacement.....	2-54
Brake Fluid Change	2-54
Master Cylinder Rubber Parts Replacement	2-56
Caliper Rubber Parts Replacement	2-57
Spark Plug Replacement	2-60

www.zxforums.com

Periodic Maintenance Chart

The scheduled maintenance must be done in accordance with this chart to keep the motorcycle in good running condition. **The initial maintenance is vitally important and must not be neglected.**

Periodic Inspection

INSPECTION	FREQUENCY	Whichever comes first ↓ Every	* ODOMETER READING × 1 000 km (× 1 000 mile)						See Page
			1 (0.6)	6 (4)	12 (7.5)	18 (12)	24 (15)	30 (20)	
Fuel System									
Throttle control system (play, smooth return, no drag)-inspect	year	•		•		•		•	2-16
Engine vacuum synchronization-inspect				•		•		•	2-16
Idle speed-inspect		•		•		•		•	2-19
Fuel leak (fuel hose and pipe)-inspect	year	•		•		•		•	2-20
Fuel hose and pipe damage-inspect	year	•		•		•		•	2-20
Fuel hose and pipe installation condition-inspect	year	•		•		•		•	2-20
Evaporative Emission Control System (CAL)									
Evaporative emission control system function-inspect			•	•	•	•	•	•	2-21
Cooling System									
Coolant level-inspect		•		•		•		•	2-22
Coolant leak (radiator hose and pipe)-inspect	year	•		•		•		•	2-22
Radiator hose damage-inspect	year	•		•		•		•	2-22
Radiator hose installation condition -inspect	year	•		•		•		•	2-22
Engine Top End									
Valve clearance-inspect						•			2-22
Air Suction System									
Air suction system damage-inspect				•		•		•	2-26
Clutch									
Clutch operation (play, disengagement, engagement)-inspect		•		•		•		•	2-27
Wheels and Tires									
Tire air pressure-inspect	year			•		•		•	2-28
Wheel/tire damage-inspect				•		•		•	2-28
Tire tread wear, abnormal wear-inspect				•		•		•	2-28
Wheel bearing damage-inspect	year			•		•		•	2-29
Drive Train									
Drive chain lubrication condition-inspect #	Every 600 km (400 mile)								2-30
Drive chain slack-inspect #	Every 1 000 km (600 mile)								2-30
Drive chain wear-inspect #				•		•		•	2-32
Drive chain guide wear-inspect				•		•		•	2-33

Periodic Maintenance Chart

INSPECTION	FREQUENCY	* ODOMETER READING							See Page
		Whichever comes first ↓ Every	1 (0.6)	6 (4)	12 (7.5)	18 (12)	24 (15)	30 (20)	
Brake System									
Brake fluid leak (brake hose and pipe)-inspect	year	•	•	•	•	•	•	•	2-33
Brake hose and pipe damage-inspect	year	•	•	•	•	•	•	•	2-33
Brake pad wear-inspect #			•	•	•	•	•	•	2-34
Brake hose installation condition-inspect	year	•	•	•	•	•	•	•	2-33
Brake fluid level-inspect	6 months	•	•	•	•	•	•	•	2-34
Brake operation (effectiveness, play, no drag)-inspect	year	•	•	•	•	•	•	•	2-33
Brake light switch operation-inspect		•	•	•	•	•	•	•	2-34
Suspensions									
Front forks/rear shock absorber operation (damping and smooth stroke)-inspect				•		•		•	2-35
Front forks/rear shock absorber oil leak-inspect	year			•		•		•	2-36
Rocker arm operation-inspect				•		•		•	2-36
Tie-Rods operation-inspect				•		•		•	2-36
Steering System									
Steering play-inspect	year	•		•		•		•	2-37
Steering stem bearings-lubricate	2 years					•			2-38
Steering damper oil leak-inspect			•	•	•	•	•	•	2-38
Electrical System									
Lights and switches operation-inspect	year			•		•		•	2-39
Headlight aiming-inspect	year			•		•		•	2-41
Sidestand switch operation-inspect	year			•		•		•	2-42
Engine stop switch operation-inspect	year			•		•		•	2-43
Others									
Chassis parts-lubricate	year			•		•		•	2-44
Bolts and nuts tightness-inspect		•		•		•		•	2-45

*: For higher odometer readings, repeat at the frequency interval established here.

#: Service more frequently when operating in severe conditions; dusty, wet, muddy, high speed or frequent starting/stopping.

Periodic Maintenance Chart

Periodic Replacement Parts

CHANGE/REPLACE ITEM	FREQUENCY	* ODOMETER READING × 1 000 km (× 1 000 mile)					See Page
		Whichever come first ↓ Every	1 (0.6)	12 (7.5)	24 (15)	36 (24)	
Air cleaner element #		Every 18 000 km (12 000 mile)					2-47
Fuel hose	4 years					●	2-48
Coolant	3 years				●		2-49
Radiator hose and O-ring	3 years				●		2-52
Engine oil #	year	●	●	●	●	●	2-53
Oil filter	year	●	●	●	●	●	2-53
Brake hose and pipe	4 years					●	2-54
Brake fluid	2 years			●		●	2-54
Rubber parts of master cylinder and caliper	4 years					●	2-56
Spark plug			●	●	●	●	2-60

*: For higher odometer readings, repeat at the frequency interval established here.

#: Service more frequently when operating in severe conditions; dusty, wet, muddy, high speed or frequent starting/stopping.

www.zxforums.com

Torque and Locking Agent

The following tables list the tightening torque for the major fasteners requiring use of a non-permanent locking agent or silicone sealant etc.

Letters used in the "Remarks" column mean:

AL: Tighten the two clamp bolts alternately two times to ensure even tightening torque.

G: Apply grease.

L: Apply a non-permanent locking agent.

MO: Apply molybdenum disulfide oil solution.

(mixture of the engine oil and molybdenum disulfide grease in a weight ratio 10 : 1.)

R: Replacement Parts

S: Follow the specified tightening sequence.

Si: Apply silicone grease (ex. PBC grease).

SS: Apply silicone sealant.

Fastener	Torque			Remarks
	N·m	kgf·m	ft·lb	
Fuel System				
Air Cleaner Element Cover Screws	1.1	0.11	9.7 in·lb	
Air Cleaner Housing Holder Clamp Screws	2.0	0.20	18 in·lb	
Air Cleaner Housing Mounting Bolts	7.0	0.71	62 in·lb	
Air Inlet Duct Mounting Bolts	7.0	0.71	62 in·lb	L
Bypass Screws	0.2	0.02	17 in·lb	
Camshaft Position Sensor Bolt	10	1.0	89 in·lb	
Canister Bracket Mounting Bolt (M5)	4.3	0.44	38 in·lb	
Canister Bracket Mounting Screws (M5)	4.3	0.44	38 in·lb	
Crankshaft Sensor Bolts	6.0	0.61	53 in·lb	L
Delivery Pipe Mounting Screws	5.0	0.51	44 in·lb	
Exhaust Butterfly Valve Actuator Mounting Bolts	0.8	0.08	7 in·lb	
Exhaust Butterfly Valve Actuator Pulley Bolts	5.0	0.51	44 in·lb	
Fuel Pump Bolts	10	1.0	89 in·lb	L, S
Gear Position Switch Screws	3.0	0.31	27 in·lb	L
Inlet Air Pressure Sensor Bracket Screws	3.5	0.36	31 in·lb	
Separator Bracket Mounting Bolts	7.0	0.71	62 in·lb	
Separator/Canister Hose Clamp Bolt	7.0	0.71	62 in·lb	
Speed Sensor Bolt	10	1.0	89 in·lb	
Throttle Body Assy Holder Bolts	10	1.0	89 in·lb	
Throttle Body Assy Holder Clamp Bolts	2.0	0.20	18 in·lb	
Vehicle-down Sensor Bolts	6.0	0.61	53 in·lb	
Water Temperature Sensor	25	2.5	18	SS
Cooling System				
Coolant By-pass Fitting Bolt	9.0	0.92	80 in·lb	L
Coolant Drain Bolt (Cylinder)	10	1.0	89 in·lb	
Coolant Drain Bolt (Water Pump)	10	1.0	89 in·lb	
Coolant Reserve Tank Mounting Bolts	7.0	0.71	62 in·lb	
Oil Cooler Mounting Bolts	20	2.0	15	
Thermostat Housing Cover Bolts	6.0	0.61	53 in·lb	
Thermostat Housing Mounting Bolts	10	1.0	89 in·lb	
Radiator Bracket Mounting Bolt	7.0	0.71	62 in·lb	

Torque and Locking Agent

Fastener	Torque			Remarks
	N·m	kgf·m	ft·lb	
Radiator Lower Bolt	7.0	0.71	62 in·lb	
Radiator Upper Bolt	7.0	0.71	62 in·lb	
Water Hose Clamp Screws	2.0	0.20	18 in·lb	
Water Hose Fitting Bolts	10	1.0	89 in·lb	
Water Passage Plugs	19.6	2.0	14	L
Water Pump Cover Bolts	10	1.0	89 in·lb	
Water Temperature Sensor	25	2.5	18	SS
Engine Top End				
Air Suction Valve Cover Bolts	10	1.0	89 in·lb	L
Camshaft Cap Bolts	12	1.2	106 in·lb	S
Camshaft Chain Tensioner Cap Bolt	20	2.0	15	
Camshaft Chain Tensioner Mounting Bolts	10	1.0	89 in·lb	
Camshaft Position Sensor Bolt	10	1.0	89 in·lb	
Cam Sprocket Mounting Bolts	15	1.5	11	L
Coolant Drain Plug (Cylinder)	10	1.0	89 in·lb	
Cylinder Head Bolts (M6)	12	1.2	106 in·lb	
Cylinder Head Bolts (M10 New Bolts)	59	6.0	44	MO, S
Cylinder Head Bolts (M10 Used Bolts)	57	5.8	42	MO, S
Cylinder Head Cover Bolts	10	1.0	89 in·lb	
Exhaust Butterfly Valve Cable Adjuster Locknuts	7.0	0.71	62 in·lb	
Exhaust Butterfly Valve Cable Locknuts	7.0	0.71	62 in·lb	
Exhaust Pipe Manifold Mounting Bolts	14	1.4	10	
Front Camshaft Chain Guide Bolt (Upper)	25	2.5	18	
Front Camshaft Chain Guide Bolt (Lower)	12	1.2	106 in·lb	
Front Exhaust Pipe Manifold Holder Nuts	17	1.7	13	
Idle Gear Cover Bolts	10	1.0	89 in·lb	
Middle Exhaust Pipe Clamp Bolt	17	1.7	13	
Middle Exhaust Pipe Stay Bolt	25	2.5	18	
Muffler Body Assembly Nuts	22	2.2	16	
Muffler Body Cover Bolts	7.0	0.71	62 in·lb	
Muffler Body Mounting Bolts	25	2.5	18	
Oxygen Sensors (Europe Models)	25	2.5	18	
Rear Exhaust Pipe Clamp Bolt	17	1.7	13	
Right Engine Bracket Bolts (Cylinder Head Side)	10	1.0	89 in·lb	L
Spark Plugs	13	1.3	115 in·lb	
Starter Clutch Bolt Cap	–	–	–	Hand-tighten
Starter Clutch Cover Bolts (M6, L = 30 mm)	10	1.0	89 in·lb	
Starter Clutch Cover Bolts (M6, L = 20 mm)	10	1.0	89 in·lb	
Throttle Body Assy Holder Bolts	10	1.0	89 in·lb	S
Throttle Body Assy Holder Clamp Bolts	2.0	0.20	18 in·lb	S
Timing Inspection Cap	–	–	–	Hand-tighten
Upper Camshaft Chain Guide Bolts	12	1.2	106 in·lb	S
Water Passage Plugs	19.6	2.0	14	

Torque and Locking Agent

Fastener	Torque			Remarks
	N·m	kgf·m	ft·lb	
Clutch				
Clutch Cover Mounting Bolts	10	1.0	89 in·lb	S
Clutch Hub Nut	130	13.3	96	R
Clutch Lever Clamp Bolts	7.8	0.80	69 in·lb	S
Clutch Spring Bolts	9.8	1.0	87 in·lb	
Oil Filler Plug	–	–	–	Hand-tighten
Sub Clutch Hub Bolts	25	2.5	18	L
Engine Lubrication System				
Engine Oil Drain Bolt	20	2.0	15	
Oil Cooler Mounting Bolts	20	2.0	15	L
Oil Filter	31	3.2	23	EO, R
Oil Cooler/Oil Filter Case Mounting Bolts	20	2.0	15	L
Oil Filter Pipe	35	3.6	26	L
Oil Pan Bolts	10	1.0	89 in·lb	
Oil Passage Plugs	20	2.0	15	L
Oil Pressure Relief Valve	15	1.5	11	L
Oil Pressure Switch	15	1.5	11	SS
Oil Pressure Switch Terminal Bolt	1.5	0.15	13 in·lb	G
Oil Pump Cover Bolts	10	1.0	89 in·lb	
Oil Pump Gear Bolts	10	1.0	89 in·lb	L
Engine Removal/Installation				
Adjusting Collar Locknut	49	5.0	36	S
Left Engine Bracket Bolts (M10, L = 30 mm)	44	4.5	32	S
Left Front Engine Mounting Bolt (M10, L = 42 mm)	44	4.5	32	S
Lower Engine Mounting Bolt	9.8	1.0	87 in·lb	S
Lower Engine Mounting Nut	44	4.5	32	S
Middle Engine Mounting Bolt	9.8	1.0	87 in·lb	S
Middle Engine Mounting Nut	44	4.5	32	S
Right Engine Bracket Bolt (M10, L = 35 mm)	44	4.5	32	S
Right Engine Bracket Bolts (M10, L = 30 mm)	44	4.5	32	S
Right Engine Bracket Bolts (Cylinder Head Side)	10	1.0	89 in·lb	L
Right Front Engine Mounting Bolt (M10, L = 67 mm)	44	4.5	32	S
Crankshaft/Transmission				
Bearing Position Plate Screws	5.0	0.51	44 in·lb	L
Breather Plate Bolts	10	1.0	89 in·lb	L
Connecting Rod Bid End Bolts	see Text	←	←	MO
Coolant Drain Plug (Cylinder)	10	1.0	89 in·lb	
Crankcase Bolts (M9)	39	4.0	29	MO, S
Crankcase Bolts (M8)	27	2.8	20	S
Crankcase Bolts (M7, L = 85 mm)	20	2.0	15	S
Crankcase Bolts (M7, L = 50 mm)	20	2.0	15	S
Crankcase Bolts (M7, L = 32 mm)	20	2.0	15	S
Crankcase Bolts (M8, L = 45 mm)	12	1.2	106 in·lb	S

Torque and Locking Agent

Fastener	Torque			Remarks
	N·m	kgf·m	ft·lb	
Crankcase Bolts (M6, L = 40 mm)	12	1.2	106 in·lb	S
Drive Shaft Cover Bolts	25	2.5	18	
Gear Position Lever Bolt	12	1.2	106 in·lb	
Oil Passage Plugs	20	2.0	15	L
Piston Oil Jet	3.0	0.31	27 in·lb	
Plate Screw	5.0	0.51	44	L
Plug	20	2.0	15	
Shift Drum Bearing Holder Screws	5.0	0.51	44 in·lb	L
Shift Drum Cam Holder Bolt	12	1.2	106 in·lb	L
Shift Fork Hold Bolt	12	1.2	106 in·lb	L
Shift Lever Bolt	7.0	0.71	62 in·lb	
Shift Pedal Mounting Bolt	25	2.5	18	
Shift Shaft Return Spring Pin	29	3.0	21	L
Tie-Rod Locknuts	7.0	0.71	62 in·lb	
Wheels/Tires				
Front Axle Clamp Bolts	20	2.0	15	AL
Front Axle Nut	127	13.0	94	
Rear Axle Nut	108	11.0	80	
Final Drive				
Engine Sprocket Cover Bolts	10	1.0	89 in·lb	
Engine Sprocket Nut	125	12.7	92	MO
Rear Axle Nut	108	11.0	80	
Rear Sprocket Nuts	59	6.0	44	
Brakes				
Brake Hose Banjo Bolts	25	2.5	18	
Brake Lever Pivot Bolt	1.0	0.10	9 in·lb	Si
Brake Lever Pivot Bolt Nut	5.9	0.60	52 in·lb	
Brake Pedal Bolt	8.8	0.90	78 in·lb	
Bleed Valves	7.8	0.80	69 in·lb	
Front Brake Disc Mounting Bolts	27	2.8	20	L
Front Brake Light Switch Screw	1.2	0.12	11 in·lb	
Front Brake Master Cylinder Bleed Valve	5.4	0.55	48 in·lb	
Front Brake Pad Pins	15	1.5	11	
Front Brake Reservoir Cap Stopper Screw	1.2	0.12	11 in·lb	
Front Caliper Assembly Bolts	22	2.2	16	
Front Caliper Mounting Bolts	34	3.5	25	
Front Master Cylinder Clamp Bolts	8.8	0.90	78 in·lb	S
Rear Brake Disc Mounting Bolts	27	2.8	20	L
Rear Caliper Mounting Bolts	25	2.5	18	
Rear Master Cylinder Mounting Bolts	25	2.5	18	
Rear Master Cylinder Push Rod Locknut	17	1.7	13	
Suspension				
Front Axle Clamp Bolts	20	2.0	15	AL

Torque and Locking Agent

Fastener	Torque			Remarks
	N·m	kgf·m	ft·lb	
Front Fork Bottom Allen Bolts	23	2.3	17	L
Front Fork Clamp Bolts (Lower)	30	3.1	22	AL
Front Fork Clamp Bolts (Upper)	20	2.0	15	
Front Fork Top Plugs	23	2.3	17	
Piston Rod Nuts	15	1.5	11	
Rear Shock Absorber Bracket Nut	59	6.0	44	
Rear Shock Absorber Nut (Lower)	34	3.5	25	
Rear Shock Absorber Nut (Upper)	34	3.5	25	
Swingarm Pivot Adjusting Shaft	20	2.0	15	
Swingarm Pivot Shaft Nut	108	11.0	80	
Swingarm Pivot Adjusting Collar Locknut	98	10.0	72	
Tie-Rod Nuts	59	6.0	44	
Uni-Trak Rocker Arm Nut	34	3.5	25	
Steering				
Front Fork Clamp Bolts (Lower)	30	3.1	22	AL
Front Fork Clamp Bolts (Upper)	20	2.0	15	
Handlebar Bolts	25	2.5	18	
Handlebar Position Bolts	9.8	1.0	87 in·lb	L
Steering Stem Nut	20	2.0	15	
Steering Stem Head Nut	78	8.0	58	
Steering Stem Locknut	–	–	–	Hand-tighten
Switch Housing Screws	3.5	0.36	31 in·lb	
Frame				
Front Fender Mounting Bolts	3.9	0.40	35 in·lb	
Front Footpeg Bracket Bolts	25	2.5	18	
Rear Master Cylinder Mounting Bolts	25	2.5	18	
Rear Frame Bolts	44	4.5	32	
Sidestand Bolt	44	4.5	32	G
Sidestand Bracket Bolts	49	5.0	36	L
Sidestand Switch Bolt	8.8	0.90	78 in·lb	L
Rear Footpeg Bracket Bolts	25	2.5	18	
Windshield Mounting Bolts	0.4	0.04	4 in·lb	
Electrical System				
Alternator Cover Bolts	10	1.0	89 in·lb	
Alternator Lead Holding Plate Bolt	10	1.0	89 in·lb	L
Alternator Rotor Bolt	155	15.8	114	
Battery Cable Mounting Bolt	4.0	0.41	35 in·lb	
Camshaft Position Sensor Bolt	10	1.0	89 in·lb	
Crankshaft Sensor Bolts	6.0	0.61	53 in·lb	L
Frame Earth Mounting Bolt	10	1.0	89 in·lb	
Front Turn Signal Light Mounting Screws	1.2	0.12	10 in·lb	
Front Brake Light Switch Screw	1.2	0.12	10 in·lb	
Fuel Pump Bolts	10	1.0	89 in·lb	

Torque and Locking Agent

Fastener	Torque			Remarks
	N·m	kgf·m	ft·lb	
Gear Position Switch Screws	3.0	0.31	27 in·lb	L
Headlight Mounting Screws	1.2	0.12	11 in·lb	
Idle Gear Cover Bolts	10	1.0	89 in·lb	
Left Handlebar Switch Housing Screws (M5, L = 25)	3.5	0.36	31 in·lb	
License Plate Light Cover Screws	1.2	0.12	11 in·lb	
License Plate Light Mounting Screws	1.2	0.12	11 in·lb	
Meter Unit Mounting Screws	1.2	0.12	11 in·lb	
Oil Pressure Switch	15	1.5	11	SS
Oil Pressure Switch Terminal Bolt	1.5	0.15	13 in·lb	G
Oxygen Sensors (Europe Models)	25	2.5	18	
Rear Turn Signal Light Lens Screws	1.2	0.12	11 in·lb	
Rear Turn Signal Light Mounting Screws	1.2	0.12	11 in·lb	
Regulator/Rectifier Bolts	10	1.0	89 in·lb	
Right Handlebar Switch Housing Screws (M5, L = 45)	3.5	0.36	31 in·lb	
Sidestand Switch Bolts	8.8	0.90	78 in·lb	L
Spark Plugs	13	1.3	115 in·lb	
Speed Sensor Bolt	10	1.0	89 in·lb	
Starter Clutch Bolt	49	5.0	36	
Starter Clutch Bolt Cap	–	–	–	Hand-tighten
Starter Clutch Cover Bolts (M6, L = 30)	10	1.0	89 in·lb	
Starter Clutch Cover Bolts (M6, L = 20)	10	1.0	89 in·lb	
Starter Motor Cable Mounting Bolt	4.0	0.41	35 in·lb	
Starter Motor Cable Terminal Nut	6.0	0.61	53 in·lb	
Starter Motor Mounting Bolts	10	1.0	89 in·lb	
Starter Motor Terminal Locknut	6.9	0.70	61 in·lb	
Starter Motor Through Bolts	3.4	0.35	30 in·lb	
Stator Coil Bolts	12	1.2	106 in·lb	
Vehicle-down Sensor Bolts	6.0	0.61	53 in·lb	
Water Temperature Sensor	25	2.5	18	SS

Torque and Locking Agent

The table below, relating tightening torque to thread diameter, lists the basic torque for the bolts and nuts. Use this table for only the bolts and nuts which do not require a specific torque value. All of the values are for use with dry solvent-cleaned threads.

Basic Torque for General Fasteners

Threads Diameter (mm)	Torque		
	N·m	kgf·m	ft·lb
5	3.4 ~ 4.9	0.35 ~ 0.50	30 ~ 43 in·lb
6	5.9 ~ 7.8	0.60 ~ 0.80	52 ~ 69 in·lb
8	14 ~ 19	1.4 ~ 1.9	10 ~ 13.5
10	25 ~ 34	2.6 ~ 3.5	19 ~ 25
12	44 ~ 61	4.5 ~ 6.2	33 ~ 45
14	73 ~ 98	7.4 ~ 10.0	54 ~ 72
16	115 ~ 155	11.5 ~ 16.0	83 ~ 115
18	165 ~ 225	17.0 ~ 23.0	125 ~ 165
20	225 ~ 325	23.0 ~ 33.0	165 ~ 240

www.zxforums.com

Specifications

Item	Standard	Service Limit
Fuel System (DFI)		
Throttle Grip Free Play	2 ~ 3 mm (0.08 ~ 0.12 in.)	---
Idle Speed	1 100 ±50 r/min (rpm)	---
Throttle Body Vacuum	31.5 ±1.3 kPa (236 ±10 mmHg) at idle speed	---
Air Cleaner Element	Viscous paper element	---
Cooling System		
Coolant:		
Type (Recommended)	Permanent type antifreeze	---
Color	Green	---
Mixed Ratio	Soft water 50%, coolant 50%	---
Freezing Point	-35°C (-31°F)	---
Total Amount	2.9 L (3.1 US qt)	---
Engine Top End		
Valve Clearance:		
Exhaust	0.17 ~ 0.22 mm (0.0067 ~ 0.0087 in.)	---
Inlet	0.15 ~ 0.24 mm (0.0059 ~ 0.0094 in.)	---
Clutch		
Clutch Lever Free Play	2 ~ 3 mm (0.08 ~ 0.12 in.)	---
Engine Lubrication System		
Engine Oil:		
Type	API SE, SF or SG API SH, SJ or SL with JASO MA	---
Viscosity	SAE 10W-40	---
Capacity	3.2 L (3.4 US qt) (when filter is not removed)	---
	3.7 L (3.9 US qt) (when filter is removed)	---
	4.0 L (4.2 US qt) (when engine is completely dry)	---
Level	Between upper and lower level lines (Wait 2 ~ 3 minutes after idling or running)	---
Wheels/Tires		
Tread Depth:		
Front	6.0 mm (0.24 in.)	1 mm (0.04 in.), (AT, CH, DE) 1.6 mm (0.06 in.)
Rear	6.5 mm (0.26 in.)	Up to 130 km/h (80 mph): 2 mm (0.08 in.), Over 130 km/h (80 mph): 3 mm (0.12 in.)
Air Pressure (when Cold):		
Front	Up to 180 kg (397 lb) load: 250 kPa (2.50 kgf/cm ² , 36 psi)	---
Rear	Up to 180 kg (397 lb) load: 290 kPa (2.90 kgf/cm ² , 42 psi)	---
www.zxforums.com	www.zxforums.com	www.zxforums.com

2-14 PERIODIC MAINTENANCE

www.zxforums.com

www.zxforums.com

www.zxforums.com

Specifications

Item	Standard	Service Limit
Final Drive		
Drive Chain Slack	30 ~ 35 mm (1.2 ~ 1.4 in.)	---
Drive Chain Wear (20-link Length)	317.5 ~ 318.2 mm (12.50 ~ 12.53 in.)	323 mm (12.7 in.)
Standard Chain:		
Make	RK EXCEL	---
Type	RK 525MFO, Endless	---
Link	108 links	---
Brakes		
Brake Fluid:		
Grade	DOT4	---
Brake Pad Lining Thickness:		
Front	4.0 mm (0.16 in.)	1 mm (0.04 in.)
Rear	5.0 mm (0.20 in.)	1 mm (0.04 in.)
Brake Light Timing:		
Front	Pulled ON	---
Rear	On after about 10 mm (0.39 in.) of pedal travel	---
Electrical System		
Spark Plug		
Type	NGK CR9EIA-9	---

Special Tools

Inside Circlip Pliers:
57001-143

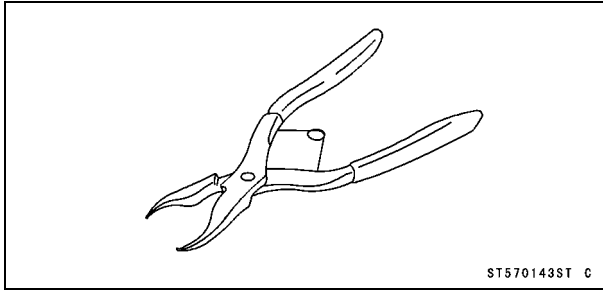

Vacuum Gauge:
57001-1369

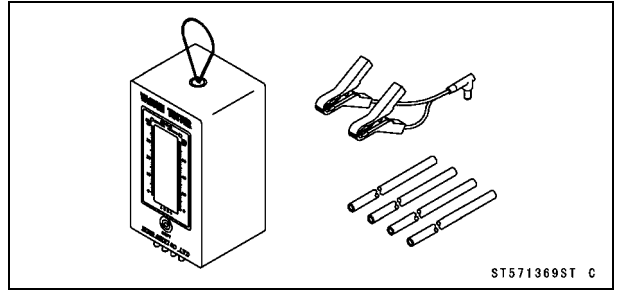

Steering Stem Nut Wrench:
57001-1100

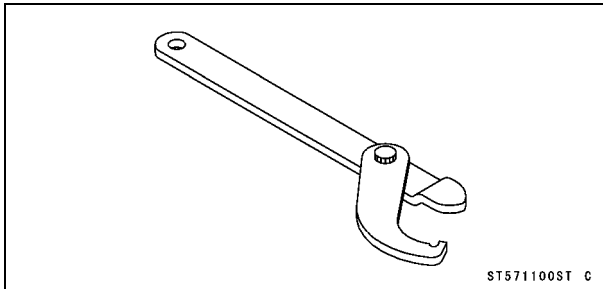

Extension Tube:
57001-1578

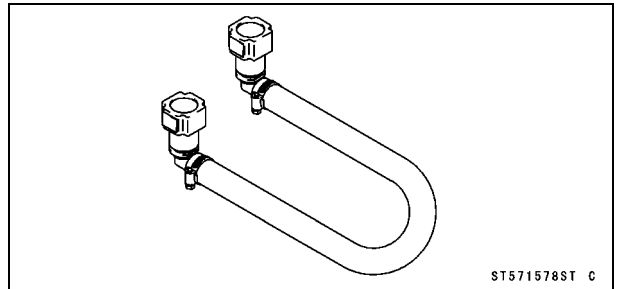

Jack:
57001-1238

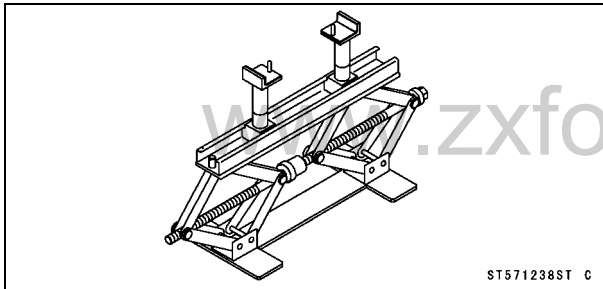

Pilot Screw Adjuster, D:
57001-1588

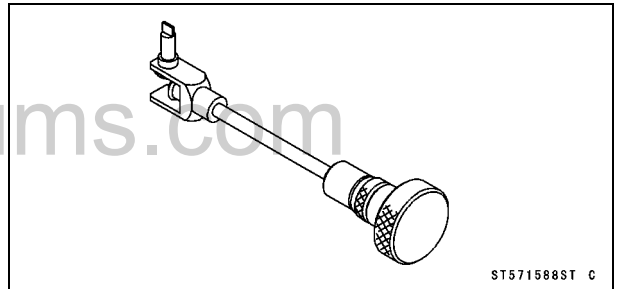

Oil Filter Wrench:
57001-1249

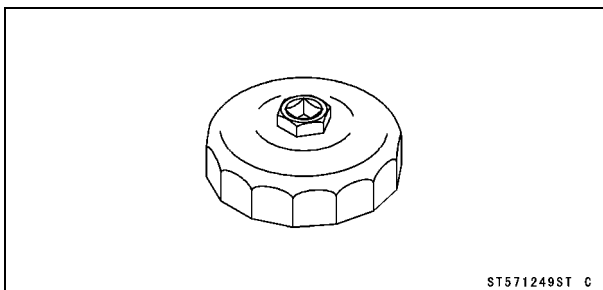

Jack Attachment:
57001-1608

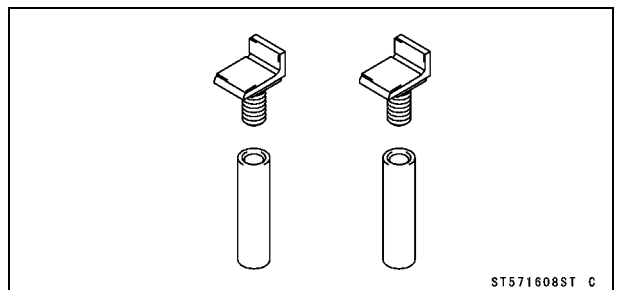

Maintenance Procedure

Fuel System (DFI)

Throttle Control System Inspection

- Check the throttle grip free play [A].
- ★ If the free play is incorrect, adjust the throttle cables.

Throttle Grip Free Play

Standard: 2 ~ 3 mm (0.08 ~ 0.12 in.)

- Check that the throttle grip [B] moves smoothly from full open to close, and the throttle closes quickly and completely by the return spring in all steering positions.
- ★ If the throttle grip does not return properly, check the throttle cables routing, grip free play, and cable damage. Then lubricate the throttle cable.
- Run the engine at the idle speed, and turn the handlebar all the way to the right and left to ensure that the idle speed does not change.
- ★ If the idle speed increases, check the throttle cable free play and the cable routing.
- ★ If necessary, adjust the throttle cable as follows.
 - Loosen the locknuts [A] [B].
 - Screw both throttle cable adjusters [C] [D] to give the throttle grip plenty of play.
 - Turn the decelerator cable adjuster [C] until 2 ~ 3 mm (0.08 ~ 0.12 in.) of throttle grip play is obtained.
 - Tighten the locknut [A].
 - Turn the accelerator cable adjuster [D] until 2 ~ 3 mm (0.08 ~ 0.12 in.) of throttle grip play is obtained.
 - Tighten the locknut [B].
- ★ If the free play cannot be adjusted with the adjusters, replace the cable.

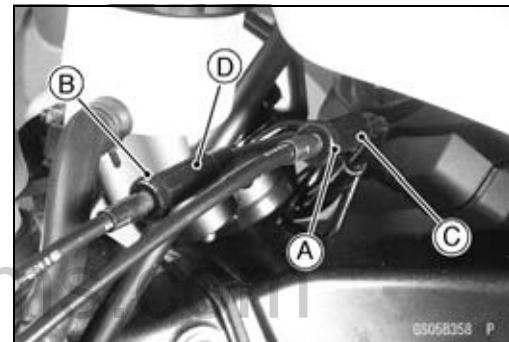
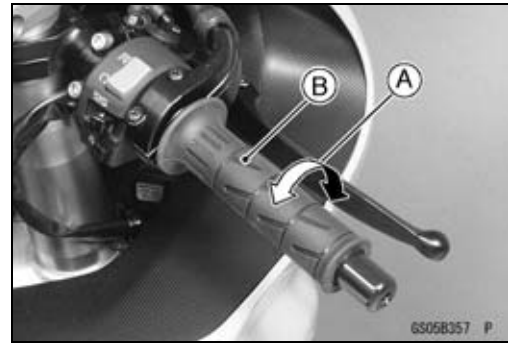

Engine Vacuum Synchronization Inspection

NOTE

○ These procedures are explained on the assumption that the inlet and exhaust systems of the engine are in good condition.

- Situate the motorcycle so that it is vertical.
- Remove the air cleaner housing (see Air Cleaner Housing Removal in the Fuel System (DFI) chapter).
- Pull off the rubber caps [A] from the fittings of each throttle body.
- For the California Model, pull off the vacuum hoses [B].
- Plug the engine breather hose end [A].

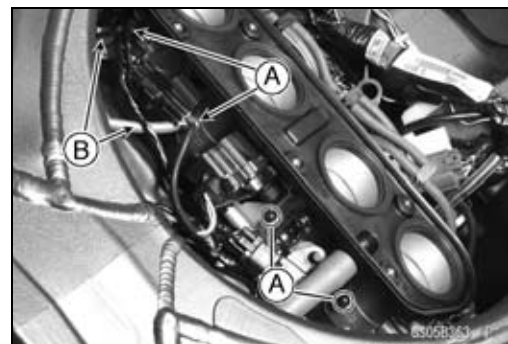

Maintenance Procedure

- Connect a vacuum gauge (special tool) and hoses [A] to the fittings on the throttle body.

Special Tool - Vacuum Gauge: 57001-1369

- Connect a highly accurate tachometer to one of the stick coil primary leads.

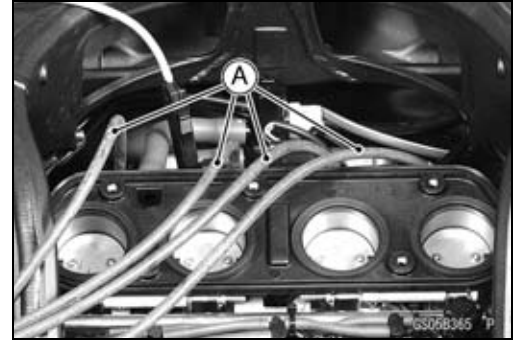

- Connect:
Fuel Pump Lead Connector
Extension Tube [A]

Special Tool - Extension Tube: 57001-1578

- Start the engine and warm it up thoroughly.
- Check the idle speed, using a highly accurate tachometer [B].
- ★ If the idle speed is out of the specified range, adjust it with the adjust screw.

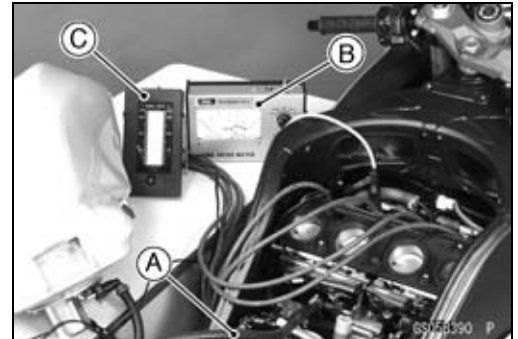

CAUTION

Do not measure the idle speed by the tachometer of the meter unit.

- While idling the engine, inspect the throttle body vacuum, using the vacuum gauge [C].

Throttle Body Vacuum

**Standard: 31.5 ±1.3 kPa (236 ±10 mmHg) at Idle Speed
1 100 ±50 r/min (rpm)**

- ★ If any vacuum is not within specifications, first synchronize the balance of the left (#1, #2 throttle valves) and right (#3, #4 throttle valves) assemblies.

Example:

- #1: 210 mmHg
- #2: 240 mmHg
- #3: 200 mmHg
- #4: 220 mmHg

- With the engine at the correct idle speed, equalize higher vacuum of #1 or #2 (for example 240 mmHg) to higher vacuum of #3 or #4 (for example 220 mmHg) by turning the center adjusting screw [A].



NOTE

○ After adjustment, the final vacuum measurement between the highest throttle valves may not be 240 mmHg (for example). The goal is to have the highest two vacuums between the left (#1 and #2) and right (#3 and #4) banks be the same and be within the service limits.

- Open and close the throttle after each measurement, and adjust the idle speed as necessary.
- Once the throttle valves have been synchronized, inspect output voltage of the main throttle sensor to ensure proper operation (procedure is explained at the end of this section).

Maintenance Procedure

★ If a value of measured vacuum pressure is out of the specified range after synchronization, adjust the bypass screws [A].

Special Tool - Pilot Screw Adjuster, D: 57001-1588

- Adjust lower vacuum between #1 and #2 to higher vacuum of #1 and #2.
- Adjust the lower vacuum between #3 and #4 to higher vacuum of #3 and #4.
- Open and close the throttle valves after each measurement, and adjust the idle speed as necessary.
- Check the vacuums as before.
- ★ If all vacuums are within the specification range, finish the engine vacuum synchronization.
- ★ If any vacuum cannot be adjusted within the specification, remove the bypass screws #1 ~ #4 and clean them.
- Turn in the bypass screw [A] with counting the number of turns until it seals fully but not tightly. Record the number of turns.

Torque - Bypass Screw: 0.2 N·m (0.02 kgf·m, 1.7 in·lb)

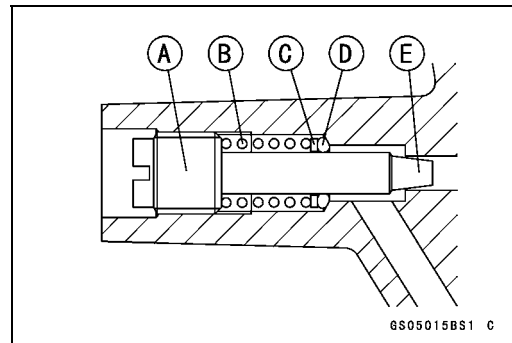
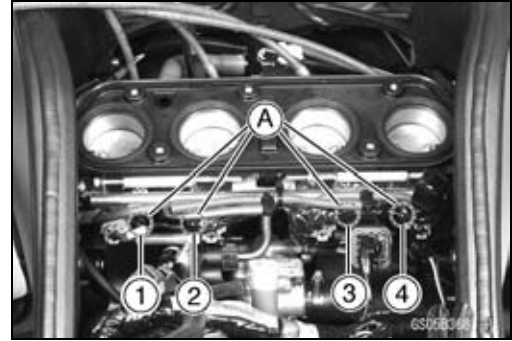

CAUTION

Do not over tighten them. They could be damaged, requiring replacement.

- Remove:
 - Bypass Screw
 - Spring [B]
 - Washer [C]
 - O-ring [D]
- Check the bypass screw and its hole for carbon deposits.
- ★ If any carbons accumulate, wipe the carbons off from the bypass screw and the hole, using a cotton pad penetrated with a high-flash point solvent.
- Replace the O-ring with a new one.
- Check the tapered portion [E] of the bypass screw for wear or damage.
- ★ If the bypass screw is worn or damaged, replace it.
- Turn in the bypass screw until it seats fully but not tightly.

Torque - Bypass Screw: 0.2 N·m (0.02 kgf·m, 1.7 in·lb)

Maintenance Procedure

- Back out the same number of turns counted when first turned in. This is to set the screw to its original position.

NOTE

○A throttle body has different “turns out” of the bypass screw for each individual unit. On setting the bypass screw, use the “turns out” determined during disassembly.

- Repeat the same procedure for other bypass screws.
- Repeat the synchronization.
- ★ If the vacuums are correct, check the output voltage of the main throttle sensor (see Output Voltage Inspection of Main Throttle Sensor in the Fuel System (DFI) chapter).

Main Throttle Sensor Output Voltage

Connections to ECU

Meter (+) → Y/W lead (terminal 26)

Meter (–) → BR/BK lead (terminal 34)

Standard: DC 0.65 ~ 0.67 V (at idle throttle opening)

- ★ If the output voltage is out of the range, check the input voltage of the main throttle sensor (see Input Voltage Inspection in the Main Throttle Sensor section in the Fuel System (DFI) chapter).
- Remove the vacuum gauge hoses and install the rubber caps on the original position.
- For the California Model, install the vacuum hoses.
- Route the vacuum hoses according to Cable, Wire, and Hose Routing section in the Appendix chapter.

Idle Speed Inspection

- Start the engine and warm it up thoroughly.
- With the engine idling, turn the handlebar to both sides [A].
- ★ If handlebar movement changes the idle speed, the throttle cables may be improperly adjusted or incorrectly routed, or damaged. Be sure to correct any of these conditions before riding (see Cable, Wire, and Hose Routing section in the Appendix chapter).

WARNING

Operation with improperly adjusted, incorrectly routed, or damaged cables could result in an unsafe riding condition.

- Check the idle speed.
- ★ If the idle speed is out of specified range, adjust it.

Idle Speed

Standard: 1 100 ±50 r/min (rpm)



Maintenance Procedure

Idle Speed Adjustment

- Start the engine and warm it up thoroughly.
- Turn the adjusting screw [A] until the idle speed is correct.
- Open and close the throttle a few times to make sure that the idle speed is within the specified range. Readjust if necessary.

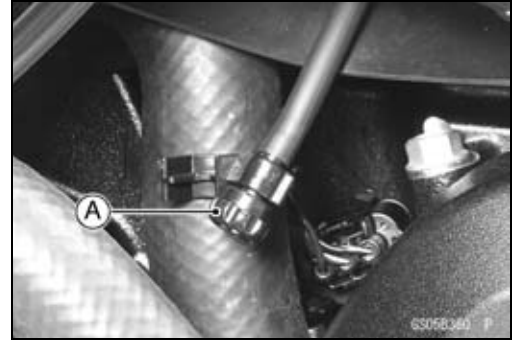

Fuel Hose Inspection (fuel leak, damage, installation condition)

○ If the motorcycle is not properly handled, the high pressure inside the fuel line can cause fuel to leak [A] or the hose to burst. Remove the fuel tank (see Fuel Tank Removal in the Fuel System (DFI) chapter) and check the fuel hose.

★ Replace the fuel hose if any fraying, cracks [B] or bulges [C] are noticed.

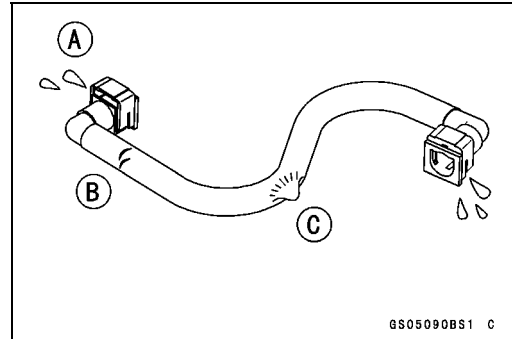

- Check that the hoses are routed according to Cable, Wire, and Hose Routing section in the Appendix chapter.

★ Replace the hose if it has been sharply bent or kinked.

- Hose Joints [A]
- Fuel Hose [B]

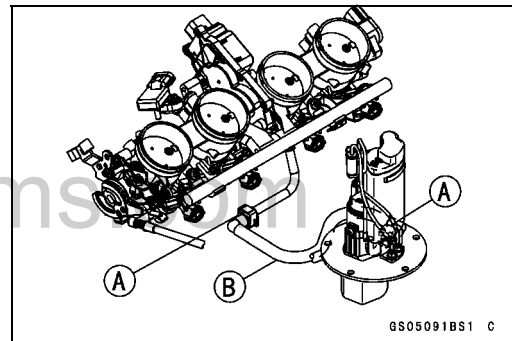

www.zxforums.com

- Check that the hose joints are securely connected.

○ Push and pull [A] the hose joint [B] back and forth more than two times, and make sure it is locked.

★ If it does not locked, reinstall the hose joint.

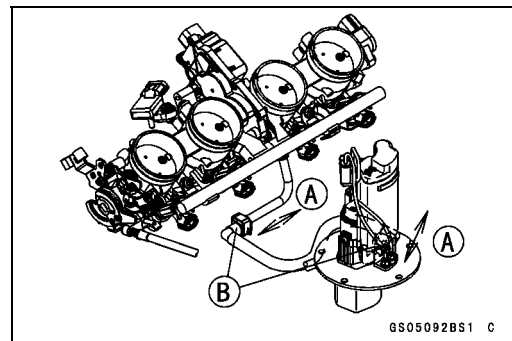

⚠ WARNING

Make sure the hose joint is installed correctly on the delivery pipe by sliding the joint, or the fuel could leak.

Maintenance Procedure

Evaporative Emission Control System (California Model)

Evaporative Emission Control System Inspection

- Inspect the canister as follows.
 - Remove the right upper inner fairing (see Upper Inner Fairing Removal in the Frame chapter).
 - Remove the canister [A], and disconnect the hoses from the canister.
 - Visually inspect the canister for cracks or other damage.
 - ★ If the canister has any cracks or bad damage, replace it with a new one.



NOTE

- *The canister is designed to work well through the motorcycle's life without any maintenance if it is used under normal conditions.*

- Check the liquid/vapor separator as follows.
 - Remove the right middle fairing (see Middle Fairing Removal in the Frame chapter).
 - Disconnect the hoses from the separator, and remove the separator [A] from the motorcycle right side.
 - Visually inspect the separator for cracks and other damage.
 - ★ If the separator has any cracks or damage, replace it with a new one.
 - To prevent the gasoline from flowing into or out of the canister, hold the separator perpendicular to the ground.
- Check the hoses of the evaporative emission control system as follows.
 - Check that the hoses are securely connected and clips are in position.
 - Replace any kinked, deteriorated or damaged hoses.
 - Route the hoses according to Cable, Wire, and Hose Routing section in the Appendix chapter.
 - When installing the hoses, avoid sharp bending, kinking, flattening or twisting, and route the hoses with a minimum of bending so that the emission flow will not be obstructed.



Maintenance Procedure

Cooling System

Coolant Level Inspection

NOTE

○ Check the level when the engine is cold (room or ambient temperature).

- Check the coolant level in the reserve tank [A] with the motorcycle held perpendicular (Do not use the sidestand).
- ★ If the coolant level is lower than the "L" level line [B], unscrew the reserve tank cap and add coolant to the "F" level line [C].

"L": low

"F": full

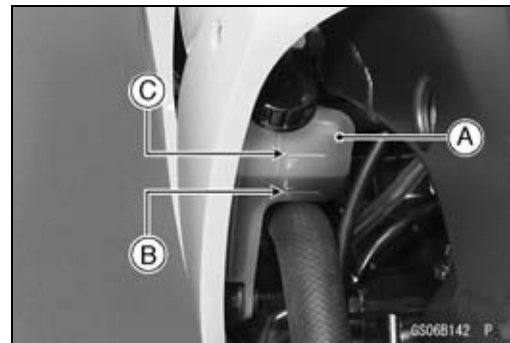

CAUTION

For refilling, add the specified mixture of coolant and soft water. Adding water alone dilutes the coolant and degrades its anticorrosion properties. The diluted coolant can attack the aluminum engine parts. In an emergency, soft water alone can be added. But the diluted coolant must be returned to the correct mixture ratio within a few days.

If coolant must be added often or the reservoir tank has run completely dry, there is probably leakage in the cooling system. Check the system for leaks.

Coolant ruins painted surfaces. Immediately wash away any coolant that spills on the frame, engine, wheels or other painted parts.

Radiator Hose and Pipe Inspection (coolant leak, damage, installation condition)

- The high pressure inside the radiator hose can cause coolant to leak [A] or the hose to burst if the line is not properly maintained. Visually inspect the hoses for signs of deterioration. Squeeze the hoses. A hose should not be hard and brittle, nor should it be soft or swollen.
- ★ Replace the hose if any fraying, cracks [B] or bulges [C] are noticed.
- Check that the hoses are securely connected and clamps are tightened correctly.

Torque - Radiator Hose Clamp Screws: 2.0 N·m (0.20 kgf·m, 18 in·lb)

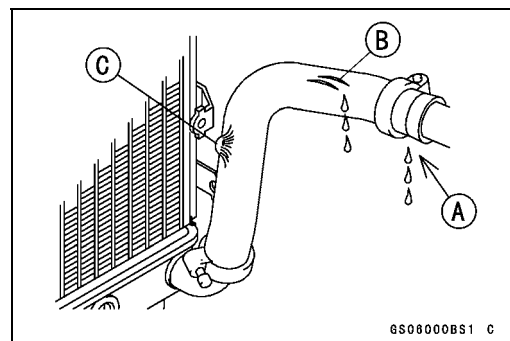

Engine Top End

Valve Clearance Inspection

NOTE

○ Valve clearance must be checked and adjusted when the engine is cold (at room temperature).

Maintenance Procedure

- Remove the cylinder head cover (see Cylinder Head Cover Removal in the Engine Top End chapter).
- Remove the timing inspection cap [A] and starter clutch bolt cap [B] on the starter clutch cover [C].

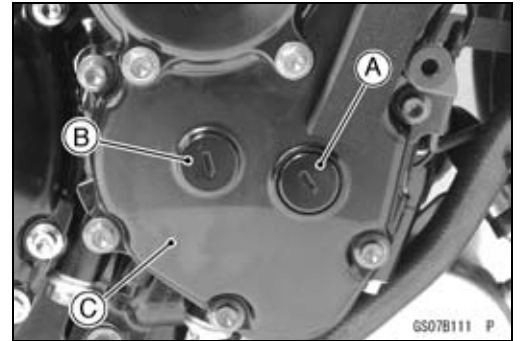

- Using a wrench on the starter clutch bolt [A], turn the crankshaft clockwise until the line [B] (TDC mark for #1,4 pistons) on the starter clutch is aligned with the notch [C] in the edge of the timing inspection hole [D] in the crankshaft sensor cover.

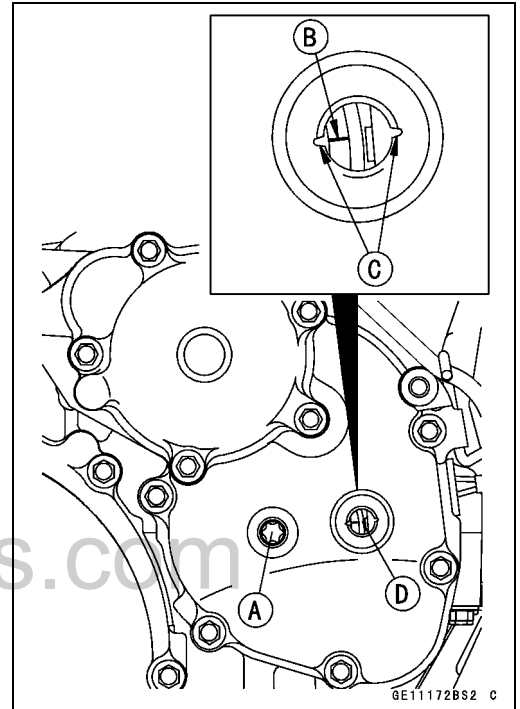

- Using a thickness gauge [A], measure the valve clearance between the cam and the valve lifter.

Valve Clearance

Standard:

Exhaust 0.17 ~ 0.22 mm (0.0067 ~ 0.0087 in.)

Inlet 0.15 ~ 0.24 mm (0.0059 ~ 0.0094 in.)

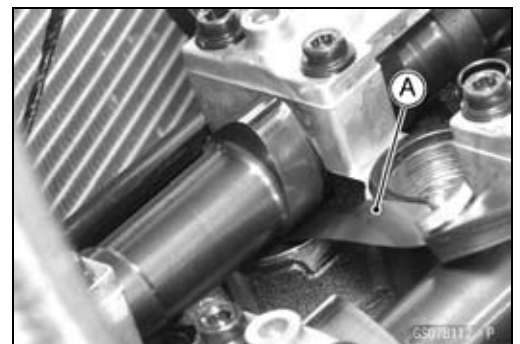

NOTE

○ Thickness gauge is horizontally inserted on the valve lifter.

Appropriateness [A]

Inadequacy [B]

Thickness Gauge [C]

Horizontally Inserts [D]

Cam [E]

Valve Lifter [F]

Hits the Valve Lifter Ahead [G]

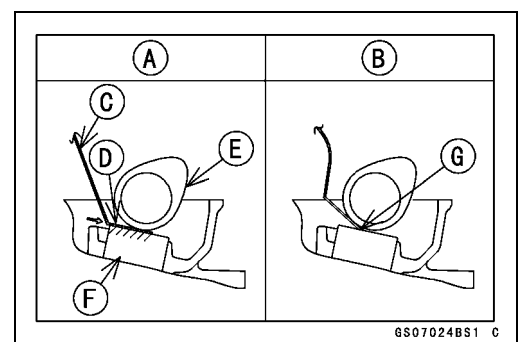

Maintenance Procedure

○When positioning #1 piston TDC at the end of the compression stroke:

- Inlet Valve Clearance of #1 and #3 Cylinders
- Exhaust Valve Clearance of #1 and #2 Cylinders
- Measuring Valve [A]

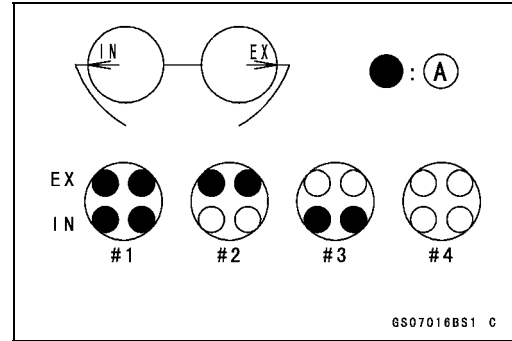

○When positioning #4 piston TDC at the end of the compression stroke:

- Inlet Valve Clearance of #2 and #4 Cylinders
- Exhaust Valve Clearance of #3 and #4 Cylinders
- Measuring Valve [A]

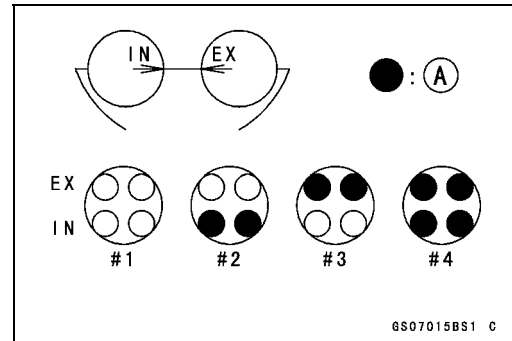

★If the valve clearance is not within the specified range, first record the clearance, and then adjust it.

Valve Clearance Adjustment

- To change the valve clearance, remove the camshaft chain tensioner, camshafts and valve lifters. Replace the shim with one of a different thickness.

NOTE

○Mark and record the locations of the valve lifters and shims so that they can be reinstalled in their original positions.

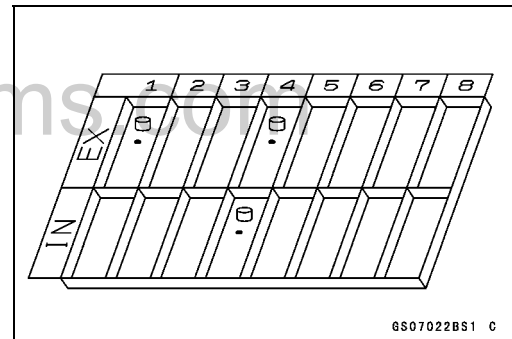

- Clean the shim to remove any dust or oil.
- Measure the thickness of the removed shim [A].
- Select a new shim thickness calculation as follows.
 - $a + b - c = d$
 - [a] Present Shim Thickness
 - [b] Measured Valve Clearance
 - [c] Specified Valve Clearance (Mean Value = 0.195)
 - [d] Replace Shim Thickness

Example:

$1.600 + 0.31 - 0.195 = 1.715 \text{ mm}$

○Exchange the shim for the 1.725 size shim.

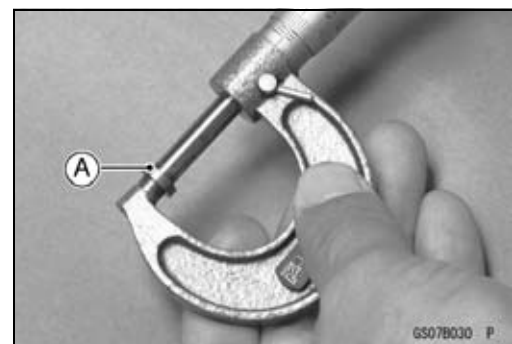

CAUTION

Don't use the shims for another models. This could cause wear of the valve stem end, and valve stem damage.

Maintenance Procedure

Adjustment Shims

Thickness	Part Number	Mark
1.300	92180-0108	130
1.325	92180-0109	132
1.350	92180-0110	135
1.375	92180-0111	138
1.400	92180-0112	140
1.425	92180-0113	142
1.450	92180-0114	145
1.475	92180-0115	148
1.500	92180-0116	150
1.525	92180-0117	152
1.550	92180-0118	155
1.575	92180-0119	158
1.600	92180-0120	160
1.625	92180-0121	162
1.650	92180-0122	165
1.675	92180-0123	168
1.700	92180-0124	170
1.725	92180-0125	172
1.750	92180-0126	175
1.775	92180-0127	178
1.800	92180-0128	180
1.825	92180-0129	182
1.850	92180-0130	185
1.875	92180-0131	188
1.900	92180-0132	190
1.925	92180-0133	192
1.950	92180-0134	195
1.975	92180-0135	198
2.000	92180-0136	200
2.025	92180-0137	202
2.050	92180-0138	205
2.075	92180-0139	208
2.100	92180-0140	210
2.125	92180-0141	212
2.150	92180-0142	215
2.175	92180-0143	218
2.200	92180-0144	220
2.225	92180-0145	222
2.250	92180-0146	225
2.275	92180-0147	228
2.300	92180-0148	230

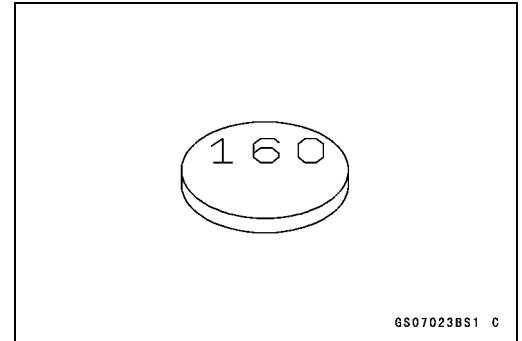

Maintenance Procedure

CAUTION

Be sure to remeasure the clearance after selecting a shim. The clearance can be out of the specified range because of the shim tolerance.

- If there is no valve clearance, use a shim that is a few sizes smaller, and remeasure the valve clearance.
- When installing the shim, face the marked side toward the valve lifter. At this time, apply engine oil to the shim or the valve lifter to keep the shim in place during camshaft installation.

CAUTION

Do not put shim stock under the shim. This may cause the shim to pop out at high rpm, causing extensive engine damage.
Do not grind the shim. This may cause it to fracture, causing extensive engine damage.

- Apply engine oil to the valve lifter surface and install the lifter.
- Install the camshafts (see Camshaft Installation in the Engine Top End chapter).
- Recheck the valve clearance and readjust if necessary.
- Install the removed parts (see appropriate chapters).

Air Suction System

Air Suction System Damage Inspection

- Remove:
 - Fuel Tank (see Fuel Tank Removal in the Fuel System (DFI) chapter)
 - Air Cleaner Housing (see Air Cleaner Housing Removal in the Fuel System (DFI) chapter)
- Pull the air switching valve hose [A] out of the air cleaner housing holder.

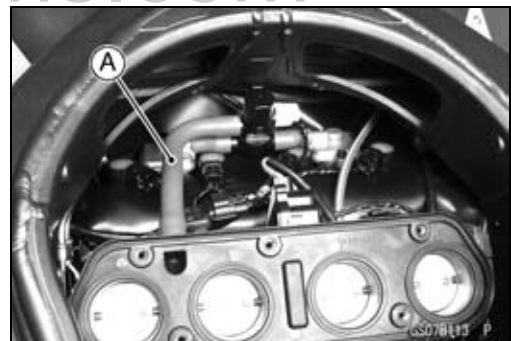

- Connect the following parts temporary.
 - Fuel Pump Lead Connector [A]
 - Extension Tube [B]

Special Tool - Extension Tube: 57001-1578

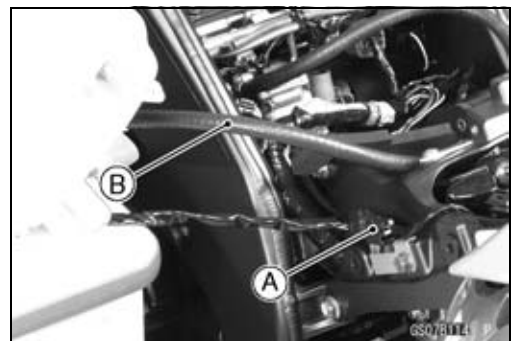

Maintenance Procedure

- Start the engine and run it at idle speed.
- Plug [A] the air switching valve hose [B] end with your finger and feel vacuum pulsing in the hose.
- ★ If there is no vacuum pulsation, check the hose line for leak. If there is no leak, check the air switching valve (see Air Switching Valve Unit Test in the Electrical System chapter) or air suction valve (see Air Suction Valve Inspection in the Engine Top End chapter).
- Apply a soap and water solution or rubber lubricant to the end of the air switching hose and install the hose on the fitting.

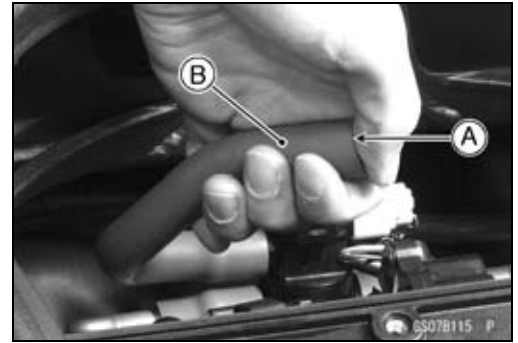

Clutch

Clutch Operation Inspection

- Pull the clutch lever just enough to take up the free play [A].
- Measure the gap between the lever and the lever holder.
- ★ If the gap is too wide, the clutch may not release fully. If the gap is too narrow, the clutch may not engage fully. In either case, adjust it.

Clutch Lever Free Play

Standard: 2 ~ 3 mm (0.08 ~ 0.12 in.)

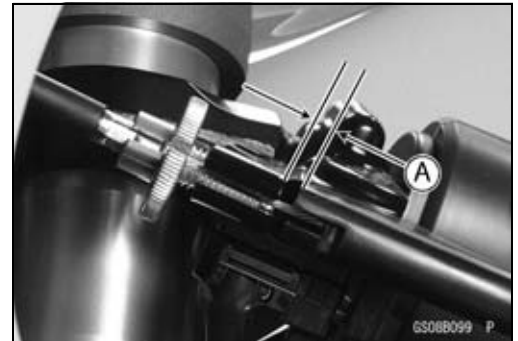

⚠ WARNING

To avoid a serious burn, never touch the engine or exhaust pipe during clutch adjustment.

- Turn the adjuster [A] so that 4 ~ 6 mm (0.16 ~ 0.24 in.) [B] of threads is visible.

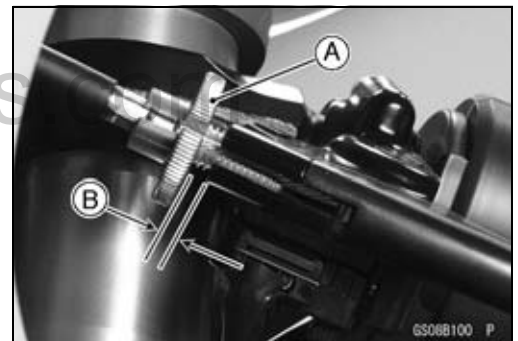

- Remove the right middle fairing [A] (see Middle Fairing Removal in the Frame chapter).
- Slide the dust cover [B] at the clutch cable lower end out of place.
- Loosen both adjusting nuts [C] at the clutch cover as far as they will go.
- Pull the clutch outer cable [D] tight and tighten the adjusting nuts against the bracket [E].
- Slip the rubber dust cover back onto place.
- Turn the adjuster at the clutch lever until the free play is correct.

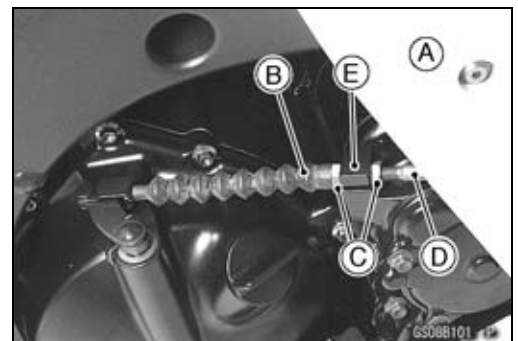

Maintenance Procedure

- Push the release lever [A] toward the front of the motorcycle until it becomes hard to turn.
- At this time, the release lever should have the proper angle shown.
60° [B]
- ★ If the angle is wrong, check the clutch and release parts for wear.

⚠ WARNING

Be sure that the outer cable end at the clutch lever is fully seated in the adjuster at the clutch lever, or it could slip into place later, creating enough cable play to prevent clutch disengagement.

- After the adjustment, start the engine and check that the clutch does not slip and that it releases properly.

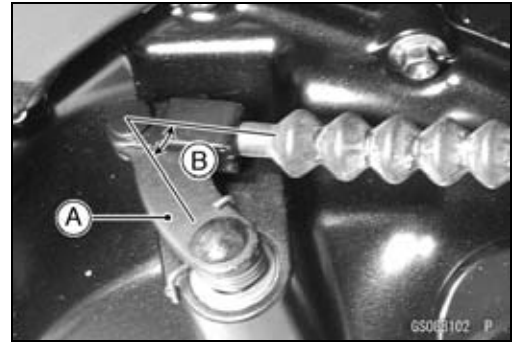

Wheels/Tires

Air Pressure Inspection

- Measure the tire air pressure with an air pressure gauge [A] when the tires are cold (that is, when the motorcycle has not been ridden more than a mile during the past 3 hours).
- Install the air valve cap.
- ★ Adjust the tire air pressure according to the specifications if necessary.

Air Pressure (when Cold)

Front: Up to 180 kg (397 lb)
250 kPa (2.50 kgf/cm², 36 psi)

Rear: Up to 180 kg (397 lb)
290 kPa (2.90 kgf/cm², 42 psi)

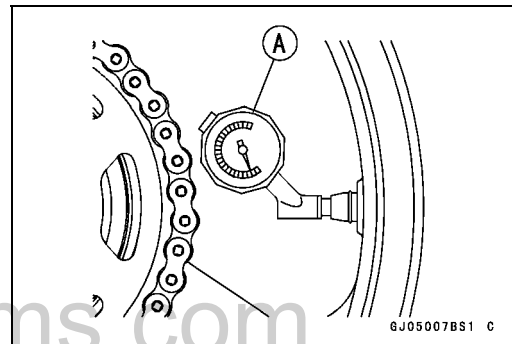

Wheel/Tire Damage Inspection

- Remove any imbedded stones [A] or other foreign particles [B] from tread.
- Visually inspect the tire for cracks and cuts, and replace the tire if necessary. Swelling or high spots indicate internal damage, requiring tire replacement.
- Visually inspect the wheel for cracks, cuts and dents damage.
- ★ If any damage is found, replace the wheel if necessary.

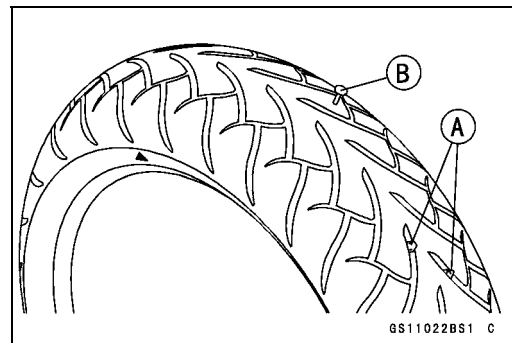

Tire Tread Wear Inspection

As the tire tread wears down, the tire becomes more susceptible to puncture and failure. An accepted estimate is that 90% of all tire failures occur during the last 10% of tread life (90% worn). So it is false economy and unsafe to use the tires until they are bald.

- Measure the tread depth at the center of the tread with a depth gauge [A]. Since the tire may wear unevenly, take measurement at several places.
- ★ If any measurement is less than the service limit, replace the tire (see Tire Removal/Installation in the Wheels/Tires chapter).

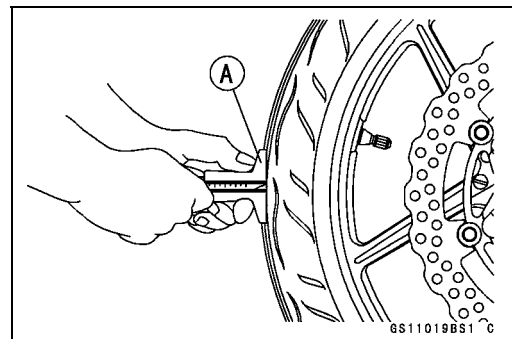

Maintenance Procedure

Tread Depth

Standard:

Front 6.0 mm (0.24 in.)

Rear 6.5 mm (0.26 in.)

Service Limit:

Front 1 mm (0.04 in.)

(AT, CH, DE) 1.6 mm (0.06 in.)

Rear 2 mm (0.08 in.) (Up to 130 km/h)

3 mm (0.12 in.) (Over 130 km/h)

⚠ WARNING

To ensure safe handling and stability, use only the recommended standard tires for replacement, inflated to the standard pressure.

NOTE

- Most countries may have their own regulations a minimum tire tread depth: be sure to follow them.
- Check and balance the wheel when a tire is replaced with a new one.

Wheel Bearing Damage Inspection

- Using a jack and attachment, raise the front wheel off the ground (see Front Wheel Removal in the Wheels/Tires chapter).
 - Turn the handlebar all the way to the right or left.
 - Inspect the roughness of the front wheel bearing by pushing and pulling [A] the wheel.
 - Spin [B] the front wheel lightly, and check for smoothly turn, roughness, binding or noise.
 - ★ If roughness, binding or noise is found, remove the front wheel and inspect the wheel bearing (see Front Wheel Removal, Hub Bearing Inspection in the Wheels/Tires chapter).
- Using a stand, raise the rear wheel off the ground (see Rear Wheel Removal in the Wheels/Tires chapter).
 - Inspect the roughness of the rear wheel bearing by pushing and pulling [A] the wheel.
 - Spin [B] the rear wheel lightly, and check for smoothly turn, roughness, binding or noise.
 - ★ If roughness, binding or noise is found, remove the rear wheel and inspect the wheel bearing (see Rear Wheel Removal, Hub Bearing Inspection in the Wheels/Tires chapter) and coupling (see Coupling Bearing Inspection in the Final Drive chapter).



Maintenance Procedure

Drive Train

Drive Chain Lubrication Condition Inspection

- If a special lubricant is not available, a heavy oil such as SAE 90 is preferred to a lighter oil because it will stay on the chain longer and provide better lubrication.
- If the chain appears especially dirty, clean it before lubrication.

CAUTION

The O-rings between the side plates seal in the lubricant between the pin and the bushing. To avoid damaging the O-rings and resultant loss of lubricant, observe the following rules.

Use only kerosene or diesel oil for cleaning of the O-ring of the drive chain.

Any other cleaning solution such as gasoline or trichloroethylene will cause deterioration and swelling of the O-ring.

Immediately blow the chain dry with compressed air after cleaning.

Complete cleaning and drying the chain within 10 minutes.

- Apply oil to the sides of the rollers so that oil will penetrate to the rollers and bushings. Apply the oil to the O-rings so that the O-rings will be coated with oil.
- Wipe off any excess oil.
 - Oil Applied Areas [A]
 - O-ring [B]

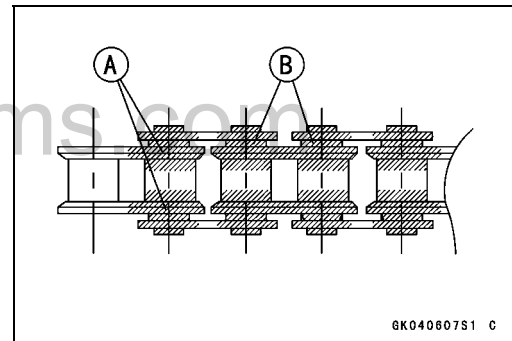

Drive Chain Slack Inspection

NOTE

- Check the slack with the motorcycle setting on its side stand.
- Clean the chain if it is dirty, and lubricate it if it appears dry.
- Check the wheel alignment (see Wheel Alignment Inspection).
- Rotate the rear wheel to find the position where the chain is tightest.
- Measure the vertical movement (chain slack) [A] midway between the sprockets.
- ★ If the chain slack exceeds the standard, adjust it.

Chain Slack

Standard: 30 ~ 35 mm (1.2 ~ 1.4 in.)

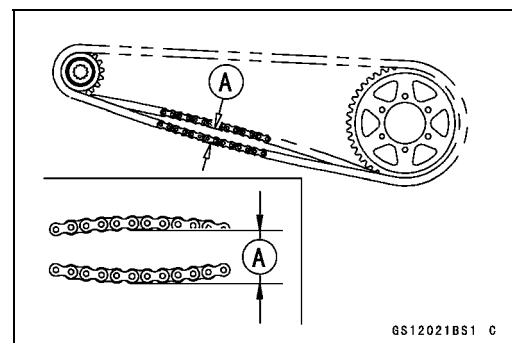

Maintenance Procedure

Drive Chain Slack Adjustment

- Remove the cotter pin [A], and loosen the rear axle nut [B].
- Loosen the both chain adjuster locknuts [C].
- ★ If the chain is too loose, turn out the left and right chain adjuster [D] evenly.
- ★ If the chain is too tight, turn in the left and right chain adjusters evenly, and kick the wheel forward.
- Turn both chain adjusters evenly until the drive chain has the correct amount of slack. To keep the chain and wheel properly aligned, the notch [E] on the left wheel alignment indicator [F] should align with the same swingarm mark or position [G] that the right indicator notch aligns with.

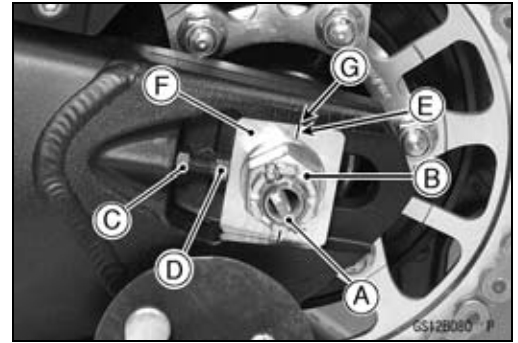

⚠ WARNING

Misalignment of the wheel will result in abnormal wear and may result in an unsafe riding condition.

- Tighten both chain adjuster locknuts securely.
- Tighten the rear axle nut.
- Torque - Rear Axle Nut: 108 N·m (11.0 kgf·m, 80 ft·lb)**
- Turn the wheel, measure the chain slack again at the tightest position, and readjust if necessary.
- Insert a new cotter pin into the axle and bend its end securely.
- Insert a new cotter pin [A].

NOTE

- When inserting the cotter pin, if the slots in the nut do not align with the cotter pin hole in the axle, tighten the nut clockwise [B] up to next alignment.
- It should be within 30 degree.
- Loosen once and tighten again when the slot goes past the nearest hole.

- Bend the cotter pin [A] over the nut.

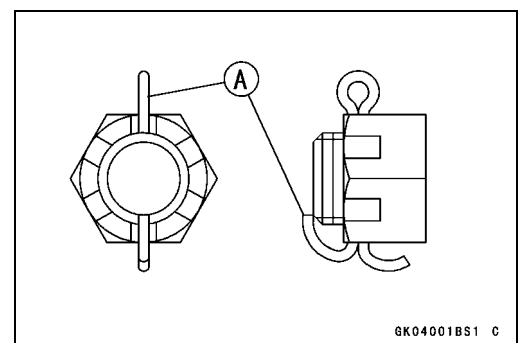
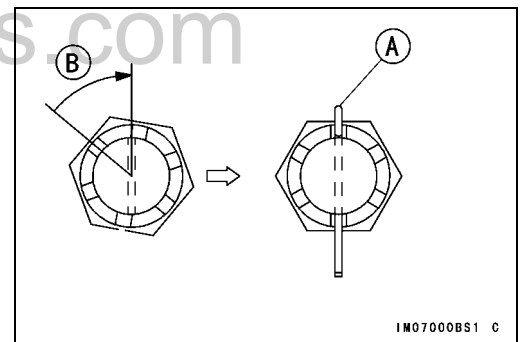

Maintenance Procedure

Wheel Alignment Inspection

- Check that the notch [A] on the left alignment indicator [B] aligns with the same swingarm mark or position [C] that the right alignment indicator notch aligns with.
- ★ If they do not, adjust the chain slack and align the wheel alignment (see Drive Chain Slack Adjustment).

NOTE

○ Wheel alignment can be also checked using the straightedge or string method.



⚠ WARNING

Misalignment of the wheel will result in abnormal wear, and may result in an unsafe riding condition.

Drive Chain Wear Inspection

- Remove:
 - Chain Cover (see Drive Chain Removal in the Final Drive chapter)
- Rotate the rear wheel to inspect the drive chain for damaged rollers, and loose pins and links.
- ★ If there is any irregularity, replace the drive chain.
- ★ Lubricate the drive chain if it appears dry.
- Stretch the chain taut by hanging a 98 N (10 kg, 20 lb) weight [A] on the chain.
- Measure the length of 20 links [B] on the straight part [C] of the chain from the pin center of the 1st pin to the pin center of the 21st pin. Since the chain may wear unevenly, take measurements at several places.
- ★ If any measurements exceed the service limit, replace the chain. Also, replace the front and rear sprockets when the drive chain is replaced.

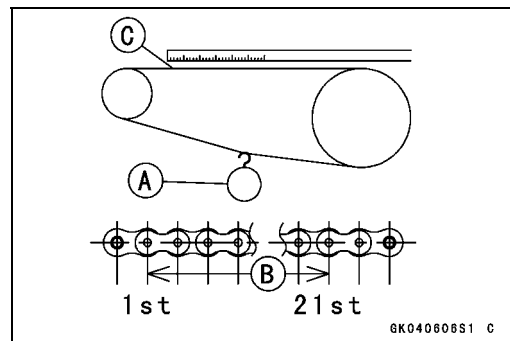

Drive Chain 20-link Length

Standard: 317.5 ~ 318.2 mm (12.50 ~ 12.53 in.)

Service Limit: 323 mm (12.7 in.)

⚠ WARNING

If the drive chain wear exceeds the service limit, replace the chain or an unsafe riding condition may result. A chain that breaks or jumps off the sprockets could snag on the engine sprocket or lock the rear wheel, severely damaging the motorcycle and causing it to go out of control.

For safety, use only the standard chain. It is an endless type and should not be cut for installation.

Standard Chain

Make: RK EXCEL

Type: RK 525MFO

Link: 108 links

Maintenance Procedure

Chain Guide Wear Inspection

- Remove:
Swingarm (see Swingarm Removal in the Suspension chapter)
- Visually inspect the chain guide [A].
- ★ Replace the chain guide if it shows any signs of abnormal wear or damage.

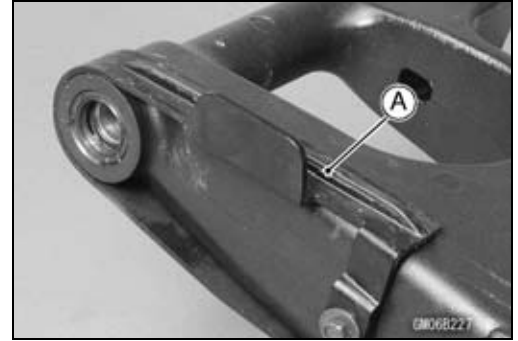

Brake System

Brake Fluid Leak (Brake Hose and Pipe) Inspection

- Apply the brake lever or pedal and inspect the brake fluid leak from the brake hoses [A] and fittings.
- ★ If the brake fluid leaked from any position, inspect or replace the problem part.

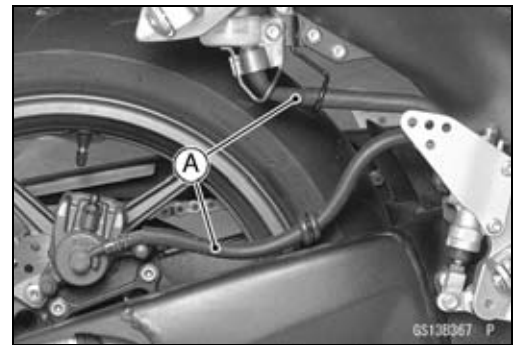

Brake Hose Damage and Installation Condition Inspection

- Inspect the brake hoses and fittings for deterioration, cracks and signs of leakage.
- The high pressure inside the brake line can cause fluid to leak [A] or the hose to burst if the line is not properly maintained. Bend and twist the rubber hose while examining it.
- ★ Replace the hose if any crack [B], bulge [C] or leakage is noticed.
- ★ Tighten any brake hose banjo bolts.

Torque - Brake Hose Banjo Bolts: 25 N·m (2.5 kgf·m, 18 ft·lb)

- Inspect the brake hose routing.
- ★ If any brake hose routing is incorrect, route the brake hose according to Cable, Wire, and Hose Routing section in the Appendix chapter.

Brake Operation Inspection

- Inspect the operation of the front and rear brake by running the vehicle on the dry road.
- ★ If the brake operation is insufficiency, inspect the brake system.

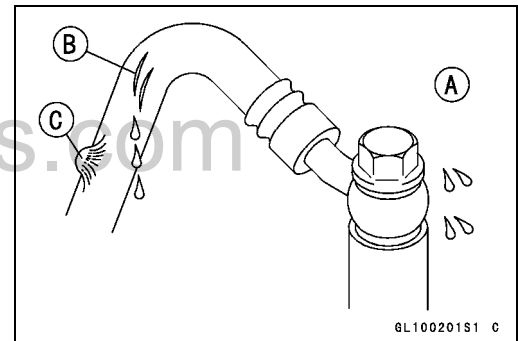

▲ WARNING

When inspecting by running the vehicle, note a surrounding traffic situation enough in the place of safety.

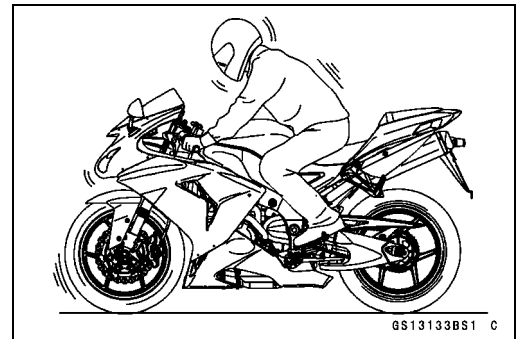

Maintenance Procedure

Brake Fluid Level Inspection

- Check that the brake fluid level in the front brake reservoir [A] is above the lower level line [B].

NOTE

○ Hold the reservoir horizontal by turning the handlebar when checking brake fluid level.

- ★ If the fluid level is lower than the lower level line, fill the reservoir to the upper level line [C].

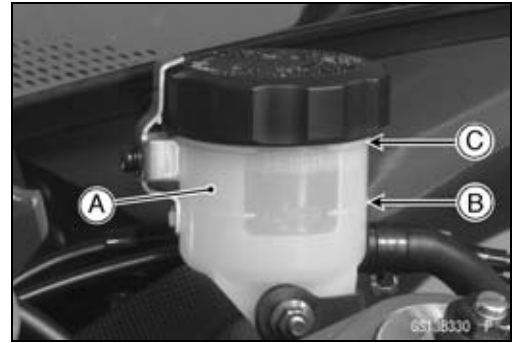

- Check that the brake fluid level in the rear brake reservoir [A] is above the lower level [B].

- ★ If the fluid level is lower than the lower level line, fill the reservoir to the upper level line [C].

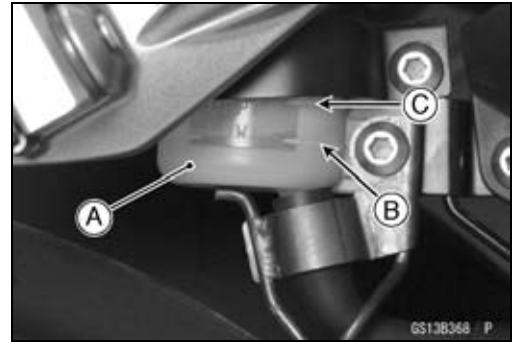

⚠ WARNING

Change the brake fluid in the brake line completely if the brake fluid must be refilled but the type and brand of the brake fluid that is already in the reservoir are unidentified. After changing the fluid, use only the same type and brand of fluid thereafter.

Recommended Disc Brake Fluid

Grade: DOT4

Brake Pad Wear Inspection

- Remove the brake pads (see Front/Rear Brake Pad Removal in the Brakes chapter).
- Check the lining thickness [A] of the pads in each caliper.
- ★ If the lining thickness of either pad is less than the service limit [B], replace both pads in the caliper as a set.

Pad Lining Thickness

Standard:

Front 4.0 mm (0.16 in.)

Rear 5.0 mm (0.20 in.)

Service Limit: 1 mm (0.04 in.)

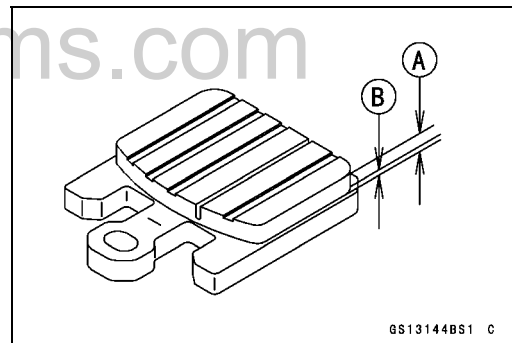

Brake Light Switch Operation Inspection

- Turn on the ignition switch.
- The brake light [A] should go on when the brake lever is applied or after the brake pedal is depressed about 10 mm (0.39 in.).



Maintenance Procedure

- ★ If it does not, adjust the brake light switch.
- While holding the switch body, turn the adjusting nut to adjust the switch.

Switch Body [A]

Adjusting Nut [B]

Light sooner as the body rises [C]

Light later as the body lowers [D]

CAUTION

To avoid damaging the electrical connections inside the switch, be sure that the switch body does not turn during adjustment.

- ★ If it does not go on, inspect or replace the following items.
 - Battery (see Charging Condition Inspection in the Electrical System chapter)
 - Brake Light (see Tail/Brake Light Removal in the Electrical System chapter)
 - Main Fuse 30 A and Taillight Fuse 10 A (see Fuse Inspection in the Electrical System chapter)
 - Front Brake Light Switch [A] (see Switch Inspection in the Electrical System chapter)
 - Rear Brake Light Switch (see Switch Inspection in the Electrical System chapter)
 - Harness (see Wiring Inspection in the Electrical System chapter)

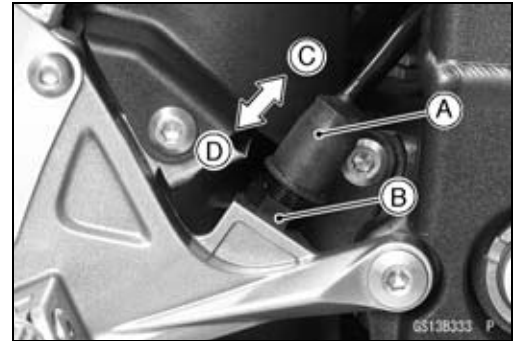

Suspensions

Front Forks/Rear Shock Absorber Operation Inspection

- Pump the forks down and up [A] 4 or 5 times, and inspect the smooth stroke.
- ★ If the forks do not smoothly or noise is found, inspect the fork oil level or fork clamps (see Front Fork Oil Change in the Suspension chapter).
- Pump the seat down and up [A] 4 or 5 times, and inspect the smooth stroke.
- ★ If the shock absorber does not smoothly stroke or noise is found, inspect the oil leak or shock absorber clamps (see Rear Shock Absorber Oil Leak Inspection in this chapter).



Maintenance Procedure

Front Fork Oil Leak Inspection

- Visually inspect the front forks [A] for oil leakage.
- ★ Replace or repair any defective parts, if necessary.



Rear Shock Absorber Oil Leak Inspection

- Visually inspect the shock absorber [A] for oil leakage.
- ★ If the oil leakage is found on it, replace the shock absorber with a new one.

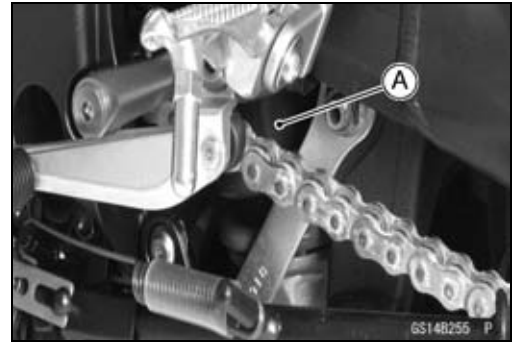

Rocker Arm Operation Inspection

- Pump the seat down and up 4 or 5 times, and inspect the smooth stroke.
- ★ If the rocker arm [A] does not smoothly stroke or noise is found, inspect the fasteners and bearings (see Rocker Arm/Tie-Rod Bearing, Sleeve Inspection in the Suspension chapter).

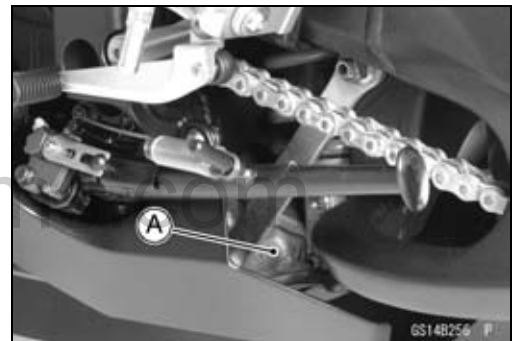

Tie-Rod Operation Inspection

- Pump the seat down and up 4 or 5 times, and inspect the smooth stroke.
- ★ If the tie-rod [A] do not smoothly stroke or noise is found, inspect the fasteners and tie-rod bearings (see Rocker Arm/Tie-Rod Bearing, Sleeve Inspection in the Suspension chapter).



Maintenance Procedure

Steering System

Steering Play Inspection

- Remove the lower fairings (see Lower Fairing Removal in the Frame chapter).
- Lift the front wheel off the ground using the jack.

Special Tools - Jack: 57001-1238

Jack Attachment: 57001-1608

- With the front wheel pointing straight ahead, alternately tap each end of the handlebar. The front wheel should swing fully left and right from the force of gravity until the fork hits the stop.
- ★ If the wheel binds or catches before the stop, the steering is too tight.
- Feel for steering looseness by pushing and pulling the forks.
- ★ If you feel looseness, the steering is too loose.

NOTE

- The cables and wiring will have some effect on the motion of the fork which must be taken into account.
- Be sure the wires and cables are properly routed.
- The bearings must be in good condition and properly lubricated in order for any test to be valid.

Steering Play Adjustment

- Remove:
 - Steering Damper (see Steering Damper Removal in the Steering chapter)
 - Stem Head Nut [A] and Washer [B]
- Loosen the upper fork clamp bolts [C] and handlebar bolts [D].
- Remove the stem head [E] with handlebar.

- Bend the claws [A] of lock washer straighten.
- Remove the steering stem locknut [B] and claw washer [C].

Special Tool - Steering Stem Nut Wrench: 57001-1100

- Adjust the steering.
- ★ If the steering is too tight, loosen the stem nut a fraction of a turn.
- ★ If the steering is too loose, tighten the stem nut a fraction of a turn.

NOTE

- Turn the stem nut 1/8 turn at time maximum.

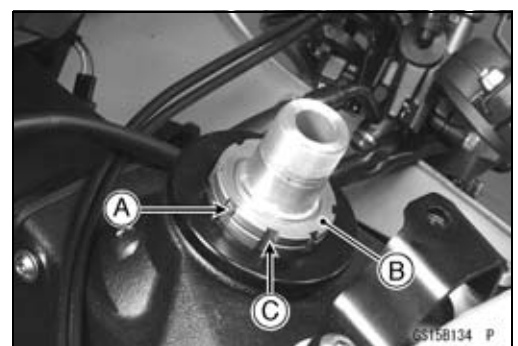
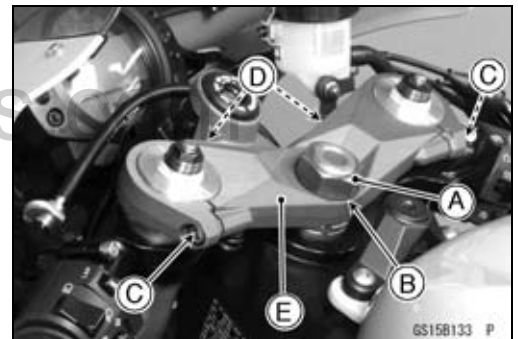
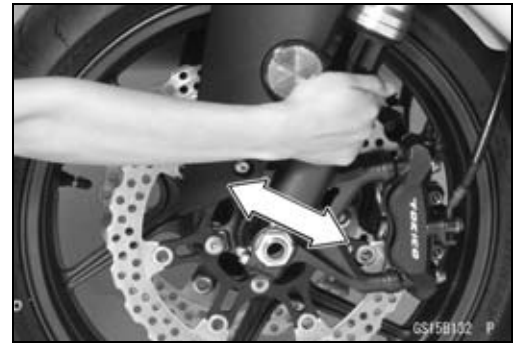

Maintenance Procedure

- Install the claw washer [A] so that its bent side [B] faces upward, and engage the bent claws with the grooves of stem locknut [C].
- Hand tighten the stem locknut until it touches the claw washer.
- Tighten the stem locknut clockwise until the claws are aligned with the grooves (ranging from 2nd to 4th) of stem nut [D], and bend the 2 claws downward [E].

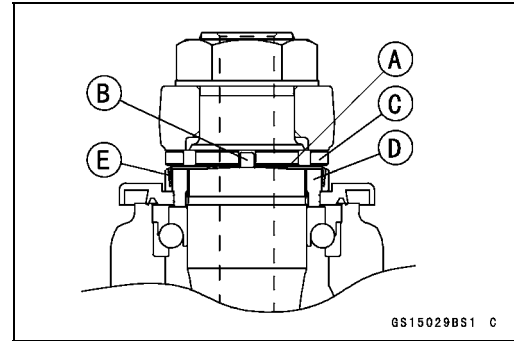

- Tighten:

Torque - Upper Front Fork Clamp Bolts: 20 N·m (2.0 kgf·m, 15 ft·lb)

Handlebar Bolts: 25 N·m (2.5 kgf·m, 18 ft·lb)

Steering Stem Head Nut: 78 N·m (8.0 kgf·m, 58 ft·lb)

- Check the steering again.
- ★ If the steering is still too tight or too loose, repeat the adjustment.

Steering Stem Bearing Lubrication

- Remove the steering stem (see Stem, Stem Bearing Removal in the Steering chapter).
- Using a high-flash point solvent, wash the upper and lower ball bearings in the cages, and wipe the upper and lower outer races, which are press-fitted into the frame head pipe, clean off grease and dirt.
- Visually check the outer races and the ball bearings.
- ★ Replace the bearing assemblies if they show wear or damage.
- Pack the upper and lower ball bearings [A] in the cages with grease, and apply a light coat of grease to the upper and lower outer races.
- Install the steering stem (see Stem, Stem Bearing Installation in the Steering chapter).
- Adjust the steering (see Steering Play Adjustment).

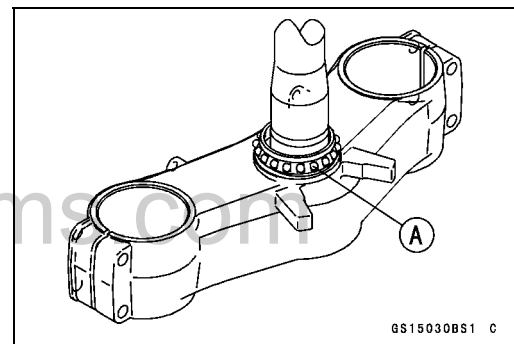

Steering Damper Oil Leak Inspection

- Visually inspect the steering damper [A] for oil leakage.
- ★ If the oil leakage is found on it, replace the steering damper with a new one.



Maintenance Procedure

Electrical System

Lights and Switches Operation Inspection

First Step

- Turn on the ignition switch.
- The following lights should go on according to below table.

City Light [A]	goes on
Taillight [B]	goes on
License Plate Light [C]	goes on
Meter Panel Illumination Light (LED) [D]	goes on
Meter Panel LCD [E]	goes on
Neutral Indicator Light (LED) [F]	goes on
Oil Pressure Warning Symbol [G] and Warning Indicator Light (LED) [H]	blinks (about 3 seconds after)

- ★ If the light does not go on, inspect or replace the following item.

Battery (see Charging Condition Inspection in the Electrical System chapter)

Applicable Bulb (see Wiring Diagram in the Electrical System chapter)

Meter Unit for Meter Panel LCD (see Electronic Combination Meter Unit Inspection in the Electrical System chapter)

Meter Unit for Neutral Indicator Light (LED) (see Electronic Combination Meter Unit Inspection in the Electrical System chapter)

Meter Unit for Warning Indicator Light (LED) (Oil Pressure Warning) (see Electronic Combination Meter Unit Inspection in the Electrical System chapter)

Meter Unit for Illumination Light (LED) (see Electric Combination Meter Unit Inspection in the Electrical System chapter)

ECU (see ECU Power Supply Inspection in the Fuel System (DFI) chapter)

Main Fuse 30 A and Taillight Fuse 10 A (see Fuse Inspection in the Electrical System chapter)

Ignition Switch (see Switch Inspection in the Electrical System chapter)

Neutral Switch (see Switch Inspection in the Electrical System chapter)

Harness (see Wiring Inspection in the Electrical System chapter)

- Turn off the ignition switch.
- The all lights should go off (for the immobilizer model, Warning Indicator Light (LED) will blinks. see Abstract in the Electrical System chapter).

- ★ If the light does not go off, replace the ignition switch.

Second Step

- Turn the ignition switch to P (Park) position.
- The city light, taillight and license plate light should go on.

- ★ If the light does not go on, inspect or replace the following item.

Ignition Switch (see Switch Inspection in the Electrical System chapter)

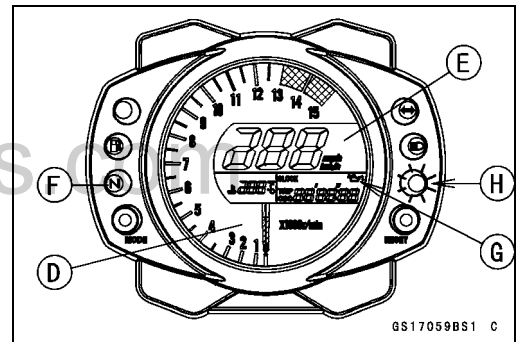
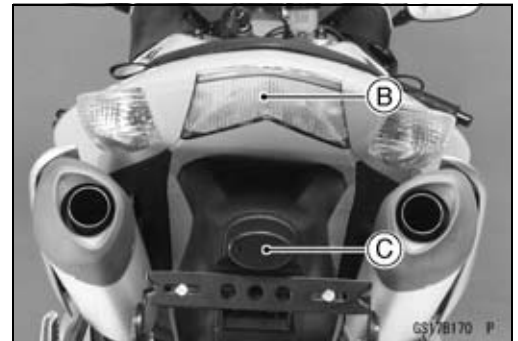

Maintenance Procedure

Third Step

- Turn on the turn signal switch [A] (left or right position).
- The left or right turn signal lights [B] (front and rear) according to the switch position should flash.
- The turn signal indicator light (LED) [C] in the meter unit should flash.

★ If the each light does not flash, inspect or replace the following item.

Turn Signal Light Bulb (see Turn Signal Light Bulb Replacement in the Electrical System chapter)

Meter Unit for Turn Signal Indicator Light (LED) (see Electronic Combination Meter Assembly Inspection in the Electrical System chapter)

Turn Signal Relay Fuse 10 A (see Fuse Inspection in the Electrical System chapter)

Turn Signal Switch (see Switch Inspection in the Electrical System chapter)

Turn Signal Relay (see Turn Signal Relay Inspection in the Electrical System chapter)

Harness (see Wiring Inspection in the Electrical System chapter)

- Push the turn signal switch.
- The turn signal lights and indicator light (LED) should go off.

★ If the light does not go off, inspect or replace the following item.

Turn Signal Switch (see Switch Inspection in the Electrical System chapter)

Turn Signal Relay (see Turn Signal Relay Inspection in the Electrical System chapter)

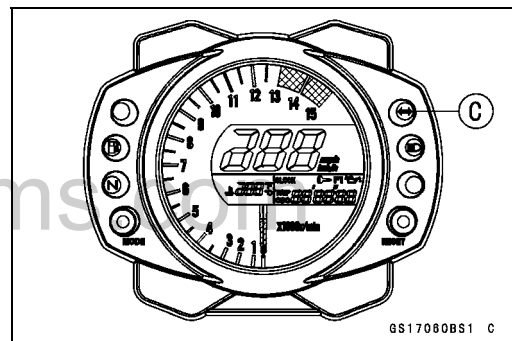

Fourth Step

- Set the dimmer switch [A] to low beam position.
 - Start the engine.
 - The low beam headlight should go on.
- ★ If the low beam headlight does not go on, inspect or replace the following item.

Headlight Low Beam Bulb (see Headlight Bulb Replacement in the Electrical System chapter)

Headlight Fuse 10 A (see Fuse Inspection in the Electrical System chapter)

Dimmer Switch (see Switch Inspection in the Electrical System chapter)

Headlight Relay in Relay Box (see Relay Circuit Inspection in the Electrical System chapter)

Harness (see Wiring Inspection in the Electrical System chapter)



Maintenance Procedure

- Set the dimmer switch to high beam position.
- The low beam [A] and high beam [B] headlights should go on.
- The high beam indicator light (LED) [C] should go on.
- ★ If the high beam headlight and/or high beam indicator light (LED) does not go on, inspect or replace the following item.
 - Headlight High Beam Bulb (see Headlight Bulb Replacement in the Electrical System chapter)
 - Dimmer Switch (see Switch Inspection in the Electrical System chapter)
- Turn off the engine stop switch.
- The low beam and high beam headlights should stay going on.
- ★ If the headlights and high beam indicator light (LED) does go off, inspect or replace the following item.
 - Headlight Relay in Relay Box (see Relay Circuit Inspection in the Electrical System chapter)
- Turn off the ignition switch.
- The headlights and high beam indicator light (LED) should go off.

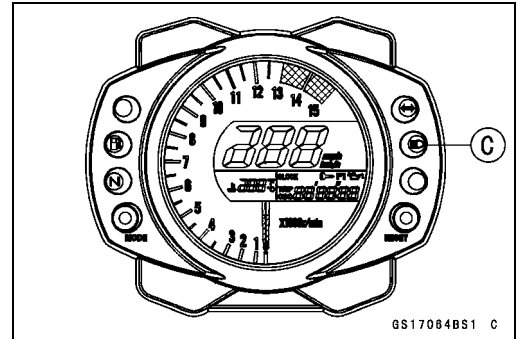
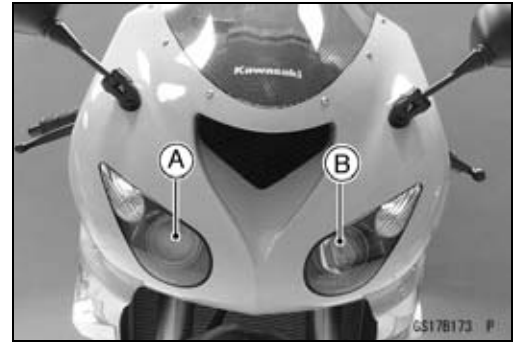

Headlight Aiming Inspection

- Inspect the headlight beam for aiming.
- ★ If the headlight beam points to one side rather than straight ahead, adjust the horizontal beam.

Headlight Beam Horizontal Adjustment

- Turn the horizontal adjuster [A] in both headlights in or out until the beam points straight ahead.
- ★ If the headlight beam points too low or high, adjust the vertical beam.

Headlight Beam Vertical Adjustment

- Turn the vertical adjuster [B] in both headlights in or out to adjust the headlight vertically.

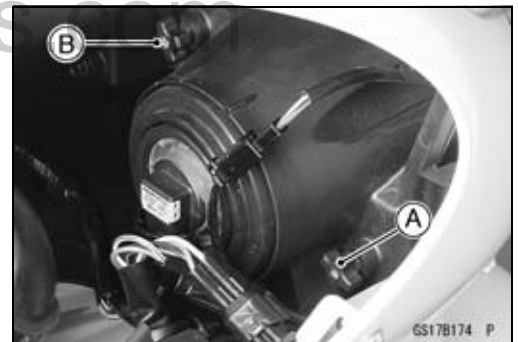

Maintenance Procedure

NOTE

- ON high beam, the brightest points should be slightly below horizontal with the motorcycle on its wheels and the rider seated. Adjust the headlight to the proper angle according to local regulations.
- For US model, the proper angle is 0.4 degrees below horizontal. This is 50 mm (2 in.) drop at 7.6 m (25 ft) measured from the center of the headlight with the motorcycle on its wheels and the rider seated.

- 50 mm (2 in.) [A]
- Center of Brightest Spot [B]
- 7.6 m (25 ft) [C]
- Low Beam [D]
- Height of Headlight Center [E]
- High Beam [F]

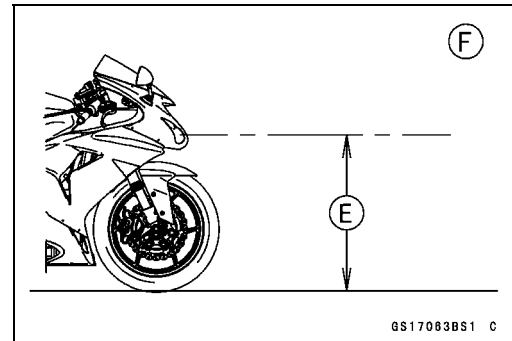
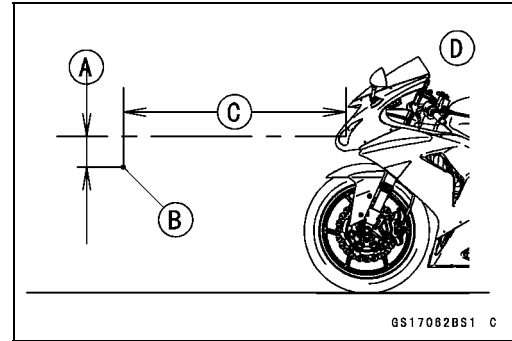

Sidestand Switch Operation Inspection

- Inspect the sidestand switch [A] operation accordance to below table.

Sidestand Switch Operation

Sidestand	Gear Position	Clutch Lever	Engine Start	Engine Run
Up	Neutral	Released	Starts	Continue running
Up	Neutral	Pulled in	Starts	Continue running
Up	In Gear	Released	Doesn't start	Continue running
Up	In Gear	Pulled in	Starts	Continue running
Down	Neutral	Released	Starts	Continue running
Down	Neutral	Pulled in	Starts	Continue running
Down	In Gear	Released	Doesn't start	Stops
Down	In Gear	Pulled in	Doesn't start	Stops



Maintenance Procedure

★ If the sidestand switch operation does not work, inspect or replace the following item.

Battery (see Charging Condition Inspection in the Electrical System chapter)

Main Fuse 30 A (see Fuse Inspection in the Electrical System chapter)

Ignition Fuse 10 A (see Fuse Inspection in the Electrical System chapter)

Ignition Switch (see Switch Inspection in the Electrical System chapter)

Sidestand Switch (see Switch Inspection in the Electrical System chapter)

Engine Stop Switch (see Switch Inspection in the Electrical System chapter)

Starter Button (see Switch Inspection in the Electrical System chapter)

Gear Position Switch (see Gear Position Switch Inspection in the Electrical System chapter)

Starter Relay (see Starter Relay Inspection in the Electrical System chapter)

Relay Box (see Relay Circuit Inspection in the Electrical System chapter)

Starter Circuit Relay (see Relay Circuit Inspection in the Electrical System chapter)

Harness (see Wiring Inspection in the Electrical System chapter)

★ If the all parts are good condition, replace the ECU.

Engine Stop Switch Operation Inspection

First Step

- Turn on the ignition switch.
- Set the neutral position.
- Turn the engine stop switch to stop position [A].
- Push the starter button.
- The engine does not start.

★ If the engine starts, inspect or replace the following item.

Engine Stop Switch (see Switch Inspection in the Electrical System chapter)

Second Step

- Turn on the ignition switch.
 - Set the neutral position.
 - Turn the engine stop switch to run position [A].
 - Push the starter button and run the engine.
 - Turn the engine stop switch to stop position.
 - Immediately the engine should be stop.
- ★ If the engine does not stop, inspect or replace the following item.

Engine Stop Switch (see Switch Inspection in the Electrical System chapter)

★ If the engine stop switch is good condition, replace the ECU (see ECU Removal/Installation in the Fuel System (DFI) chapter).



Maintenance Procedure

Others

Chassis Parts Lubrication

- Before lubricating each part, clean off any rusty spots with rust remover and wipe off any grease, oil, dirt, or grime.
- Lubricate the points listed below with indicated lubricant.

NOTE

○Whenever the vehicle has been operated under wet or rainy conditions, or especially after using a high-pressure water spray, perform the general lubrication

Pivots: Lubricate with Grease.

Brake Lever
Brake Pedal
Clutch Lever
Rear Brake Joint Pin
Sidestand

Points: Lubricate with Grease.

Clutch Inner Cable Upper and Lower Ends [A]
Throttle Inner Cable Upper and Lower Ends

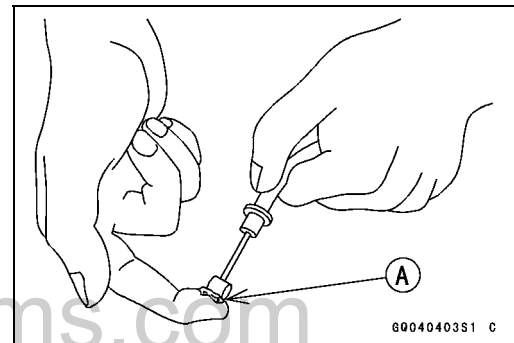

Cables: Lubricate with Rust Inhibitor

Clutch Cable
Throttle Cables

- Lubricate the cables by seeping the oil between the cable and housing.
- The cable may be lubricated by using a commercially available pressure cable lubricator with an aerosol cable lubricant.

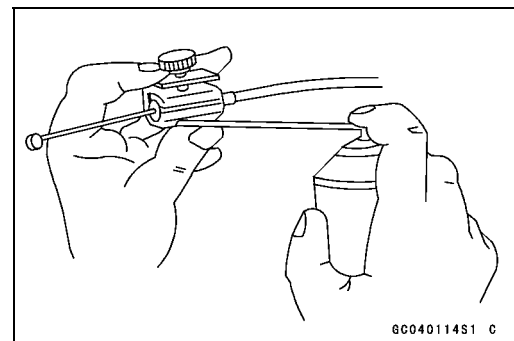

Maintenance Procedure

- With the cable disconnected at both ends, the inner cable should move freely [A] within the cable housing.
- ★ If cable movement is not free after lubricating, if the cable is frayed [B], or if the cable housing is kinked [C], replace the cable.

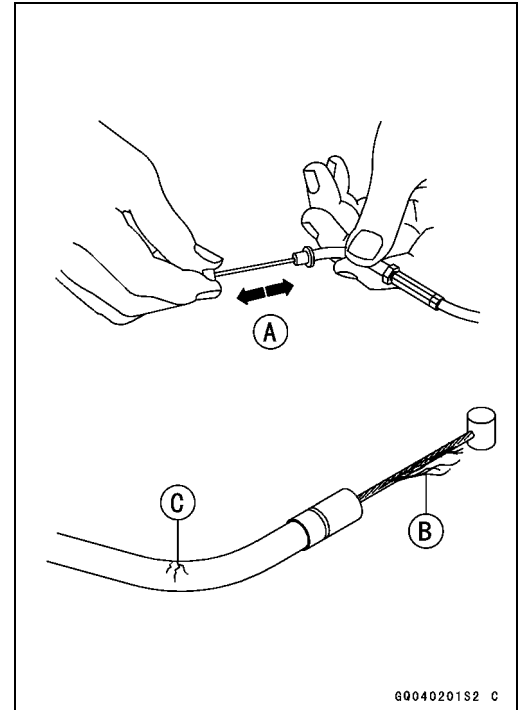

Bolts, Nuts and Fasteners Tightness Inspection

- Check the tightness of the bolts and nuts listed here. Also, check to see that each cotter pin is in place and in good condition.

NOTE

○ For the engine fasteners, check the tightness of them when the engine is cold (at room temperature).

- ★ If there are loose fasteners, retorque them to the specified torque following the specified tightening sequence. Refer to the appropriate chapter for torque specifications. If torque specifications are not in the appropriate chapter, see the Standard Torque Table. For each fastener, first loosen it by 1/2 turn, then tighten it.
- ★ If cotter pins are damaged, replace them with new ones.

Maintenance Procedure

Bolt, Nut and Fastener to be checked

Engine:

- Clutch Lever Pivot Nut
- Engine Mounting Bolts
- Exhaust Pipe Clamp Bolts
- Exhaust Pipe Manifold Holder Nuts
- Muffler Body Mounting Bolts

Wheels:

- Front Axle Clamp Bolts
- Front Axle Nut
- Rear Axle Nut
- Rear Axle Nut Cotter Pin

Brakes:

- Brake Lever Pivot Nut
- Brake Pedal Bolt
- Brake Rod Joint Cotter Pin
- Caliper Mounting Bolts
- Front Master Cylinder Clamp Bolts
- Rear Master Cylinder Mounting Bolts

Suspension:

- Front Fork Clamp Bolts
- Rear Shock Absorber Mounting Nuts
- Swingarm Pivot Shaft Nut
- Uni-Trak Link Nuts

Steering:

- Handlebar Bolts
- Steering Stem Head Nut

Others:

- Footpeg Bracket Bolts
- Front Fender Mounting Bolts
- Sidestand Bolt

Maintenance Procedure

Replacement Parts

Air Cleaner Element Replacement

NOTE

- In dusty areas, the element should be replaced more frequently than the recommended interval.
- After riding through rain or on muddy roads, the element should be replaced immediately.

⚠ WARNING

If dirt or dust is allowed to pass through into the throttle assembly, the throttle may become stuck, possibly causing an accident.

CAUTION

If dirt gets through into the engine, excessive engine wear and possibly engine damage will occur.

- Remove:
 - Fuel Tank (see Fuel Tank Removal in the Fuel System (DFI) chapter)
 - Air Cleaner Element Cover Screws [A]
 - Air Cleaner Element Cover [B]

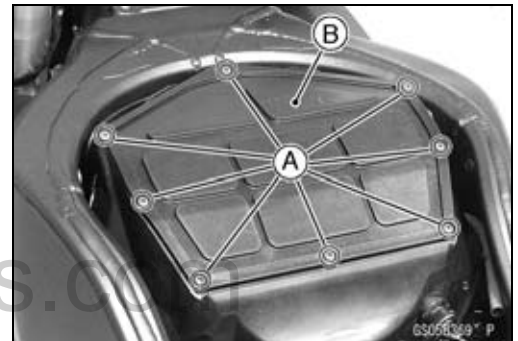

- Discard the air cleaner element [A].



Maintenance Procedure

- Install a new element [A] so that the element ends [B] insert along the rib [C] in the housing.

CAUTION

Use only the recommended air cleaner element (Kawasaki part number 11013-0004). Using another air cleaner element will wear the engine prematurely or lower the engine performance.

- Tighten:
 Torque - Air Cleaner Element Cover Screws: 1.1 N·m (0.11 kgf·m, 9.7 in·lb)

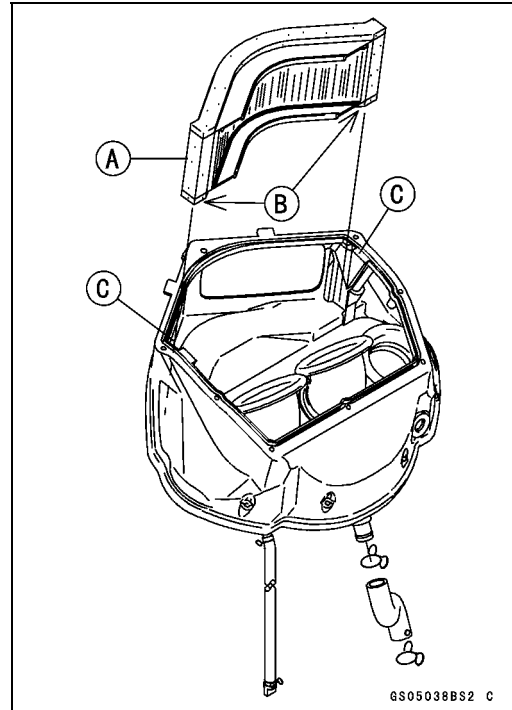

Fuel Hose Replacement

- Remove the fuel tank (see Fuel Tank Removal in the Fuel System (DFI) chapter).
- Be sure to place a piece of cloth [A] around the fuel hose joint.
- Insert a minus screw driver [B] into the slit [C] on the joint lock.

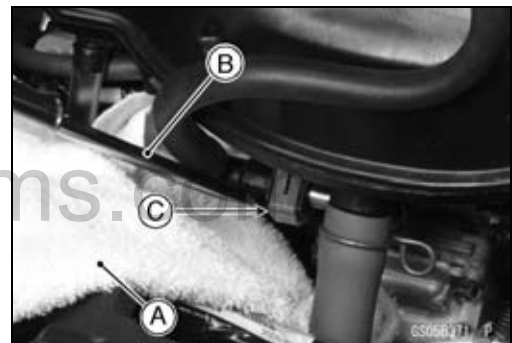

- Turn [A] the driver to disconnect the joint lock [B].
- Pull [C] the fuel hose joint [D] out of the delivery pipe.

⚠ WARNING

Be prepared for fuel spillage; any spilled fuel must be completely wiped up immediately. When the fuel hose is disconnected, fuel spills out from the hose and the pipe. Cover the hose connection with a clean shop towel to prevent fuel spillage.

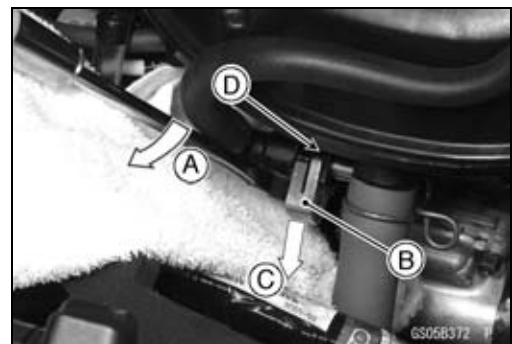

- Install the new fuel hose so that the white mark [A] side faces throttle body assy.
- Insert [B] the fuel hose joint [C] straight onto the delivery pipe until the hose joint clicks.
- Push [D] the joint lock [E].

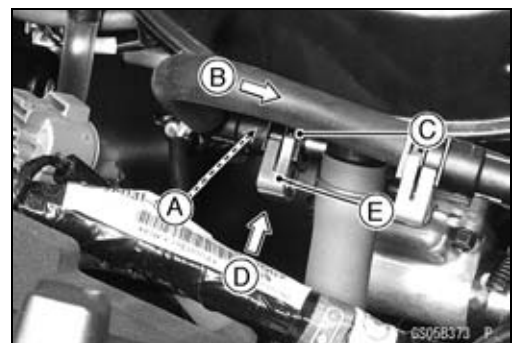

Maintenance Procedure

- Push and pull [A] the fuel hose joint [B] back and forth more than two times and make sure it is locked and doesn't come off.

⚠ WARNING

Make sure the fuel hose joint is installed correctly on the delivery pipe or the fuel could leak.

- ★ If it comes off, reinstall the hose joint.
- Run the fuel hose correctly (see Cable, Wire, and Hose Routing section in the Appendix chapter).
- Install the removed parts (see appropriate chapters).
- Start the engine and check the fuel hose for leaks.

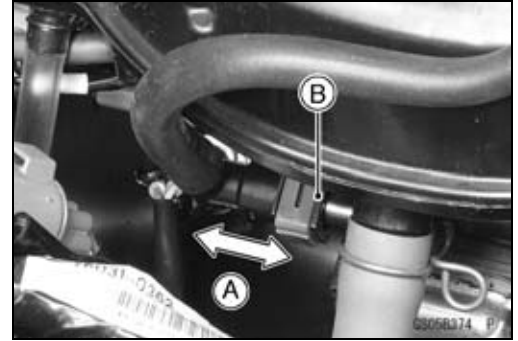

Coolant Change

⚠ WARNING

To avoid burns, do not remove the radiator cap or try to change the coolant when the engine is still hot. Wait until it cools down. Coolant on tires will make them slippery and can cause an accident and injury. Immediately wipe up or wash away any coolant that spills on the frame, engine, or other painted parts.

Since coolant is harmful to the human body, do not use for drinking.

- Remove:
 - Right Upper Inner Fairing (see Upper Inner Fairing Removal in the Frame chapter)
 - Radiator Cap [A]
- Remove the radiator cap in two steps. First turn the cap counterclockwise to the first stop. Then push and turn it further in the same direction and remove the cap.



- Remove the left middle fairing (see Middle Fairing Removal in the Frame chapter).
- Place a containers under the drain bolts [A] [B] of the water pump cover and cylinder.
- Drain the coolant from the radiator and engine by removing the drain bolts.



Maintenance Procedure

- Remove:
 - Bolts [A]
 - Coolant Reserve Tank [B]
- Remove the cap [C] and pour the coolant into a container.

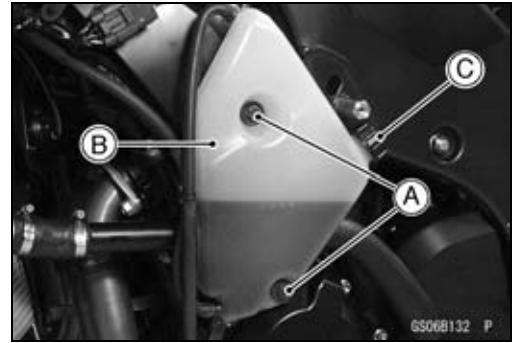

- Install the coolant reserve tank.
 - Torque - Coolant Reserve Tank Mounting Bolts: 7.0 N·m (0.71 kgf·m, 62 in·lb)**
- Tighten the drain bolts.
- ★ Replace the drain bolt gasket with a new one.
 - Torque - Coolant Drain Bolt (Water Pump): 10 N·m (1.0 kgf·m, 89 in·lb)**
 - Coolant Drain Bolt (Cylinder): 10 N·m (1.0 kgf·m, 89 in·lb)**

- Fill the radiator up to the radiator filler neck [A] with coolant, and install the radiator cap.

NOTE

○ Pour in the coolant slowly so that it can expel the air from the engine and radiator.

- Fill the reserve tank up to the full level line with coolant, and install the cap.

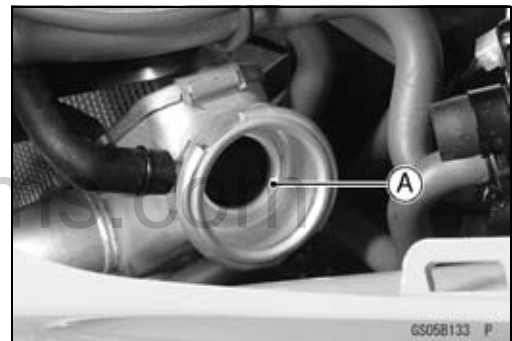

CAUTION

Soft or distilled water must be used with the antifreeze (see below for antifreeze) in the cooling system.

If hard water is used in the system, it causes scales accumulation in the water passages, and considerably reduces the efficiency of the cooling system.

Water and Coolant Mixture Ratio (Recommended)

Soft Water:	50%
Coolant:	50%
Freezing Point:	-35°C (-31°F)
Total Amount:	2.6 L (2.7 US qt)

NOTE

○ Choose a suitable mixture ratio by referring to the coolant manufacturer's directions.

Maintenance Procedure

- Bleed the air from the cooling system as follows.
- Start the engine with the radiator cap removed and run it until no more air bubbles [A] can be seen in the coolant.
- Tap the radiator hoses to force any air bubbles caught inside.
- Stop the engine and add coolant up to the radiator filler neck.
- Install the radiator cap.
- Start the engine, warm it up thoroughly until the radiator fan turns on and then stop the engine.
- Check the coolant level in the reserve tank after the engine cools down.
- ★ If the coolant level is lower than the low level line, add coolant to the full level line.

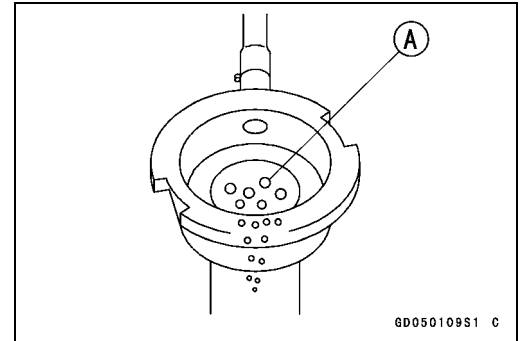

CAUTION

Do not add more coolant above the full level line.
--

www.zxforums.com

Maintenance Procedure

Radiator Hose and O-ring Replacement

- Drain the coolant (see Coolant Change).
 - Remove:
 - Lower Fairings (see Lower Fairing Removal in the Frame chapter)
 - Middle Fairings (see Middle Fairing Removal in the Frame chapter)
 - Throttle Body Assembly (see Throttle Body Assembly Removal in the Fuel System (DFI) chapter)
 - Thermostat Housing [A] (see Thermostat Housing Removal in the Cooling System chapter)
 - Oil Cooler [B] (see Oil Cooler Removal in the Engine Lubrication System chapter)
 - Water Pump [C] (see Water Pump Removal in the Cooling System chapter)
 - Fitting [D]
 - Hoses [E]
 - O-rings [F]
 - Apply grease to the new O-rings and install them.
 - Instal the new hoses and tighten the clamps securely.
- Torque - Radiator Hose Clamp Screws: 2.0 N·m (0.20 kgf·m, 18 in·lb)**
- Fill the coolant (see Coolant Change).
 - Check the cooling system for leaks.

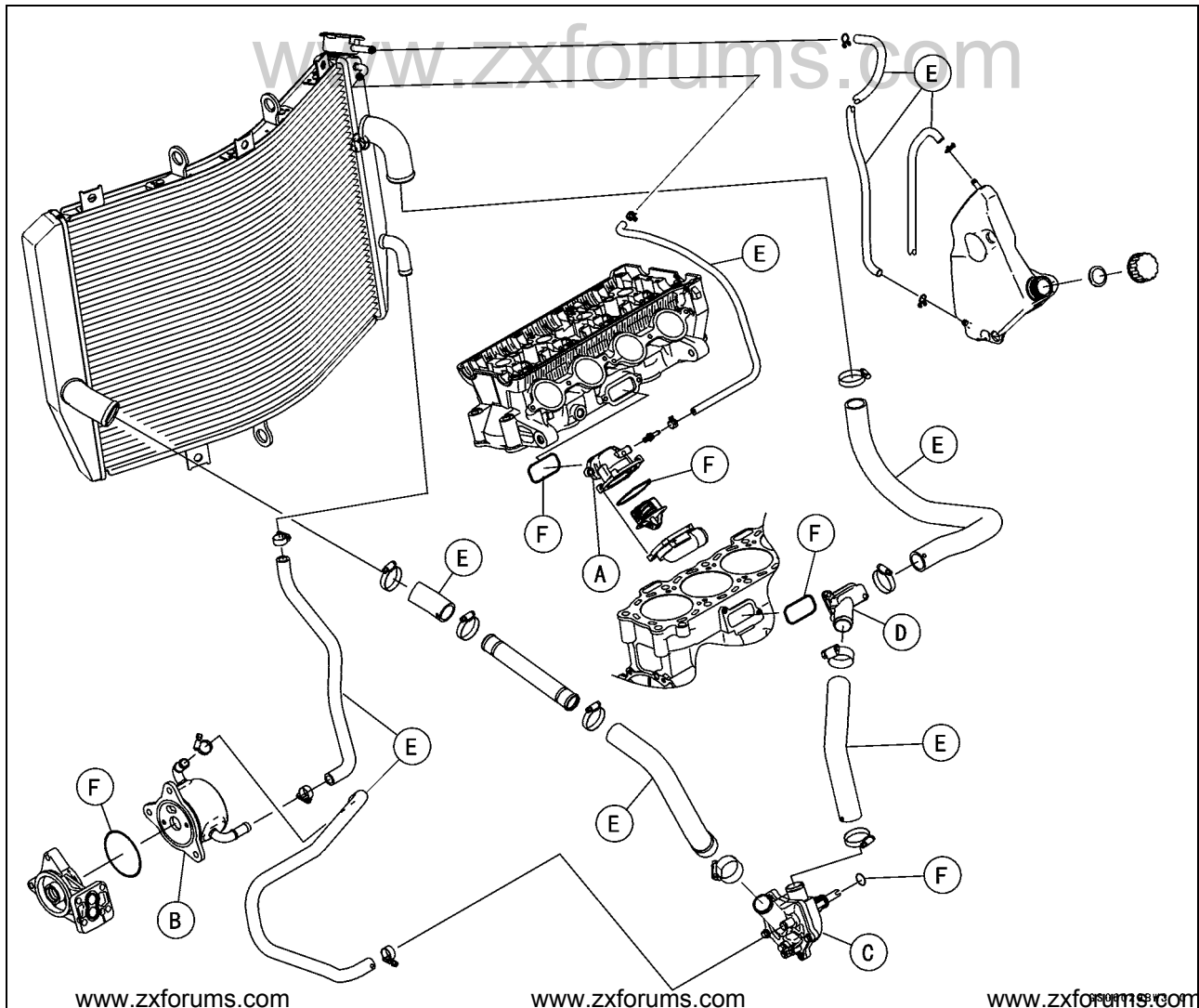

Maintenance Procedure

Engine Oil Change

- Situate the motorcycle so that it is vertical after warming up the engine.
- Remove the engine oil drain bolt [A] to drain the oil.
- The oil in the oil filter can be drained by removing the filter (see Oil Filter Replacement).
- ★ Replace the drain bolt gasket with a new one.
- Tighten the drain bolt.

Torque - Engine Oil Drain Bolt: 20 N·m (2.0 kgf·m, 15 ft·lb)

- Remove the oil filler plug [A].

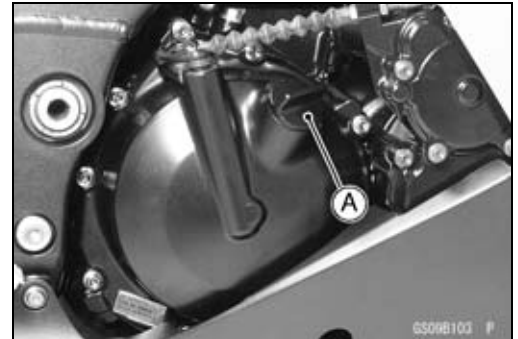

- Pour in the specified type and amount of oil.

Recommended Engine Oil

Type: API SE, SF or SG

API SH, SJ or SL with JASO MA

Viscosity: SAE 10W-40

Capacity: 3.2 L (3.4 US qt) (when filter is not removed)

3.7 L (3.9 US qt) (when filter is removed)

4.0 L (4.2 US qt) (when engine is completely dry)

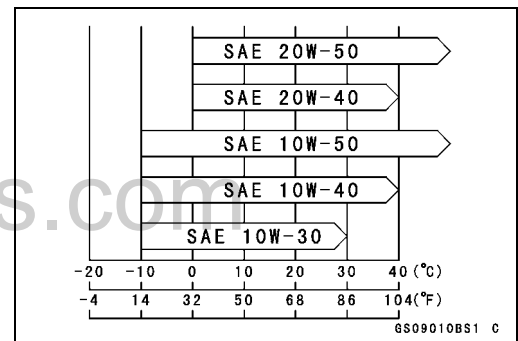

NOTE

○ Although 10W-40 engine oil is the recommended oil for most conditions, the oil viscosity may need to be changed to accommodate atmospheric conditions in your riding area.

- Replace the O-ring of the oil filler plug with a new one.
- Apply engine oil to the new O-ring.
- Install the oil filler plug.

Torque - Oil Filler Plug: Hand-tighten

Oil Filter Replacement

- Drain the engine oil (see Engine Oil Change).
- Remove the lower fairings (see Lower Fairing Removal in the Frame chapter).
- Remove the oil filter [A] with the oil filter wrench [B].

Special Tool - Oil Filter Wrench: 57001-1249

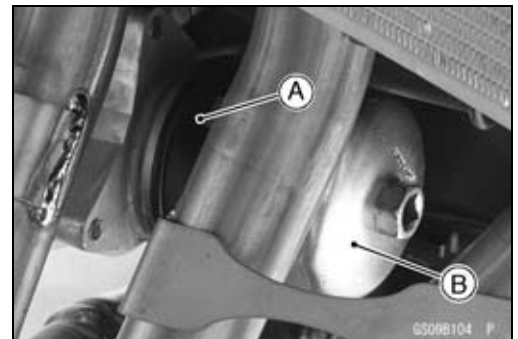

Maintenance Procedure

- Replace the filter with a new one.
- Apply engine oil to the gasket [A] before installation.
- Tighten the filter with the oil filter wrench.

Torque - Oil Filter: 31 N·m (3.2 kgf·m, 23 ft·lb)

NOTE

○Hand tightening of the oil filter can not be allowed since it does not reach to this tightening torque.

- Pour in the specified type and amount of oil (see Engine Oil Change).

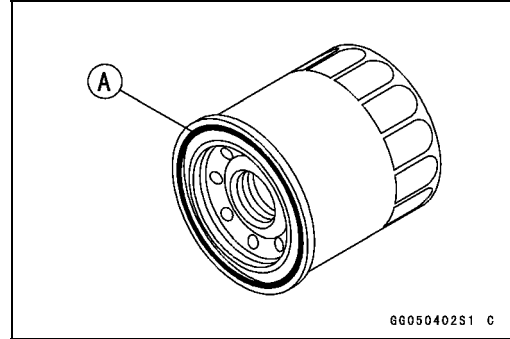

Brake Hose and Pipe Replacement

CAUTION

Brake fluid quickly ruins painted plastic surfaces; any spilled fluid should be completely washed away immediately.

- When removing the brake hose, take care not to spill the brake fluid on the painted or plastic parts.
- When removing the brake hoses [A], temporarily secure the end of the brake hose to some high place to keep fluid loss to a minimum.
- Immediately wash away any brake fluid that spills.
- There are washers on each side of the brake hose fitting. Replace them with new ones when installing.
- Tighten:

Torque - Brake Hose Banjo Bolts: 25 N·m (2.5 kgf·m, 18 ft·lb)

- When installing the hose [A], avoid sharp bending, kinking, flattening or twisting, and route the hoses according to Cable, Wire, and Hose Routing section in the Appendix chapter.
- Fill the brake line after installing the brake hose (see Brake Fluid Change).



Brake Fluid Change

NOTE

○The procedure to change the front brake fluid is as follows. Changing the rear brake fluid is the same as for the front brake.

Maintenance Procedure

- Level the brake fluid reservoir.
- Remove the reservoir cap.
- Remove the rubber cap from the bleed valve [A] on the caliper.
- Attach a clear plastic hose [B] to the bleed valve, and run the other end of the hose into a container.
- Fill the reservoir with fresh specified brake fluid.

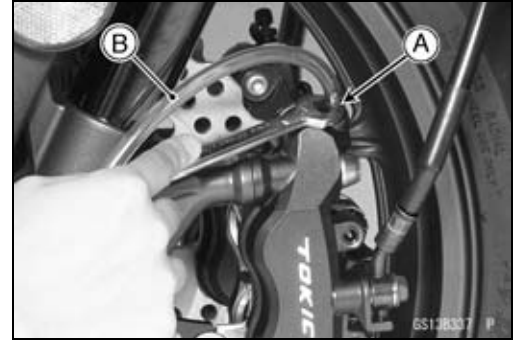

- Change the brake fluid.
 - Repeat this operation until fresh brake fluid comes out from the plastic hose or the color of the fluid changes.
 1. Open the bleed valve [A].
 2. Apply the brake and hold it [B].
 3. Close the bleed valve [C].
 4. Release the brake [D].

NOTE

- The fluid level must be checked often during the changing operation and replenished with fresh brake fluid. If the fluid in the reservoir runs out any time during the changing operation, the brakes will need to be bled since air will have entered the brake line.
- Front Brake: Repeat the above steps for the other caliper.

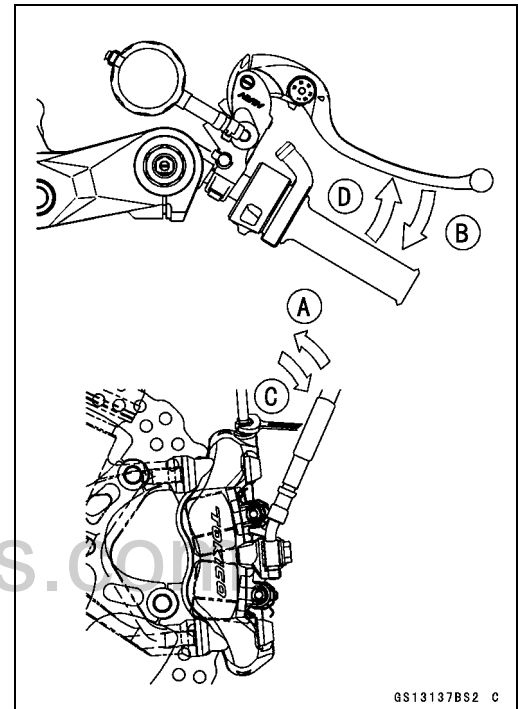

- Follow the procedure below to install the front/rear brake fluid reservoir cap correctly.
 - First, tighten the front/rear brake fluid reservoir cap [B] clockwise [C] by hand until the resistance is felt fully; then, tighten the cap an additional 1/6 turn [D] while holding the brake fluid reservoir body [A].

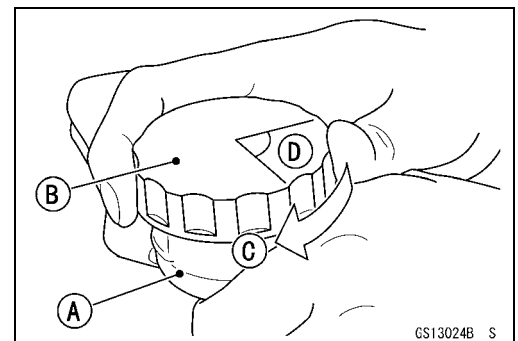

- Tighten:
 - Torque - Front Brake Reservoir Cap Stopper Screw: 1.2 N·m (0.12 kgf·m, 11 in·lb)**
- Tighten the bleed valve, and install the rubber cap.
 - Torque - Bleed Valve: 7.8 N·m (0.80 kgf·m, 69 in·lb)**
- After changing the fluid, check the brake for good braking power, no brake drag, and no fluid leakage.
- ★ If necessary, bleed the air from the lines.

Maintenance Procedure

Master Cylinder Rubber Parts Replacement

Front Master Cylinder Disassembly

- Remove the front master cylinder (see Front Master Cylinder Removal in the Brakes chapter).
- Remove the seal cover [A], circlip [B], connector [C] and O-ring [D].

Special Tool - Inside Circlip Pliers: 57001-143

- Unscrew the locknut [E] and pivot bolt [F], and remove the brake lever.
- Remove the circlip [G].
- Pull out the piston assembly [H].
- Replace:
 - Seal Cover [A]
 - Circlip [B]
 - O-ring [D]
 - Circlip [G]
 - Piston Assembly [H]
 - Diaphragm [I]

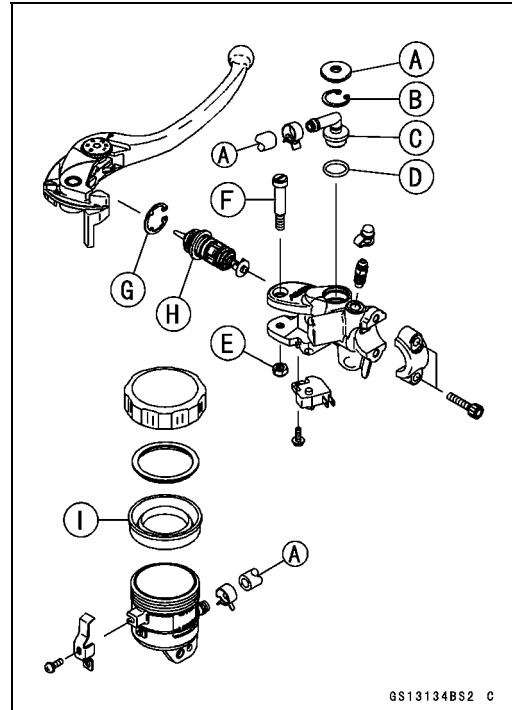

GS13134BS2 C

Rear Master Cylinder Disassembly

- Remove the rear master cylinder (see Rear Master Cylinder Removal in the Brakes chapter).
- Remove the circlip [A], connector [B] and O-ring [C].

Special Tool - Inside Circlip Pliers: 57001-143

- Slide the dust cover [D] out of place, and remove the circlip [E].
- Pull out the push rod assembly [F].

CAUTION

Do not remove the secondary cup from the piston since removal will damage it.

- Replace:
 - Circlip [A]
 - O-ring [C]
 - Circlip [E]
 - Push Rod Assembly [F]
 - Piston Assembly [G]
 - Diaphragm [H]

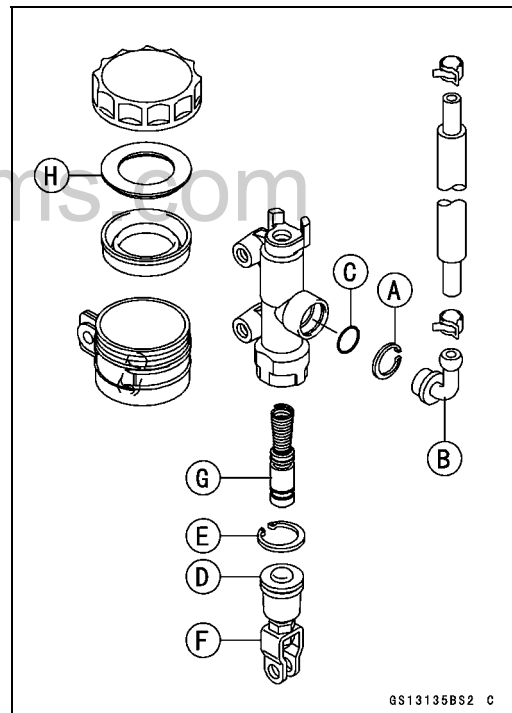

GS13135BS2 C

Master Cylinder Assembly

- Before assembly, clean all parts including the master cylinder with brake fluid or alcohol.

CAUTION

Except for the disc pads and disc, use only disc brake fluid, isopropyl alcohol, or ethyl alcohol for cleaning brake parts. Do not use any other fluid for cleaning these parts. Gasoline, engine oil, or any other petroleum distillate will cause deterioration of the rubber parts. Oil spilled on any part will be difficult to wash off completely, and will eventually deteriorate the rubber used in the disc brake.

Maintenance Procedure

- Apply brake fluid to the new parts and to the inner wall of the cylinder.
- Take care not to scratch the piston or the inner wall of the cylinder.
- Tighten the brake lever pivot bolt and the nut.

Silicone Grease - Brake Lever Pivot Bolt

Torque - Brake Lever Pivot Bolt: 1.0 N·m (0.10 kgf·m, 9 in·lb)

Brake Lever Pivot Bolt Nut: 5.9 N·m (0.60 kgf·m, 52 in·lb)

Front Brake Light Switch Screw: 1.2 N·m (0.12 kgf·m, 11 in·lb)

Caliper Rubber Parts Replacement

Front Caliper Disassembly

- Loosen the front caliper pad pins [A] and banjo bolt [B] and tighten them loosely.
- Remove:
 - Front Caliper (see Front Caliper Removal in the Brakes chapter) [C]
 - Brake Pad
 - Front Caliper Assembly Bolts
 - O-rings

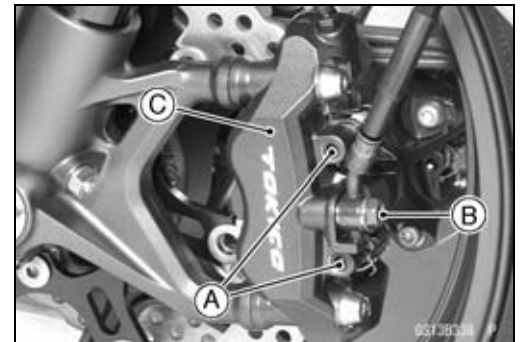

- Using compressed air, remove the pistons. One way to remove the pistons is as follows.
 - Install a rubber gasket [A] and a wooden board [B] more than 10 mm (0.4 in.) thick on the caliper half, and fasten them together with a suitable bolt and nut as shown. Leave one of the oil passages [C] open.
 - Lightly apply compressed air [D] to the oil passage until the pistons hit the rubber gasket. Block the hose joint opening [E] during this operation if the caliper half has the opening.
 - Bolt and Nut [F]
 - Oil Passage Sealed by Rubber Gasket [G]
 - Push down [H].

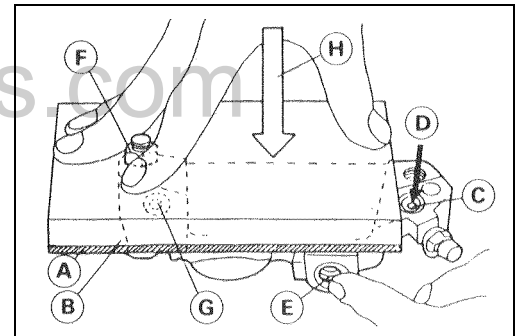

⚠ WARNING

To avoid serious injury, never place your fingers or palm in front of the piston. If you apply compressed air into the caliper, the piston may crush your hand or fingers.

- Pull out the pistons by hand.
- Remove the dust seals [A] and fluid seals [B].
- Remove the bleed valve [C] and rubber cap [D].
- Repeat the previous step to remove the pistons from the other side of the caliper body.

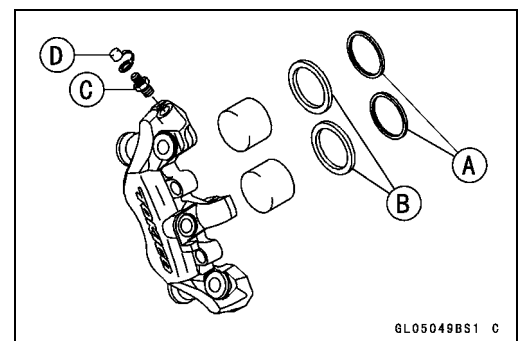

Maintenance Procedure

NOTE

- If compressed air is not available, do as follows for both calipers coincidentally, with the brake hose connected to the caliper.
- Prepare a container for brake fluid, and perform the work above it.
- Remove the pad spring and pads (see *Front Brake Pad Removal in the Brakes chapter*).
- Pump the brake lever until the pistons come out of the cylinders, and then disassemble the caliper.

Front Caliper Assembly

- Clean the caliper parts except for the pads.

CAUTION

<p>For cleaning the parts, use only disc brake fluid, isopropyl alcohol, or ethyl alcohol.</p>

- Install the bleed valve and rubber cap.
 - Torque - Bleed Valve: 7.8 N·m (0.80 kgf·m, 69 in·lb)**
- Replace the fluid seals [A] with new ones.
 - Apply brake fluid to the fluid seals, and install them into the cylinders by hand.
- Replace the dust seals [B] with new ones if they are damaged.
 - Apply brake fluid to the dust seals, and install them into the cylinders by hand.

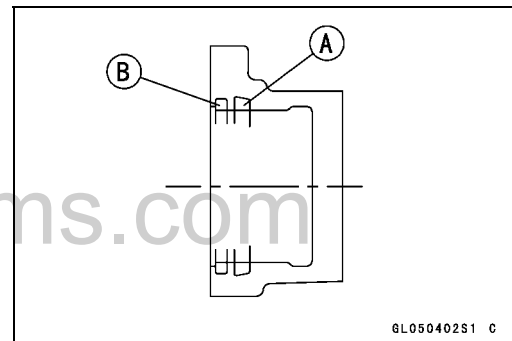

- Replace the O-ring [A].
- Apply brake fluid to the outside of the pistons, and push them into each cylinder by hand.
- Be sure to install the O-rings.
- Tighten:
 - Torque - Front Caliper Assembly Bolts: 22 N·m (2.2 kgf·m, 16 ft·lb)**

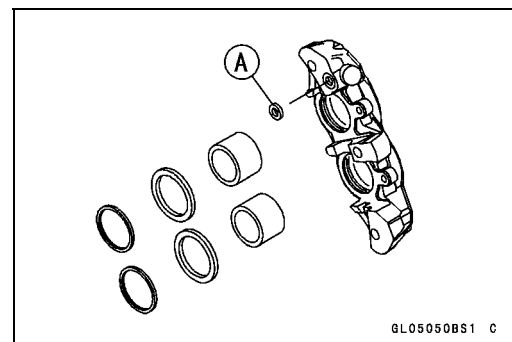

- Install the pads (see *Front Brake Pad Installation in the Brakes chapter*).
- Wipe up any spilled brake fluid on the caliper with wet cloth.

Maintenance Procedure

Rear Caliper Disassembly

- Remove the rear caliper (see Rear Caliper Removal in the Brakes chapter).
- Remove the pads and pad spring (see Rear Brake Pad Removal in the Brakes chapter).
- Using compressed air, remove the piston.
 - Cover the caliper opening with a clean, heavy cloth [A].
 - Remove the piston by lightly applying compressed air [B] to where the brake line fits into the caliper.

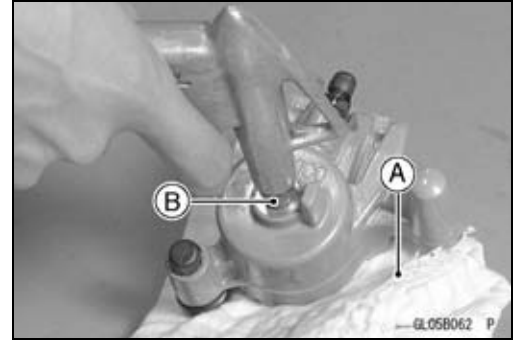

⚠ WARNING

To avoid serious injury, never place your fingers or palm inside the caliper opening. If you apply compressed air into the caliper, the piston may crush your hand or fingers.

- Remove the dust seal and fluid seal.
- Remove the bleed valve and rubber cap.

NOTE

- If compressed air is not available, do as follows with the brake hose connected to the caliper.
- Prepare a container for brake fluid, and perform the work above it.
- Remove the pads and pad spring (see Rear Brake Pad Removal in the Brakes chapter).
- Pump the brake pedal to remove the caliper piston.

Rear Caliper Assembly

- Clean the caliper parts except for the pads.

CAUTION

For cleaning of the parts, use only disc brake fluid, isopropyl alcohol, or ethyl alcohol.

- Install the bleed valve and rubber cap.

Torque - Bleed Valve: 7.8 N·m (0.80 kgf·m, 69 in·lb)

- Replace the fluid seal [A] with a new one.
 - Apply brake fluid to the fluid seal, and install it into the cylinder by hand.
- Replace the dust seal [B] with a new one.
 - Apply brake fluid to the dust seal, and install it into the cylinder by hand.

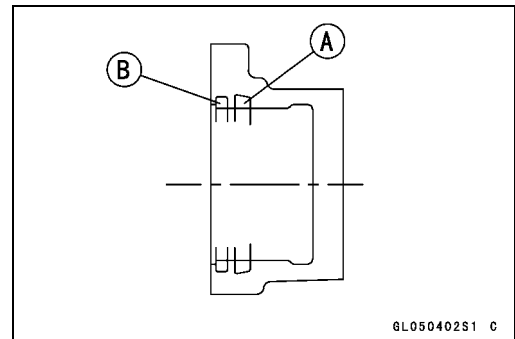

Maintenance Procedure

- Apply brake fluid to the outside of the piston, and push it into the cylinder by hand.
- Replace the shaft rubber friction boot [A] and dust boot [B].
- Apply a thin coat of PBC (Poly Butyl Cuprysil) grease to the caliper holder shafts [C] and holder holes [D] (PBC is a special high temperature, water-resistance grease).

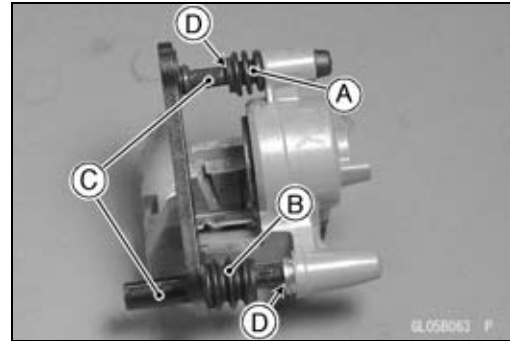

- Install the pad spring [A] in the caliper as shown.
- Install the pads (see Rear Brake Pad Installation in the Brakes chapter).
- Wipe up any spilled brake fluid on the caliper with wet cloth.

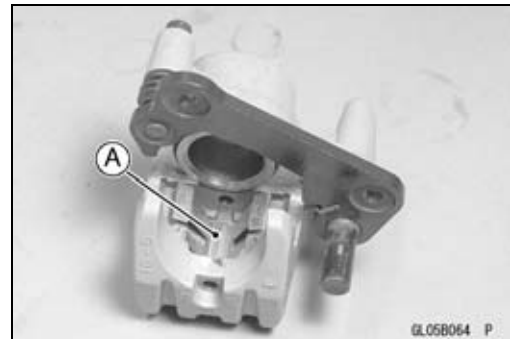

Spark Plug Replacement

- Remove:
 - Stick Coils (see Stick Coil (Ignition Coil together with Spark Plug Cap) Removal in the Electrical System chapter)
- Remove the spark plug using the 16 mm (0.63 in.) plug wrench [A] vertically.

Owner's Tool - Spark Plug Wrench, 16 mm: 92110-1132



- Replace the spark plug with a new one.

Standard Spark Plug
Type: NGK CR9EIA-9

- Insert new spark plug in the plug hole, and finger-tighten it first.
- Using the plug wrench [A] vertically, tighten the plug.

CAUTION

The insulator of the spark plug may break if when the wrench is inclined during tightening.

Torque - Spark Plugs: 13 N·m (1.3 kgf·m, 115 in·lb)

- Install the stick coils securely.
- Be sure the stick coils are installed by pulling up it lightly.



Fuel System (DFI)

Table of Contents

Exploded View.....	3-4
DFI System.....	3-10
Specifications	3-12
Special Tools and Sealant.....	3-14
DFI Parts Location.....	3-16
DFI System.....	3-18
DFI Servicing Precautions.....	3-22
DFI Servicing Precautions	3-22
Troubleshooting the DFI System.....	3-24
Outline	3-24
Inquiries to Rider.....	3-30
DFI System Troubleshooting Guide	3-33
Self-Diagnosis	3-41
Self-diagnosis Outline.....	3-41
Self-diagnosis Procedures.....	3-42
Service Code Reading.....	3-45
Service Code Erasing	3-45
Backups.....	3-47
Main Throttle Sensor (Service Code 11).....	3-50
Main Throttle Sensor Removal/Adjustment.....	3-50
Input Voltage Inspection.....	3-50
Output Voltage Inspection.....	3-52
Resistance Inspection.....	3-55
Inlet Air Pressure Sensor (Service Code 12).....	3-56
Removal.....	3-56
Installation.....	3-56
Input Voltage Inspection.....	3-56
Output Voltage Inspection.....	3-57
Inlet Air Temperature Sensor (Service Code 13).....	3-61
Removal/Installation.....	3-61
Output Voltage Inspection.....	3-61
Sensor Resistance Inspection	3-62
Water Temperature Sensor (Service Code 14)	3-64
Removal/Installation.....	3-64
Output Voltage Inspection.....	3-64
Sensor Resistance Inspection	3-65
Atmospheric Pressure Sensor (Service Code 15).....	3-66
Removal.....	3-66
Installation.....	3-66
Input Voltage Inspection.....	3-66
Output Voltage Inspection.....	3-67
Crankshaft Sensor (Service Code 21).....	3-70
Crankshaft Sensor Removal/Installation.....	3-70
Crankshaft Sensor Inspection.....	3-70
Camshaft Position Sensor (Service Code 23).....	3-71
Camshaft Position Sensor Removal/Installation.....	3-71
Camshaft Position Sensor Inspection.....	3-71
Speed Sensor (Service Code 24).....	3-72
Speed Sensor Removal/Installation.....	3-72
Input Voltage Inspection.....	3-72

Output Voltage Inspection.....	3-73
Gear Position Switch (Service Code 25).....	3-75
Gear Position Switch Removal/Installation.....	3-75
Gear Position Switch Inspection.....	3-75
Input Voltage Inspection.....	3-75
Vehicle-down Sensor (Service Code 31).....	3-77
Removal.....	3-77
Installation.....	3-77
Inspection.....	3-77
Subthrottle Sensor (Service Code 32).....	3-80
Subthrottle Sensor Removal/Adjustment.....	3-80
Input Voltage Inspection.....	3-80
Output Voltage Inspection.....	3-81
Resistance Inspection.....	3-83
Oxygen Sensor #1-not activated (Service Code 33) - Europe Models.....	3-84
Oxygen Sensor #1 Removal/Installation.....	3-84
Oxygen Sensor #1 Inspection.....	3-84
Exhaust Butterfly Valve Actuator Sensor (Service Code 34).....	3-87
Exhaust Butterfly Valve Actuator Sensor Inspection.....	3-87
Immobilizer Amplifier (Service Code 35).....	3-88
Antenna Resistance Inspection.....	3-88
Amplifier Input Voltage Inspection.....	3-88
Blank Key Detection (Service Code 36).....	3-89
User Key Inspection.....	3-89
Fuel Pump Relay (Service Code 46).....	3-90
Fuel Pump Relay Removal.....	3-90
Fuel Pump Relay Inspection.....	3-90
Stick Coils #1, #2, #3, #4: (Service Code 51, 52, 53, 54).....	3-91
Removal/Installation.....	3-91
Input Voltage Inspection.....	3-91
Subthrottle Valve Actuator (Service Code 62).....	3-93
Subthrottle Valve Actuator Removal.....	3-93
Subthrottle Valve Actuator Inspection.....	3-93
Resistance Inspection.....	3-93
Input Voltage Inspection.....	3-94
Exhaust Butterfly Valve Actuator (Service Code 63).....	3-96
Exhaust Butterfly Valve Actuator Removal.....	3-96
Exhaust Butterfly Valve Actuator Installation.....	3-96
Exhaust Butterfly Valve Actuator Inspection.....	3-97
Output Voltage Inspection.....	3-98
Oxygen Sensor Heaters (#1 and/or #2: Service Code 67) - Europe Models.....	3-99
Oxygen Sensor Heaters Removal/Installation.....	3-99
Oxygen Sensor Heaters Inspection.....	3-99
ECU Main Relay (Service Code 75).....	3-102
ECU Main Relay Inspection.....	3-102
Oxygen Sensor #2-not activated (Service Code 83) - Europe Models.....	3-103
Oxygen Sensor #2 Removal/Installation.....	3-103
Oxygen Sensor #2 Inspection.....	3-103
ECU.....	3-106
ECU Identification.....	3-106
ECU Removal.....	3-106
ECU Installation.....	3-107
ECU Power Supply Inspection.....	3-107
DFI Power Source.....	3-110
ECU Fuse Removal.....	3-110
ECU Fuse Installation.....	3-110
ECU Fuse Inspection.....	3-110

Warning Indicator Light (LED)	3-111
Light (LED) Inspection	3-111
Fuel Line	3-112
Fuel Pressure Inspection	3-112
Fuel Flow Rate Inspection	3-113
Fuel Pump	3-115
Fuel Pump Removal	3-115
Fuel Pump Installation	3-115
Operation Inspection	3-116
Operating Voltage Inspection	3-116
Fuel Injectors	3-118
Removal/Installation	3-118
Power Source Voltage Inspection	3-118
Output Voltage Inspection	3-119
Audible Inspection	3-120
Injector Signal Test	3-121
Injector Resistance Inspection	3-121
Injector Unit Test	3-122
Injector Fuel Line Inspection	3-122
Throttle Grip and Cables	3-124
Free Play Inspection	3-124
Free Play Adjustment	3-124
Cable Installation	3-124
Cable Lubrication	3-124
Throttle Body Assy	3-125
Idle Speed Inspection	3-125
Throttle Bore Cleaning	3-125
Synchronization Inspection	3-125
Synchronization Adjustment	3-125
Throttle Body Assy Removal	3-125
Throttle Body Assy Installation	3-127
Throttle Body Assy Disassembly	3-128
Throttle Body Assy Assembly	3-129
Air Line	3-131
Element Removal	3-131
Element Installation	3-131
Air Cleaner Element Inspection	3-131
Air Cleaner Housing Removal	3-131
Air Cleaner Housing Installation	3-132
Air Cleaner Housing Disassembly	3-133
Air Cleaner Housing Assembly	3-133
Oil Draining	3-133
Air Inlet Duct Removal	3-134
Air Inlet Duct Installation	3-134
Fuel Tank	3-135
Fuel Tank Removal	3-135
Fuel Tank Installation	3-137
Fuel Tank and Cap Inspection	3-138
Fuel Tank Cleaning	3-138
Evaporative Emission Control System	3-139
Parts Removal/Installation	3-139
Hose Inspection	3-139
Separator Inspection	3-139
Separator Operation Test	3-140
Canister Inspection	3-140

Exploded View

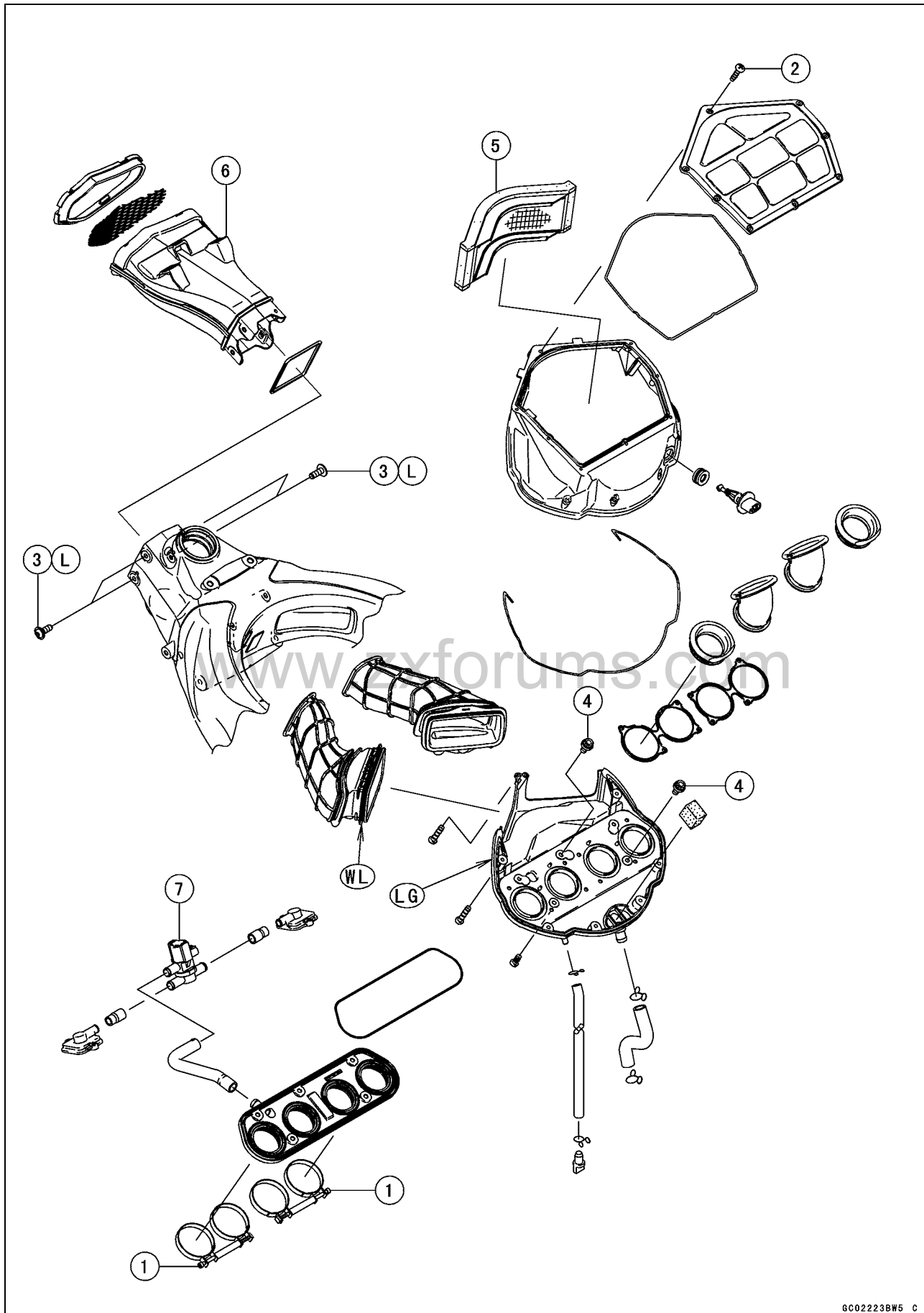

6C02223BW5 C

Exploded View

No.	Fastener	Torque			Remarks
		N·m	kgf·m	ft·lb	
1	Air Cleaner Housing Holder Clamp Screws	2.0	0.20	18 in·lb	
2	Air Cleaner Element Cover Screws	1.1	0.11	9.7 in·lb	
3	Air Inlet Duct Mounting Bolts	7.0	0.71	62 in·lb	L
4	Air Cleaner Housing Mounting Bolts	7.0	0.71	62 in·lb	

5. Air Cleaner Element

6. Air Inlet Duct

7. Air Switching Valve

L: Apply a non-permanent locking agent.

LG: Apply liquid gasket (Kawasaki Bond: 92104-0002).

WL: Apply a soap and water solution.

www.zxforums.com

Exploded View

No.	Fastener	Torque			Remarks
		N·m	kgf·m	ft·lb	
1	Speed Sensor Bolt	10	1.0	89 in·lb	
2	Crankshaft Sensor Bolts	6.0	0.61	53 in·lb	L
3	Gear Position Switch Screws	3.0	0.31	27 in·lb	L
4	Camshaft Position Sensor Bolt	10	1.0	89 in·lb	
5	Vehicle-down Sensor Bolts	6.0	0.61	53 in·lb	
6	Water Temperature Sensor	25	2.5	18	SS
7	Throttle Body Assy Holder Clamp Bolts	2.0	0.20	18 in·lb	S
8	Throttle Body Assy Holder Bolts	10	1.0	89 in·lb	S
9	Inlet Air Pressure Sensor Bracket Screws	3.5	0.36	31 in·lb	
10	Delivery Pipe Mounting Screws	5.0	0.51	44 in·lb	
11	Bypass Screws	0.2	0.02	17 in·lb	

12. Atmospheric Pressure Sensor

13. Inlet Air Pressure Sensor

14. Main Throttle Valve Sensor

15. Fuel Injectors

16. Subthrottle Valve Actuator

17. Subthrottle Valve Sensor

18. Throttle Cable (Accelerator)

19. Throttle Cable (Decelerator)

20. Relay Box

21. ECU

22. Stick Coils

CL: Apply cable lubricant.

EO: Apply engine oil.

G: Apply grease.

L: Apply a non-permanent locking agent.

R: Replacement Parts

S: Follow the specified tightening sequence.

SS: Apply silicone sealant (Kawasaki Bond: 92104-0004).

Exploded View

No.	Fastener	Torque			Remarks
		N·m	kgf·m	ft·lb	
1	Exhaust Butterfly Valve Actuator Mounting Bolts	0.8	0.08	7 in·lb	
2	Exhaust Butterfly Valve Actuator Pulley Bolt	5.0	0.50	44 in·lb	
3	Fuel Pump Bolts	10	1.0	89 in·lb	L, S
4	Canister Bracket Mounting Bolt (M5)	4.3	0.44	38 in·lb	
5	Canister Bracket Mounting Screws (M5)	4.3	0.44	38 in·lb	
6	Separator Bracket Mounting Bolts	7.0	0.71	62 in·lb	
7	Separator/Canister Hose Clamp Bolt	7.0	0.71	62 in·lb	

8 Canister

9 Separator

10 Fitting

11 Red Hose

12 Blue Hose

13 Green Hose

14 White Hose

L: Apply a non-permanent locking agent.

R: Replacement Parts

S: Follow the specified tightening sequence.

www.zxforums.com

DFI System

1. ECU
2. Crankshaft Sensor
3. Camshaft Position Sensor
4. Main Throttle Sensor
5. Subthrottle Sensor
6. Subthrottle Valve Actuator
7. Inlet Air Pressure Sensor
8. Atmospheric Pressure Sensor
9. Water Temperature Sensor
10. Inlet Air Temperature Sensor
11. Gear Position Switch
12. Vehicle-down Sensor
13. Fuel Injectors
14. Delivery Pipe
15. Pressure Regulator
16. Fuel Pump
17. Fuel Filter
18. Speed Sensor
19. Exhaust Butterfly Valve Actuator
20. Oxygen Sensors (Europe Models)
21. Battery 12 V 10 Ah
22. Air Flow
23. Fuel Flow

www.zxforums.com

Specifications

Item	Standard
Digital Fuel Injection System	
Idle Speed	1 100 ±50 r/min (rpm)
Throttle Assy:	
Type	Four barrel type
Bore	φ43 mm (1.7 in.)
Throttle Body Vacuum	31.5 ±1.3 kPa (236 ±10 mmHg)
Bypass Screws	- - -
ECU:	
Make	Mitsubishi Electric
Type	Digital memory type, with built in IC igniter, sealed with resin
Usable Engine Speed	100 ~ 12 987 r/min (rpm)
Fuel Pressure (high pressure line):	
Right after Ignition Switch ON, with fuel pump running for 4 seconds with engine idling	304 kPa (3.1 kgf/cm ² , 44 psi) with fuel pump running 280 kPa (2.9 kgf/cm ² , 41 psi) with fuel pump stopped 304 kPa (3.1 kgf/cm ² , 44 psi) with fuel pump running
Fuel Pump:	
Type	In-tank pump (in fuel tank), or Wesco pump (friction pump)
Discharge	72 mL (2.43 US oz.) or more for 4 seconds
Fuel Injectors:	
Type	INP-286
Nozzle Type	One spray type with 10 holes
Resistance	About 11.7 ~ 12.3 Ω at 20°C (68°F)
Main Throttle Sensor:	Non-adjustable and non-removable
Input Voltage	DC 4.75 ~ 5.25 V between BL and BR/BK leads
Output Voltage	DC 0.65 ~ 3.90 V between Y/W and BR/BK leads (at idle throttle opening to full throttle opening)
Resistance	4 ~ 6 kΩ
Inlet Air Pressure Sensor/Atmospheric Pressure Sensor:	
Input Voltage	DC 4.75 ~ 5.25 V between BL and BR/BK leads
Output Voltage	DC 3.80 ~ 4.20 V at standard atmospheric pressure (see this text for details)
Inlet Air Temperature Sensor:	
Resistance	2.09 ~ 2.81 kΩ at 20°C (68°F) About 0.322 kΩ at 80°C (176°F) (reference value)
Output Voltage at ECU	About 2.25 ~ 2.50 V at 20°C (68°F)
Water Temperature Sensor:	
Resistance	see Electrical System chapter
Output Voltage at ECU	About 2.80 ~ 2.97 V at 20°C (68°F)
Speed Sensor:	
Input Voltage at Sensor	DC 4.75 ~ 5.25 V between BL and BR/BK leads
Output Voltage at Sensor	About DC 0.05 ~ 0.09 V or DC 4.5 ~ 4.9 at Ignition Switch ON and 0 km/h
www.zxforums.com	www.zxforums.com
	www.zxforums.com

Specifications

Item	Standard
Vehicle-down sensor:	
Detection Method	Magnetic flux detection method
Detection Angle	More than 60 ~ 70° for each bank
Output Voltage	with sensor arrow mark pointed up: 3.55 ~ 4.45 V
	with sensor tilted 60 ~ 70° or more: 0.65 ~ 1.35 V
Subthrottle Sensor:	Non-adjustable and non-removal
Input Voltage	DC 4.75 ~ 5.25 V between BL and BR/BK leads
Output Voltage	DC 0.77 ~ 4.22 V between BL/W and BR/BK leads (at idle throttle opening to full throttle opening)
Resistance	4 ~ 6 kΩ
Exhaust Butterfly Valve Actuator Sensor:	
Resistance	4 ~ 6 kΩ
Immobilizer Antenna:	
Resistance	About 0.6 ~ 0.9 Ω
Exhaust Butterfly Valve Actuator:	
Output Voltage	3.46 ~ 3.76 V
Subthrottle Valve Actuator:	
Resistance	About 5 ~ 7 Ω
Input Voltage	About DC 10.5 ~ 12.5 V
Oxygen Sensors (Europe Models):	
Output Voltage (Rich)	0.45 ~ 2.5 V
Output Voltage (Lean)	0.05 ~ 0.45 V
Heater Resistance	About 8 Ω at 20°C (68°F)
Throttle Grip and Cables	
Throttle Grip Free Play	2 ~ 3 mm (0.08 ~ 0.12 in.)

Special Tools and Sealant

Oil Pressure Gauge, 5 kgf/cm²:
57001-125

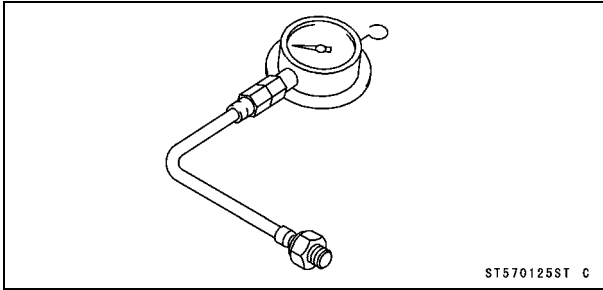

Peak Voltage Adapter:
57001-1415

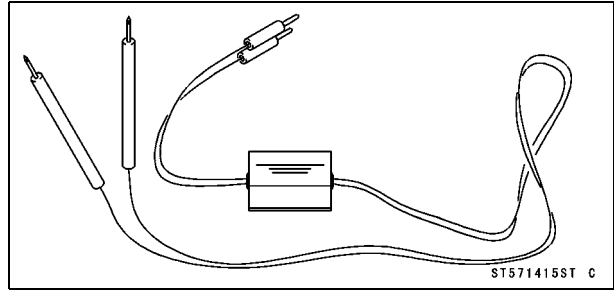

Fork Oil Level Gauge:
57001-1290

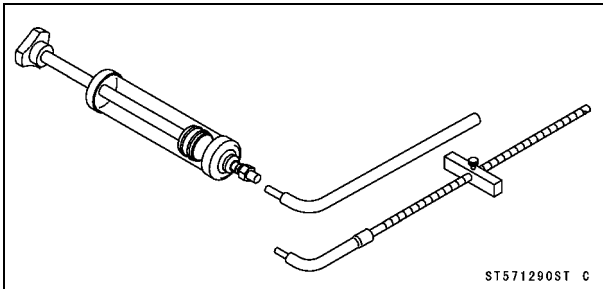

Needle Adapter Set:
57001-1457

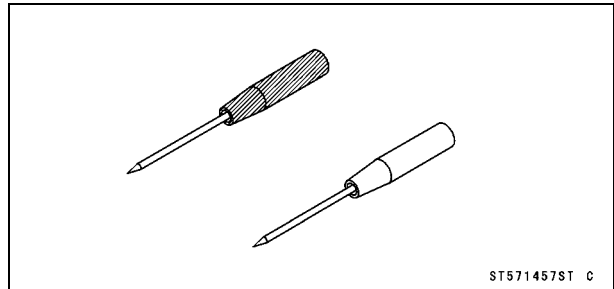

Vacuum Gauge:
57001-1369

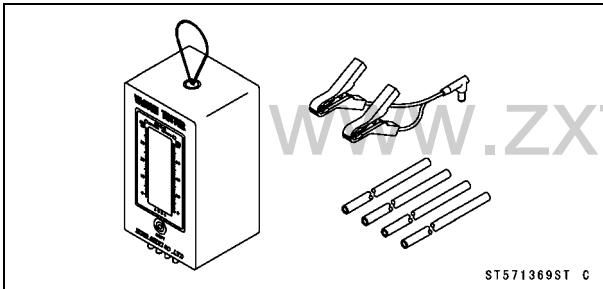

Throttle Sensor Setting Adapter:
57001-1538

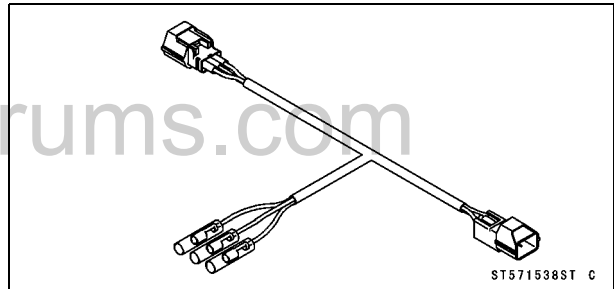

Hand Tester:
57001-1394

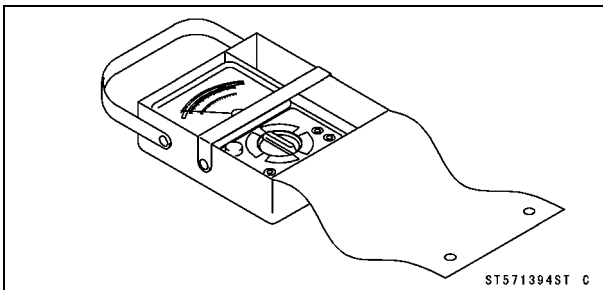

Sensor Harness Adapter:
57001-1561

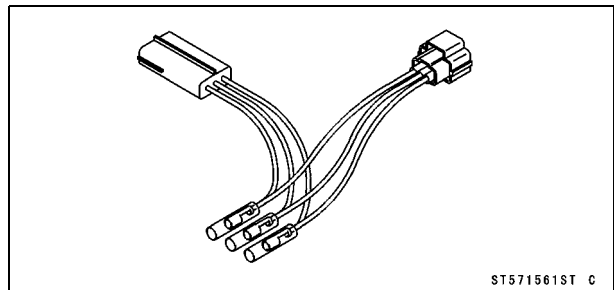

Throttle Sensor Setting Adapter #1:
57001-1400

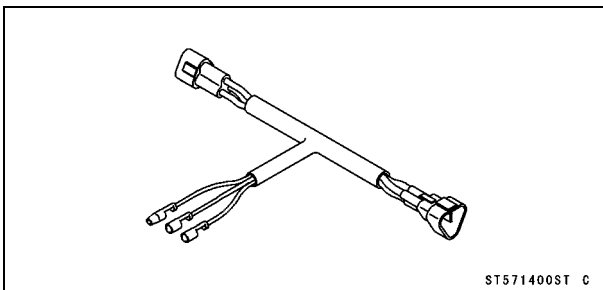

Extension Tube:
57001-1578

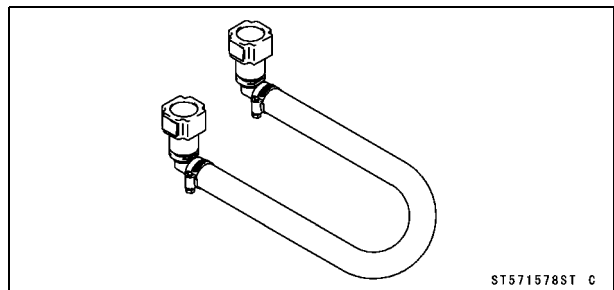

Special Tools and Sealant

**Fuel Pressure Gauge Adapter:
57001-1593**

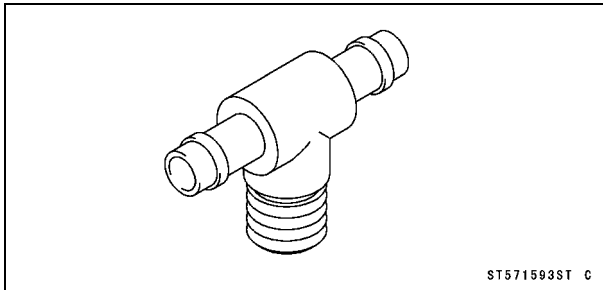

**Kawasaki Bond (Silicone Sealant):
56019-120**

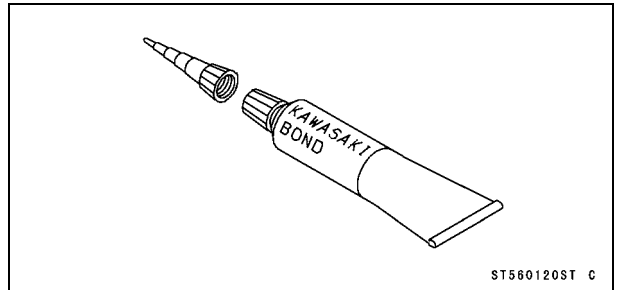

**Fuel Hose:
57001-1607**

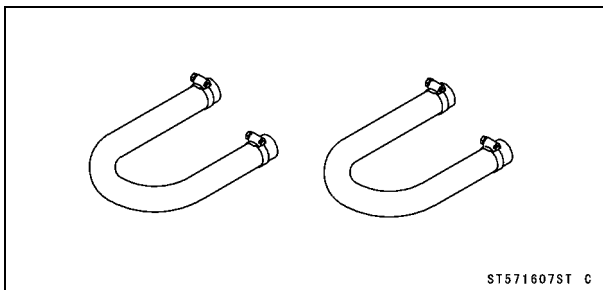

**Kawasaki Bond (Liquid Gasket - Black):
92104-0002**

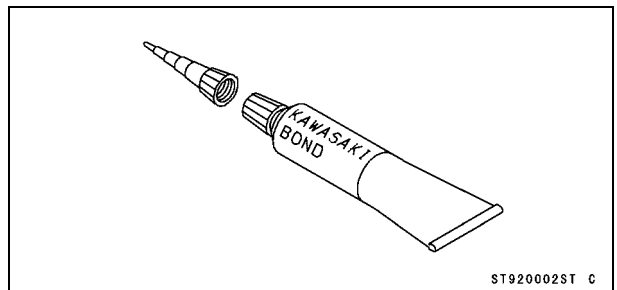

**Speed Sensor Measuring Adapter:
57001-1667**

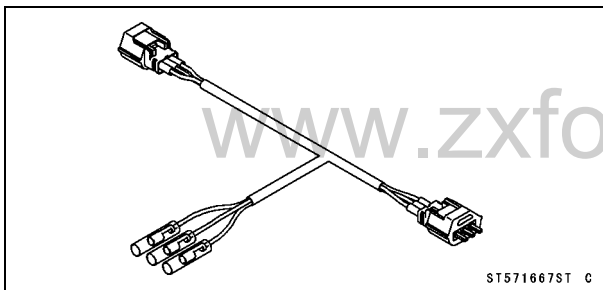

**Kawasaki Bond (Silicone Sealant):
92104-0004**

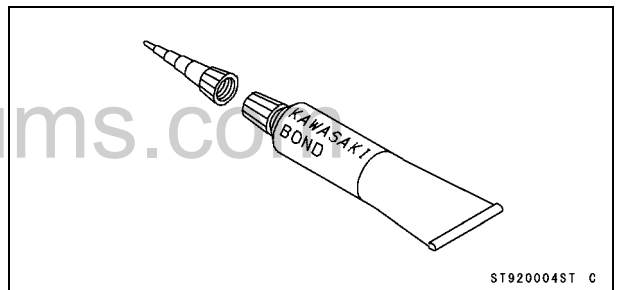

DFI Parts Location

- Main Throttle Sensor [A]
- Subthrottle Sensor [B]
- Subthrottle Valve Actuator [C]
- Inlet Air Pressure Sensor [D]
- Stick Coils #1, #2, #3, #4 [E]

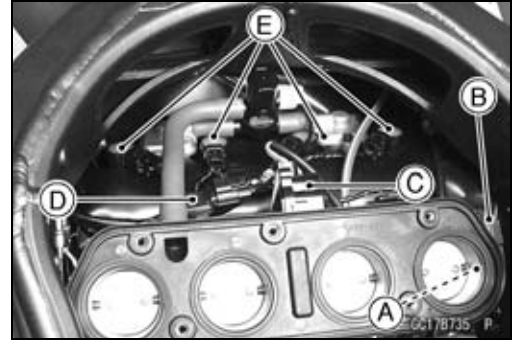

- Water Temperature Sensor [A]
- Fuel Injectors #1, #2, #3, #4 [B]

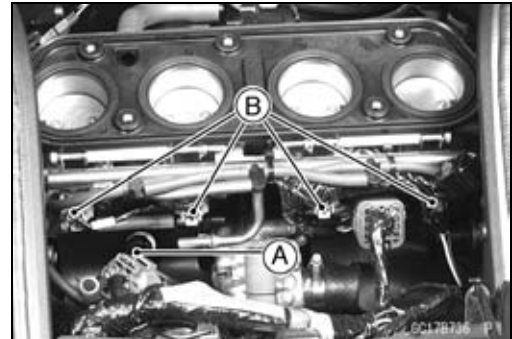

- Battery [A]
- Relay Box (Fuel Pump Relay) [B]
- Immobilizer/Kawasaki Diagnostic System Connector [C]
- ECU [D]

www.zxforums.com

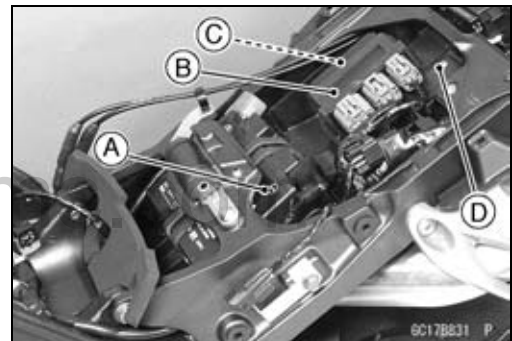

- Exhaust Butterfly Valve Actuator [A]
- Atmospheric Pressure Sensor [B]
- Vehicle-down Sensor [C]
- Fuse Box (ECU Fuse 15 A, Oxygen Sensor Heater Fuse 10 A) [D]

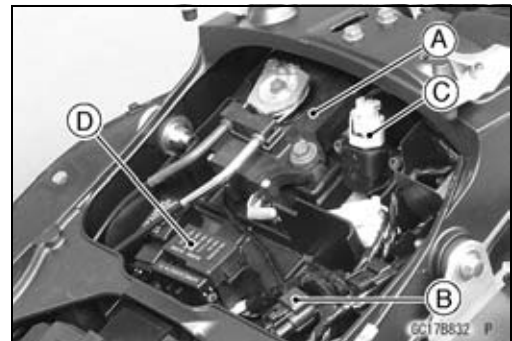

- Inlet Air Temperature Sensor [A]

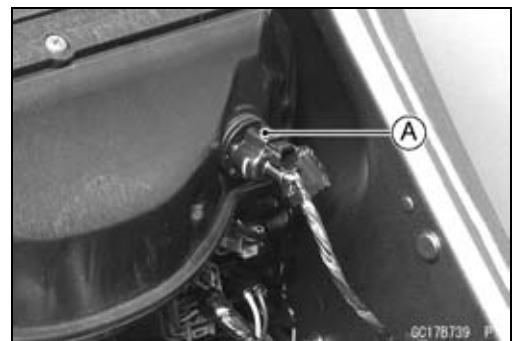

DFI Parts Location

Camshaft Position Sensor [A]
Crankshaft Sensor [B]

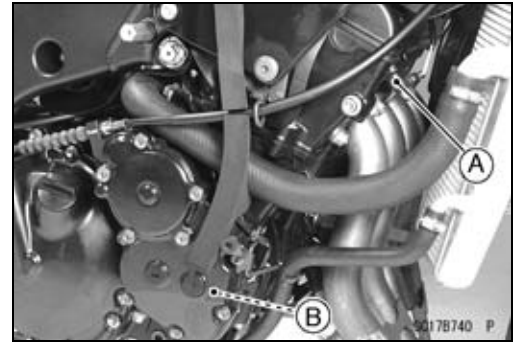

Speed Sensor [A]
Gear Position Switch [B]

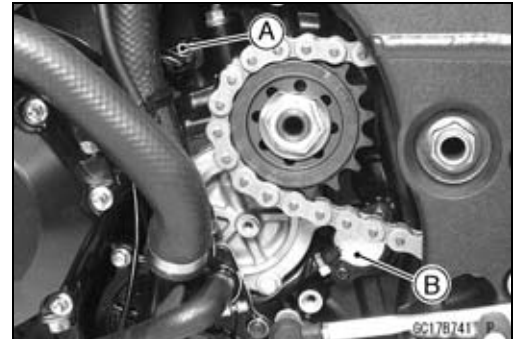

Ignition Key [A] (Transponder, Immobilizer Models)
Ignition Switch [B]
Immobilizer Antenna [C] (Immobilizer Models)
Immobilizer Amplifier [D] (Immobilizer Models)

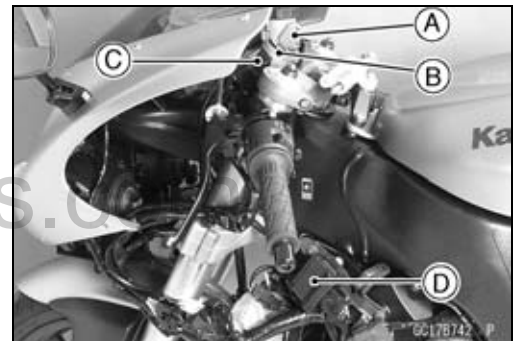

Oxygen Sensor #1 [A] (Europe Models)
Oxygen Sensor #2 [B] (Europe Models)

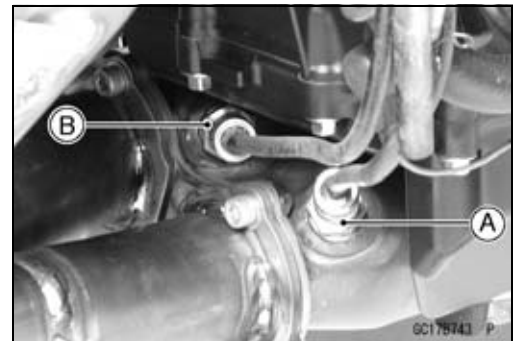

DFI System

DFI System Wiring Diagram

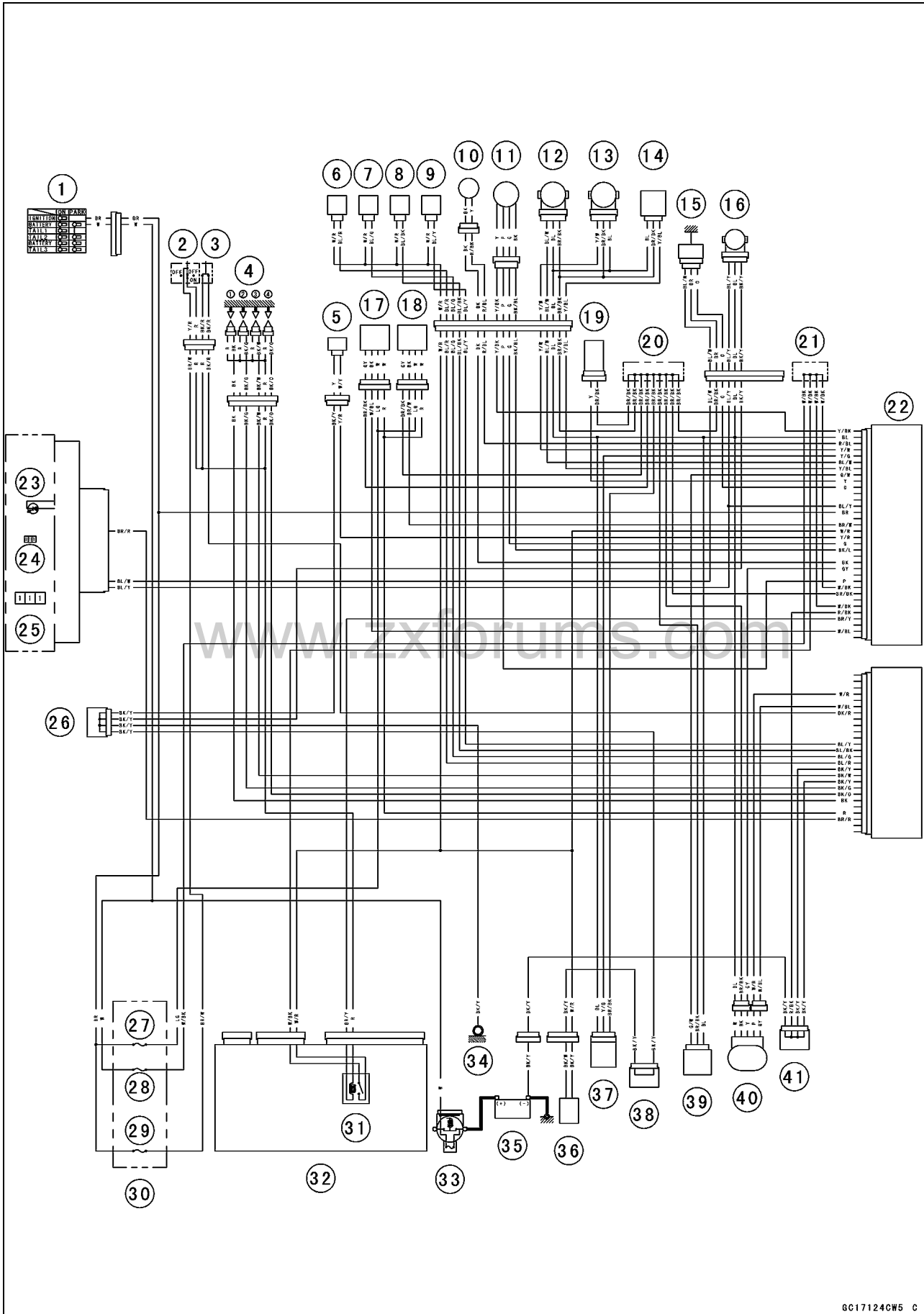

DFI System

Part Name

1. Ignition Switch
2. Engine Stop Switch
3. Starter Button
4. Stick Coil #1,#2,#3,#4
5. Camshaft Position Sensor
6. Injector #1
7. Injector #2
8. Injector #3
9. Injector #4
10. Crankshaft Sensor
11. Subthrottle Valve Actuator
12. Subthrottle Sensor
13. Main Throttle Sensor
14. Inlet Air Pressure Sensor
15. Water Temperature Sensor
16. Speed Sensor
17. Oxygen Sensor #1 (Europe Models)
18. Oxygen Sensor #2 (Europe Models)
19. Inlet Air Temperature Sensor
20. Water-proof Joint 2
21. Water-proof Joint 1
22. ECU
23. Warning Indicator Light (LED) (FI/Immobilizer)
24. Water Temperature Gauge
25. Speedometer
26. Joint Connector 1
27. Oxygen Sensor Heater Fuse 10 A (Europe Models)
28. ECU Fuse 15 A
29. Ignition Fuse 15 A
30. Fuse Box
31. Fuel Pump Relay
32. Relay Box
33. Main Fuse 30 A
34. Frame Ground
35. Battery 12 V 10 Ah
36. Fuel Pump
37. Vehicle-down Sensor
38. Joint Connector 2
39. Atmospheric Pressure Sensor
40. Exhaust Butterfly Valve Actuator
41. Joint Connector 3

○The ECU main replay function is included in the ECU.

DFI System

Terminal Numbers of ECU Connectors

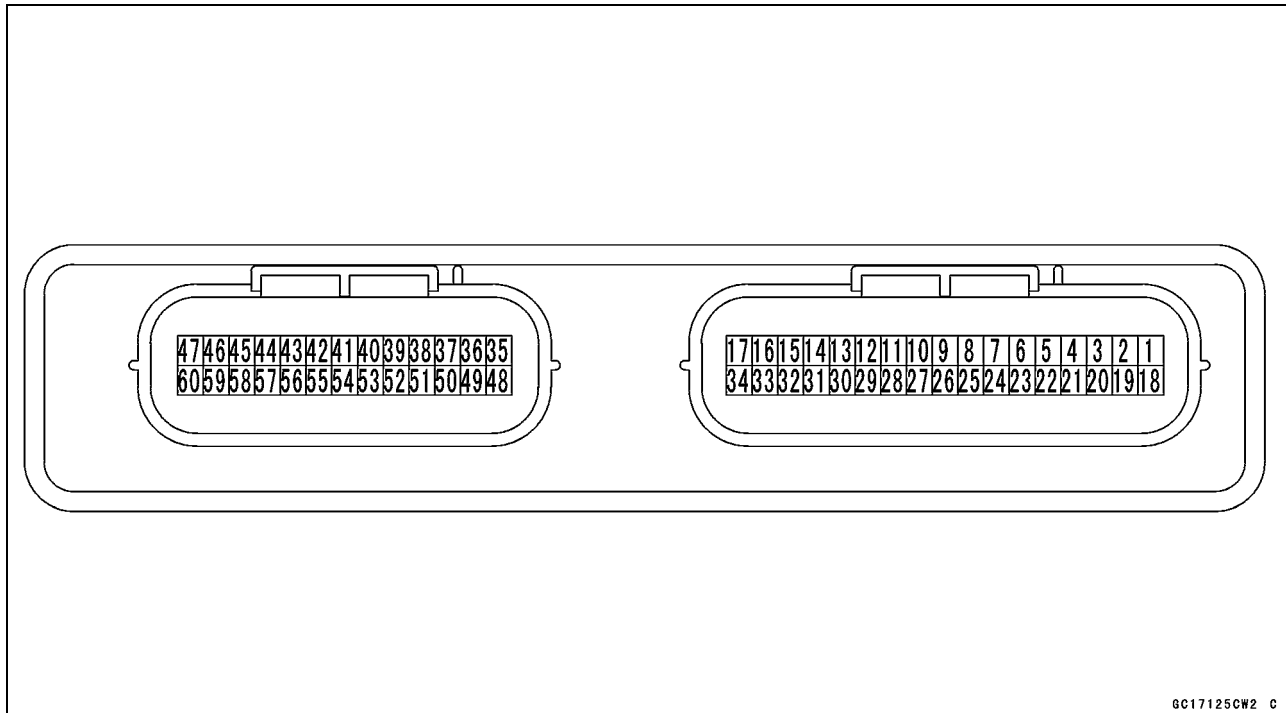

GC17125CW2 C

Terminal Names

1. Unused
2. Subthrottle Valve Actuator
3. Subthrottle Valve Actuator
4. Gear Position Switch
5. Crankshaft Sensor (-)
6. Speed Sensor
7. Power Supply to Sensors
8. Inlet Air Temperature Sensor
9. Vehicle-down Sensor
10. Exhaust Butterfly Valve Sensor
11. Atmospheric Pressure Sensor
12. Oxygen Sensor #2
13. Fuel Pump Relay
14. Battery Monitor
15. Power Supply to ECU (from Battery)
16. Unused
17. Ground for Control System
18. Unused
19. Subthrottle Valve Actuator
20. Subthrottle Valve Actuator
21. External Communication Line (Immobilizer/*KDS)
22. Crankshaft Sensor (+)
23. Unused
24. Camshaft Position Sensor
25. Water Temperature Sensor
26. Main Throttle Sensor
27. Subthrottle Sensor
28. Inlet Air Pressure Sensor
29. Oxygen Sensor #1
30. Radiator Fan Relay
31. Unused
32. Power Supply to ECU (from Battery)
33. Ignition Switch
34. Ground for Sensors

DFI System

35. External Communication Line (Immobilizer/*KDS)
36. Immobilizer Amplifier
37. Warning Indicator Light (LED) (FI/Immobilizer)
38. Air Switching Valve
39. Engine Ground
40. Starter Lockout Switch
41. Exhaust Butterfly Valve Actuator (-)
42. Starter Button
43. Unused
44. Injector #3
45. Stick Coil #3
46. Injector #1
47. Stick Coil #1
48. Unused
49. Immobilizer Amplifier
50. Immobilizer Amplifier
51. Meter Unit (Tachometer)
52. Engine Ground
53. Sidestand Switch
54. Exhaust Butterfly Valve Actuator (+)
55. Ground
56. Oxygen Sensor Heater
57. Injector #4
58. Stick Coil #4
59. Injector #2
60. Stick Coil #2

* KDS (Kawasaki Diagnostic System)

KDS that runs on Windows personal computer (PC) diagnostic tool for motorcycle with Kawasaki DFI system.

DFI Servicing Precautions

DFI Servicing Precautions

There are a number of important precautions that should be followed servicing the DFI system.

- This DFI system is designed to be used with a 12 V sealed battery as its power source. Do not use any other battery except for a 12 V sealed battery as a power source.
- Do not reverse the battery cable connections. This will damage the ECU.
- To prevent damage to the DFI parts, do not disconnect the battery cables or any other electrical connections when the ignition switch is on, or while the engine is running.
- Take care not to short the leads that are directly connected to the battery positive (+) terminal to the chassis ground.
- When charging, remove the battery from the motorcycle. This is to prevent ECU damage by excessive voltage.
- Whenever the DFI electrical connections are to be disconnected, first turn off the ignition switch, and disconnect the battery (–) terminal. Do not pull the lead, only the connector. Conversely, make sure that all the DFI electrical connections are firmly reconnected before starting the engine.
- Connect these connectors until they click [A]

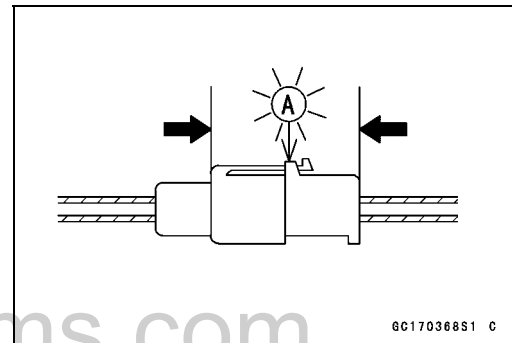

- Do not turn the ignition switch ON while any of the DFI electrical connectors are disconnected. The ECU memorizes service codes.
- Do not spray water on the electrical parts, DFI parts, connectors, leads, and wiring.
- If a transceiver is installed on the motorcycle, make sure that the operation of the DFI system is not influenced by electric wave radiated from the antenna. Check operation of the system with the engine at idle. Locate the antenna as far as possible away from the ECU.
- When any fuel hose is disconnected, do not turn on the ignition switch. Otherwise, the fuel pump will operate and fuel will spout from the fuel hose.
- Do not operate the fuel pump if the pump is completely dry. This is to prevent pump seizure.

DFI Servicing Precautions

- Before removing the fuel system parts, blow the outer surfaces of these parts clean with compressed air.
- When any fuel hose is disconnected, fuel may spout out by residual pressure in the fuel line. Cover the hose joint with a piece of clean cloth to prevent fuel spillage.
- When installing the fuel hoses, avoid sharp bending, kinking, flattening or twisting, and route the fuel hoses with a minimum of bending so that the fuel flow will not be obstructed.
- Route the hoses according to Cable, Wire, and Hose Routing section in the General Information chapter.
- To prevent corrosion and deposits in the fuel system, do not add to fuel any fuel antifreeze chemicals.
- Replace the fuel hose if it has been sharply bent or kinked.
- If the motorcycle is not properly handled, the high pressure inside the fuel line can cause fuel to leak or the hose [A] to burst. Bend and twist the fuel hose while examining it.
- ★ Replace the hose if any cracks or bulges are noticed.

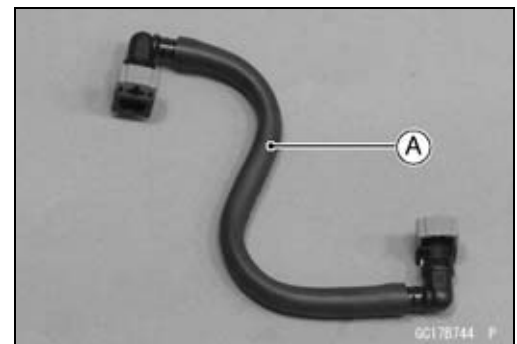

- To maintain the correct fuel/air mixture (F/A), there must be no inlet air leaks in the DFI system. Be sure to install the oil filler plug [A] after filling the engine oil.
Clutch Cover [B]

Torque - Oil Filler Plug: Hand-tighten

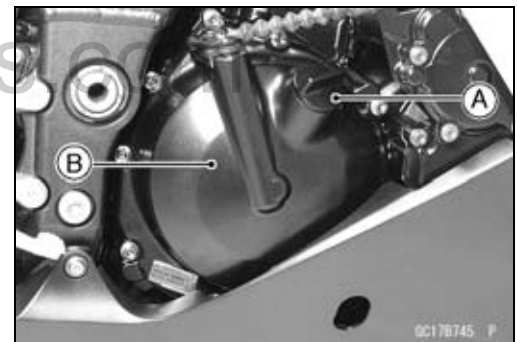

Troubleshooting the DFI System

The warning indicator light (LED) [A] is used for the FI indicator, immobilizer indicator (immobilizer models) and oil pressure warning indicator.

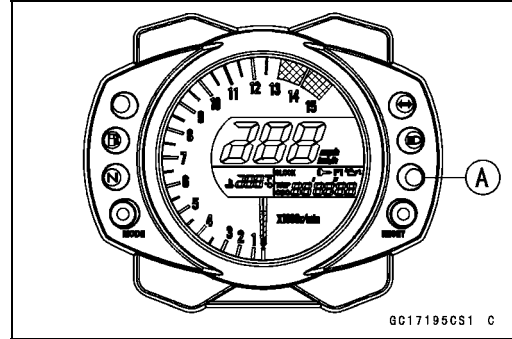

Outline

When a problem occurs with DFI system, the warning indicator light (LED) [A] and FI warning symbol [B] blinks to alert the rider. In addition, the condition of the problem is stored in the memory of the ECU. For models equipped with an immobilizer system, the warning indicator light (LED) and immobilizer warning symbol [C] blinks, when a problem occurs in the system.

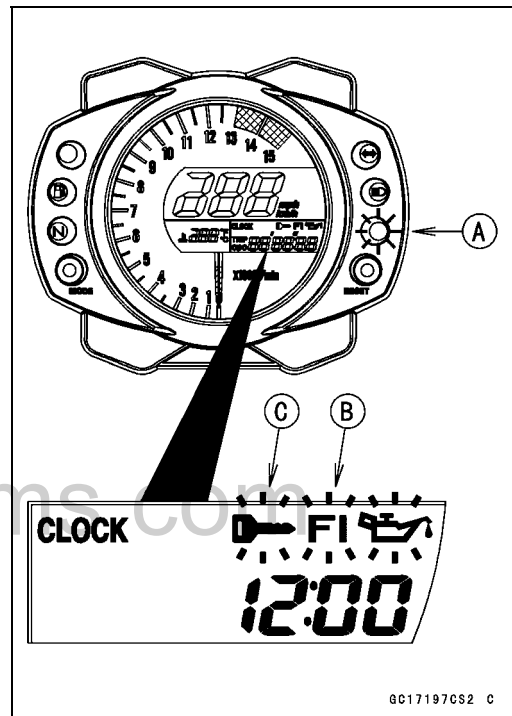

Troubleshooting the DFI System

With the engine stopped and turned in the self-diagnosis mode, the service code [A] is displayed on the LCD (Liquid Crystal Display) by the number of two digits.

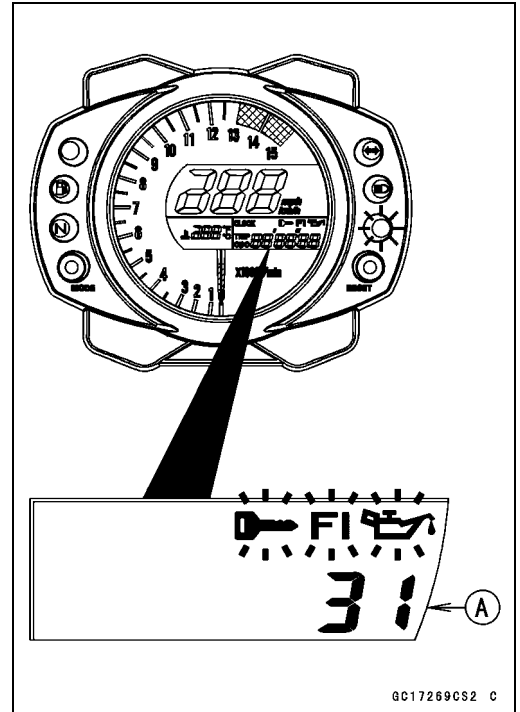

When the service code [A] is displayed, for first ask the rider about the conditions [B] of trouble, and then start to determine the cause of problem.

As a pre-diagnosis inspection, check the ECU for ground and power supply, the fuel line for no fuel leaks, and for correct pressure. The pre-diagnosis items are not indicated by the warning indicator light (LED) and FI warning symbol.

Don't rely solely on the DFI self-diagnosis function, use common sense.

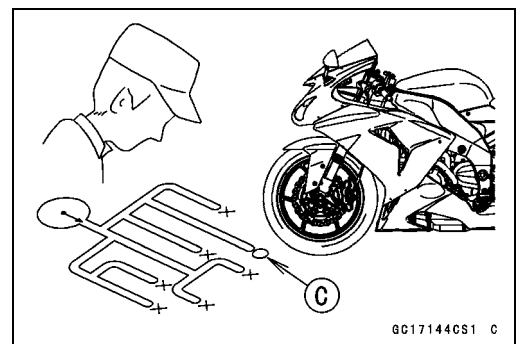
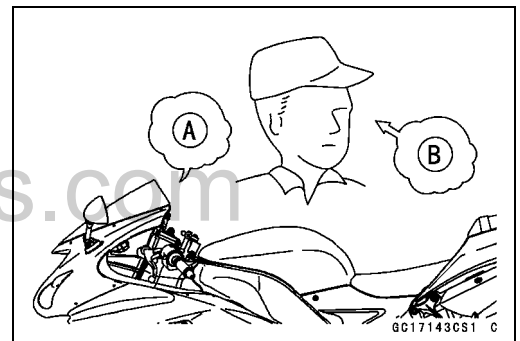

Even when the DFI system is operating normally, the warning indicator light (LED) and FI warning symbol may blink under strong electrical interference. Additional measures are not required. Turn the ignition switch OFF to stop the indicator light and symbol.

If the warning indicator light (LED) and FI warning symbol of the motorcycle brought in for repair still blinks, check the service code.

When the repair has been done, the FI warning symbol goes off. But the service codes stored in memory of the ECU are not erased to preserve the problem history. The problem history can be referred using the KDS (Kawasaki Diagnostic System) when solving unstable problems

Troubleshooting the DFI System

Much of the DFI system troubleshooting work consists of confirming continuity of the wiring. The DFI parts are assembled and adjusted with precision, and it is impossible to disassemble or repair them.

- When checking the DFI parts, use a digital meter which can be read two decimal place voltage or resistance.
- The DFI part connectors have seals, including the ECU. When measuring the input or output voltage with the connector joined, use the needle adapter set. Insert the needle adapter inside the seal until the needle adapter reaches the terminal.

Special Tool - Needle Adapter Set: 57001-1457

CAUTION

Insert the needle adapter straight along the terminal in the connector to prevent short-circuit between terminals.

- After measurement, remove the needle adapters and apply silicone sealant to the seals [A] of the connector [B] for waterproofing.

**Sealant - Kawasaki Bond (Silicone Sealant): 56019-120
-Seals of Connector**

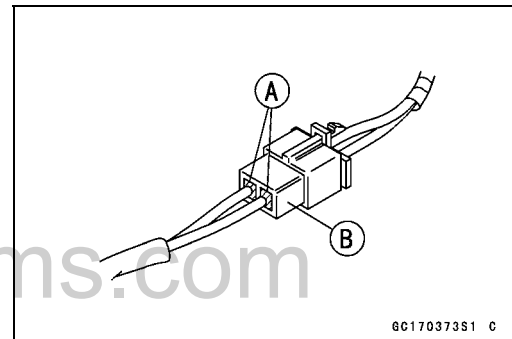

Troubleshooting the DFI System

- Always check battery condition before replacing the DFI parts. A fully charged battery is a must for conducting accurate tests of the DFI system.
- Trouble may involve one or in some cases all items. Never replace a defective part without determining what CAUSED the problem. If the problem was caused by some other item or items, they too must be repaired or replaced, or the new replacement part will soon fail again
- Measure coil winding resistance when the DFI part is cold (at room temperature)
- Do not adjust or remove the throttle sensor.
- Do not directly connect a 12 V battery to a fuel injector. Insert a resistor (5 ~ 7 Ω) or a bulb (12 V \times 3 ~ 3.4 W) in series between the battery and the injector.
- The DFI parts have been adjusted and set with precision. Therefore, they should be handled carefully, never strike sharply, as with a hammer, or allowed to drop on a hard surface. Such a shock to the parts can damage them.
- Check wiring and connections from the ECU connector to the suspected faulty DFI parts, using the hand tester (special tool, analog tester) rather than a digital tester.

Special Tool - Hand Tester: 57001-1394

- Make sure all connectors in the circuit are clean and tight, and examine wires for signs of burning, fraying, etc. Deteriorated leads and bad connections can cause reappearance of problems and unstable operation of the DFI system.
- ★ If any wiring is deteriorated, replace the wiring.
- Pull each connector [A] apart and inspect it for corrosion, dirt, and damage.
- ★ If the connector is corroded or dirty, clean it carefully. If it is damaged, replace it. Connect the connectors securely.
- Check the wiring for continuity.
- Use the wiring diagram to find the ends of the lead which is suspected of being a problem.
- Connect the hand tester between the ends of the leads.
- Set the tester to the $\times 1 \Omega$ range, and read the tester.
- ★ If the tester does not read 0 Ω , the lead is defective. Replace the lead or the main harness or the sub harness.

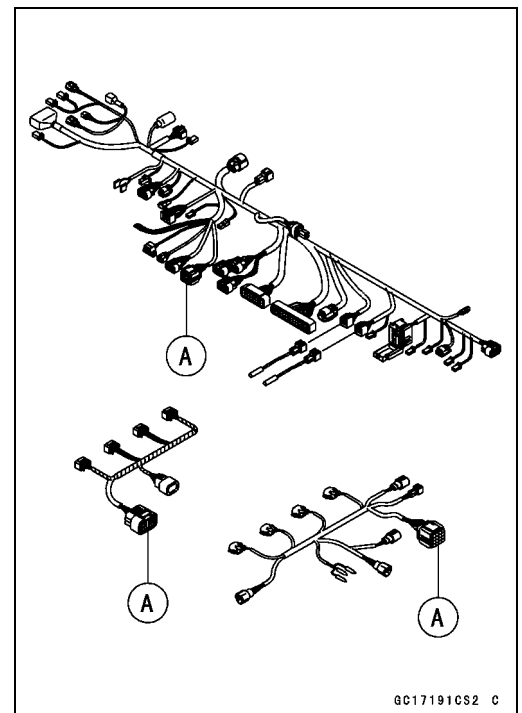

GC17191CS2 C

Troubleshooting the DFI System

○ If both ends of a harness [A] are far apart, ground [B] the one end [C], using a jumper lead [D] and check the continuity between the end [E] and the ground [F]. This enables to check a long harness for continuity. If the harness is open, repair or replace the harness.

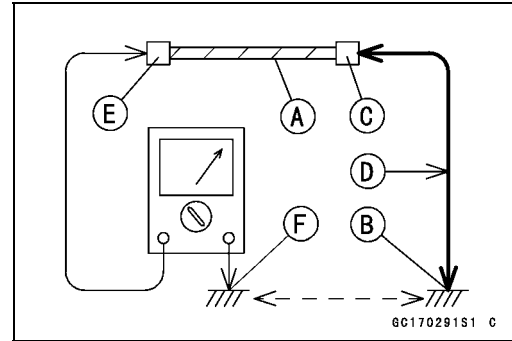

○ When checking a harness [A] for short circuit, open one end [B] and check the continuity between the other end [C] and ground [D]. If there is continuity, the harness has a short circuit to ground, and it must be repaired or replaced.

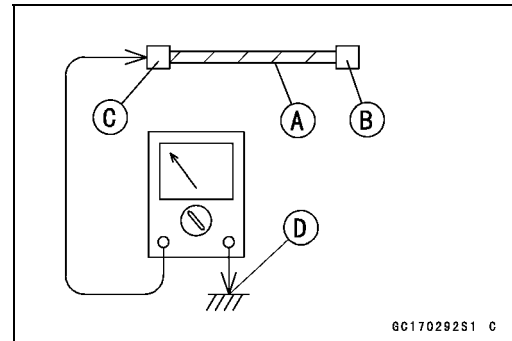

- Narrow down suspicious locations by repeating the continuity tests from the ECU connectors.
- ★ If no abnormality is found in the wiring or connectors, the DFI parts are the next likely suspects. Check the part, starting with input and output voltages. However, there is no way to check the ECU itself.
- ★ If an abnormality is found, replace the affected DFI part.
- ★ If no abnormality is found in the wiring, connectors, and DFI parts, replace the ECU.
- The diagnosis flow chart illustrates the above procedures.
- After inspection, be sure to connect all the DFI electrical connectors. Do not turn the ignition switch ON while the DFI electrical connectors and ignition system connectors are disconnected. Otherwise, the ECU memorizes service codes as open circuit.

○ Lead Color Codes:

BK: Black	G: Green	P: Pink
BL: Blue	GY: Gray	PU: Purple
BR: Brown	LB: Light Blue	R: Red
CH: Chocolate	LG: Light Green	W: White
DG: Dark Green	O: Orange	Y: Yellow

Troubleshooting the DFI System

- Electrical Connectors:
Female Connectors [A]

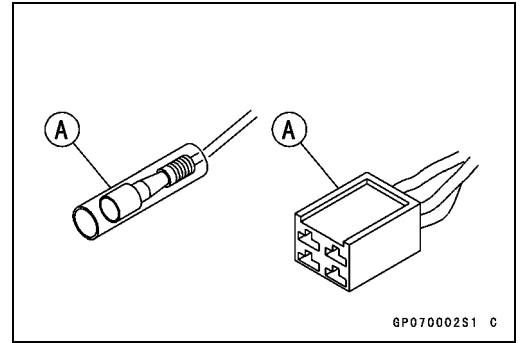

- Male Connectors [B]

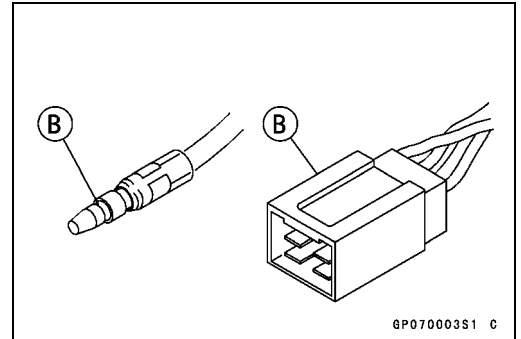

www.zxforums.com

Troubleshooting the DFI System

DFI Diagnosis Flow Chart

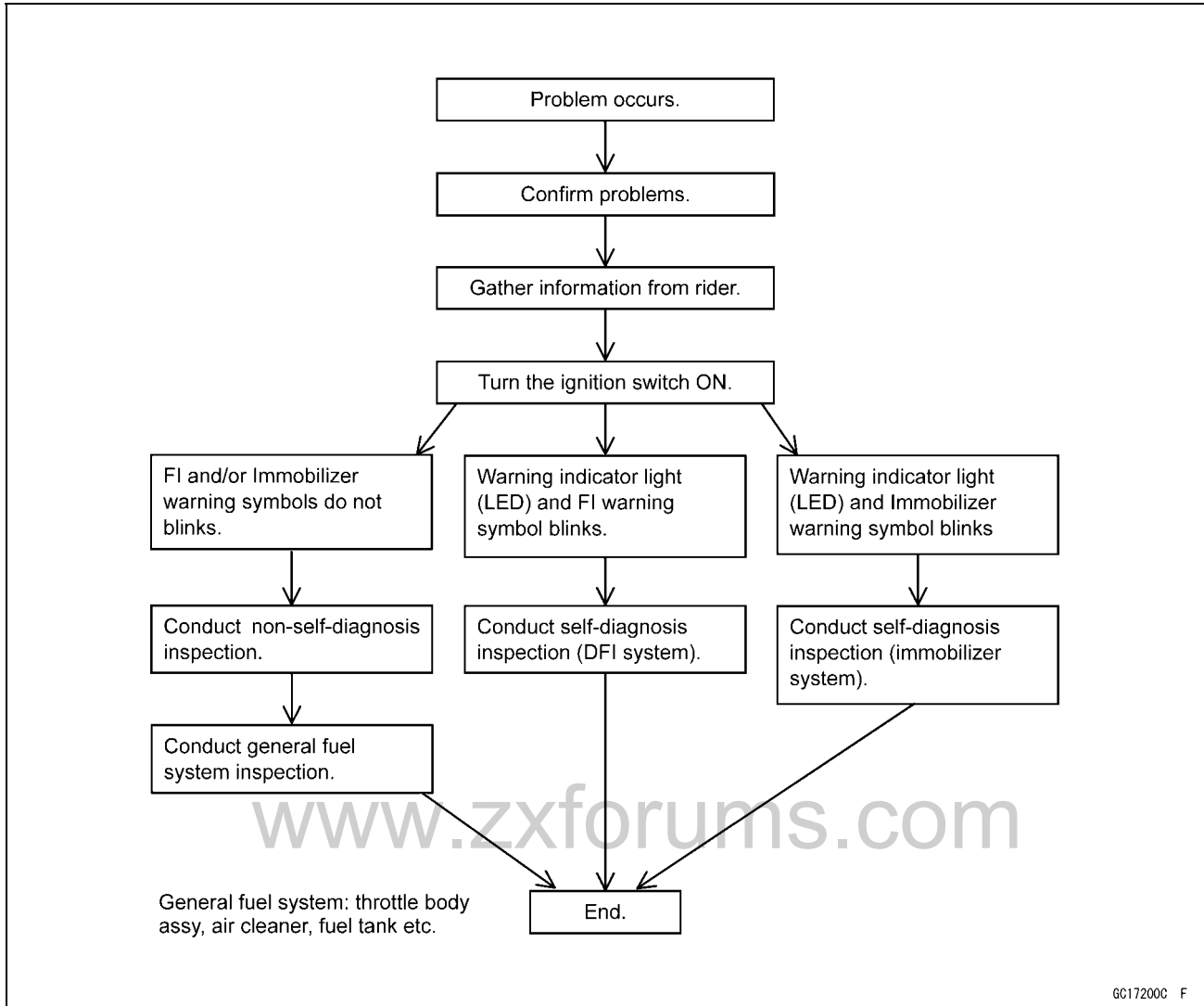

Inquiries to Rider

- Each rider reacts to problems in different ways, so it is important to confirm what kind of symptoms the rider has encountered.
- Try to find out exactly what problem occurred under exactly what conditions by asking the rider; knowing this information may help you reproduce the problem.
- The diagnosis sheet will help prevent you from overlooking any areas, and will help you decide if it is a DFI system problem, or a general engine problem.

Troubleshooting the DFI System**Sample Diagnosis Sheet**

Rider name:	Registration No. (license plate No.):	Year of initial registration:
Model:	Engine No.:	Frame No.:
Date problem occurred:		Mileage:
Environment when problem occurred.		
Weather	<input type="checkbox"/> fine, <input type="checkbox"/> cloudy, <input type="checkbox"/> rain, <input type="checkbox"/> snow, <input type="checkbox"/> always, <input type="checkbox"/> other:	
Temperature	<input type="checkbox"/> hot, <input type="checkbox"/> warm, <input type="checkbox"/> cold, <input type="checkbox"/> very cold, <input type="checkbox"/> always, <input type="checkbox"/> other:	
Problem frequency	<input type="checkbox"/> chronic, <input type="checkbox"/> often, <input type="checkbox"/> once	
Road	<input type="checkbox"/> street, <input type="checkbox"/> highway, <input type="checkbox"/> mountain road (<input type="checkbox"/> uphill, <input type="checkbox"/> downhill), <input type="checkbox"/> bumpy, <input type="checkbox"/> pebble	
Altitude	<input type="checkbox"/> normal, <input type="checkbox"/> high (about 1000 m or more)	
Motorcycle conditions when problem occurred.		
Warning indicator light (LED)	<input type="checkbox"/> Starts blinking about 3 seconds after from ignition switch ON, and goes off after engine pressure becomes high enough (with engine running).	
	<input type="checkbox"/> Starts blinking about 3 seconds after from ignition switch ON, and the FI warning symbol on the LCD starts blinking (DFI system problem).	
	<input type="checkbox"/> Starts blinking about 3 seconds after from ignition switch ON, and the immobilizer warning symbol on the LCD starts blinking (immobilizer system problem).	
	<input type="checkbox"/> Does not blink about 3 seconds after ignition switch ON.	
	<input type="checkbox"/> light up (ECU or meter unit replace).	
Starting difficulty	<input type="checkbox"/> starter motor not rotating.	
	<input type="checkbox"/> starter motor rotating but engine doesn't turn over.	
	<input type="checkbox"/> starter motor and engine don't turn over.	
	<input type="checkbox"/> no fuel flow (<input type="checkbox"/> no fuel in tank, <input type="checkbox"/> no fuel pump sound).	
	<input type="checkbox"/> engine flooded (do not crank engine with throttle opened, which promotes engine flooding).	
	<input type="checkbox"/> no spark.	
	<input type="checkbox"/> other:	
Engine stalls	<input type="checkbox"/> right after starting.	
	<input type="checkbox"/> when opening throttle grip.	
	<input type="checkbox"/> when closing throttle grip.	
	<input type="checkbox"/> when moving off.	
	<input type="checkbox"/> when stopping the motorcycle.	
	<input type="checkbox"/> when cruising.	
	<input type="checkbox"/> other:	

Troubleshooting the DFI System

Poor running at low speed	<input type="checkbox"/> very low idle speed, <input type="checkbox"/> very high idle speed, <input type="checkbox"/> rough idle speed.
	<input type="checkbox"/> battery voltage is low (charge the battery).
	<input type="checkbox"/> spark plug loose (tighten it).
	<input type="checkbox"/> spark plug dirty, broken, or gap maladjusted (remedy it).
	<input type="checkbox"/> backfiring.
	<input type="checkbox"/> afterfiring.
	<input type="checkbox"/> hesitation when acceleration.
	<input type="checkbox"/> engine oil viscosity too high.
	<input type="checkbox"/> brake dragging.
	<input type="checkbox"/> engine overheating.
	<input type="checkbox"/> clutch slipping.
<input type="checkbox"/> other:	
Poor running or no power at high speed	<input type="checkbox"/> spark plug loose (tighten it).
	<input type="checkbox"/> spark plug dirty, broken, or gap maladjusted (remedy it).
	<input type="checkbox"/> spark plug incorrect (replace it).
	<input type="checkbox"/> knocking (fuel poor quality or incorrect, → use high-octane gasoline).
	<input type="checkbox"/> brake dragging.
	<input type="checkbox"/> clutch slipping.
	<input type="checkbox"/> engine overheating.
	<input type="checkbox"/> engine oil level too high.
<input type="checkbox"/> engine oil viscosity too high.	
<input type="checkbox"/> other:	

DFI System Troubleshooting Guide**NOTE**

- This is not an exhaustive list, giving every possible cause for each problem listed. It is meant simply as a rough guide to assist the troubleshooting for some of the more common difficulties.
- The ECU may be involved in the DFI electrical and ignition system troubles. If these parts and circuits are checked out good, be sure to check the ECU for ground and power supply. If the ground and power supply are checked good, replace the ECU.

Engine Doesn't Start, Starting Difficulty

Symptoms or possible Causes	Actions (chapter)
Starter motor not rotating:	
Ignition and engine stop switches not ON	Turn both switches ON.
Starter lockout switch or neutral switch trouble	Inspect (see chapter 16).
Starter motor trouble	Inspect (see chapter 16).
Battery voltage low	Inspect and charge (see chapter 16).
Starter relays not contacting or operating	Inspect the starter relay (see chapter 16).
Starter button not contacting	Inspect and replace (see chapter 16).
Starter system wiring open or shorted	Inspect the wiring (see chapter 16).
Ignition switch trouble	Inspect and replace (see chapter 16).
Engine stop switch trouble	Inspect and repair or replace (see chapter 16).
Main 30 A or ignition fuse blown	Inspect and replace (see chapter 16).
Starter motor rotating but engine doesn't turn over:	
Starter clutch trouble	Inspect (see chapter 16).
Starter idle gear trouble	Inspect (see chapter 16).
Engine won't turn over:	
Valve seizure	Inspect and replace (see chapter 5).
Cylinder, piston seizure	Inspect and replace (see chapter 5).
Camshaft seizure	Inspect and replace (see chapter 5).
Connecting rod small end seizure	Inspect and replace (see chapter 9).
Connecting rod big end seizure	Inspect and replace (see chapter 9).
Crankshaft seizure	Inspect and replace (see chapter 9).
Transmission gear or bearing seizure	Inspect and replace (see chapter 9).
Balancer bearing seizure	Inspect and replace (see chapter 9).
No fuel flow:	
No or little fuel in tank	Supply fuel (see Owner's Manual).
Fuel pump not rotating	Inspect (see chapter 3).
Fuel injector trouble	Inspect and replace (see chapter 3).
Fuel tank air vent obstructed	Inspect and repair (see chapter 3).
Fuel filter or pump screen clogged	Inspect and replace fuel pump (see chapter 3).
Fuel pressure regulator clogged	Inspect and replace fuel pump (see chapter 3).
Fuel line clogged	Inspect and repair (see chapter 3).
Engine flooded:	
Spark plug dirty, broken or gap maladjusted	Replace (see chapter 2).
Starting technique faulty	When flooded, don't crank engine with throttle fully opened.
No spark or spark weak:	
Ignition and engine stop switches not ON	Turn both switches ON .

DFI System Troubleshooting Guide

Symptoms or possible Causes	Actions (chapter)
Clutch lever not pulled in and gear not in neutral whether sidestand up or not	Pull the lever in and shift the gear in neutral.
Though clutch lever pulled in, sidestand up and gear not in neutral	Sidestand down and clutch lever pulled in whether gear in neutral or not
Vehicle-down sensor coming off	Reinstall (see chapter 3).
Vehicle-down sensor trouble	Inspect (see chapter 3) .
ECU ground or power supply trouble	Inspect (see chapter 3) .
Battery voltage low	Inspect and charge (see chapter 16).
Spark plug dirty, broken or gap maladjusted	Replace (see chapter 2).
Spark plug cap trouble	Inspect stick coil (see chapter 16).
Spark plug cap shorted or not in good contact	Reinstall or inspect stick coil (see chapter 16).
Spark plug incorrect	Replace it with the correct plug (see chapter 16).
IC igniter in ECU trouble	Inspect (see chapter 16).
Neutral, starter lockout or sidestand switch trouble	Inspect each switch (see chapter 16).
Crankshaft sensor trouble	Inspect (see chapter 16).
Stick coil trouble	Inspect (see chapter 16).
Ignition switch shorted	Inspect and replace (see chapter 16).
Engine stop switch shorted	Inspect and repair or replace (see chapter 2) .
Starter system wiring shorted or open	Inspect and repair or replace (see chapter 16).
Main 30 A or ignition fuse blown	Inspect and replace (see chapter 16).
Fuel/air mixture incorrect:	
Air cleaner clogged, poorly sealed or missing	Clean or reinstall (see chapter 3).
Leak from oil filler cap, crankcase breather hose or air cleaner drain hose	Inspect and repair or replace (see chapter 3).
Water or foreign matter in fuel	Change fuel. Inspect and clean fuel system (see chapter 3).
Fuel pressure regulator trouble	Inspect fuel pressure and replace fuel pump (see chapter 3).
Main throttle sensor trouble	Inspect (see chapter 3).
Fuel pressure may be low	Inspect (see chapter 3).
Fuel pump trouble	Inspect (see chapter 3).
Fuel injector trouble	Inspect (see chapter 3).
Inlet air pressure sensor trouble	Inspect (see chapter 3).
Atmospheric pressure sensor trouble	Inspect (see chapter 3).
Inlet air temperature sensor trouble	Inspect (see chapter 3).
Water temperature sensor trouble	Inspect (see chapter 3).
Crankshaft sensor trouble	Inspect (see chapter 3).
Compression low:	
Spark plug loose	Reinstall (see chapter 16).
Cylinder head not sufficiently tightened down	Tighten (see chapter 5).
Cylinder, piston worn	Inspect and replace (see chapter 5).
Piston ring bad (worn, weak, broken or sticking)	Inspect and replace (see chapter 5).
Piston ring/groove clearance excessive	Inspect and replace (see chapter 5).
Cylinder head gasket damaged	Replace (see chapter 5).

DFI System Troubleshooting Guide

Symptoms or possible Causes	Actions (chapter)
Cylinder head warped	Inspect and replace (see chapter 5).
No valve clearance	Adjust (see chapter 2).
Valve guide worn	Inspect and replace (see chapter 5).
Valve spring broken or weak	Inspect and replace (see chapter 5).
Valve not seating properly (valve bent, worn or carbon accumulating on seating surface)	Inspect and repair or replace (see chapter 5).

Poor Running at Low Speed

Symptoms or Possible Causes	Actions (chapter)
Spark weak:	
Battery voltage low	Inspect and charge (see chapter 16).
Spark plug dirty, broken or gap maladjusted	Replace (see chapter 2).
Spark plug cap trouble	Inspect the stick coil (see chapter 16).
Spark plug cap shorted or not in good contact	Reinstall or inspect stick coil (see chapter 16).
Spark plug incorrect	Replace it with the correct plug (see chapter 16).
IC igniter in ECU trouble	Inspect (see chapter 16).
Crankshaft sensor trouble	Inspect (see chapter 16).
Stick coil trouble	Inspect (see chapter 16).
Fuel/air mixture incorrect:	
Little fuel in tank	Supply fuel (see Owner's Manual).
Air cleaner clogged, poorly sealed, or missing	Clean element or inspect sealing (see chapter 2, 3).
Air cleaner duct loose	Reinstall (see chapter 3).
Air cleaner O-ring damaged	Replace (see chapter 3).
Fuel tank air vent obstructed	Inspect and repair (see chapter 3).
Throttle body assy loose	Reinstall (see chapter 3).
Throttle body assy O-ring damage	Replace (see chapter 3).
Fuel filter or pump screen clogged	Inspect and replace fuel pump (see chapter 3).
Fuel pressure regulator clogged	Inspect fuel pressure and replace fuel pump (see chapter 3).
Fuel line clogged	Inspect and repair (see chapter 3).
Inlet air pressure sensor trouble	Inspect (see chapter 3).
Inlet air temperature sensor trouble	Inspect (see chapter 3).
Thermostat trouble	Inspect and replace (see chapter 4).
Unstable (rough) idling:	
Fuel injector trouble	Inspect (see chapter 3).
Main throttle sensor trouble	Inspect (see chapter 3).
Crankshaft sensor trouble	Inspect (see chapter 3).
Throttle valves not synchronizing	Inspect (see chapter 2).
Inlet air temperature sensor trouble	Inspect (see chapter 3).
Water temperature sensor trouble	Inspect (see chapter 3).
Atmospheric pressure sensor trouble	Inspect (see chapter 3).
Fuel pressure too low or too high	Inspect (see chapter 3).
Battery voltage low	Inspect and charge (see chapter 16).

DFI System Troubleshooting Guide

Symptoms or Possible Causes	Actions (chapter)
Incorrect idle speed:	
Water temperature sensor trouble	Inspect (see chapter 3).
Main throttle sensor trouble	Inspect (see chapter 3).
Engine stalls easily:	
Fuel pump trouble	Inspect (see chapter 3).
Fuel injector trouble	Inspect (see chapter 3).
Main throttle sensor trouble	Inspect (see chapter 3).
Camshaft position sensor trouble	Inspect (see chapter 3).
Fuel pressure too low or too high	Inspect (see chapter 3).
Inlet air pressure sensor trouble	Inspect (see chapter 3).
Water temperature sensor trouble	Inspect (see chapter 3).
Inlet air temperature sensor trouble	Inspect (see chapter 3).
Fuel line clogged	Inspect and repair (see chapter 3).
Fuel pressure too low or too high	Inspect (see chapter 3).
Fuel pressure regulator trouble	Inspect fuel pressure and replace fuel pump (see chapter 3).
Crankshaft sensor trouble	Inspect (see chapter 16).
Stick coil trouble	Inspect (see chapter 16).
Compression Low:	
Spark plug loose	Reinstall (see chapter 16).
Cylinder head not sufficiently tightened down	Tighten (see chapter 5).
No valve clearance	Adjust (see chapter 2).
Cylinder, piston worn	Inspect and replace (see chapter 5).
Piston ring bad (worn, weak, broken or sticking)	Inspect and replace (see chapter 5).
Piston ring/groove clearance excessive	Inspect and replace (see chapter 5).
Cylinder head gasket damaged	Replace (see chapter 5).
Cylinder head warped	Inspect and replace (see chapter 5).
Valve guide worn or stem seal damaged	Inspect and replace (see chapter 5).
Valve spring broken or weak	Inspect and replace (see chapter 5).
Valve not seating properly (valve bent, worn or carbon accumulating on seating surface)	Inspect and repair or replace (see chapter 5).
Camshaft cam worn	Inspect and replace (see chapter 5).
Hesitation:	
Too low fuel pressure	Inspect (see chapter 3).
Clogged fuel line	Inspect and repair (see chapter 3).
Cracked or obstructed inlet air pressure sensor hose	Inspect and repair or replace (see chapter 3).
Fuel pump trouble	Inspect (see chapter 3).
Fuel injector trouble	Inspect (see chapter 3).
Inlet air temperature sensor trouble	Inspect (see chapter 3).
Main throttle sensor trouble	Inspect (see chapter 3).
Subthrottle sensor trouble	Inspect (see chapter 3).
Subthrottle valve actuator trouble	Inspect (see chapter 3).
Water temperature sensor trouble	Inspect (see chapter 3).
Atmospheric pressure sensor trouble	Inspect (see chapter 3).

DFI System Troubleshooting Guide

Symptoms or Possible Causes	Actions (chapter)
Inlet air pressure sensor trouble	Inspect (see chapter 3).
Loose injector connectors	Remedy (see chapter 3).
Crankshaft sensor trouble	Inspect and repair or replace (see chapter 16).
Stick coil trouble	Inspect and repair or replace (see chapter 16).
Loose terminal of battery (-) lead or engine ground lead	Inspect and repair (see chapter 16).
Delay of ignition timing	Inspect crankshaft sensor and IC igniter in ECU (see chapter 16).
Poor acceleration:	
Too low fuel pressure	Inspect (see chapter 3).
Water or foreign matter in fuel	Change fuel. Inspect and clean fuel system (see chapter 3).
Clogged fuel filter or pump screen	Inspect and replace fuel pump (see chapter 3).
Fuel pump trouble	Inspect (see chapter 3).
Fuel injector trouble	Inspect (see chapter 3).
Inlet air temperature sensor trouble	Inspect (see chapter 3).
Water temperature sensor trouble	Inspect (see chapter 3).
Atmospheric pressure sensor trouble	Inspect (see chapter 3).
Subthrottle sensor trouble	Inspect (see chapter 3).
Subthrottle valve actuator trouble	Inspect (see chapter 3).
Stick coil trouble	Inspect and replace (see chapter 16).
Engine oil level too high	Repair (see chapter 7).
Spark plug dirty, broken or gap maladjusted	Replace (see chapter 2).
Stumble:	
Too low fuel pressure	Inspect (see chapter 3).
Fuel injector trouble	Inspect (see chapter 3).
Main throttle sensor malfunction	Inspect (see chapter 3).
Subthrottle sensor trouble	Inspect (see chapter 3).
Subthrottle valve actuator trouble	Inspect (see chapter 3).
Water temperature sensor trouble	Inspect (see chapter 3).
Inlet air pressure sensor trouble	Inspect (see chapter 3).
Surge:	
Unstable fuel pressure	Fuel pressure regulator trouble (Inspect and replace fuel pump) or kinked fuel line (Inspect and repair fuel line) (see chapter 3).
Fuel injector trouble	Inspect (see chapter 3).
Water temperature sensor trouble	Inspect (see chapter 3).
Backfiring when deceleration:	
Spark plug dirty, broken or gap maladjusted	Replace (see chapter 2).
Too low fuel pressure	Inspect (see chapter 3).
Fuel pump trouble	Inspect (see chapter 3).
Main throttle sensor trouble	Inspect (see chapter 3).
Inlet air temperature sensor trouble	Inspect (see chapter 3).
Water temperature sensor trouble	Inspect (see chapter 3).
Atmospheric pressure sensor trouble	Inspect (see chapter 3).

DFI System Troubleshooting Guide

Symptoms or Possible Causes	Actions (chapter)
Inlet air pressure sensor trouble	Inspect (see chapter 3).
Air switching valve broken	Inspect and replace (see chapter 5).
Air suction valve trouble	Inspect and replace (see chapter 5).
After fire:	
Crankshaft sensor trouble	Inspect (see chapter 16).
Spark plug burned or gap maladjusted	Replace (see chapter 2).
Inlet air temperature sensor trouble	Inspect (see chapter 3).
Water temperature sensor trouble	Inspect (see chapter 3).
Atmospheric pressure sensor trouble	Inspect (see chapter 3).
Inlet air pressure sensor trouble	Inspect (see chapter 3).
Fuel injector trouble	Inspect (see chapter 3).
Run-on (dieseling):	
Ignition switch trouble	Inspect and replace (see chapter 16).
Engine stop switch trouble	Inspect and repair or replace (see chapter 2).
Fuel injector trouble	Inspect (see chapter 3).
Loose terminal of battery (-) cable or ECU ground lead	Inspect and repair (see chapter 16).
Carbon accumulating on valve seating surface	Repair (see chapter 5).
Engine overheating	(see Overheating of Troubleshooting Guide, see chapter 17)
Other:	
Engine oil viscosity too high	Change (see chapter 2).
Drive train trouble	Inspect drive chain (see chapter 2) and sprocket (see chapter 11).
Brake dragging	Inspect caliper fluid seal damage or clogging of master cylinder relief and supply ports (see chapter 12).
Clutch slipping	Inspect friction plates for wear (see chapter 6).
Engine overheating	(see Overheating of Troubleshooting Guide, see chapter 17)
Air switching valve trouble	Inspect and replace (see chapter 5).
Air suction valve trouble	Inspect and replace (see chapter 5).
Intermittent any DFI fault and its recovery	Check that DFI connectors are clean and tight, and examine wires for signs of burning or fraying (see chapter 3).

Poor Running or No Power at High Speed:

Symptoms or Possible Causes	Actions (chapter)
Firing incorrect:	
Spark plug dirty, broken or maladjusted	Replace (see chapter 2).
Spark plug cap trouble	Inspect stick coil (see chapter 16).
Spark plug cap shorted or not in good contact	Reinstall or inspect stick coil (see chapter 16).
Spark plug incorrect	Replace it with the correct plug (see chapter 16).
IC igniter in ECU trouble	Inspect (see chapter 16).
Crankshaft sensor trouble	Inspect (see chapter 16).

DFI System Troubleshooting Guide

Symptoms or Possible Causes	Actions (chapter)
Stick coil trouble	Inspect (see chapter 16).
Fuel/air mixture incorrect:	
Air cleaner clogged, poorly sealed, or missing	Clean element or inspect sealing (see chapter 3).
Air cleaner duct loose	Reinstall (see chapter 3).
Air cleaner O-ring damaged	Replace (see chapter 3).
Water or foreign matter in fuel	Change fuel. Inspect and clean fuel system (see chapter 3).
Throttle body assy loose	Reinstall (see chapter 3).
Throttle body assy O-ring damaged	Replace (see chapter 3).
Fuel tank air vent obstructed	Inspect and repair (see chapter 3).
Fuel line clogged	Inspect and repair (see chapter 3).
Fuel pump operates intermittently and often DFI fuse blows.	Pump bearings may wear. Replace the pump (see chapter 3).
Fuel pump trouble	Inspect (see chapter 3).
Inlet air temperature sensor trouble	Inspect (see chapter 3).
Main throttle sensor trouble	Inspect (see chapter 3).
Atmospheric pressure sensor trouble	Inspect (see chapter 3).
Inlet air pressure sensor trouble	Inspect (see chapter 3).
Cracked or obstructed inlet air pressure sensor hose	Inspect and repair or replace (see chapter 3).
Injector clogged	Visually inspect and replace (see chapter 3).
Compression low:	
Spark plug loose	Reinstall (see chapter 16).
Cylinder head not sufficiently tightened down	Tighten (see chapter 5).
No valve clearance	Adjust (see chapter 2).
Cylinder, piston worn	Inspect and replace (see chapter 5).
Piston ring bad (worn, weak, broken or sticking)	Inspect and replace (see chapter 5).
Piston ring /groove clearance excessive	Inspect and replace (see chapter 5).
Cylinder head gasket damaged	Replace (see chapter 5).
Cylinder head warped	Inspect and replace (see chapter 5).
Valve spring broken or weak	Inspect and replace (see chapter 5).
Valve not seating properly (valve bent , worn or carbon accumulating on the seating surface)	Inspect and repair or replace (see chapter 5).
Knocking:	
Carbon built up in combustion chamber	Repair (see chapter 5).
Fuel poor quality or incorrect (Use the gasoline recommended in the Owner's Manual)	Change fuel (see chapter 3).
Spark plug incorrect	Replace it with the correct plug (see chapter 16).
Stick coil trouble	Inspect (see chapter 16).
IC igniter in ECU trouble	Inspect (see chapter 16).
Inlet air temperature sensor trouble	Inspect (see chapter 3).
Atmospheric pressure sensor trouble	Inspect (see chapter 3).
Miscellaneous:	
Subthrottle sensor trouble	Inspect (see chapter 3).
Subthrottle valve actuator trouble	Inspect (see chapter 3).

DFI System Troubleshooting Guide

Symptoms or Possible Causes	Actions (chapter)
Speed sensor trouble	Inspect (see chapter 3).
Throttle valves won't fully open	Inspect throttle cable and lever linkage (see chapter 3).
Brake dragging	Inspect caliper fluid seal damage or clogging of master cylinder relief and supply ports (see chapter 12).
Clutch slipping	Inspect friction plates for wear (see chapter 6).
Engine overheating-Water temperature sensor, crankshaft sensor or speed sensor trouble	(see Overheating of Troubleshooting Guide in chapter 17).
Engine oil level too high	Repair (see chapter 7).
Engine oil viscosity too high	Change (see chapter 2).
Drive train trouble	Inspect drive chain (see chapter 2) and sprockets (see chapter 11).
Camshaft cam worn	Inspect and replace (see chapter 5).
Air switching valve trouble	Inspect and replace (see chapter 5).
Air suction valve trouble	Inspect and replace (see chapter 5).
Catalytic converters melt down due to muffler overheating (KLEEN)	Replace muffler (see chapter 5).
Exhaust Smokes Excessively:	
(White smokes)	
Piston oil ring worn	Inspect and replace (see chapter 5).
Cylinder worn	Inspect and replace (see chapter 5).
Valve oil seal damaged	Replace (see chapter 5).
Valve guide worn	Replace the guide (see chapter 5).
Engine oil level too high	Repair (see chapter 7).
(Black smoke)	
Air cleaner clogged	Clean (see chapter 3).
Too high fuel pressure	Inspect (see chapter 3) .
Injector stuck open	Inspect (see chapter 3).
Water temperature sensor trouble	Inspect and replace (see chapter 3).
Inlet air temperature sensor trouble	Inspect and replace (see chapter 3).
(Brown smoke)	
Air cleaner duct loose	Reinstall (see chapter 3).
Air cleaner O-ring damaged	Replace (see chapter 3).
Too low fuel pressure	Inspect fuel line and fuel pump (see chapter 3).
Water temperature sensor trouble	Inspect and replace (see chapter 3).
Inlet air temperature sensor trouble	Inspect and replace (see chapter 3)

Self-Diagnosis

The warning indicator light (LED) [A] is used for the FI indicator, immobilizer indicator (immobilizer models) and oil pressure warning indicator.

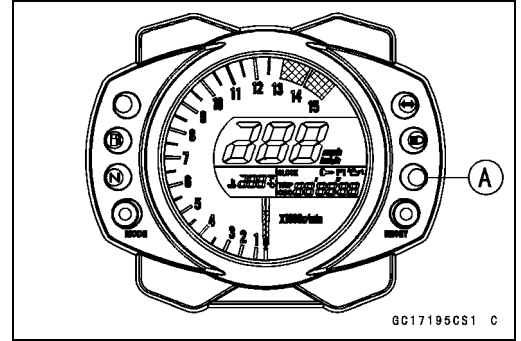

Self-diagnosis Outline

The self-diagnosis system has two modes and can be switched to another mode by operating the meter unit.

User Mode

The ECU notifies the rider of troubles in DFI system, ignition system and immobilizer system by blinking the warning indicator light (LED) [A], FI warning symbol [B] and immobilizer warning symbol [C] when DFI, ignition and immobilizer system parts are faulty, and initiates fail-safe function. In case of serious troubles ECU stops the injection/ignition/starter motor operation.

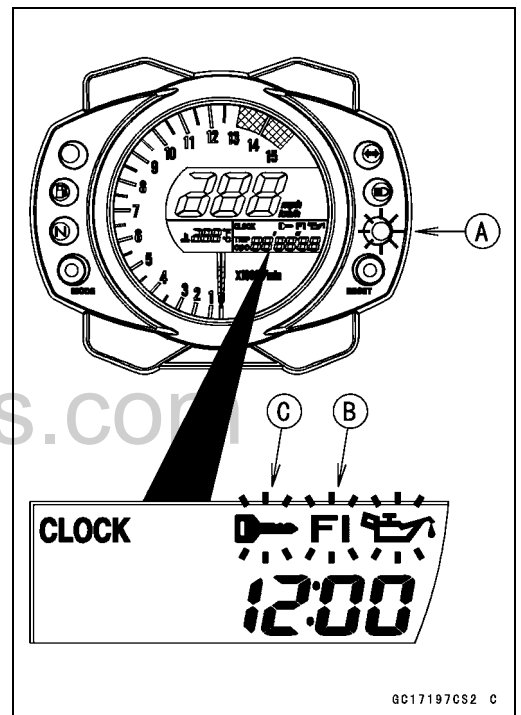

Self-Diagnosis

Dealer Mode

The LCD (Liquid Crystal Display) display the service code(s) [A] to show the problem(s) which the DFI system, ignition system and immobilizer system has at the moment of diagnosis.

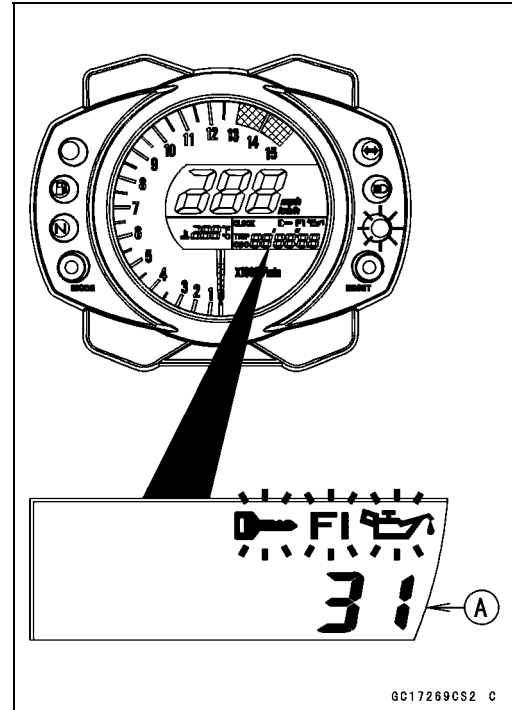

Self-diagnosis Procedures

- When a problem occurs with the DFI system and ignition system, the warning indicator light (LED) [A] and FI warning symbol [B] blinks.
- For models equipped with an immobilizer system, when a problem occurs with the system, the warning indicator light (LED) and immobilizer warning symbol [C] blinks.

NOTE

○Use a fully charged battery when conducting self-diagnosis. Otherwise, the light (LED) and symbol blinks very slowly or do not blink.

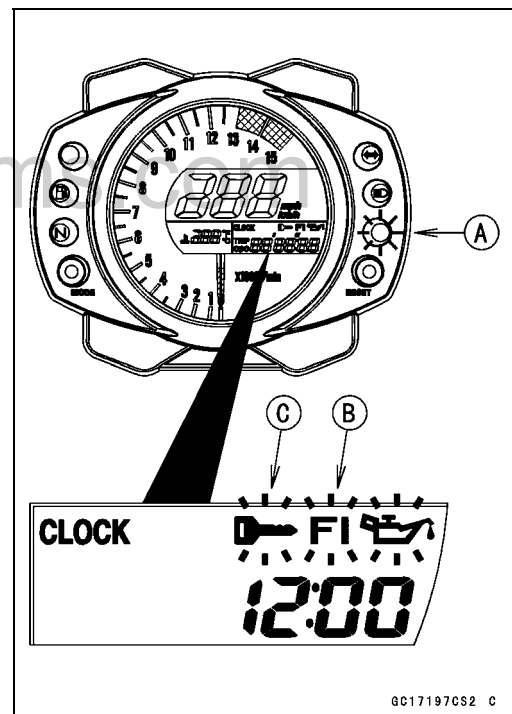

Self-Diagnosis

- Turn the ignition switch ON.
- Push the Mode button [A] to display the odometer.

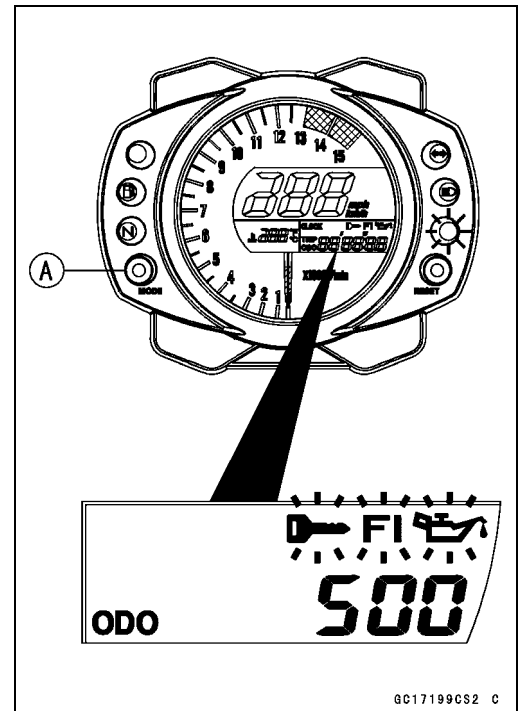

- Push the RESET button [A] for more than two seconds.
 - The service code [B] is displayed on the LCD by the number of two digits.
- After switching to the engine speed setting mode of the shift up indicator light (LED) from odometer display, the service code can not be displayed even if pushing the RESET button for more than two seconds.

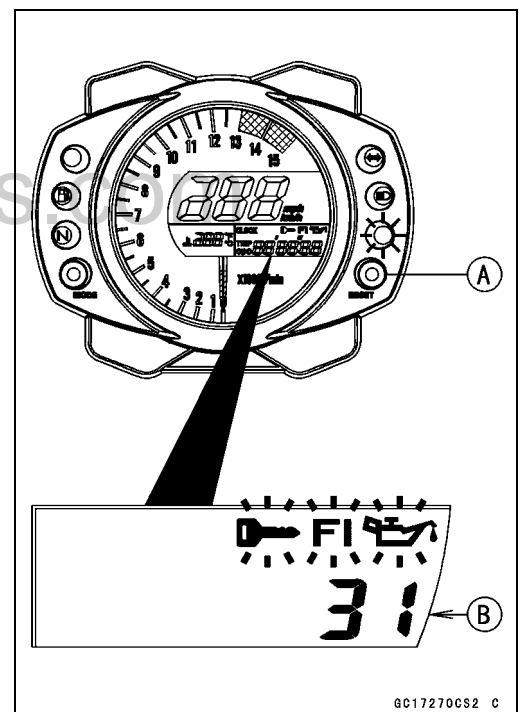

- Any of the following procedures ends self-diagnosis.
- When the service code is displayed on the LCD, push the RESET button for more than two seconds.
- When the ignition switch is turned OFF.

Self-Diagnosis

Self-Diagnosis Flow Chart

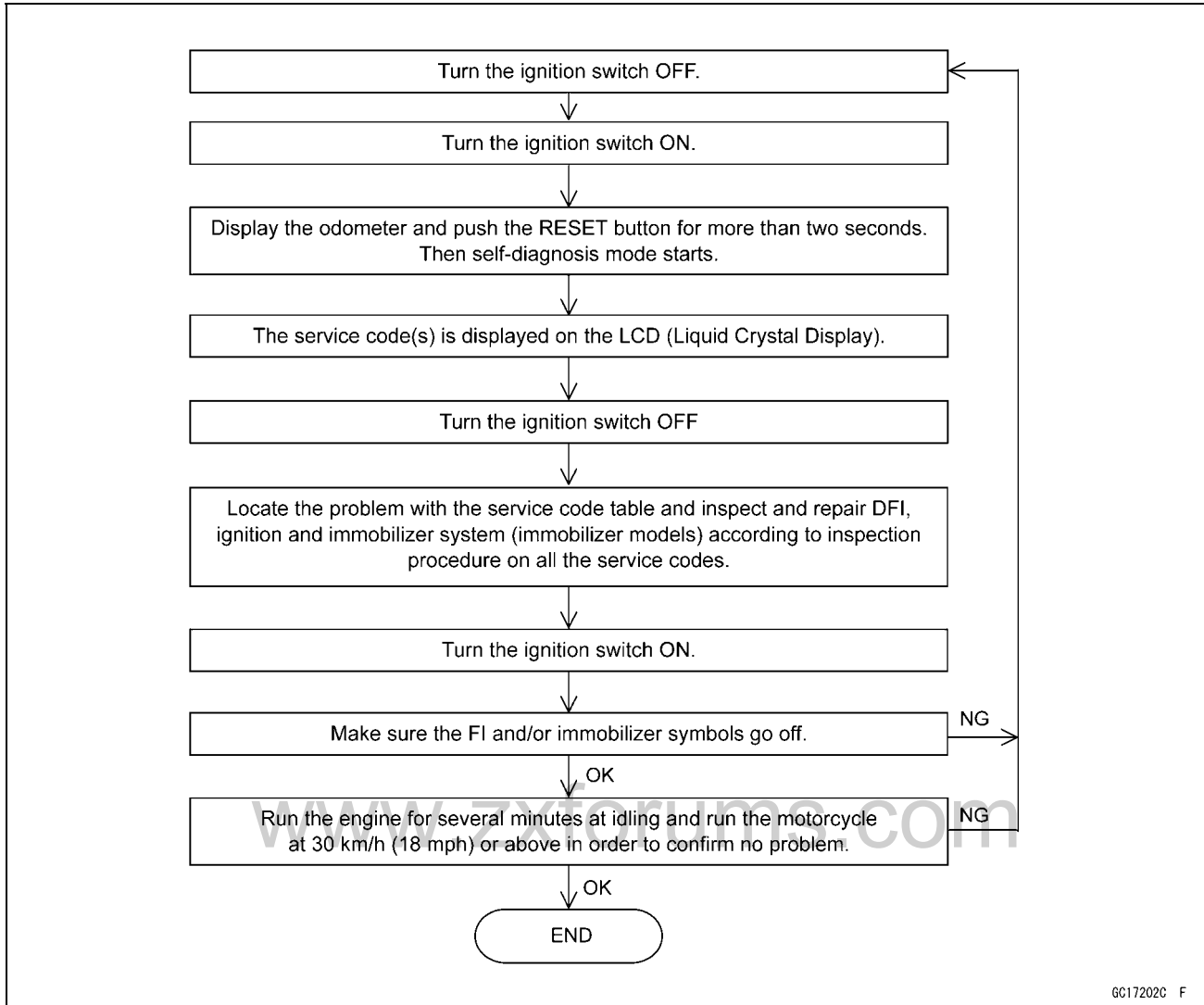

6G17202C F

Self-Diagnosis

Service Code Reading

- The service code(s) is displayed on the LCD by the number of two digits.
- When there are a number of problems, all the service codes can be stored and the display will begin starting from the lowest number service code in the numerical order.
- Then after completing all codes, the display is repeated until the ignition switch is turned OFF or RESET button is pushed for more than two seconds.
- For example, if three problems occurred in the order of 46, 15, 35, the service codes are displayed (each two seconds) from the lowest number in the order listed as shown below.
(15→35→46)→(15→35→46)→···(repeated)

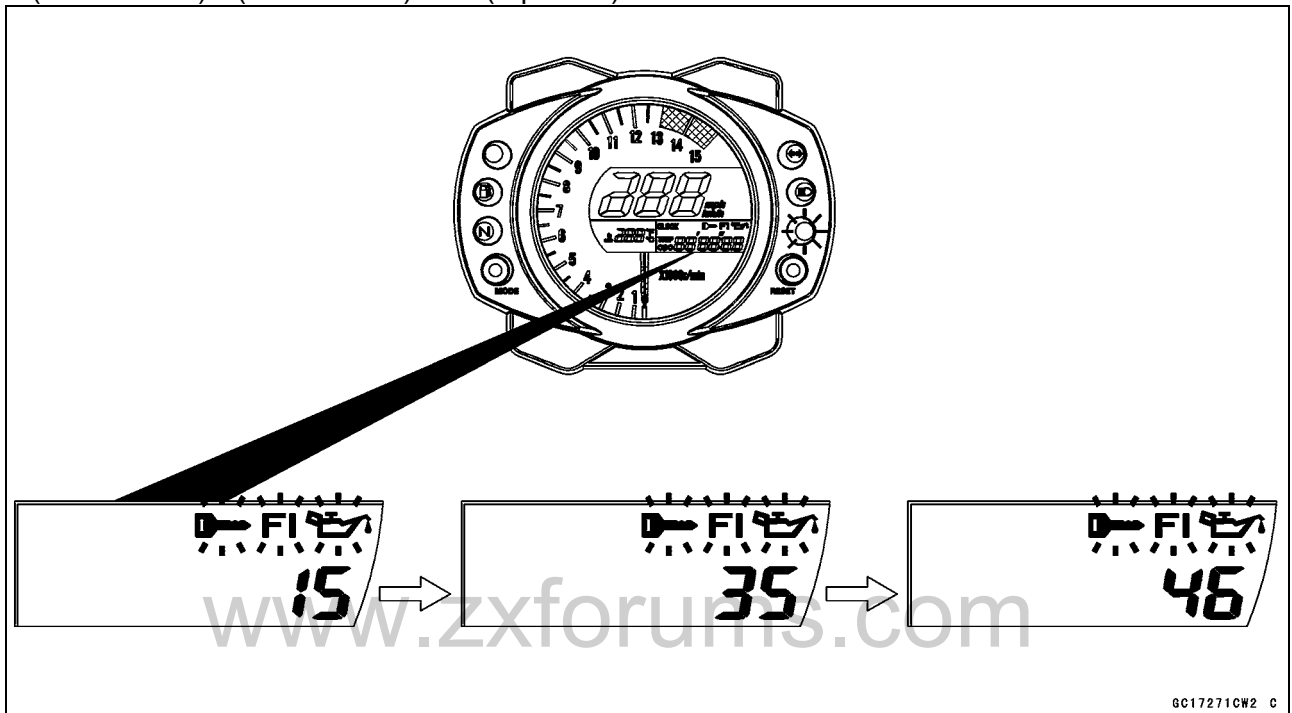

- If there is no problem or when the repair has been done, FI and/or immobilizer symbols go off and no service code is displayed.
- If the problem is with the following parts, the ECU can not memorize these problems, the warning indicator light (LED), FI and/or immobilizer warning symbols do not blinks, and no service codes can be display.
 - Warning Indicator Light (LED)
 - FI and/or Immobilizer Warning Symbols for LCD
 - Stick Coil Secondary Wiring and Ground Wiring (see Stick Coil (Ignition Coil together with Spark Plug Cap) Inspection in the Electrical System chapter)
 - ECU Power Source Wiring and Ground Wiring (see ECU power Supply Inspection)

Service Code Erasing

- When repair has been done, FI and/or immobilizer warning symbols go off and no service code is displayed.
- ★But the service codes stored in memory of the ECU are not erased to preserve the problem history. In this model, the problem history can not be erased.

Self-Diagnosis

Service Code Table

Service Code	Problems
11	Throttle sensor malfunction, wiring open or short
12	Inlet Air Pressure sensor malfunction, wiring open or short
13	Inlet air temperature sensor malfunction, wiring open or short
14	Water temperature sensor malfunction, wiring open or short
15	Atmospheric pressure sensor malfunction, wiring open or short
21	Crankshaft sensor malfunction, wiring open or short
23	Camshaft position sensor malfunction, wiring open or short
24	Speed sensor malfunction
25	Gear position switch malfunction, wiring open or short
31	Vehicle-down sensor malfunction, wiring open or short
32	Subthrottle sensor malfunction, wiring open or short
33	Oxygen sensor #1 inactivation, wiring open or short (Europe Models)
34	Exhaust butterfly valve sensor malfunction, wiring open or short
35	Immobilizer amplifier malfunction
36	Blank key detection
46	Fuel pump relay malfunction, relay is stuck
51	Stick (Ignition) coil #1 malfunction, wiring open or short
52	Stick (Ignition) coil #2 malfunction, wiring open or short
53	Stick (Ignition) coil #3 malfunction, wiring open or short
54	Stick (Ignition) coil #4 malfunction, wiring open or short
62	Subthrottle valve actuator malfunction, wiring open or short
63	Exhaust butterfly valve actuator malfunction, wiring open or short
67	Oxygen sensor heaters (#1 and/or #2) malfunction, wiring open or short (Europe Models)
75	ECU main relay malfunction, relay is stuck
83	Oxygen sensor #2 inactivation, wiring open or short (Europe Models)

Notes:

- The ECU may be involved in these problems. If all the parts and circuits checked out good, be sure to check the ECU for ground and power supply. If the ground and power supply are checked good, replace the ECU.
- When no service code is displayed, the electrical parts of the DFI system has no fault, and the mechanical parts of the DFI system and the engine are suspect.

Self-Diagnosis**Backups**

○The ECU takes the following measures to prevent engine damage when the DFI, ignition or immobilizer system parts have troubles.

Service Codes	Parts	Output Signal Usable Range or Criteria	Backups by ECU
11	Main Throttle Sensor	Main Throttle Sensor Output Voltage 0.2 ~ 4.8 V	If the main throttle sensor system fails (the signal is out of the usable range, wiring short or open), the ECU locks ignition timing into the ignition timing at closed throttle position and sets the DFI in the D-J method.
12	Inlet Air Pressure Sensor	Inlet Air Pressure (absolute) Pv = 100 mmHg ~ 900 mmHg	If the inlet air pressure sensor system fails (the signal Pv is out of the usable range, wiring short or open), the ECU sets the DFI in the α-N method (1).
13	Inlet Air Temperature Sensor	Inlet Air Temperature Ta = - 30°C ~ + 100°C	If the inlet air temperature sensor fails (the signal is out of the usable range, wiring short or open), the ECU sets Ta at 30°C.
14	Water Temperature Sensor	Water Temperature Tw = - 30°C ~ + 120°C	If the water temperature sensor system fails (the signal is out of the usable range, wiring short or open), the ECU sets Tw at 80°C.
15	Atmospheric Pressure Sensor	Absolute Atmospheric Pressure Pa = 100 mmHg ~ 900 mmHg	If the atmospheric pressure sensor system fails (the signal is out of the usable range, wiring short or open), the ECU sets Pa at 760 mmHg (the standard atmospheric pressure).
21	Crankshaft Sensor	Crankshaft sensor cannot send the signal to the ECU during 8 cranks.	If crankshaft sensor fails, the engine stops by itself.
23	Camshaft Position Sensor	Camshaft position sensor cannot send the signal to the ECU during 24 cranks.	If the camshaft position sensor system fails (the signal is missing, wiring short or open), the ECU continues to ignite cylinders in the same sequence following the last good signal.
24	Speed Sensor	Speed sensor must send 4 signals (output signal) to the ECU at the one rotation of the drive shaft.	If the speed sensor system fails (no signal, wiring short or open), the speedometer shows 0.
25	Gear Position Switch	Gear Position Switch Output Voltage (signal) Vg = 0.2 ~ 4.8 V	If the speed sensor system fails (no signal, wiring short or open), the ECU set the top (6) gear position.
31	Vehicle-down Sensor	Vehicle-down Sensor Output Voltage (signal) Vd = 0.2 V ~ 4.8 V	If the vehicle-down sensor system has failures (the output voltage Vd is more than usable range, wiring open), the ECU shuts off the fuel pump, the fuel injectors and the ignition system.
32	Subthrottle Sensor	Subthrottle Sensor Output Voltage 0.2 ~ 4.8 V	If the subthrottle sensor system fails (the signal is out of the usable range, wiring short or open), the actuator locks subthrottle valve at full open position.
33	Oxygen Sensor #1 (Europe Models)	The oxygen sensor #1 is active and sensor must send signals (output voltage) continuously to the ECU.	If the oxygen sensor #1 is not activated, the ECU stops feedback mode of the oxygen sensor #1 and #2.

Self-Diagnosis

Service Codes	Parts	Output Signal Usable Range or Criteria	Backups by ECU
34	Exhaust Butterfly Valve Actuator	Exhaust Butterfly Valve Output Voltage 0.2 ~ 4.8 V	If the exhaust butterfly valve system fails (the signal is out of the usable range, wiring short or open), the actuator locks exhaust butterfly valve at full closed position.
35	Immobilizer Amplifier	-	If the immobilizer system fails (no signal, wiring short or open), the vehicle is no start and run.
36	Master or User Key	The user or master key must use register key.	If the blank key or broken key is used, the vehicle is no start and run.
46	Fuel Pump Relay	When the relay ON condition, battery monitor voltage 5 V or more	If the relay fails, battery monitor voltage 12 V.
51	Stick Coil #1 (Ignition Coil)*	The ignition coil primary winding must send signals (output voltage) 32 or more times continuously to the ECU.	If the ignition primary winding #1 has failures (no signal, wiring short or open), the ECU shuts off the injector #1 to stop fuel to the cylinder #1, though the engine keeps running.
52	Stick Coil #2 (Ignition Coil)*	The ignition coil primary winding must send signals (output voltage) 32 or more times continuously to the ECU.	If the ignition primary winding #2 has failures (no signal, wiring short or open), the ECU shuts off the injector #2 to stop fuel to the cylinder #2, though the engine keeps running.
53	Stick Coil #3 (Ignition Coil)*	The ignition coil primary winding must send signals (output voltage) 32 or more times continuously to the ECU.	If the ignition primary winding #3 has failures (no signal, wiring short or open), the ECU shuts off the injector #3 to stop fuel to the cylinder #3, though the engine keeps running.
54	Stick Coil #4 (Ignition Coil)*	The ignition coil primary winding must send signals (output voltage) 32 or more times continuously to the ECU.	If the ignition primary winding #4 has failures (no signal, wiring short or open), the ECU shuts off the injector #4 to stop fuel to the cylinder #4, though the engine keeps running.
62	Subthrottle Valve Actuator	The actuator operates open and close of the subthrottle valve by the pulse signal from the ECU.	If the subthrottle actuator fails (the signal is out to the usable range, wiring short or open), the ECU stops the current to the actuator.
63	Exhaust Butterfly Valve Actuator	The actuator operates open and close of the exhaust butterfly valve by the pulse signal from the ECU.	If the exhaust butterfly valve actuator fails (the signal is out to the usable range, wiring short or open), the ECU stops the current to the actuator.
67	Oxygen Sensor Heaters (#1 and/or #2) (Europe Models)	The oxygen sensor heaters (#1 and/or #2) raise temperature of the sensor for its earlier activation. 12 V-36 W, 1.5 A × 2	If the oxygen sensor heaters (#1 and/or #2) fails (wiring short or open), the ECU stops the current to the heaters.

Self-Diagnosis

Service Codes	Parts	Output Signal Usable Range or Criteria	Backups by ECU
75	ECU Main Relay	When the relay OFF condition, the main relay is open.	–
83	Oxygen Sensor #2 (Europe Models)	The oxygen sensor #2 is active and sensor must send signals (output voltage) continuously to the ECU.	If the oxygen sensor #2 is not activated, the ECU stops feedback mode of the oxygen sensor #1 and #2.

Note:

(1) α -N Method: the DFI control method from medium to heavy engine load. When the engine load is light like at idling or low speed, the ECU determines the injection quantity by calculating from the throttle vacuum (vacuum sensor output voltage) and engine speed (crankshaft sensor output voltage). This method is called D-J method. As the engine speed increases, and the engine load turns middle to heavy, the ECU determines the injection quantity by calculating from the throttle opening (throttle sensor output voltage) and the engine speed. This method is called α -N method.

* This depends on the number of stopped cylinders.

www.zxforums.com

Main Throttle Sensor (Service Code 11)

The main throttle sensor is a rotating variable resistor that change output voltage according to throttle operating. The ECU senses this voltage change and determines fuel injection quantity, and ignition timing according to engine rpm, and throttle opening.

- Input Terminal [A]
- Output Terminal [B]
- Ground Terminal [C]

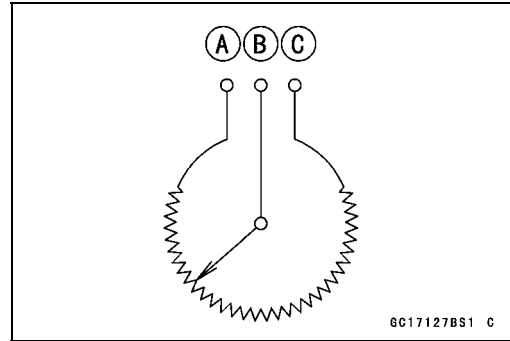

Main Throttle Sensor Removal/Adjustment

CAUTION

Do not remove or adjust the main throttle sensor since it has been adjusted and set with precision at the factory.

Never drop the throttle body assy, especially on a hard surface. Such a shock to the sensor can damage it.

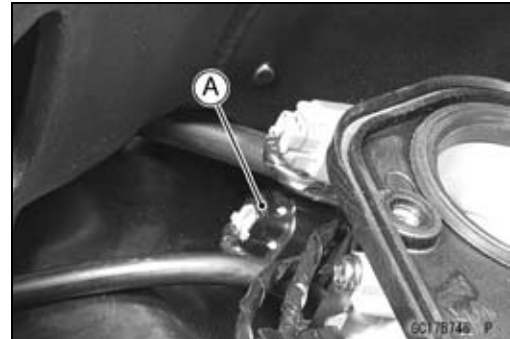

Main Throttle Sensor Connector [A]

Input Voltage Inspection

NOTE

○Be sure the battery is fully charged.

- Turn the ignition switch OFF.
- Remove the ECU (see ECU Removal).
- Do not disconnect the ECU connectors.

- Connect a digital meter [A] to the connectors [B], using the needle adapter set.

Special Tool - Needle Adapter Set: 57001-1457

Main Throttle Sensor Input Voltage Connections to ECU Connector

- Meter (+) → BL lead (terminal 7)
- Meter (-) → BR/BK lead (terminal 34)

- Measure the input voltage with the engine stopped, and with the connectors joined.
- Turn the ignition switch ON.

Input Voltage at ECU Connector

Standard: DC 4.75 ~ 5.25 V

- Turn the ignition switch OFF.
- ★ If the reading of input voltage is less than the standard, check the ECU for its ground, and power supply (see ECU Power Supply Inspection) and wiring shorted. If the input voltage is within the standard range, check the input voltage at the main throttle sensor connector.

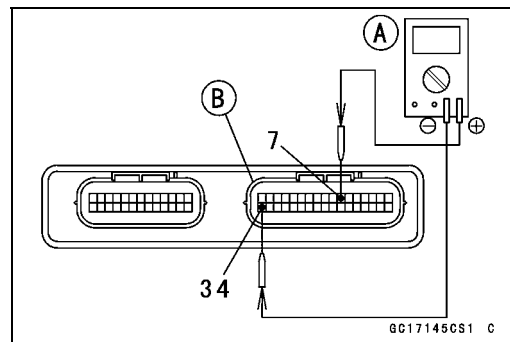

Main Throttle Sensor (Service Code 11)

- Remove the throttle body assy temporarily (see Throttle Body Assy Removal).
- Disconnect the main throttle sensor connector [A].

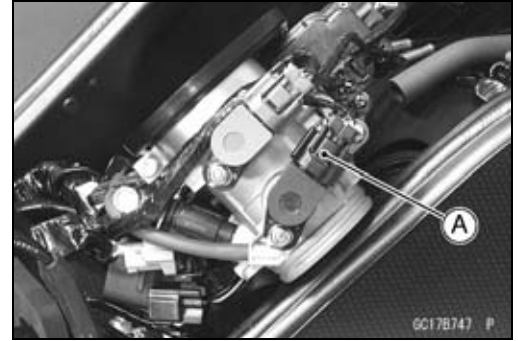

- Connect the harness adapter [A] between the harness connector and main throttle sensor connector.
- Connect a digital meter to the harness adapter leads.

Special Tool - Throttle Sensor Setting Adapter: 57001-1538

Main Throttle Sensor Input Voltage Connections to Adapter

Meter (+) → W (sensor BL) lead

Meter (-) → BK (sensor BR/BK) lead

- Reinstall the throttle body assy (See Throttle Body Assy Installation).
- Measure the input voltage with the engine stopped, and with the connector joined.
- Turn the ignition switch ON.

Input Voltage at Sensor

Standard: DC 4.75 ~ 5.25 V

- Turn the ignition switch OFF.
- ★ If the reading is out of the range, check the wiring (see wiring diagram in this section).
- ★ If the reading is good, check the output voltage of the sensor.

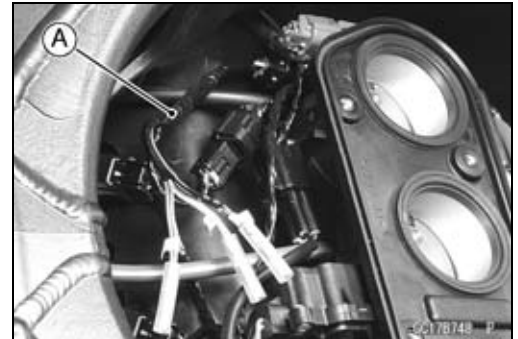

Main Throttle Sensor (Service Code 11)**Output Voltage Inspection**

- Measure the output voltage at the ECU in the same way as input voltage inspection. Note the following.

Digital Meter [A]

Connector [B]

Special Tool - Needle Adapter Set: 57001-1457

Main Throttle Sensor Output Voltage**Connections to ECU Connector**

Meter (+) → Y/W lead (terminal 26)

Meter (-) → BR/BK lead (terminal 34)

- Start the engine and warm it up thoroughly.
- Check idle speed to ensure throttle opening is correct.

Idle Speed

Standard: 1 100 r/min (rpm)

- ★ If the idle speed is out of the specified range, adjust the idle speed (see Idle Speed Inspection in Periodic Maintenance chapter).
- Turn the ignition switch OFF.
- Measure the output voltage with the engine stopped, and with the connector joined.
- Turn the ignition switch ON.
- Measure the output voltage when the throttle is fully opened or completely closed.

Output Voltage at ECU

Standard: DC 0.65 ~ 3.90 V (at idle throttle opening to full throttle opening)

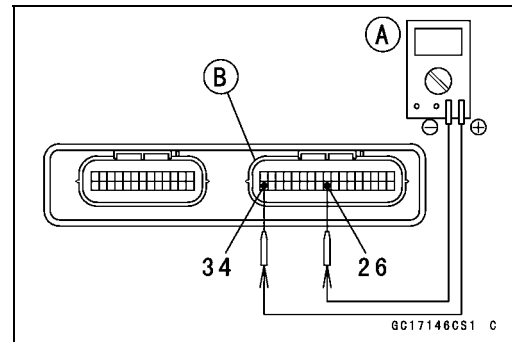
**NOTE**

- The throttle sensor is operating correctly if the following voltages are obtained:
 - DC 0.65 V (or slightly higher) with the throttle at the idle position.
 - DC 3.90 V (or slightly lower) with the throttle at the fully open position.

CAUTION

Do not remove or adjust the main throttle sensor. It has been adjusted and set with precision at the factory.

Never drop the sensor can especially on a hard surface. A shock to the sensor can damage it.

Main Throttle Sensor (Service Code 11)

NOTE

○ *The standard voltage refers to the value when the voltage reading at the Input Voltage Inspection shows 5V exactly.*

○ *When the input voltage reading shows other than 5V, derive a voltage range as follows.*

Example:

In the case of a input voltage of 4.75 V.

$$0.65 \times 4.75 \div 5.00 = 0.62 \text{ V}$$

$$3.90 \times 4.75 \div 5.00 = 3.71 \text{ V}$$

Thus, the valid range is 0.62 ~ 3.71 V

- ★ If the output voltage is within the standard range, check the ECU for its ground, and power supply (see ECU Power Supply Inspection). If the ground and power supply are good, replace the ECU (see ECU section).
- ★ If the output voltage is far out of the standard range (e.g. when the wiring is open, the reading is 0 V), check the output voltage again at the sensor connector.

www.zxforums.com

Main Throttle Sensor (Service Code 11)

- Disconnect the main throttle sensor connector and connect the harness adapter [A] between the harness connector and main throttle sensor connector.

Special Tool - Throttle Sensor Setting Adapter: 57001-1538

- Connect a digital meter to the harness adapter leads.

**Throttle Sensor Output Voltage
Connections to Adapter**

Meter (+) → R (sensor Y/W) lead

Meter (-) → BK (sensor BR/BK) lead

- Measure the sensor output voltage with the engine stopped, and with the connector joined.
- Turn the ignition switch ON.
- Measure the output voltage when the throttle is fully opened or completely closed.

Output Voltage at Sensor

Standard: DC 0.65 ~ 3.90 V (at idle throttle opening to full throttle opening)

NOTE

○ *The throttle sensor is operating correctly if the following voltages are obtained:*

- DC 0.65 V (or slightly higher) with the throttle at the idle position.
- DC 3.90 V (or slightly lower) with the throttle at the fully open position.

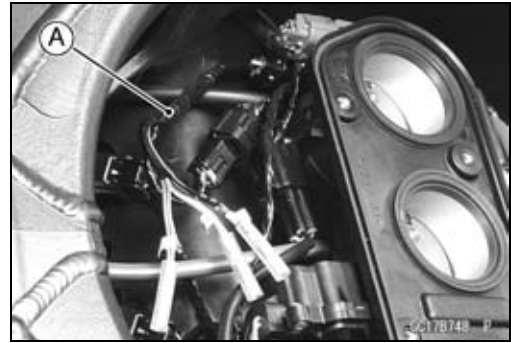

CAUTION

Do not remove or adjust the main throttle sensor. It has been adjusted and set with precision at the factory. Never drop the sensor, especially on a hard surface. A shock to the sensor can damage it.

NOTE

○ *The standard voltage refers to the value when the voltage reading at the Input Voltage Inspection shows 5V exactly.*

○ *When the input voltage reading shows other than 5V, derive a voltage range as follows.*

Example:

In the case of a input voltage of 4.75 V.

$$0.65 \times 4.75 \div 5.00 = 0.62 \text{ V}$$

$$3.90 \times 4.75 \div 5.00 = 3.71 \text{ V}$$

Thus, the valid range is 0.62 ~ 3.71 V

- After main throttle sensor voltage inspection, remove the harness adapter.
- ★ If the reading is out of the standard range, inspect the main throttle sensor resistance.
- ★ If the output voltage is normal, check the wiring for continuity (see wiring diagram in this section).

Main Throttle Sensor (Service Code 11)

Resistance Inspection

- Turn the ignition switch OFF.
- Disconnect the main throttle sensor connector.
- Connect a digital meter [A] to the main throttle sensor connector [B].
- Measure the main throttle sensor resistance.

Main Throttle Sensor Resistance

Connections: BL lead [C] ↔ BR/BK lead [D]

Standard: 4 ~ 6 kΩ

- ★ If the reading is out of the range, replace the throttle body assy (see Throttle Body Assy section).
- ★ If the reading is within the range, but the problem still exists, replace the ECU (see ECU section).

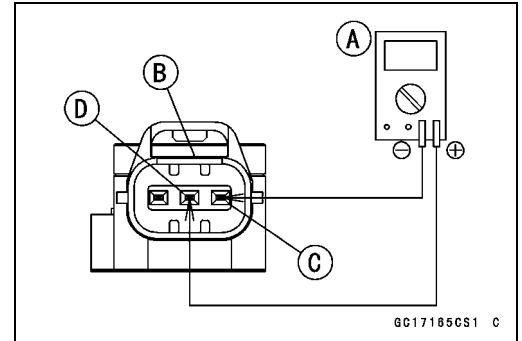

Main Throttle Sensor Circuit

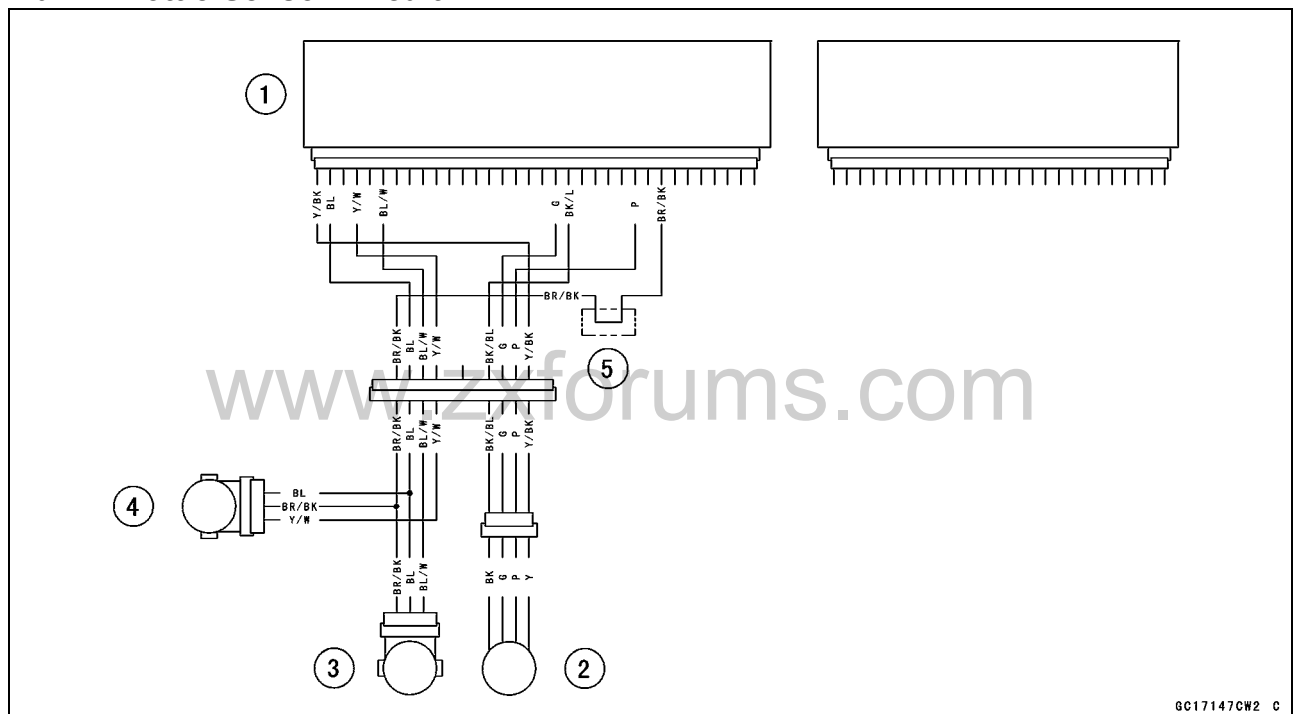

1. ECU
2. Subthrottle Valve Actuator
3. Subthrottle Sensor
4. Main Throttle Sensor
5. Water-proof Joint 2

Inlet Air Pressure Sensor (Service Code 12)

CAUTION

Never drop the sensor, especially on a hard surface. Such a shock to the part can damage it.

Removal

- Turn the ignition switch OFF.
- Remove:
 - Air Cleaner Housing (see Air Cleaner Housing Removal)
 - Inlet Air Pressure Sensor Connector [A]
 - Inlet Air Pressure Sensor [B]
 - Vacuum Hose

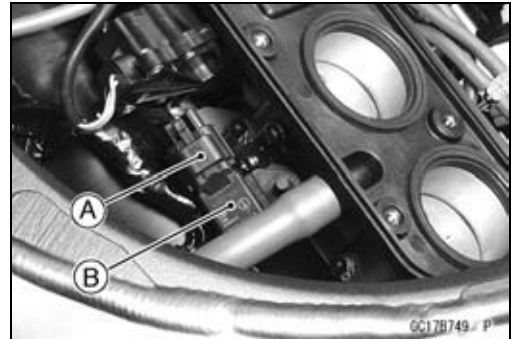

Installation

NOTE

○ The inlet air pressure sensor is the same part as the atmospheric sensor except that the sensor has a vacuum hose and different wiring.

- Install the vacuum hose.
- Put the inlet air pressure sensor in the stay plate [A] of throttle body assy.

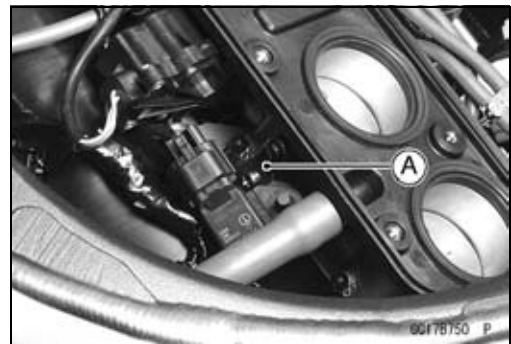

Input Voltage Inspection

NOTE

○ Be sure the battery is fully charged.
 ○ The inspection is the same as "Input Voltage Inspection" of the throttle sensor and the atmospheric pressure sensor.

- Turn the ignition switch OFF.
- Remove the ECU (see ECU Removal).
- Do not disconnect the ECU connectors.
- Connect a digital meter [A] to the connector [B], with the needle adapter set.

Special Tool - Needle Adapter Set: 57001-1457

Inlet Air Pressure Sensor Input Voltage Connections to ECU Connector

- Meter (+) → BL lead (terminal 7)
- Meter (-) → BR/BK lead (terminal 34)

- Measure the input voltage with the engine stopped, and with the connectors joined.
- Turn the ignition switch ON.

Input Voltage at ECU

Standard: DC 4.75 ~ 5.25 V

- ★ If the reading is less than the standard range, check the ECU for its ground, and power supply (see ECU Power Supply Inspection). If the ground and power supply are good, replace the ECU (see ECU section).

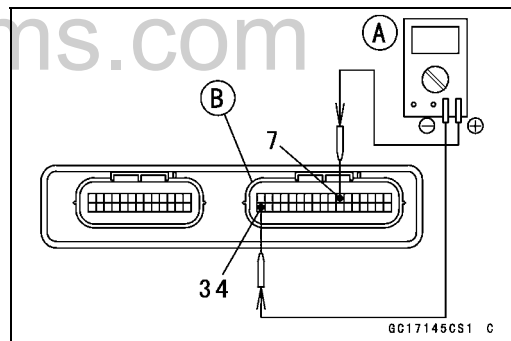

Inlet Air Pressure Sensor (Service Code 12)

★ If the reading is within the standard range, and check the input voltage again at the sensor connector.

- Remove the air cleaner housing (see Air Cleaner Housing Removal).
- Disconnect the inlet air pressure sensor connector and connect the harness adapter [A] between the harness connector and inlet air pressure sensor connector.

Special Tool - Sensor Harness Adapter: 57001-1561

- Connect a digital meter to the harness adapter leads. Inlet Air Pressure Sensor [B]

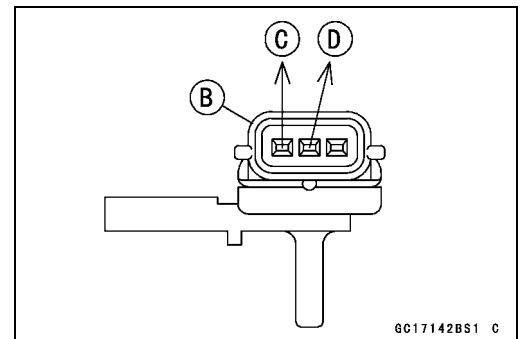
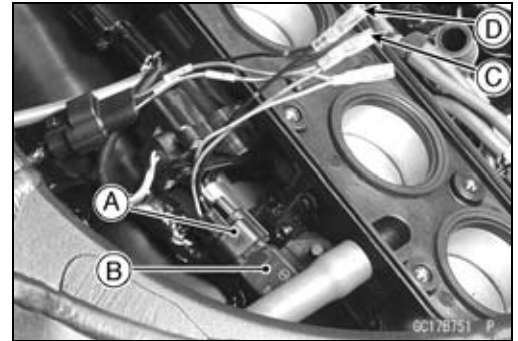

Inlet Air Pressure Sensor Input Voltage

Connections to Adapter

Meter (+) → G (sensor BL) lead [C]

Meter (-) → BK (sensor BR/BK) lead [D]

- Measure the input voltage with the engine stopped.
- Turn the ignition switch ON.

Input Voltage at Sensor Connector

Standard: DC 4.75 ~ 5.25 V

★ If the reading is out of the standard range, check the wiring (see wiring diagram in this section).

★ If the reading is good, the input voltage is normal. Check the output voltage.

- Turn the ignition switch OFF.

Output Voltage Inspection

- Measure the output voltage at the ECU in the same way as input voltage inspection. Note the following.

Digital Meter [A]

Connector [B]

Special Tool - Needle Adapter Set: 57001-1457

Inlet Air Pressure Sensor Output Voltage

Connections to ECU

Meter (+) → Y/BL lead (terminal 28)

Meter (-) → BR/BK lead (terminal 34)

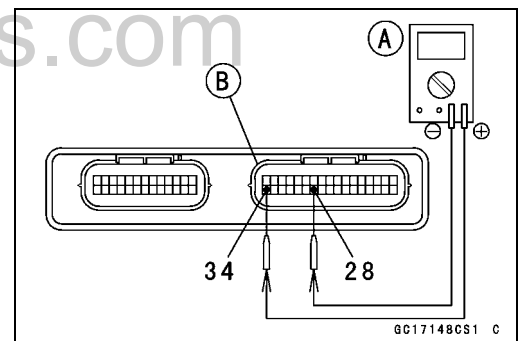

Output Voltage at ECU

Usable Range: DC 3.80 ~ 4.20 V at the standard atmospheric pressure (101.32 kPa, 76 cmHg abs.)

NOTE

- The output voltage changes according to the local atmospheric pressure.
- The vacuum sensor output voltage is based on a nearly perfect vacuum in the small chamber of the sensor. So, the sensor indicates absolute vacuum pressure.

★ If the output voltage is within the usable range, check the ECU for its ground, and power supply (see ECU Power Supply Inspection). If the ground and power supply are good, replace the ECU (see ECU section).

Inlet Air Pressure Sensor (Service Code 12)

★ If the output voltage is far out of the usable range, check the output voltage again at the sensor connector [A] (when the lead is open, the output voltage is about 1.8 V).

- Connect a digital meter to the harness adapter leads. Inlet Air Pressure Sensor [B]

Special Tool - Sensor Harness Adapter: 57001-1561

Inlet Air Pressure Sensor Output Voltage Connections to Adapter

Meter (+) → G/W (sensor Y/BL) lead [C]

Meter (-) → BK (sensor BR/BK) lead [D]

Output Voltage at Sensor Connector

Usable Range: DC 3.80 ~ 4.20 V at the standard atmospheric pressure (101.32 kPa or 76 cmHg abs.)

★ If the output voltage is normal, check the wiring for continuity (see wiring diagram in this section).

★ If the output voltage is out of the usable range, replace the sensor.

- Turn the ignition switch OFF.
- Remove the harness adapter.

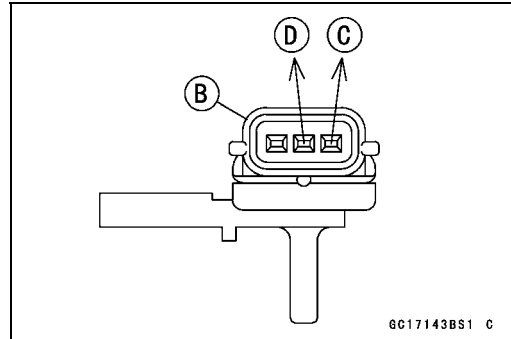
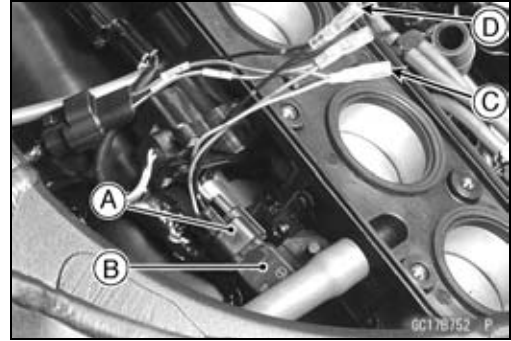

Inlet Air Pressure Sensor Circuit

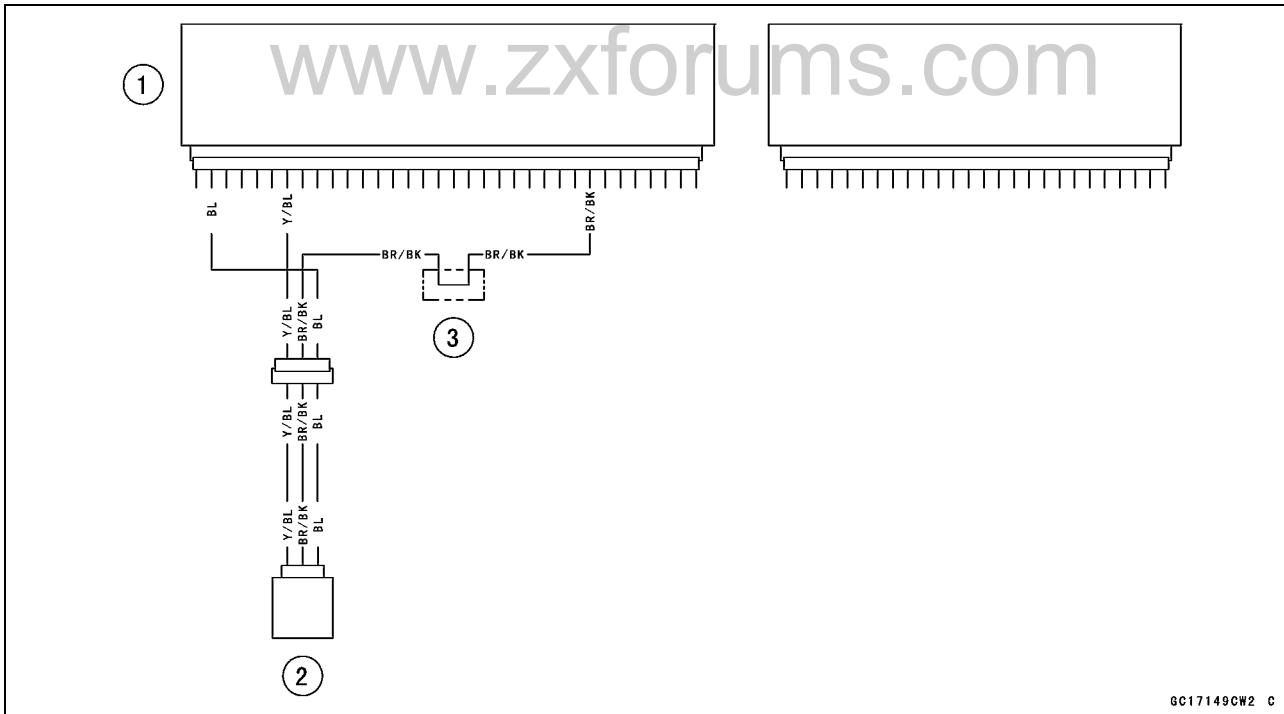

1. ECU
2. Inlet Air Pressure Sensor
3. Water-proof Joint 2

★ If you need to check the inlet air pressure sensor for vacuum other than 76 cmHg (abs.), check the output voltage as follows.

Inlet Air Pressure Sensor (Service Code 12)

- Remove the inlet air pressure sensor [A] and disconnect the vacuum hose from the sensor.
- Connect an auxiliary hose [B] to the inlet air pressure sensor.
- Temporarily install the inlet air pressure sensor.
- Connect a digital meter [C], vacuum gauge [D], and the fork oil level gauge [E] to the inlet air pressure sensor.

Special Tools - Fork Oil Level Gauge: 57001-1290

Vacuum Gauge: 57001-1369

Sensor Harness Adapter: 57001-1561

Inlet Air Pressure Sensor Output Voltage Connection to Adapter

Meter (+) → G/W (sensor Y/BL) lead

Meter (-) → BK (sensor BR/BK) lead

- Turn the ignition switch ON.
- Measure the inlet air pressure sensor output voltage from various vacuum readings, while pulling the handle of the fork oil level gauge.
- Check the inlet air pressure sensor output voltage, using the following formula and chart.

Suppose:

Pg : Vacuum Pressure (gauge) of Throttle Assy

PI : Local Atmospheric Pressure (abs.) measured by a barometer

Pv : Vacuum Pressure (abs.) of Throttle Assy

Vv : Sensor Output Voltage (v)

then

$$Pv = PI - Pg$$

For example, suppose the following data is obtained:

Pg = 8 cmHg (vacuum gauge reading)

PI = 70 cmHg (barometer reading)

Vv = 3.2 V (digital volt meter reading)

then

$$Pv = 70 - 8 = 62 \text{ cmHg (abs.)}$$

Plot this Pv (62 cmHg) at a point [1] on the chart and draw a vertical line through the point. Then, you can get the usable range [2] of the sensor output voltage.

Usable range = 3.08 ~ 3.48 V

Plot Vv (3.2 V) on the vertical line. → Point [3].

Results: In the chart, Vv is within the usable range and the sensor is normal.

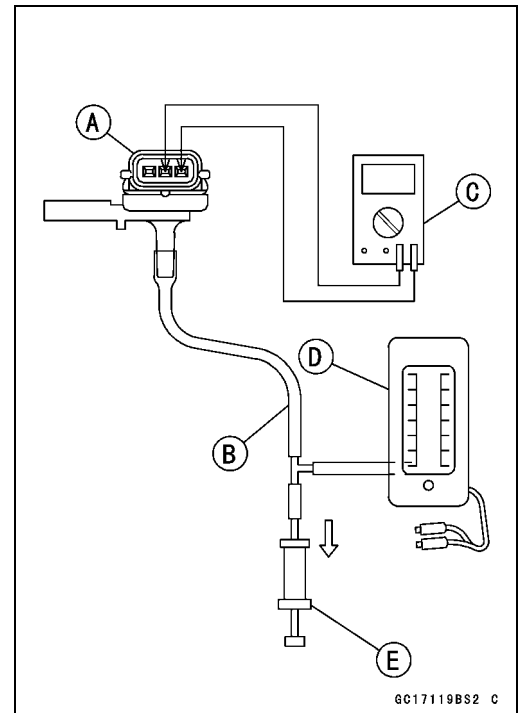

Inlet Air Pressure Sensor (Service Code 12)

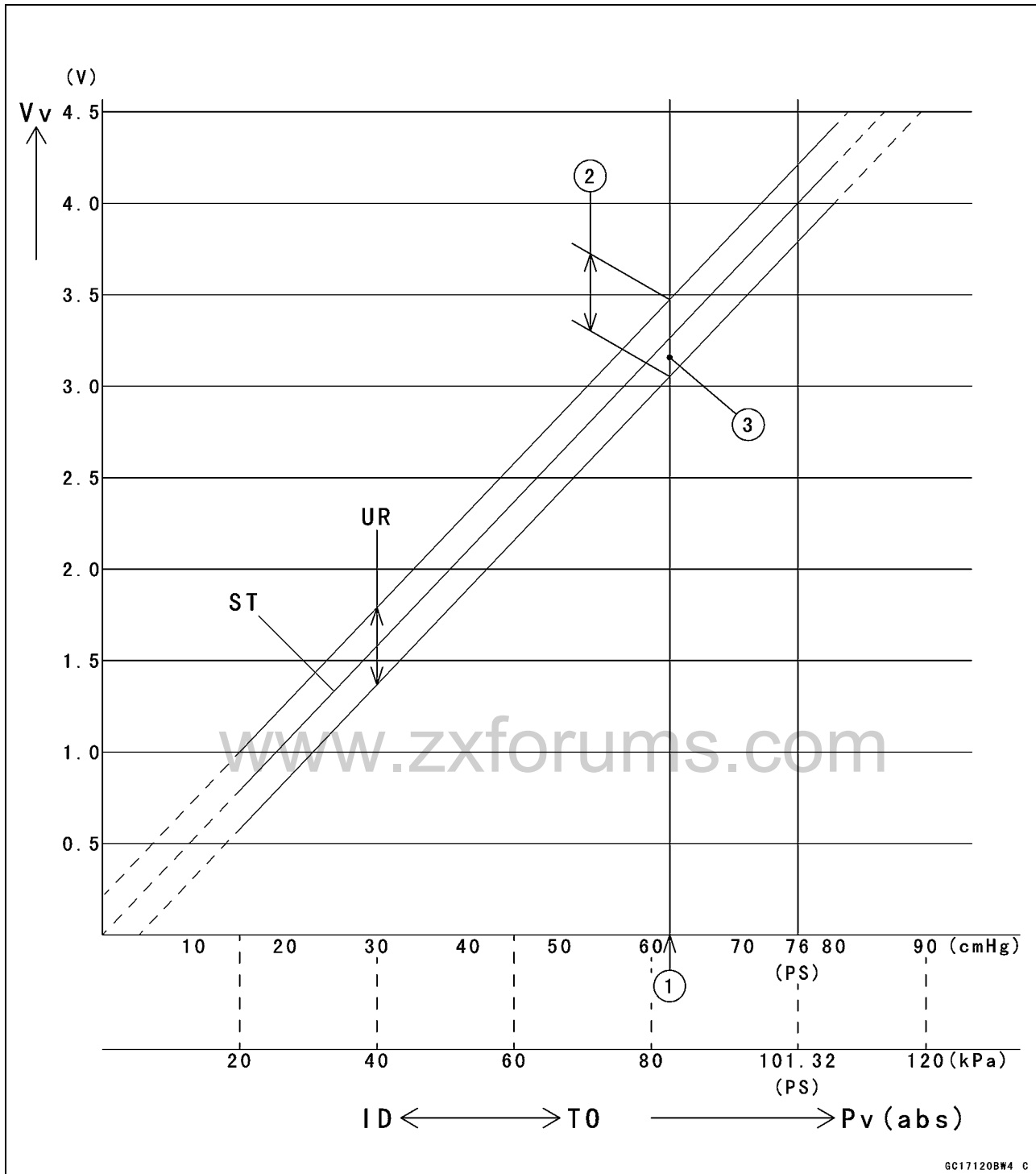

GC17120BW4 C

- ID: Idling
- Pv: Throttle Vacuum Pressure (abs.)
- Ps: Standard Atmospheric Pressure (abs.)
- ST: Standard of Sensor Output Voltage (v)
- TO: Throttle Full Open
- UR: Usable Range of Sensor Output Voltage (v)
- Vv: Inlet Air Pressure Sensor Output Voltage (V) (Digital Meter Reading)

Inlet Air Temperature Sensor (Service Code 13)**Removal/Installation****CAUTION**

Never drop the sensor, especially on a hard surface. Such a shock to the sensor can damage it.

- Remove the fuel tank (see Fuel Tank Removal).
 - Disconnect the connector [A] from the inlet air temperature sensor.
 - Pull out the inlet air temperature sensor [B].
-
- Install the inlet air temperature sensor [A] in the grommet [B].

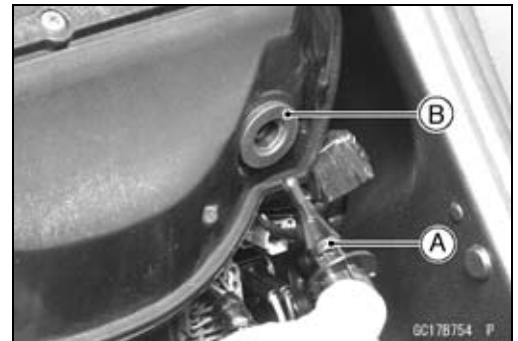
**Output Voltage Inspection****NOTE**

○ Be sure the battery is fully charged.

- Remove the ECU (see ECU Removal).
- Do not disconnect the ECU connectors.
- Connect a digital meter to the ECU connector, using needle adapter set.

Special Tool - Needle Adapter Set: 57001-1457

**Inlet Air Temperature Sensor Output Voltage
Connections to ECU Connector**

Meter (+) → Y lead (terminal 8)

Meter (-) → BR/BK lead (terminal 34)

- Measure the sensor output voltage with the engine stopped and the connector joined.
- Turn the ignition switch ON.

Output Voltage at ECU

Standard: About 2.25 ~ 2.50 V at inlet air temperature 20°C (68°F)

NOTE

○ The output voltage changes according to the inlet air temperature.

- Turn the ignition switch OFF.

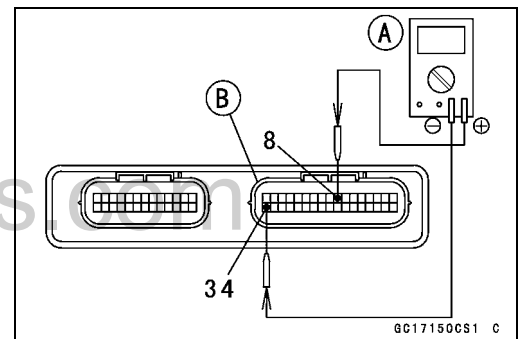

Inlet Air Temperature Sensor (Service Code 13)

- ★ If the output voltage is out of the specified, check the ECU for its ground, and power supply (see ECU Power Supply Inspection). If the ground and power supply are good, replace the ECU (see ECU section).
- ★ If the output voltage is far out of the specified (e.g. when the wiring is open, the voltage is about 4.6 V), check the wiring (see wiring diagram in this section).
- Remove the needle adapter set, and apply silicone sealant to the seals of the ECU connector for waterproofing.

Sealant - Kawasaki Bond (Silicone Sealant): 56019-120

- ★ If the wiring is good, check the sensor resistance.

Sensor Resistance Inspection

- Remove the inlet air temperature sensor (see Removal/Installation).
- Suspend the sensor [A] in a container of machine oil so that the heat-sensitive portion is submerged.
- Suspend a thermometer [B] with the heat-sensitive portion [C] located in almost the same depth with the sensor.

NOTE

○ The sensor and thermometer must not touch the container side or bottom.

- Place the container over a source of heat and gradually raise the temperature of the oil while stirring the oil gently for even temperature.
- Using a digital meter, measure the internal resistance of the sensor across the terminals at the temperatures shown in the table.

Inlet Air Temperature Sensor Resistance

Standard: 2.09 ~ 2.81 k Ω at 20°C (68°F)

About 0.322 k Ω at 80°C (176°F) (reference value)

- ★ If the measurement is out of the range, replace the sensor.
- ★ If the measurement is within the specified, replace the ECU (see ECU section).

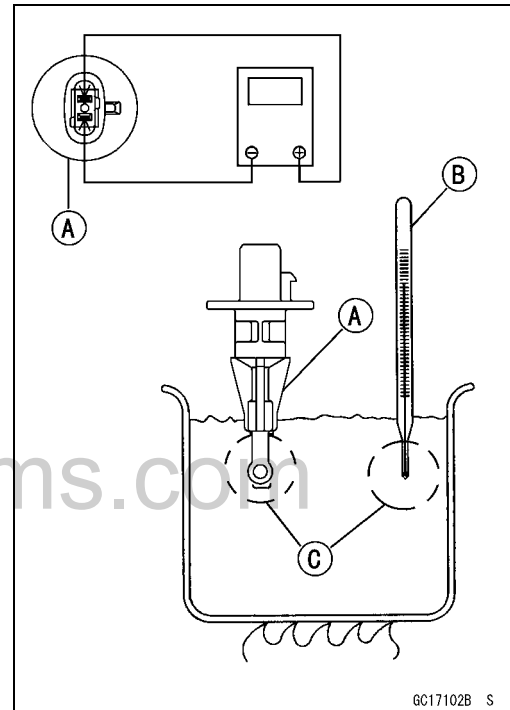

GC17102B S

Inlet Air Temperature Sensor (Service Code 13)

Inlet Air Temperature Sensor Circuit

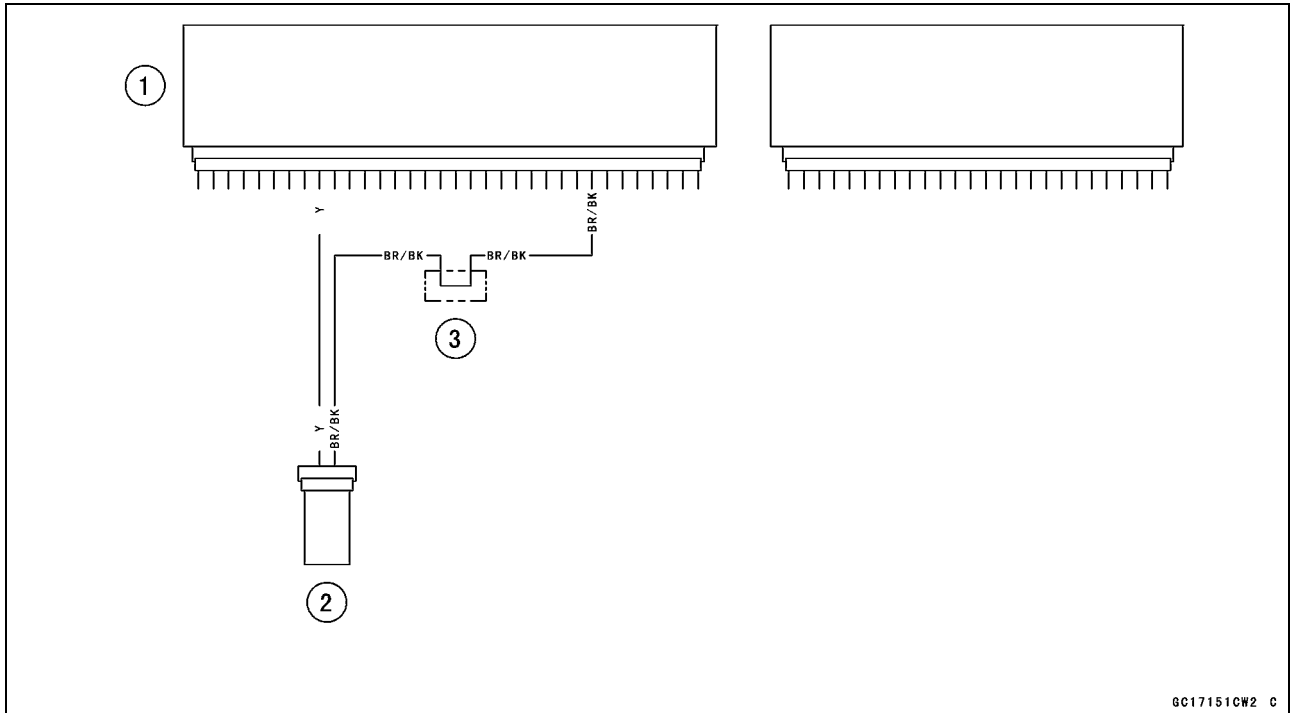

- 1. ECU
- 2. Inlet Air Temperature Sensor
- 3. Water-proof Joint 2

www.zxforums.com

Water Temperature Sensor (Service Code 14)

Removal/Installation

CAUTION

Never drop the sensor, especially on a hard surface. Such a shock to the sensor can damage it.

- Drain the coolant (see Coolant Change in the Periodic Maintenance chapter).
- Remove:
 - Air Cleaner Housing (see Air Cleaner Housing Removal)
 - Throttle Body Assy (see Throttle Body Assy Removal)
 - Connector [A]
 - Water Temperature Sensor [B]
- Apply silicone sealant to the threads of the water temperature sensor and tighten it.

Sealant - Kawasaki Bond (Silicone Sealant): 92104-0004

Torque - Water Temperature Sensor: 25 N·m (2.5 kgf·m, 18 ft·lb)
- Fill the engine with coolant and bleed the air from the cooling system (see Coolant Filling in the Cooling System chapter).

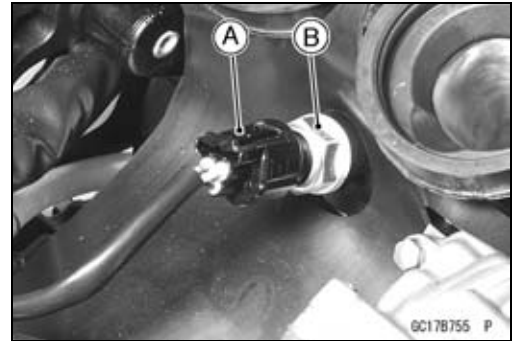

Output Voltage Inspection

NOTE

○Be sure the battery is fully charged.

- Remove the ECU (see ECU Removal).
- Do not disconnect the ECU connectors.
- Connect a digital meter [A] to the ECU connectors [B], with the needle adapter set.

Special Tool - Needle Adapter Set: 57001-1457

Water Temperature Sensor Output Voltage Connections to ECU

Meter (+) → O lead (terminal 25)

Meter (-) → BR/BK lead (terminal 34)

- Measure the sensor output voltage with the engine stopped and the connector joined.
- Turn the ignition switch ON.

Output Voltage at ECU

Standard: About 2.80 ~ 2.97 V at 20°C (68°F)

NOTE

○The output voltage changes according to the coolant temperature in the engine.

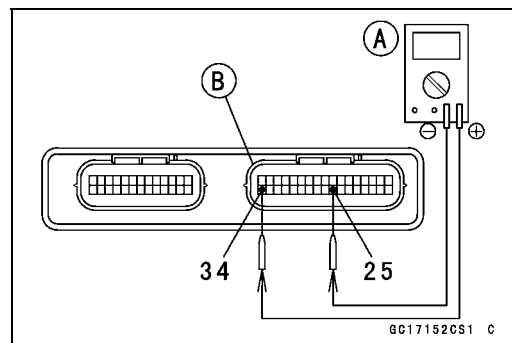

Water Temperature Sensor (Service Code 14)

- Turn the ignition switch OFF.
- ★ If the output voltage is out of the specified, check the ECU for its ground, and power supply (see ECU Power Supply Inspection). If the ground and power supply are good, replace the ECU (see ECU section).
- ★ If the output voltage is far out of the specified (e.g. when the wiring is open, the voltage is about 5V), check the wiring (see wiring diagram in this section).
- ★ If the wiring is good, check the water temperature sensor resistance.
- Remove the needle adapter set, and apply silicone sealant to the seals of the ECU connector for waterproofing.

Sealant - Kawasaki Bond (Silicone Sealant): 56019-120

Sensor Resistance Inspection

- Refer to the Water Temperature Sensor Inspection in the Electrical System chapter (see Water Temperature Sensor Inspection in the Electrical System chapter).

Water Temperature Sensor Circuit

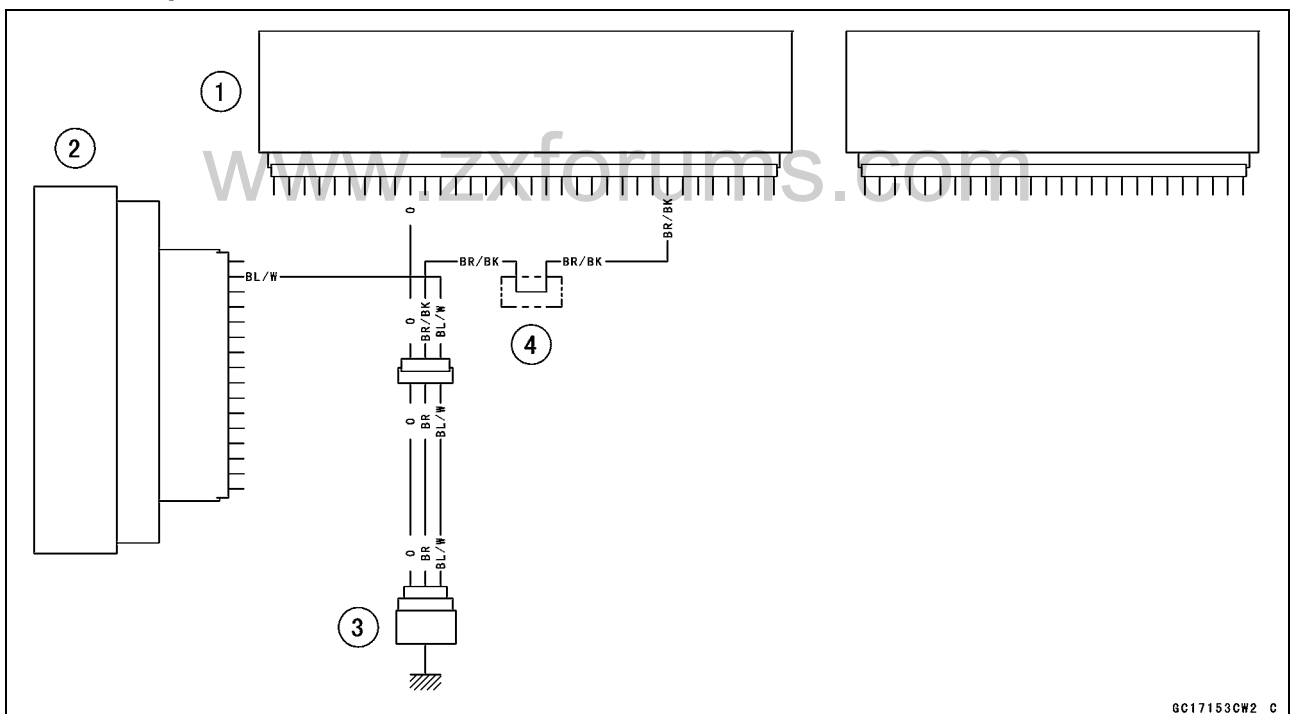

1. ECU
2. Meter Unit
3. Water Temperature Sensor
4. Water-proof Joint 2

Atmospheric Pressure Sensor (Service Code 15)**CAUTION**

**Never drop the sensor, especially on a hard surface.
Such a shock to the sensor can damage it.**

Removal

- Turn the ignition switch OFF.
- Remove:
 - Seat Cover (see Seat Cover Removal in the Frame chapter)
 - Atmospheric Pressure Sensor Connector [A]
 - Damper [B]
 - Atmospheric Pressure Sensor [C]

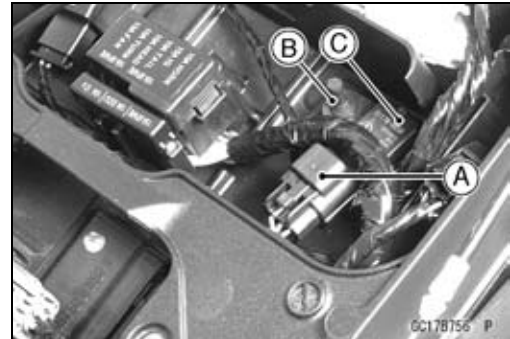
**Installation****NOTE**

○ The atmospheric pressure sensor is the same part as the inlet air pressure sensor except that the inlet air pressure sensor has a inlet air pressure hose and different wiring.

- Installation is reverse of removal.

Input Voltage Inspection**NOTE**

○ Be sure the battery is fully charged.
○ The inspection is the same as "Input Voltage Inspection" of the throttle sensor and the inlet air pressure sensor.

- Turn the ignition switch OFF.
- Remove the ECU (see ECU Removal).
- Do not disconnect the ECU connectors.
- Connect a digital meter [A] to the connector [B], with the needle adapter set.

Special Tool - Needle Adapter Set: 57001-1457

**Atmospheric Pressure Sensor Input Voltage
Connections to ECU Connector**

Meter (+) → BL lead (terminal 7)

Meter (-) → BR/BK lead (terminal 34)

- Measure the input voltage with the engine stopped, and with the connectors joined.
- Turn the ignition switch ON.

Input Voltage at ECU

Standard: DC 4.75 ~ 5.25 V

- ★ If the reading of input voltage is less than the standard range, check the ECU for its ground, and power supply (see ECU Power Supply Inspection). If the ground and power supply are good, replace the ECU (see ECU section).

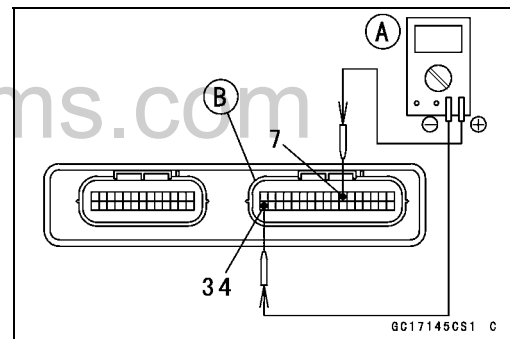

Atmospheric Pressure Sensor (Service Code 15)

★ If the reading is within the standard range, remove the seat cover, and check the input voltage again at the sensor connector.

- Disconnect the atmospheric pressure sensor connector and connect the harness adapter [A] between the harness connector and atmospheric pressure sensor connector.

Special Tool - Sensor Harness Adapter: 57001-1561

- Connect a digital meter to the harness adapter leads. Atmospheric Pressure Sensor [B]

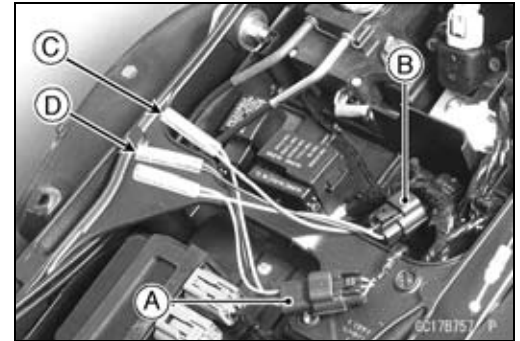

Atmospheric Pressure Sensor Input Voltage Connections to Adapter

Meter (+) → G (sensor BL) lead [C]

Meter (-) → BK (sensor BR/BK) lead [D]

- Measure the input voltage with the engine stopped, and with the connector joined.
- Turn the ignition switch ON.

Input Voltage at Sensor Connector

Standard: DC 4.75 ~ 5.25 V

- ★ If the reading is out of the standard range, check the wiring (see wiring diagram in this section).
- ★ If the reading is good, the input voltage is normal. Check the output voltage.
- Turn the ignition switch OFF.

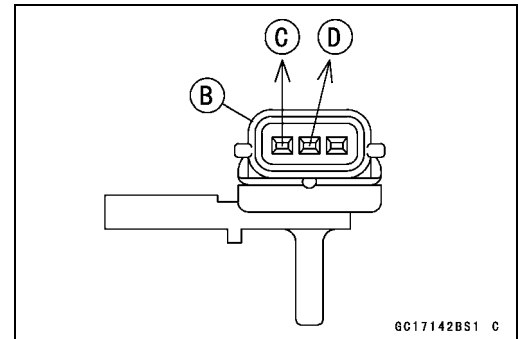
**Output Voltage Inspection**

- Measure the output voltage at the ECU in the same way as input voltage inspection. Note the following.

Digital Meter [A]

ECU Connector [B]

Special Tool - Needle Adapter Set: 57001-1457

Atmospheric Pressure Sensor Output Voltage Connections to ECU Connector

Meter (+) → G/W lead (terminal 11)

Meter (-) → BR/BK lead (terminal 34)

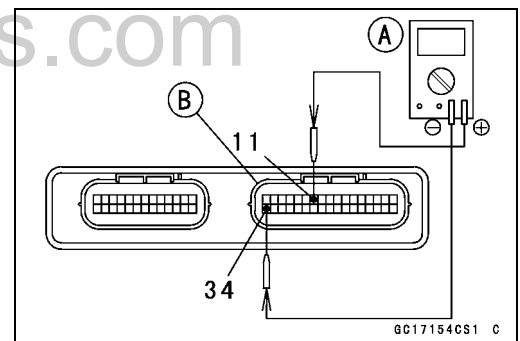
**Output Voltage**

Usable Range: DC 3.80 ~ 4.20 V at the standard atmospheric pressure (101.32 kPa, 76 cmHg abs.)

NOTE

- The output voltage changes according to the local atmospheric pressure.
 - The atmospheric sensor output voltage is based on a nearly perfect vacuum in the small chamber of the sensor. So, the sensor indicates absolute atmospheric pressure.
- ★ If the output voltage is within the usable range, check the ECU for its ground, and power supply (see ECU Power Supply Inspection). If the ground and power supply are good, replace the ECU (see ECU section).

Atmospheric Pressure Sensor (Service Code 15)

★ If the output voltage is far out of the usable range, remove the seat cover, and check the output voltage at the sensor connector [A] (when the wiring is open, the output voltage is about 1.8 V).

- Connect a digital meter [A] to the harness adapter leads. Atmospheric Pressure Sensor [B]

Special Tool - Sensor Harness Adapter: 57001-1561

Atmospheric Pressure Sensor Output Voltage Connections to Adapter

Meter (+) → G/W (sensor G/W) lead

Meter (-) → BK (sensor BR/BK) lead

Output Voltage at Sensor

Usable Range: DC 3.80 ~ 4.20 V at the standard atmospheric pressure (101.32 kPa, 76 cmHg abs.)

- Turn the ignition switch OFF.
- ★ If the output voltage is normal, check the wiring for continuity (see wiring diagram in this section).
- ★ If the output voltage is out of the usable range, replace the sensor.

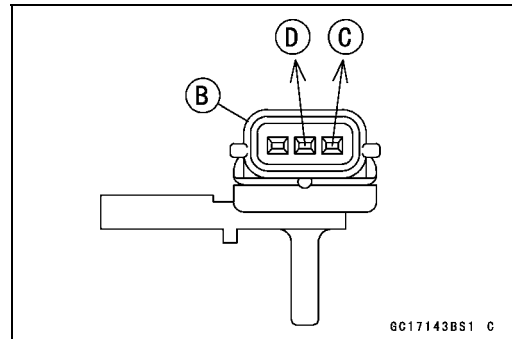
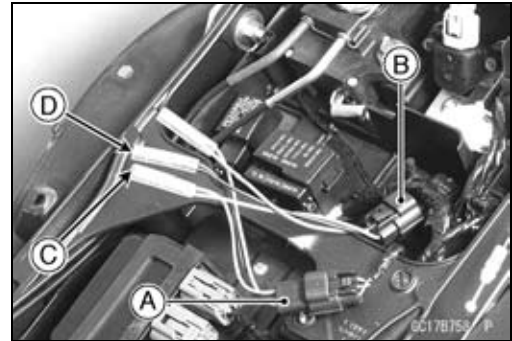

Atmospheric Pressure Sensor Circuit

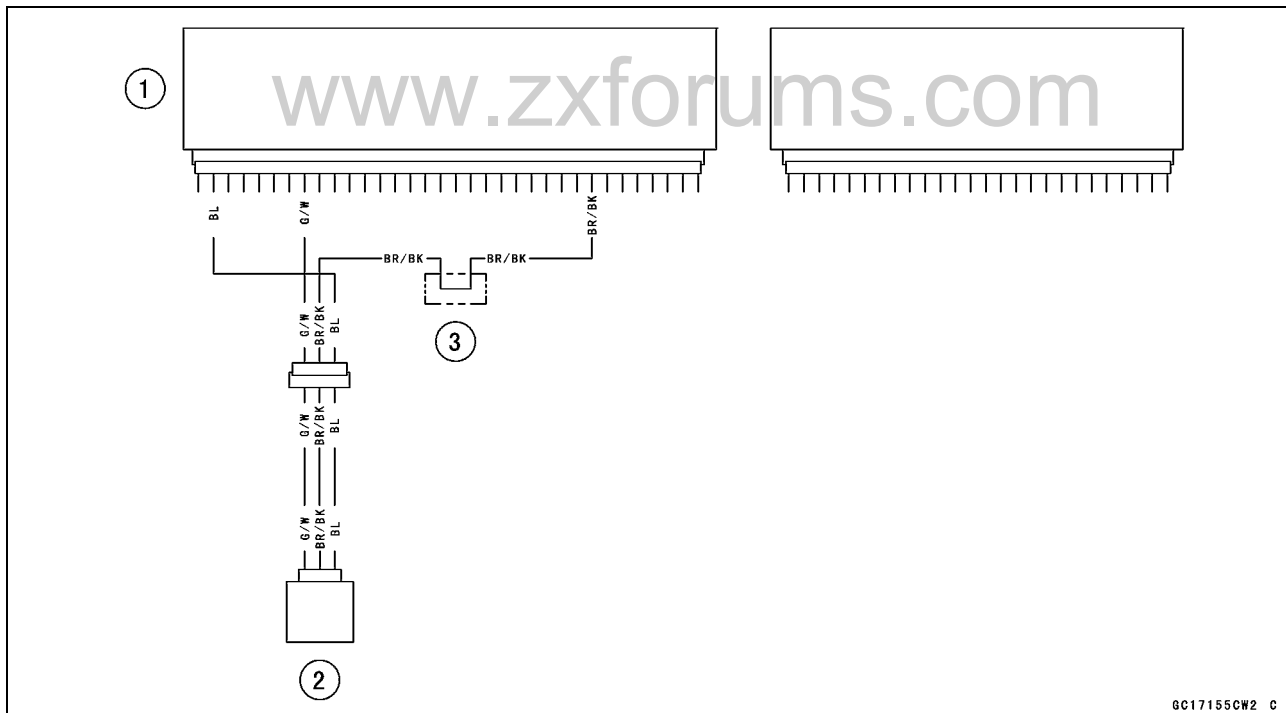

1. ECU
2. Atmospheric Pressure Sensor
3. Water-proof Joint 2

★ If you need to check the atmospheric pressure sensor for various altitudes other than sea level, check the output voltage as follows:

- Determine the local altitude (Elevation).

Atmospheric Pressure Sensor (Service Code 15)

★ If you know the local atmospheric pressure using a barometer, substitute the atmospheric pressure for throttle vacuum pressure in the inlet air pressure sensor chart (see Inlet Air Pressure Sensor section). And get the usable range of the atmospheric pressure sensor output voltage and check if output voltage is within the standard or not in the same way as Output Voltage Inspection of the inlet air pressure sensor.

★ If you know the local altitude, use the following chart.

Atmospheric Pressure/Altitude Relationship

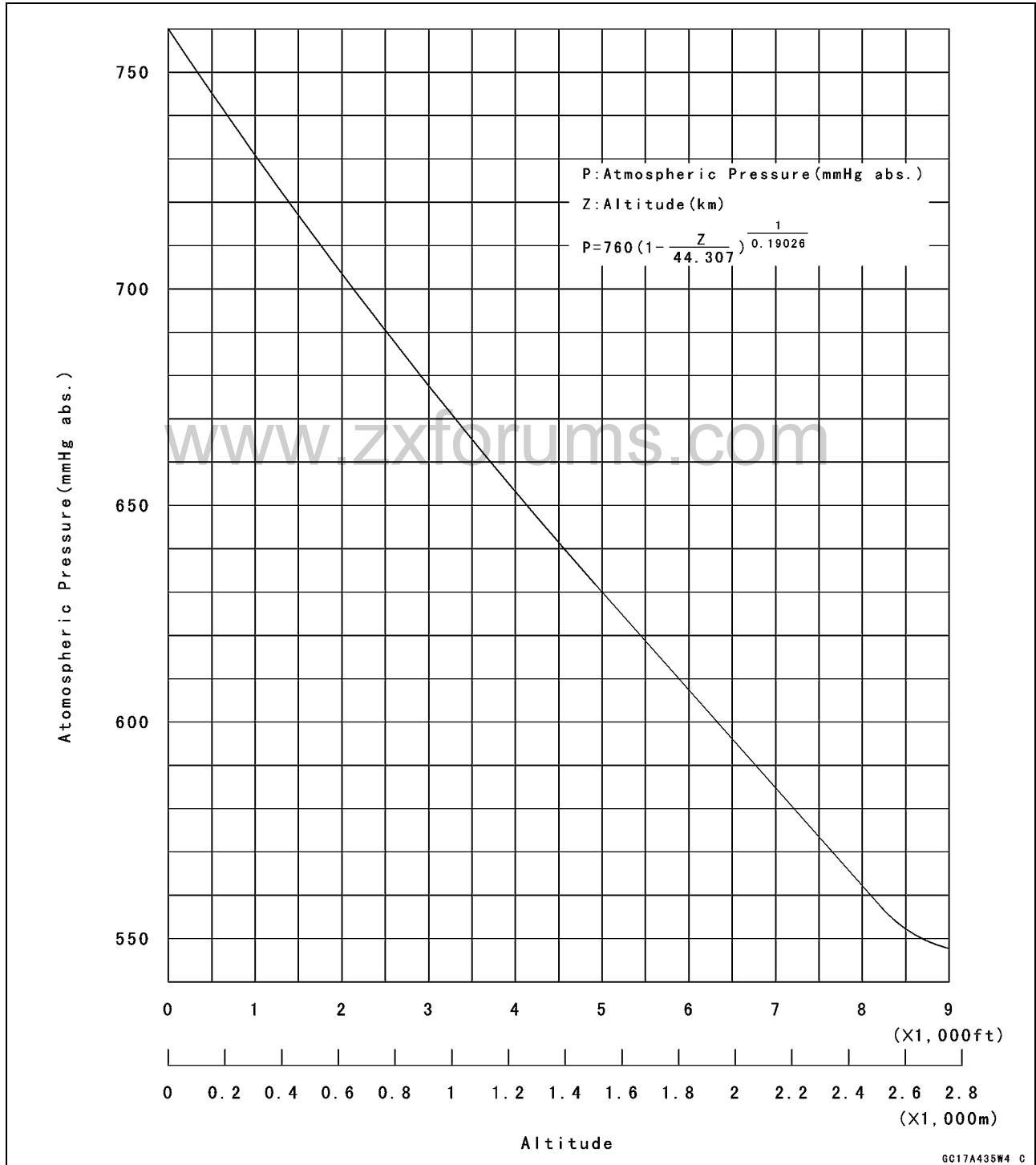

Crankshaft Sensor (Service Code 21)

Crankshaft Sensor Removal/Installation

- Refer to the Crankshaft Sensor Removal/Installation in the Electrical System chapter (see Crankshaft Sensor Removal/Installation in the Electrical System chapter).

Crankshaft Sensor Inspection

- The crankshaft has no power source, and when the engine stops, the crankshaft generates no signals.
- Crank the engine and measure the peak voltage of the crankshaft sensor (see Crankshaft Sensor Peak Voltage Inspection in the Electrical System chapter) in order to check the sensor.
- Check the wiring for continuity (see wiring diagram in this section).

Crankshaft Sensor Circuit

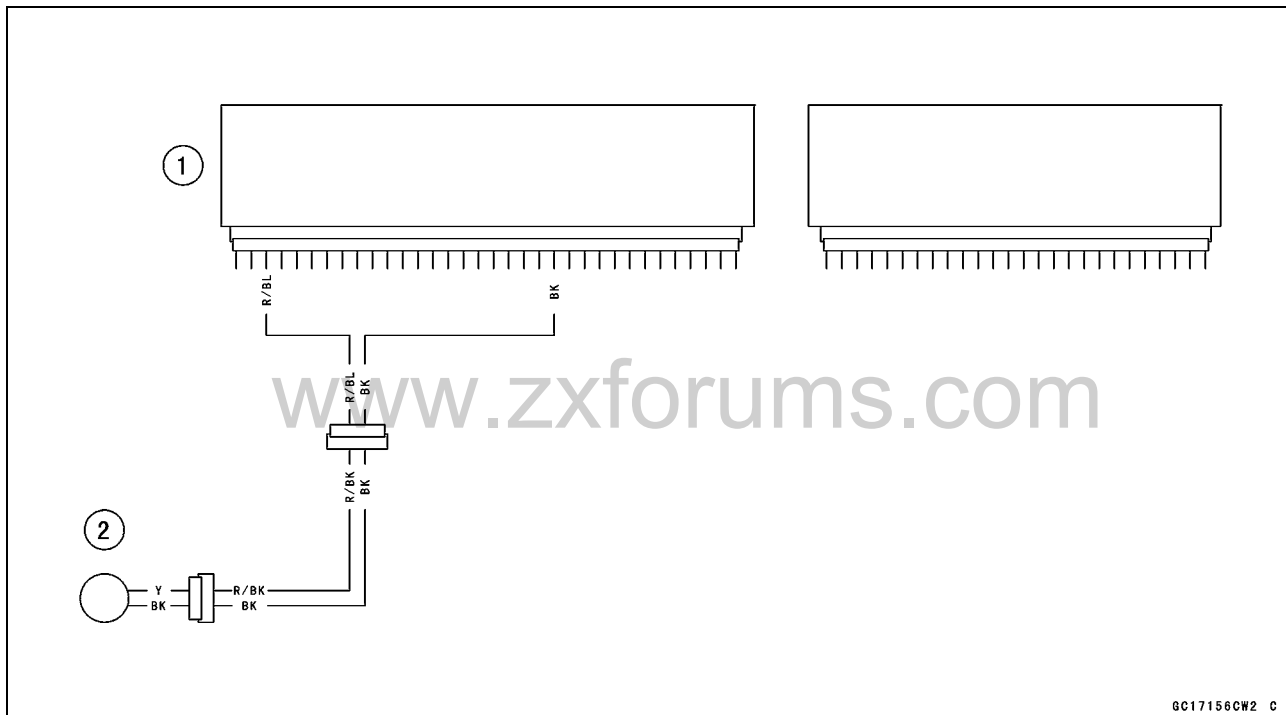

6C17156CW2 C

1. ECU
2. Crankshaft Sensor

Camshaft Position Sensor (Service Code 23)

Camshaft Position Sensor Removal/Installation

The camshaft position sensor detects the position of the camshaft, and distinguishes the cylinder.

- Refer to the Camshaft Position Sensor Removal/Installation in the Electric System chapter (see Camshaft Position Sensor Removal/Installation in the Electric System chapter).

Camshaft Position Sensor Inspection

- The camshaft position sensor have no power source, and when the engine stops, the camshaft position sensor generates no signal.
- Crank the engine and measure the peak voltage of the camshaft position sensor (see Camshaft Position Sensor Peak Voltage Inspection in the Electrical System chapter) in order to check the sensor.
- Check the wiring for continuity (see wiring diagram in this section).

Camshaft Position Sensor Circuit

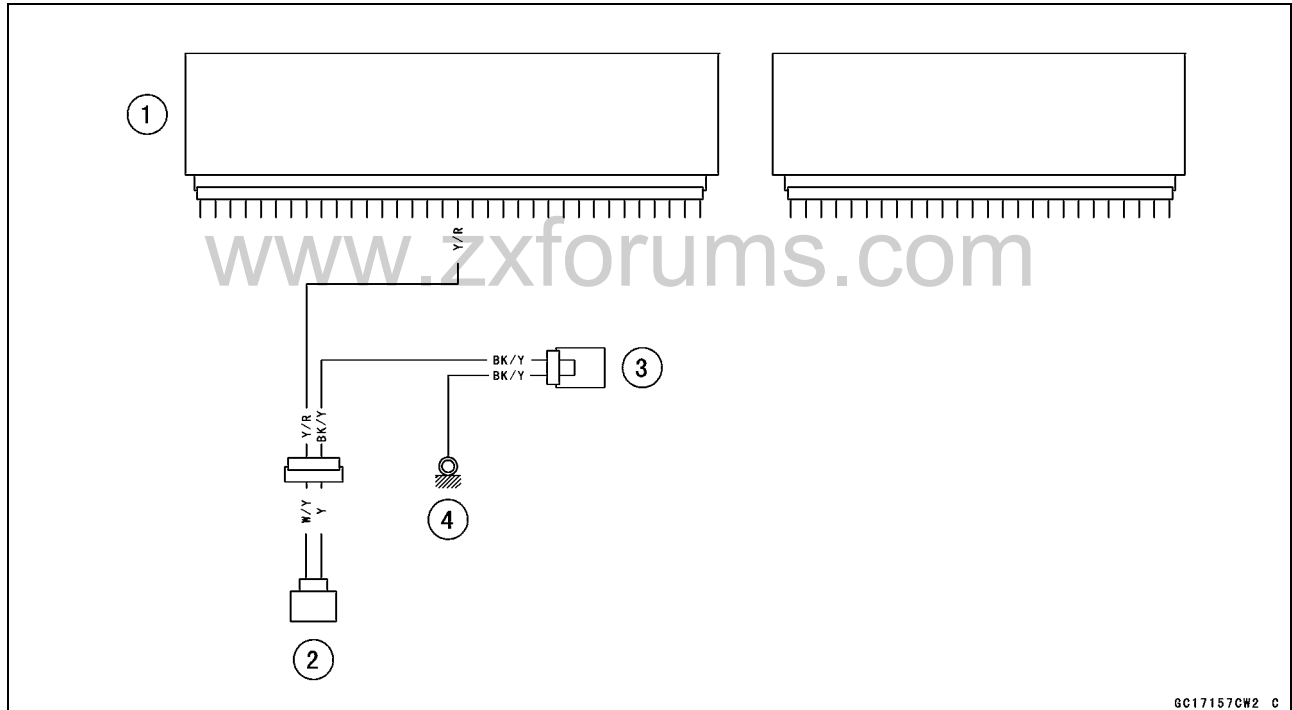

1. ECU
2. Camshaft Position Sensor
3. Joint Connector 1
4. Frame Ground

Speed Sensor (Service Code 24)**Speed Sensor Removal/Installation**

- Refer to the Speed Sensor Removal/Installation in the Electrical System chapter (see Speed Sensor Removal/Installation in the Electrical System chapter).

Input Voltage Inspection**NOTE**

- Be sure the battery is fully charged.
- The input voltage is the same as "Input Voltage Inspection" of the throttle sensor, inlet air pressure sensor and atmospheric pressure sensor.
- Turn the ignition switch OFF.
- Remove the ECU (see ECU Removal).
- Do not disconnect the ECU connectors.
- Connect a digital meter [A] to the connector [B], using the needle adapter set.

Special Tool - Needle Adapter Set: 57001-1457

Speed Sensor Input Voltage**Connections to ECU Connector**

Meter (+) → BL lead (terminal 7)

Meter (-) → BR/BK lead (terminal 34)

- Measure the input voltage with the engine stopped, and with the connectors joined.
- Turn the ignition switch ON.

Input Voltage at ECU Connector

Standard: DC 4.75 ~ 5.25 V

- Turn the ignition switch OFF.
- ★ If the reading of input voltage is less than the standard, check the ECU for its ground, and power supply (see ECU Power Supply Inspection). If the ground and power supply are good, replace the ECU (see ECU section).
- ★ If the input voltage is within the standard range, check the input voltage at the speed sensor connector.
- Disconnect the speed sensor connector [A].

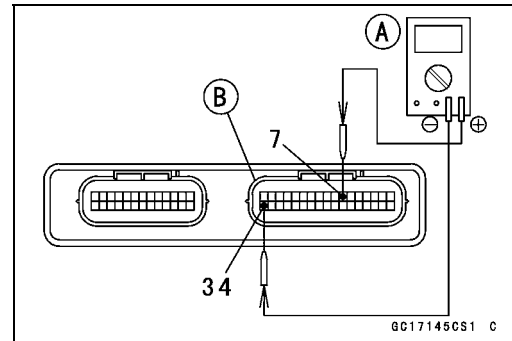

Speed Sensor (Service Code 24)

- Connect the harness adapter [A] between the harness connector and speed sensor connector.

Special Tool - Speed Sensor Measuring Adapter: 57001-1667



- Connect a digital meter to the harness adapter leads.

Speed Sensor Input Voltage Connections to Adapter

Meter (+) → BL lead [A]

Meter (-) → BR/BK lead [B]

- Measure the input voltage with the engine stopped, and with the connectors joined.
- Turn the ignition switch ON.

Input Voltage at Sensor

Standard: DC 4.75 ~ 5.25 V

- ★ If the reading is out of the range, check the wiring (see wiring diagram in this section).
- ★ If the reading is good, check the output voltage.
- Turn the ignition switch OFF.

Output Voltage Inspection

- Before this inspection, inspect the input voltage (see Input Voltage Inspection in this section).

NOTE

○ *Be sure the battery is fully charged.*

- Turn the ignition switch OFF.
- Using the stand, raise the rear wheel off the ground.
- Disconnect the speed sensor connector [A] and connect the harness adapter [B] between the harness connector and speed sensor connector.

Special Tool - Speed Sensor Measuring Adapter: 57001-1667

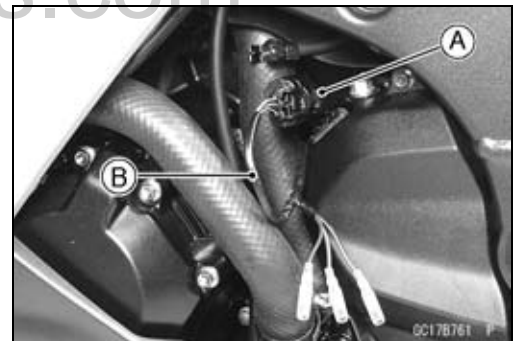
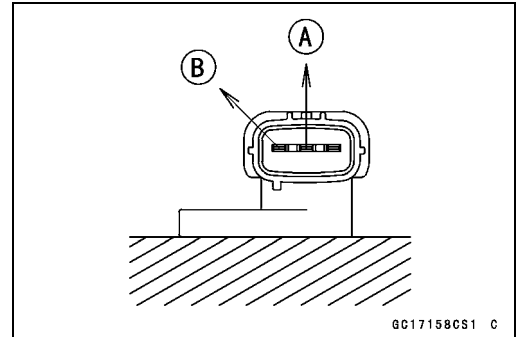

Speed Sensor (Service Code 24)

- Connect a digital meter to the harness adapter leads.

Speed Sensor Output Voltage Connections to Adapter

Meter (+) → BL/Y lead [A]

Meter (-) → BK lead [B]

- Measure the output voltage with the engine stopped, and with the connectors joined.
- Turn the ignition switch ON.

Output Voltage at Sensor

Standard: DC 0.05 ~ 0.09 V or DC 4.5 ~ 4.9V

- Rotate the rear wheel by hand, confirm the output voltage will be raise or lower.
- ★ If the reading is out of the range, replace the speed sensor (see Speed Sensor Removal/Installation in the Electrical System chapter) and check the wiring to ECU (see wiring diagram in this section).
- ★ If the reading, speed sensor and wiring are good, replace the ECU (see ECU section).
- Turn the ignition switch OFF.

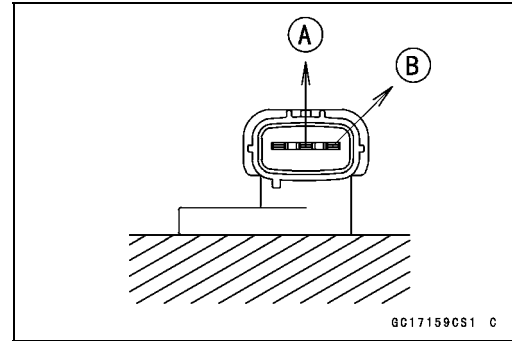

Speed Sensor Circuit

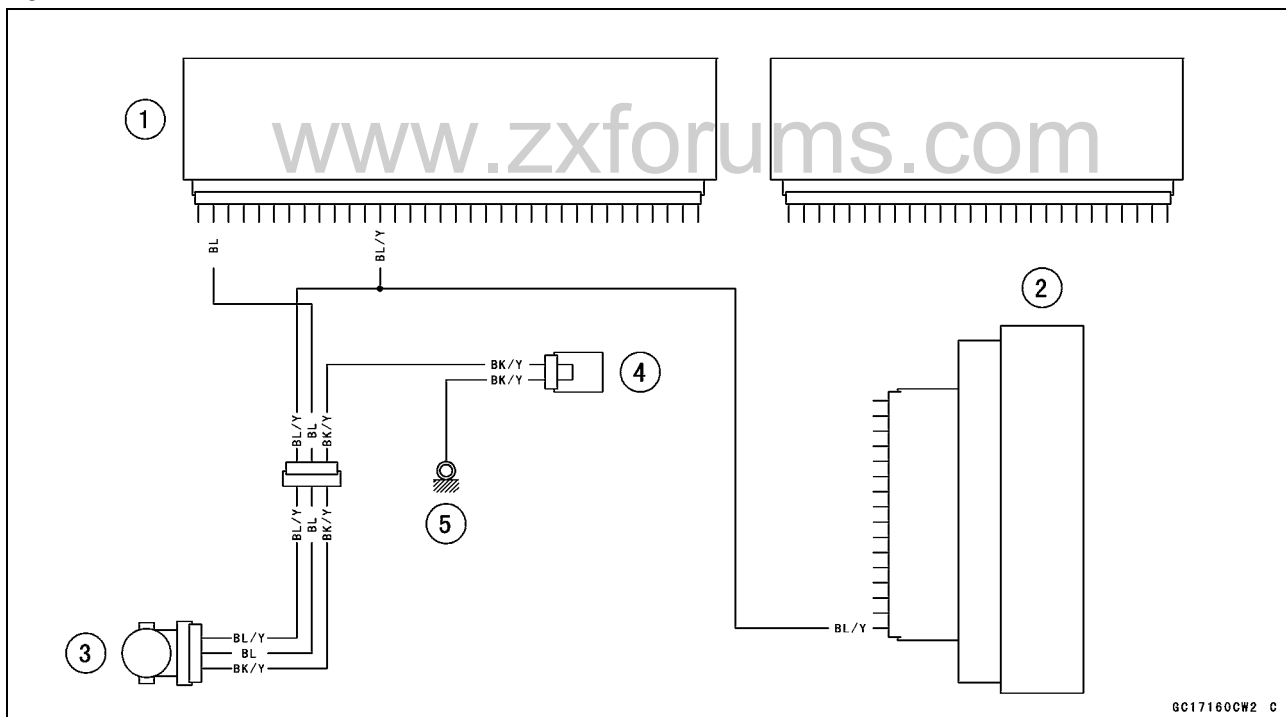

1. ECU
2. Meter Unit
3. Speed Sensor
4. Joint Connector 1
5. Frame Ground

Gear Position Switch (Service Code 25)

Gear Position Switch Removal/Installation

- Refer to the Gear Position Switch Removal/Installation in the Electrical System chapter (see Gear Position Switch Removal/Installation in the Electrical System chapter).

Gear Position Switch Inspection

- Refer to the Gear Position Switch Inspection in the Electrical System chapter (see Gear Position Switch Inspection in the Electrical System chapter).

Input Voltage Inspection

NOTE

○ Be sure the battery is fully charged.

- Turn the ignition switch OFF.
- Remove the ECU (see ECU Removal).
- Do not disconnect the ECU connectors.

- Connect a digital meter [A] to the connector, with the needle adapter set.

Special Tool - Needle Adapter Set: 57001-1457

Gear Position Switch Input Voltage at 1 ~ 6 Gear Positions Connections to ECU Connector

Meter (+) → W/Y lead (terminal 4)

Meter (-) → Engine Ground

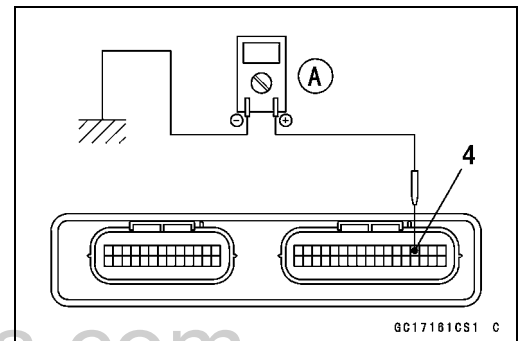

- Measure the switch input voltage with the engine stopped, and with the connector joined.
- Turn the ignition switch ON.

Input Voltage at 1 ~ 6 Gear Positions

Standard:

1st	About 3.0 V
2nd	About 2.5 V
3rd	About 2.0 V
4th	About 1.5 V
5th	About 1.1 V
6th	About 0.7 V

- ★ If the reading is out of the range, check the gear position switch (see Gear Position Switch Inspection in the Electrical System chapter).
- ★ If the switch is good, check the ECU for its ground and power supply (see ECU Power Supply Inspection). If the ground and power supply are good, replace the ECU (see ECU section).
- Turn the ignition switch OFF.

Gear Position Switch (Service Code 25)

Gear Position Switch Circuit

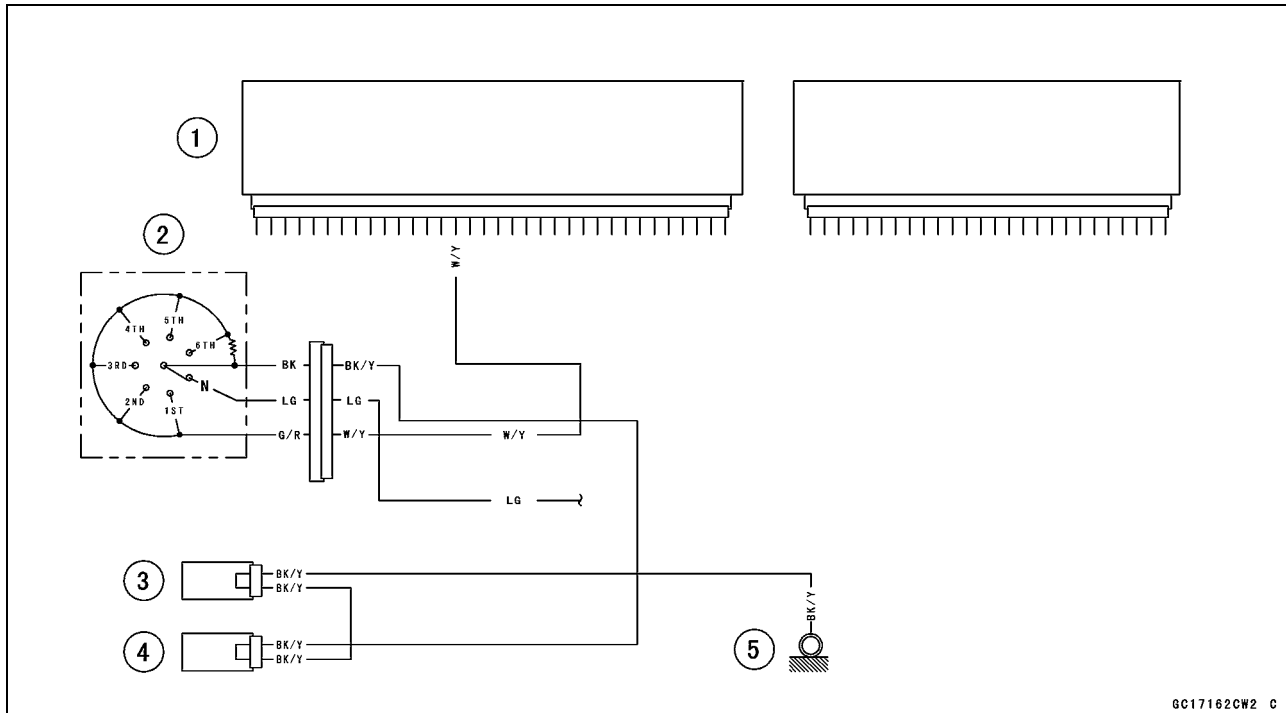

GC17162CW2 C

- 1. ECU
- 2. Gear Position Switch
- 3. Joint Connector 1
- 4. Joint Connector 2
- 5. Frame Ground

www.zxforums.com

Vehicle-down Sensor (Service Code 31)

This sensor has a weight [A] with two magnets inside, and sends a signal to the ECU. But when the motorcycle banks 60 ~ 70° or more to either side (in fact falls down), the weight turns and shuts off the signal. The ECU senses this change, and stops the fuel pump, the fuel injectors, and the ignition system.

Hall IC [B]

When the motorcycle is down, the ignition switch is left ON. If the starter button is pushed, the electric starter turns but the engine doesn't start. To start the engine again, raise the motorcycle, turn the ignition switch OFF, and then ON. When the ignition switch is turned ON, current flows through the latch-up circuit and the transistor in the circuit is turned ON to unlock the latch-up circuit.

Vehicle-down Sensor [A]

Ground Terminal BR/BK [B]

Output Terminal Y/G [C]

Power Source Terminal BL [D]

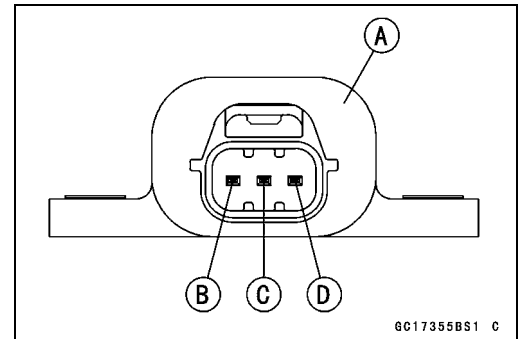
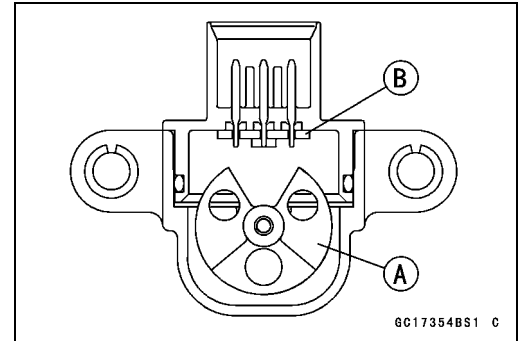

Removal

CAUTION

Never drop the vehicle-down sensor, especially on a hard surface. Such a shock to the sensor can damage it.

- Remove:
 - Seat Cover (see Seat Cover Removal in the Frame chapter)
 - Connector [A]
 - Bolts [B]
 - Vehicle-down Sensor [C]

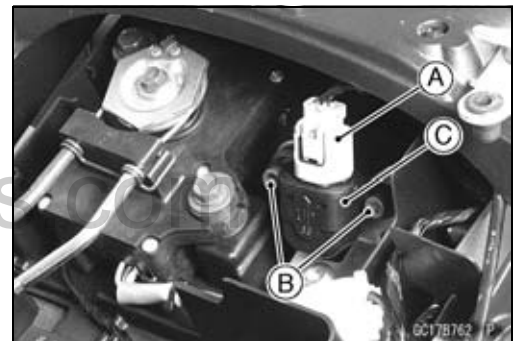

Installation

- The UP mark [A] of the sensor should face upward.

⚠ WARNING

Incorrect installation of the Vehicle-down sensor could cause sudden loss of engine power. The rider could lose balance during certain riding situations, like leaning over in a turn, with the potential for an accident resulting in injury or death. Ensure that the vehicle-down sensor is held in place by the sensor brackets.

- Tighten:
 - Torque - Vehicle-down Sensor Bolts: 6.0 N·m (0.60 kgf·m, 53 in·lb)

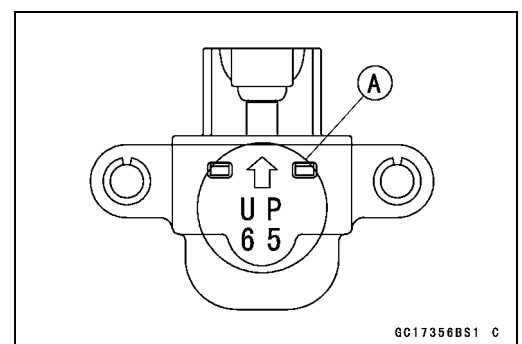

Inspection

NOTE

○Be sure the battery is fully charged.

- Remove the seat cover (see Seat Cover Removal in the Frame chapter).

Vehicle-down Sensor (Service Code 31)

- Connect a digital meter [A] to the connector of the vehicle -down sensor [B], with the needle adapter set [C].

Special Tool - Needle Adapter Set: 57001-1457

Vehicle-down sensor Power Source Voltage

Connections to Sensor

Meter (+) → BL lead [D]

Meter (-) → BR/BK lead [E]

- Turn the ignition switch ON, and measure the power source voltage with the connector joined.

Power Source Voltage at Sensor

Standard: DC 4.75 ~ 5.25 V

- Turn the ignition switch OFF.
- ★ If there is no voltage, check the following:
 - Battery (see Charging Condition Inspection in the Electrical System chapter)
 - ECU Main Fuse 15 A (see Fuse Inspection in the Electrical System chapter)
- ★ If the power source is normal, check the output voltage.

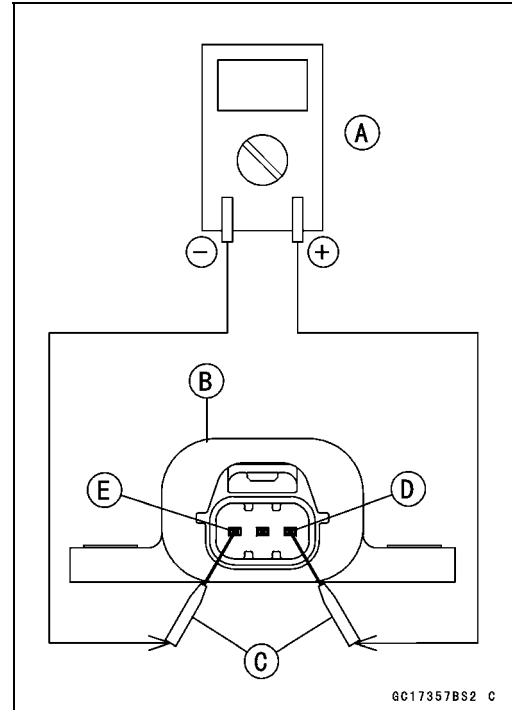

- Turn the ignition switch OFF.
- Remove the vehicle-down sensor.
- Do not disconnect the sensor connector.
- Connect a digital meter [A] to the connector, with needle adapter set [B].

Special Tool - Needle Adapter Set: 57001-1457

Vehicle-down sensor Output Voltage

Connections to Sensor

Meter (+) → Y/G lead [C]

Meter (-) → BR/BK lead [D]

- Hold the sensor vertically.
- Turn the ignition switch ON, and measure the output voltage with the connector joined.
- Tilt the sensor 60 ~ 70° or more [E] right or left, then hold the sensor almost vertical with the arrow mark pointed up, and measure the output voltage.

Output Voltage at Sensor

Standard: with sensor arrow mark pointed up: 3.55 ~ 4.45 V

with sensor tilted 60 ~ 70° or more right or left: 0.65 ~ 1.35 V

NOTE

○ If you need to test again, turn the ignition switch OFF, and then ON.

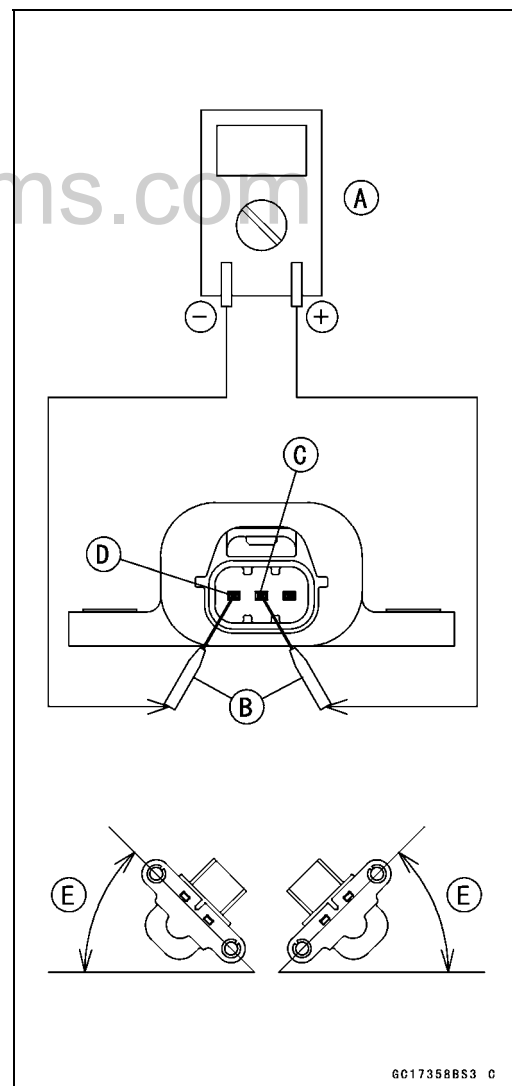

Vehicle-down Sensor (Service Code 31)

- Turn the ignition switch OFF.
- Remove the needle adapter set, and apply silicone sealant to the seals of sensor the connector for water-proofing.

Sealant - Kawasaki Bond (Silicone Sealant): 56019-120

- ★ If the output voltage is out of the specified, replace the vehicle-down sensor.

Vehicle-down Sensor Circuit

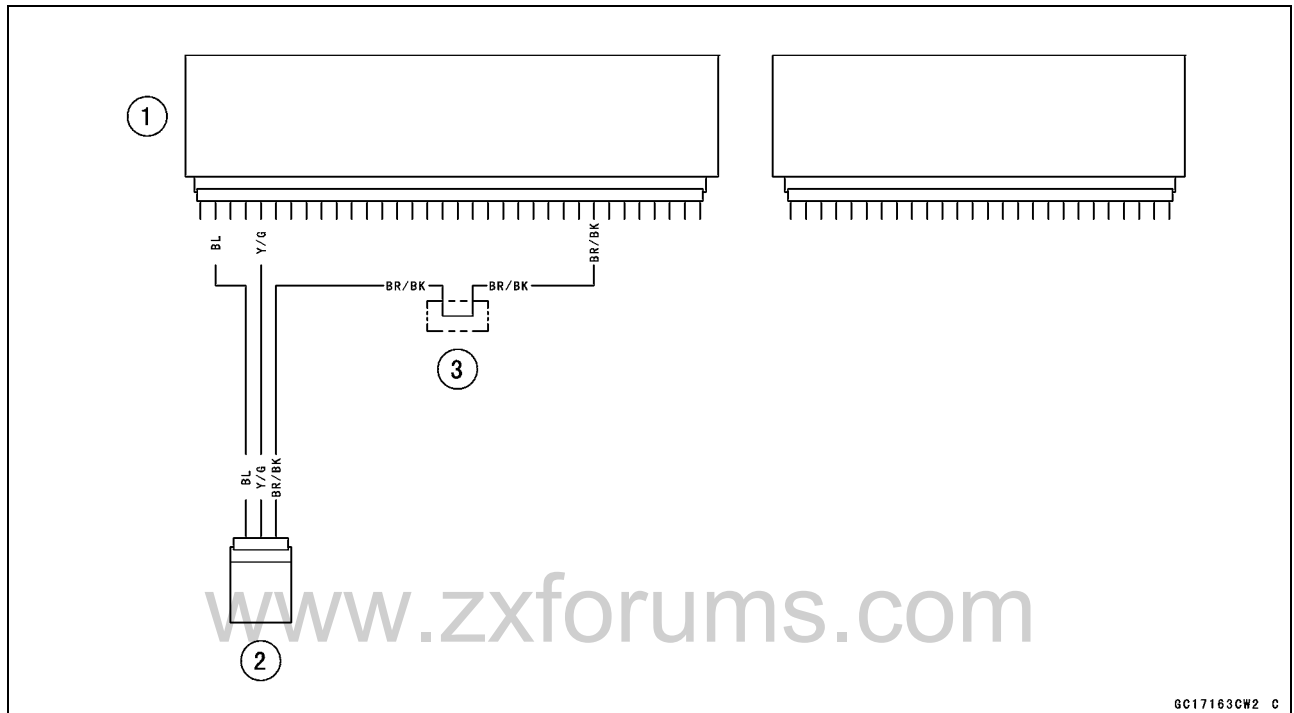

1. ECU
2. Vehicle-down Sensor
3. Water-proof Joint 2

Subthrottle Sensor (Service Code 32)

The subthrottle sensor is a rotating variable resistor that change output voltage according to throttle operating. The ECU senses this voltage change and determines fuel injection quantity, and ignition timing according to engine rpm, and throttle opening.

- Input Terminal [A]
- Output Terminal [B]
- Ground Terminal [C]

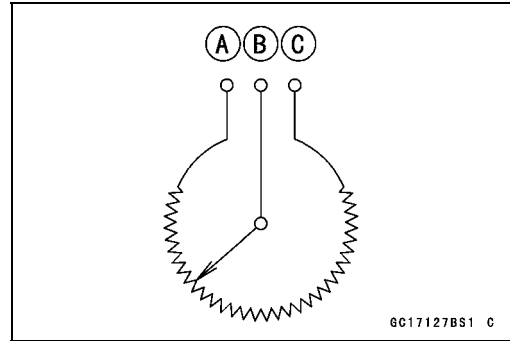

Subthrottle Sensor Removal/Adjustment

CAUTION

Do not remove or adjust the subthrottle sensor since it has been adjusted and set with precision at the factory.
 Never drop the throttle body assy, especially on a hard surface. Such a shock to the sensor can damage it.

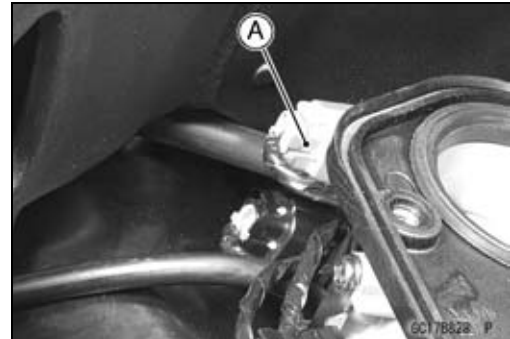

Subthrottle Sensor Connector [A]

Input Voltage Inspection

NOTE

○Be sure the battery is fully charged.

- Turn the ignition switch OFF.
- Remove the ECU (see ECU Removal).
- Do not disconnect the ECU connectors.

- Connect a digital meter [A] to the connector [B], using the needle adapter set.

Special Tool - Needle Adapter Set: 57001-1457

Subthrottle Sensor Input Voltage Connections to ECU Connector

- Meter (+) → BL lead (terminal 7)
- Meter (-) → BR/BK lead (terminal 34)

- Measure the input voltage with the engine stopped, and with the connectors joined.
- Turn the ignition switch ON.

Input Voltage at ECU Connector
 Standard: DC 4.75 ~ 5.25 V

- Turn the ignition switch OFF.
- ★ If the reading of input voltage is less than the standard, check the ECU for its ground, power supply and wiring shorted. If the ground and power supply are good, replace the ECU (see ECU section).
- ★ If the input voltage is within the standard range, check the input voltage at the subthrottle sensor connector.

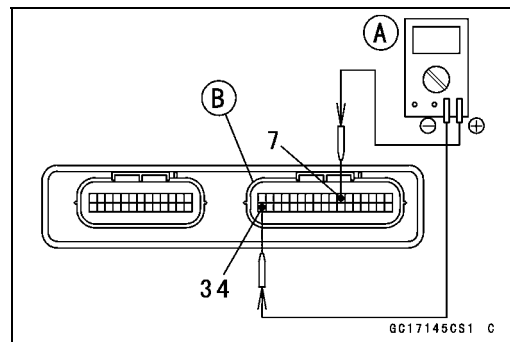

Subthrottle Sensor (Service Code 32)

- Disconnect the subthrottle sensor connector [A] and connect the harness adapter [B] between the harness connector and subthrottle sensor connector.

Special Tool - Throttle Sensor Setting Adapter: 57001-1538

- Connect a digital meter to the harness adapter leads.

**Subthrottle Sensor Input Voltage
Connections to Adapter**

Meter (+) → BK (sensor BL) lead

Meter (-) → W (sensor BR/BK) lead

- Measure the sensor input voltage with the engine stopped, and with the connector joined.
- Turn the ignition switch ON.

Input Voltage at Sensor

Standard: DC 4.75 ~ 5.25 V

- Turn the ignition switch OFF.
- ★ If the reading is out of the range, check the wiring (see wiring diagram in this section).
- ★ If the reading is good, check the output voltage of the sensor.

Output Voltage Inspection

- Measure the output voltage at the ECU in the same way as input voltage inspection. Note the following.

Digital Meter [A]

Connectors [B]

Special Tool - Needle Adapter Set: 57001-1457

Subthrottle Sensor Output Voltage

Connections to ECU Connector

Meter (+) → BL/W lead (terminal 27)

Meter (-) → BR/BK lead (terminal 34)

- Turn the ignition switch ON.
- Measure the output voltage when the subthrottle valve is fully opened or completely closed by hand.

Output Voltage at ECU

Standard: DC 0.77 ~ 4.22 V (at subthrottle valve full opening to closing)

NOTE

- The throttle sensor is operating correctly if the following voltages are obtained:

- DC 0.77 V (or slightly higher) with the subthrottle valve at the closed position.
- DC 4.22 V (or slightly lower) with the subthrottle valve at the fully open position.

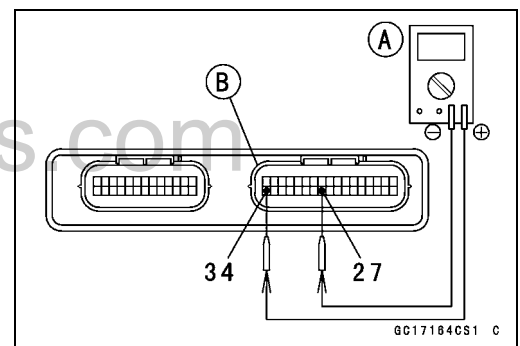
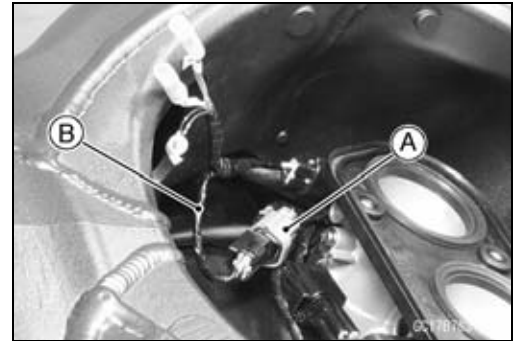

CAUTION

Do not remove or adjust the subthrottle sensor. It has been adjusted and set with precision at the factory.

Never drop the throttle body assy, can especially on a hard surface. Such a shock to the sensor can damage it.

Subthrottle Sensor (Service Code 32)

★ If the output voltage is within the standard range, check the ECU for its ground, and power supply (see ECU Power Supply Inspection). If the ground and power supply are good, replace the ECU (see ECU Removal).

★ If the output voltage is far out of the standard range (e.g. when the wiring is open, the reading is 0 V), check the output voltage again at the sensor connector.

- Disconnect the subthrottle sensor connector [A] and connect the harness adapter [B] between the harness connector and subthrottle sensor connector.

Special Tool - Throttle Sensor Harness Adapter: 57001-1538

- Connect a digital meter to the harness adapter leads.

**Subthrottle Sensor Output Voltage
Connections to Adapter**

Meter (+) → R (sensor BL/W) lead

Meter (–) → W (sensor BR/BK) lead

- Measure the sensor output voltage with the engine stopped, and with the connector joined.
- Turn the ignition switch ON.
- Measure the output voltage when the subthrottle valve is fully opened or completely closed by hand.

Output Voltage at Sensor

Standard: DC 0.77 ~ 4.22 V (at subthrottle valve full opening to closing)

NOTE

○ The throttle sensor is operating correctly if the following voltages are obtained:

- DC 0.77 V (or slightly higher) with the subthrottle valve at the closed position.
- DC 4.22 V (or slightly lower) with the subthrottle valve at the fully open position.

CAUTION

Do not remove or adjust the subthrottle sensor. It has been adjusted and set with precision at the factory.

Never drop the throttle body assy, especially on a hard surface. Such a shock to the sensor can damage it.

NOTE

○ The standard voltage refers to the value when the voltage reading at the Input Voltage Inspection shows 5V exactly.

○ When the input voltage reading shows other than 5V, derive a voltage range as follows.

Example:

In the case of a input voltage of 4.75 V.

$$0.77 \times 4.75 \div 5.00 = 0.73 \text{ V}$$

$$4.22 \times 4.75 \div 5.00 = 4.01 \text{ V}$$

Thus, the valid range is 0.73 ~ 4.01 V

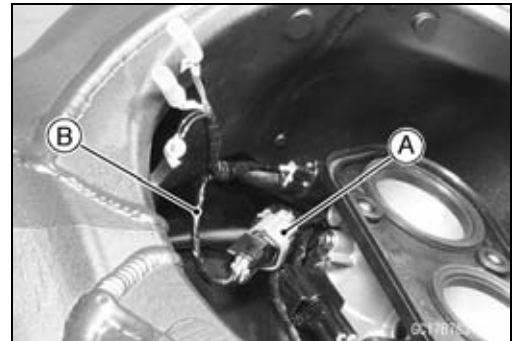

Oxygen Sensor #1-not activated (Service Code 33) - Europe Models

Oxygen Sensor #1 Removal/Installation

- Refer to the Oxygen Sensor Removal (Europe Models) in the Electrical System chapter (see Oxygen Sensor Removal (Europe Models) in the Electrical System chapter).

Oxygen Sensor #1 Inspection

NOTE

○The oxygen sensor itself is the same for #1 [A] and #2 [B], but wiring of the main harness side is different.

- Warm up the engine thoroughly until the radiator fan starts.
- Turn the ignition switch OFF.
- Remove the left middle fairing (see Middle Fairing Removal in the Frame chapter)
- Connect a digital meter [A] to the oxygen sensor #1 lead connector [B] (sensor side), using the needle adapter set [C].

Special Tool - Needle Adapter Set: 57001-1457

Oxygen Sensor #1 Output Voltage
Connections to Oxygen Sensor Connector

Meter (+) → BK lead

Meter (-) → GY lead

- Remove:
Fuel Tank (see Fuel Tank Removal)
Air Cleaner Housing (see Air Cleaner Housing Removal)
- Separate the hoses [A] from the air suction valve covers [B].

- Install the suitable plugs [A] on the fitting of the air suction valve covers [B], and shut off the secondary air.

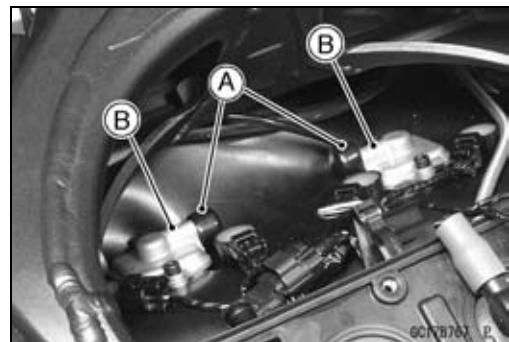
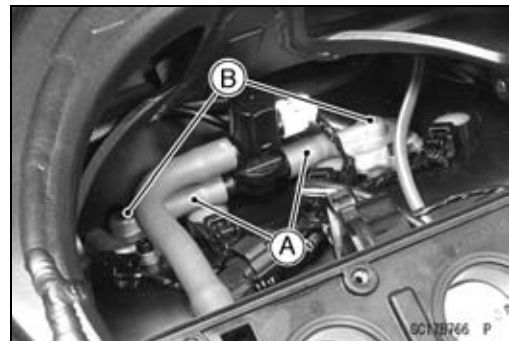
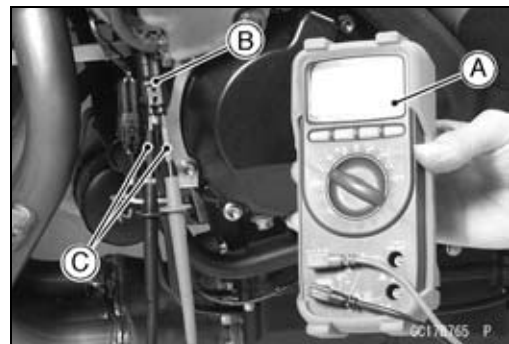
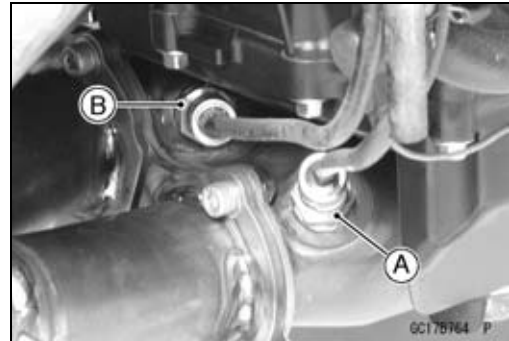

Oxygen Sensor #1-not activated (Service Code 33) - Europe Models

- Connect the following parts temporary.
 - Fuel Pump Lead Connector [A]
 - Extension Tube [B]
- Special Tool - Extension Tube: 57001-1578**

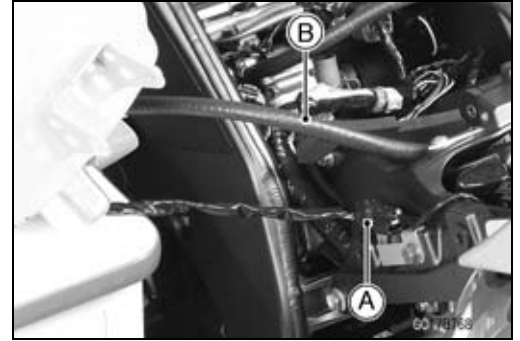

- Turn the ignition switch ON.
- Start the engine, and let it idle.
- Measure the output voltage of the sensor with the connector joined.

Oxygen Sensor #1 Output Voltage (with Plugs)

Standard: 0.45 ~ 2.5 V

- Next, remove the plugs from the fittings [A] with idling.

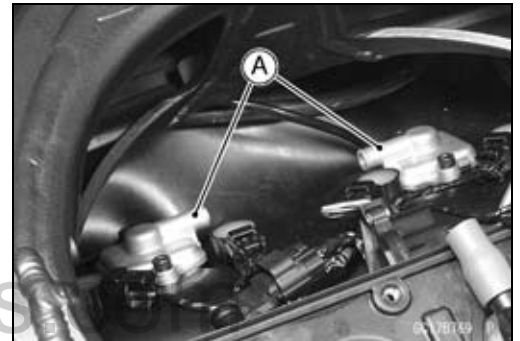

- Measure the output voltage of the sensor with the connector joined.

Oxygen Sensor #1 Output Voltage (without Plugs)

Standard: 0.05 ~ 0.45 V

- ★ If the reading is within range (with plugs: 0.45 ~ 2.5 V , without plugs: 0.05 ~ 0.45 V), the oxygen sensor is good.
 - ★ If the reading is without range, replace the oxygen sensor #1.
 - Remove the needle adapter set, and apply silicone sealant to the seals of the connector for waterproofing.
- Sealant - Kawasaki Bond (Silicone Sealant): 56019-120**

Oxygen Sensor #1-not activated (Service Code 33) - Europe Models

Oxygen Sensor Circuit

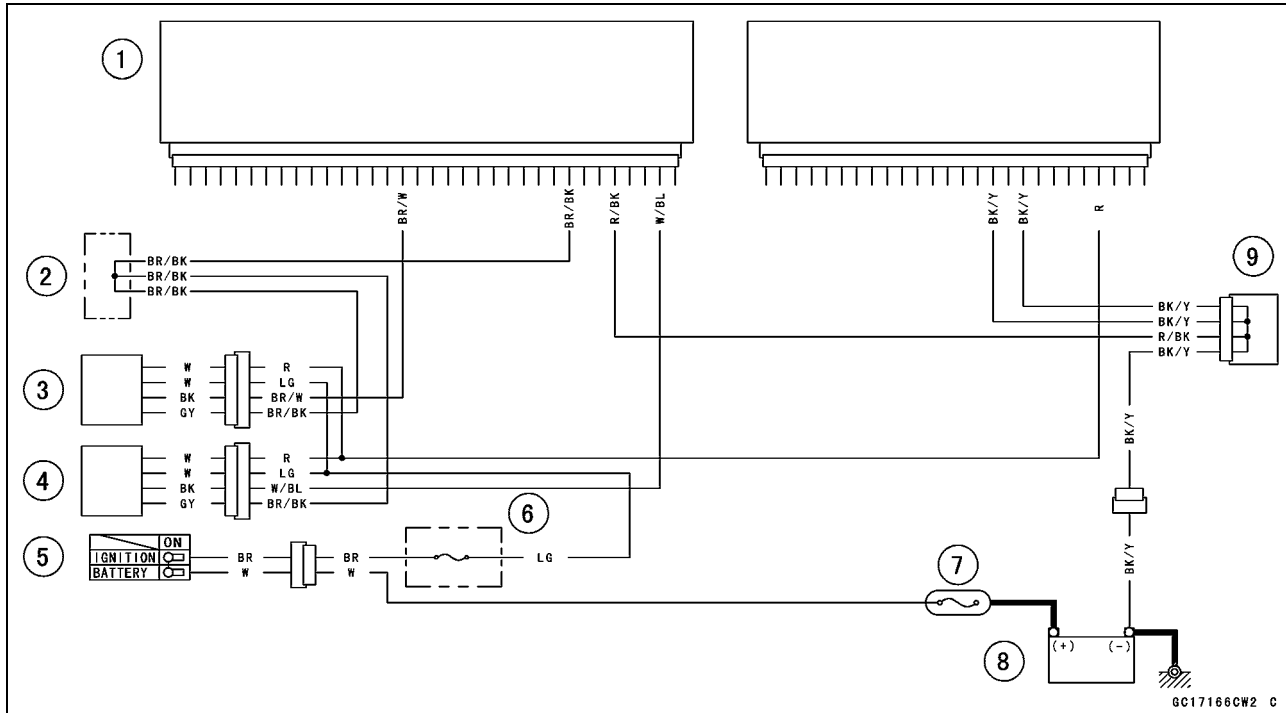

GC17166CW2 C

- 1. ECU
- 2. Water-proof Joint 2
- 3. Oxygen Sensor #2
- 4. Oxygen Sensor #1
- 5. Ignition Switch
- 6. Oxygen Sensor Heater Fuse 10 A
- 7. Main Fuse 30 A
- 8. Battery 12 V 10 Ah
- 9. Joint Connector 3

www.zxforums.com

Exhaust Butterfly Valve Actuator Sensor (Service Code 34)

Exhaust Butterfly Valve Actuator Sensor Inspection

- Turn the ignition switch OFF.
- Remove the seat cover (see Seat Cover Removal in the Frame chapter).
- Disconnect the exhaust butterfly valve actuator sensor connector.
- Connect a digital meter [A] to the exhaust butterfly valve actuator sensor connector [B].
- Measure the exhaust butterfly valve actuator sensor resistance.

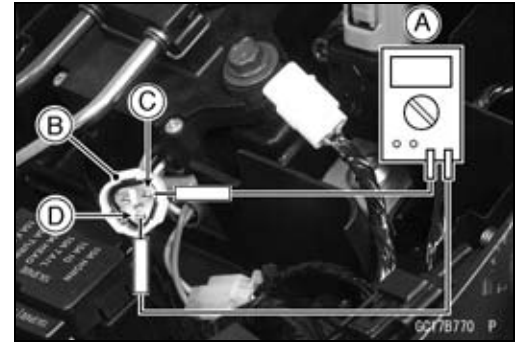

Exhaust Butterfly Valve Actuator Sensor Resistance

Connections: W lead [C] ↔ BK lead [D]

Standard: 4 ~ 6 kΩ

- ★ If the reading is out of the range, replace the exhaust butterfly valve actuator (see Exhaust Butterfly Valve Actuator Removal).

Exhaust Butterfly Valve Actuator Sensor Circuit

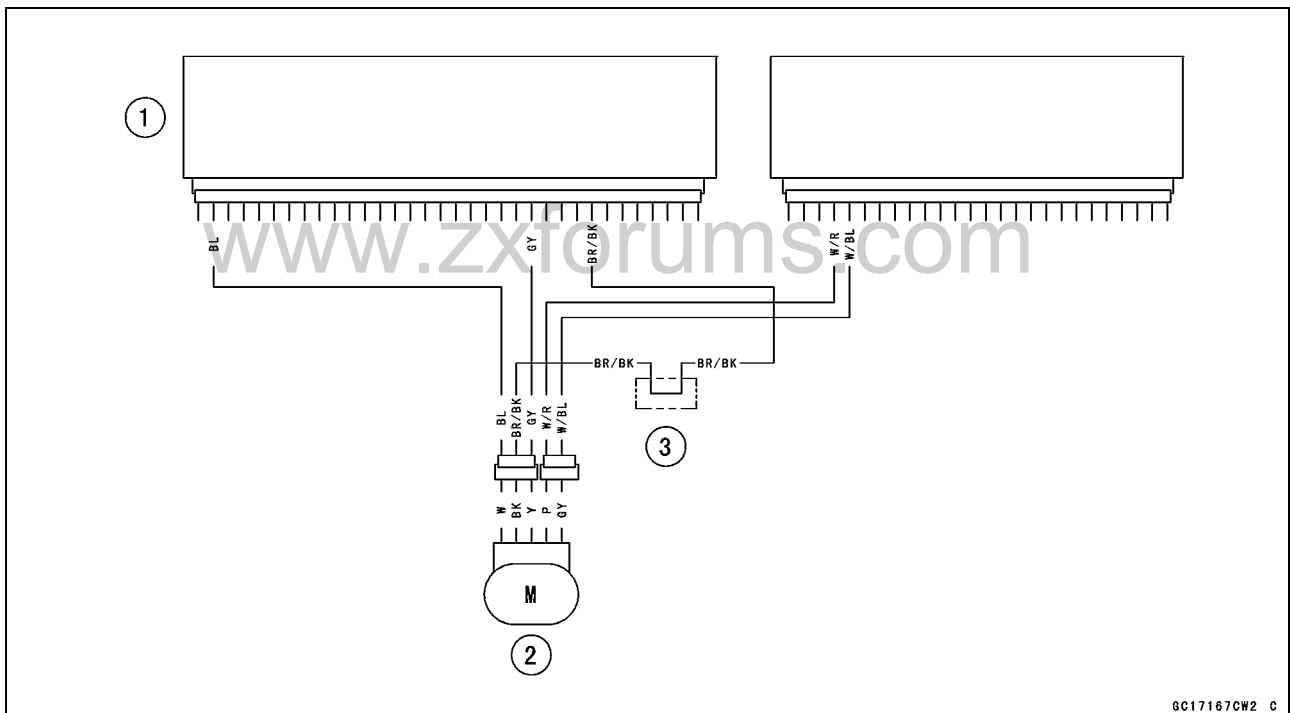

1. ECU
2. Exhaust Butterfly Valve Actuator
3. Water-proof Joint 2

Immobilizer Amplifier (Service Code 35)

Antenna Resistance Inspection

- Remove the left upper inner fairing (see Upper Inner Fairing Removal in the Frame chapter).
- Disconnect the antenna lead connector [A].
- Measure the resistance of the antenna coil in the ignition switch as follows.

Antenna Resistance

Connections to Antenna

Meter → BK lead

Meter → BK lead

Standard: About 0.6 ~ 0.9 Ω

- ★ If the resistance is out of the standard range, replace the ignition switch.

Amplifier Input Voltage Inspection

NOTE

○ Be sure the battery is fully charged.

- Turn the ignition switch OFF.
- Remove the left middle fairing (see Middle Fairing Removal in the Frame chapter).
- Connect a digital meter to the amplifier connector [A], using the needle adapter set.

Special Tool - Needle Adapter Set: 57001-1457

Amplifier Input Voltage

Connections to Connector

Meter (+) → BR/W lead

Meter (-) → BK/Y lead

- Measure the input voltage with the engine stopped, and with the connector joined.
- Turn the ignition switch ON.

Input Voltage

Standard: Battery Voltage

- Turn the ignition switch OFF.
- ★ If the reading is out of the range, check the wiring (see wiring diagram in next section).
- ★ If the reading and antenna resistance are good, replace the amplifier (see Immobilizer System Parts Replacement in the Electrical System chapter).

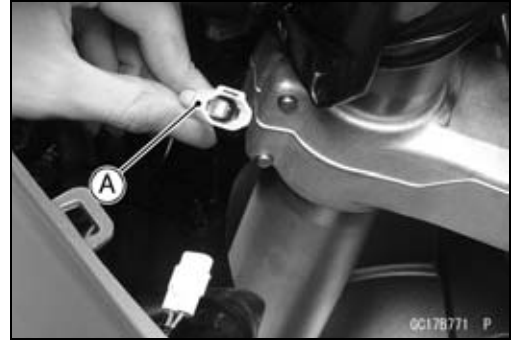

Blank Key Detection (Service Code 36)

- This code appears in the following conditions.
- The transponder [A] in the master and/or user key is malfunction.
- When the spare key of unregistration is used.
- When the master key is registered in the registered ECU.
- Therefore, the service code 36 will disappear when the above issue is solved.



User Key Inspection

- Register the user key correctly (see Key Registration in the Electrical System chapter).
- ★ If the service code 36 appears again, the transponder in the key is malfunction, replace it.

Immobilizer System Circuit

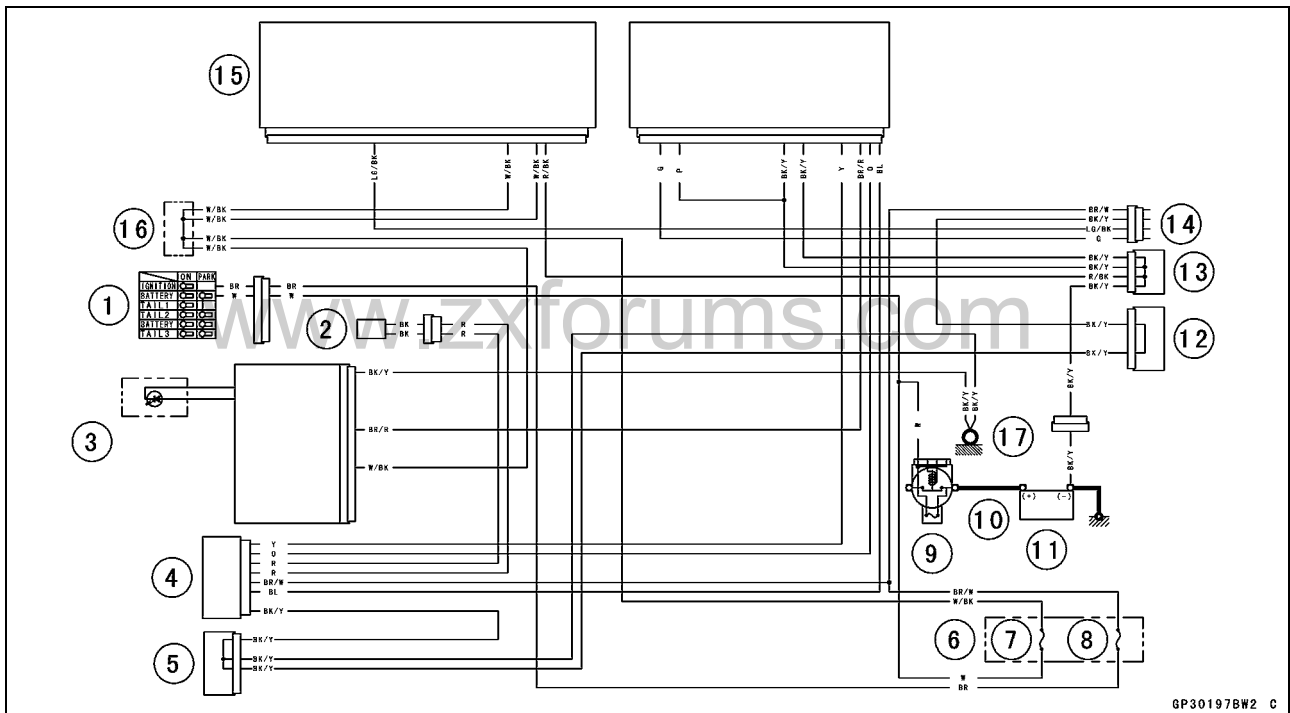

1. Ignition Switch
 2. Immobilizer Antenna
 3. Meter Unit
 4. Immobilizer Amplifier
 5. Joint Connector 1
 6. Fuse Box
 7. ECU Fuse 15 A
 8. Ignition Fuse 15 A
 9. Main Fuse 30 A
 10. Starter Relay
 11. Battery 12 V 10 Ah
 12. Joint Connector 2
 13. Joint Connector 3
 14. Immobilizer/Kawasaki Diagnostic System Connector
 15. ECU
16. Water-proof Joint 1
17. Frame Ground

Fuel Pump Relay (Service Code 46)

Fuel Pump Relay Removal

CAUTION

Never drop the relay, especially on a hard surface. Such a shock to the relay can damage it.

- The fuel pump relay is included in the relay box.
- Remove the front seat (see Front Seat Removal in the Frame chapter).
- Remove the relay box [A] from the bracket and disconnect the connectors.

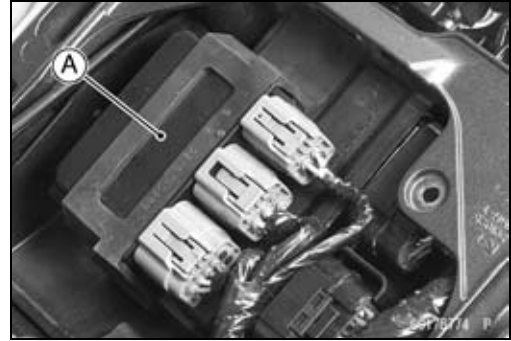

Fuel Pump Relay Inspection

- Remove the relay box (see Fuel Pump Relay Removal).
- Connect the hand tester [A] and one 12 V battery to the relay connector as shown.

Special Tool - Hand Tester: 57001-1394

- Relay Coil Terminals [1] and [2]
- Relay Switch Terminals [3] and [4]

Testing Relay

Tester range: 1 Ω range

- Criteria: When battery is connected → 0 Ω
- When battery is disconnected → ∞ Ω

★ If the relay does not work as specified, replace the relay box.

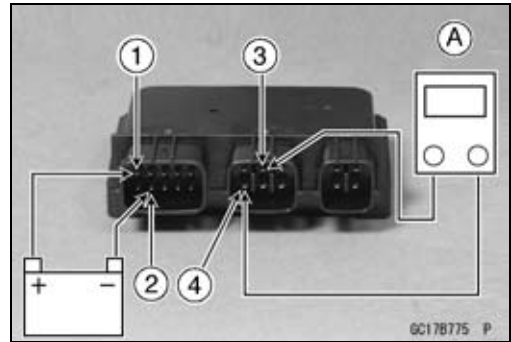

Fuel Pump Relay Circuit

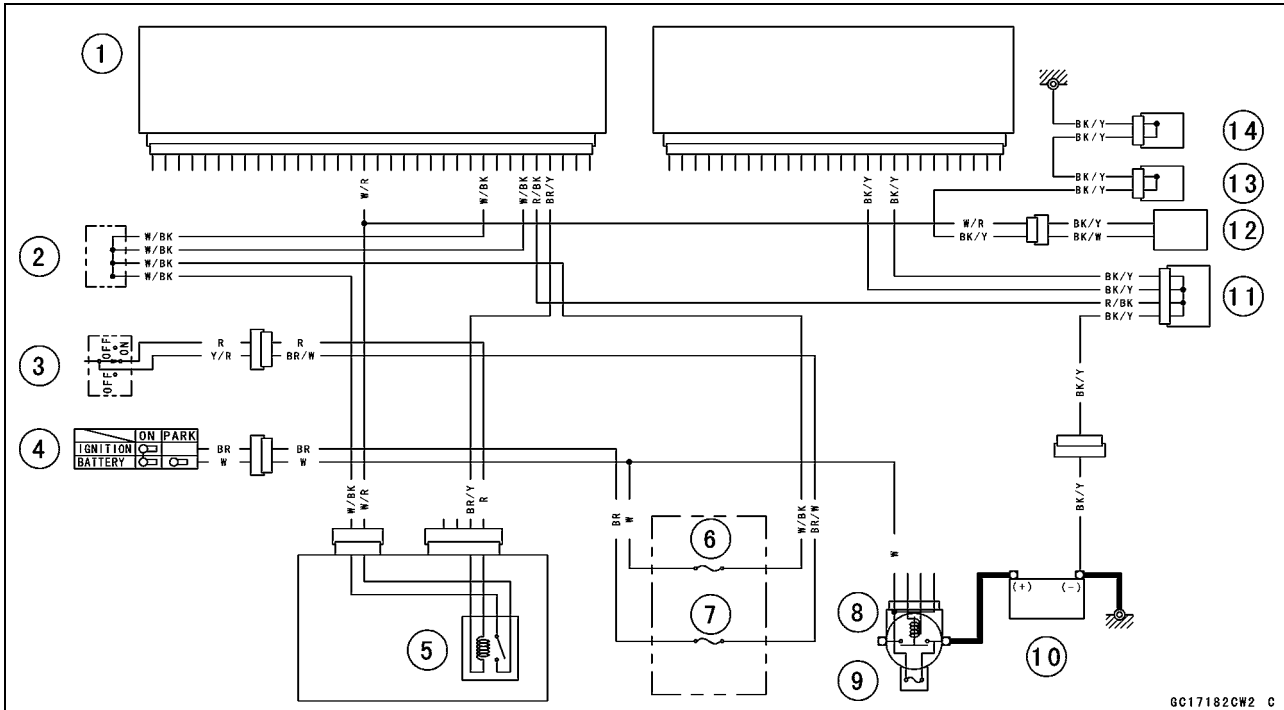

- 1. ECU
- 2. Water-proof Joint 1
- 3. Engine Stop Switch
- 4. Ignition Switch
- 5. Fuel Pump Relay
- 6. Ignition Fuse 15 A
- 7. ECU Fuse 15 A

- 8. Starter Reply
- 9. Main Fuse 30 A
- 10. Battery 12 V 10 Ah
- 11. Joint Connector 3
- 12. Fuel Pump
- 13. Joint Connector 2
- 14. Joint Connector 1

Stick Coils #1, #2, #3, #4: (Service Code 51, 52, 53, 54)

- Stick Coil #1: Service Code 51
- Stick Coil #2: Service Code 52
- Stick Coil #3: Service Code 53
- Stick Coil #4: Service Code 54

Removal/Installation**CAUTION**

Never drop the stick coils, especially on a hard surface. Such a shock to the stick coil can damage it.

- Refer to the Stick Coil (Ignition Coil together with Spark Plug Cap) Removal/Installation in the Electrical System chapter (see Stick Coil (Ignition Coil together with Spark Plug Cap) Removal/Installation in the Electrical System chapter).

Input Voltage Inspection**NOTE**

○Be sure the battery is fully charged.

- Turn the ignition switch OFF.
- Remove the ECU (see ECU Removal).
- Do not disconnect the ECU connectors.
- Connect a digital meter [A] as shown, with the needle adapter set.

Special Tool - Needle Adapter Set: 57001-1457

Stick Coil Input Voltage at ECU**Connections for Stick Coil #1**

- Meter (+) → BK lead (terminal 47)
- Meter (-) → BK/Y lead (terminal 52)

Connections for Stick Coil #2

- Meter (+) → BK/G lead (terminal 60)
- Meter (-) → BK/Y lead (terminal 52)

Connections for Stick Coil #3

- Meter (+) → BK/W lead (terminal 45)
- Meter (-) → BK/Y lead (terminal 52)

Connections for Stick Coil #4

- Meter (+) → BK/O lead (terminal 58)
- Meter (-) → BK/Y lead (terminal 52)

- Measure the input voltage to each primary winding of the stick coils with the engine stopped, and with the connectors joined.
- Turn the ignition switch ON.

Input Voltage at ECU

Standard: Battery Voltage

- ★ If the reading is out of the standard, check the wiring (see wiring diagram in this section).
- ★ If the reading is good, the input voltage is normal. Crank the engine, and check the peak voltage of the stick coils (see Stick Coil Primary Peak Voltage Inspection in the Electrical System chapter) in order to check the primary coils.

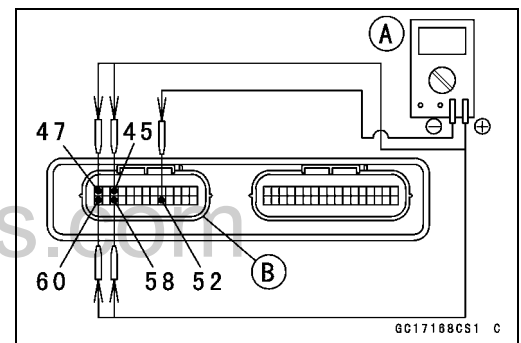

Stick Coils #1, #2, #3, #4: (Service Code 51, 52, 53, 54)

Stick Coil Circuit

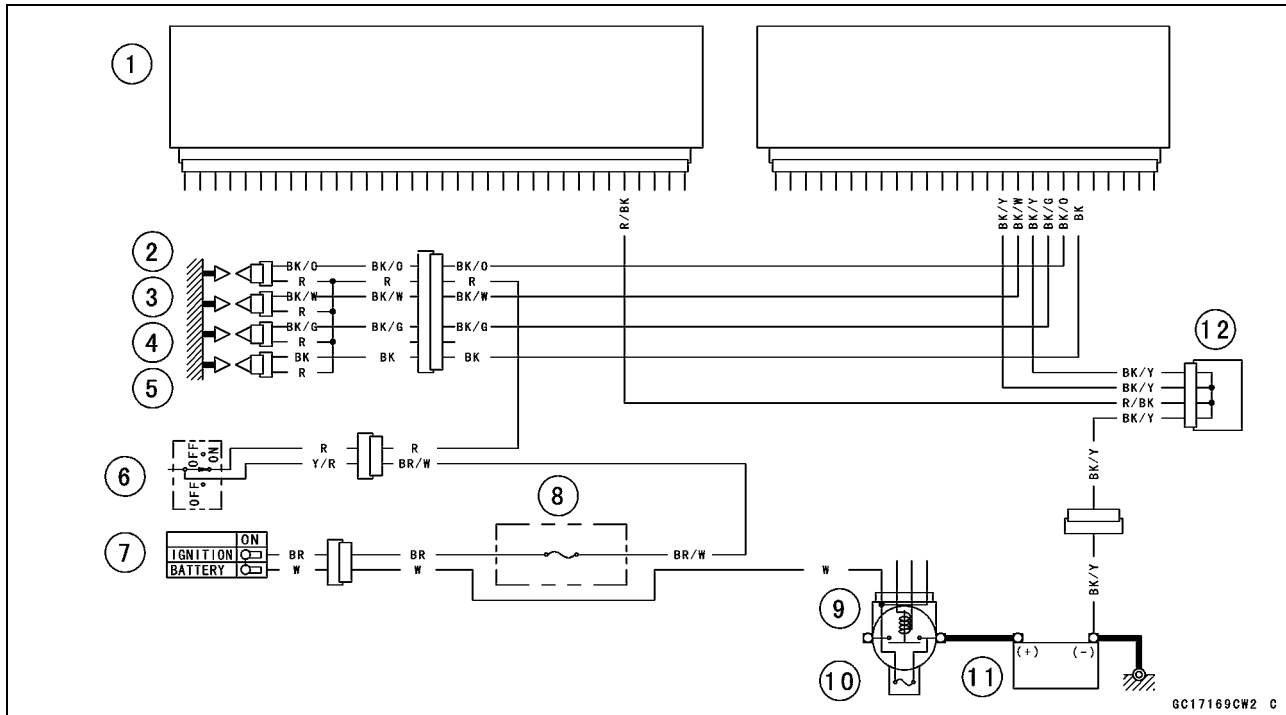

GC17169CW2 C

- 1. ECU
- 2. Stick Coil #4
- 3. Stick Coil #3
- 4. Stick Coil #2
- 5. Stick Coil #1
- 6. Engine Stop Switch
- 7. Ignition Switch
- 8. Ignition Fuse 10 A
- 9. Starter Relay
- 10. Main Fuse 30 A
- 10. Fuse Box
- 11. Battery 12 V 10 Ah
- 12. Joint Connector 3

Subthrottle Valve Actuator (Service Code 62)**Subthrottle Valve Actuator Removal****CAUTION**

Do not remove the subthrottle valve actuator [A] since it has been adjusted and set with precision at the factory.

Never drop the actuator, especially on a hard surface. Such a shock to the actuator can damage it.

**Subthrottle Valve Actuator Inspection**

- Remove the air cleaner housing (see Air Cleaner Housing Removal).
- Turn the ignition switch ON.
- Check to see that all subthrottle valves [A] open and close smoothly.
- ★ If the subthrottle valves do not operate, check the actuator internal resistance (see Resistance Inspection).

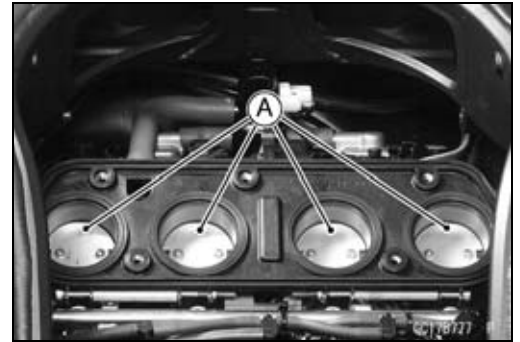
**Resistance Inspection**

- Turn the ignition switch OFF.
- Disconnect the subthrottle valve actuator connector [A].



- Connect a digital meter to the connector [A].
- Measure the subthrottle valve actuator resistance.

Subthrottle Valve Actuator Resistance

Connections: Y lead [1] ↔ P lead [2]

BK lead [3] ↔ G lead [4]

Standard: About 5 ~ 7 Ω

- ★ If the reading is out of the range, replace the throttle body assy (see Throttle Body Assy section).
- ★ If the reading is within the range, check the input voltage (see Input Voltage Inspection in this section).

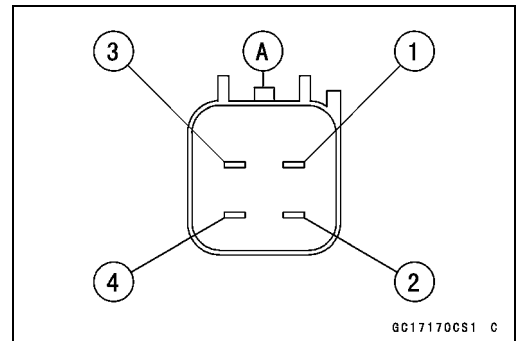

Subthrottle Valve Actuator (Service Code 62)**Input Voltage Inspection****NOTE**

○ Be sure the battery is fully charged.

- Turn the ignition switch OFF.
- Connect the peak voltage adapter [A] and a digital meter [B] to the connector [C], using the needle adapter set [D].

Special Tools - Peak Voltage Adapter: 57001-1415

Type: KEK-54-9-B

Needle Adapter Set: 57001-1457

**Subthrottle Valve Actuator Input Voltage
Connections to Harness Connector**

- (I) Meter (+) → BK/BL lead [1]
Meter (-) → Battery (-) Terminal
- (II) Meter (+) → G lead [2]
Meter (-) → Battery (-) Terminal
- (III) Meter (+) → Y/BK lead [3]
Meter (-) → Battery (-) Terminal
- (IV) Meter (+) → P lead [4]
Meter (-) → Battery (-) Terminal

- Measure the actuator input voltage with the engine stopped, and with the connector joined.
- Turn the ignition switch ON.

Input Voltage

Standard: About DC 10.5 ~ 12.5 V

- ★ If the reading is out of the range, check the wiring to ECU (see wiring diagram in this section).
- ★ If the wiring is good, replace the ECU (see ECU section).

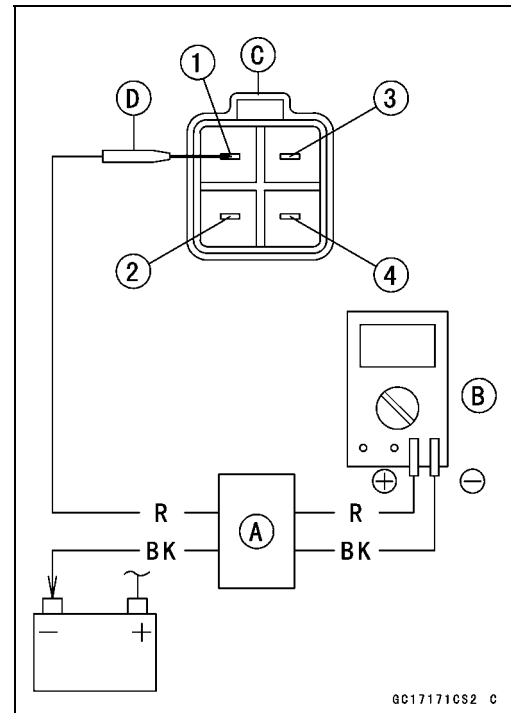

Exhaust Butterfly Valve Actuator (Service Code 63)

Exhaust Butterfly Valve Actuator Removal

- Remove the seat cover (see Seat Cover Removal in the Frame chapter)
- Slide the dust covers [A].
- Loosen the locknuts [B], and turn the adjuster to give the cable plenty of play [C].

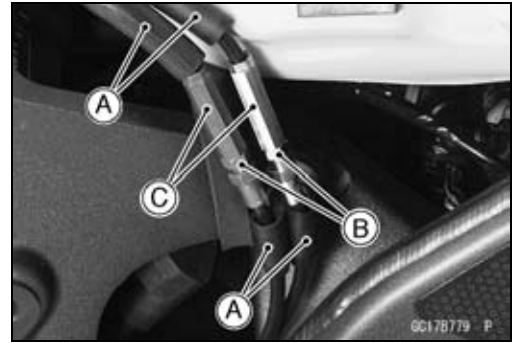

- Remove:
Clamp [A]
Exhaust Butterfly Valve Cables [B]
Connectors [C]

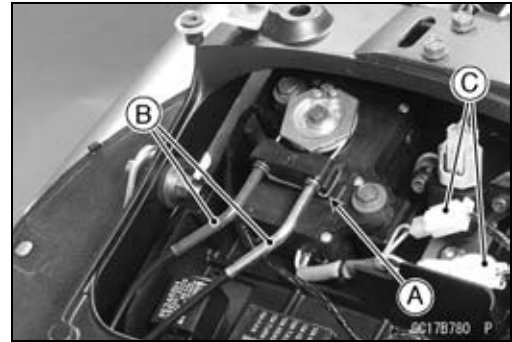

- Remove:
Bolts [A]
Exhaust Butterfly Valve [B]

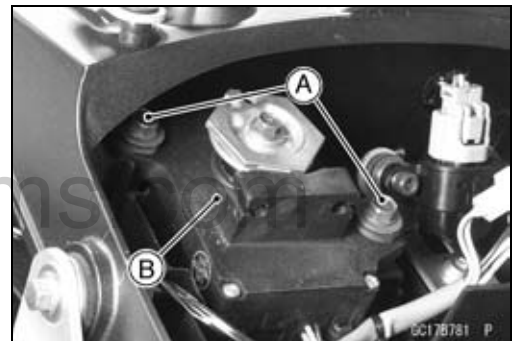

- Remove exhaust butterfly valve actuator pulley [A].
○ Hold the pulley with a suitable tool.

www.zxforums.com

CAUTION

If the pulley bolt is removed without holding, the actuator damage will occur.



Exhaust Butterfly Valve Actuator Installation

- Install the pulley [A] on the actuator.
- Hold the pulley with a suitable tool [B] and tighten the bolt.
Torque - Exhaust Butterfly Valve Actuator Pulley Bolt: 5.0 N·m (0.50 kgf·m, 44 in·lb)

CAUTION

If the pulley bolt is tightened without holding, the actuator damage will occur.

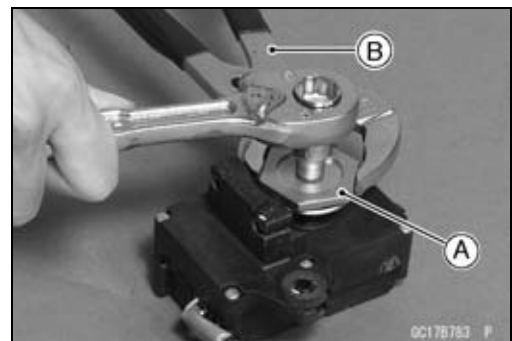

Exhaust Butterfly Valve Actuator (Service Code 63)

- Confirm the pulley angle [A] ($41.7^{\circ} \pm 7^{\circ}$) as shown. It is original position of the pulley [B].
- ★ If the angle is not within the specified angle, adjust the actuator as follows.
 - Connect the actuator connectors.
 - Turn the ignition switch ON.
 - Confirm the pulley turns clockwise and then counterclockwise, and clockwise again
 - Turn the ignition switch OFF.
 - Confirm the pulley turns counterclockwise little.
 - The position is original position of the pulley.
- ★ If the position is not within the specified angle above, replace the exhaust butterfly valve actuator.

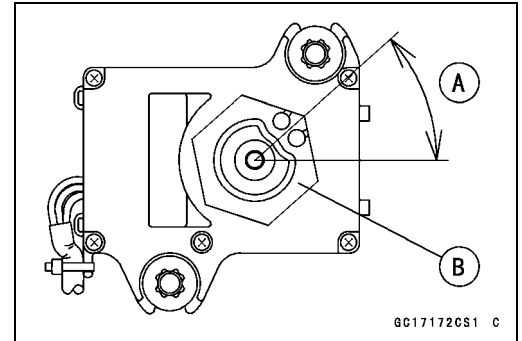

- Install the actuator [A] on the rear fender.
 - Nuts [B]
 - Washers [C]
 - Exhaust Butterfly Valve Actuator Mounting Bolts [D]
- Tighten:
 - Torque - Exhaust Butterfly Valve Actuator Mounting Bolts:**
0.8 N·m (0.08 kgf·m, 7 in·lb)
- Install the close cable first and then open cable (see Exhaust Butterfly Valve Cable Installation in the Engine Top End chapter)

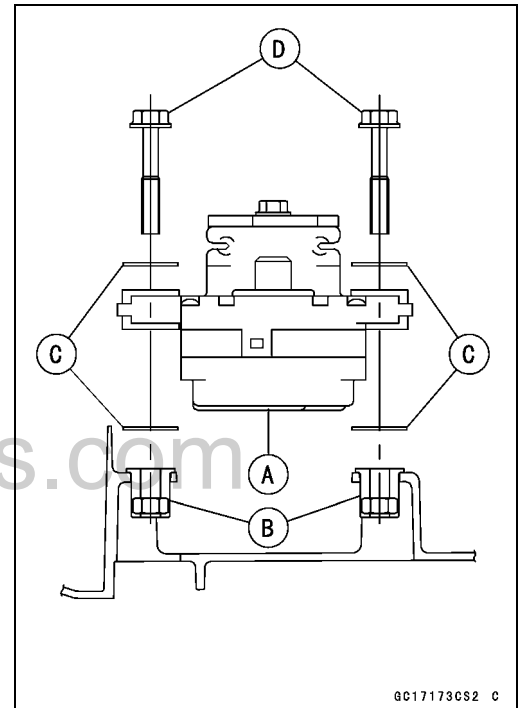
**Exhaust Butterfly Valve Actuator Inspection**

- Remove the seat cover (see Seat Cover Removal in the Frame chapter).
- Turn the ignition switch ON.
- Check to see the pulley [A] clockwise [B] and counterclockwise [C] smoothly.
- ★ If the pulley does not operate, check the exhaust butterfly valve actuator sensor output voltage (see Output Voltage Inspection).

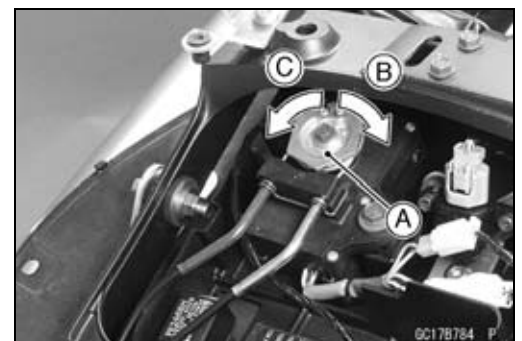

Exhaust Butterfly Valve Actuator (Service Code 63)

Output Voltage Inspection

- Remove the seat cover (see Seat Cover Removal in the Frame chapter).
- Turn the ignition switch ON and wait until the pulley stops.
- Turn the ignition switch OFF and wait until the pulley stops. It is original position of the pulley.
- Measure the output voltage at the 3 pins connector of the exhaust butterfly valve actuator [A] when the pulley is original position as follows.
- Disconnect:
 - 2 pins Connector [B]
 - 3 pins Connector [C]
- Connect the adapter [D] between the 3 pins connectors and digital meter [E].
Main Harness [F]

Special Tool - Throttle Sensor Setting Adapter #1: 57001-1400

Connections to Adapter

- Meter (+) → BL (actuator Y) lead [G]
- Meter (-) → BK/BL (actuator BK) lead [H]

- Turn the ignition switch ON.

Actuator Output Voltage (Pulley Original Position)

Standard: 3.46 ~ 3.76 V

★ If the output voltage is out of the standard, remove the actuator and check the original position of the pulley (see Exhaust Butterfly Valve Actuator Installation).

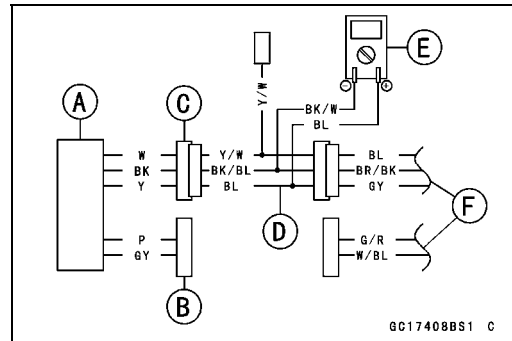
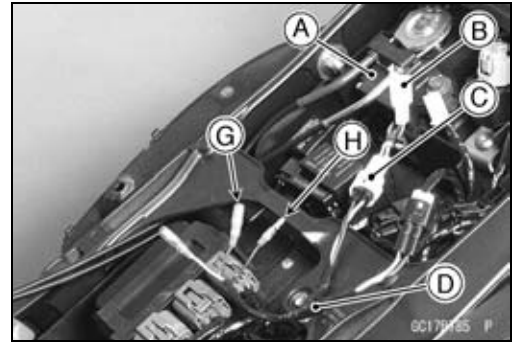

Exhaust Butterfly Valve Actuator Circuit

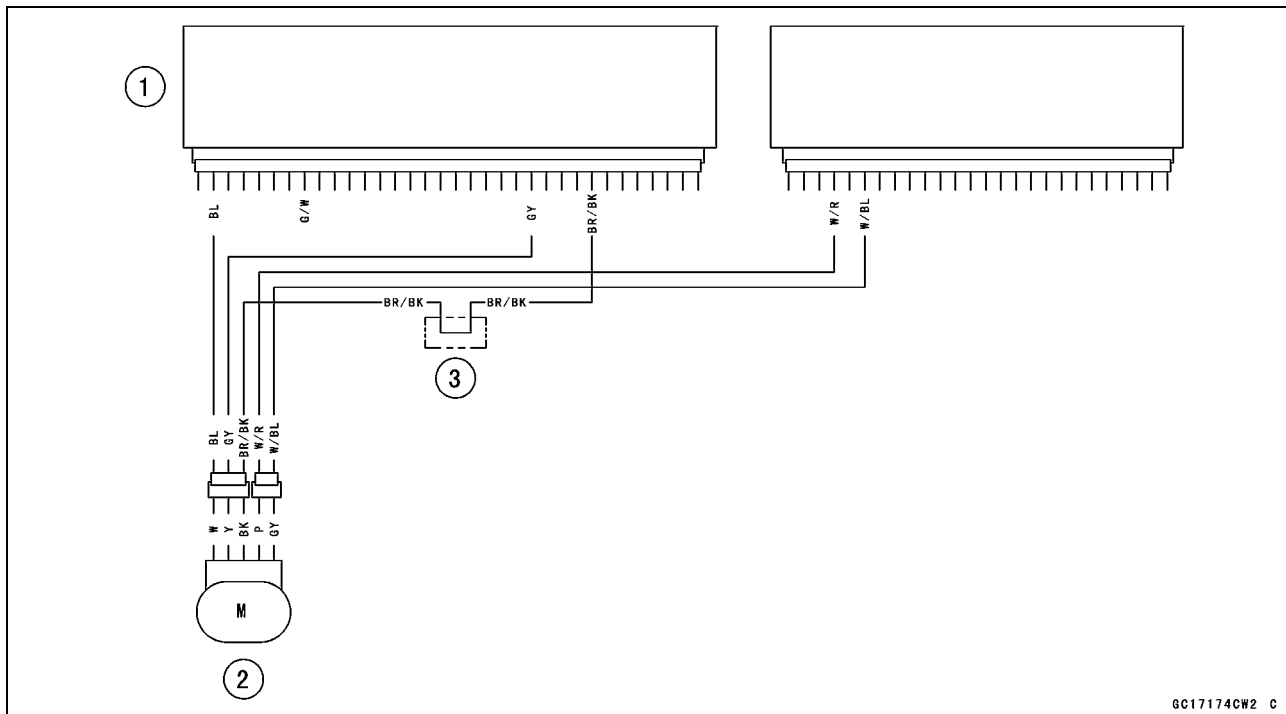

1. ECU
2. Exhaust Butterfly Valve Actuator
3. Water-proof Joint 2

Oxygen Sensor Heaters (#1 and/or #2: Service Code 67) - Europe Models**Oxygen Sensor Heaters Removal/Installation**

The oxygen sensor heater is built in the oxygen sensor. So, the heater itself can not be removed. Remove the oxygen sensors (see Oxygen Sensor Removal in the Electrical System chapter).

Oxygen Sensor Heaters Inspection**NOTE**

- The oxygen sensor itself is the same for #1 [A] and #2 [B], but wiring of the main harness side is different.

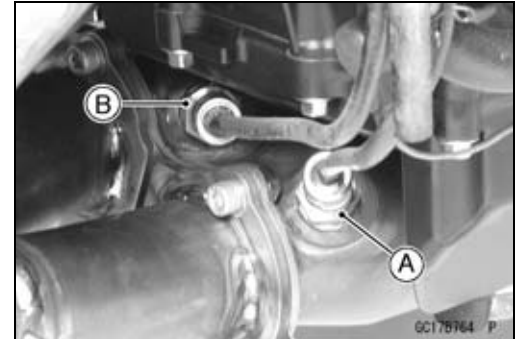

- Turn the ignition switch OFF.
- Remove the left middle fairing (see Middle Fairing Removal in the Frame chapter).
- Disconnect the oxygen sensor lead connectors [A].



- Set the hand tester [A] to the $\times 1 \Omega$ range and connect it to the terminals in each oxygen sensor lead connectors [B].
White [C]
White [D]

Special Tool - Hand Tester: 57001-1394

Oxygen Sensor Heaters Resistance

Standard: About 8Ω at 20°C (68°F)

- ★ If the tester reading is far out of the specified, replace the oxygen sensor.

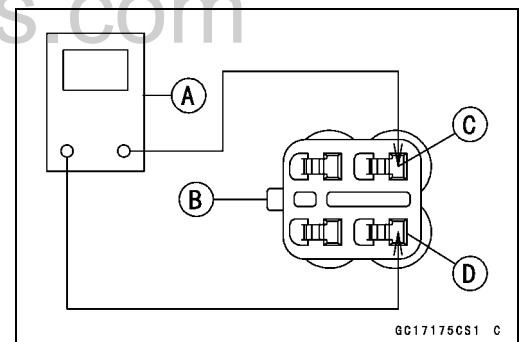

Oxygen Sensor Heaters (#1 and/or #2: Service Code 67) - Europe Models

★ If the tester reading is specified, check the power source voltage inspection.

NOTE

○ Be sure the battery is fully charged.

- Connect a digital meter [A] to each oxygen sensor connector [B], using the needle adapter [C].

Special Tool - Needle Adapter Set: 57001-1457

Oxygen Sensor Heaters Power Source Voltage Connections to Oxygen Sensor Connector

Tester (+) → W (main harness side LG) lead [D]

Tester (-) → Battery (-) Terminal [E]

Oxygen Sensor #1 [F]

Oxygen Sensor #2 [G]

- Measure the power source voltage with the engine stopped, and with the oxygen sensor connector joined.
- Turn the ignition switch ON.

Power Source Voltage at Sensor Connector

Standard: Battery Voltage

★ If the reading is incorrect, check the following.

Battery (see Charging Condition Inspection in the Electrical System chapter)

Main Fuse 30 A (see Fuse Inspection in the Electrical System chapter)

Oxygen Sensor Heater Fuse 10 A (see Fuse Inspection in the Electrical System chapter)

★ If the reading is good, the power source voltage is normal, inspect the Red lead between the oxygen sensor connector and the ECU for continuity, using the following diagram.

★ If the wiring is good, inspect the ECU for its ground, and power supply (see ECU Power Supply Inspection). If the ground and power supply are good, replace the ECU (see ECU section).

- Remove the needle adapter set, and apply silicone sealant to the connector for water proofing.

Sealant - Kawasaki Bond (Silicone Sealant): 56019-120

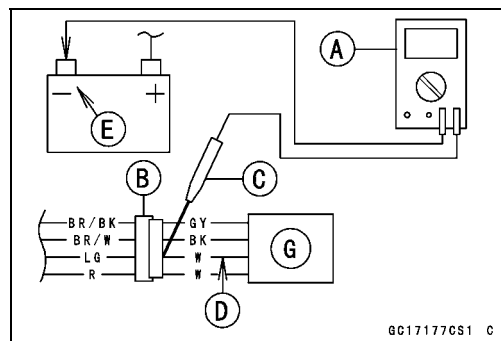
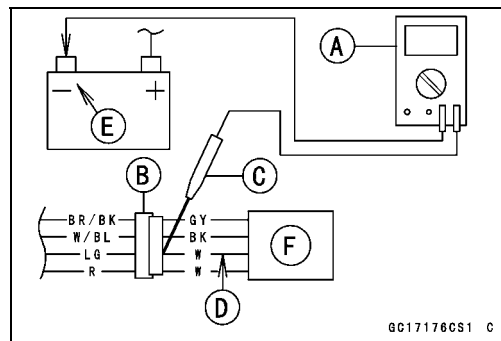

Oxygen Sensor Heaters (#1 and/or #2: Service Code 67) - Europe Models

Oxygen Sensor Circuit

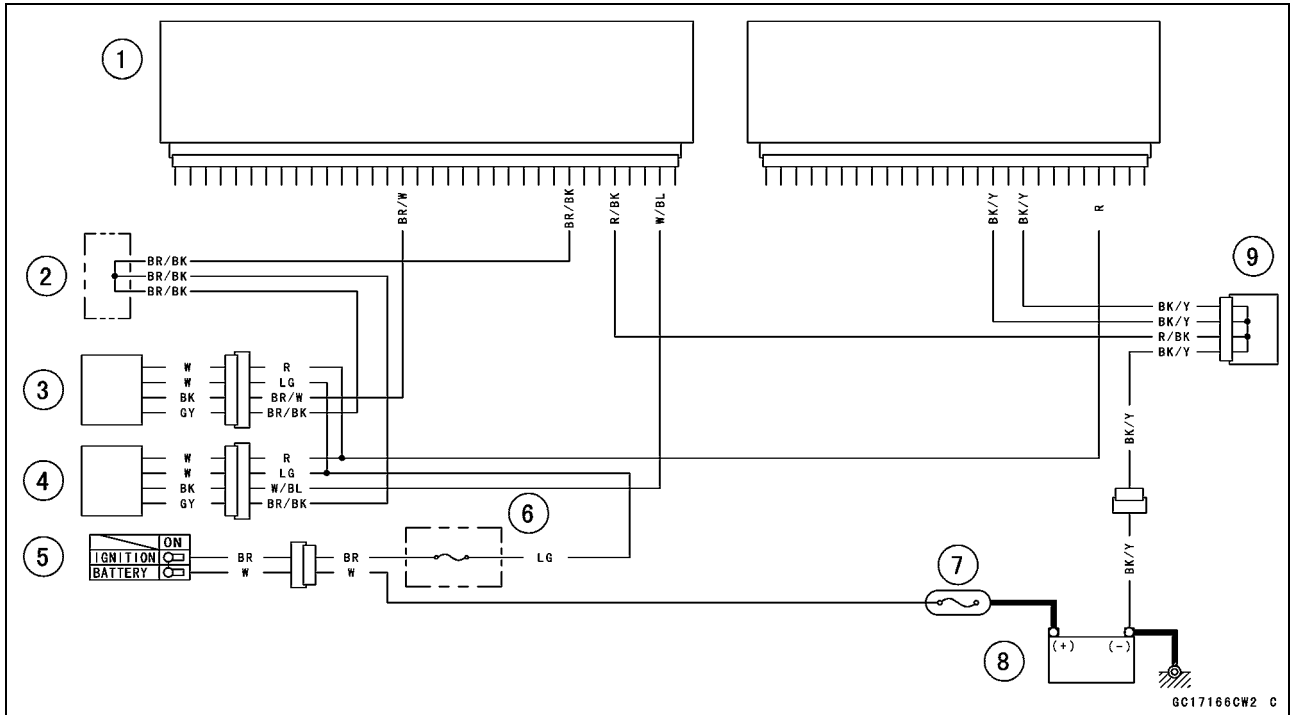

1. ECU
2. Water-proof Joint 2
3. Oxygen Sensor #2
4. Oxygen Sensor #1
5. Ignition Switch
6. Oxygen Sensor Heater Fuse 10 A
7. Main Fuse 30 A
8. Battery 12 V 10 Ah
9. Joint Connector 3

ECU Main Relay (Service Code 75)

ECU Main Relay Inspection

- The ECU main relay function is included in the ECU [A].
So, the ECU main relay function cannot inspect.
- When the service code 75 is displayed on the LCD, replace the ECU (see ECU section!).

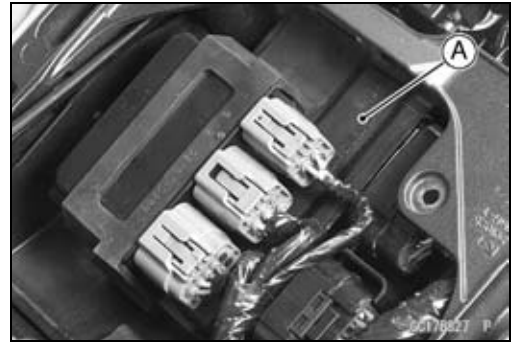

Oxygen Sensor #2-not activated (Service Code 83) - Europe Models**Oxygen Sensor #2 Removal/Installation**

- Refer to the Oxygen Sensor Removal (Europe Models) in the Electrical System chapter (see Oxygen Sensor Removal (Europe Models) in the Electrical System chapter).

Oxygen Sensor #2 Inspection**NOTE**

- *The oxygen sensor itself is the same for #1 [A] and #2 [B], but wiring of the main harness side is different.*

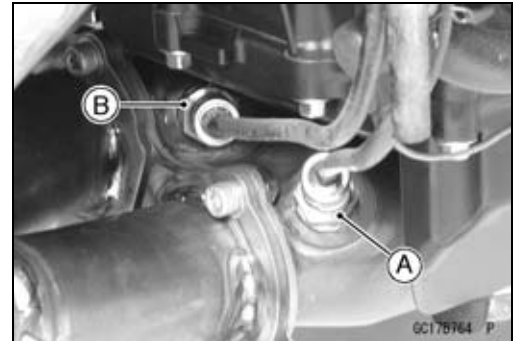

- Warm up the engine thoroughly until the radiator fan starts.
- Turn the ignition switch OFF.
- Remove left middle fairing (see Middle Fairing Removal in the Frame chapter).
- Connect a digital meter [A] to the oxygen sensor #2 lead connector [B] (sensor side), using the needle adapter set [C].



Special Tool - Needle Adapter Set: 57001-1457

Oxygen Sensor #2 Output Voltage**Connections to Oxygen Sensor Connector**

Meter (+) → BK lead

Meter (-) → GY lead

- Remove:
 - Fuel Tank (see Fuel Tank Removal)
 - Air Cleaner Housing (see Air Cleaner Housing Removal)
- Separate the hoses [A] from the air suction valve covers [B].

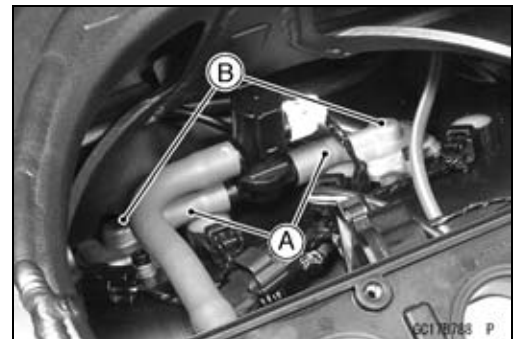

- Install the suitable plugs [A] on the fittings of the air suction valve covers [B], and shut off the secondary air.

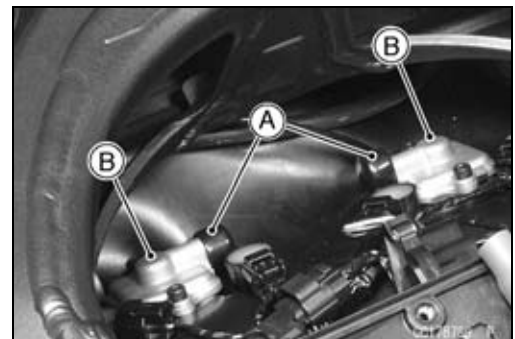

Oxygen Sensor #2-not activated (Service Code 83) - Europe Models

- Connect the following parts temporary.
Fuel Pump Lead Connector [A]
Extension Tube [B]
Special Tool - Extension Tube: 57001-1578

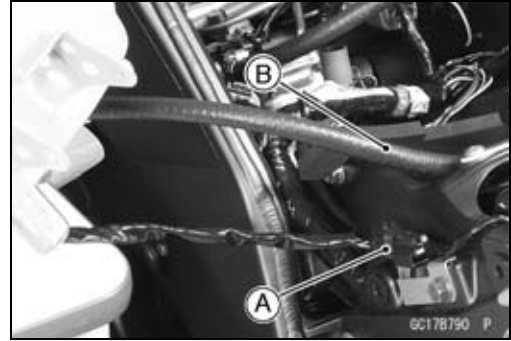

- Turn the ignition switch ON.
- Start the engine, and let it idle.
- Measure the output voltage of the sensor with the connector joined.

Oxygen Sensor Output Voltage (with Plugs)

Standard: 0.45 ~ 2.5 V

- Next, remove the plugs from the fittings [A] with idling.

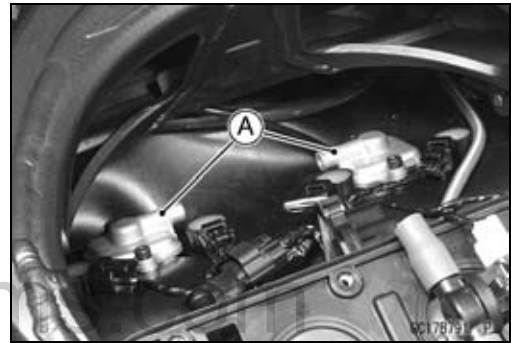

- Measure the output voltage of the sensor with the connector joined.

Oxygen Sensor #2 Output Voltage (without Plugs)

Standard: 0.05 ~ 0.45 V

- ★ If the reading is within range (with plugs: 0.45 ~ 2.5 V, without plugs: 0.05 ~ 0.45 V), the oxygen sensor is good.
- ★ If the reading is without range, replace the oxygen sensor.
- Remove the needle adapter set, and apply silicone sealant to the seals of the connector for waterproofing.

Sealant - Kawasaki Bond (Silicone Sealant): 56019-120

Oxygen Sensor #2-not activated (Service Code 83) - Europe Models

Oxygen Sensor Circuit

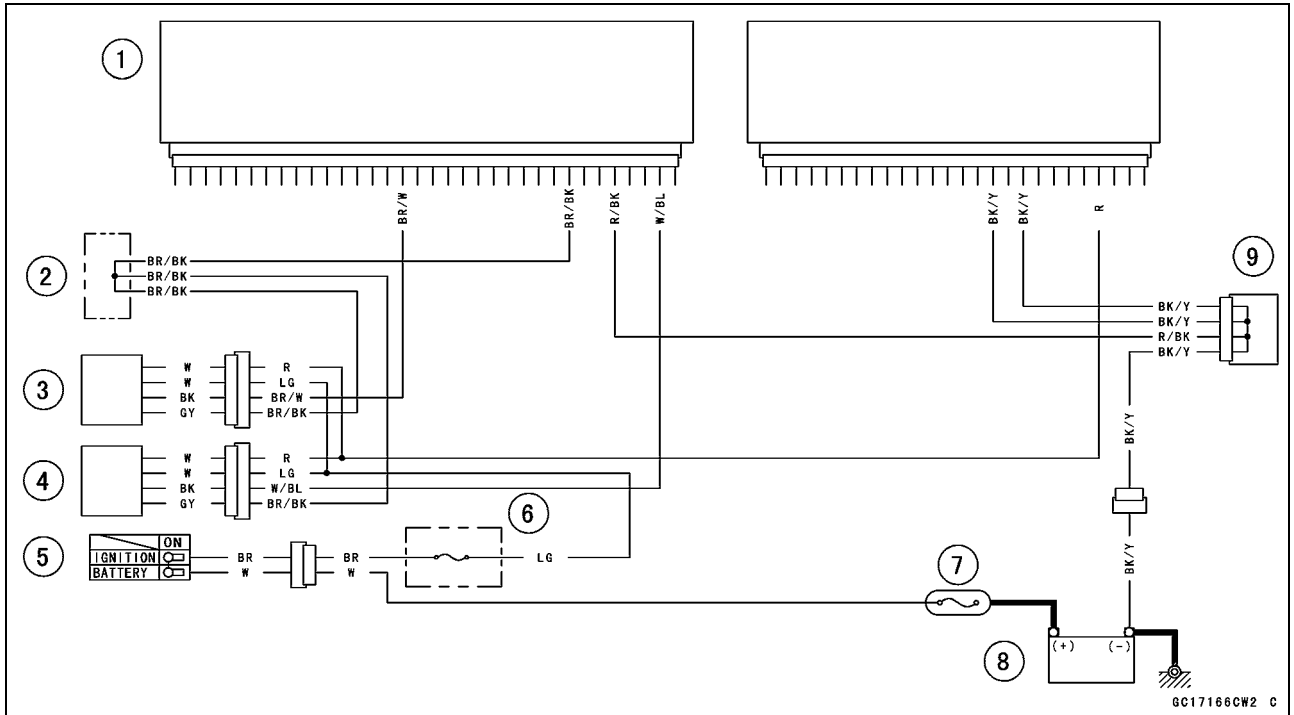

- 1. ECU
- 2. Water-proof Joint 2
- 3. Oxygen Sensor #2
- 4. Oxygen Sensor #1
- 5. Ignition Switch
- 6. Oxygen Sensor Heater Fuse 10 A
- 7. Main Fuse 30 A
- 8. Battery 12 V 10 Ah
- 9. Joint Connector 3

ECU

CAUTION

Never drop the ECU, especially on a hard surface. Such a shock to the ECU can damage it.

ECU Identification

Most countries have their own regulations, so each ECU has different characteristics. So, do not confuse ECU with each other and use only the ECU for your model. Otherwise, the motorcycle cannot clear the regulation.

ECU Identification

Part Number [A]	Specification
21175-0079	Europe, WVTA, Full, H, with Immobilizer
	U.K., WVTA, Full, H, with Immobilizer
21175-0082	U.S.A (except California), without Immobilizer
	Canada, without Immobilizer
21175-0083	U.S.A (California), without Immobilizer
21175-0093	Malaysia, with Immobilizer
21175-0094	Australia, with Immobilizer
21175-0095	France, WVTA, 78.2, H, with Immobilizer

Full: Full Power

H: Honeycomb Type Catalyst

78.2: Maximum Horsepower 78.2 kW (106.3 PS)

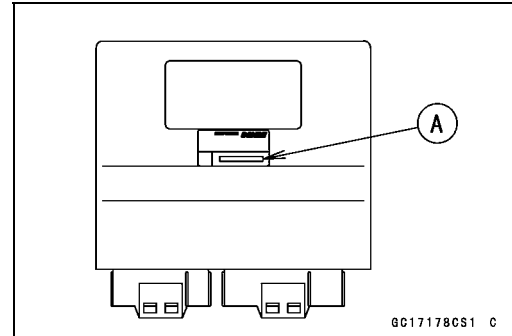

ECU Removal

- Remove the front seat (see Front Seat Removal in the Frame chapter).
- Lift up the ECU [A] and relay box [B] with rubber protector [C].

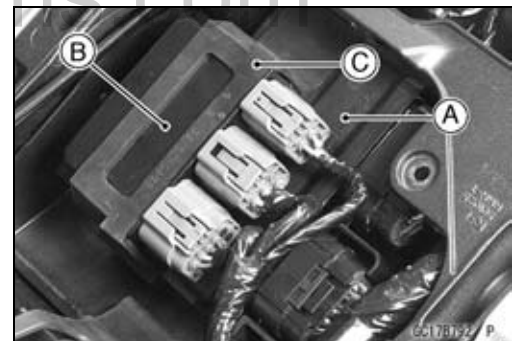

- Remove:
 - ECU Connectors [A]
 - ECU [B]
- Refer to the Immobilizer System Parts Replacement in the Electrical System chapter for the immobilizer models (see Immobilizer System Parts Replacement in the Electrical System chapter).

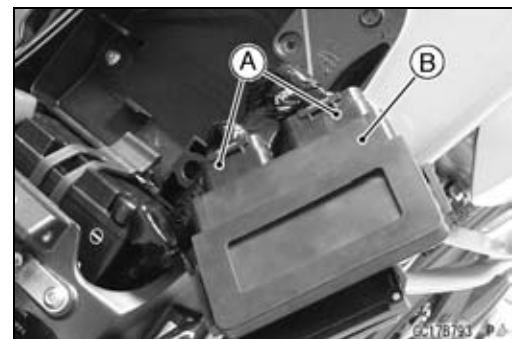

ECU**ECU Installation**

- Install:
 - ECU [A] (In rubber protector [B])
 - ECU Connectors

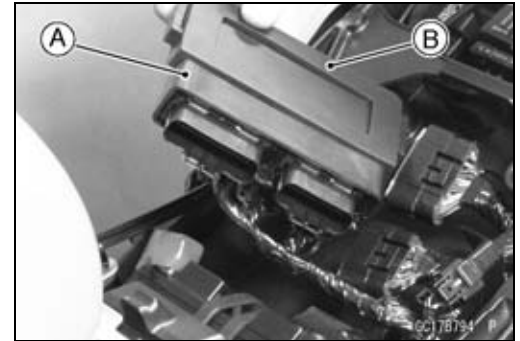

- Insert the slits of the rubber protector to the projections [A] of the rear fender front.

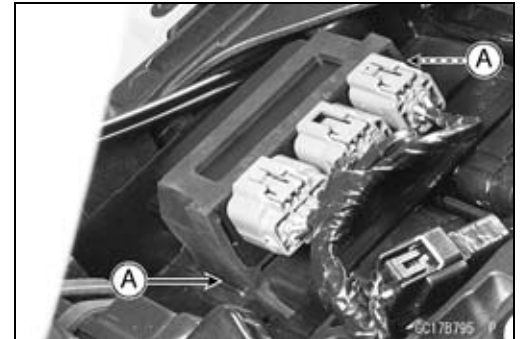
**ECU Power Supply Inspection**

- Remove the ECU (see ECU Removal).
- Visually inspect the terminals [A] of the ECU connectors.
- ★ If the connector is clogged with mud or dust, blow it off with compressed air.
- ★ Replace the main harness if the terminals of the main harness connectors are cracked, bent, or otherwise damaged.
- ★ Replace the ECU if the terminals of the ECU connectors are cracked, bent, or otherwise damaged.

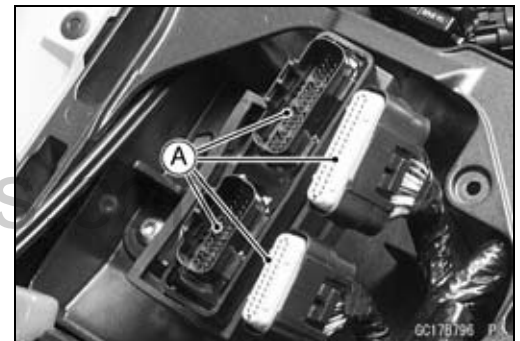

- With the ECU connectors [B] connected, check the following ground lead for continuity with the ignition switch OFF, using a digital meter [A] and needle adapter set.
 - Battery [C]

Special Tool - Needle Adapter Set: 57001-1457

ECU Grounding Inspection

17, 39, or 52 Terminal ↔ Battery (-) Terminal: 0 Ω
 Engine Ground ↔ Battery (-) Terminal: 0 Ω

- ★ If no continuity, check the connector, the engine ground lead, or main harness, and repair or replace them if necessary.

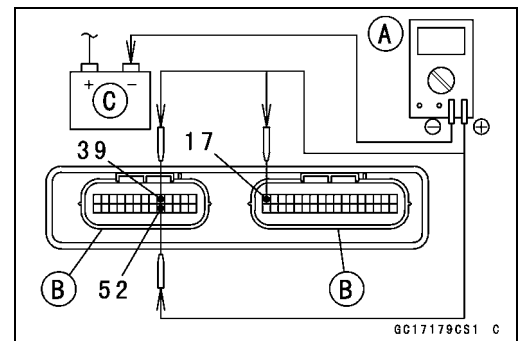

ECU

- Check the ECU power source voltage with a digital meter [A].
- Position the terminal in accordance with terminal numbers of ECU connectors [B] in the figure.
Battery [C]

ECU Power Source Inspection**Tester**

- Connections:**
- between 33 (BR) Terminal and Battery (-) Terminal
 - between 15 (W/BK) Terminal and Battery (-) Terminal
 - between 32 (W/BK) and Battery (-) Terminal

- Ignition Switch OFF:**
- 33 (BR) Terminal, 0 V
 - 15 (W/BK) Terminal, Battery Voltage
 - 32 (W/BK) Terminal, Battery Voltage

- Ignition Switch ON:**
- 33 (BR) Terminal, Battery Voltage
 - 15 (W/BK) Terminal, Battery Voltage
 - 32 (W/BK) Terminal, Battery Voltage

- ★ If the tester does not read as specified, check the following.

- Power Source Wiring (see wiring diagram in this section)
- Main Fuse 30 A (see Fuse Inspection in the Electrical System chapter)
- ECU Fuse 15 A (see ECU Fuse Inspection)

- ★ If the wiring and fuse are good, replace the ECU (see ECU section).

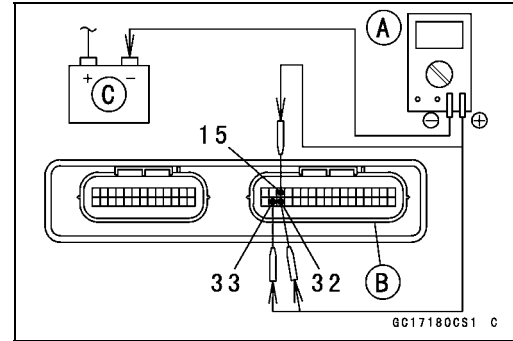

ECU

ECU Power Source Circuit

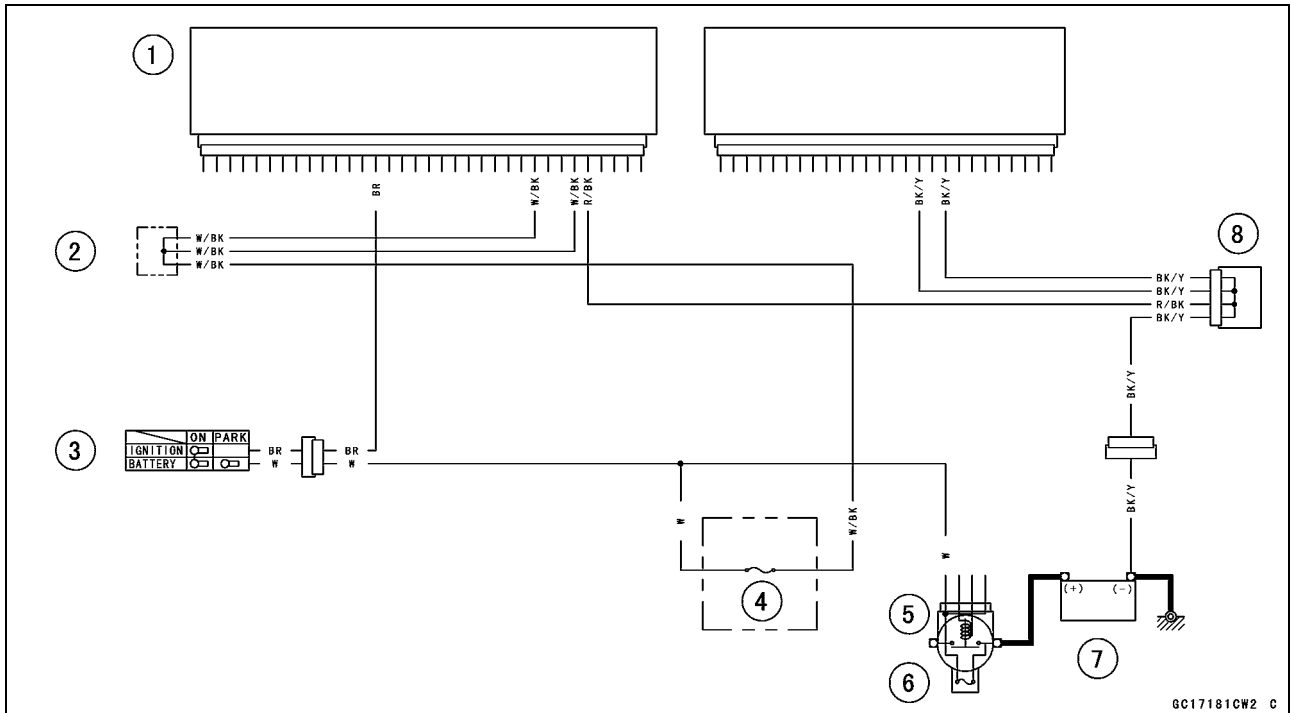

- 1. ECU
- 2. Water-proof Joint 1
- 3. Ignition Switch
- 4. ECU Fuse 15 A
- 5. Starter Relay
- 6. Main Fuse 30 A
- 7. Battery 12 V 10 Ah
- 8. Joint Connector 3

DFI Power Source

ECU Fuse Removal

- Refer to the 15 A ECU Fuse Removal in the Electrical System chapter (see 15 A ECU Fuse Removal in the Electrical System chapter).

ECU Fuse Installation

- ★ If a fuse fails during operation, inspect the DFI system to determine the cause, and then replace it with a new fuse of proper amperage.
- Refer to the Fuse installation in the Electrical System chapter (see Fuse Installation in the Electrical System chapter).

ECU Fuse Inspection

- Refer to the Fuse Inspection in the Electrical System chapter (see Fuse Inspection in the Electrical System chapter).

www.zxforums.com

Warning Indicator Light (LED)

Light (LED) Inspection

- The warning indicator light (LED) [A] is used for the FI indicator, immobilizer indicator (immobilizer models) and oil pressure warning indicator.
- In this model, the warning indicator light (LED) (FI/immobilizer) blink by the special signal sent from the ECU.
- Refer to the warning indicator light (LED) (oil pressure warning) inspection procedure (see Electronic Combination Meter Unit Inspection in the Electrical System chapter) for the warning indicator light (LED) (FI/immobilizer) inspection.

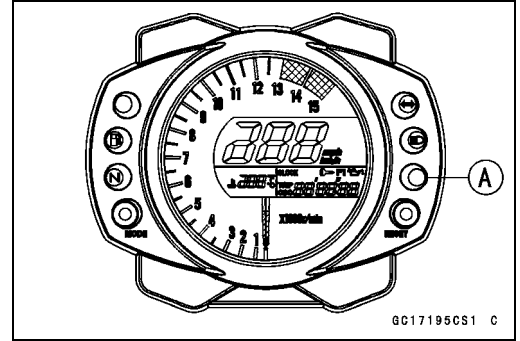

Warning Indicator Light (LED) (FI/Immobilizer) Circuit

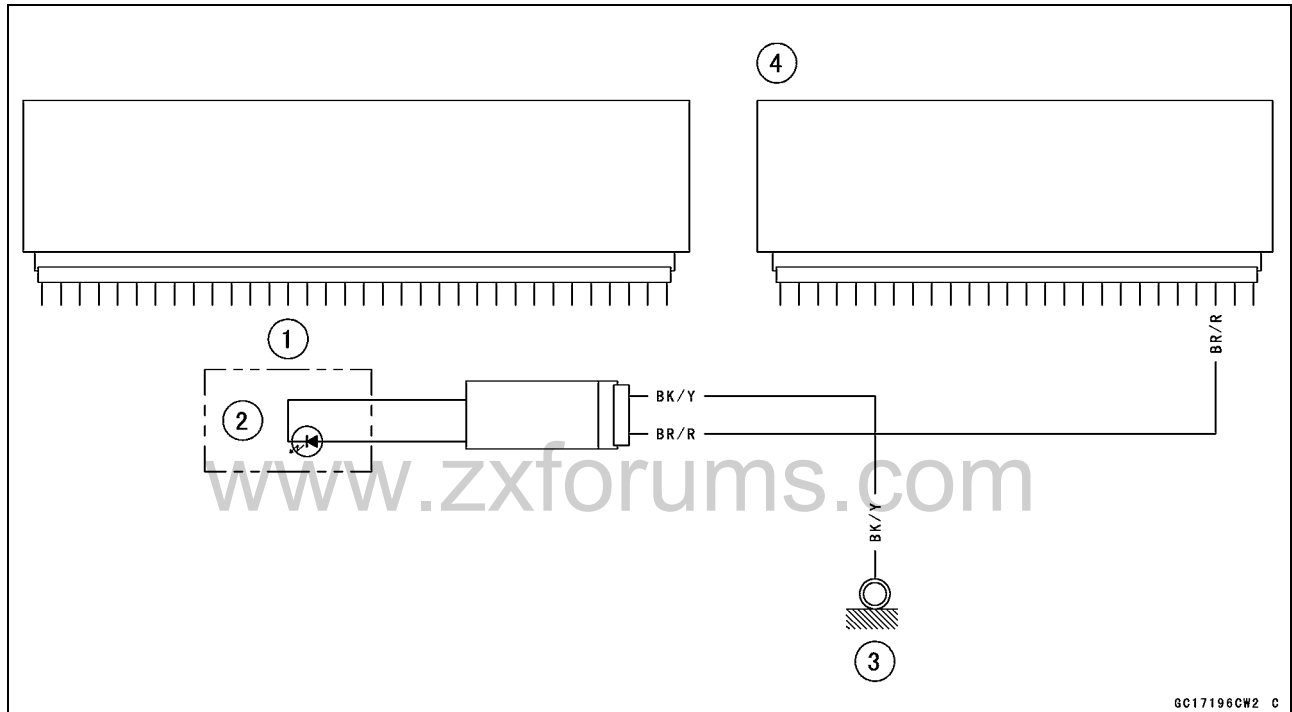

1. Meter Unit
2. Warning Indicator Light (LED)
3. Frame Ground
4. ECU

Fuel Line

Fuel Pressure Inspection

NOTE

○ Be sure the battery is fully charged.

- Remove:
 - Front Seat (see Front Seat Removal in the Frame chapter)
 - Steering Damper (see Steering Damper Removal in the Steering chapter)
 - Fuel Tank Bolts [A]
- Be sure to place a piece of cloth around the fuel supply pipe of the throttle body assy and fuel pump.
- Remove the fuel hose (see Fuel Tank Removal).

⚠ WARNING

Be prepared for fuel spillage; any spilled fuel must be completely wiped up immediately.

When the fuel hose is disconnected, fuel spills out from the hose and the pipe because of residual pressure. Cover the hose connection with a piece of clean cloth to prevent fuel spillage.

- Install the fuel pressure gauge adapter [A] and fuel hoses (Special Tool: 57001-1607) [B] between the fuel supply pipes of the fuel pump and throttle body assy.
- Connect the pressure gauge [C] to the fuel pressure gauge adapter.

Special Tools - Oil Pressure Gauge, 5 kgf/cm²: 57001-125
 Fuel Pressure Gauge Adapter: 57001-1593
 Fuel Hose: 57001-1607

⚠ WARNING

Do not try to start the engine with the fuel hoses disconnected.

- Turn the ignition switch ON. The fuel pump will turn for 4 seconds, and then stop.

CAUTION

Do not drive the fuel pump 4 seconds or more without the fuel in the fuel tank. If the fuel pump is driven without the fuel, it may be damaged.

- Measure the fuel pressure with the engine stopped.

Fuel Pressure

right after Ignition Switch ON, with pump running:

Standard: 304 kPa (3.1 kgf/cm², 44 psi)

after 4 seconds from Ignition Switch ON, with pump stopped:

Standard: 280 kPa (2.9 kgf/cm², 41 psi), residual fuel pressure

The system should hold the residual pressure about 30 seconds.

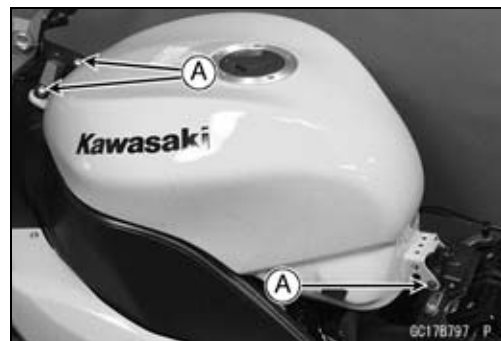

Fuel Line

- Start the engine, and let it idle.
- Measure the fuel pressure with the engine idling.

Fuel Pressure (idling)

Standard: 304 kPa (3.1 kgf/cm², 44 psi)

NOTE

- *The gauge hand will fluctuate. Read the pressure at the average of the maximum and minimum indications.*
- ★ If the fuel pressure is much higher than the specified, replace the fuel pump (see Fuel Pump section).
- ★ If the fuel pressure is much lower than specified, check the following.
 - Fuel Line Leakage
 - Amount of Fuel Flow (see Fuel Flow Rate Inspection)
- ★ If the fuel pressure is much lower than specified, and if inspection above checks out good, replace the throttle body assy, or the fuel pump and measure the fuel pressure again (see appropriate sections).
- Remove the fuel pressure gauge, hoses and adapter.
- Install:
 - Fuel Hose (see Fuel Hose Replacement in the Periodic Maintenance chapter)
 - Fuel Tank (see Fuel Tank Installation)

Fuel Flow Rate Inspection

NOTE

- *Be sure the battery is fully charged.*

⚠ WARNING

Gasoline is extremely flammable and can be explosive under certain conditions. Make sure the area is well-ventilated and free from any source of flame or sparks; this includes any appliance with a pilot light. Do not smoke. Turn the ignition switch OFF. Be prepared for fuel spillage; any spilled fuel must be completely wiped up immediately.

- Turn the ignition switch and engine stop switch OFF.
- Wait until the engine cools down.
- Prepare a fuel hose (Special Tool: 57001-1607) and a measuring cylinder.

Special Tool - Fuel Hose: 57001-1607

- Remove:
 - Front Seat (see Front Seat Removal in the Frame chapter)
 - Steering Damper (see Steering Damper Removal in the Steering chapter)
 - Fuel Tank Bolts [A]

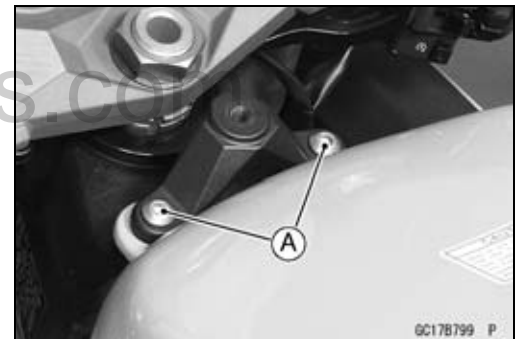

Fuel Line

- Open the fuel tank cap [A] to lower the pressure in the tank.
- Be sure to place a piece of cloth around the fuel supply pipe of the fuel pump.
- Remove the fuel hose from the fuel pump (see Fuel Tank Removal).

⚠ WARNING

Be prepared for fuel spillage; any spilled fuel must be completely wiped up immediately. When the fuel hose is disconnected, fuel spills out from the hose and the pipe because of residual pressure. Cover the hose connection with a piece of clean cloth to prevent fuel spillage.

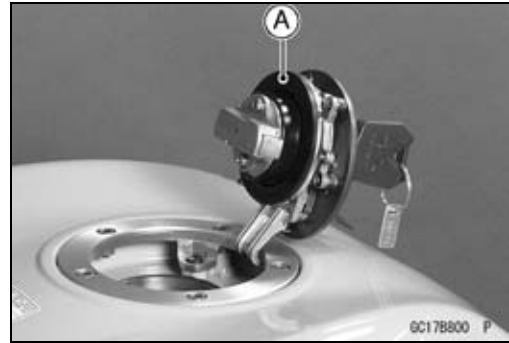

- Connect the prepared fuel hose [A] to the fuel supply pipe of the fuel pump.
- Secure the fuel hose with a clamp.
- Insert the fuel hose into the measuring cylinder [B].

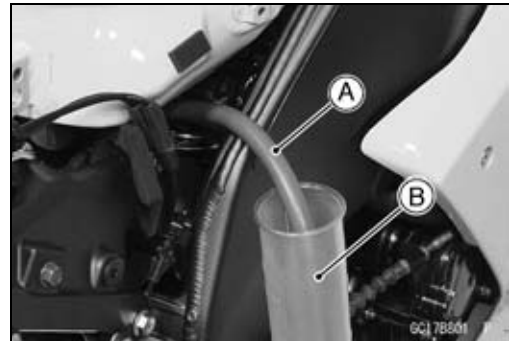

⚠ WARNING

Wipe off spilled out fuel immediately. Be sure to hold the measuring cylinder vertical.

- Close the fuel tank cap.
- With the engine stopped, turn the ignition switch ON. The fuel pump should operate for 4 seconds, and then should stop.

CAUTION

Do not drive the fuel pump 4 seconds or more without the fuel in the fuel tank. If the fuel pump is driven without the fuel, it may be damaged.

- Measure the discharge for 4 seconds.
- Repeat this operation several times.

Amount of Fuel Flow

Standard: 72 mL (2.43 US oz.) or more for 4 seconds

- ★ If the fuel flow is much less than the specified, check the following:

Battery Condition (see Charging Condition Inspection in the Electrical System chapter)

- After inspection, connect the fuel hose (see Fuel Tank Installation).
- Start the engine and check for fuel leakage.

Fuel Pump

Fuel Pump Removal

CAUTION

Never drop the fuel pump, especially on a hard surface. Such a shock to the pump can damage it.

⚠ WARNING

Gasoline is extremely flammable and can be explosive under certain conditions. Make sure the area is well-ventilated and free from any source of flame or sparks; this includes any appliance with a pilot light. Do not smoke. Turn the ignition switch OFF. Disconnect the battery (-) terminal.

To make fuel spillage minimum, draw the fuel out from the fuel tank when the engine is cold. Be prepared for fuel spillage; any spilled fuel must be completely wiped up immediately.

- Draw the fuel out from the fuel tank with a commercially available electric pump.
- Remove the fuel tank (see Fuel Tank Removal).
- Be careful of fuel spillage from the fuel tank since fuel still remains in the fuel tank and fuel pump. Plug the fuel pipe of the fuel tank.
- Turn the fuel tank upside down.
- Unscrew the fuel pump bolts [A], and take out the fuel pump assembly [B] and gasket.
- Discard the fuel pump gasket.

CAUTION

Do not pull the leads [C] of the fuel pump and fuel reserve switch. If they are pulled, the lead terminals may be damaged.

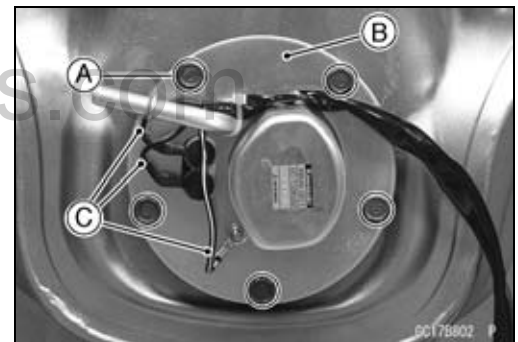

Fuel Pump Installation

- Remove dirt or dust from the fuel pump [A] by lightly applying compressed air.
- Replace the fuel pump gasket with a new one.

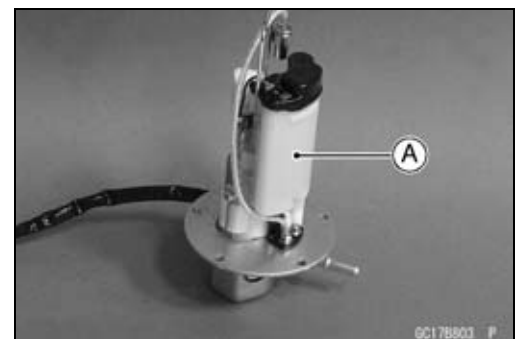

Fuel Pump

- Check that the fuel pump terminals [A], fuel reserve switch terminal [B] and band [C] are in place.
Front [D]
- Apply a non-permanent locking agent to the threads of the fuel pump bolts.
- Tighten the fuel pump bolts to a snug fit following the tightening sequence shown.
- Following the tightening sequence, tighten the pump bolts to the specified torque.

Torque - Fuel Pump Bolts: 10 N·m (1.0 kgf·m, 89 in·lb)

- Tighten the pump bolts again to check the tightness in the order shown.

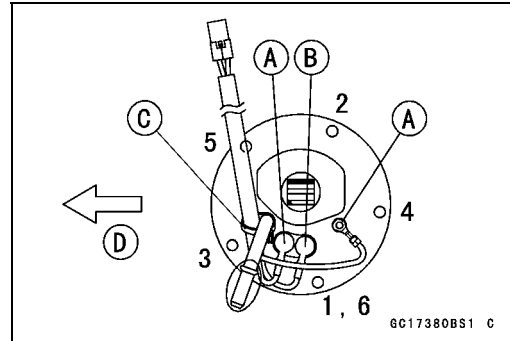

Operation Inspection

NOTE

○Be sure the battery is fully charged.

- Turn the ignition switch ON and make sure that the fuel pump operates (make light sounds) for 4 seconds, and then stops.
- Turn the ignition switch OFF.
- ★If the pump does not work as described above, inspect the operating voltage.

Operating Voltage Inspection

NOTE

○Be sure the battery is fully charged.

- Turn the ignition switch OFF.
- Remove the left side cover (see Side Cover Removal in the Frame chapter).
- Connect the hand tester (× 25 V DC) to the connector [A], with needle adapter set.

Special Tools - Hand Tester: 57001-1394

Needle Adapter Set: 57001-1457

Pump Operating Voltage at Pump Connections to Pump Connectors

Tester (+) → BK/Y Lead

Tester (-) → BK/W Lead

- Measure the operating voltage with the engine stopped, and with the connector joined.
- Turn the ignition switch ON.
- The tester needle should indicate battery voltage for 4 seconds, and then 0 V.

Operating Voltage at Pump Connector

Standard: Battery Voltage for 4 seconds, and then 0 V

- ★If the reading stays on battery voltage, and never shows 0 V. Check the ECU and fuel pump relay.
- ★If the voltage is in specification, but the pump doesn't work, replace the pump.
- ★If there is still no battery voltage, check the pump relay (see Fuel Pump Relay Inspection).



Fuel Pump

Fuel Pump Circuit

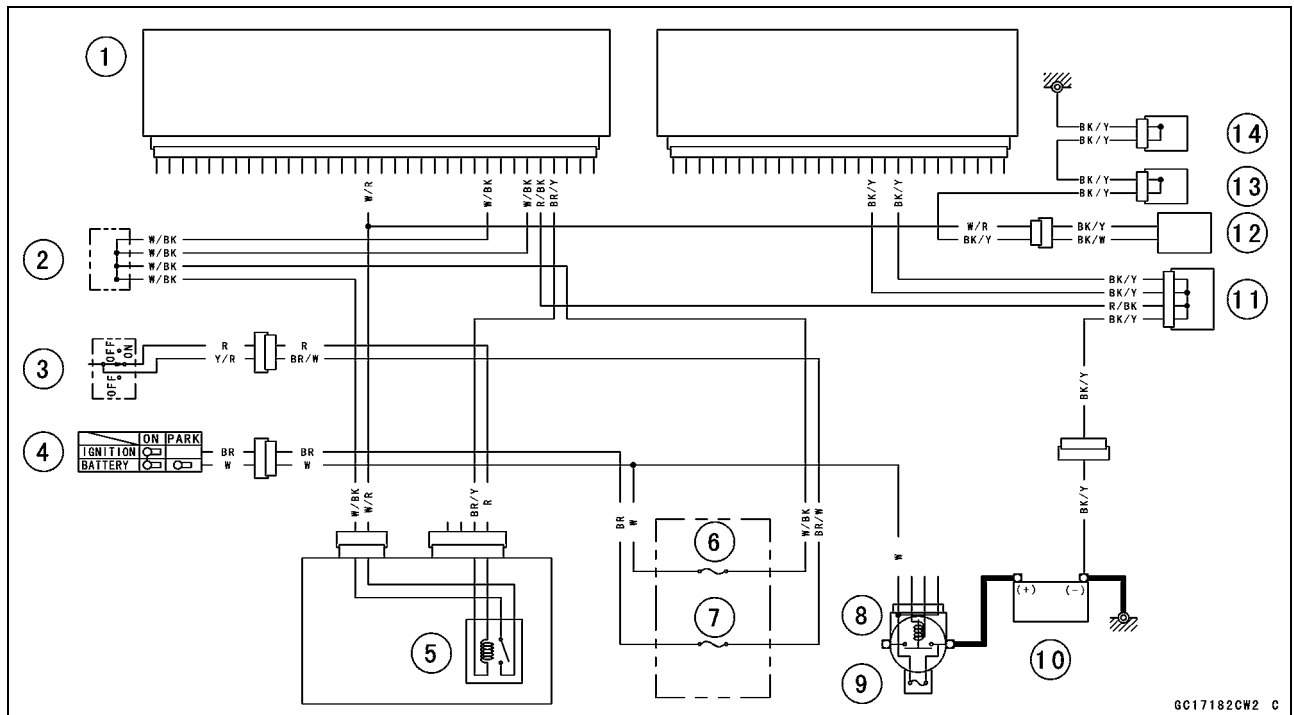

GC17182CW2 C

- 1. ECU
- 2. Water-proof Joint 1
- 3. Engine Stop Switch
- 4. Ignition Switch
- 5. Fuel Pump Relay
- 6. ECU Fuse 15 A
- 7. Ignition Fuse 15 A
- 8. Starter Relay
- 9. Main Fuse 30 A
- 10. Battery 12 V 10 Ah
- 11. Joint Connector 3
- 12. Fuel Pump
- 13. Joint Connector 2
- 14. Joint Connector 1

Fuel Injectors

Removal/Installation

- Refer to the Throttle Body Assy Disassembly/Assembly (see Throttle Body Assy Disassembly/Assembly).

CAUTION

<p>Never drop the injector, especially on a hard surface. Such a shock to the injector can damage it.</p>
--

Power Source Voltage Inspection

NOTE

○Be sure the battery is fully charged.

- Turn the ignition switch OFF.
- Remove the ECU (see ECU Removal).
- Do not disconnect the ECU connectors.
- Connect a digital meter [A] to the connector [B], with the needle adapter set.

Special Tool - Needle Adapter Set: 57001-1457

Injector Power Source Voltage at ECU Connector

Connections to ECU Connector

Meter (+) → W/R lead (terminal 14)

Meter (-) → Battery (-) Terminal

- Measure the power source voltage with the engine stopped, and with the connectors joined.
- Turn the ignition switch ON.

Power Source Voltage at ECU

Standard: Battery Voltage for 4 seconds, and then 0 V

- ★ If the power source voltage is less than the standard, check the fuel pump relay (see Fuel Pump Relay Inspection), wiring (see wiring diagram in this section), and the ECU for its ground, and power supply (see ECU Power Supply Inspection chapter). If the relay, wiring, ground and power supply are good, replace the ECU (see ECU section).

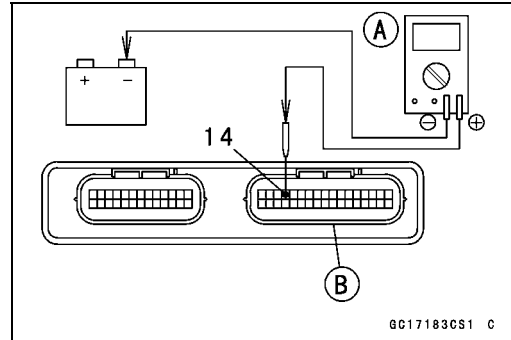

GC17183CS1 C

Fuel Injectors

- ★ If the reading is normal, remove the fuel tank (see Fuel Tank Removal), and check the power source voltage at the injector connector [B], with a digital meter [A].
- Measure the power source voltage with the engine stopped, and the connector joined, with a digital meter and needle adapter set [C].

Special Tool - Needle Adapter Set: 57001-1457

Injector Power Source Voltage at Injector Connections to Injector #1, #2, #3, #4

Meter (+) → W/R lead [E]

Meter (-) → Battery (-) Terminal [D]

- Turn the ignition switch ON.

Power Source Voltage at Injector Connector

Standard: Battery Voltage for 4 seconds, and then 0 V

- Turn the ignition switch OFF.
- ★ If the reading is out of the standard, check the wiring (see wiring diagram in this section).
- ★ If the reading is good, and the power source voltage is normal, check the output voltage.

Output Voltage Inspection

- Measure the output voltage at the ECU connector in the same way as power source voltage inspection. Note the following.

Digital Meter [A]

Connector [B]

Special Tool - Needle Adapter Set: 57001-1457

Injector Output Voltage at ECU

Connections for Injector #1

Meter (+) → BL/R lead (terminal 46)

Meter (-) → Battery (-) Terminal

Connections for Injector #2

Meter (+) → BL/G lead (terminal 59)

Meter (-) → Battery (-) Terminal

Connections for Injector #3

Meter (+) → BL/BK lead (terminal 44)

Meter (-) → Battery (-) Terminal

Connections for Injector #4

Meter (+) → BL/Y lead (terminal 57)

Meter (-) → Battery (-) Terminal

- Turn the ignition switch ON.

Output Voltage at ECU

Standard: Battery Voltage for 4 seconds, and then 0 V

- ★ If the output voltage is normal, check the ECU for its ground, and power supply (see ECU Power Supply Inspection).
- ★ If the ground and power supply are good, replace the ECU (see ECU section).

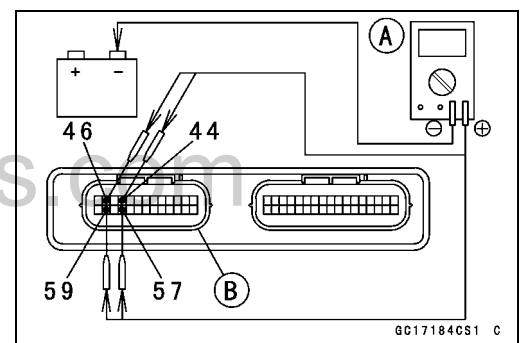
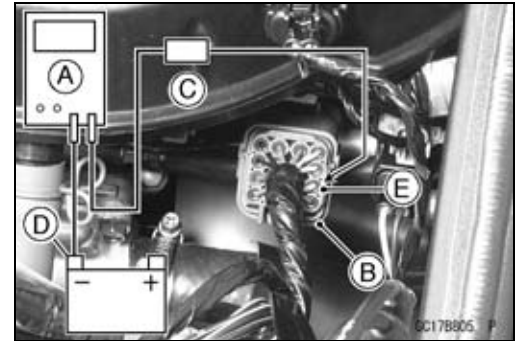

Fuel Injectors

★ If the output voltage is out of the standard, remove the air cleaner housing, and check the output voltage at the injector connector [B] using a digital meter [A] and needle adapter set [C] (when the lead is open, the output voltage is 0 V).

Special Tool - Needle Adapter Set: 57001-1457

Injector Output Voltage at Injector Connections to Injector #1

- Meter (+) → BL/R lead [E]
- Meter (-) → Battery (-) Terminal [D]

Connections to Injector #2

- Meter (+) → BL/G lead [F]
- Meter (-) → Battery (-) Terminal [D]

Connections to Injector #3

- Meter (+) → BL/BK lead [G]
- Meter (-) → Battery (-) Terminal [D]

Connections to Injector #4

- Meter (+) → BL/Y lead [H]
- Meter (-) → Battery (-) Terminal [D]

● Turn the ignition switch ON.

Output Voltage at Injector Connector

Standard: Battery Voltage for 4 seconds, and then 0 V

- ★ If the output voltage is normal, check the wiring for continuity (see wiring diagram in this section).
- ★ If the wiring is good, perform “Audible Inspection” for confirmation.
- ★ If the output voltage is out of the standard, perform “Audible Inspection” for confirmation.

Audible Inspection

- Remove:
 - Fuel Tank (see Fuel Tank Removal)
 - Air Cleaner Housing (see Air Cleaner Housing Removal)
- Connect the following parts temporary.
 - Fuel Pump Lead Connector [A]
 - Extension Tube [B]

Special Tool - Extension Tube: 57001-1578

- Start the engine.
- Apply the tip of a screwdriver [A] to the injector [B]. Put the grip end onto your ear, and listen whether the injector is clicking or not.
- A sound scope can also be used.
- Do the same for the other injector.
- ★ If all the injectors click at a regular intervals, the injectors are good.
- The click interval becomes shorter as the engine speed rises.
- ★ If either injector doesn't click, perform the “Injector Signal Test” for injector operation.

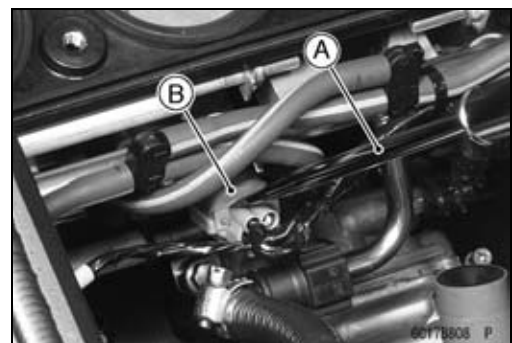
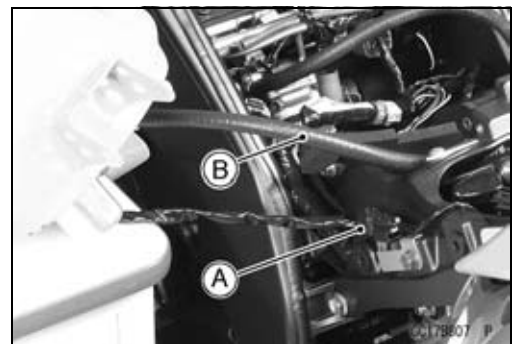
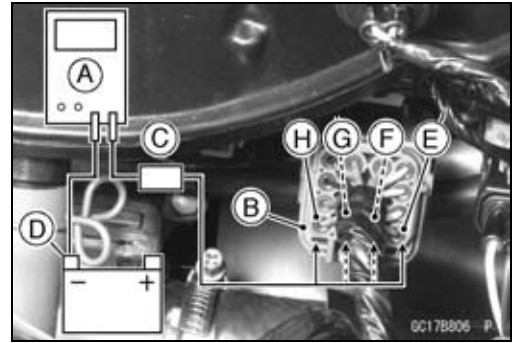

Fuel Injectors

Injector Signal Test

- Prepare two test light sets with male terminals as shown.
Rating of Bulb [A]: 12 V × 3 ~ 3.4 W
Terminal Width [B]: 1.8 mm (0.07 in.)
Terminal Thickness [C]: 0.8 mm (0.03 in.)

CAUTION

Do not use larger terminals than specified above. A larger terminal could damage the injector main harness connector (female), leading to harness repair or replacement.

Be sure to connect bulbs in series. The bulb works as a current limiter to protect the solenoid in the injector from excessive current.

- Disconnect the connectors for injector [A].
- Connect each test light set [B] to the injector sub harness connector [C].
- Turn the ignition switch ON.
- While cranking the engine with the starter motor, watch the test lights.
- ★ If the test lights flicker at regular intervals, the injector circuit in the ECU, and the wiring are good. Perform the "Injector Resistance Inspection".

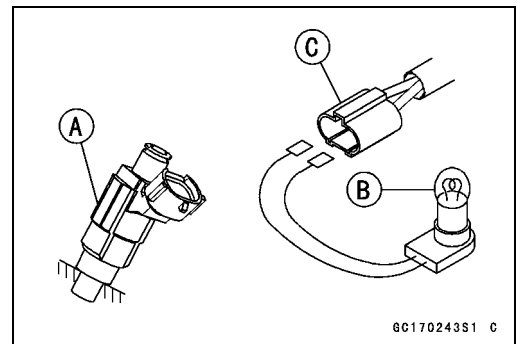
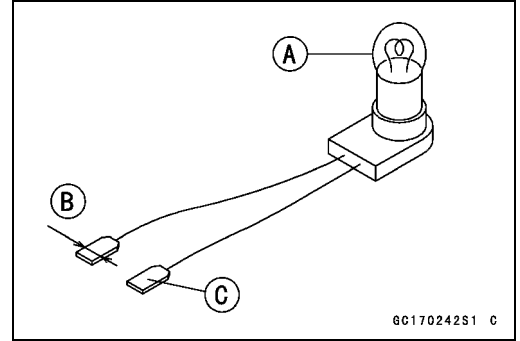

○ Injector signals can be also confirmed by connecting the hand tester (× 10 V AC) instead of the test light set to the injector main harness (female) connector. Crank the engine with the starter motor, and check to see if the hand oscillates at regular intervals.

Special Tool - Hand Tester: 57001-1394

- ★ If the test light doesn't flicker (or the test hand doesn't oscillates), check the wiring and connectors again. If the wiring is good, replace the ECU (see ECU section).

Injector Resistance Inspection

- Remove the air cleaner housing (see Air Cleaner Housing Removal).
- Disconnect the connector from the injector [A] (see Throttle Body Disassembly/Assembly).
- Measure the injector resistance with a digital meter.

Injector Resistance

Connections to Injector

Meter (+)		Meter (-)
#1: W/R	↔	BL/R Terminal
#2: W/R	↔	BL/G Terminal
#3: W/R	↔	BL/BK Terminal
#4: W/R	↔	BL/Y Terminal

Standard: about 11.7 ~ 12.3 Ω at 20°C (68°F)

- ★ If the reading is out of the range, perform the "Injector Unit Test".

- ★ If the reading is normal, perform the "Injector Unit Test"

for confirmation
www.zxforums.com



Fuel Injectors

Injector Unit Test

- Use two leads [A] and the same test light set [B] as in "Injector Signal Test".
- Rating of Bulb [C]: 12 V × (3 ~ 3.4) W
- 12 V MF Battery [D]

CAUTION

Be sure to connect the bulb in series. The bulb works as a current limiter to protect the solenoid in the injector from excessive current.

- Connect the test light set to the injector [E] as shown.
- Open and connect [F] the end of the lead to the battery (-) terminal repeatedly. The injector should click.
- ★ If the injector does not click, replace the injector.

Injector Fuel Line Inspection

- Remove the throttle body assy (see Throttle Body Assy Removal).
- Check the injector fuel line for leakage as follows.
 - Connect a commercially available vacuum/pressure pump [A] to the nipple of the delivery pipe [B] with the fuel hose [C] (both ends connected with the clamps [D]) as shown.
 - Apply soap and water solution to the areas [E] as shown.
 - Watching the pressure gauge, squeeze the pump lever [F], and build up the pressure until the pressure reaches the maximum pressure.

Fuel Line Maximum Pressure

Standard: 300 kPa (3.06 kgf/cm², 43 psi)

CAUTION

During pressure testing, do not exceed the maximum pressure for which the system is designed.

- Watch the gauge for at least 6 seconds.
- ★ If the pressure holds steady, the system is good.
- ★ If the pressure drops at once, or if bubbles are found in the area, the line is leaking. Replace the delivery pipe, injectors and related parts.
- Repeat the leak test, and check the fuel line for no leakage.
- Install the throttle body assy (see Throttle Body Assy Installation).
- Run the hoses correctly (see Cable, Wire, and Hose Routing section in the Appendix chapter).

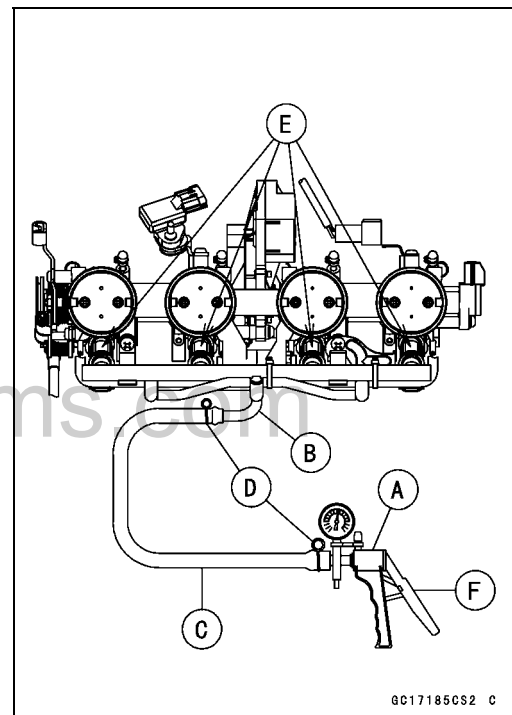
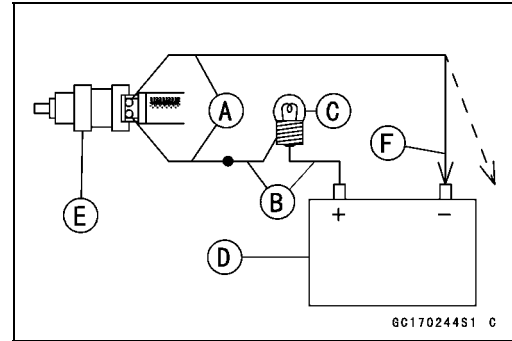

Fuel Injectors

Fuel Injector Circuit

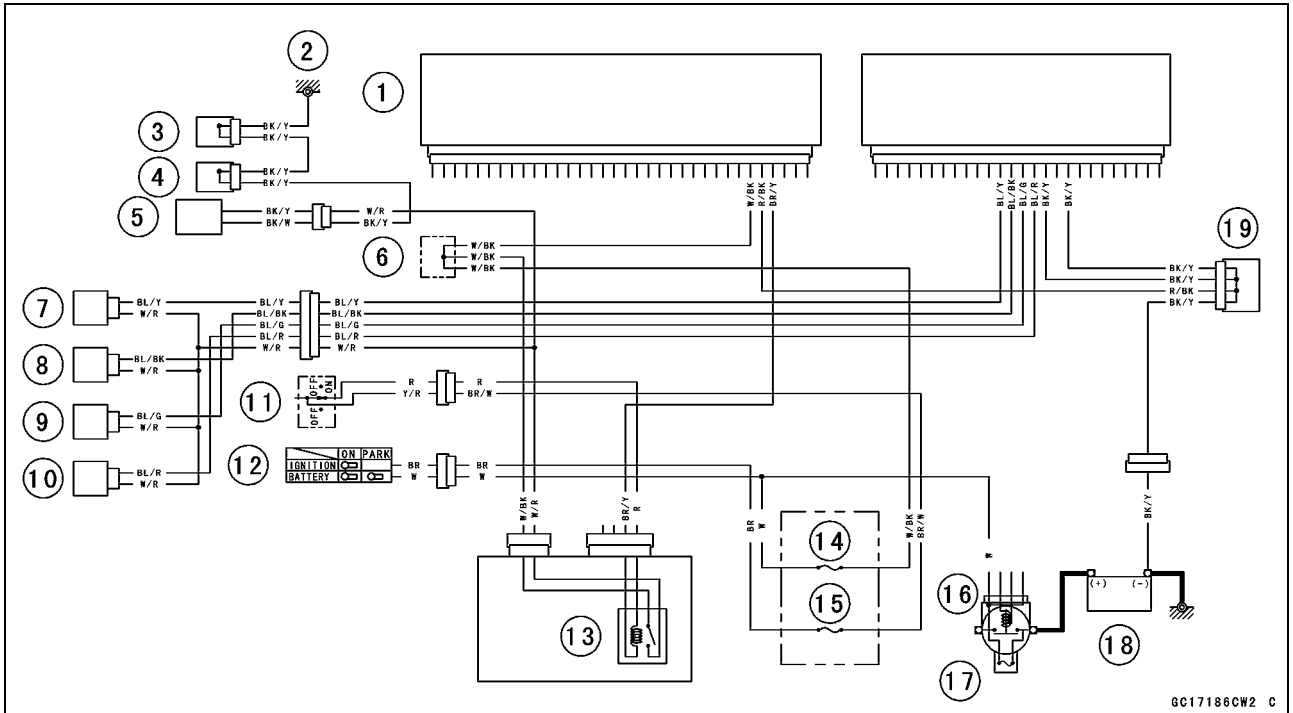

- 1. ECU
- 2. Frame Ground
- 3. Joint Connector 1
- 4. Joint Connector 2
- 5. Fuel Pump
- 6. Water-proof Joint 1
- 7. Fuel Injector #4
- 8. Fuel Injector #3
- 9. Fuel Injector #2
- 10. Fuel Injector #1
- 11. Engine Stop Switch
- 12. Ignition Switch
- 13. Fuel Pump Relay
- 14. ECU Fuse 15 A
- 15. Ignition Fuse 15 A
- 16. Starter Relay
- 17. Main Fuse 30 A
- 18. Battery 12 V 10 Ah
- 19. Joint Connector 3

Throttle Grip and Cables

Free Play Inspection

- Refer to the Throttle Control System Inspection in the Periodic Maintenance chapter (see Throttle Control System Inspection in the Periodic Maintenance chapter).

Free Play Adjustment

- Refer to the Throttle Control System Inspection in the Periodic Maintenance chapter (see Throttle Control System Inspection in the Periodic Maintenance chapter).

Cable Installation

- Install the throttle cables in accordance with the Cable Routing section in the Appendix chapter.
- Install the lower ends of the throttle cables in the cable bracket on the throttle assy after installing the upper ends of the throttle cables in the grip.
- After installation, adjust each cable properly (see Throttle Control System Inspection in the Periodic Maintenance chapter).

⚠ WARNING

Operation with incorrectly routed or improperly adjusted cables could result in an unsafe riding condition.

Cable Lubrication

- Refer to the Chassis Parts Lubrication Perform in the Periodic Maintenance chapter (see Chassis Parts Lubrication Perform in the Periodic Maintenance chapter).

Throttle Body Assy

Idle Speed Inspection

- Refer to the Idle Speed Inspection in the Periodic Maintenance chapter (see Idle Speed Inspection in the Periodic Maintenance chapter).

Throttle Bore Cleaning

- Check the throttle bore for cleanliness as follows.
 - Remove the throttle body assy (see Throttle Body Assy Removal).
 - Check the main throttle valves and throttle bores [A] for carbon deposits by opening the main throttle valves.
 - ★ If any carbon accumulates, wipe the carbon off the throttle bores around the throttle bores and the throttle valves, using a cotton pad penetrated with a high-flash point solvent.

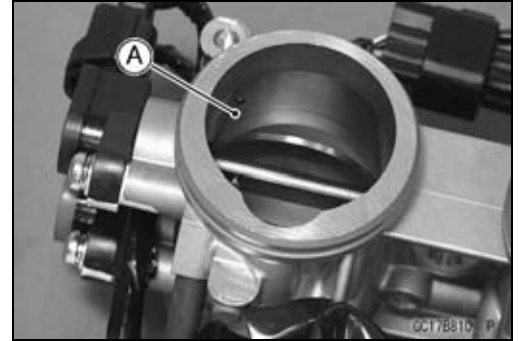

Synchronization Inspection

- Refer to the Engine Vacuum Synchronization Inspection in the Periodic Maintenance chapter (see Engine Vacuum Synchronization Inspection in the Periodic Maintenance chapter).

Synchronization Adjustment

- Refer to the Engine Vacuum Synchronization Inspection in the Periodic Maintenance chapter (see Engine Vacuum Synchronization Inspection in the Periodic Maintenance chapter).

Throttle Body Assy Removal

⚠ WARNING

Gasoline is extremely flammable and can be explosive under certain conditions. Turn the ignition switch OFF. Disconnect the battery (-) cable terminal. Do not smoke. Make sure the area is well-ventilated and free from any source of flame or sparks; this includes any appliance with a pilot light.

Be prepared for fuel spillage: any spilled fuel must be completely wiped up immediately.

- Remove:
 - Fuel Tank (see Fuel Tank Removal)
 - Air Cleaner Housing (see Air Cleaner Housing Removal)
- Be sure to place a piece of cloth around the delivery pipe [A] of the throttle body assy.
- Disconnect the connectors [B].

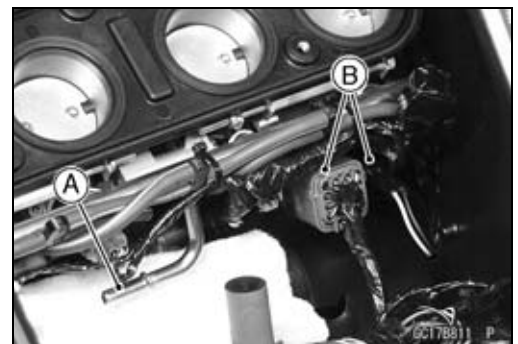

Throttle Body Assy

- Remove:
Air Switching Valve Hose [A]
Vacuum Hoses [B] (California Model)

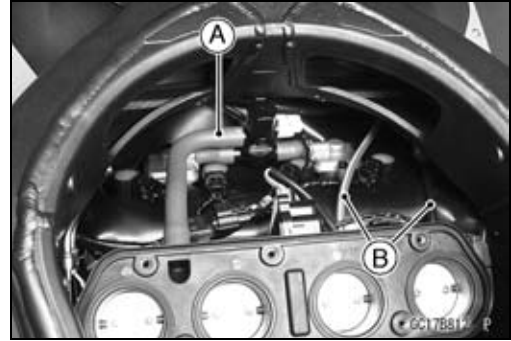

- Remove the middle fairings (see Middle Fairing Removal in the Frame chapter).
- Loosen the throttle body assy holder clamp bolts [A] on both sides.

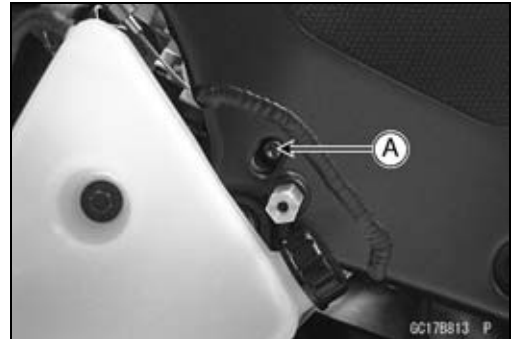

- Remove the throttle case [A] to make a throttle cable slack.

www.zxforums.com



- Remove the adjuster screw [A] from the clamp [B].

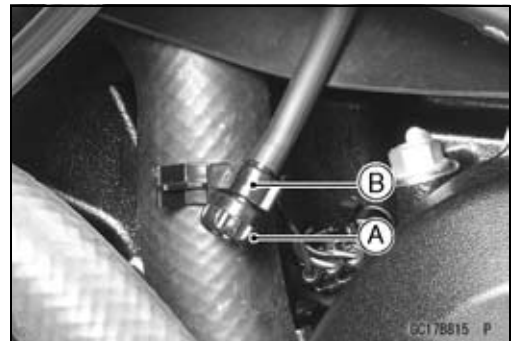

- Pull off the throttle body assy [A] from the holder.
- Remove:
Clamp [B]
Throttle Cable Lower Ends [C]

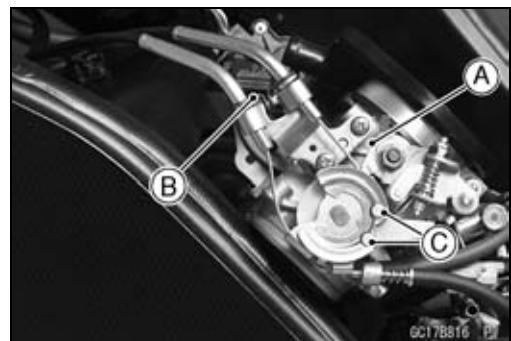

Throttle Body Assy

- After removing the throttle body assy, stuff pieces of lint-free, clean cloths into the throttle body assy holders.

CAUTION

If dirt gets into the engine, excessive engine wear and possible engine damage will occur.

- ★ If the throttle body assy is to be disassembly, loosen the air cleaner housing holder clamp bolts [A], and remove the air cleaner housing holder [B].

Throttle Body Assy Installation

- ★ If the air cleaner housing holder [A] was removed, install it.

- Install the holder clamp bolts [B] in the direction as shown. Bolt Heads [C]

Torque - Air Cleaner Housing Holder Clamp Bolts: 2.0 N·m (0.20 kgf·m, 18 in·lb)

- Install the holder clamp bolts [A] in the direction as shown. Bolt Heads [B]

- Tighten:

Torque - Throttle Body Assy Holder Clamp Bolts: 2.0 N·m (0.20 kgf·m, 18 in·lb)

- Run the leads and hoses as shown in the Cable, Wire, and Hose Routing section of the Appendix chapter.
- When installing the fuel hose, refer to Fuel Tank Installation.

- Adjust:

Throttle Grip Free Play (see Throttle Control System Inspection in the Periodic Maintenance chapter)

Idle Speed (see Idle Speed Adjustment in the Periodic Maintenance chapter)

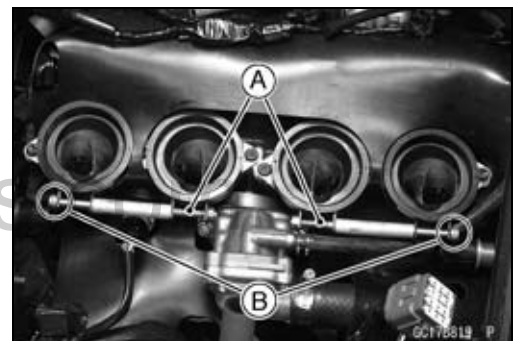
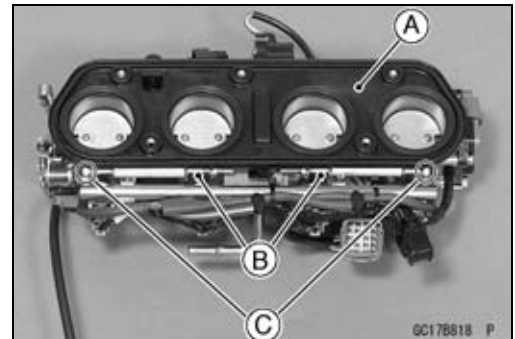
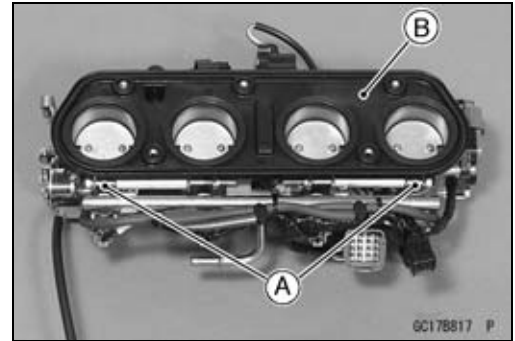

Throttle Body Assy

Throttle Body Assy Disassembly

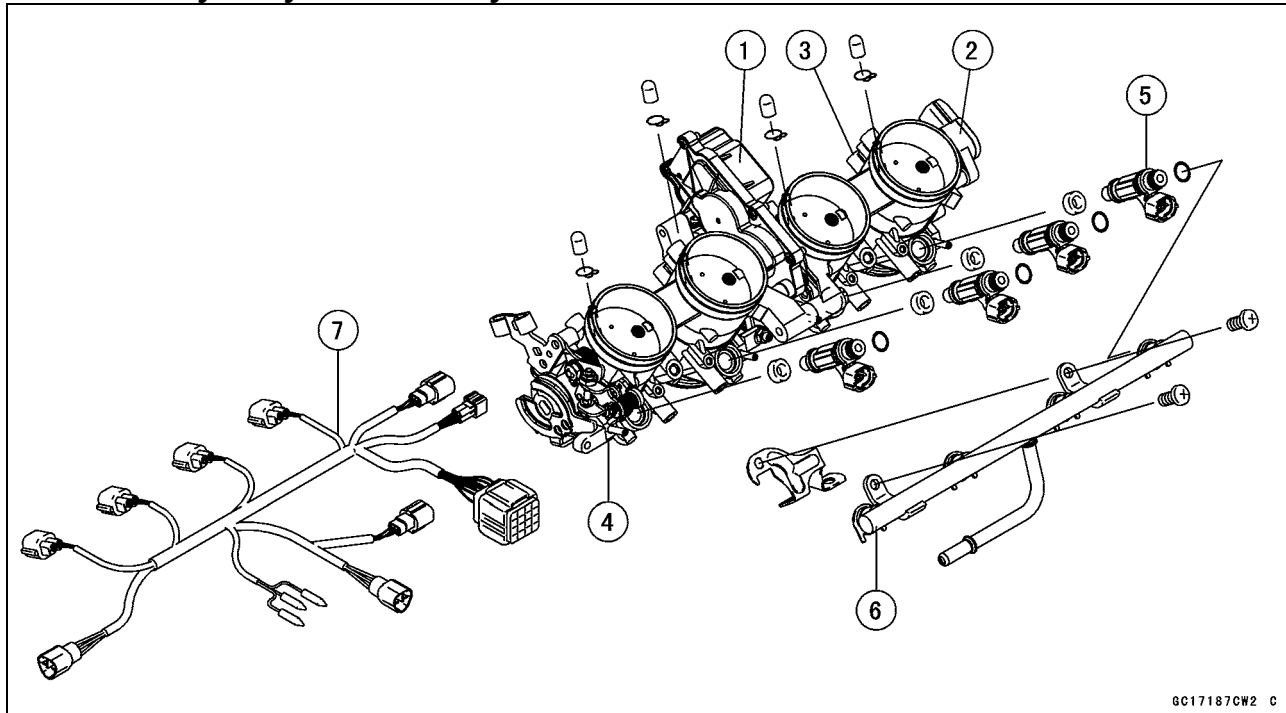

6C17187CW2 C

1. Subthrottle Valve Actuator
2. Subthrottle Sensor
3. Main Throttle Sensor
4. Throttle Body Assy
5. Injector
6. Delivery Pipe
7. Injector Connector Harness

www.zxforums.com

CAUTION

Do not remove, disassemble or adjust the main throttle sensor, subthrottle sensor, subthrottle valve actuator, throttle link mechanism and throttle body assy, because they are adjust or set surely at the manufacturer. Adjustment of these parts could result in poor performance, requiring replacement of the throttle body assy.

- Remove the throttle body assy (see Throttle Body Assy Removal).
- Disconnect the injector connectors [A].

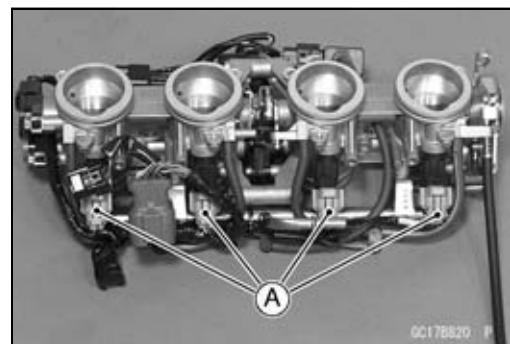

6C178B20 P

Throttle Body Assy

- Disconnect the main throttle sensor [A] and subthrottle sensor [B] connector.

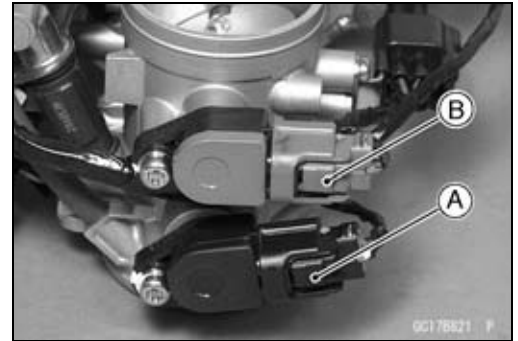

- Disconnect:
Subthrottle Valve Actuator Lead Connector [A]
Inlet Air Pressure Sensor Connector [B]

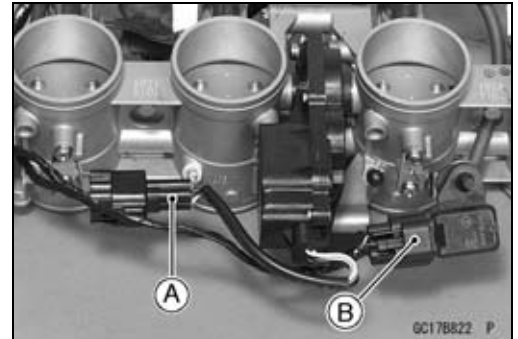

- Separate the hoses [A] from the throttle body fittings and inlet air pressure sensor.
- Remove the screws [B] to pull out the injector assies from the throttle body assy together with the delivery pipe [C].

NOTE

- Do not damage the insertion portions of the injectors when they are pulled out from the throttle body.

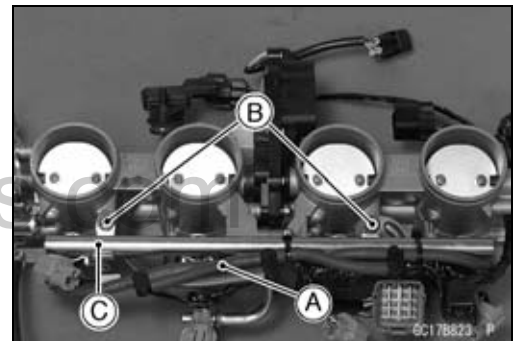

- Pull out the injectors [A] from the delivery pipe [B].

NOTE

- Do not damage the insertion portions of the injectors when they are pulled out from the delivery pipe.

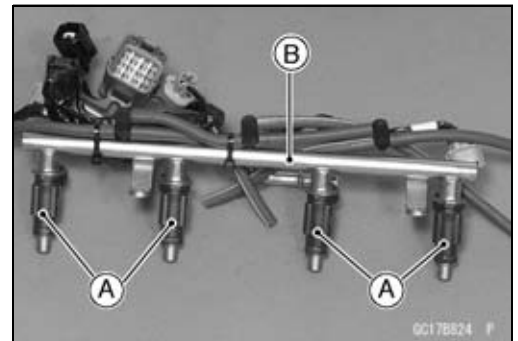

Throttle Body Assy Assembly

- Before assembling, blow away dirt or dust from the throttle body and delivery pipe by applying compressed air.
- Apply daphne oil or engine oil to the new O-rings [A] of each injector, insert them to the delivery pipe [B] and confirm whether the injectors turn smoothly or not.

NOTE

- Replace the O-rings of injectors to new ones.

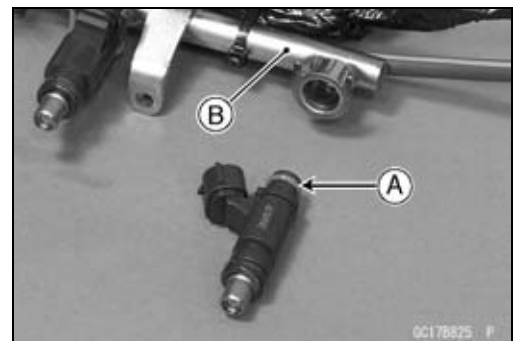

Throttle Body Assy

- Apply daphne oil or engine oil to the new dust seals [A], and insert the injectors into the throttle body, which installed to the delivery pipe.

NOTE

○Replace the dust seals of the throttle body to new ones.

- Install the delivery pipe to the throttle body.
Torque - Delivery Pipe Mounting Screws: 5.0 N·m (0.50 kgf·m, 44 in·lb)
- Connect the injector connectors.
- Insert the each hoses to the throttle body fittings and inlet air pressure sensor.
- Install the throttle body assy (see Throttle Body Assy Installation).

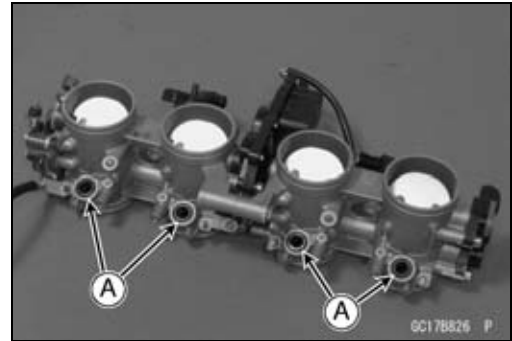

Air Line

Element Removal

- Refer to the Air Cleaner Element Replacement in the Periodic Maintenance chapter (see Air Cleaner Element Replacement in the Periodic Maintenance chapter).

Element Installation

- Refer to the Air Cleaner Element Replacement in the Periodic Maintenance chapter (see Air Cleaner Element Replacement in the Periodic Maintenance chapter).

Air Cleaner Element Inspection

- Remove the air cleaner element (see Air Cleaner Element Replacement in the Periodic Maintenance chapter).
- Visually check the element [A] for tears or breaks.
- ★ If the element has any tears or breaks, replace the element.

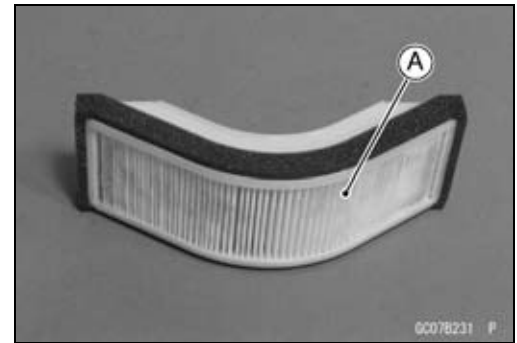

Air Cleaner Housing Removal

- Remove:
 - Air Cleaner Element (see Air Cleaner Element Replacement in the Periodic Maintenance chapter)
 - Air Cleaner Housing Mounting Bolts [A]
 - Inlet Air Temperature Sensor [B]
- Do not disconnect the inlet air temperature sensor lead connector.



- Remove the hoses [A].
- Remove the air cleaner housing [B] from the air ducts and holder.

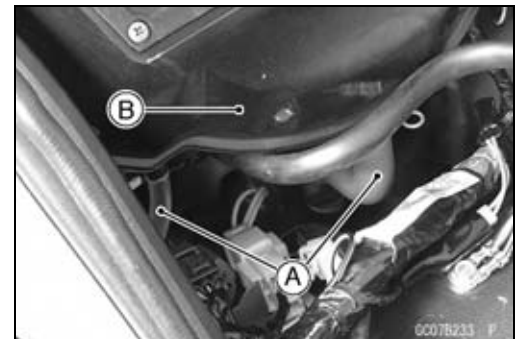

Air Line

- Turn the air cleaner housing [A] counterclockwise [B] and remove it.

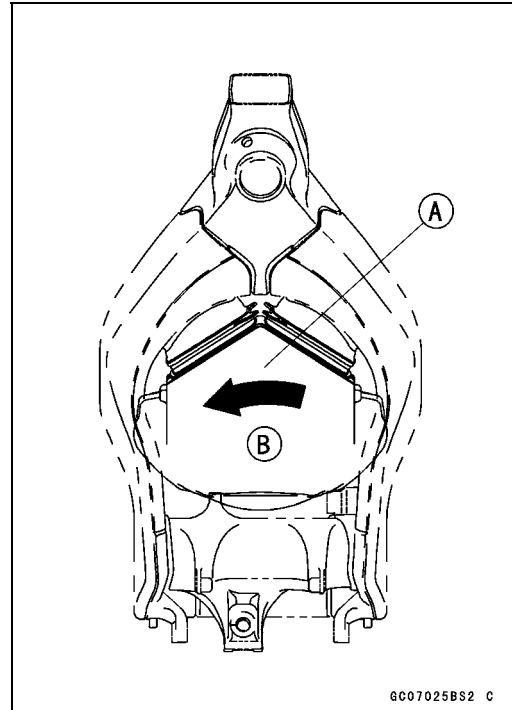

- Pull off the air ducts [A] from the frame.

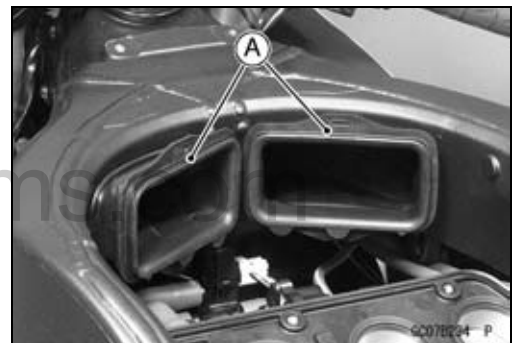

www.zxforums.com

Air Cleaner Housing Installation

- Confirm the air ducts [A] fit in the frame [B].
- Insert the air cleaner housing [C] inside the frame as shown.
- Turn the housing clockwise and position it.

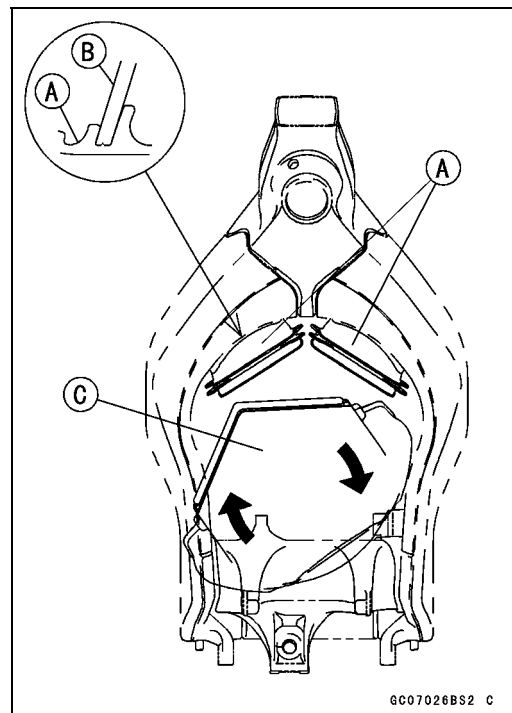

Air Line

- Install the housing on the holder then insert the ducts.
- Apply a soap and water solution [A] to the ducts for easy installation.
- Insert the projections [B] of the housing in the holes [C] of the ducts.
- Tighten:
 - Torque - Air Cleaner Housing Mounting Bolts: 7.0 N·m (0.70 kgf·m, 62 in·lb)**
- Install the air cleaner element (see Air Cleaner Element Replacement in the Periodic Maintenance chapter).

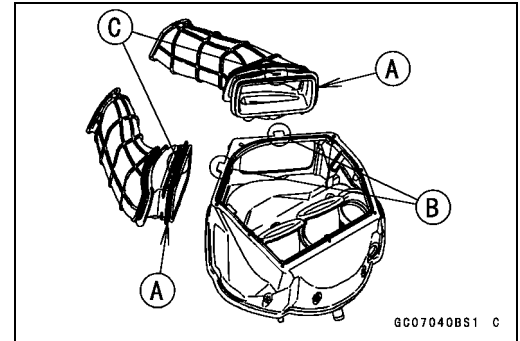

Air Cleaner Housing Disassembly

- Remove:
 - Air Cleaner Housing (see Air Cleaner Housing Removal)
 - Air Cleaner Housing Screws [A]
 - Lower Housing [B]
 - Duct Holder Screws [C]
 - Ducts and Duct Holders
 - Filter

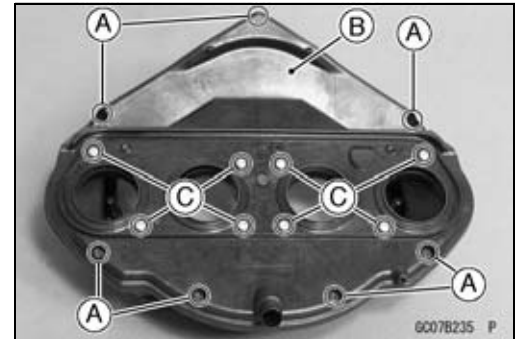

Air Cleaner Housing Assembly

- Install:
 - Ducts [A] and Duct Holders [B]
 - Filter [C]
- ★ If the filter is dirt, clean the filter in cleaning solvent, and then dry it with compressed air or squeeze it.

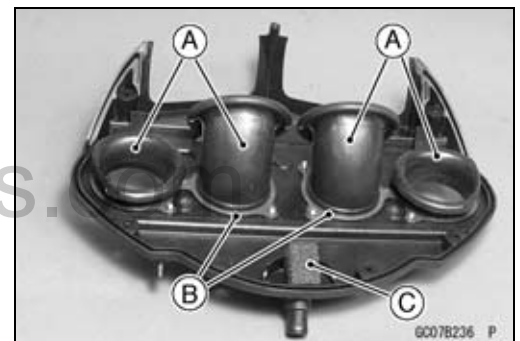

- Insert the seal [A] into the groove in the lower housing [B].
- Apply liquid gasket to the mesh patterns [C] on the lower housing.

Sealant - Kawasaki Bond (Liquid Gasket - Black): 92104-0002

- Wipe off any protruding liquid gasket.
- Fit the upper and lower housings, and tighten the screws securely.

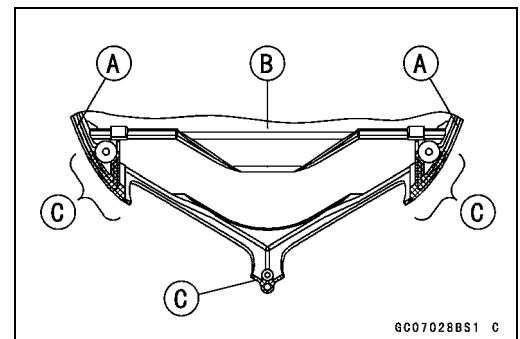

Oil Draining

A drain hose is connected to the bottom of the air cleaner part to drain water or oil accumulated in the cleaner part.

- Remove the left lower fairing (see Lower Fairing Removal in the Frame chapter).
- Visually check the drain hose end [A], if the water or oil accumulates in the hose.
- ★ If any water or oil accumulates in the hose, remove the plug [B] from the drain hose and drain it.

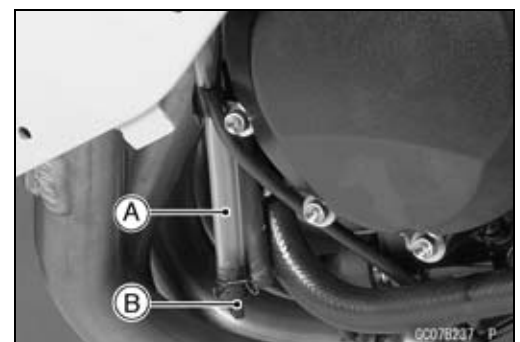

⚠ WARNING

Be sure reinstall the plug in the drain hose after draining. Oil on tires will make them slippery and can cause an accident and injury.

Air Line

Air Inlet Duct Removal

- Remove:
 - Upper Fairing (see Upper Fairing Removal in the Frame chapter)
 - Mounting Bolts [A] (Both Sides)
 - Air Inlet Duct [B]

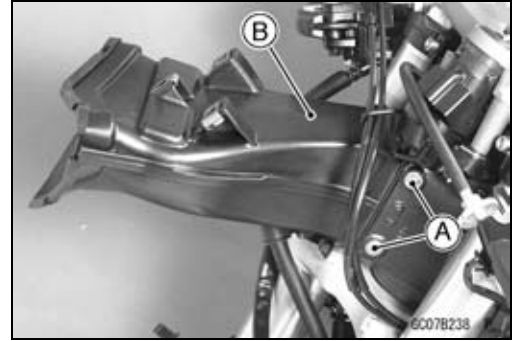

Air Inlet Duct Installation

- Install the gasket [A].
 - Apply non-permanent locking agent to the threads of the air inlet duct mounting bolts [B] and tighten it.
- Torque - Air Inlet Duct Mounting Bolts: 7.0 N·m (0.70 kgf·m, 62 in·lb)**

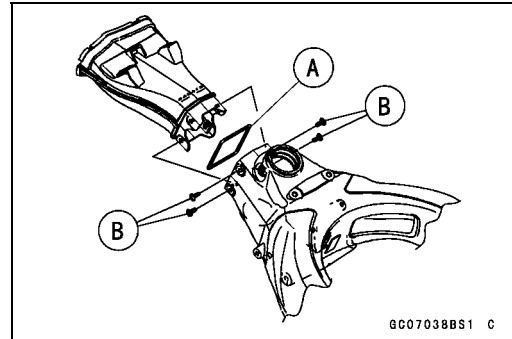

Fuel Tank

Fuel Tank Removal

⚠ WARNING

Gasoline is extremely flammable and can be explosive under certain conditions. Make sure the area is well-ventilated and free from any source of flame or sparks; this includes any appliance with a pilot light. Do not smoke. Turn the ignition switch OFF. Be prepared for fuel spillage; any spilled fuel must be completely wiped up immediately.

- Turn the ignition switch OFF.
- Remove the front seat (see Front Seat Removal in the Frame chapter).
- Disconnect the battery (–) terminal (see Battery Removal in the Electrical System chapter).
- Remove:
 - Steering Damper (see Steering Damper Removal in the Steering chapter)
 - Fuel Tank Bolts [A]
- Disconnect the fuel pump lead connector [A].

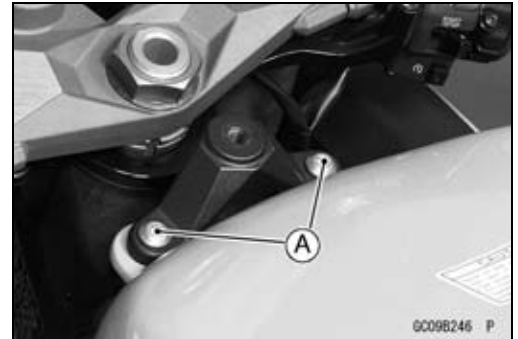

- For the California model, remove the following.
 - Fuel Return Hose [A] (front side, red)
 - Fuel Tank Breather Hose [B] (rear side, blue)

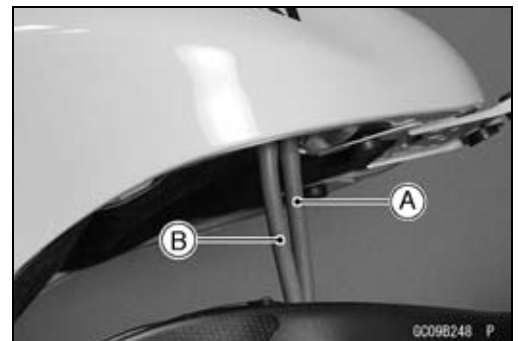

- Open the fuel tank cap [A] to lower the pressure in the tank.
- During tank removal, keep the tank cap open to release pressure in the tank. This makes fuel spillage less.

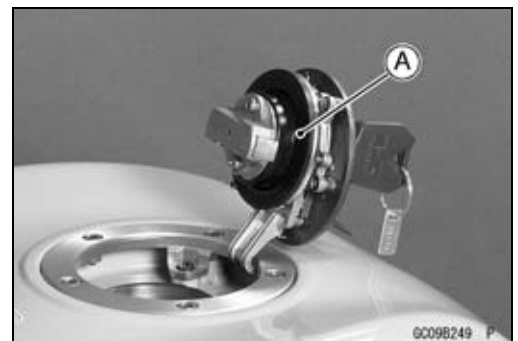

Fuel Tank

- Draw the fuel out from the fuel tank with a commercially available pump [A].
- Use a soft plastic hose [B] as a pump inlet hose in order to insert the hose smoothly.
- Put the hose through the fill opening [C] into the tank and draw the fuel out.

Front [D]

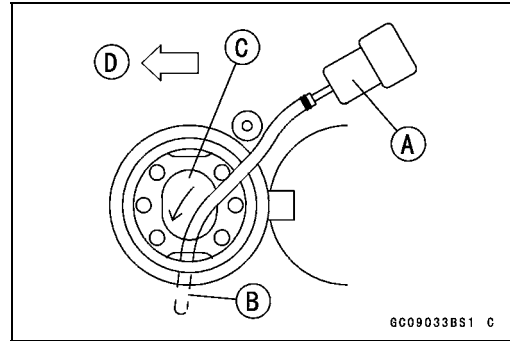

⚠ WARNING

The fuel could not be removed completely from the fuel tank. Be careful for remained fuel spillage.

- Be sure to place a piece of cloth [A] around the fuel hose joint.
- Insert a minus screw driver [B] into the slit [C] on the joint lock.



- Turn [A] the driver to disconnect the joint lock [B].
- Pull [C] the fuel hose joint out [D] of the outlet pipe.



www.zxforums.com

⚠ WARNING

Be prepared for fuel spillage; any spilled fuel must be completely wiped up immediately. When the fuel hose is disconnected, fuel spills out from the hose and the pipe because of residual pressure. Cover the hose connection with a piece of clean cloth to prevent fuel spillage.

- Remove:
 - Fuel Tank Bolt [A]
 - Drain Hose [B]
- Close the fuel tank cap.
- Remove the fuel tank [C], and place it on a flat surface.
- Do not apply the load to the outlet pipe of the fuel pump.

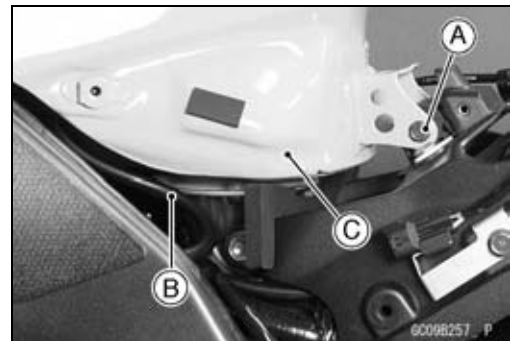

Fuel Tank

- For the California Model, note the following.

CAUTION

For the California model, if gasoline, solvent, water or any other liquid enters the canister, the canister's vapor absorbing capacity is greatly reduced. If the canister does become contaminated, replace it with a new one.

- Be sure to plug the evaporative fuel return hose to prevent fuel spilling before fuel tank removal.

⚠ WARNING

For the California model, be careful not to spill the gasoline through the return hose. Spilled fuel is hazardous.

- ★ If liquid or gasoline flows into the breather hose, remove the hose and blow it clean with compressed air (California model).
- Be careful of fuel spillage from the fuel tank since fuel still remains in the fuel tank and fuel pump.

⚠ WARNING

Store the fuel tank in an area which is well-ventilated and free from any source of flame or sparks. Do not smoke in this area. Place the fuel tank on a flat surface and plug the fuel pipes to prevent fuel leakage.

Fuel Tank Installation

- Note the above WARNING (see Fuel Tank Removal).
- Route the hoses correctly (see Cable, Wire, and Hose Routing section in the Appendix chapter).
- Check that the dampers [A] and pad [B] are in place on the fuel tank as well.
- ★ If the dampers are damaged or deteriorated, replace them.
- For the California Model, note the following.
 - To prevent the gasoline from flowing into or out of the canister, hold the separator perpendicular to the ground.
 - Connect the hoses according to the diagram of the system (see Cable, Wire, and Hose Routing section in the Appendix chapter). Make sure they do not get pinched or kinked.
 - Route hoses with a minimum of bending so that the air or vapor will not be obstructed.

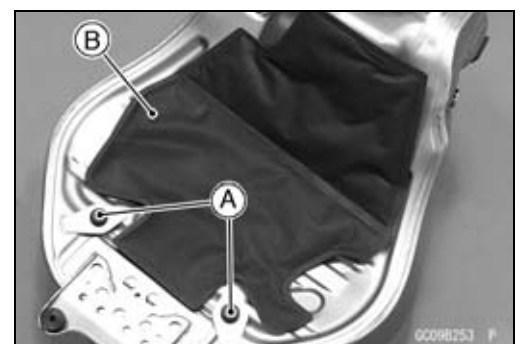
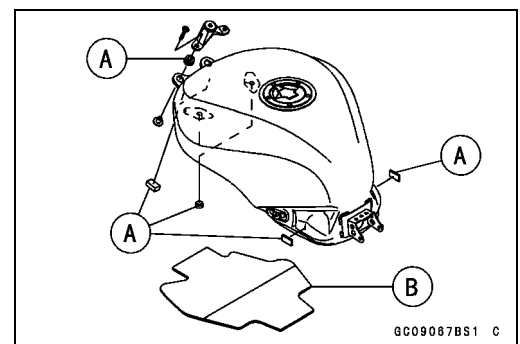

Fuel Tank

- Insert the fuel hose joint [A] straight onto the delivery pipe until the hose joint clicks.
- Push [B] the joint lock [C] until the hose joint clicks.



- Push and pull [A] the hose joint [B] back and forth more than two times and make sure it is locked and doesn't come off.

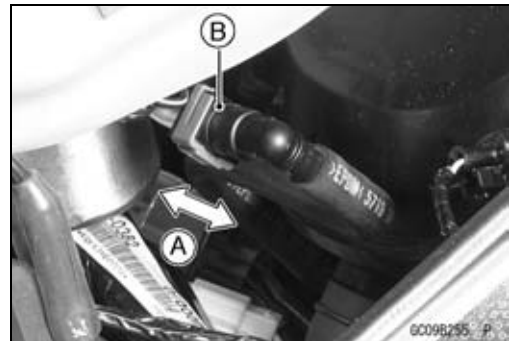

⚠ WARNING
Make sure the hose joint is installed correctly on the delivery pipe by sliding the joint, or the fuel could leak.

- ★ If it comes off, reinstall the hose joint.
- Connect the fuel pump lead connector and the battery (-) terminal (see Battery Installation in the Electrical System chapter).

Fuel Tank and Cap Inspection

- Visually inspect the gasket [A] on the tank cap for any damage.
- ★ Replace the gasket if it is damaged.
- Check to see if the water drain pipe [B] and fuel breather pipe [C] (California Model) in the tank are not clogged. Check the tank cap breather also.
- ★ If they are clogged, remove the tank and drain it, and then blow the breather free with compressed air.

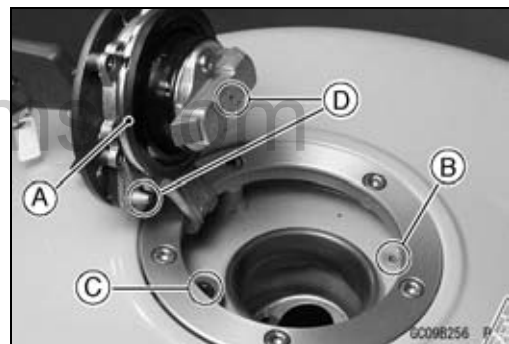

CAUTION
Do not apply compressed air to the air vent holes [D] in the tank cap. This could cause damage and clogging of the labyrinth in the cap.

Fuel Tank Cleaning

⚠ WARNING
Clean the tank in a well-ventilated area, and take care that there are no sparks or flame anywhere near the working area. Because of the danger or highly flammable liquids, do not use gasoline or low-flash point solvents to clean the tank.

- Remove:
 - Fuel Tank (see Fuel Tank Removal)
 - Fuel Pump (see Fuel Pump Removal)
- Pour some high-flash point solvent into the fuel tank and shake the tank to remove dirt and fuel deposits.
- Draw the solvent out of the fuel tank.
- Dry the tank with compressed air.
- Install:
 - Fuel Pump (see Fuel Pump Installation)
 - Fuel Tank (see Fuel Tank Installation)

Evaporative Emission Control System

The Evaporative Emission Control System routes fuel vapors from the fuel system into the running engine or stores the vapors in a canister when the engine is stopped. Although no adjustments are required, a thorough visual inspection must be made at the intervals specified by the Periodic Maintenance Chart.

Parts Removal/Installation

⚠ WARNING

Gasoline is extremely flammable and can be explosive under certain conditions. Turn the ignition switch OFF. Do not smoke. Make sure the area is well-ventilated and free from any source of flame or sparks; this includes any appliance with a pilot light.

CAUTION

If gasoline, solvent, water or any other liquid enters the canister, the canister's vapor absorbing capacity is greatly reduced. If the canister does become contaminated, replace it with a new one.

- To prevent the gasoline from flowing into or out of the canister, hold the separator perpendicular to the ground.
- Connect the hoses according to the diagram of the system. Make sure they do not get pinched or kinked.

Hose Inspection

- Refer to the Evaporative Emission Control System Inspection in the Periodic Maintenance chapter (see Evaporative Emission Control System Inspection in the Periodic Maintenance chapter).

Separator Inspection

- Refer to the Evaporative Emission Control System Inspection in the Periodic Maintenance chapter (see Evaporative Emission Control System Inspection in the Periodic Maintenance chapter).
Separator [A]



Evaporative Emission Control System

Separator Operation Test

⚠ WARNING

Gasoline is extremely flammable and can be explosive under certain conditions. Turn the ignition switch OFF. Do not smoke. Make sure the area is well-ventilated and free from any source of flame or sparks; this includes any appliance with a pilot light.

- Connect the hoses to the separator, and install the separator on the motorcycle.
- Disconnect the breather hose from the separator, and inject about 20 mL (0.68 US oz.) of gasoline [A] into the separator [B] through the hose fitting.
- Disconnect the fuel return hose [C] from the fuel tank [D].
- Run the open end of the return hose into the container and hold it level with the tank top [E].
- Start the engine, and let it idle.
- ★ If the gasoline in the separator comes out of the hose, the separator works well. If it does not, replace the separator with a new one.

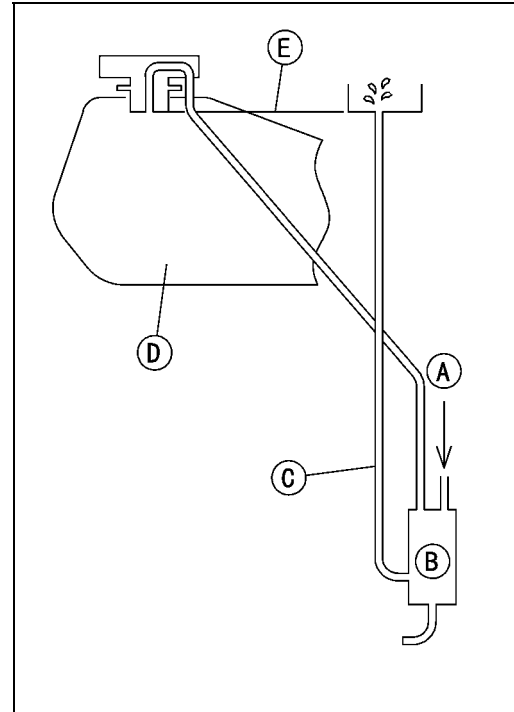

Canister Inspection

- Refer to the Evaporative Emission Control System Inspection in the Periodic Maintenance chapter (see Evaporative Emission Control System Inspection in the Periodic Maintenance chapter).

NOTE

- The canister [A] is designed to work well through the motorcycle's life without any maintenance if it is used under normal conditions.



Cooling System

Table of Contents

Exploded View	4-2
Coolant Flow Chart	4-4
Specifications	4-6
Coolant	4-7
Coolant Deterioration Inspection	4-7
Coolant Level Inspection	4-7
Coolant Draining	4-7
Coolant Filling	4-7
Pressure Testing	4-7
Cooling System Flushing	4-8
Coolant Reserve Tank Removal	4-8
Coolant Reserve Tank Installation	4-9
Water Pump	4-10
Water Pump Removal	4-10
Water Pump Installation	4-10
Water Pump Impeller Inspection	4-11
Radiator	4-12
Radiator and Radiator Fan Removal	4-12
Radiator and Radiator Fan Installation	4-13
Radiator Inspection	4-16
Radiator Cap Inspection	4-16
Radiator Filler Neck Inspection	4-17
Thermostat	4-18
Thermostat Removal	4-18
Thermostat Installation	4-18
Thermostat Inspection	4-19
Hoses and Pipes	4-21
Hose Installation	4-21
Hose Inspection	4-21
Water Temperature Sensor	4-22
Water Temperature Sensor Removal	4-22
Water Temperature Sensor Inspection	4-22

Exploded View

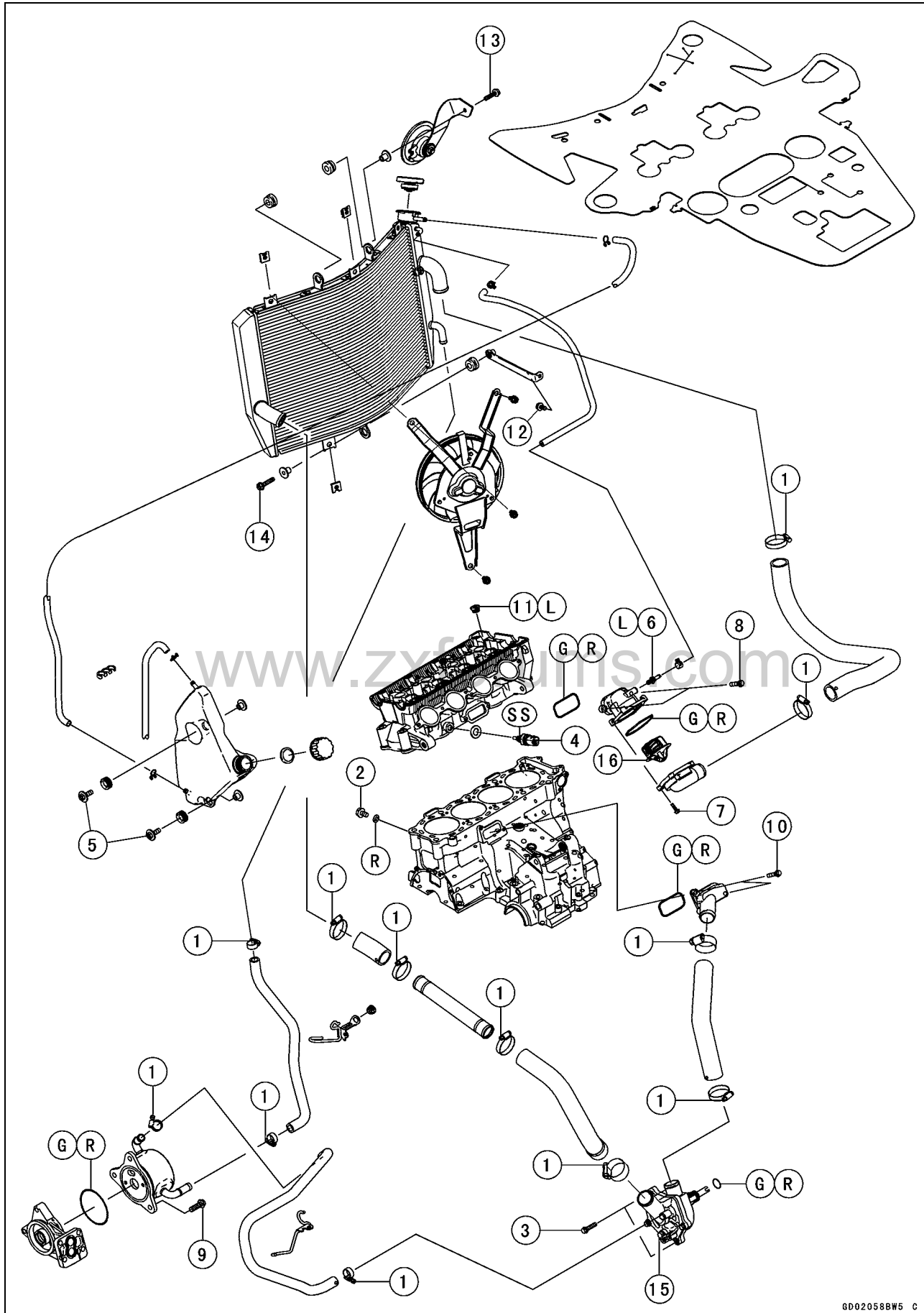

GD02058BW5 C

Exploded View

No.	Fastener	Torque			Remarks
		N·m	kgf·m	ft·lb	
1	Water Hose Clamp Screws	2.0	0.20	18 in·lb	
2	Coolant Drain Bolt (Cylinder)	10	1.0	89 in·lb	
3	Water Pump Cover Bolts	10	1.0	89 in·lb	
4	Water Temperature Sensor	25	2.5	18	SS
5	Coolant Reserve Tank Mounting Bolts	7.0	0.71	62 in·lb	
6	Coolant By-pass Fitting Bolt	9.0	0.92	80 in·lb	L
7	Thermostat Housing Cover Bolts	6.0	0.61	53 in·lb	
8	Thermostat Housing Mounting Bolts	10	1.0	89 in·lb	
9	Oil Cooler Mounting Bolts	20	2.0	15	
10	Water Hose Fitting Bolts	10	1.0	89 in·lb	
11	Water Passage Plugs	19.6	2.0	14	L
12	Radiator Bracket Mounting Bolt	7.0	0.71	62 in·lb	
13	Radiator Upper Bolt	7.0	0.71	62 in·lb	
14	Radiator Lower Bolt	7.0	0.71	62 in·lb	
15	Coolant Drain Bolt (Water Pump)	10	1.0	89 in·lb	

16. Thermostat

G: Apply grease.

L: Apply a non-permanent locking agent.

R: Replacement Parts

SS: Apply silicone sealant.

www.zxforums.com

Coolant Flow Chart

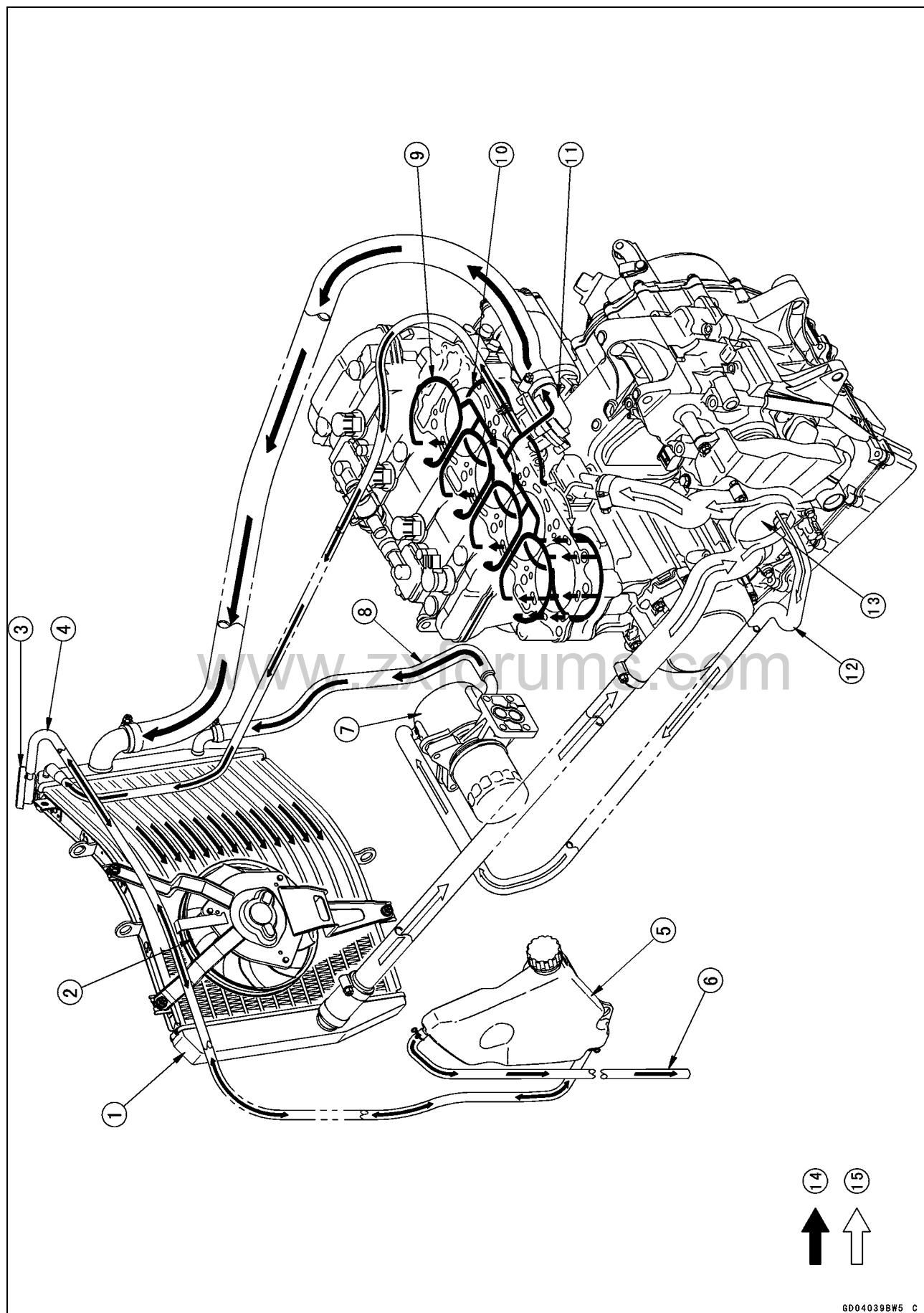

GD04039BW5 C

Coolant Flow Chart

1. Radiator
2. Radiator Fan
3. Radiator Cap
4. Radiator Overflow Hose
5. Reserve Tank
6. Reserve Tank Overflow Hose
7. Oil Cooler
8. Outlet Hose
9. Cylinder Head Jacket
10. Cylinder Jacket
11. Thermostat Housing
12. Inlet Hose
13. Water Pump
14. Hot Coolant
15. Cold Coolant

Permanent type antifreeze is used as a coolant to protect the cooling system from rust and corrosion. When the engine starts, the water pump turns and the coolant circulates.

The thermostat is a wax pellet type which opens or closes with coolant temperature changes. The thermostat continuously changes its valve opening to keep the coolant temperature at the proper level. When coolant temperature is less than 55°C (131°F), the thermostat closes so that the coolant flow is restricted through the air bleeder hole, causing the engine to warm up more quickly. When coolant temperature is more than 58 ~ 62°C (136 ~ 144°F), the thermostat opens and the coolant flows.

When the coolant temperature goes up beyond 95°C (203°F), the radiator fan relay conducts to operate the radiator fan. The radiator fan draws air through the radiator core when there is not sufficient air flow such as at low speeds. This increases up the cooling action of the radiator. When the coolant temperature is below 90°C (194°F), the fan relay opens and the radiator fan stops.

In this way, this system controls the engine temperature within narrow limits where the engine operates most efficiently even if the engine load varies.

The system is pressurized by the radiator cap to suppress boiling and the resultant air bubbles which can cause engine overheating. As the engine warms up, the coolant in the radiator and the water jacket expands. The excess coolant flows through the radiator cap and hose to the reserve tank to be stored there temporarily. Conversely, as the engine cools down, the coolant in the radiator and the water jacket contracts, and the stored coolant flows back to the radiator from the reserve tank.

The radiator cap has two valves. One is a pressure valve which holds the pressure in the system when the engine is running. When the pressure exceeds 93 ~ 123 kPa (0.95 ~ 1.25 kgf/cm², 14 ~ 18 psi), the pressure valve opens and releases the pressure to the reserve tank. As soon as pressure escapes, the valve closes, and keeps the pressure at 93 ~ 123 kPa (0.95 ~ 1.25 kgf/cm², 14 ~ 18 psi). When the engine cools down, another small valve (vacuum valve) in the cap opens. As the coolant cools, the coolant contracts to form a vacuum in the system. The vacuum valve opens and allows the coolant from the reserve tank to enter the radiator.

Specifications

Item	Standard
<p>Coolant Provided when Shipping</p> <p>Type (Recommended)</p> <p>Color</p> <p>Mixed Ratio</p> <p>Freezing Point</p> <p>Total Amount</p>	<p>Permanent type of antifreeze (soft water and ethylene glycol plus corrosion and rust inhibitor chemicals for aluminum engines and radiators)</p> <p>Green</p> <p>Soft water 50%, coolant 50%</p> <p>-35°C (-31°F)</p> <p>2.9 L (3.1 US qt) (Reserve tank full level, including radiator and engine)</p>
<p>Radiator Cap</p> <p>Relief Pressure</p>	<p>93 ~ 123 kPa (0.95 ~ 1.25 kgf/cm², 14 ~ 18 psi)</p>
<p>Thermostat</p> <p>Valve Opening Temperature</p> <p>Valve Full Opening Lift</p>	<p>58 ~ 62°C (136 ~ 144°F)</p> <p>8 mm (0.31 in.) or more at 75°C (167°F)</p>

www.zxforums.com

Coolant

Coolant Deterioration Inspection

- Visually inspect the coolant in the reserve tank.
- ★ If whitish cotton-like wafts are observed, aluminum parts in the cooling system are corroded. If the coolant is brown, iron or steel parts are rusting. In either case, flush the cooling system.
- ★ If the coolant gives off an abnormal smell, check for a cooling system leak. It may be caused by exhaust gas leaking into the cooling system.

Coolant Level Inspection

- Refer to the Coolant Level Inspection in the Periodic Maintenance chapter (see Coolant Level Inspection in the Periodic Maintenance chapter).

Coolant Draining

- Refer to the Coolant Change in the Periodic Maintenance chapter (see Coolant Change in the Periodic Maintenance chapter).

Coolant Filling

- Refer to the Coolant Change in the Periodic Maintenance chapter (see Coolant Change in the Periodic Maintenance chapter).

Pressure Testing

- Remove:
 - Right Upper Inner Fairing (see Upper Inner Fairing Removal in the Frame chapter).
 - Radiator Cap [A]
- Remove the radiator cap in two steps. First turn the cap counterclockwise to the first stop. Then push and turn it further in the same direction and remove the cap.

- Install the cooling system pressure tester [A] on the filler neck.

NOTE

- Wet the cap sealing surfaces with water or coolant to prevent pressure leaks.

- Build up pressure in the system carefully until the pressure reaches 123 kPa (1.25 kgf/cm², 18 psi).

CAUTION

During pressure testing, do not exceed the pressure for which the system is designed. The maximum pressure is 123 kPa (1.25 kgf/cm², 18 psi).

- Watch the gauge for at least 6 seconds.
- ★ If the pressure holds steady, the system is all right.
- ★ If the pressure drops and no external source is found, check for internal leaks. Droplets in the engine oil indicate internal leakage. Check the cylinder head gasket and the water pump.
- Remove the pressure tester, replenish the coolant, and install the radiator cap.

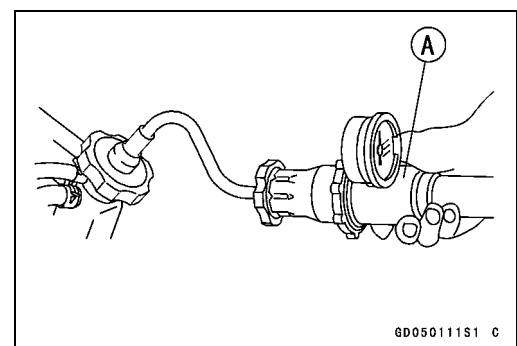

Coolant

Cooling System Flushing

Over a period of time, the cooling system accumulates rust, scale, and lime in the water jacket and radiator. When this accumulation is suspected or observed, flush the cooling system. If this accumulation is not removed, it will clog up the water passage and considerably reduce the efficiency of the cooling system.

- Drain the cooling system (see Coolant Change in the Periodic Maintenance chapter).
- Fill the cooling system with fresh water mixed with a flushing compound.

CAUTION

Do not use a flushing compound which is harmful to the aluminum engine and radiator. Carefully follow the instructions supplied by the manufacturer of the cleaning product.

- Warm up the engine, and run it at normal operating temperature for about ten minutes.
- Stop the engine, and drain the cooling system.
- Fill the system with fresh water.
- Warm up the engine and drain the system.
- Repeat the previous two steps once more.
- Fill the system with a permanent type coolant and bleed the air from the system (see Coolant Change in the Periodic Maintenance chapter).

Coolant Reserve Tank Removal

- Remove:
 - Left Middle Fairing (see Middle Fairing Removal in the Frame chapter)
 - Coolant Reserve Tank Mounting Bolts [A]
- Remove the cap [B] and pour the coolant into a container.
- Remove:
 - Radiator Overflow Hose [C]
 - Reserve Tank Overflow Hose [D]
 - Coolant Reserve Tank [E]

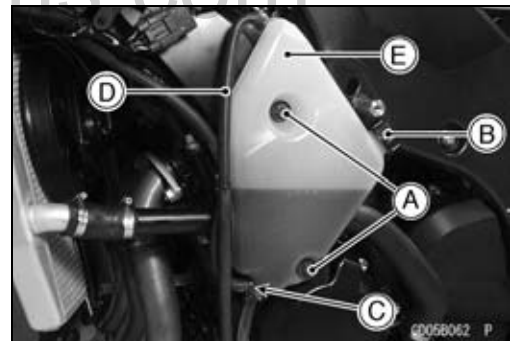

Coolant

Coolant Reserve Tank Installation

- Install the following to the coolant reserve tank [A].
 - Rubber Dampers [B]
 - Collars [C]
 - Gasket [D]
 - Cap [E]
- Tighten:
 - Torque - Coolant Reserve Tank Mounting Bolts [F]: 7.0 N·m (0.71 kgf·m, 62 in·lb)**
- Run the hoses correctly (see Cable, Wire, and Hose Routing section in the Appendix chapter).
- Fill the coolant reserve tank with coolant (see Coolant Change in the Periodic Maintenance chapter).

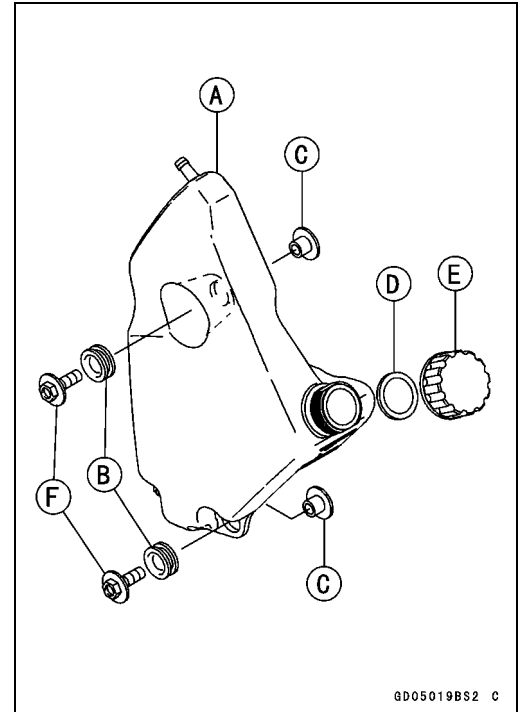

GD05019BS2 C

www.zxforums.com

Water Pump

Water Pump Removal

- Drain:
 - Coolant (see Coolant Change in the Periodic Maintenance chapter)
 - Engine Oil (see Engine Oil Change in the Periodic Maintenance chapter)
- Remove the water hoses [A].

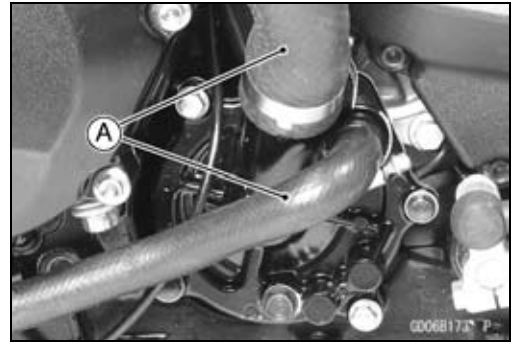

- Remove:
 - Water Pump Cover Bolts [A]
 - Water Pump Cover [B]

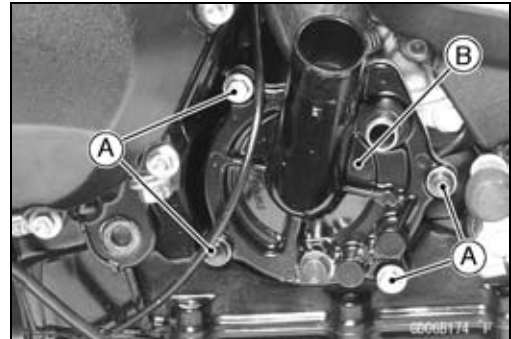

- Remove the water hose [A].
- Remove the water pump body [B] with impeller [C].

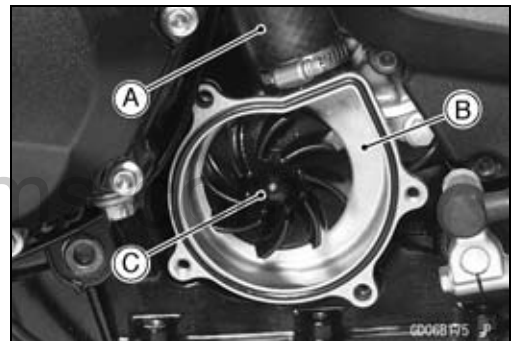

www.zxforum

Water Pump Installation

- Replace the O-ring [A] with a new one.
- Apply grease to the new O-ring.



- Route the gear position switch lead [A] as shown.

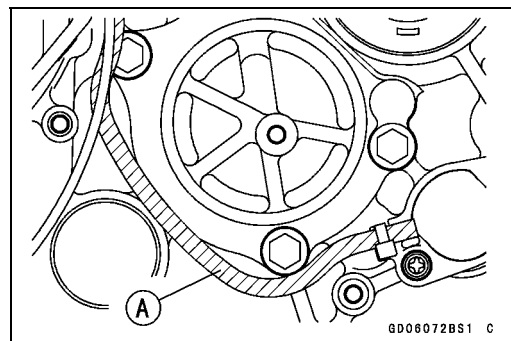

Water Pump

- Turn the impeller shaft so that the slot [A] in its shaft fits onto the projection [B] of the oil pump gear shaft.

CAUTION

Do not pinch the gear position switch lead.

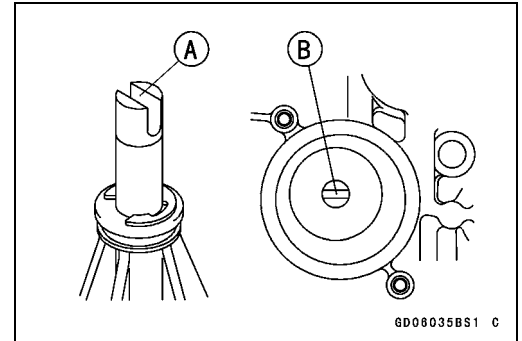

- Install the water hose [A] and hose clamp [B] as shown.
White Mark [C]
- Tighten:
Torque - Water Hose Clamp Screw: 2.0 N·m (0.20 kgf·m, 18 in·lb)

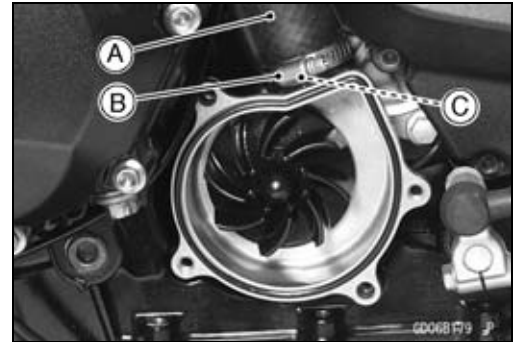

- Install the water pump cover [A].
Torque - Water Pump Cover Bolts: 1.0 N·m (1.0 kgf·m, 89 in·lb)
- Align the line [B] of the water pump cover and the white mark [C] of the water hose [D].
- Install the water hose [E] clamps [F] as shown.
White Mark [G]
- Tighten:
Torque - Water Hose Clamp Screw: 2.0 N·m (0.20 kgf·m, 18 in·lb)

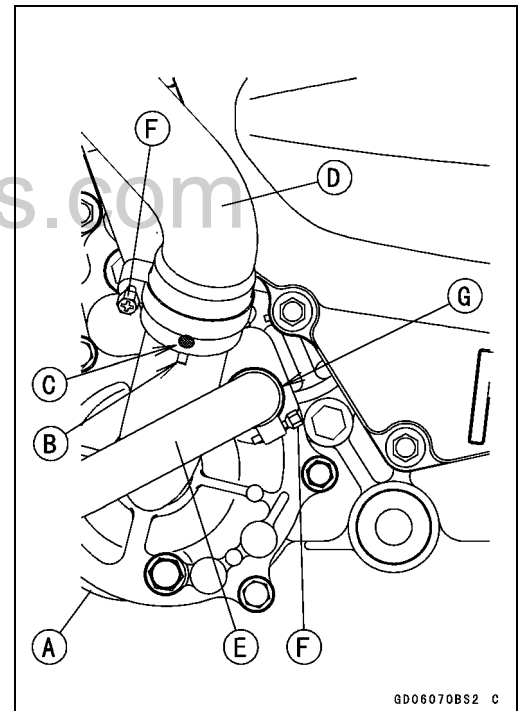

Water Pump Impeller Inspection

- Remove the water pump cover (see Water Pump Removal).
- Visually inspect the water pump impeller [A].
- ★ If the surface is corroded or if the blades are damaged, replace the water pump assy.



Radiator

Radiator and Radiator Fan Removal

- Drain the coolant (see Coolant Change in the Periodic Maintenance chapter).
- Remove:
 - Right Middle Fairing (see Middle Fairing Removal in the Frame chapter)
 - Separator [A] (California Model)
 - Clamp [B] (California Model)
 - Radiator Cap [C]
 - Radiator Hoses [D]
 - Radiator Upper Bolt [E]
 - Horn [F]
- Remove:
 - Radiator Lower Bolt [A]
 - Radiator Fan Lead Connector [B]
 - Radiator Hose [C]
- Pull the radiator from the projection [D], and remove the radiator.

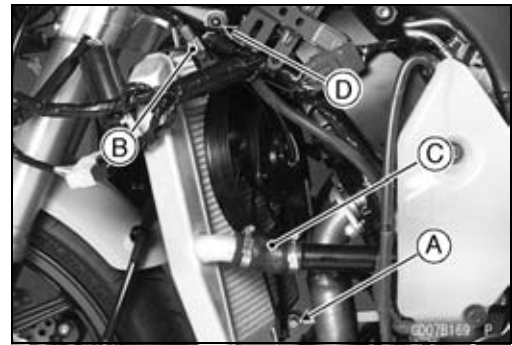
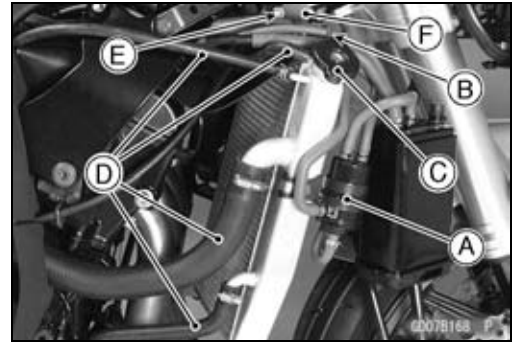

CAUTION

Do not touch the radiator core. This could damage the radiator fins, resulting in loss of cooling efficiency.

- Remove the bolt [A] and radiator bracket [B] as necessary.

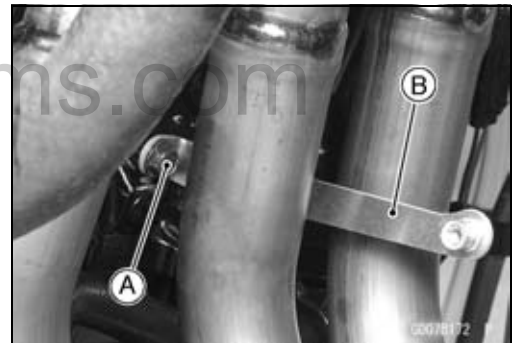

- Remove:
 - Radiator Fan Mounting Bolts [A]
 - Radiator Fan [B]

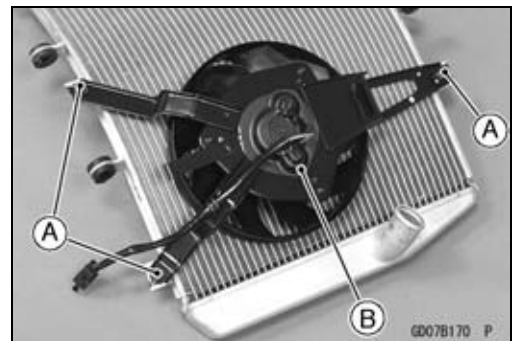

Radiator

Radiator and Radiator Fan Installation

- Install the radiator fan [A].
- Install the rubber dampers [B] and collars [C] as shown.

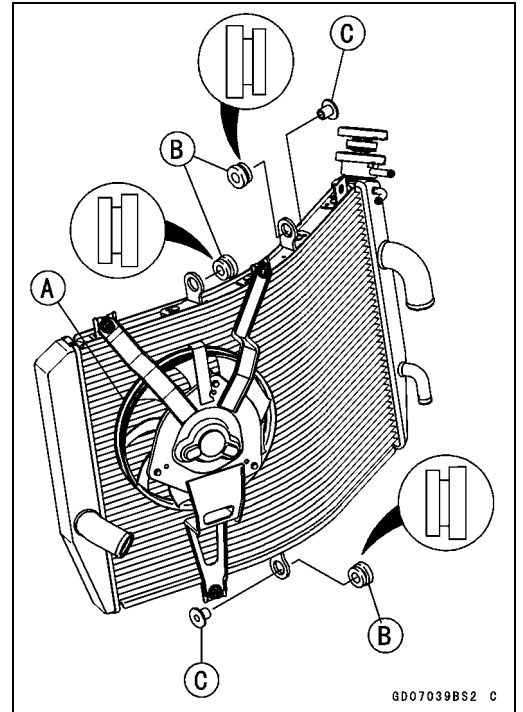

- Remove the radiator cap [A] temporarily.
- Cover the heat insulation rubber plate [B] on the radiator [C] as shown.
- Reinstall the radiator cap.
- Trough the radiator fan lead [D] in the heat insulation rubber plate hole [E].
- Connect radiator fan lead connector.

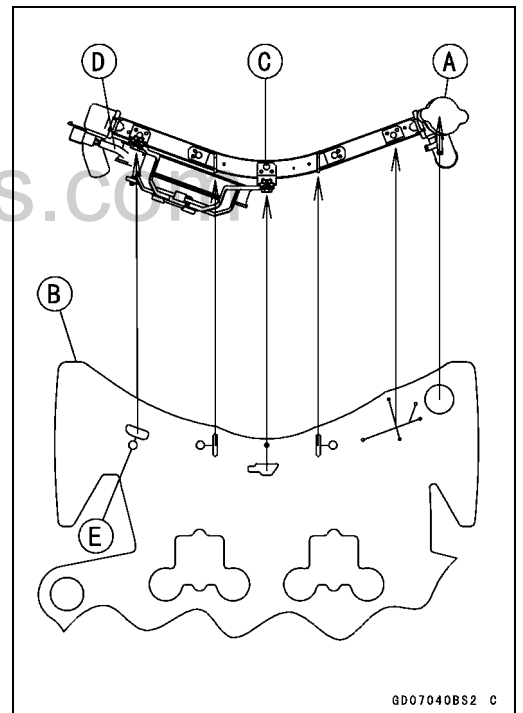

- Install the radiator in the projection [A] as shown.

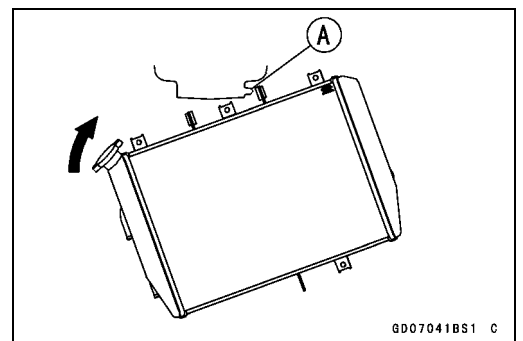

Radiator

★ If the radiator bracket [A] was removed, install it.

Torque - Radiator Bracket Mounting Bolt [B]: 7.0 N·m (0.71 kgf·m, 62 in·lb)

● Tighten:

Torque - Radiator Lower Bolt [C]: 7.0 N·m (0.71 kgf·m, 62 in·lb)

Radiator Upper Bolt [D]: 7.0 N·m (0.71 kgf·m, 62 in·lb)

Horn [E]

● Face the white mark [F] of the radiator hose [G] direction as shown.

● Install the water hose clamp [H].

Torque - Water Hose Clamp Screw: 2.0 N·m (0.20 kgf·m, 18 in·lb)

● Run the coolant return hose [I] under the heat insulation rubber plate and install it.

● Run the radiator overflow hose [J] over the heat insulation rubber plate and install it.

● For the California Model, install the separator [K] and clamp [L].

Torque - Separator Bracket Mounting Bolt [M]: 7.0 N·m (0.71 kgf·m, 62 in·lb)

Canister/Separator Hose Clamp Bolt [N]: 7.0 N·m (0.71 kgf·m, 62 in·lb)

○ Route the canister and separator hoses according to Cable, Wire, and Hose Routing section in the Appendix chapter.

Radiator

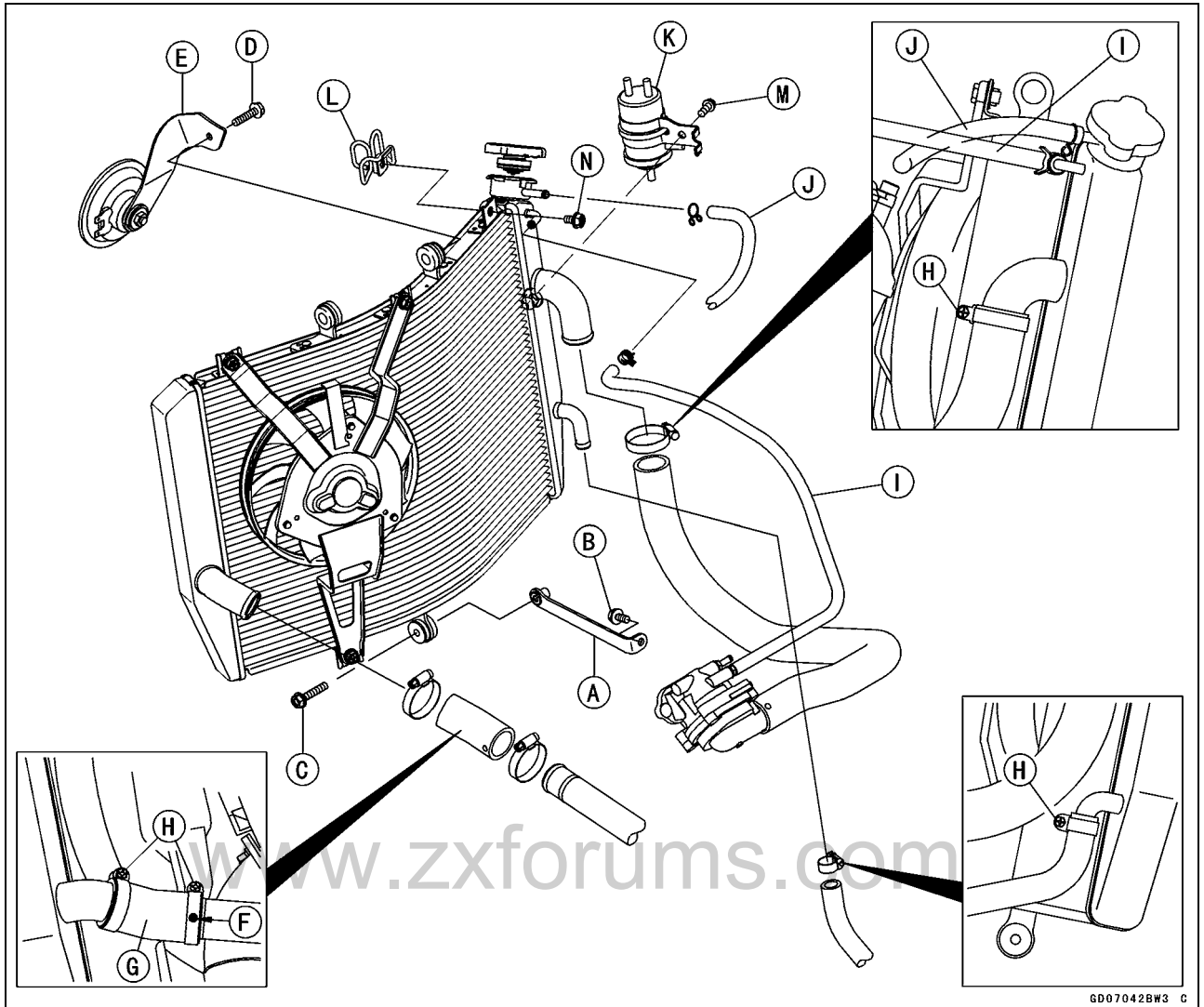

GD07042BW3 C

- Fill the radiator with coolant (see Coolant Change in the Periodic Maintenance chapter).
- Install the middle fairings (see Middle Fairings Installation in the Frame chapter).
- After installation, note the following.
 - Run the main harness [A] over the heat insulation rubber plate [B].
 - Put the edges of the heat insulation rubber plate on the hole of the middle fairings [C].

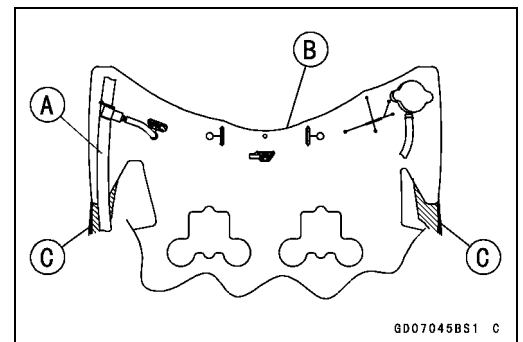

GD07045BS1 C

Radiator

Radiator Inspection

- Remove the radiator (see Radiator and Radiator Fan Removal).
- Check the radiator core.
- ★ If there are obstructions to air flow, remove them.
- ★ If the corrugated fins [A] are deformed, carefully straighten them.
- ★ If the air passages of the radiator core are blocked more than 20% by unremovable obstructions or irreparably deformed fins, replace the radiator with a new one.

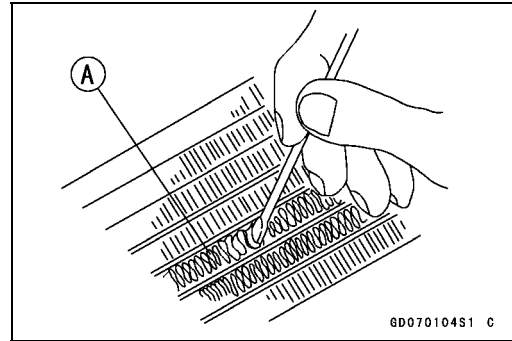

CAUTION

When cleaning the radiator with steam cleaner, be careful of the following to prevent radiator damage: Keep the steam gun [A] away more than 0.5 m (1.6 ft) [B] from the radiator core. Hold the steam gun perpendicular [C] (not oblique [D]) to the core surface. Run the steam gun, following the core fin direction.

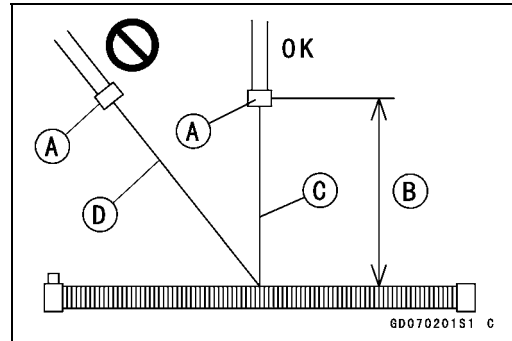

Radiator Cap Inspection

- Remove the radiator cap (see Pressure Testing).
- Check the condition of the bottom [A] and top [B] valve seals and valve spring [C].
- ★ If any one of them shows visible damage, replace the cap with a new one.

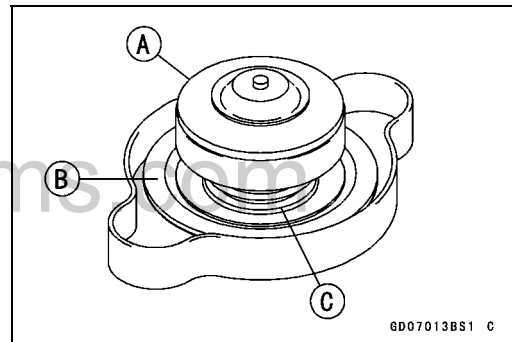

- Install the cap [A] on a cooling system pressure tester [B].

NOTE

○ Wet the cap sealing surfaces with water or coolant to prevent pressure leaks.

- Watching the pressure gauge, pump the pressure tester to build up the pressure until the relief valve opens: the gauge needle flicks downward. Stop pumping and measure leak time at once. The relief valve must open within the specified range in the table below and the gauge hand must remain within the same range at least 6 seconds.

Radiator Cap Relief Pressure

Standard: 93 ~ 123 kPa (0.95 ~ 1.25 kgf/cm², 14 ~ 18 psi)

- ★ If the cap can not hold the specified pressure or if it holds too much pressure, replace it with a new one.

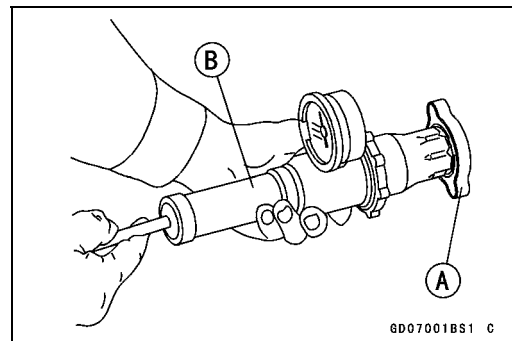

Radiator

Radiator Filler Neck Inspection

- Remove the radiator cap (see Pressure Testing).
- Check the radiator filler neck for signs of damage.
- Check the condition of the top and bottom sealing seats [A] in the filler neck. They must be smooth and clean for the radiator cap to function properly.

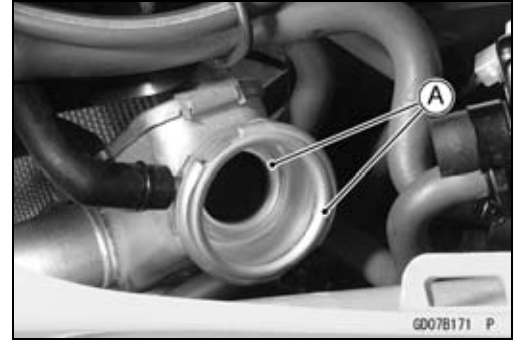

www.zxforums.com

Thermostat

Thermostat Removal

- Drain the coolant (see Coolant Change in the Periodic Maintenance chapter).
- Remove:
 - Fuel Tank (see Fuel Tank Removal in the Fuel System (DFI) chapter)
 - Air Cleaner Housing (see Air Cleaner Housing Removal in the Fuel System (DFI) chapter)
 - Throttle Body Assy (see Throttle Body Assy Removal in the Fuel System (DFI) chapter)
 - Water Hoses [A]
 - Thermostat Housing Mounting Bolts [B]
- Remove:
 - Thermostat Housing Cover Bolts [A]
 - Thermostat Housing Cover [B]
 - Thermostat
- Remove the coolant by-pass fitting bolt [C] as necessary.

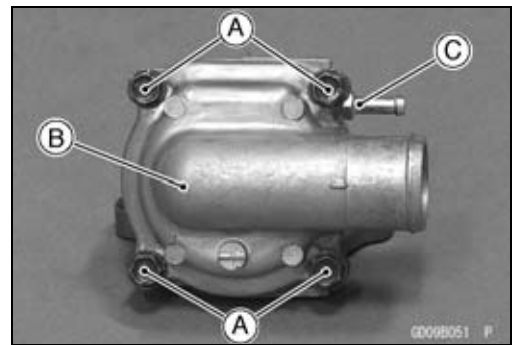
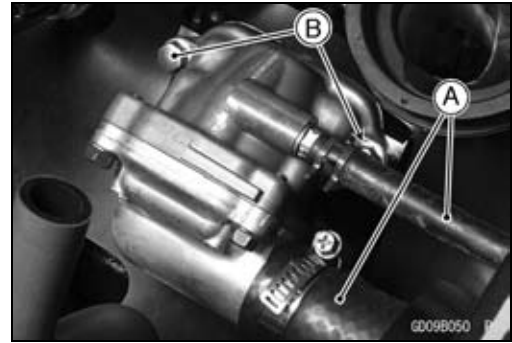

Thermostat Installation

- Install the thermostat [A] in the housing so that the air bleeder hole [B] is on top.

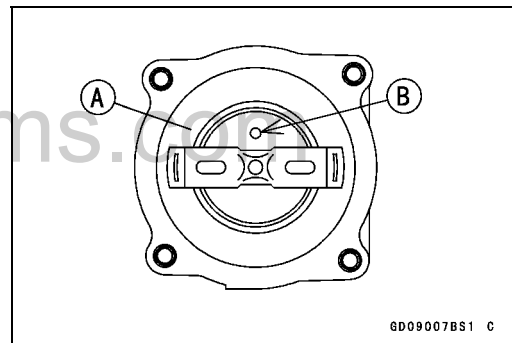

Thermostat

- Replace the O-rings [A] with a new one.
- Apply grease to the new O-rings.
- Install a new O-rings into the thermostat housing [B] and Cover [C].
- ★ If the coolant by-pass fitting bolt [D] was removed, install it.
- Apply a non-permanent locking agent to the threads of the coolant by-pass fitting bolt, and tighten it.

Torque - Coolant By-pass Fitting Bolt: 9.0 N·m (0.92 kgf·m, 80 in·lb)

- Tighten the thermostat housing cover bolts [E].

Torque - Thermostat Housing Cover Bolts: 6.0 N·m (0.60 kgf·m, 53 in·lb)

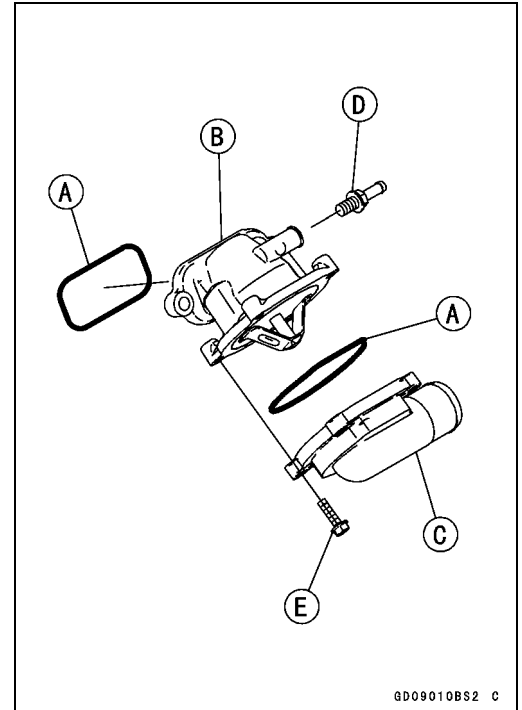

- Install the thermostat housing.

Torque - Thermostat Housing Mounting Bolts: 10 N·m (1.0 kgf·m, 89 in·lb)

- Align the thermostat housing cover bolt [A] and white mark [B] of water hose [C].
- Install the water hose clamp [D].

Torque - Water Hose Clamp Screw: 2.0 N·m (0.20 kgf·m, 18 in·lb)

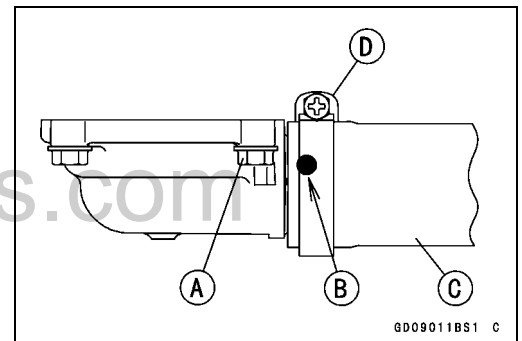

- Install the removed parts (see appropriate chapters).
- Fill the radiator with coolant (see Coolant Change in the Periodic Maintenance chapter).

Thermostat Inspection

- Remove the thermostat (see Thermostat Removal).
- Inspect the thermostat valve [A] at room temperature.
- ★ If the valve is open, replace the thermostat with a new one.

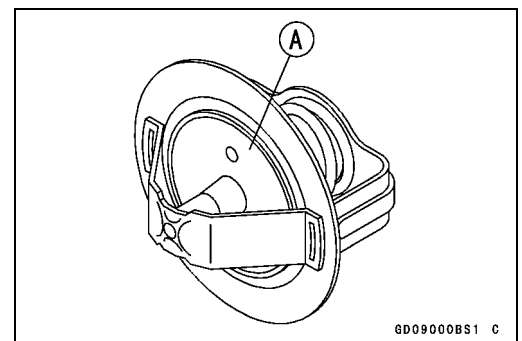

Thermostat

- To check valve opening temperature, suspend the thermostat [A] in a container of water and raise the temperature of the water.
- The thermostat must be completely submerged and must not touch the container sides or bottom. Suspend an accurate thermometer [B] in the water so that the heat sensitive portions [C] are located in almost the same depth.
- ★ If the measurement is out of the specified range, replace the thermostat with a new one.

Thermostat Valve Opening Temperature
58 ~ 62°C (136 ~ 144°F)

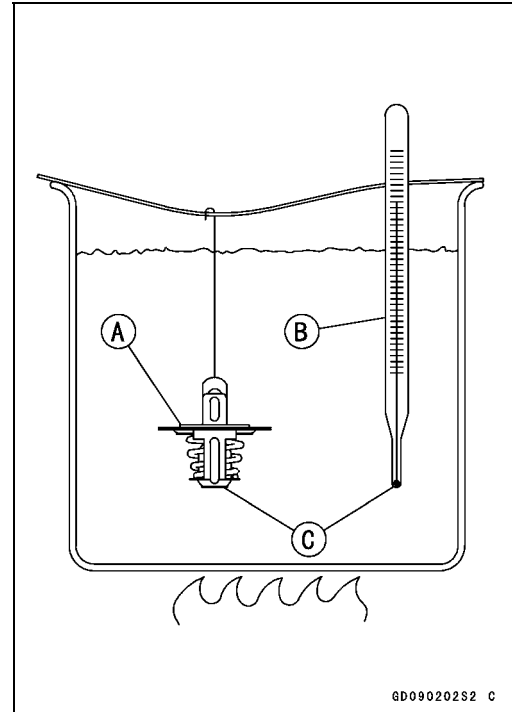

Hoses and Pipes

Hose Installation

- Install the hoses and pipes, being careful to follow bending direction. Avoid sharp bending, kinking, flattening or twisting.
- Run the hoses in accordance with the Cable, Wire, and Hose Routing section in the Appendix chapter.
- Install the clamp [A] as near as possible to the hose end to clear the raised rib of the fitting. This will prevent the hoses from working loose.
- The clamp screws should be positioned correctly to prevent the clamps from contacting the other parts.

Torque - Water Hose Clamp Screws: 2.0 N·m (0.20 kgf·m, 18 in·lb)

Hose Inspection

- Refer to the Radiator Hose and Connection Inspection in the Periodic Maintenance chapter (see Radiator Hose and Connection Inspection in the Periodic Maintenance chapter).

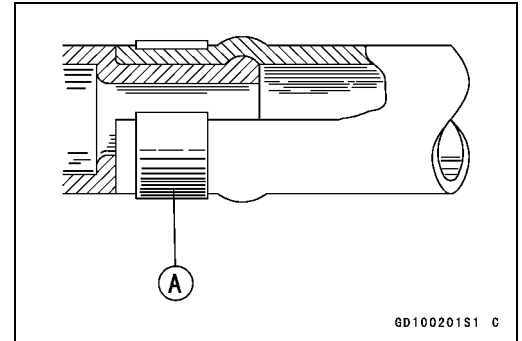

Water Temperature Sensor

CAUTION

The water temperature sensor should never be allowed to fall on a hard surface. Such a shock to their parts can damage them.

Water Temperature Sensor Removal

- Refer to the Water Temperature Sensor Removal in the Fuel System (DFI) chapter (Water Temperature Sensor Removal in the Fuel System (DFI) chapter).
Water Temperature Sensor [A]



Water Temperature Sensor Inspection

- Refer to the Water Temperature Sensor Inspection in the Electrical System chapter (Water Temperature Sensor Inspection in the Electrical System chapter).

Engine Top End

Table of Contents

Exploded View.....	5-3
Exhaust System.....	5-8
Specifications	5-11
Special Tools and Sealant.....	5-12
Clean Air System.....	5-14
Air Suction Valve Removal.....	5-14
Air Suction Valve Installation.....	5-14
Air Suction Valve Inspection	5-14
Air Switching Valve Removal	5-15
Air Switching Valve Installation	5-15
Air Switching Valve Operation Test.....	5-15
Air Switching Valve Unit Test	5-15
Clean Air System Hose Inspection	5-15
Cylinder Head Cover	5-16
Cylinder Head Cover Removal	5-16
Cylinder Head Cover Installation	5-16
Camshaft Chain Tensioner	5-18
Camshaft Chain Tensioner Removal	5-18
Camshaft Chain Tensioner Installation.....	5-19
Camshaft, Camshaft Chain	5-20
Camshaft Removal	5-20
Camshaft Installation	5-21
Camshaft, Camshaft Cap Wear	5-25
Camshaft Runout.....	5-25
Cam Wear.....	5-26
Camshaft Chain Removal.....	5-26
Cylinder Head.....	5-27
Cylinder Compression Measurement.....	5-27
Cylinder Head Removal.....	5-28
Cylinder Head Installation	5-29
Cylinder Head Warp.....	5-30
Valves	5-31
Valve Clearance Inspection	5-31
Valve Removal.....	5-31
Valve Installation	5-31
Valve Guide Removal	5-31
Valve Guide Installation	5-32
Valve-to-Guide Clearance Measurement (Wobble Method)	5-32
Valve Seat Inspection	5-33
Valve Seat Repair	5-33
Throttle Body Assy Holder.....	5-38
Throttle Body Assy Holder Removal.....	5-38
Throttle Body Assy Holder Installation	5-38
Muffler.....	5-39
Muffler Body Removal.....	5-39
Muffler Body Installation.....	5-40
Middle and Rear Exhaust Pipe Removal	5-41
Middle and Rear Exhaust Pipe Installation	5-42
Front Exhaust Pipe Removal	5-43
Front Exhaust Pipe Installation	5-44

Exhaust Butterfly Valve Cable Removal	5-45
Exhaust Butterfly Valve Cable Installation	5-46

www.zxforums.com

Exploded View

Dummy Page

www.zxforums.com

Exploded View

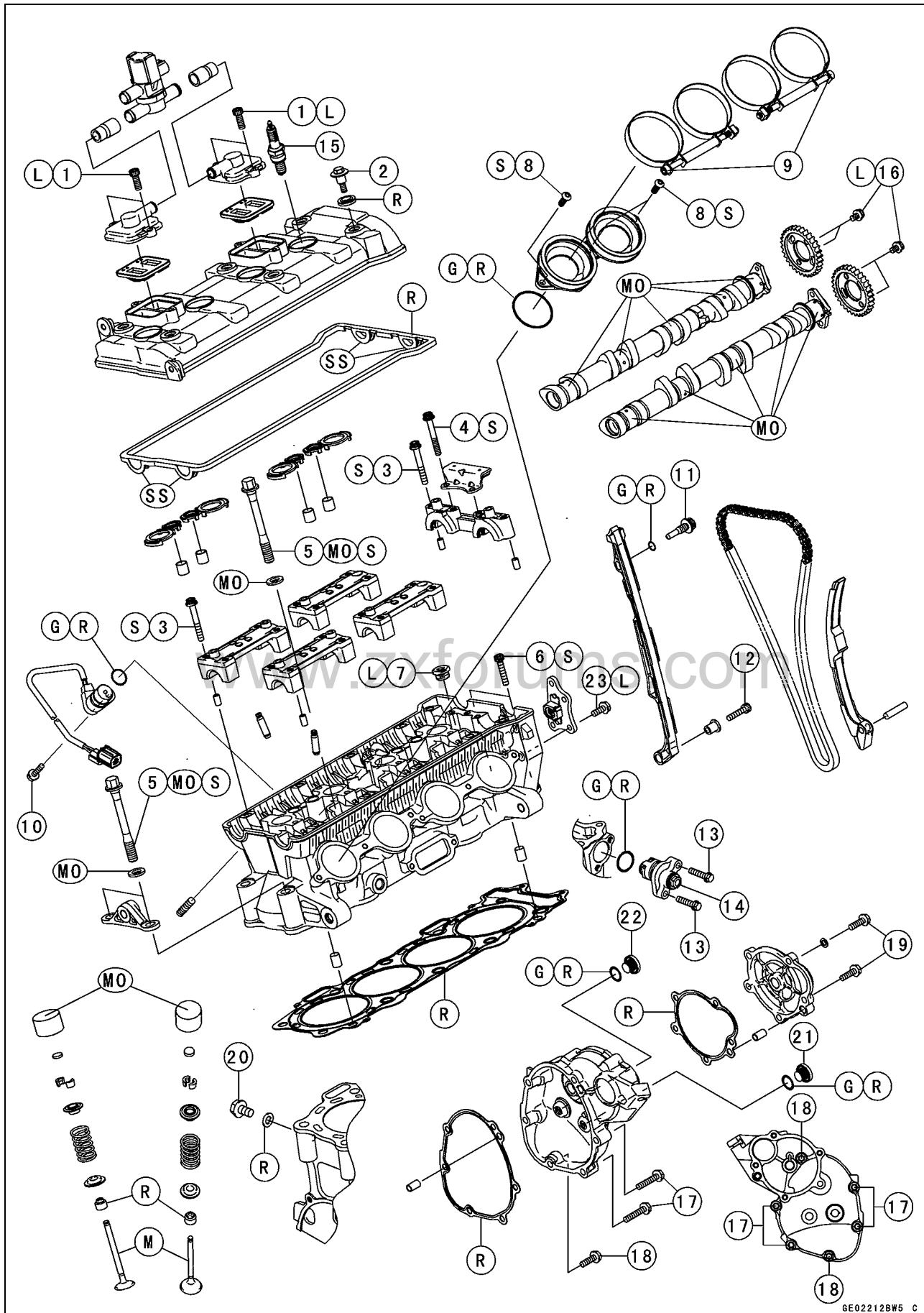

GE02212BW5 C

Exploded View

No.	Fastener	Torque			Remarks
		N·m	kgf·m	ft·lb	
1	Air Suction Valve Cover Bolts	10	1.0	89 in·lb	L
2	Cylinder Head Cover Bolts	10	1.0	89 in·lb	
3	Camshaft Cap Bolts	12	1.2	106 in·lb	S
4	Upper Camshaft Chain Guide Bolts	12	1.2	106 in·lb	S
5	Cylinder Head Bolts (M10 New Bolts)	59	6.0	44	MO, S
5	Cylinder Head Bolts (M10 Used Bolts)	57	5.8	42	MO, S
6	Cylinder Head Bolts (M6)	12	1.2	106 in·lb	S
7	Water Passage Plugs	19.6	2.0	14	L
8	Throttle Body Assy Holder Bolts	10	1.0	89 in·lb	S
9	Throttle Body Assy Holder Clamp Bolts	2.0	0.20	18 in·lb	
10	Camshaft Position Sensor Bolt	10	1.0	89 in·lb	
11	Front Camshaft Chain Guide Bolt (Upper)	25	2.5	18	
12	Front Camshaft Chain Guide Bolt (Lower)	12	1.2	106 in·lb	
13	Camshaft Chain Tensioner Mounting Bolts	10	1.0	89 in·lb	
14	Camshaft Chain Tensioner Cap Bolt	20	2.0	15	
15	Spark Plugs	13	1.3	115 in·lb	
16	Cam Sprocket Mounting Bolts	15	1.5	11	L
17	Starter Clutch Cover Bolts (M6, L = 30)	10	1.0	89 in·lb	
18	Starter Clutch Cover Bolts (M6, L = 20)	10	1.0	89 in·lb	
19	Idle Gear Cover Bolts	10	1.0	89 in·lb	
20	Coolant Drain Plug (Cylinder)	10	1.0	89 in·lb	
21	Starter Clutch Bolt Cap	–	–	–	Hand-tighten
22	Timing Inspection Cap	–	–	–	Hand-tighten
23	Right Engine Bracket Bolts (Cylinder Head Side)	10	1.0	89 in·lb	L

G: Apply grease.

L: Apply a non-permanent locking agent.

M: Apply molybdenum disulfide grease.

MO: Apply molybdenum disulfide oil solution.

(mixture of the engine oil and molybdenum disulfide grease in a weight ratio 10 : 1)

R: Replacement Parts

S: Follow the specified tightening sequence.

SS: Apply silicone sealant (Kawasaki Bond: 92104-0004).

Exploded View

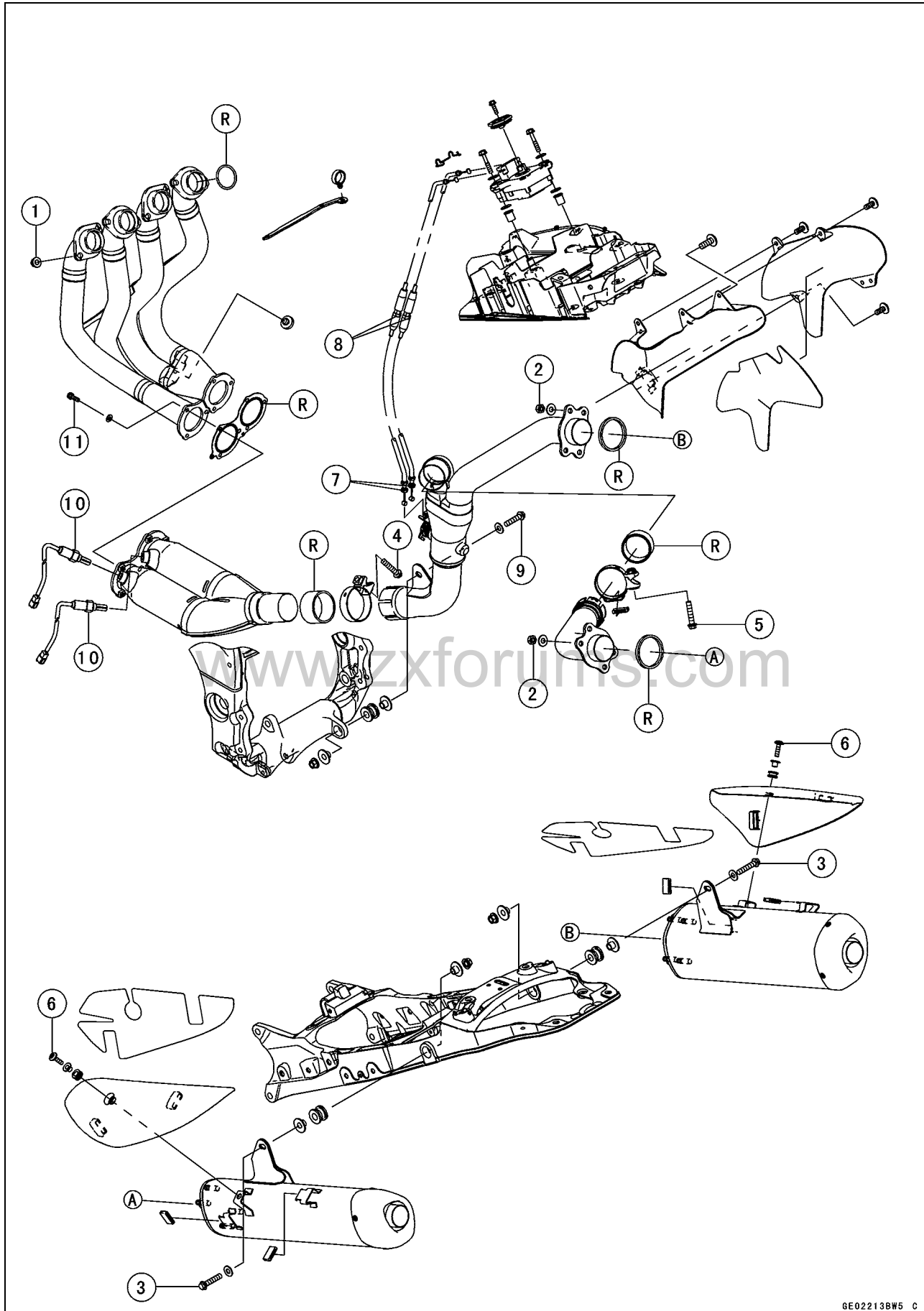

GE02213BW5 C

Exploded View

No.	Fastener	Torque			Remarks
		N·m	kgf·m	ft·lb	
1	Front Exhaust Pipe Holder Nuts	17	1.7	13	
2	Muffler Body Assembly Nuts	22	2.2	16	
3	Muffler Body Mounting Bolts	25	2.5	18	
4	Middle Exhaust Pipe Clamp Bolt	17	1.7	13	
5	Rear Exhaust Pipe Clamp Bolt	17	1.7	13	
6	Muffler Body Cover Bolts	7.0	0.71	62 in·lb	
7	Exhaust Butterfly Valve Cable Locknuts	7.0	0.71	62 in·lb	
8	Exhaust Butterfly Valve Cable Adjuster Locknuts	7.0	0.71	62 in·lb	
9	Middle Exhaust Pipe Stay Bolt	25	2.5	18	
10	Oxygen Sensors (Europe Models)	25	2.5	18	
11	Exhaust Pipe Manifold Mounting Bolts	14	1.4	10	

R: Replacement Parts

www.zxforums.com

Exhaust System

Exhaust System ZX1000D6F

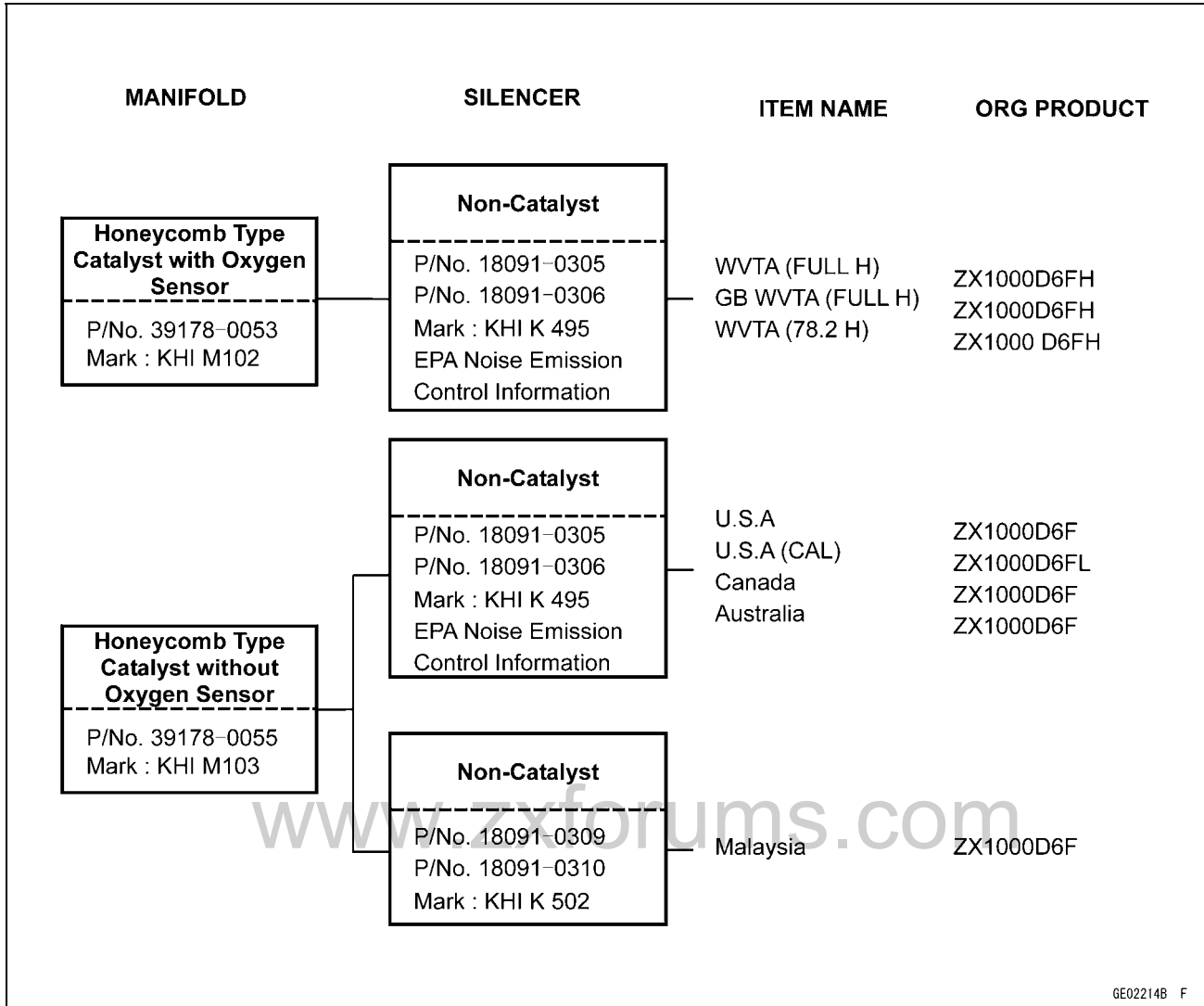

GE02214B F

78.2: Horsepower 78.2 kW (106.3 ps)

Full: Full Power

H: Honeycomb Type Catalyst

Exhaust System

Manifold Mark Position [A]

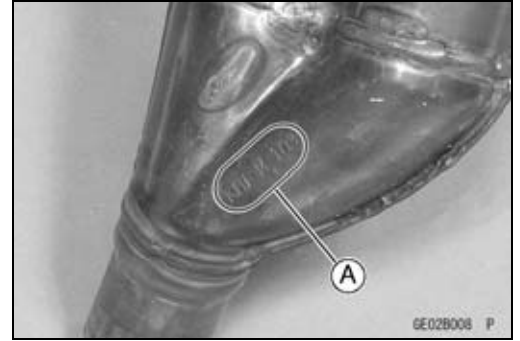

Silencer Mark Position [A]



Manifold [A] with Holes [B] for Oxygen Sensors.
Oxygen Sensor #1 [C]
Oxygen Sensor #2 [D]

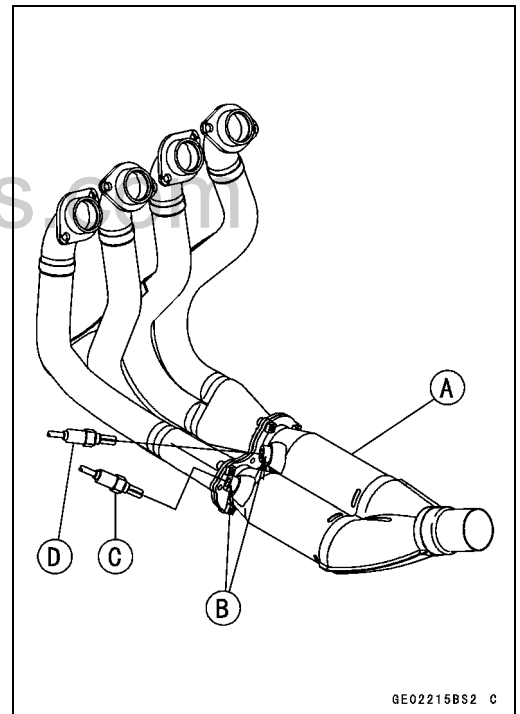

Exhaust System

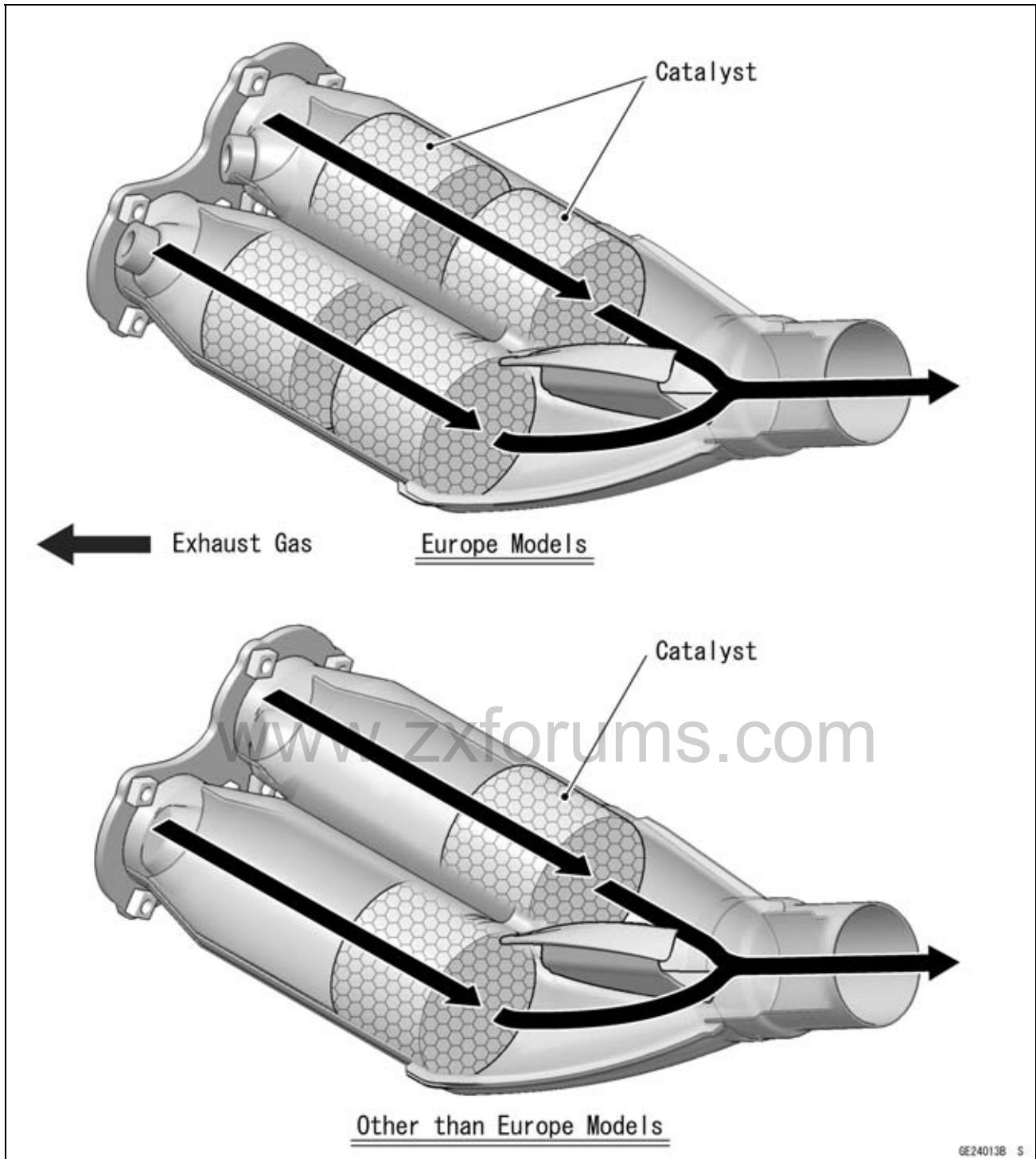

Specifications

Item	Standard	Service Limit
Camshafts		
Cam Height:		
Exhaust	34.443 ~ 34.557 mm (1.3560 ~ 1.3605 in.)	34.34 mm (1.352 in.)
Inlet	35.043 ~ 35.157 mm (1.3796 ~ 1.3841 in.)	34.94 mm (1.376 in.)
Camshaft Journal, Camshaft Cap Clearance	0.038 ~ 0.081 mm (0.0015 ~ 0.0032 in.)	0.17 mm (0.0067 in.)
Camshaft Journal Diameter	23.940 ~ 23.962 mm (0.9425 ~ 0.9434 in.)	23.91 mm (0.941 in.)
Camshaft Bearing Inside Diameter	24.000 ~ 24.021 mm (0.9449 ~ 0.9457 in.)	24.08 mm (0.948 in.)
Camshaft Runout	TIR 0.02 mm (0.0008 in.) or less	TIR 0.1 mm (0.004 in.)
Cylinder Head		
Cylinder Compression	(Usable Range) 1 100 ~ 1 670 kPa (11.2 ~ 17.0 kgf/cm ² , 159 ~ 242 psi) at 320 r/min (rpm)	— — —
Cylinder Head Warp	— — —	0.05 mm (0.002 in.)
Valves		
Valve Clearance:		
Exhaust	0.17 ~ 0.22 mm (0.0067 ~ 0.0087 in.)	— — —
Inlet	0.15 ~ 0.24 mm (0.0059 ~ 0.0094 in.)	— — —
Valve Head Thickness:		
Exhaust	0.8 mm (0.031 in.)	0.4 mm (0.016 in.)
Inlet	0.5 mm (0.020 in.)	0.25 mm (0.001 in.)
Valve Stem Bend	TIR 0.01 mm (0.0004 in.) or less	TIR 0.05 mm (0.002 in.)
Valve Stem Diameter:		
Exhaust	4.470 ~ 4.485 mm (0.1760 ~ 0.1766 in.)	4.46 mm (0.176 in.)
Inlet	4.475 ~ 4.490 mm (0.1762 ~ 0.1768 in.)	4.46 mm (0.176 in.)
Valve Guide Inside Diameter:		
Exhaust	4.500 ~ 4.512 mm (0.1772 ~ 0.1776 in.)	4.58 mm (0.180 in.)
Inlet	4.500 ~ 4.512 mm (0.1772 ~ 0.1776 in.)	4.58 mm (0.180 in.)
Valve/valve Guide Clearance (Wobble Method):		
Exhaust	0.04 ~ 0.12 mm (0.0016 ~ 0.0047 in.)	0.34 mm (0.013 in.)
Inlet	0.03 ~ 0.10 mm (0.0012 ~ 0.0039 in.)	0.34 mm (0.013 in.)
Valve Seat Cutting Angle	45°, 32°, 60°	— — —
Valve Seating Surface:		
Width:		
Exhaust	0.8 ~ 1.2 mm (0.031 ~ 0.047 in.)	— — —
Inlet	0.5 ~ 1.0 mm (0.020 ~ 0.039 in.)	— — —
Outside Diameter:		
Exhaust	24.9 ~ 25.1 mm (0.980 ~ 0.988 in.)	— — —
Inlet	29.4 ~ 29.6 mm (1.157 ~ 1.165 in.)	— — —
Valve Spring Free Length:		
Exhaust	44.78 mm (1.763 in.)	42.9 mm (1.689 in.)
Inlet	39.15 mm (1.541 in.)	37.5 mm (1.476 in.)

Special Tools and Sealant

Compression Gauge, 20 kgf/cm²:
57001-221

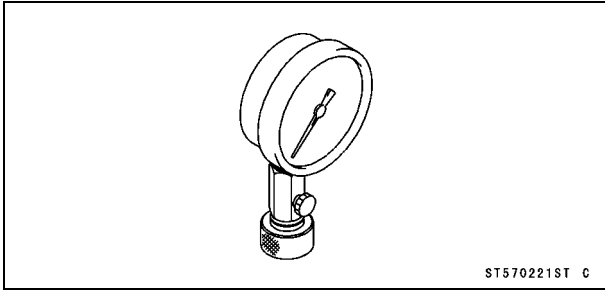

Valve Seat Cutter, 32° - ϕ 35:
57001-1121

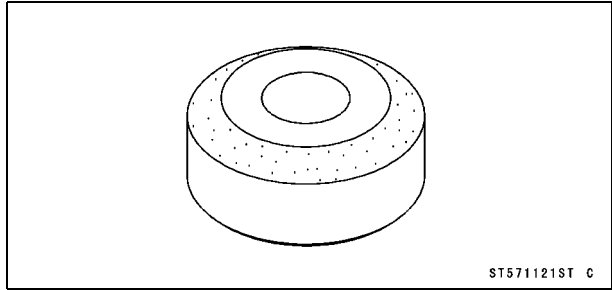

Valve Spring Compressor Assembly:
57001-241

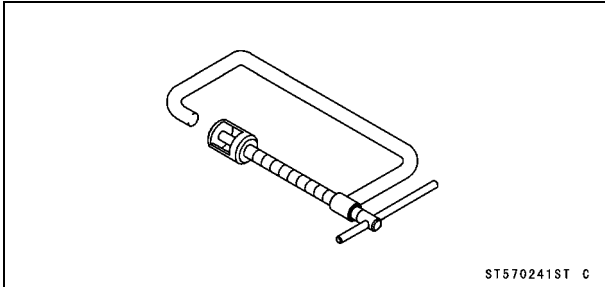

Valve Seat Cutter Holder Bar:
57001-1128

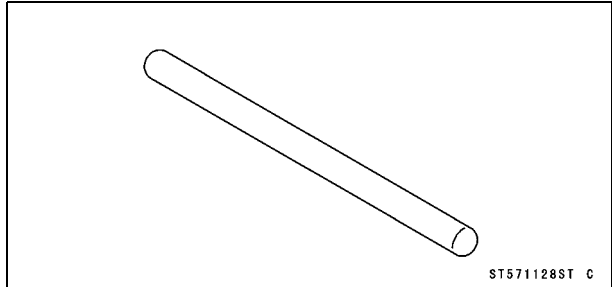

Valve Seat Cutter, 45° - ϕ 27.5:
57001-1114

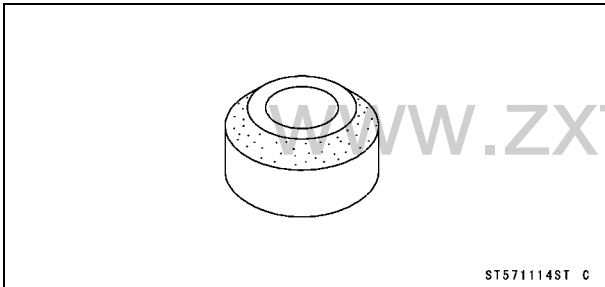

Valve Seat Cutter, 60° - ϕ 25:
57001-1328

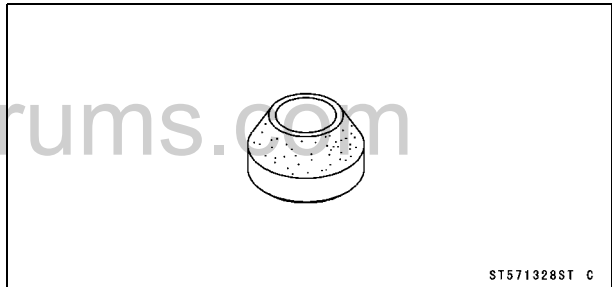

Valve Seat Cutter, 45° - ϕ 35:
57001-1116

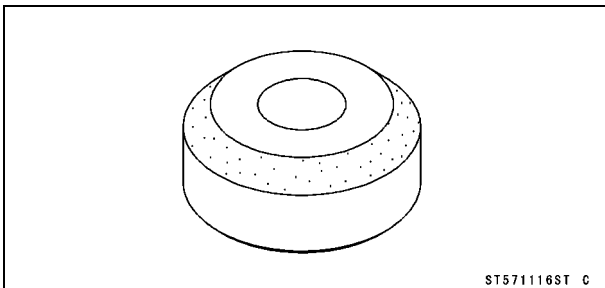

Valve Seat Cutter Holder, ϕ 4.5:
57001-1330

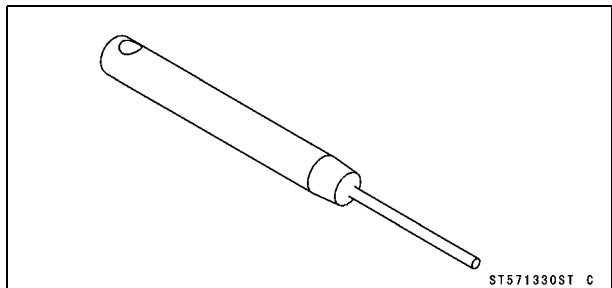

Valve Seat Cutter, 32° - ϕ 28:
57001-1119

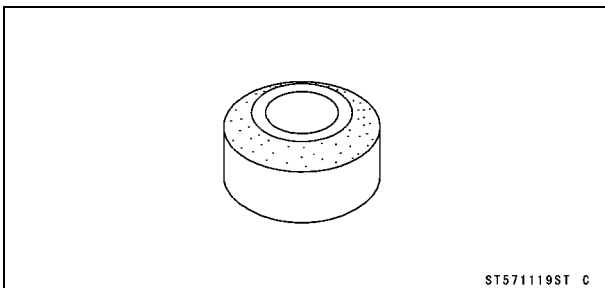

Valve Guide Arbor, ϕ 4.5:
57001-1331

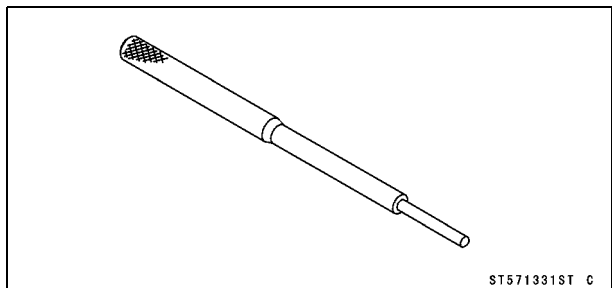

Special Tools and Sealant

Valve Guide Reamer, $\phi 4.5$:
57001-1333

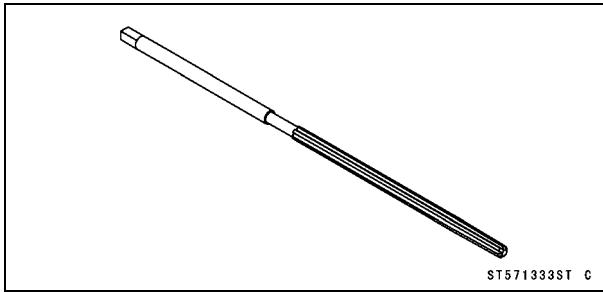

Compression Gauge Adapter, M10 × 1.0:
57001-1601

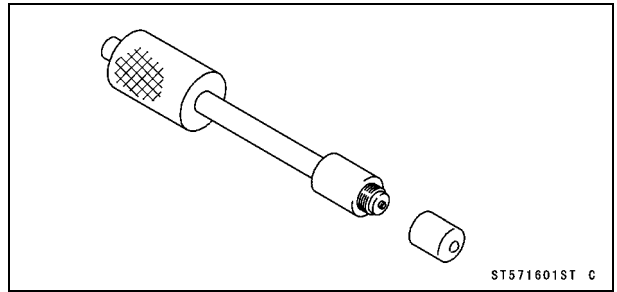

Valve Seat Cutter, 60° - $\phi 33$:
57001-1334

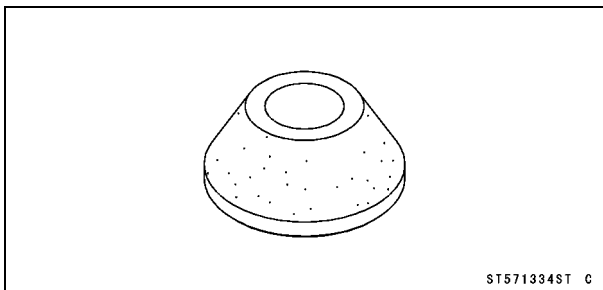

L-Shape Hose:
57001-1606

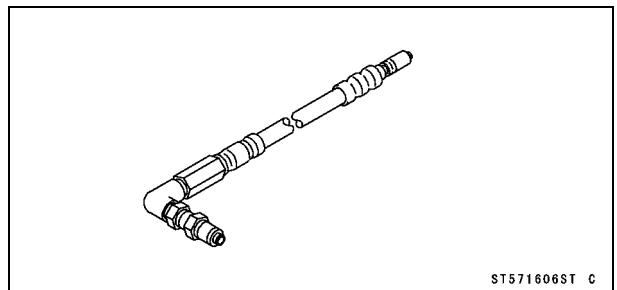

Valve Guide Driver:
57001-1564

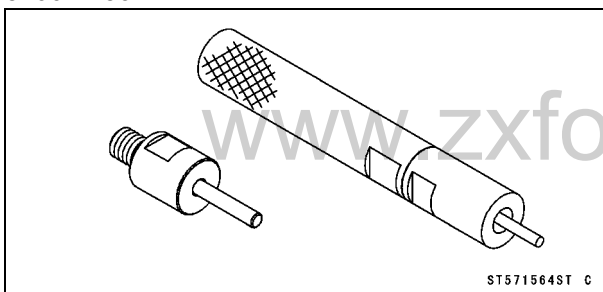

Washer:
57001-1612

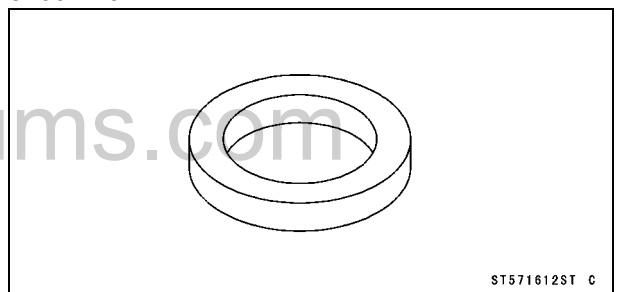

Valve Spring Compressor Adapter, $\phi 24$:
57001-1586

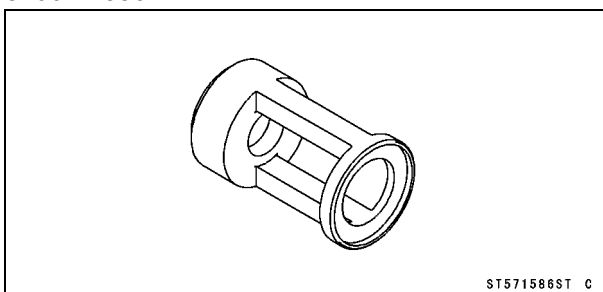

Kawasaki Bond (Silicone Sealant):
92104-0004

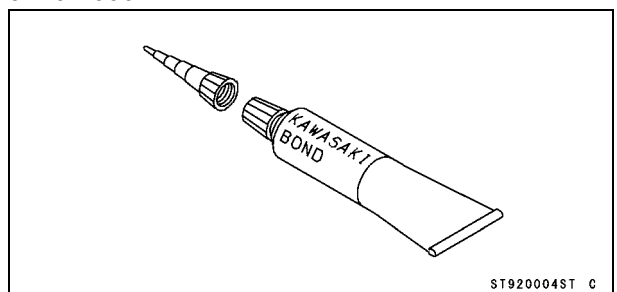

Clean Air System

Air Suction Valve Removal

- Remove:
 - Air Switching Valve (see Air Switching Valve Removal)
 - Air Suction Valve Cover Bolts [A]
 - Air Suction Valve Covers [B]

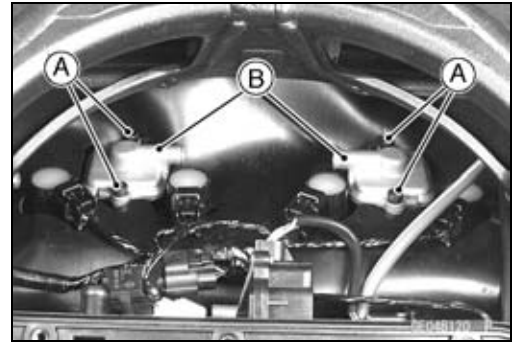

- Remove the air suction valves [A].

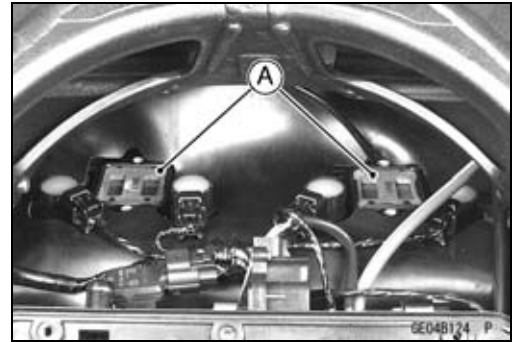

Air Suction Valve Installation

- Install the air suction valve so that opening [A] of the reed faces the rear and downward.
- Apply a non-permanent locking agent to the threads of the air suction valve cover bolts, and tighten them with the specified torque.

Torque - Air Suction Valve Cover Bolts: 10 N·m (1.0 kgf·m, 89 in·lb)

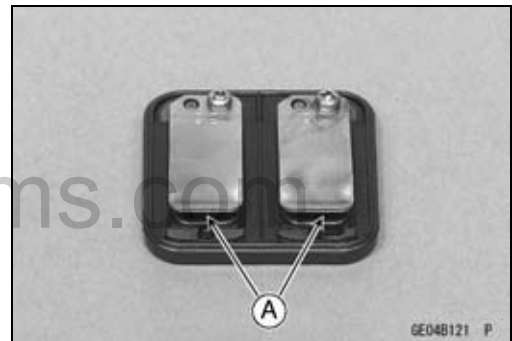

Air Suction Valve Inspection

- Remove the air suction valve (see Air Suction Valve Removal).
- Visually inspect the reeds for cracks, folds, warps, heat damage or other damage.
- ★ If there is any doubt as to the condition of the reeds [A], replace the air suction valve as an assembly.
- Check the reed contact areas [B] of the valve holder for grooves, scratches, any signs of separation from the holder or heat damage.
- If there is any doubt as to the condition of the reed contact areas, replace the air suction valve as an assembly.
- If any carbon or other foreign particles have accumulated between the reed and the reed contact area, wash the valve assembly clean with a high-flash point solvent.

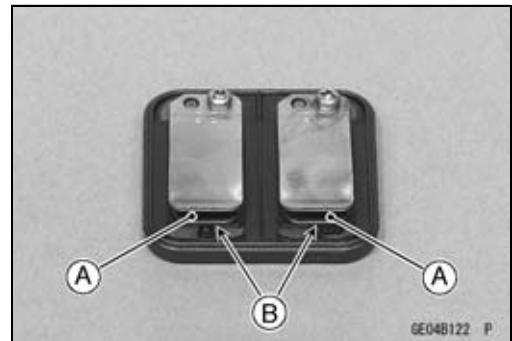

CAUTION

Do not scrape off the deposits with a scraper as this could damage the rubber, requiring replacement of the suction valve assembly.

Clean Air System

Air Switching Valve Removal

- Remove:
 - Fuel Tank (see Fuel Tank Removal in the Fuel System (DFI) chapter)
 - Air Cleaner Housing (see Air Cleaner Housing Removal in the Fuel System (DFI) chapter)
- Disconnect the connector [A].
- Separate the hoses [B] from the air suction valve covers and air cleaner housing holder, and remove the air switching valve [C].

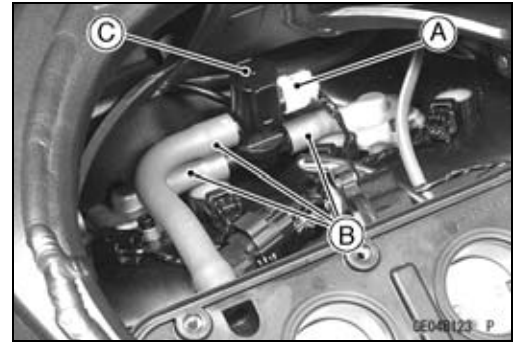

CAUTION

Never drop the air switching valve, especially on a hardsurface. Such a shock to the air switching valve can damaged it.

Air Switching Valve Installation

- Install the air switching valve [A] with hose [B] as shown.
 - White Mark [C]
 - Front [D]
 - Left Side View [E]
- Connect the air switching valve lead connector.

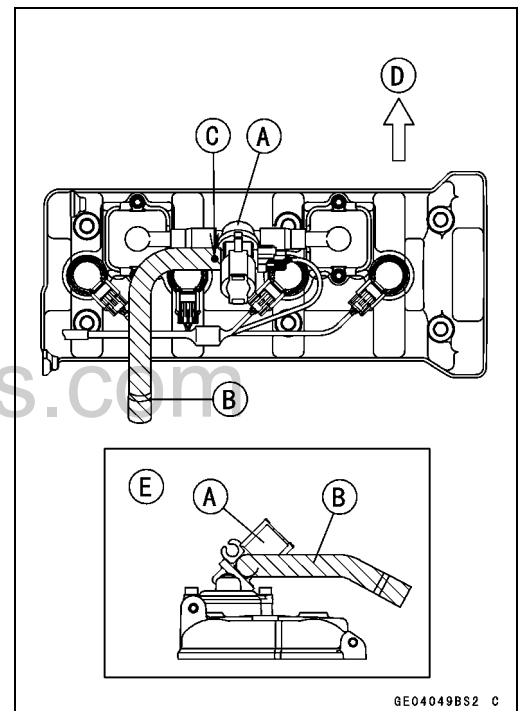

Air Switching Valve Operation Test

- Refer to the Air Suction System Damage Inspection in the Periodic Maintenance chapter (see Air Suction System Damage Inspection in the Periodic Maintenance chapter).

Air Switching Valve Unit Test

- Refer to the Air Switching Valve Unit Test in the Electrical System chapter (see Air Switching Valve Unit Test in the Electrical System chapter).

Clean Air System Hose Inspection

- Be certain that all the hoses are routed without being flattened or kinked, and are connected correctly to the air cleaner housing, air switching valve and air suction valve covers.
- ★ If they are not, correct them. Replace them if they are damaged.

Cylinder Head Cover

Cylinder Head Cover Removal

- Remove:
 - Fuel Tank (see Fuel Tank Removal in the Fuel System (DFI) chapter)
 - Air Cleaner Housing (see Air Cleaner Housing Removal in the Fuel System (DFI) chapter)
 - Air Switching Valve (see Air Switching Valve Removal)
 - Throttle Body Assy (see Throttle Body Assy Removal in the Fuel System (DFI) chapter)
 - Stick Coils (see Stick Coil (Ignition Coil together with Spark Plug Cap) Removal in the Electrical System chapter)
- Remove the radiator [A] temporary (see Radiator and Radiator Fan Removal in the Cooling System chapter), free the heat insulation rubber plate [B].

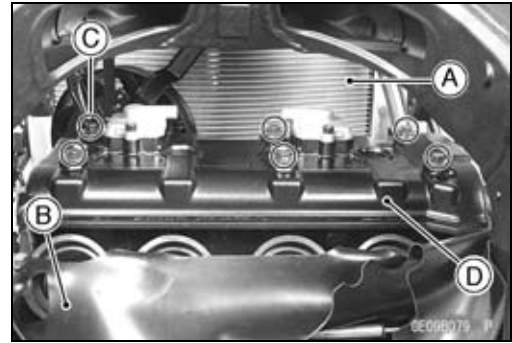

NOTE

○Do not remove radiator hoses.

- Remove the cylinder head cover bolts [C].
- Remove the cylinder head cover [D] to forward.

Cylinder Head Cover Installation

- Replace the head cover gasket [A] with a new one.
- Apply silicone sealant [B] to the cylinder head as shown.

Sealant - Kawasaki Bond (Silicone Sealant): 92104-0004

www.zxforums.com

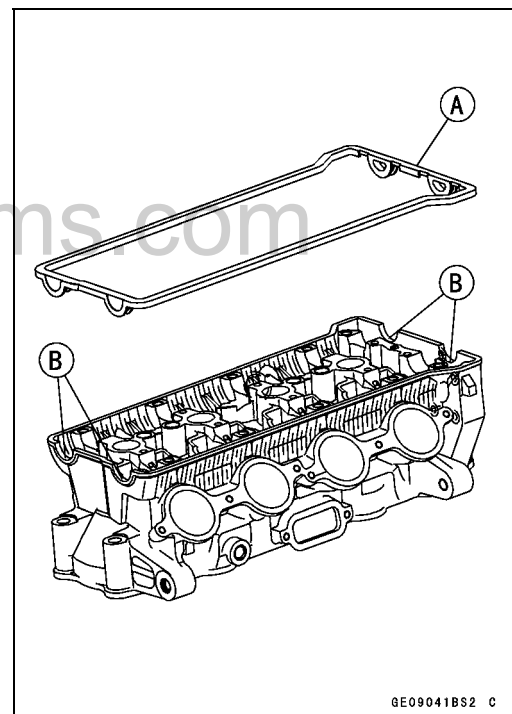

- Be sure to install the following parts.
 - Dowel Pins [A]
 - Plug Hole Gaskets [B]

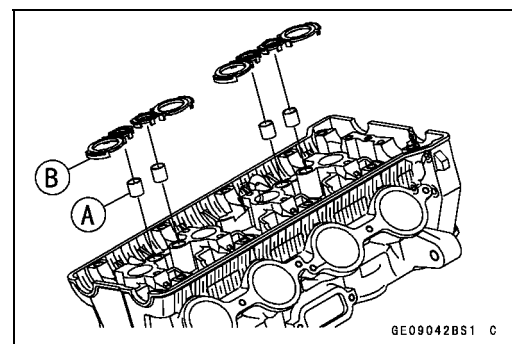

Cylinder Head Cover

- Replace the washer [A] with new ones.
- Install the new washer with the metal side faces upward.

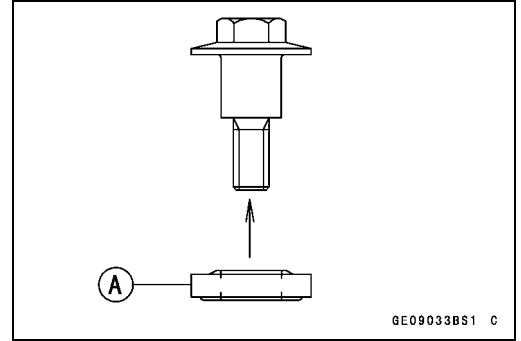

- Install the cylinder head cover.
- Tighten the cover bolts [A].
Torque - Cylinder Head Cover Bolts: 10 N·m (1.0 kgf·m, 89 in·lb)
- Install the removed parts (see appropriate chapters).

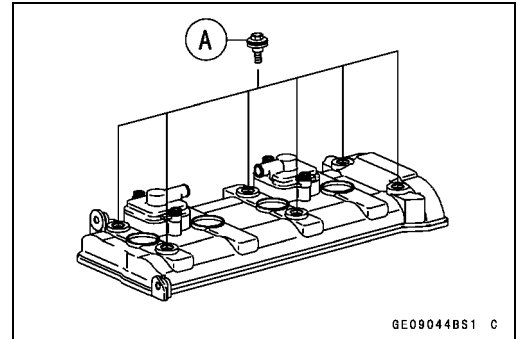

www.zxforums.com

Camshaft Chain Tensioner

Camshaft Chain Tensioner Removal

CAUTION

This is a non-return type camshaft chain tensioner. The push rod does not return to its original position once it moves out to take up camshaft chain slack. Observe all the rules listed below:

When removing the tensioner, do not take out the mounting bolts only halfway. Retightening the mounting bolts from this position could damage the tensioner and the camshaft chain. Once the bolts are loosened, the tensioner must be removed and reset as described in "Camshaft Chain Tensioner Installation."

Do not turn over the crankshaft while the tensioner is removed. This could upset the camshaft chain timing, and damage the valves.

- Drain the coolant (see Coolant Change in the Periodic Maintenance chapter).
- Remove the radiator hose [A] from the radiator pipe [B].
- Put out the radiator hose outside of the clutch cable [C].

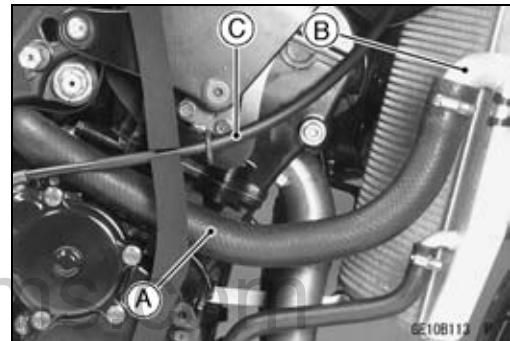

- Remove
Cap Bolt [A]
Washer [B]

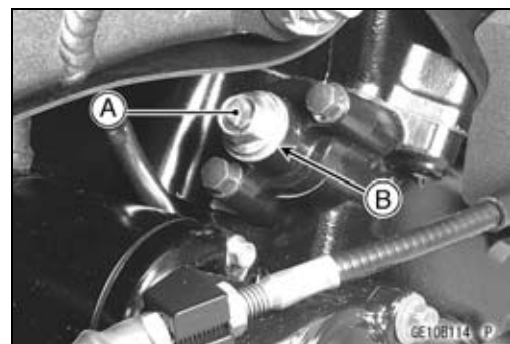

- Remove
Spring [A]
Rod [B]



Camshaft Chain Tensioner

- Remove the mounting bolts [A] and take off the camshaft chain tensioner body [B].

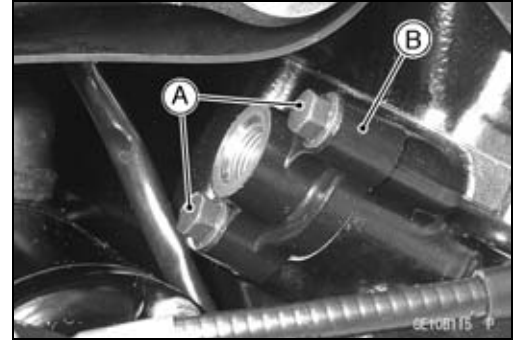

Camshaft Chain Tensioner Installation

- Replace the O-ring [A] with a new one.
- Apply grease to the new O-ring.
- Release the stopper [B] and push the push rod [C] into the interior of tensioner body [D].
- Install the tensioner body so that the stopper faces upward.

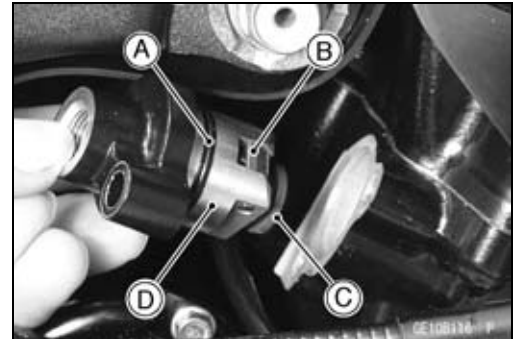

- Tighten the tensioner mounting bolts [A].

Torque - Camshaft Chain Tensioner Mounting Bolts: 10 N·m (1.0 kgf·m, 89 in·lb)

- Install:
 - Rod [B]
 - Spring [C]
 - Washer [D]

- Tighten the cap bolt [E].

Torque - Camshaft Chain Tensioner Cap Bolt: 20 N·m (2.0 kgf·m, 15 ft·lb)

- Run the radiator hose correctly (see Cable, Wire, and hose Routing section in the Appendix chapter).

- Tighten:

Torque - Water Hose Clamp Screw: 2.0 N·m (0.20 kgf·m, 18 in·lb)

- Fill the radiator with coolant (see Coolant Change in the Periodic Maintenance chapter).

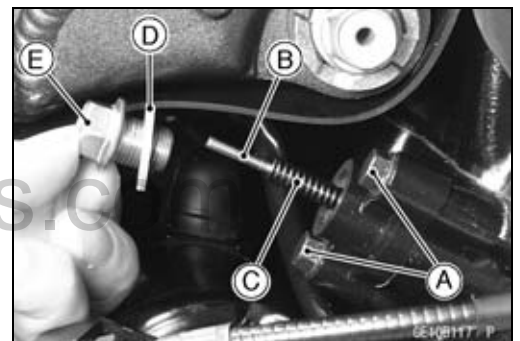

Camshaft, Camshaft Chain

Camshaft Removal

- Remove the cylinder head cover (see Cylinder Head Cover Removal).
- Remove the timing inspection cap [A] and starter clutch bolt cap [B] on the starter clutch cover [C].

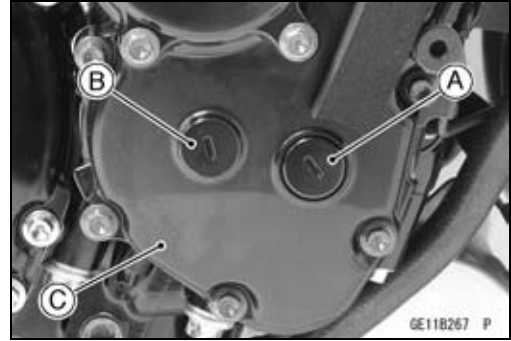

- Using a wrench on the starter clutch bolt [A], turn the crankshaft clockwise until the line [B] (TDC mark for #1,4 pistons) on the starter clutch is aligned with the notch [C] in the edge of the timing inspection hole [D] in the starter clutch cover.

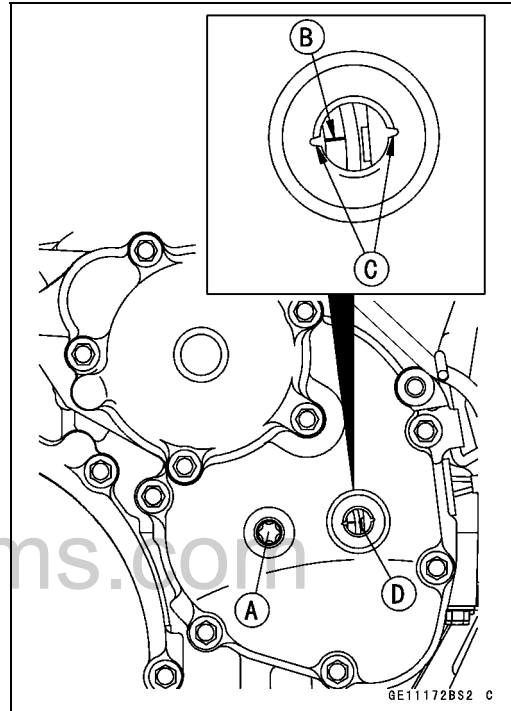

★ If the starter clutch cover is removed, perform the next procedure.

- Using a wrench on the starter clutch bolt [A], turn the crankshaft clockwise until the line [B] (TDC mark for #1,4 pistons) on the starter clutch [C] is aligned with the mating surface [D] of crankcase rear side.

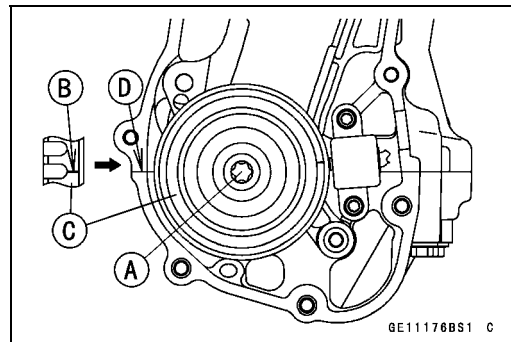

Camshaft, Camshaft Chain

- Remove the camshaft chain tensioner (see Camshaft Chain Tensioner Removal).
- Loosen the upper chain guid bolts and camshaft cap bolts as shown sequence [1 ~ 20] in the figure, and remove them.
- Remove:
 - Upper Chain Guide [A]
 - Camshaft Caps [B]
 - Camshafts [C]
- Stuff a clan cloth into the chain tunnel to keep any parts from dropping into the crankcase.

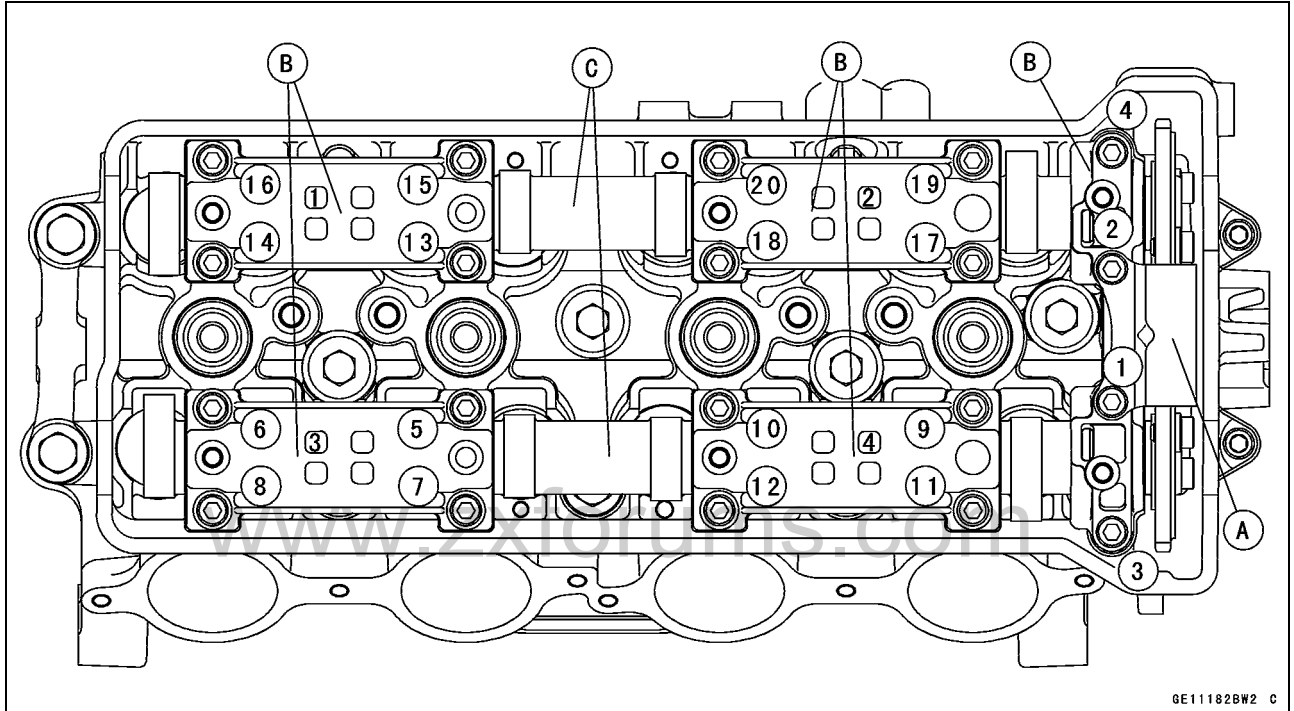

- Remove the cam sprocket mounting bolts [A].
- Remove the cam sprocket.

CAUTION

The crankshaft may be turned while the camshafts are removed. Always pull the chain taut while turning the crankshaft. This avoids kinking the chain on the lower (crankshaft) sprocket. A kinked chain could damage both the chain and the sprocket.

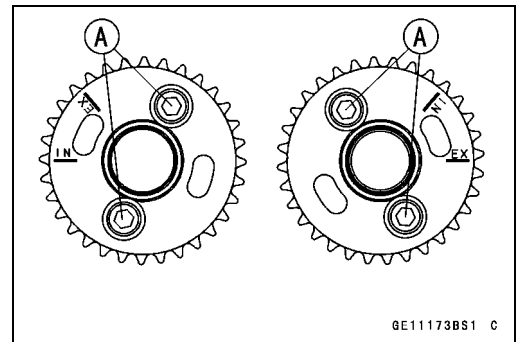

Camshaft Installation

- Be sure to install the following parts.
 - Plug Hole Gaskets [A]
 - Dowel Pins [B]

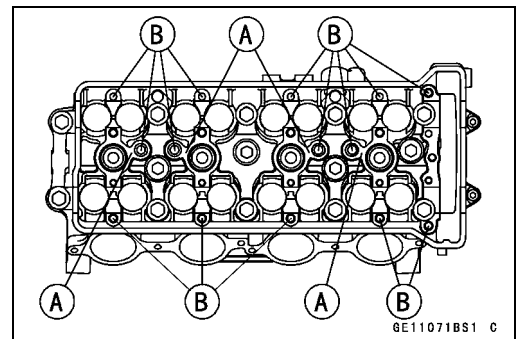

Camshaft, Camshaft Chain

- Install the cam sprockets as shown in figure.
 - #4 Cam Positions [A]
 - Inlet Cam Sprocket [B]
 - Exhaust Cam Sprocket [C]
- Apply a non-permanent locking agent to the threads and tighten the bolts.

Torque - Cam Sprocket Mounting Bolts: 15 N·m (1.5 kgf·m, 11 ft·lb)

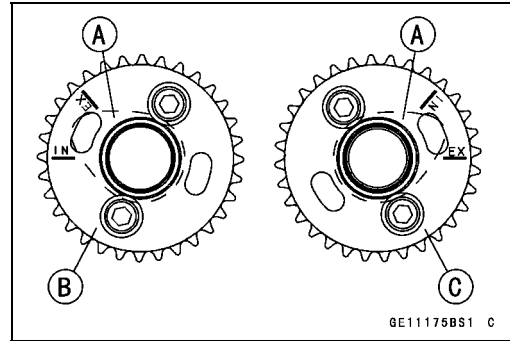

- Apply molybdenum disulfide oil solution to all cam parts and journals.
- ★ If a new camshaft is to be used, apply a thin coat of molybdenum disulfide grease to the cam surfaces.

NOTE

○ The exhaust camshaft has a 1001 EX mark [A] and the inlet camshaft has a 1001 IN mark [B]. Be careful not to mix up these shafts.

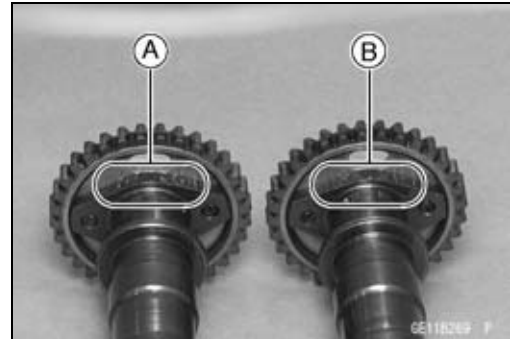

- Using a wrench on the starter clutch bolt [A], turn the crankshaft clockwise until the line [B] (TDC mark for #1,4 pistons) on the starter clutch is aligned with the notch [C] in the edge of the timing inspection hole [D] in the starter clutch cover.

CAUTION

The crankshaft may be turned while the camshafts are removed. Always pull the chain taut while turning the crankshaft. This avoids kinking the chain on the lower (crankshaft) sprocket. A kinked chain could damage both the chain and the sprocket.

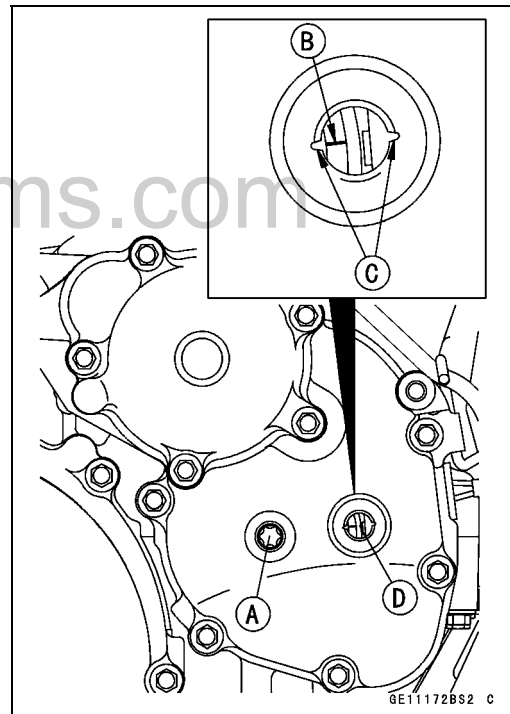

- ★ If the starter clutch cover is removed, perform the next procedure.
- Using a wrench on the starter clutch bolt [A], turn the crankshaft clockwise until the line [B] (TDC mark for #1,4 pistons) on the starter clutch [C] is aligned with the mating surface [D] of crankcase rear side.

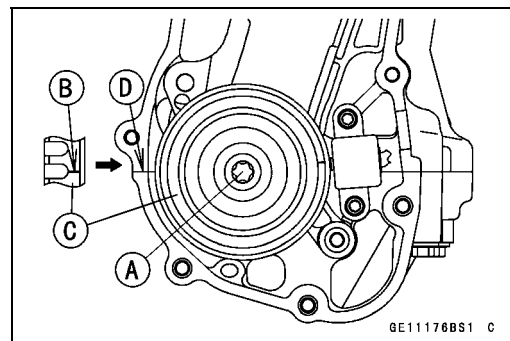

Camshaft, Camshaft Chain

- Pull the tension side (exhaust side) [A] of the chain taut to install the chain.
- Engage the camshaft chain with the sprockets so that timing marks on the sprockets are positioned as shown.
- The Timing marks must be aligned with the cylinder head upper surface [B].
 - EX mark [C]
 - IN mark [D]
 - #1 pin [E]
 - #2 pin [F]
 - #27 pin [G]
 - #28 pin [H]

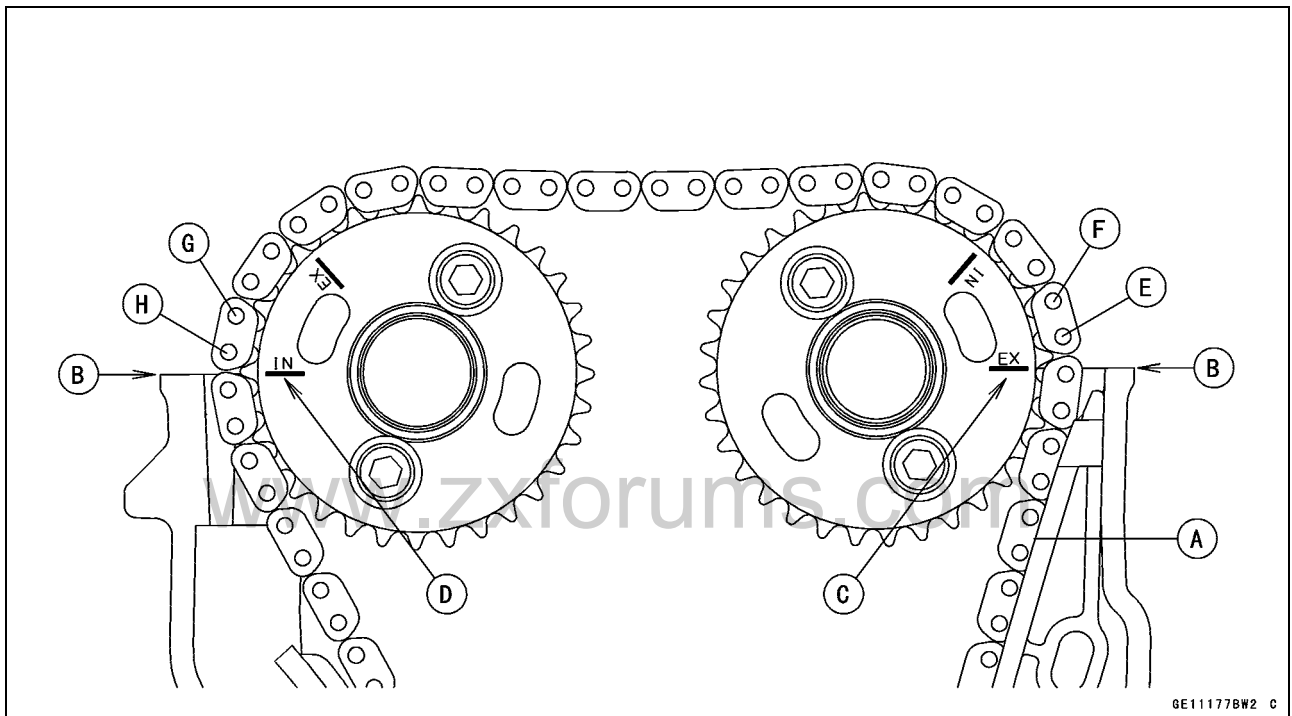

Camshaft, Camshaft Chain

- Before installing the camshaft caps and upper chain guide, install the camshaft chain tensioner body temporarily (see Camshaft Chain Tensioner Installation).
- Install the camshaft caps and upper camshaft chain guide [A] as shown.
Identification Number 1 ~ 4 (Camshaft Cap Side) [B]
Identification Number 1 ~ 4 (Cylinder Head Side) [C]
- First tighten the camshaft cap bolt (17, 18) and upper chain guide bolts (19, 20) evenly to seat the camshaft in place, then tighten all bolts following the specified tightening sequence.

Torque - Camshaft Cap Bolts (1 ~ 18): 12 N·m (1.2 kgf·m, 106 in·lb)

Upper Camshaft Chain Guide Bolts (19, 20): 12 N·m (1.2 kgf·m, 106 in·lb)

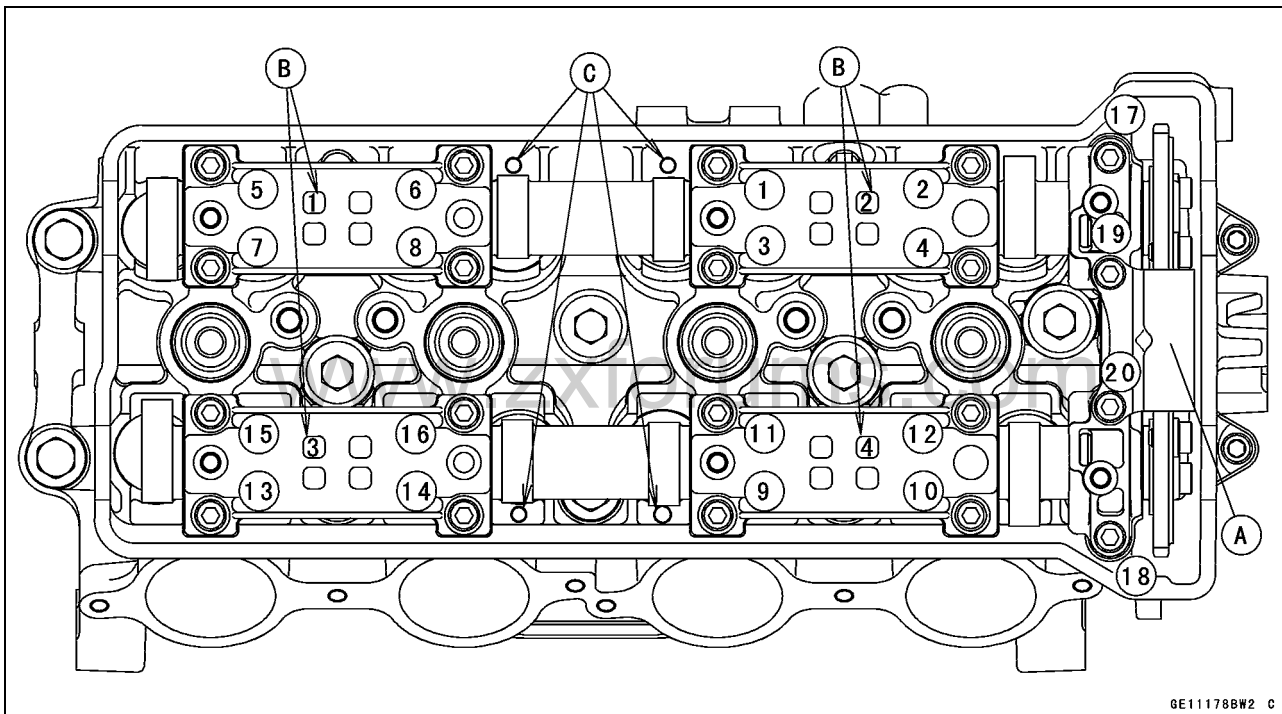

GE11178BW2 C

- Install the camshaft chain tensioner (see Camshaft Chain Tensioner Installation).
- Turn the crankshaft 2 turns clockwise to allow the tensioner to expand and recheck the camshaft chain timing.
- Replace the O-ring of the timing inspection cap and starter clutch bolt cap with new ones.
- Apply grease to the new O-rings.
- Install the timing inspection cap and starter clutch bolt cap.

Torque - Timing Inspection Cap: Hand-tighten

Starter Clutch Bolt Cap: Hand-tighten

- Install the cylinder head cover (see Cylinder Head Cover Installation).

Camshaft, Camshaft Chain

Camshaft, Camshaft Cap Wear

- Remove the camshaft cap (see Camshaft Removal).
- Cut strips of plastigage to journal width. Place a strip on each journal parallel to the camshaft installed in the correct position.
- Tighten the camshaft cap bolts and upper chain guide bolts to the specified torque (see Camshaft Installation).

NOTE

○ Do not turn the camshaft when the plastigage is between the journal and camshaft cap.

- Remove the camshaft cap again, measure each clearance between the camshaft journal and the camshaft cap using plastigage (press gauge) [A].

Camshaft Journal, Camshaft Cap Clearance

Standard: 0.038 ~ 0.081 mm (0.0015 ~ 0.0032 in.)

Service Limit: 0.17 mm (0.0067 in.)

- ★ If any clearance exceeds the service limit, measure the diameter of each camshaft journal with a micrometer.

Camshaft Journal Diameter

Standard: 23.940 ~ 23.962 mm (0.9425 ~ 0.9434 in.)

Service Limit: 23.91 mm (0.941 in.)

- ★ If the camshaft journal diameter is less than the service limit, replace the camshaft with a new one and measure the clearance again.
- ★ If the clearance still remains out of the limit, replace the cylinder head unit.

Camshaft Runout

- Remove the camshaft (see Camshaft Removal).
- Set the camshaft in a camshaft alignment jig or on V blocks.
- Measure runout with a dial gauge at the specified place as shown.
- ★ If the runout exceeds the service limit, replace the shaft.

Camshaft Runout

Standard: TIR 0.02 mm (0.0008 in.) or less

Service Limit: TIR 0.1 mm (0.004 in.)

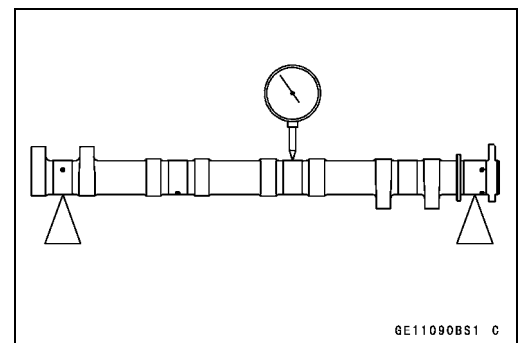
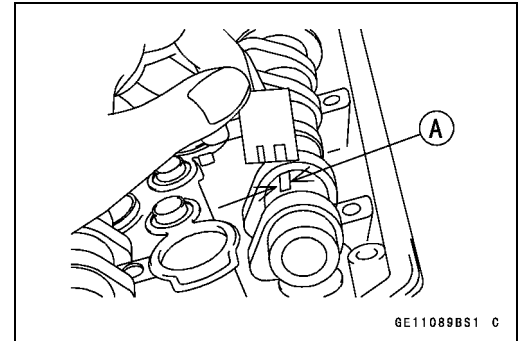

Camshaft, Camshaft Chain

Cam Wear

- Remove the camshaft (see Camshaft Removal).
- Measure the height [A] of each cam with a micrometer.
- ★ If the cams are worn down past the service limit, replace the camshaft.

Cam Height

Standard:

Exhaust 34.443 ~ 34.557 mm (1.3560 ~ 1.3605 in.)

Inlet 35.043 ~ 35.157 mm (1.3796 ~ 1.3841 in.)

Service Limit:

Exhaust 34.34 mm (1.352 in.)

Inlet 35.94 mm (1.376 in.)

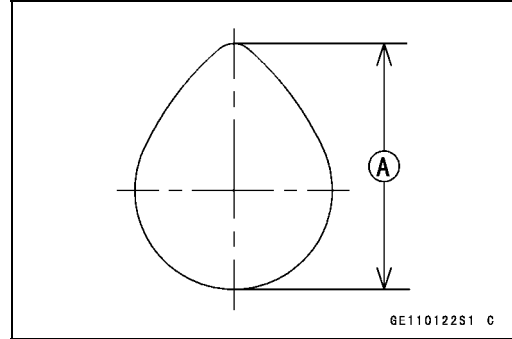

Camshaft Chain Removal

- Split the crankcase (see Crankcase Splitting in the Crankshaft/Transmission chapter).
- Remove the camshaft chain [A] from the crankshaft sprocket.

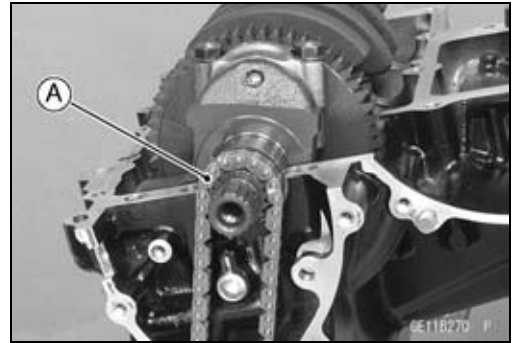

www.zxforums.com

Cylinder Head

Cylinder Compression Measurement

NOTE

- Use the battery which is fully charged.
- Warm up the engine thoroughly.
- Stop the engine.
- Remove:
 - Fuel Tank (see Fuel Tank Removal in the Fuel System (DFI) chapter)
 - Air Cleaner Housing (Air Cleaner Housing Removal in the Fuel System (DFI) chapter)
 - Stick Coils (see Stick Coil (Ignition Coil together with Spark Plug Cap Removal in the Electrical System chapter)
 - Spark Plugs (see Spark Plug Replacement in the Periodic Maintenance chapter)
- Attach the compression gauge [A] and adapter [B] firmly into the spark plug hole.
- Using the starter motor, turn the engine over with the throttle fully open until the compression gauge stops rising; the compression is the highest reading obtainable.

Special Tools - Compression Gauge, 20 kgf/cm²: 57001-221
Compression Gauge Adapter, M10 × 1.0: 57001-1601
L-Shape Hose: 57001-1606

Cylinder Compression

Usable Range: 1 100 ~ 1 670 kPa (11.2 ~ 17.0 kgf/cm², 159 ~ 242 psi) at 20 r/min (rpm)

- Repeat the measurement for the other cylinders.
- Install the spark plugs.

Torque - Spark Plugs: 13 N·m (1.3 kgf·m, 115 in·lb)

The following table should be consulted if the obtainable compression reading is not within the usable range.

Problem	Diagnosis	Remedy (Action)
Cylinder compression is higher than usable range	Carbon accumulation on piston and in combustion chamber possibly due to damaged valve stem oil seal and/or damaged piston oil rings (This may be indicated by white exhaust smoke).	Remove the carbon deposits and replace damaged parts if necessary.
	Incorrect cylinder head gasket thickness	Replace the gasket with a standard part.
Cylinder compression is lower than usable range	Gas leakage around cylinder head	Replace damaged check gasket and cylinder head warp.
	Bad condition of valve seating	Repair if necessary.
	Incorrect valve clearance	Adjust the valve clearance.
	Incorrect piston/cylinder clearance	Replace the piston and/or cylinder.
	Piston seizure	Inspect the cylinder and replace/repair the cylinder and/or piston as necessary.
	Bad condition of piston ring and/or piston ring grooves	Replace the piston and/or the piston rings.

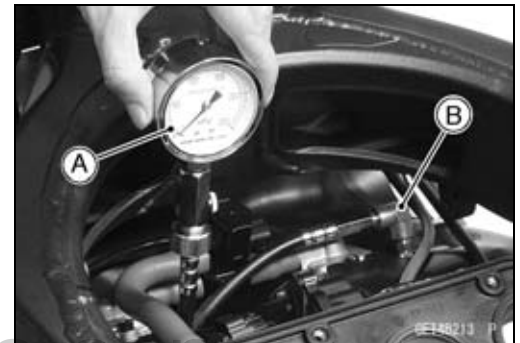

Cylinder Head

Cylinder Head Removal

- Drain the coolant (see Coolant Change in the Periodic Maintenance chapter).
- Remove:
 - Fuel Tank (see Fuel Tank Removal in the Fuel System (DFI) chapter)
 - Air Cleaner Housing (Air Cleaner Housing Removal in the Fuel System (DFI) chapter)
 - Throttle Body Assy (see Throttle Body Assy Removal in the Fuel System (DFI) chapter)
 - Water Temperature Sensor Lead Connector (see Removal/Installation in the Fuel System (DFI) chapter)
 - Clutch Cable Lower End (see Cable Removal in the Clutch chapter)
 - Front Exhaust Pipe (see Front Exhaust Pipe Removal)
 - Cylinder Head Cover (see Cylinder Head Cover Removal)
 - Camshafts (see Camshaft Removal)
- Remove the front camshaft chain guide bolt (upper) [A].



www.zxforums.com

- Remove:
 - Crankshaft Sensor (see Crankshaft Sensor Removal in the Electrical System chapter)
 - Starter Clutch (see Starter Clutch Removal in the Electrical System chapter)
 - Left and Right Front Engine Mounting Bolts (see Engine Removal in the Engine Removal/Installation chapter)
 - Front Camshaft Chain Guide Bolt (Lower) [A]
 - Front Camshaft Chain Guide [B]

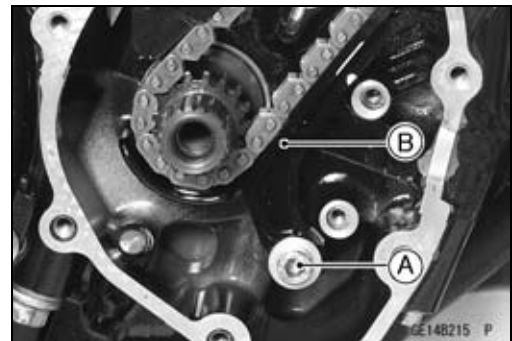

- Loosen the M6 and M10 cylinder head bolts as shown sequence [1 ~ 10] in the figure, and remove them.
- Take off the cylinder head to forward.

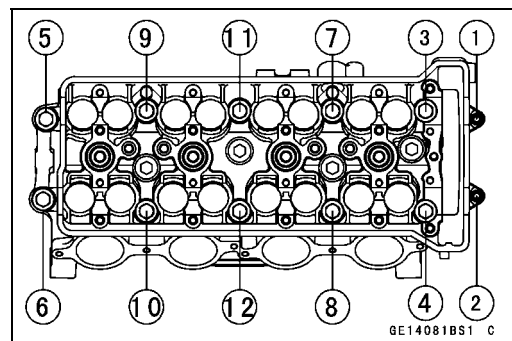

Cylinder Head

Cylinder Head Installation

NOTE

○The camshaft cap is machined with the cylinder head, so if a new cylinder head is installed, use the cap that is supplied with the new head.

- Install the dowel pins.
- Replace the cylinder head gasket with a new one.
- Apply molybdenum disulfide oil solution to both sides [A] of the cylinder head bolt washers [B] and the threads of the head bolts [C].
- Install the left engine bracket (cylinder head side) [A] so that the boss side [B] faces outward. Front [C]

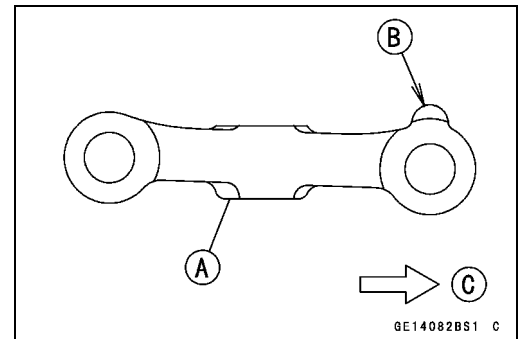
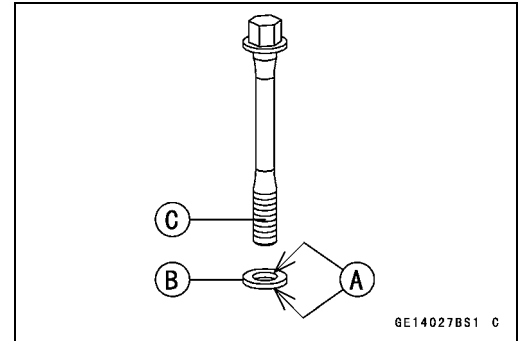

- Tighten the M10 cylinder head bolts following the tightening sequence [1 ~ 10].

Torque - Cylinder Head Bolts (M10):

First: 20 N·m (2.0 kgf·m, 15 ft·lb)

Final (New Bolts): 59 N·m (6.0 kgf·m, 44 ft·lb)

Final (Used Bolts): 57 N·m (5.8 kgf·m, 42 ft·lb)

- Tighten the M6 cylinder head bolts [11 ~ 12].
- Torque - Cylinder Head Bolts (M6): 12 N·m (1.2 kgf·m, 106 in·lb)

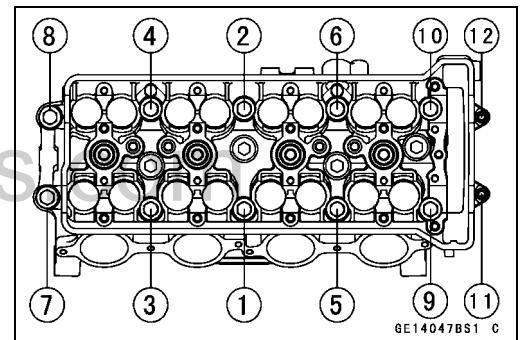

- Install:
 - Left and Right Front Engine Mounting Bolts (see Engine Removal in the Engine Removal/Installation chapter)
 - Front Camshaft Chain Guide [A]
 - New O-ring [B]
 - Collar [C]
- Apply grease to the new O-ring.
- Tighten:
 - Torque - Front Camshaft Chain Guide Bolt (Upper) [D]: 25 N·m (2.5 kgf·m, 18 ft·lb)
 - Front Camshaft Chain Guide Bolt (Lower) [E]: 1.2 N·m (2.5 kgf·m, 106 in·lb)
- Install the removed parts (see appropriate chapters).

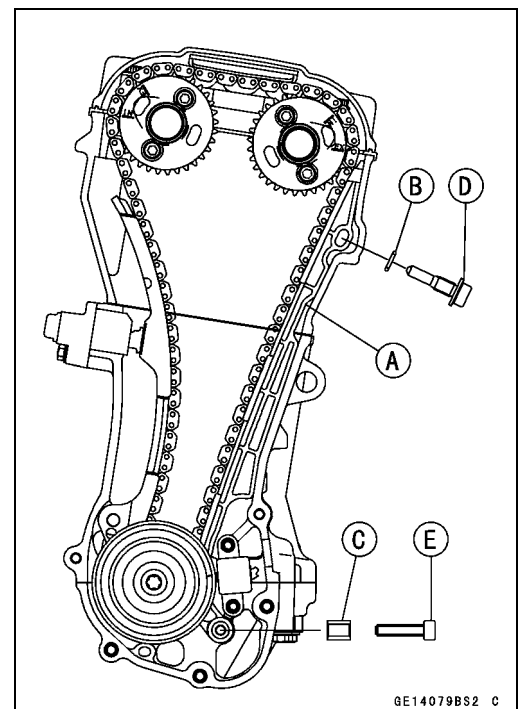

Cylinder Head

Cylinder Head Warp

- Clean the cylinder head.
- Lay a straightedge across the lower surface of the cylinder head at several positions.
- Use a thickness gauge [A] to measure the space between the straightedge [B] and the head.

Cylinder Head Warp

Standard: - - -

Service Limit: 0.05 mm (0.002 in.)

- ★ If the cylinder head is warped more than the service limit, replace it.
- ★ If the cylinder head is warped less than the service limit, repair the head by rubbing the lower surface on emery paper secured to a surface plate (first No. 200, then No. 400).

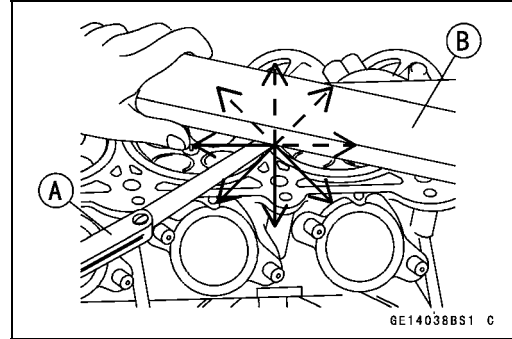

www.zxforums.com

Valves

Valve Clearance Inspection

- Refer to the Valve Clearance Inspection in the Periodic Maintenance chapter (see Valve Clearance Inspection in the Periodic Maintenance chapter).

Valve Removal

- Remove the cylinder head (see Cylinder Head Removal).
- Remove the valve lifter and shim.
- Mark and record the valve lifter and shim locations so they can be installed in their original positions.
- Using the valve spring compressor assembly, remove the valve.

Special Tools - Valve Spring Compressor Assembly [A]:
57001-241

Adapter, ϕ 24 [B]: 57001-1586

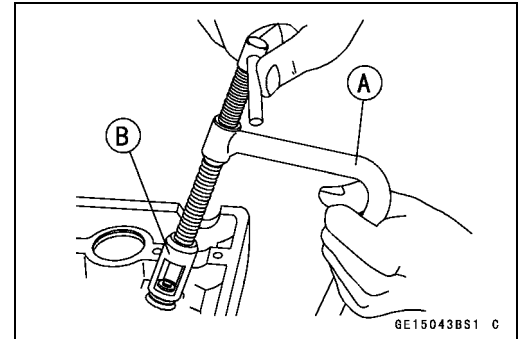

Valve Installation

CAUTION

Do not lap the exhaust valve to the exhaust valve seat, using the grinding compound. It will come off oxide film treated surface of the valve.

- Replace the oil seal with a new one.
 - Apply a thin coat of molybdenum disulfide grease to the valve stem before valve installation.
 - Install the springs so that the closed coil end faces downwards.
- Valve Stem [A]
Oil Seal [B]
Spring Seat [C]
Closed Coil End [D]
Valve Spring [E]:
EX-Purple Paint
IN-Green Paint
Retainer [F]
Split Keepers [G]

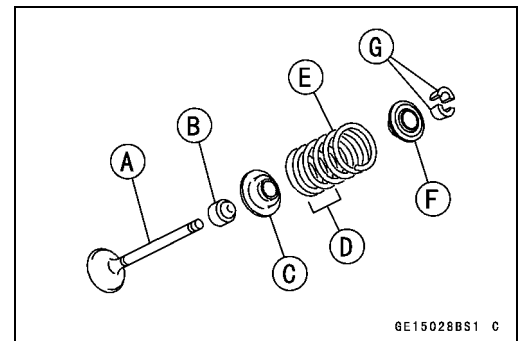

Valve Guide Removal

- Remove:
 - Valve (see Valve Removal)
 - Oil Seal
 - Spring Seat
- Heat the area around the valve guide to 120 ~ 150°C (248 ~ 302°F), and hammer lightly on the valve guide arbor [A] to remove the guide from the top of the head.

CAUTION

Do not heat the cylinder head with a torch. This will warp the cylinder head. Soak the cylinder head in oil and heat the oil.

Special Tool - Valve Guide Arbor, ϕ 4.5: 57001-1331

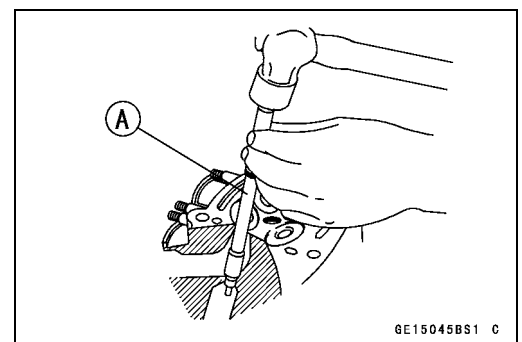

Valves

Valve Guide Installation

- Apply oil to the valve guide outer surface before installation.
- Heat the area around the valve guide hole to about 120 ~ 150°C (248 ~ 302°F).

CAUTION

Do not heat the cylinder head with a torch. This Will warp the cylinder head. Soak the cylinder head and heat the oil.

- Using the valve guide driver [A] and washer [B], press and insert the valve guide in until the valve guide driver surface [C] touches the head surface [D].

13.3 ~ 13.5 mm (0.52 ~ 0.53 in.) [E]

Special Tools - Valve Guide Driver: 57001-1564

Washer: 57001-1612

- Ream the valve guide with valve guide reamer [A], even if the old guide is reused.

Special Tool - Valve Guide Reamer, $\phi 4.5$: 57001-1333

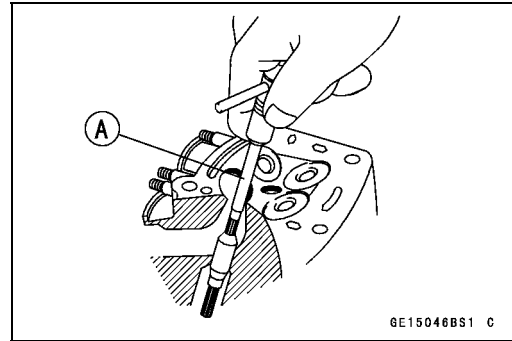

6E15046BS1 C

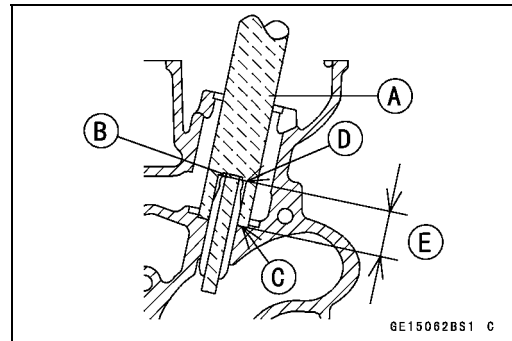

6E15082BS1 C

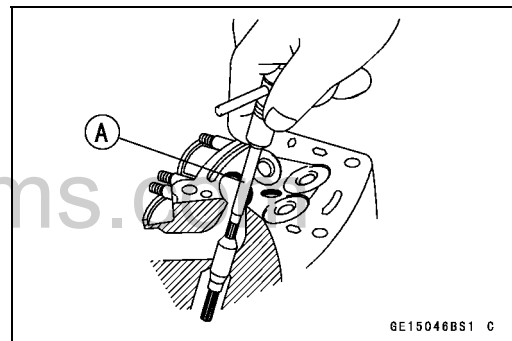

6E15046BS1 C

Valve-to-Guide Clearance Measurement (Wobble Method)

If a small bore gauge is not available, inspect the valve guide wear by measuring the valve to valve guide clearance with the wobble method as indicated below.

- Insert a new valve [A] into the guide [B] and set a dial gauge against the stem perpendicular to it as close as possible to the cylinder head mating surface.
- Move the stem back and forth [C] to measure valve/valve guide clearance.
- Repeat the measurement in a direction at a right angle to the first.

★ If the reading exceeds the service limit, replace the guide.

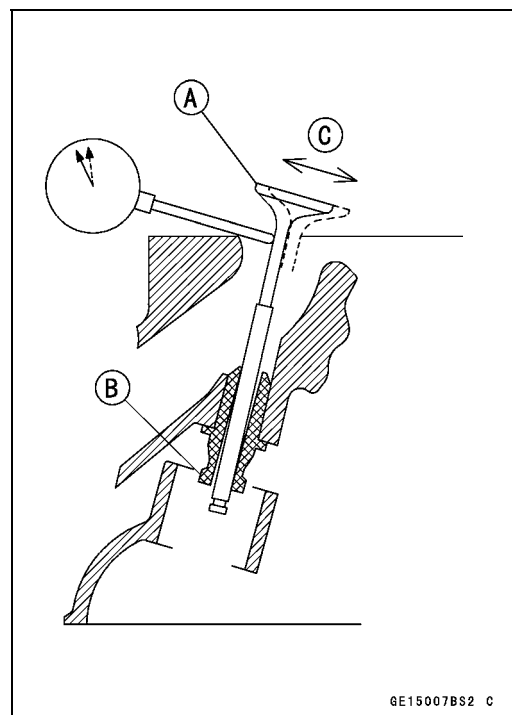

6E15007BS2 C

Valves

NOTE

- The reading is not actual valve/valve guide clearance because the measuring point is above the guide.

Valve/Valve Guide Clearance (Wobble Method)

Standard:

Exhaust	0.04 ~ 0.12 mm (0.0016 ~ 0.0047 in.)
Inlet	0.03 ~ 0.10 mm (0.0012 ~ 0.0039 in.)

Service Limit:

Exhaust	0.34 mm (0.013 in.)
Inlet	0.34 mm (0.013 in.)

Valve Seat Inspection

- Remove the valve (see Valve Removal).
 - Check the valve seating surface [A] between the valve [B] and valve seat [C].
- Measure the outside diameter [D] of the seating pattern on the valve seat.
- ★ If the outside diameter is too large or too small, repair the seat (see Seat Repair).

Valve Seating Surface Outside Diameter

Standard:

Exhaust	24.9 ~ 25.1 mm (0.980 ~ 0.988 in.)
Inlet	29.4 ~ 29.6 mm (1.157 ~ 1.165 in.)

- Measure the seat width [E] of the portion where there is no build-up carbon (white portion) of the valve seat with a vernier caliper.

Good [F]

- ★ If the width is too wide [G], too narrow [H] or uneven [J], repair the seat (see Valve Seat Repair).

Valve Seating Surface Width

Standard:

Exhaust	0.8 ~ 1.2 mm (0.031 ~ 0.047 in.)
Inlet	0.5 ~ 1.0 mm (0.020 ~ 0.039 in.)

Valve Seat Repair

- Repair the valve seat with the valve seat cutters [A].

Special Tools - Valve Seat Cutter Holder Bar: 57001-1128 [C]

Valve Seat Cutter Holder, $\phi 4.5$: 57001-1330 [B]

For Exhaust Valve Seat

Valve Seat Cutter, 45° - $\phi 27.5$: 57001-1114
Valve Seat Cutter, 32° - $\phi 28$: 57001-1119
Valve Seat Cutter, 60° - $\phi 25$: 57001-1328

For Inlet Valve Seat

Valve Seat Cutter, 45° - $\phi 35$: 57001-1116
Valve Seat Cutter, 32° - $\phi 35$: 57001-1121
Valve Seat Cutter, 60° - $\phi 33$: 57001-1334

- ★ If the manufacturer's instructions are not available, use the following procedure.

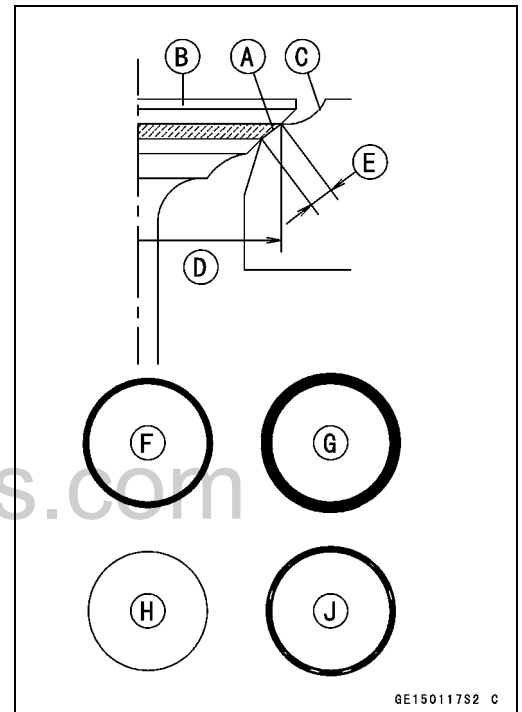

6E150117S2 C

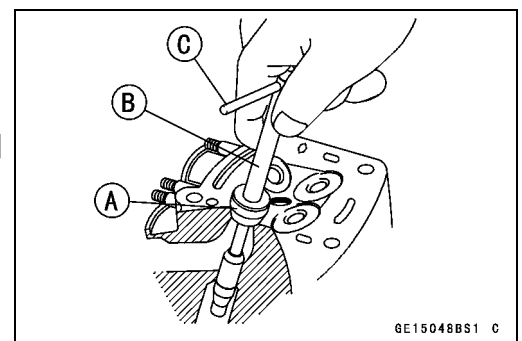

6E15048BS1 C

Valves

Seat Cutter Operation Care

1. This valve seat cutter is developed to grind the valve for repair. Therefore the cutter must not be used for other purposes than seat repair.
2. Do not drop or shock the valve seat cutter, or the diamond particles may fall off.
3. Do not fail to apply engine oil to the valve seat cutter before grinding the seat surface. Also wash off ground particles sticking to the cutter with washing oil.

NOTE

○Do not use a wire brush to remove the metal particles from the cutter. It will take off the diamond particles.

4. Setting the valve seat cutter holder in position, operate the cutter in one hand. Do not apply too much force to the diamond portion.

NOTE

○Prior to grinding, apply engine oil to the cutter and during the operation, wash off any ground particles sticking to the cutter with washing oil.

5. After use, wash it with washing oil and apply thin layer of engine oil before storing.

Marks Stamped on the Cutter

The marks stamped on the back of the cutter [A] represent the following.

- 60° Cutter angle [B]
- φ37.5 Outer diameter of cutter [C]

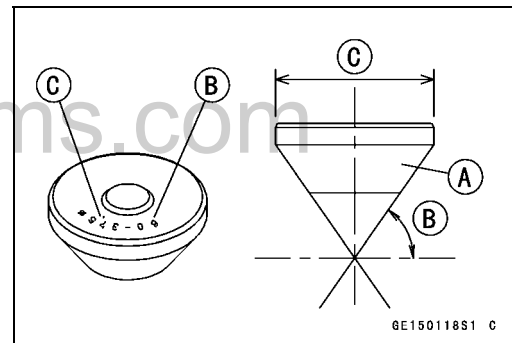

Operating Procedures

- Clean the seat area carefully.
- Coat the seat with machinist's dye.
- Fit a 45° cutter into the holder and slide it into the valve guide.
- Press down lightly on the handle and turn it right or left. Grind the seating surface only until it is smooth.

CAUTION

Do not grind the seat too much. Overgrinding will reduce valve clearance by sinking the valve into the head. If the valve sinks too far into the head, it will be impossible to adjust the clearance, and the cylinder head must be replaced.

Valves

- Measure the outside diameter of the seating surface with a vernier caliper.
- ★ If the outside diameter of the seating surface is too small, repeat the 45° grind until the diameter is within the specified range.
 - Widened Width [A] of engagement by machining with 45° cutter
 - Ground Volume [B] by 32° cutter
 - 32° [C]
 - Correct Width [D]
 - Ground Volume [E] by 60° cutter
 - 60° [F]

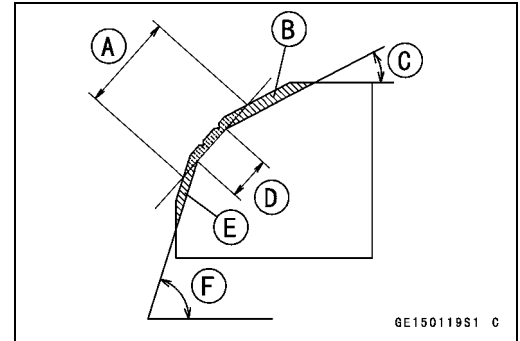

- Measure the outside diameter of the seating surface with a vernier caliper.
- ★ If the outside diameter of the seating surface is too small, repeat the 45° grind [A] until the diameter is within the specified range.
 - Original Seating Surface [B]

NOTE

- Remove all pittings of flaws from 45° ground surface.
- After grinding with 45° cutter, apply thin coat of machinist's dye to seating surface. This makes seating surface distinct and 32° and 60° grinding operation easier.
- When the valve guide is replaced, be sure to grind with 45° cutter for centering and good contact.

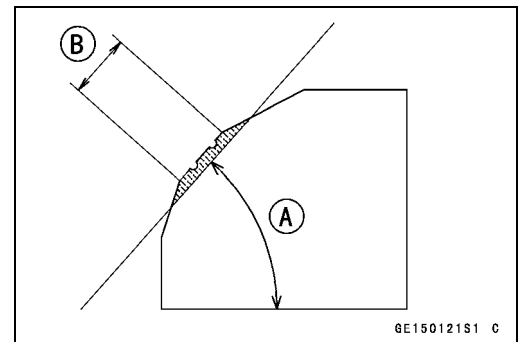

- ★ If the outside diameter [A] of the seating surface is too large, make the 32° grind described below.
- ★ If the outside diameter of the seating surface is within the specified range, measure the seat width as described below.
- Grind the seat at a 32° angle [B] until the seat O.D. is within the specified range.
 - To make the 32° grind, fit a 32° cutter into the holder, and slide it into the valve guide.
 - Turn the holder one turn at a time while pressing down very lightly. Check the seat after each turn.

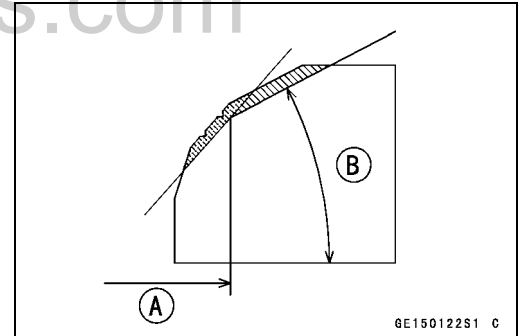

CAUTION

The 32° cutter removes material very quickly. Check the seat outside diameter frequently to prevent overgrinding.

- After making the 32° grind, return to the seat O.D. measurement step above.
- To measure the seat width, use a vernier caliper to measure the width of the 45° angle portion of the seat at several places around the seat.
- ★ If the seat width is too narrow, repeat the 45° grind until the seat is slightly too wide, and then return to the seat O.D. measurement step above.

Valves

- ★ If the seat width is too wide, make the 60° [A] grind described below.
 - ★ If the seat width is within the specified range, lap the valve to the seat as described below.
 - Grind the seat at a 60° angle until the seat width is within the specified range.
 - To make the 60° grind, fit 60° cutter into the holder, and slide it into the valve guide.
 - Turn the holder, while pressing down lightly.
 - After making the 60° grind, return to the seat width measurement step above.
- Correct Width [B]

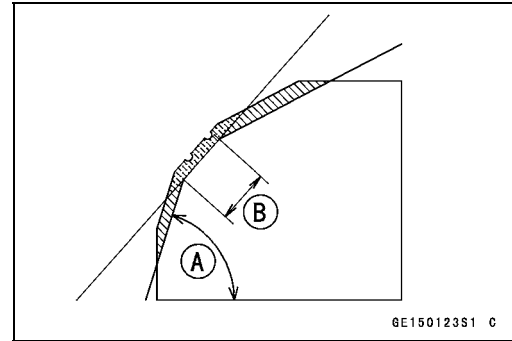

CAUTION

Do not lap the exhaust valve to the exhaust valve seat, using the grinding compound. It will come off oxide film treated surface of the valve.

- Lap the inlet valve to the inlet valve seat, once the seat width and O.D. are within the ranges specified above.
 - Put a little coarse grinding compound on the face of the valve in a number of places around the valve head.
 - Spin the valve against the seat until the grinding compound produces a smooth, matched surface on both the seat and the valve.
 - Repeat the process with a fine grinding compound.
- Lapper [A]
 Valve Seat [B]
 Valve [C]
- The seating area should be marked about in the middle of the valve face.
 - ★ If the seat area is not in the right place on the valve, check to be sure the valve is the correct part. If it is, it may have been refaced too much; replace it.
 - Be sure to remove all grinding compound before assembly.
 - When the engine is assembled, be sure to adjust the valve clearance (see Valve Clearance Inspection in the Periodic Maintenance chapter).

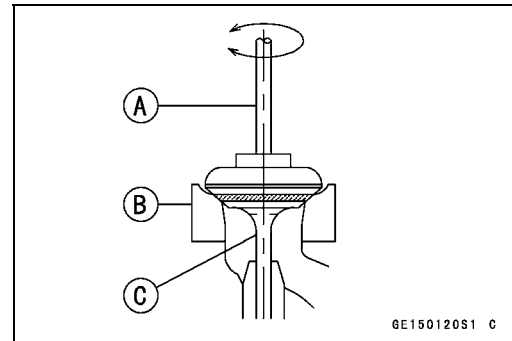

Valves

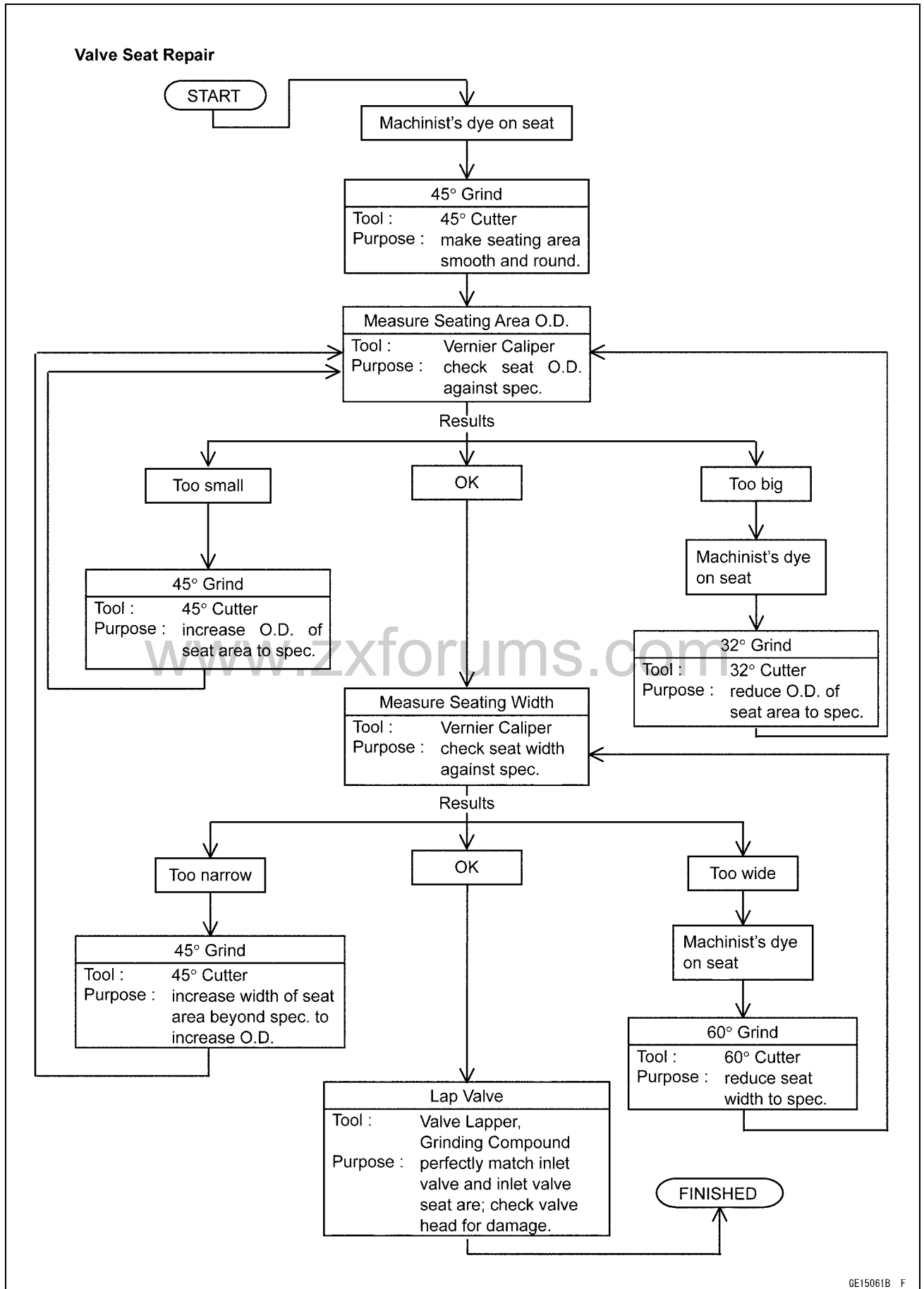

GE15061B F

Throttle Body Assy Holder

Throttle Body Assy Holder Removal

- Remove:
 - Fuel Tank (see Fuel Tank Removal in the Fuel System (DFI) chapter)
 - Air Cleaner Housing (Air Cleaner Housing Removal in the Fuel System (DFI) chapter)
 - Throttle Body Assy (Throttle Body Assy Removal in the Fuel System (DFI) chapter)
 - Clamps [A]
- Loosen the throttle body assy holder bolts as shown sequence [1 ~ 3] in the figure, and remove them.
- Remove the throttle body assy holders [B].

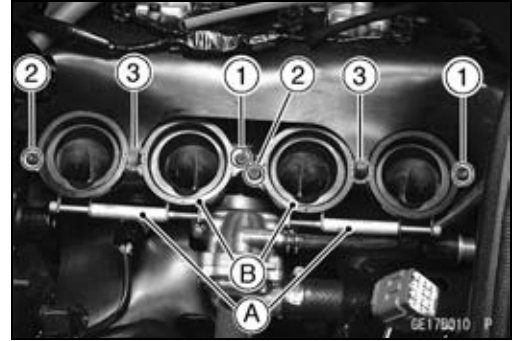

Throttle Body Assy Holder Installation

- Be sure to install the new O-rings [A].
- Apply grease to the new O-ring.
- Install the clamps [B] as shown.
- Tighten the holder bolts following the tightening sequence [1 ~ 3].

Torque - Throttle Body Assy Holder Bolts [C]: 10 N·m (1.0 kgf·m, 89 in·lb)

Throttle Body Assy Holder Clamp Bolts [D]: 2.0 N·m (0.20 kgf·m, 18 in·lb)

Upside View [E]

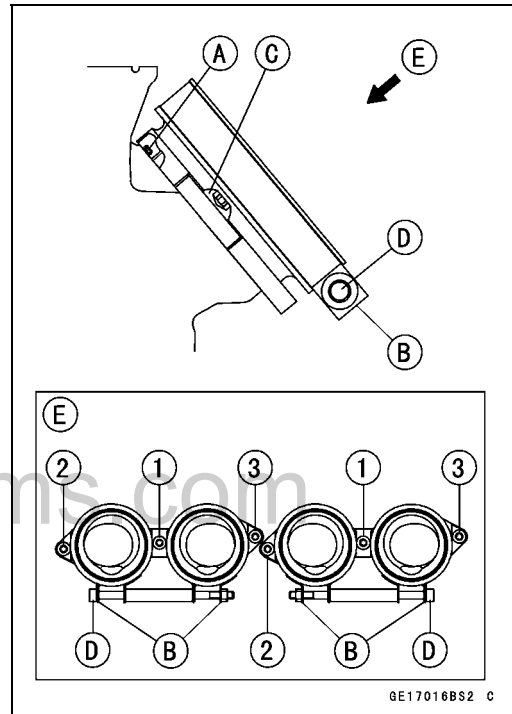

www.zxforums.com

Muffler

⚠ WARNING

To avoid a serious burn, do not remove the muffler when the engine is still hot. Wait until the muffler cool down.

Muffler Body Removal

- Remove:
 - Seat Cover (see Seat Cover Removal in the Frame chapter)
 - Bolts [A]
 - Right Rear Footpeg Bracket [B] with Cover [C]

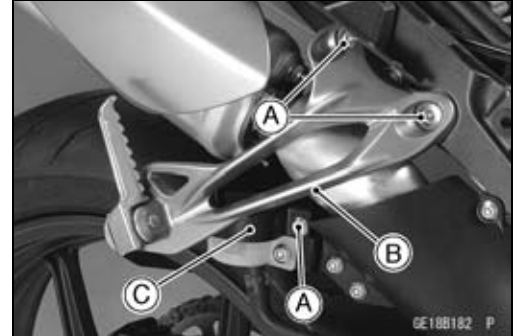

- Remove:
 - Right Muffler Body Assembly Nuts [A]
 - Right Muffler Body Mounting Bolt [B]
- Remove the right muffler body [C] to backward.
- Remove the bolt [D] and muffler body cover [E] as necessary.

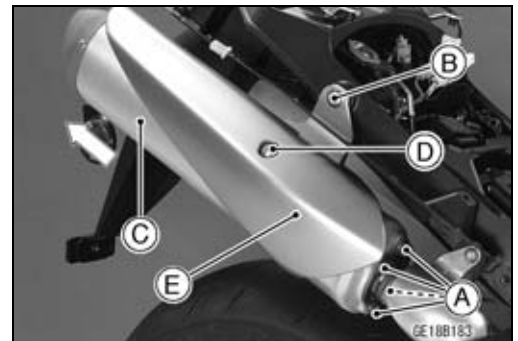

- Remove:
 - Bolts [A]
 - Left Rear Footpeg Bracket [B]

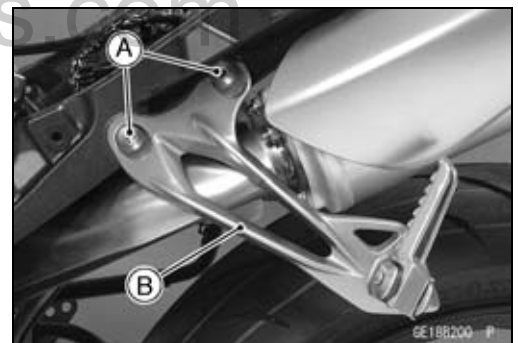

- Remove:
 - Left Muffler Body Assembly Nuts [A]
 - Left Muffler Body Mounting Bolt [B]
- Remove the left muffler body [C] to backward.
- Remove the bolt [D] and muffler body cover [E] as necessary.

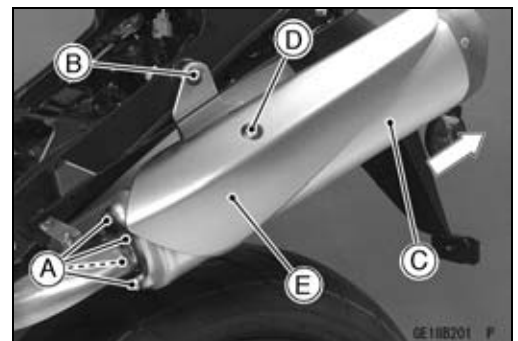

Muffler

Muffler Body Installation

- ★ If the muffler body cover [A] was removed, install it.
- Fit the dampers [B] of the muffler body into the slots [C] in the muffler cover.

Torque - Muffler Body Cover Bolts [D]: 7.0 N·m (0.70 kgf·m, 62 in·lb)

- Replace the muffler body gasket [E] with a new ones.
- Install the muffler body.
- Pass the muffler stay [F] through the hole [G] of the rear fender front [H].
- Tighten:

Torque - Muffler Body Assembly Nuts [I]: 22 N·m (2.2 kgf·m, 16 ft·lb)

Muffler Body Mounting Bolts [J]: 25 N·m (2.5 kgf·m, 18 ft·lb)

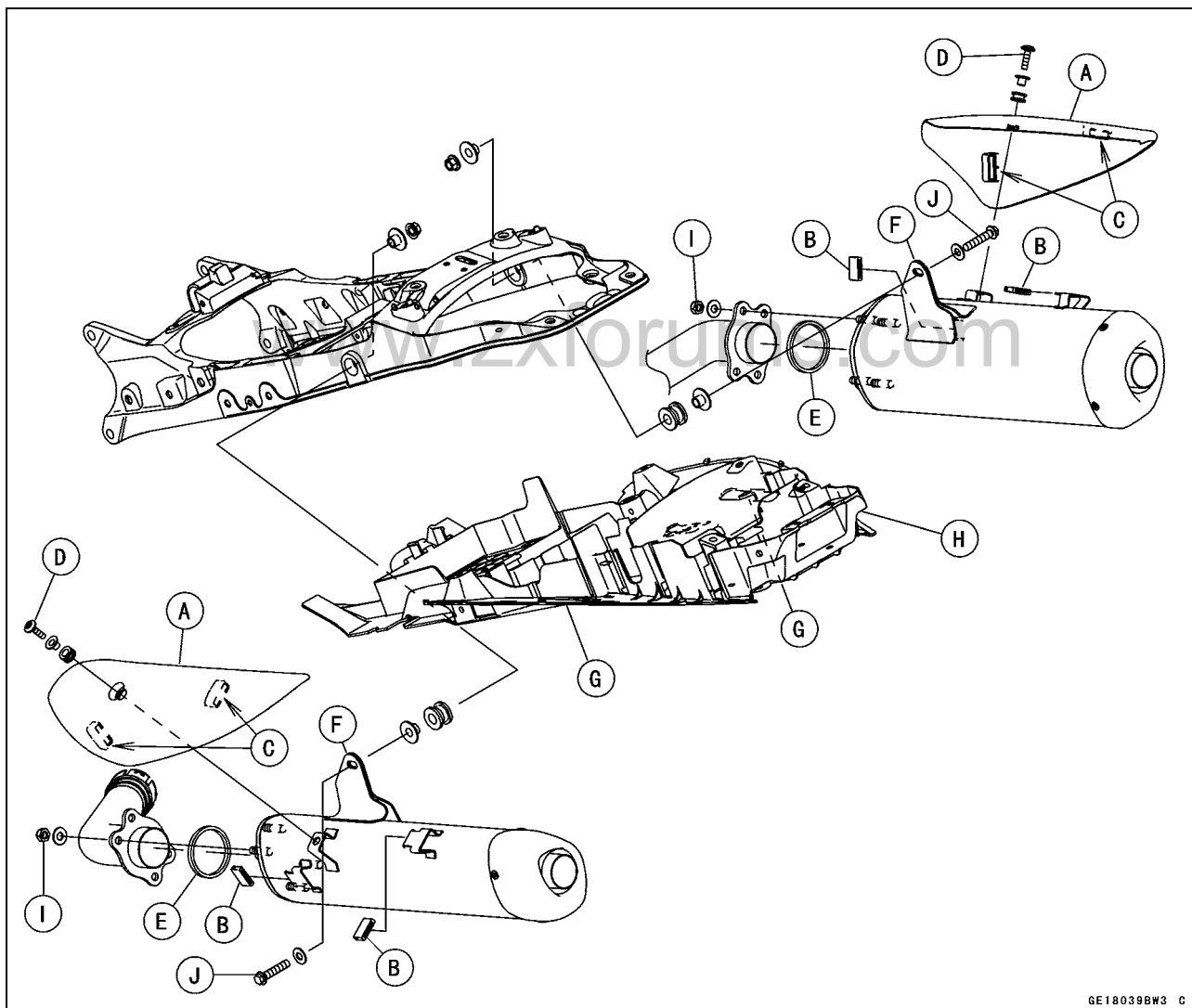

GE18039BW3 C

- Thoroughly warm up the engine, wait until the engine cools down, retighten all the bolts and nuts.
- Install the removed parts (see appropriate chapters).

Muffler

Middle and Rear Exhaust Pipe Removal

- Remove the left muffler body (see Muffler Body Removal).
- Loosen the rear exhaust pipe clamp bolt [A].
- Remove the rear exhaust pipe [B] from left side of motorcycle.



- Remove:
 - Right Muffler Body (see Muffler Body Removal)
 - Exhaust Butterfly Valve Cable Lower Ends (see Exhaust Butterfly Valve Cable Removal)
 - Lower Fairings (see Lower Fairing Removal in the Frame chapter)
 - Middle Exhaust Pipe Stay Bolt [A]
- Loosen the middle exhaust pipe clamp bolt [B].
- Remove the middle exhaust pipe [C] from right side of motorcycle.

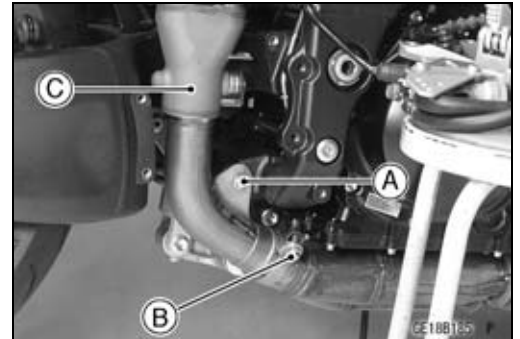

www.zxforums.com

Muffler

Middle and Rear Exhaust Pipe Installation

- Replace the middle exhaust pipe gasket [A] with a new one.
- Install the middle exhaust pipe gasket until it is bottomed so that the chamfer side (inner) faces front exhaust pipe [B].
- Install the middle exhaust pipe [C].
- Tighten:
 - Torque - Middle Exhaust Pipe Stay Bolt [D]: 25 N·m (2.5 kgf·m, 18 ft·lb)**
- Install the middle exhaust pipe clamp bolt [E] as shown.
 - Upside [F]
 - Outside [G]
 - 35° ~ 55° [H]
 - Front View [I]
- Tighten:
 - Torque - Middle Exhaust Pipe Clamp Bolt: 17 N·m (1.7 kgf·m, 13 ft·lb)**
- Replace the rear exhaust pipe gasket [J] with a new one.
- Install the rear exhaust pipe gasket until it is bottomed so that the chamfer side (outer) faces rear exhaust pipe [K].
- Install the rear exhaust pipe clamp bolt [L] as shown.
- Fit the projection [M] of the rear exhaust pipe into the slot [N] in the clamp.
- Install the rear exhaust pipe.
- Fit the damper [O] of the rear exhaust pipe into the stopper [P] of the middle exhaust pipe.
- Install the left and right muffler body (see Muffler Body Installation).
- Tighten:

Torque - Rear Exhaust Pipe Clamp Bolt: 17 N·m (1.7 kgf·m, 13 ft·lb)

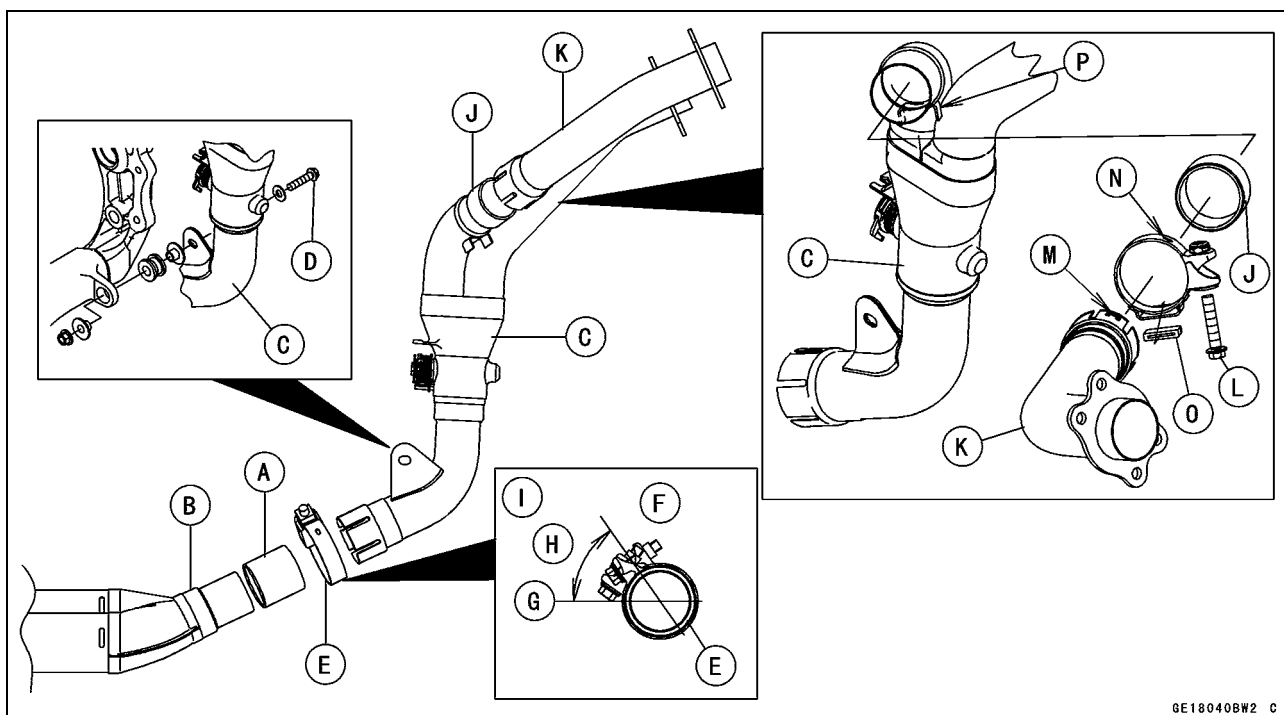

GE180408W2 C

Muffler

- Install the exhaust butterfly valve cable, and adjust (see Exhaust Butterfly Valve Cable Installation).
- Thoroughly warm up the engine, wait until the engine cools down, retighten all the bolts.
- Install the removed parts (see appropriate chapters).

Front Exhaust Pipe Removal

- Remove:
 - Radiator (see Radiator and Radiator Fan Removal in the Cooling System chapter)
 - Oxygen Sensor Lead Connectors (Europe Models, see Oxygen Sensor Removal (Europe Models) in the Electrical System chapter)
 - Front Exhaust Pipe Holder Nuts [A]

- Loosen the middle exhaust pipe clamp bolt [A].
- Remove the front exhaust pipe [B] to forward.

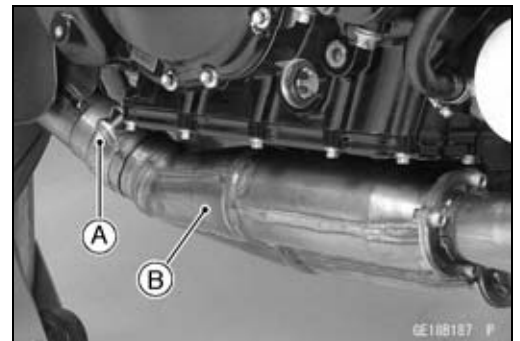

www.zxforums.com

Muffler

Front Exhaust Pipe Installation

- Replace the front exhaust pipe gaskets [A] with new ones.
- Replace the middle exhaust pipe gasket [B] with a new one.
- Install the middle exhaust pipe gasket until it is bottomed so that the chamfer side (inner) faces front exhaust pipe.
- Install the front exhaust pipe [C].
- Install the middle exhaust pipe clamp bolt [D] as shown.
 - Upside [E]
 - Outside [F]
 - 35° ~ 55° [G]
 - Front View [H]
- Tighten:
 - Torque - Front Exhaust Pipe Holder Nuts [I]: 17 N·m (1.7 kgf·m, 13 ft·lb)**
 - Middle Exhaust Pipe Clamp Bolt: 17 N·m (1.7 kgf·m, 13 ft·lb)**
- For the Europe Models, Route the oxygen sensor leads correctly (see Cable, Wire, and Hose Routing section in the Appendix chapter).

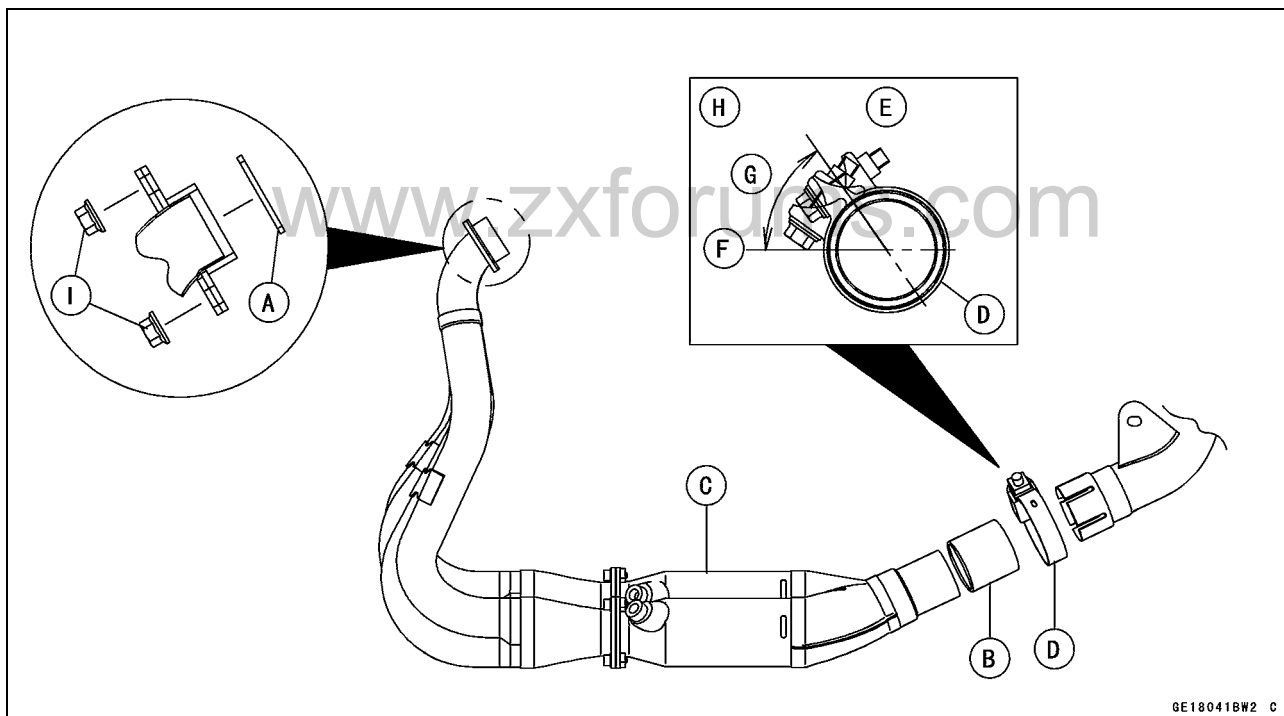

- Install the radiator (see Radiator and Radiator Fan Installation in the Cooling System chapter).
- Thoroughly warm up the engine, wait until the engine cools down, retighten all the bolt and nuts.

Muffler

Exhaust Butterfly Valve Cable Removal

- Remove the seat cover (see Seat Cover Removal in the Frame chapter).
- Slide the dust covers [A].
- Loosen the locknuts [B], and turn the adjusters [C] to give the cable plenty of paly.

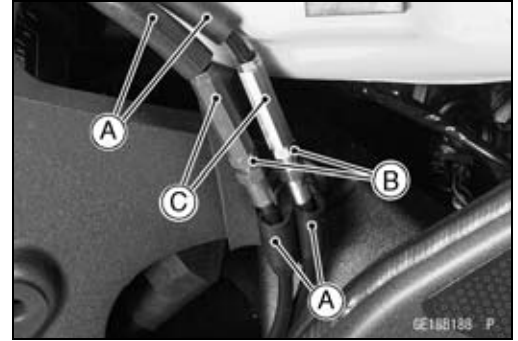

- Remove the clamp [A].
- Remove the exhaust butterfly valve cable upper ends [B] from the pulley [C].

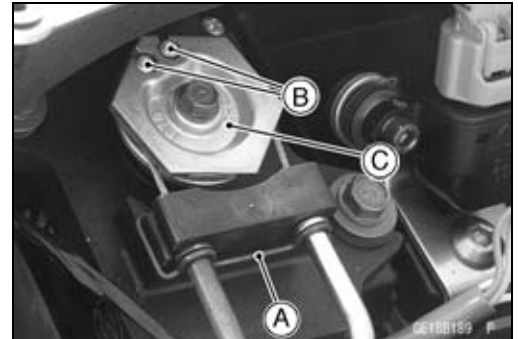

- Remove:
 - Bolts [A]
 - Bracket Bolts [B]
 - Right Footpeg Bracket [C] with Rear Brake Reservoir [D]
- Remove the brake hose [E] from the clamp [F].

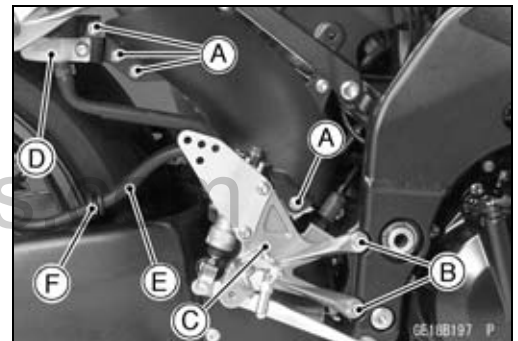

- Unscrew the mounting bolts [A], and detach the rear caliper [B] from the disc.

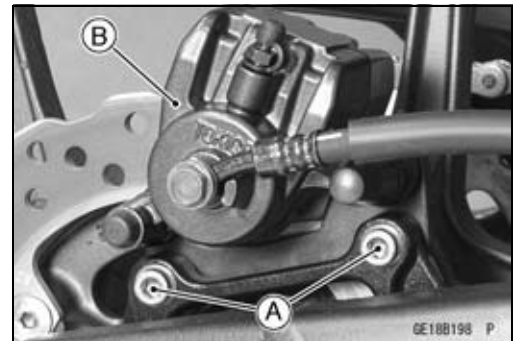

- Remove:
 - Right Rear Footpeg Bracket (see Muffler Body Removal)
 - Bolts [A]
 - Upper Cover [B]
 - Lower Heat Guard [C]

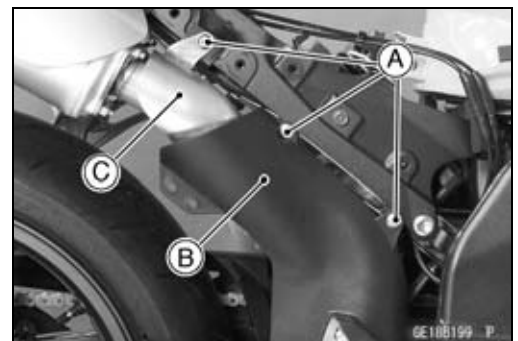

Muffler

- Remove:
Bolts [A]
Lower Cover [B]

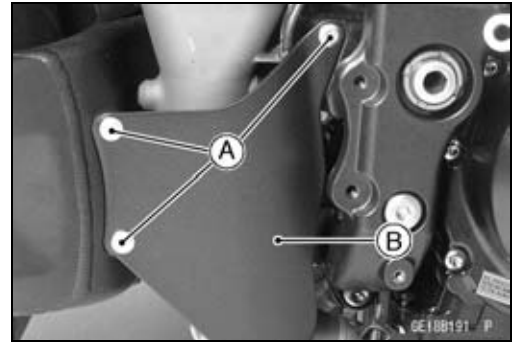

- Loosen the locknuts [A].
- Remove the exhaust butterfly valve cable lower ends [B] from the pulley [C].
- Pull the exhaust butterfly valve cables out of frame. Front View [D]

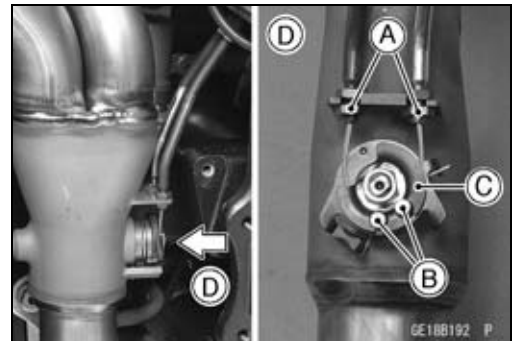

Exhaust Butterfly Valve Cable Installation

- Route the butterfly valve cables correctly (see Cable, Wire and Hose Routing section in the Appendix chapter).
- Install the exhaust butterfly valve cable lower ends to the pulley of middle exhaust pipe [A].
Open Cable (Yellow) [B]
Close Cable (Dark Green) [C]
6 mm (0.24 in.) [D]
Front View [E]
- Tighten:
Torque - Exhaust Butterfly Valve Cable Locknuts: 7.0 N·m (0.70 kgf·m, 62 in·lb)

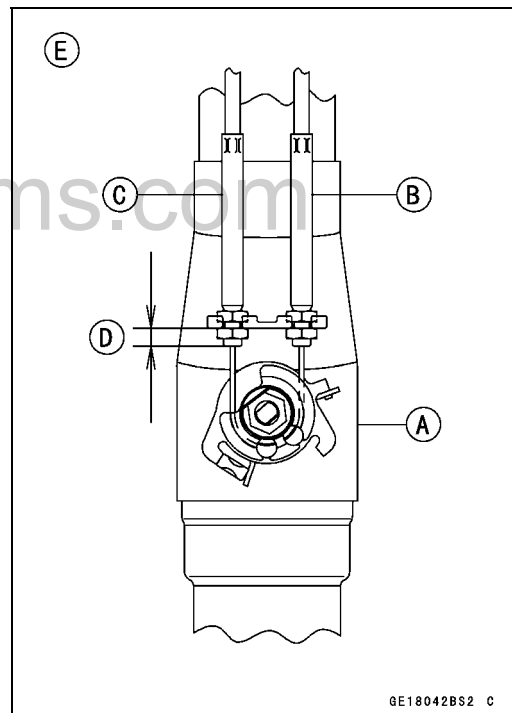

- Confirm whether it is an angle shown in figure.

NOTE

○Correct the position electrically after confirming use is discontinued, and there is no damage when differing from the angle of shown in the figure.

- ★If the angle is wrong, adjust the pulley (see Exhaust Butterfly Valve Actuator Installation in the Fuel System (DFI) chapter).
41.7° ±7° [A]

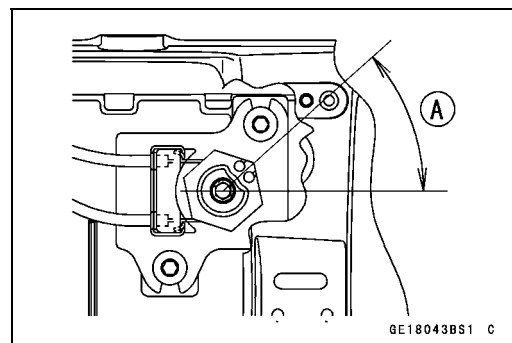

CAUTION

Do not correct it with the tool, forcibly.

Muffler**CAUTION**

To keep the correct exhaust butterfly valve position, adjust the open cable first.

- Install the close cable (green) [A].
- Install the open cable (yellow) [B] and adjust the adjuster [C] until the clearance of part [D] of figure come to 0 mm (0 in.).

CAUTION

Do not overstretch.

- Tighten:
 - Torque - Exhaust Butterfly Valve Cable Adjuster Locknut:**
7.0 N·m (0.70 kgf·m, 62 in·lb)
- Adjust the adjuster [E] of the close cable until the clearance of part [D] of figure come to 0 mm (0 in.).
- After the adjust, return the locknut to the half from one rotation.
- Tighten:
 - Torque - Exhaust Butterfly Valve Cable Adjuster Locknut:**
7.0 N·m (0.70 kgf·m, 62 in·lb)
- Cover the dust covers as shown.
 - 10 mm (0.39 in.) or less [F]
 - 15 mm (0.59 in.) or less [G]
- Install the clamp [H]

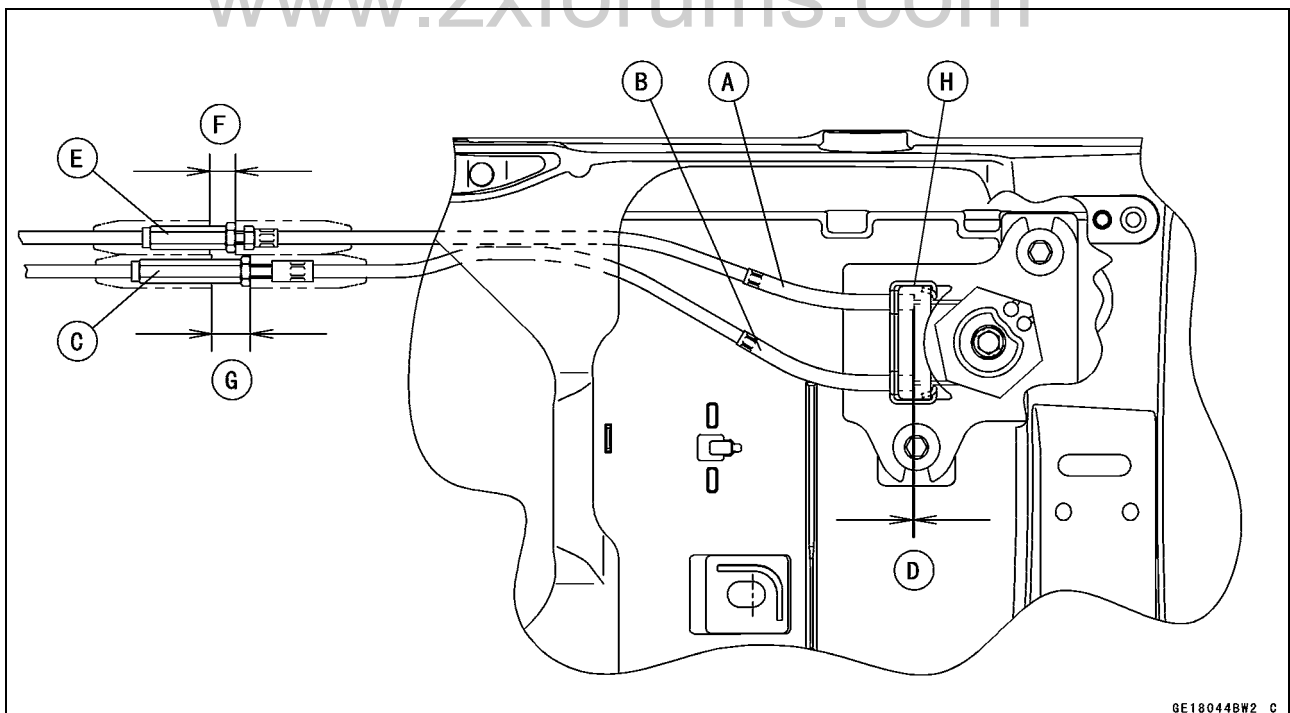

- Apply a non-permanent locking agent to the threads of the lower cover bolts, and tighten it.
- Install the other removed parts (see appropriate chapters).

www.zxforums.com

Clutch

Table of Contents

Exploded View	6-2
Specifications	6-4
Special Tool and Sealant	6-5
Clutch Lever and Cable	6-6
Clutch Lever Free Play Inspection	6-6
Clutch Lever Free Play Adjustment	6-6
Cable Removal	6-6
Cable Installation	6-6
Cable Lubrication	6-6
Clutch Lever Installation	6-6
Clutch Cover	6-7
Clutch Cover Removal	6-7
Clutch Cover Installation	6-7
Release Shaft Removal	6-7
Release Shaft Installation	6-8
Clutch Cover Disassembly	6-8
Clutch Cover Assembly	6-9
Clutch	6-10
Clutch Removal	6-10
Clutch Installation	6-12
Spring Plate Free Play Measurement	6-15
Spring Plate Free Play Adjustment	6-16
Clutch Plate, Wear, Damage Inspection	6-16
Clutch Plate Warp Inspection	6-17
Clutch Spring Free Length Measurement	6-17
Damper Cam Inspection	6-17

Exploded View

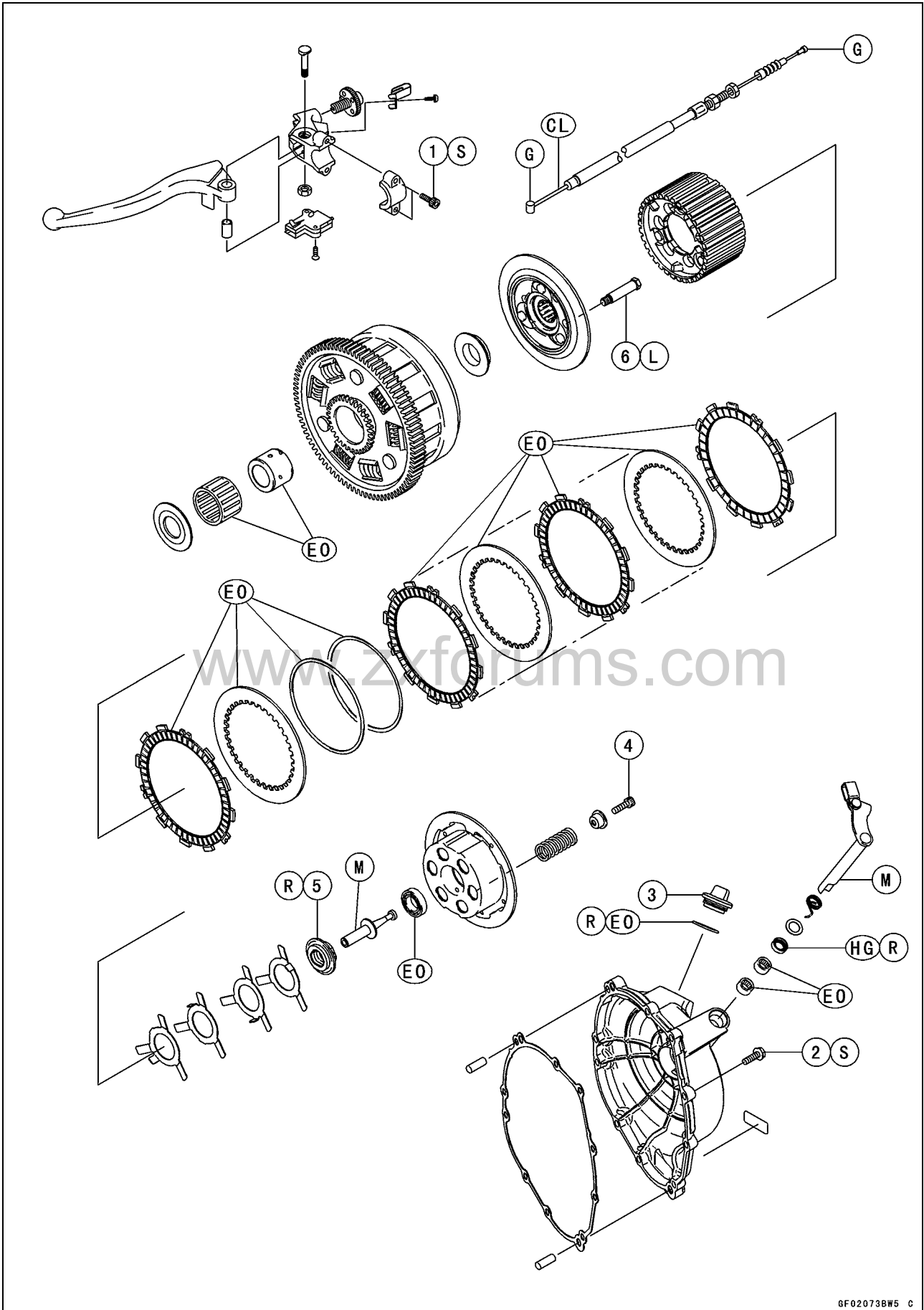

GF02073BW5 C

Exploded View

No.	Fastener	Torque			Remarks
		N·m	kgf·m	ft·lb	
1	Clutch Lever Clamp Bolts	7.8	0.80	69 in·lb	S
2	Clutch Cover Mounting Bolts	10	1.0	89 in·lb	S
3	Oil Filler Plug	–	–	–	Hand-tighten
4	Clutch Spring Bolts	9.8	1.0	87 in·lb	
5	Clutch Hub Nut	130	13.3	96	R
6	Sub Clutch Hub Bolts	25	2.5	18	L

CL: Apply cable lubricant.

EO: Apply engine oil.

G: Apply grease.

G: Apply grease.

HG: Apply high-temperature grease.

R: Replacement Parts

S: Follow the specified tightening sequence.

www.zxforums.com

Specifications

Item	Standard	Service Limit
Clutch Lever Free Play	2 ~ 3 mm (0.08 ~ 0.12 in.)	— — —
Clutch		
Spring Plate Free Play	(Usable Range) 0.05 ~ 0.70 mm (0.002 ~ 0.028 in.)	— — —
Clutch Plate Assembly Length	(Reference) 53.5 mm (2.11 in.)	— — —
Friction Plate Thickness	2.72 ~ 2.88 mm (0.107 ~ 0.113 in.)	2.6 mm (0.102 in.)
Friction and Steel Plate Warp	0.15 mm (0.0059 in.) or less	0.3 mm (0.012 in.)
Clutch Spring Free Length	43.5 mm (1.71 in.)	42.1 mm (1.66 in.)

www.zxforums.com

Special Tool and Sealant

Clutch Holder:
57001-1243

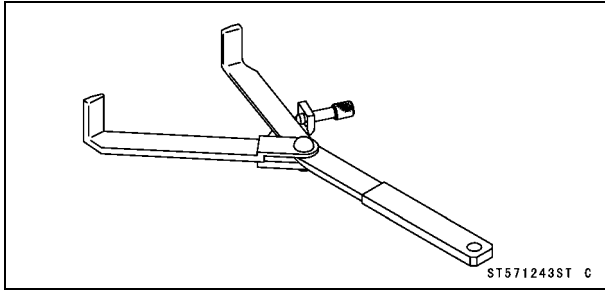

Kawasaki Bond (Silicone Sealant):
92104-0004

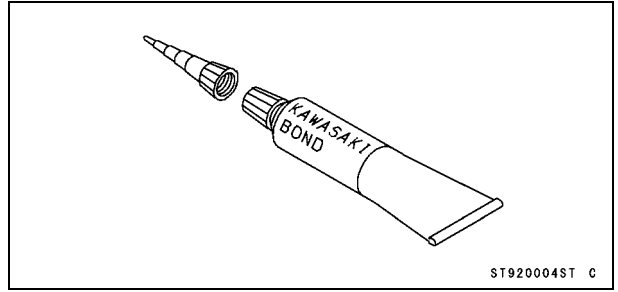

www.zxforums.com

Clutch Lever and Cable

Clutch Lever Free Play Inspection

- Refer to the Clutch Adjustment Inspection in the Periodic Maintenance chapter (see Clutch Adjustment Inspection in the Periodic Maintenance chapter).

Clutch Lever Free Play Adjustment

- Refer to the Clutch Adjustment Inspection in the Periodic Maintenance chapter (see Clutch Adjustment Inspection in the Periodic Maintenance chapter).

Cable Removal

- Remove the right middle fairing (see Middle Fairing Removal in the Frame chapter).
- Slide the dust cover [A] at the clutch cable lower end out of place.
- Loosen the nuts [B], and slide the lower end of the clutch cable to give the cable plenty of play.

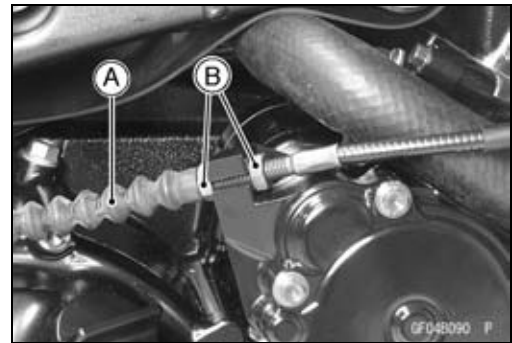

- Screw in the adjuster.
- Line up the slots [A] in the clutch lever and adjuster [B], and then free the cable from the lever.
- Free the clutch inner cable tip from the clutch release lever.
- Push the release lever toward the front of the motorcycle and tape the release lever to the clutch cover to prevent the release shaft from falling out.
- Pull the clutch cable out of the frame.

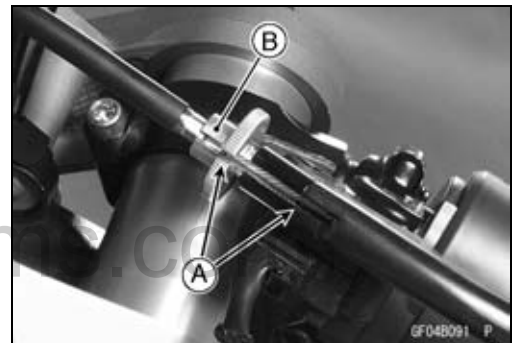

Cable Installation

- Run the clutch cable correctly (see Cable, Wire, and Hose Routing section in the Appendix chapter).
- Adjust the clutch cable (see Clutch Adjustment Inspection in the Periodic Maintenance chapter).
- Install the right middle fairing (see Middle Fairing Installation in the Frame chapter).

Cable Lubrication

- Refer to the Chassis Parts Lubrication in the Periodic Maintenance chapter (see Chassis Parts Lubrication in the Periodic Maintenance chapter).

Clutch Lever Installation

- Install the clutch lever so that the mating surface [A] of the clutch lever clamp is aligned with the mating surface [B] of the switch housing.
- Tighten the upper clamp bolt first, and then the lower clamp bolt. There will be a gap at the lower part of the clamp after tightening.

Torque - Clutch Lever Clamp Bolts: 7.8 N·m (0.80 kgf·m, 69 in·lb)

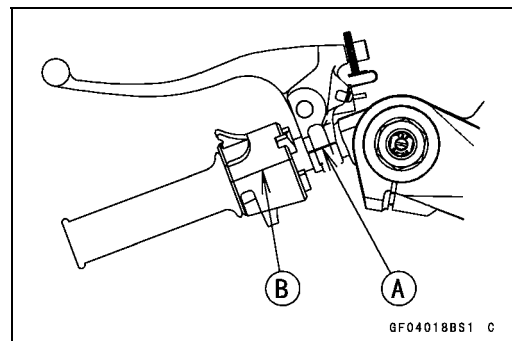

Clutch Cover

Clutch Cover Removal

- Drain the engine oil (see Engine Oil Change in the Periodic Maintenance chapter).
- Remove:
 - Right Lower Fairing (see Lower Fairing Removal in the Frame chapter)
 - Clutch Cable Lower End [A] (see Cable Removal)
- Loosen the clutch cover mounting bolts as shown sequence [1 ~ 10] in the figure, and remove them.
- Turn the release lever [A] toward the rear as shown, and remove the clutch cover [B].
About 90° [C]

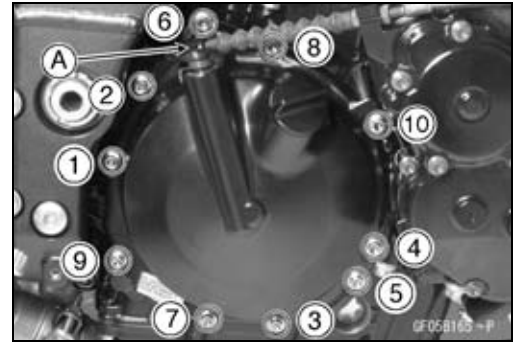

Clutch Cover Installation

- Apply silicone sealant to the area [A] where the mating surface of the crankcase touches the clutch cover gasket.
Sealant - Kawasaki Bond (Silicone Sealant): 92104-0004
- Install the dowel pins [B].
- Replace the clutch cover gasket with a new one.

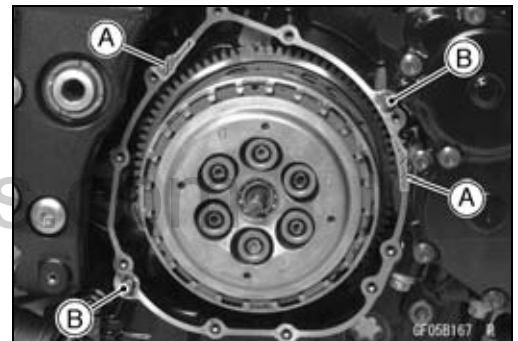

- Tighten the clutch cover mounting bolts following the tightening sequence [1 ~ 10].

Torque - Clutch Cover Mounting Bolts: 10 N·m (1.0 kgf·m, 89 in·lb)

- Install:
 - Clutch Cable Lower End (see Cable Installation)
 - Right Lower Fairing (see Lower Fairing Installation in the Frame chapter)

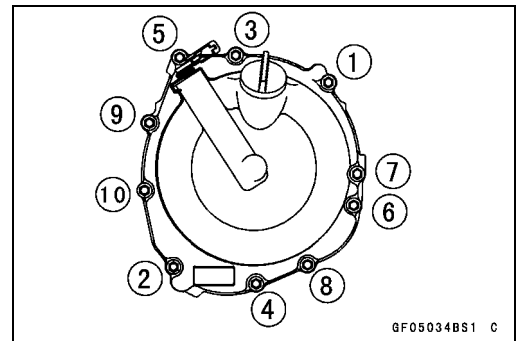

Release Shaft Removal

CAUTION

Do not remove the clutch release lever and shaft assembly unless it is absolutely necessary. If removed, the oil seal replacement may be required.

- Remove the clutch cover (see Clutch Cover Removal).
- Pull the release lever and shaft assembly [A] straight out of the clutch cover.



Clutch Cover

Release Shaft Installation

- Apply high-temperature grease to the oil seal lips on the upper ridge of the clutch cover.
- Apply oil to the needle bearings in the hole of the clutch cover.
- Apply molybdenum disulfide grease to the pusher-holding portion [A] on the release shaft.
- Install the washer [B] and spring [C].
- Insert the release shaft straight into the upper hole of the clutch cover.

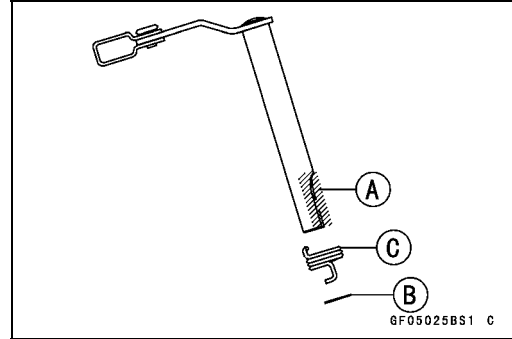

CAUTION

When inserting the release shaft, be careful not to remove the spring of the oil seal.

- Fit the spring [A] as shown.
Viewed from Rear [B]
Release Shaft [C]
Clutch Cover [D]
- Install the clutch cover (see Clutch Cover Installation).

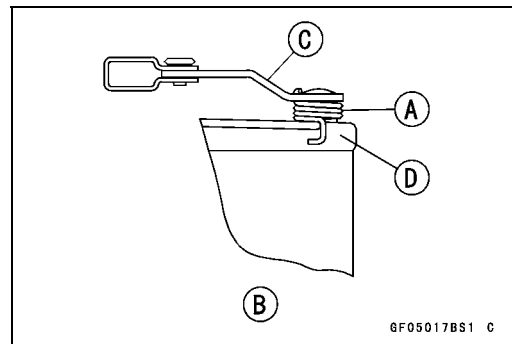

Clutch Cover Disassembly

- Remove:
 - Clutch Cover (see Clutch Cover Removal)
 - Release Lever and Shaft Assembly (see Release Shaft Removal)
 - Oil Seal [A]
 - Oil Filler Plug [B]



- Remove the needle bearings [A].

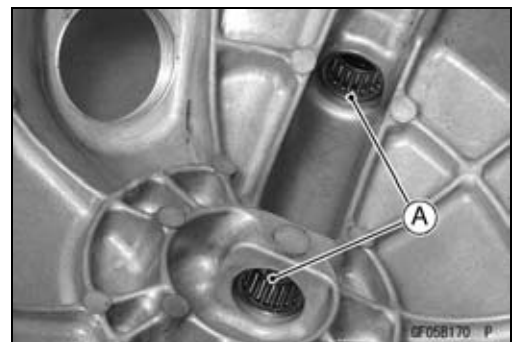

Clutch Cover

Clutch Cover Assembly

- Replace the needle bearings and oil seal with new ones.

NOTE

- *Install the needle bearings so that the manufacture's make face out.*
- Install the needle bearings [A] and oil seal [B] position as shown.
- Press the lower bearing, do not protrude from the boss [C] of the clutch cover.
- Press the upper bearing so that the bearing surface [D] is flush with the housing end of clutch cover [E].
- Press the oil seal until the bottom.
- Replace the O-ring [A] of the oil filler plug [B] with a new one.
- Apply engine oil to the new O-ring.
- Install the oil filler plug.

Torque - Oil Filler Plug: Hand-tighten

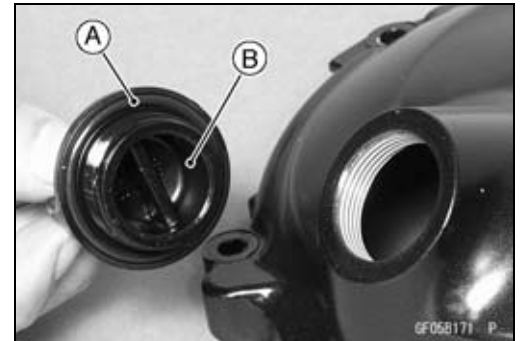
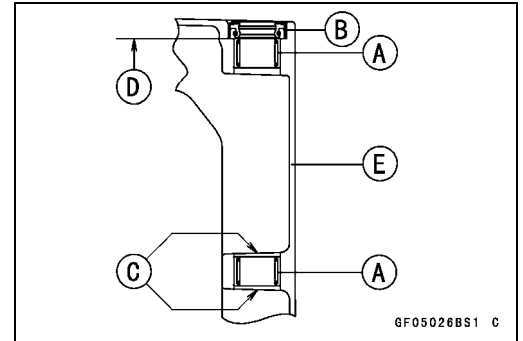

www.zxforums.com

Clutch

Clutch Removal

- Remove:
 - Clutch Cover (see Clutch Cover Removal)
 - Clutch Spring Bolts [A]
 - Clutch Springs (with Clutch Spring Holders)
 - Clutch Spring Plate [B] (with Bearing)
 - Pusher [C]

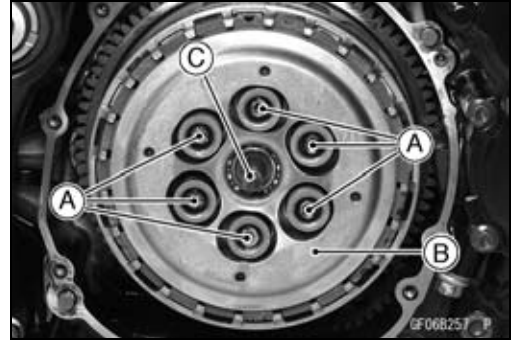

- Remove:
 - Friction Plates (10) [A]
 - Steel Plates (9) [B]
 - Spring [C]
 - Spring Seat [D]

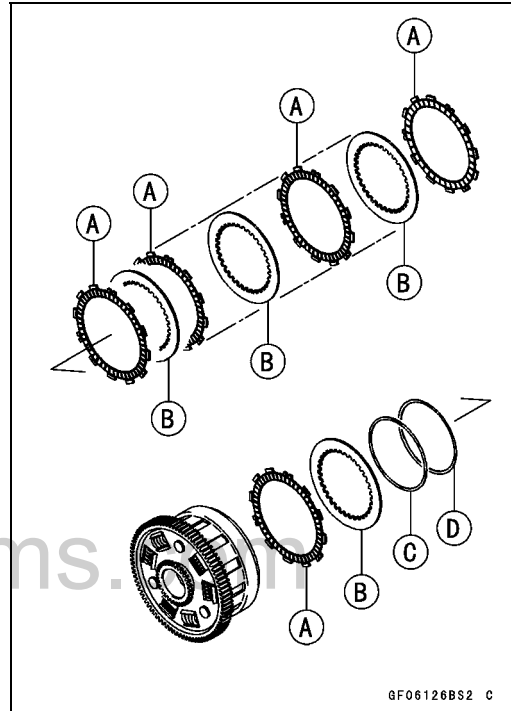

- Hold the sub clutch hub [A] steady with the clutch holder [B], and remove the nut [C].

Special Tool - Clutch Holder: 57001-1243



- Use the clutch holder with sharpened hook nose by grinding.

Special Tool - Clutch Holder: 57001-1243

- Grind the hook nose by 0.5 mm (0.02 in.) as shown in the figure.

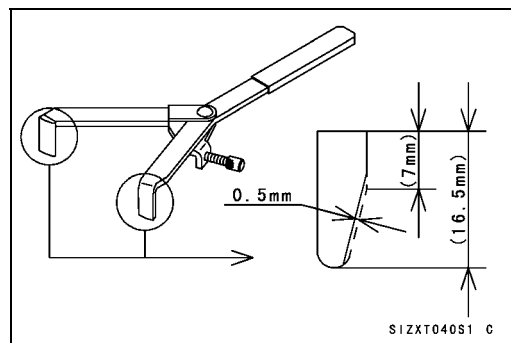

Clutch

- Remove:
 - Torque Limiter Springs [A]
 - Sub Clutch Hub [B]
 - Clutch Hub [C]
 - Spacer [D]
- Remove the sub clutch hub bolts [E] as necessary.

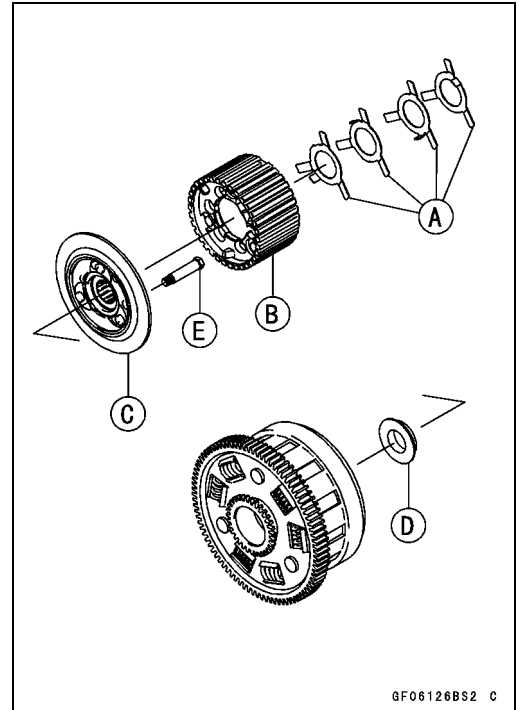

- Using the two 4 mm (0.16 in.) screws [A], pull out the sleeve [B], needle bearing [C] and clutch housing [D].
- Remove the spacer.

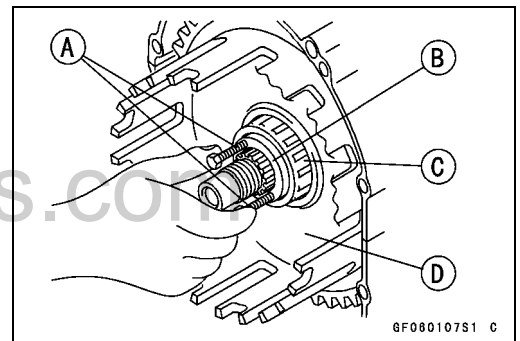

Clutch

Clutch Installation

- Install the spacer [A] so that the circle mark [B] faces outward.

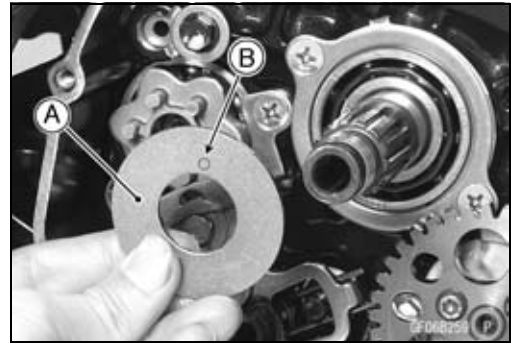

- Engage the clutch housing gear [A] and oil pump drive gear [B] with the crankshaft primary gear [C] and oil pump gear [D].

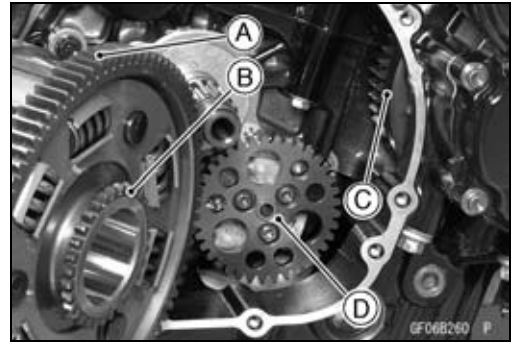

- Install:
 - Needle Bearing [A]
 - Sleeve [B]
- Apply engine oil to the sleeve and needle bearing.
- Install the spacer [C] so that the stepped side [D] faces outward.

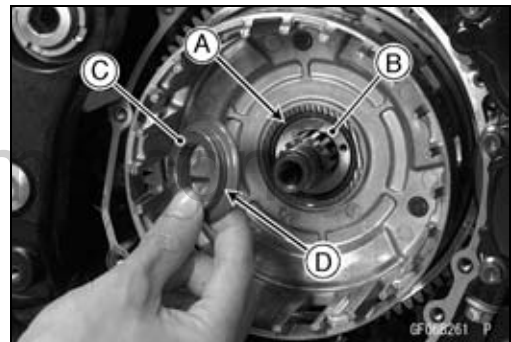

- ★ If the sub clutch hub bolts was removed, install it.
- Apply a non-permanent locking agent to the threads of the sub clutch hub bolts, and tighten it.

Torque - Sub Clutch Hub Bolts: 25 N·m (2.5 kgf·m, 18 ft·lb)

- Install the clutch hub [A] on the crankshaft.
- Align the damper cam [B] of the sub clutch hub [C] to the cam followers [D] of the clutch hub.

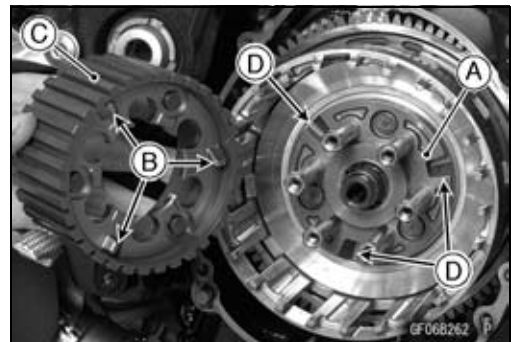

- Install the four torque limiter springs [A] as shown.
- First Torque Limiter Spring Tang [B]

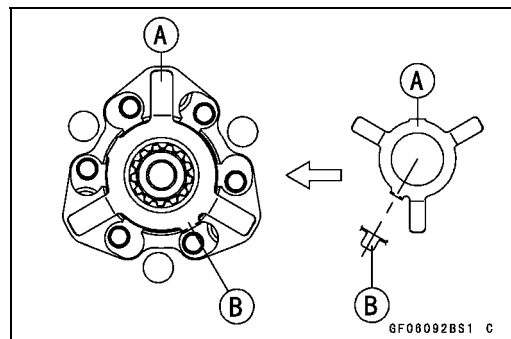

Clutch

- Second Torque Limiter Spring
Tang [B]

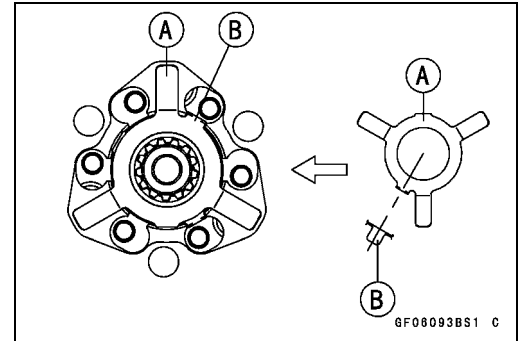

- Third Torque Limiter Spring
Tang [B]

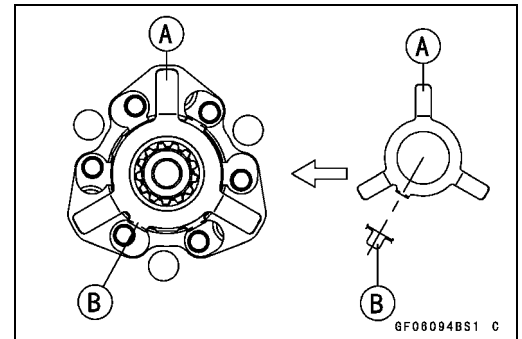

- Fourth Torque Limiter Spring
Tang [B]

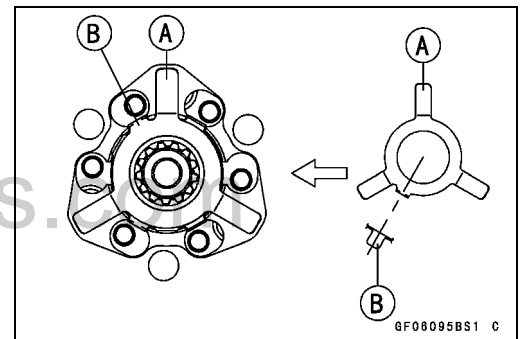

- Replace the clutch hub nut [A] with a new one.
- Hold the sub clutch hub [B] steady with the clutch holder [C], and tighten the clutch hub nut.

Special Tool - Clutch Holder: 57001-1243

Torque - Clutch Hub Nut: 130 N·m (13.3 kgf·m, 96 ft·lb)



Clutch

- Install the following as shown.
 - Friction Plates (9) [A]
 - Steel Plates (9) [B]
 - Spring Seat [C]
 - Spring [D]
- Install the spring seat and spring between first steel plate and second steel plate.

CAUTION

If new dry friction plates and steel plates are installed, apply engine oil to the surface of each plate to avoid clutch plate seizure.

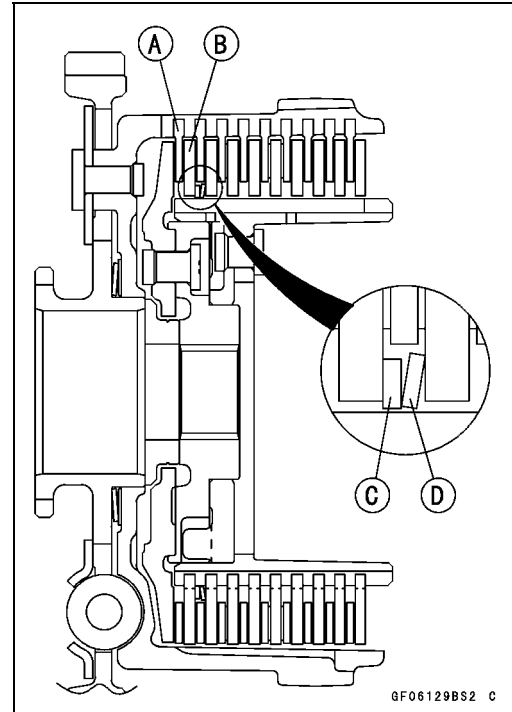

- Install the last friction plate [A] fitting the tangs in the grooves in the housing as shown.

www.zxforums.com



- Apply molybdenum disulfide grease to the pusher end [A].
- Install the pusher [B] to the drive shaft direction as shown.

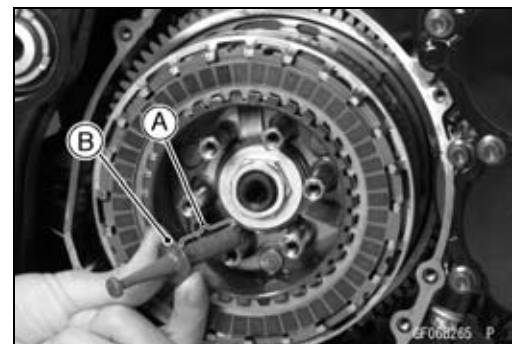

- Apply engine oil to the sliding surfaces of the bearing [A].
- Align the grooves [B] of the spring plate [C] to the grooves [D] of the sub clutch hub [E] to install the spring plate on the sub clutch hub.
- Install the clutch springs and spring holders, and tighten the clutch spring bolts.

Torque - Clutch Spring Bolts: 11 N·m (1.1 kgf·m, 97 in·lb)

- Install the clutch cover (see Clutch Cover Installation).

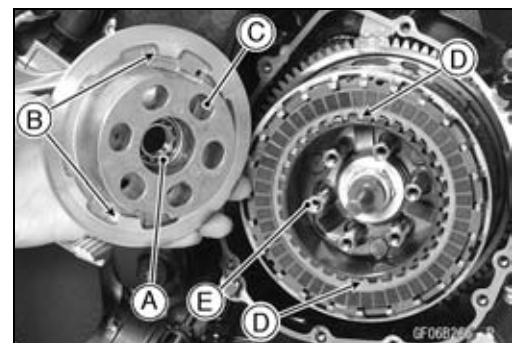

Clutch

Spring Plate Free Play Measurement

Insufficient clutch free play will cause the engine braking effect to be more sudden, resulting in rear wheel hop. On the other hand, if the free play is excessive, the clutch lever may feel "spongy" or pulsate when pulled.

- Hold an extra drive shaft in a vise and install the following clutch parts on the shaft (see Clutch Installation).
 - Spacer [A]
 - Needle Bearing [B]
 - Sleeve [C]
 - Clutch Housing [D]
 - Spacer [E]
 - Clutch Hub [F]
 - Sub Clutch Hub [G]
 - Friction Plates [H]
 - Steel Plates [I]
 - Spring Seat [J]
 - Spring [K]
 - Clutch Spring Plate [L]

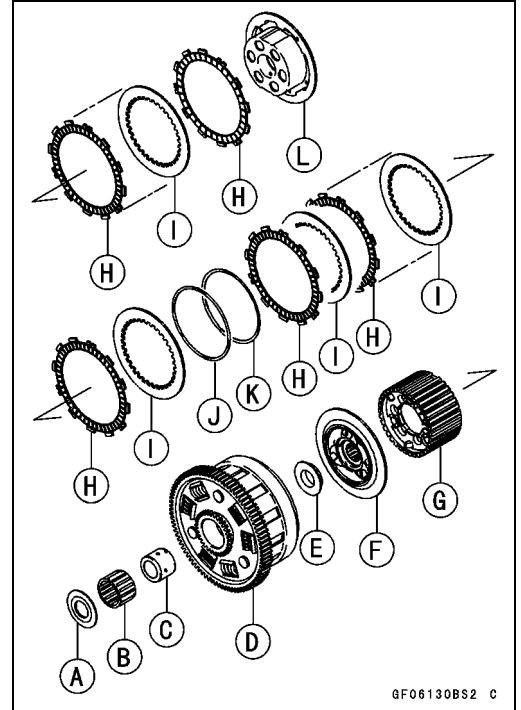

- Engage the clutch hub with the sub clutch hub.
- To measure the free play, set a dial gauge [A] against the raised center [B] of the clutch spring plate.
- Move the clutch housing gear back and forth [C]. The difference between the highest and lowest gauge readings is the amount of free play.
- Measure the spring plate free play.

Spring Plate Free Play

Usable Range: 0.05 ~ 0.70 mm (0.002 ~ 0.028 in.)

- ★ If the free play is not within the usable range, change all of the friction plate and measure the free play again.
- ★ If the free play is not within the usable range, adjust the free play (see Spring Plate Free Play Adjustment).

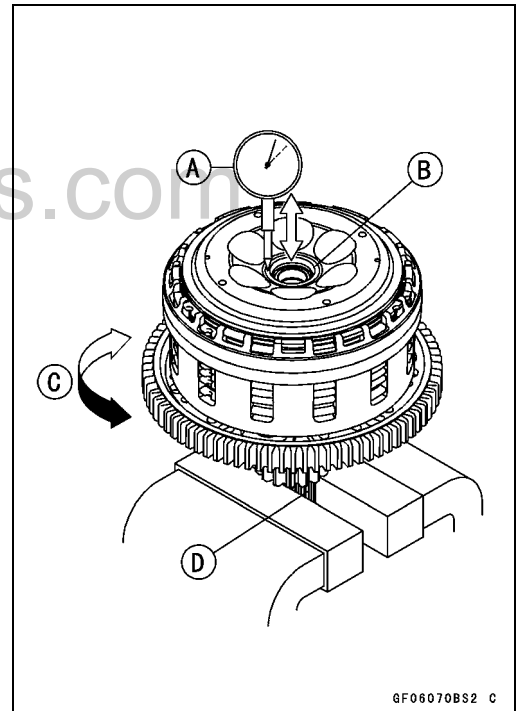

Clutch

Spring Plate Free Play Adjustment

NOTE

- The free play adjustment is performed by replacing the steel plate(s).
- Measure the clutch spring plate free play (see Clutch Spring Plate Free Play Measurement), and then replace the steel plate(s) which brings the free play within the usable range.

Spring Plate Free Play

Usable Range: 0.05 ~ 0.70 mm (0.002 ~ 0.028 in.)

- Replace the following steel plate(s).

Thickness	Part Number
2.3 mm (0.090 in.)	13089-0008
2.6 mm (0.102 in.)	13089-0009
2.9 mm (0.114 in.) (STD)	13089-1093

Clutch Plate Assembly Length (Reference Information)

- Assemble the following parts.

- Clutch Hub [A]
- Spring Seat [B]
- Spring [C]
- Sub Clutch Hub [D]
- Sub Clutch Hub Bolts [E]
- New Friction Plates [F]
- Steel Plates [G]
- Spring Plate [H]
- Clutch Springs [I]
- Clutch Spring Holders [J]
- Clutch Spring Bolts [K]

Torque - Clutch Spring Bolts: 9.8 N·m (1.0 kgf·m, 87 in·lb)

- Measure the clutch plate assembly length [L].

Clutch Plate Assembly Length (Reference)

53.5 mm (2.11 in.)

NOTE

- The length of the clutch plate assembly changes by the steel plate thickness.

Clutch Plate, Wear, Damage Inspection

- Visually inspect the friction and steel plates for signs of seizure, overheating (discoloration), or uneven wear.
- Measure the thickness of each friction plate [A] at several points.
- ★ If any plates show signs of damage, or if they have worn past the service limit, replace them with new ones.

Friction Plate Thickness

Standard: 2.72 ~ 2.88 mm (0.107 ~ 0.113 in.)

Service Limit: 2.6 mm (0.102 in.)

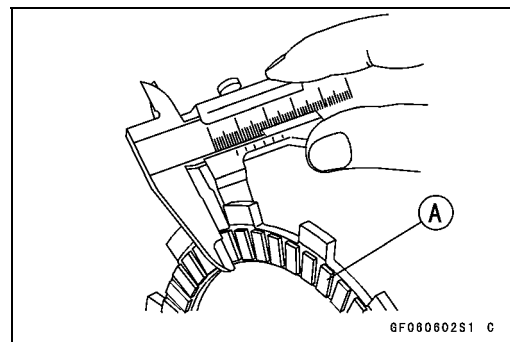
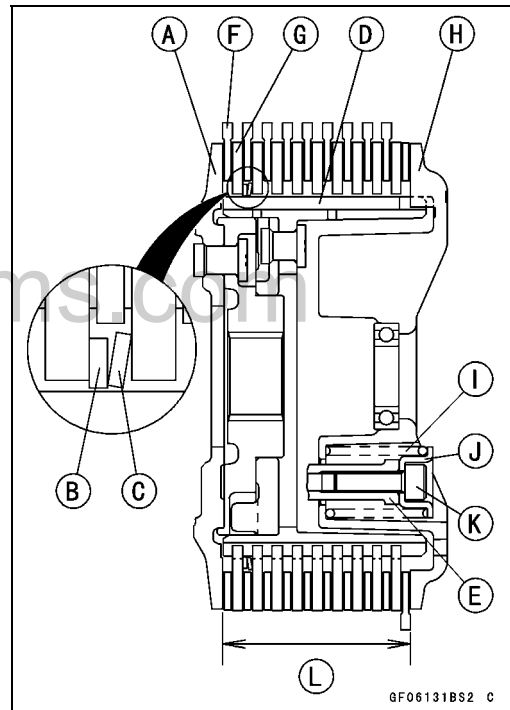

Clutch

Clutch Plate Warp Inspection

- Place each friction plate or steel plate on a surface plate and measure the gap between the surface plate [A] and each friction plate or steel plate [B] with a thickness gauge [C]. The gap is the amount of friction or steel plate warp.
- ★ If any plate is warped over the service limit, replace it with a new one.

Friction and Steel Plate Warp

Standard: 0.15 mm (0.0059 in.) or less

Service Limit: 0.3 mm (0.012 in.)

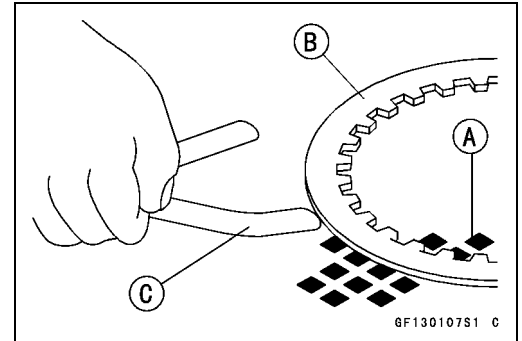

Clutch Spring Free Length Measurement

- Measure the free length of the clutch springs [A].
- ★ If any spring is shorter than the service limit, it must be replaced.

Clutch Spring Free Length

Standard: 43.5 mm (1.71 in.)

Service Limit: 42.1 mm (1.66 in.)

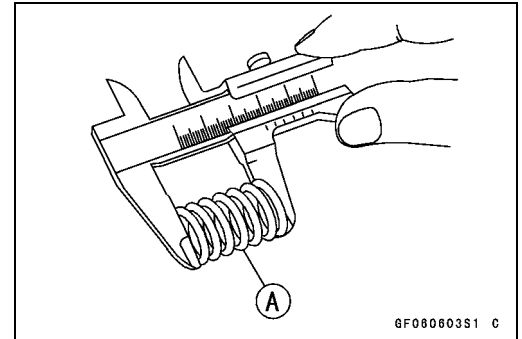

Damper Cam Inspection

- Remove the clutch (see Clutch Removal).
- Visually inspect the damper cam [A], cam follower [B], and the torque limiter spring [C].
- Replace the part if it appears damaged.

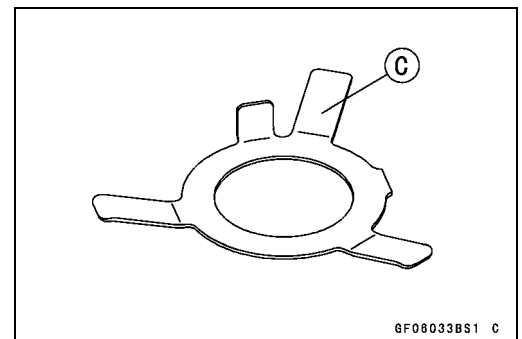
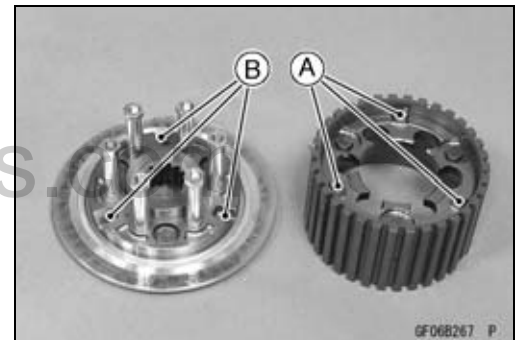

www.zxforums.com

Engine Lubrication System

Table of Contents

Exploded View.....	7-2
Engine Oil Flow Chart.....	7-4
Specifications	7-6
Special Tools and Sealant.....	7-7
Engine Oil and Oil Filter.....	7-8
Oil Level Inspection.....	7-8
Engine Oil Change.....	7-8
Oil Filter Replacement	7-8
Oil Pan.....	7-9
Oil Pan Removal.....	7-9
Oil Pan Installation.....	7-9
Oil Pressure Relief Valve.....	7-10
Oil Pressure Relief Valve Removal	7-10
Oil Pressure Relief Valve Installation	7-10
Oil Pressure Relief Valve Inspection.....	7-11
Oil Pump.....	7-12
Oil Pump Removal.....	7-12
Oil Pump Installation.....	7-12
Oil Pump Gear Removal.....	7-13
Oil Pump Gear Installation.....	7-13
Oil Cooler.....	7-15
Oil Cooler Removal.....	7-15
Oil Cooler Installation.....	7-15
Oil Cooler/Oil Filter Case Removal.....	7-15
Oil Cooler/Oil Filter Case Installation	7-16
Oil Pressure Measurement.....	7-17
Oil Pressure Measurement	7-17
Oil Pressure Switch	7-18
Oil Pressure Switch Removal	7-18
Oil Pressure Switch Installation	7-18

7-2 ENGINE LUBRICATION SYSTEM

Exploded View

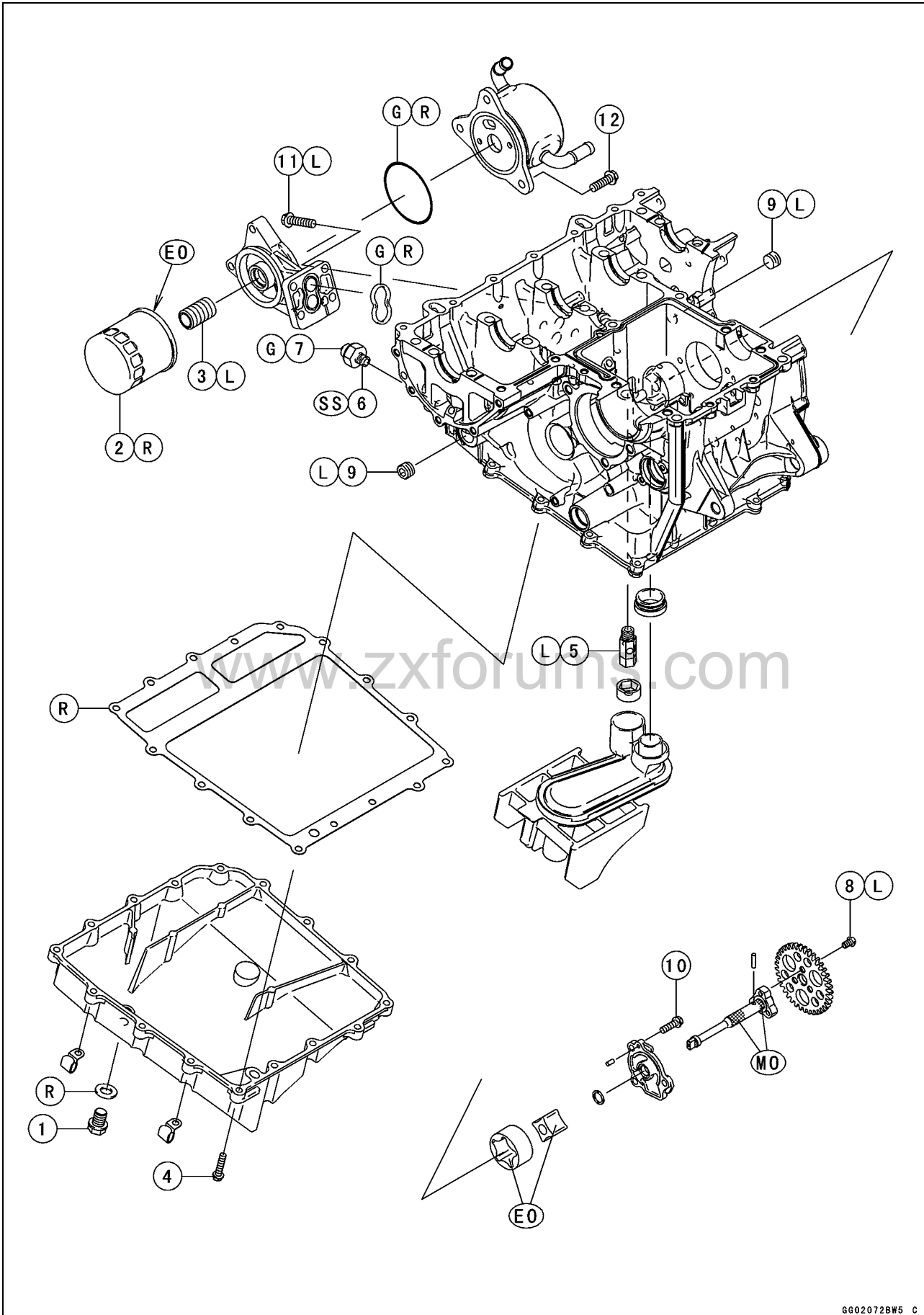

6002072BW5 C

Exploded View

No.	Fastener	Torque			Remarks
		N·m	kgf·m	ft·lb	
1	Engine Oil Drain Bolt	20	2.0	15	
2	Oil Filter	31	3.2	23	G, R
3	Oil Filter Pipe	35	3.6	26	L
4	Oil Pan Bolts	10	1.0	89 in·lb	
5	Oil Pressure Relief Valve	15	1.5	11	L
6	Oil Pressure Switch	15	1.5	11	SS
7	Oil Pressure Switch Terminal Bolt	1.5	0.15	13 in·lb	G
8	Oil Pump Gear Bolts	10	1.0	89 in·lb	L
9	Oil Passage Plugs	20	2.0	15	L
10	Oil Pump Cover Bolts	10	1.0	89 in·lb	
11	Oil Cooler/Oil Filter Case Mounting Bolts	20	2.0	15	L
12	Oil Cooler Mounting Bolts	20	2.0	15	L

EO: Apply engine oil.

G: Apply grease.

L: Apply a non-permanent locking agent.

MO: Apply molybdenum disulfide oil solution.

(mixture of the engine oil and molybdenum disulfide grease in a weight ratio 10 : 1)

R: Replacement Parts

SS: Apply silicone sealant (Kawasaki Bond: 92104-0004).

www.zxforums.com

Engine Oil Flow Chart

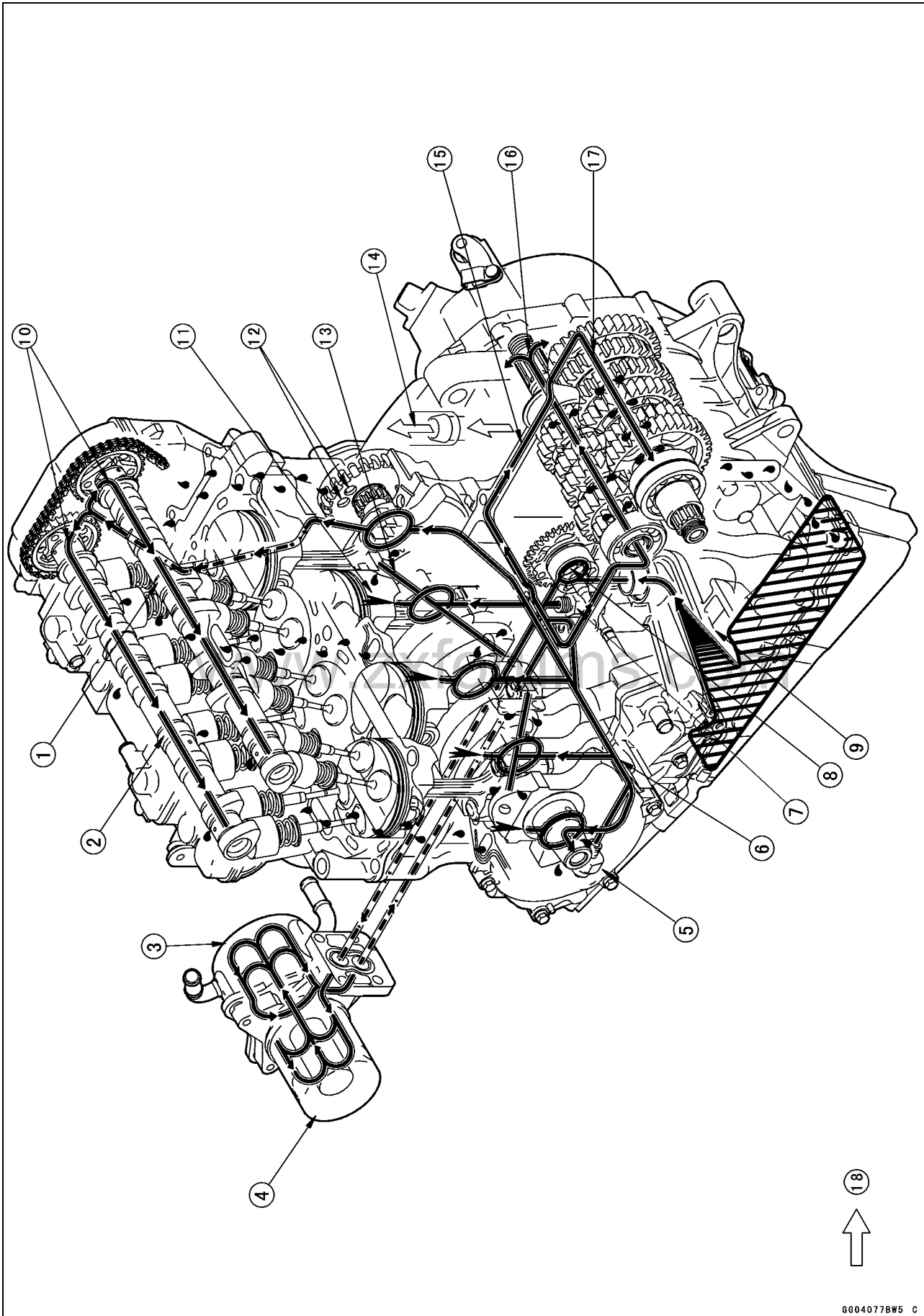

600407BW5 C

Engine Oil Flow Chart

1. Inlet Camshaft
2. Exhaust Camshaft
3. Oil Cooler
4. Oil Filter
5. Oil Pressure Switch
6. Main Oil Passage
7. Relief Valve
8. Oil Pump
9. Oil Screen
10. Camshaft Oil Passage
11. Oil Jet
12. Starter Clutch Oil Passage
13. Crankshaft Oil Passage
14. To Air Cleaner
15. Crankcase Oil Passage
16. Drive Shaft Oil Passage
17. Output Shaft Oil Passage
18. Blowby Gas

www.zxforums.com

7-6 ENGINE LUBRICATION SYSTEM

Specifications

Item	Standard
Engine Oil	
Type	API SE, SF or SG API SH, SJ or SL with JASO MA
Viscosity	SAE 10W-40
Capacity	3.2 L (3.4 US qt) (when filter is not removed) 3.7 L (3.9 US qt) (when filter is removed) 4.0 L (4.2 US qt) (when engine is completely dry)
Level	Between upper and lower level lines
Oil Pressure Measurement	
Oil Pressure	150 ~ 230 kPa (1.5 ~ 2.4 kgf/cm ² , 22 ~ 33 psi) at 4 000 r/min (rpm), Oil Temperature 90°C (194°F)

www.zxforums.com

Special Tools and Sealant

Oil Pressure Gauge, 10 kgf/cm²:
57001-164

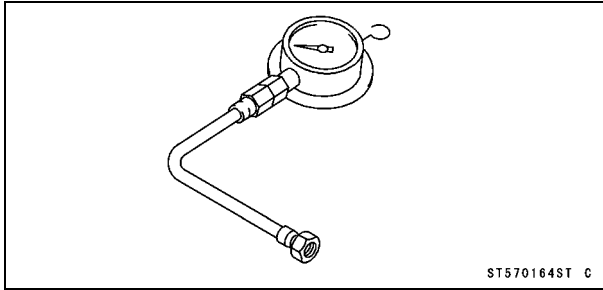

Gear Holder:
57001-1599

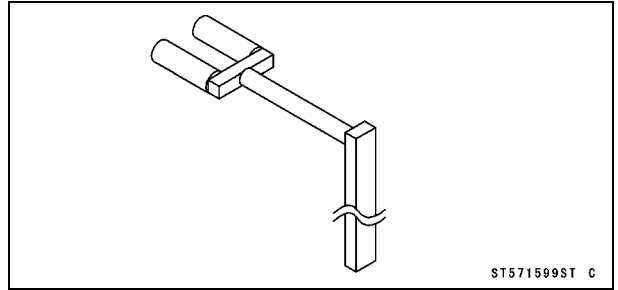

Oil Pressure Gauge Adapter, PT3/8:
57001-1233

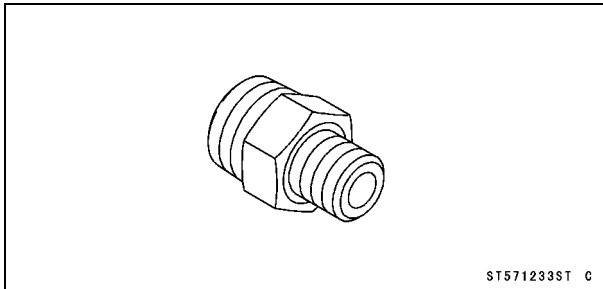

Kawasaki Bond (Silicone Sealant):
92104-0004

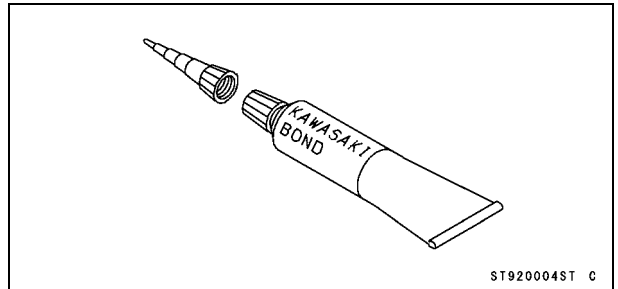

Oil Filter Wrench:
57001-1249

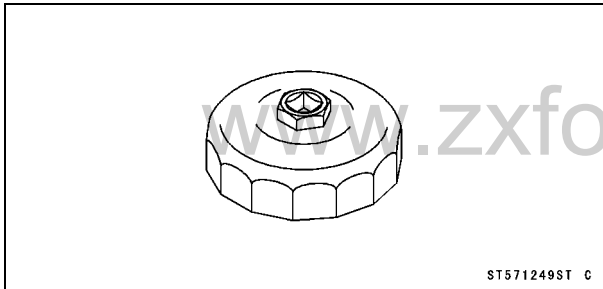

Engine Oil and Oil Filter

⚠ WARNING

Motorcycle operation with insufficient, deteriorated, or contaminated engine oil will cause accelerated wear and may result in engine or transmission seizure, accident, and injury.

Oil Level Inspection

- Check that the engine oil level is between the upper [A] and lower [B] levels in the gauge.

NOTE

- Situate the motorcycle so that it is perpendicular to the ground.
- If the motorcycle has just been used, wait several minutes for all the oil to drain down.
- If the oil has just been changed, start the engine and run it for several minutes at idle speed. This fills the oil filter with oil. Stop the engine, then wait several minutes until the oil settles.

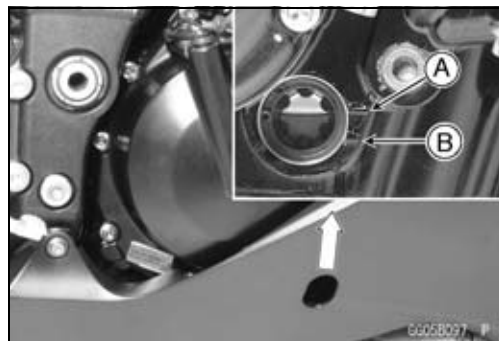

CAUTION

Racing the engine before the oil reaches every part can cause engine seizure.

If the engine oil gets extremely low or if the oil pump or oil passages clog up or otherwise do not function properly, the oil pressure warning light will light. If this light stays on when the engine is running above idle speed, stop the engine immediately and find the cause.

Engine Oil Change

- Refer to the Engine Oil Change in the Periodic Maintenance chapter (see Engine Oil Change in the Periodic Maintenance chapter).

Oil Filter Replacement

- Refer to the Oil Filter Replacement in the Periodic Maintenance chapter (see Oil Filter Replacement in the Periodic Maintenance chapter).

Oil Pan

Oil Pan Removal

- Drain the engine oil (see Engine Oil Change in the Periodic Maintenance chapter).
- Remove:
 - Front Exhaust Pipe (see Front Exhaust Pipe Removal in the Engine Top End chapter)
 - Oil Pan Bolts [A]
 - Clamps [B]
 - Oil Pan [C]

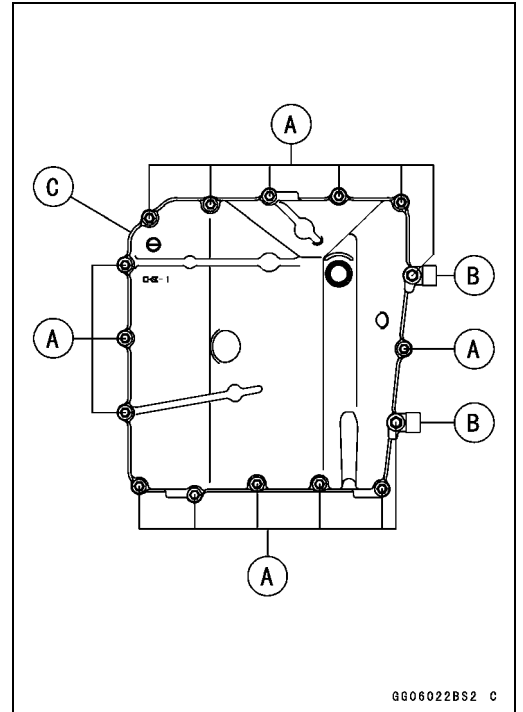

Oil Pan Installation

- Replace the oil pan gasket [A] with a new one.
- Install the clamps [B] as shown.
 - Rear View [C]
- Tighten:
 - Torque - Oil Pan Bolts: 10 N·m (1.0 kgf·m, 89 in·lb)

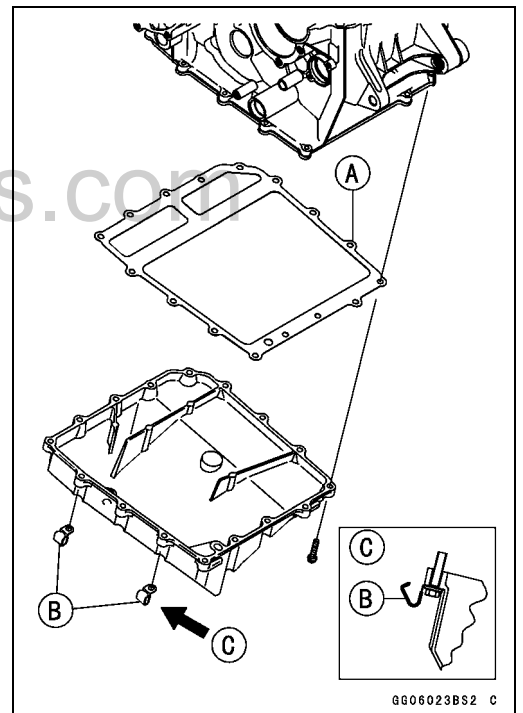

Oil Pressure Relief Valve

Oil Pressure Relief Valve Removal

- Remove:
 - Oil Pan (see Oil Pan Removal)
 - Oil Screen [A]

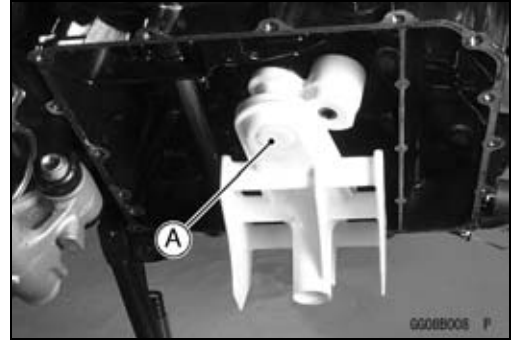

- Remove the oil pressure relief valve [A].

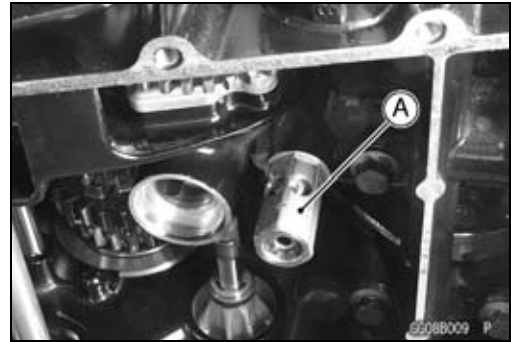

Oil Pressure Relief Valve Installation

- Apply a non-permanent locking agent to the threads of the oil pressure relief valve [A], and tighten it.

CAUTION

Do not apply too much non-permanent locking agent to the threads. This may block the oil passage.

Torque - Oil Pressure Relief Valve: 15 N·m (1.5 kgf·m, 11 ft·lb)

- Clean the oil screen [B].
- Install the O-ring [C] and damper [D] to the oil screen.
- Install the oil screen so that the crankcase rib [E] and relief valve fits the oil screen.
- Install the oil pan (see Oil Pan Installation).

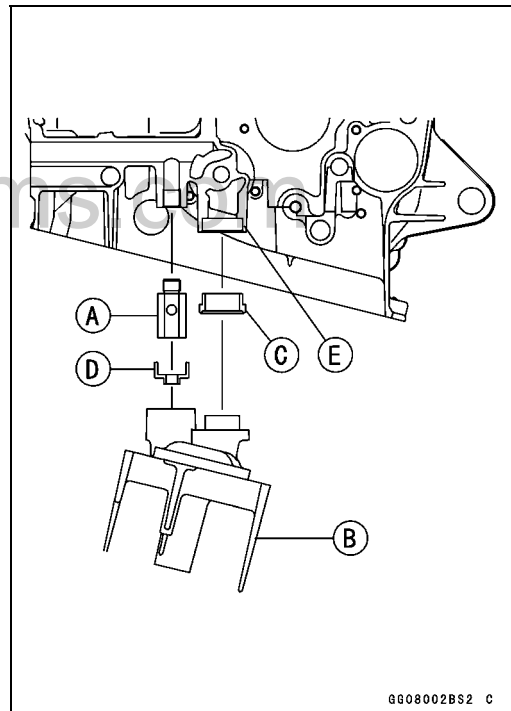

Oil Pressure Relief Valve

Oil Pressure Relief Valve Inspection

- Remove the oil pressure relief valve (see Oil Pressure Relief Valve Removal).
- Check to see if the valve [A] slides smoothly when pushing it in with a wooden or other soft rod, and see if it comes back to its seat by spring [B] pressure.

NOTE

○ *Inspect the valve in its assembled state. Disassembly and assembly may change the valve performance.*

- ★ If any rough spots are found during above inspection, wash the valve clean with a high-flash point solvent and blow out any foreign particles that may be in the valve with compressed air.

⚠ WARNING

Clean the oil pressure relief valve in a well-ventilated area, and take care that there is no spark or flame anywhere near the working area. Because of the danger of highly flammable liquids, do not use gasoline or low-flash point solvent.

- ★ If cleaning does not solve the problem, replace the oil pressure relief valve as an assembly. The oil pressure relief valve is precision made with no allowance for replacement of individual parts.

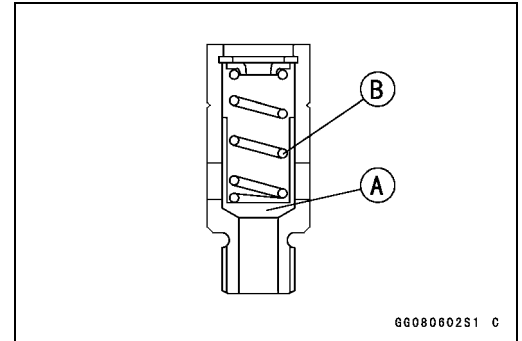

www.zxforums.com

Oil Pump

Oil Pump Removal

- Remove:
 - Oil Pump Gear (see Oil Pump Gear Removal)
 - Oil Pump Cover Bolts [A]

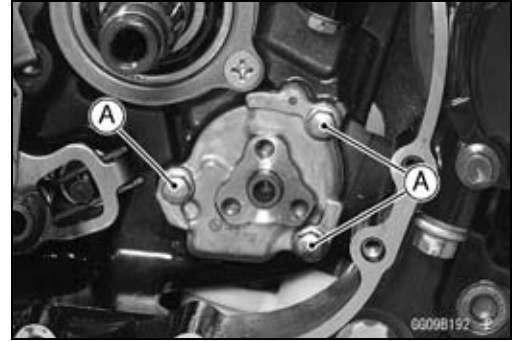

- Remove the oil pump cover [A] with oil pump gear shaft [B].
- Stuff the cloth [C] on the hole of the crankcase so that pin [D] close not drop into the crankcase bottom.
- Remove the outer rotor [E] and inner rotor [F].

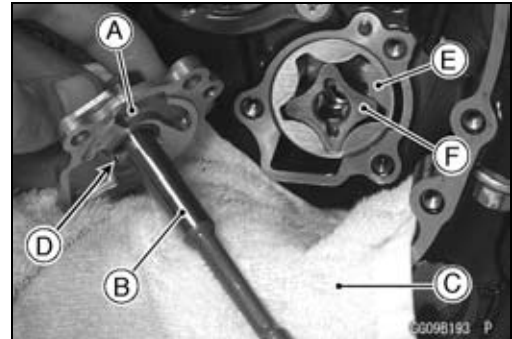

Oil Pump Installation

- Apply molybdenum disulfide oil solution to the journal portions [A] on the oil pump gear shaft [B] and crankcase [C].

www.zxforums.com

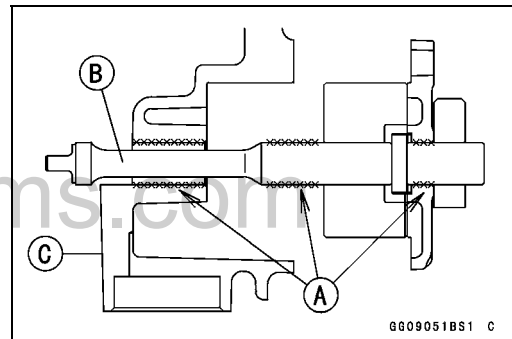

- Install the following to the oil pump gear shaft [A].
 - Oil Pump Cover [B]
 - Washer [C]

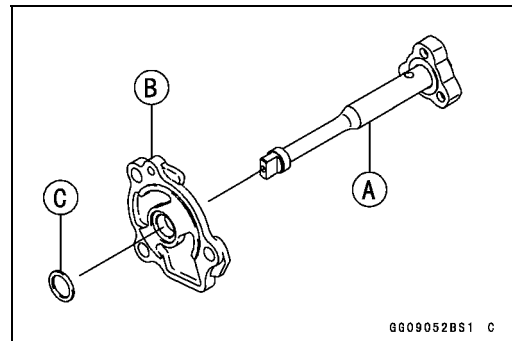

- Install the pin [A].
- Fit the pin into the slot [B] of the inner rotor [C].
- Apply engine oil to the inner rotor.

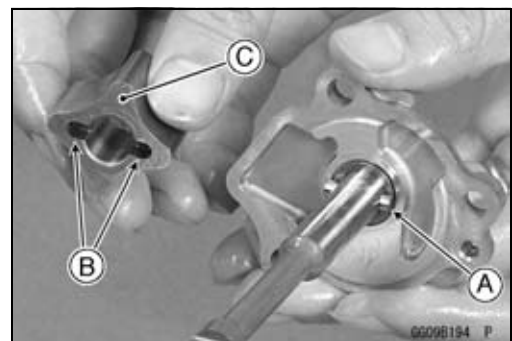

Oil Pump

- Install the outer rotor [A] on the inner rotor.
- Apply engine oil to the outer rotor.
- Install the dowel pin [B].
- Fit the pin of the oil pump cover into the hole [C] in the crankcase.

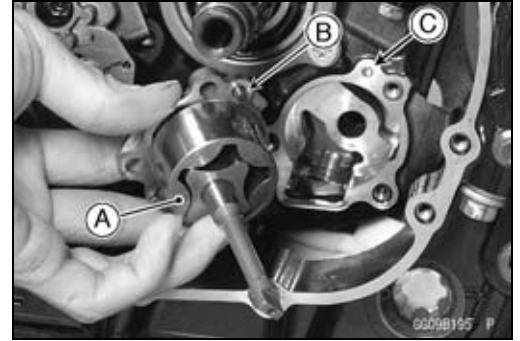

- Turn the oil pump gear shaft [A] so that the projection [B] in its shaft fits onto the slot [C] of the impeller shaft.

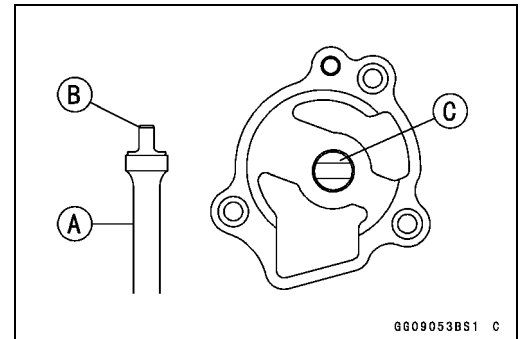

- Tighten the oil pump cover bolts.
Torque - Oil Pump Cover Bolts: 10 N·m (1.0 kgf·m, 89 in·lb)
- Install the oil pump gear (see Oil Pump Gear Installation).

Oil Pump Gear Removal

- Remove the clutch (see Clutch Removal in the Clutch chapter).
- Hold the oil pump gear [A] steady with the gear holder [B], and remove the bolts [C].

Special Tool - Gear Holder: 57001-1599

- Remove the oil pump gear.

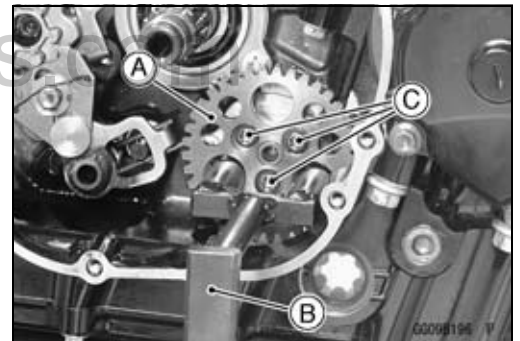

Oil Pump Gear Installation

- Install the oil pump gear [A] direction as shown.

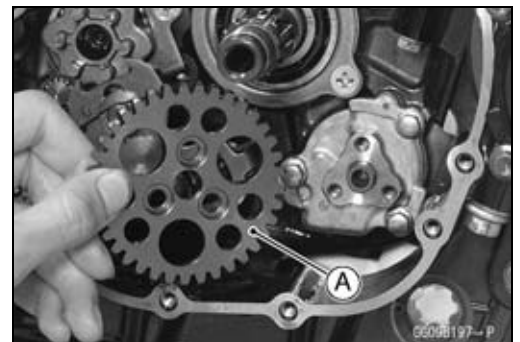

Oil Pump

- Apply a non-permanent locking agent to the threads of the oil pump gear bolts [A].
- Hold the oil pump gear [B] steady with the gear holder [C], and tighten the bolts.

Special Tool - Gear Holder: 57001-1599

Torque - Oil Pump Gear Bolts: 10 N·m (1.0 kgf·m, 89 in·lb)

- Install the clutch (see Clutch Installation in the Clutch chapter).

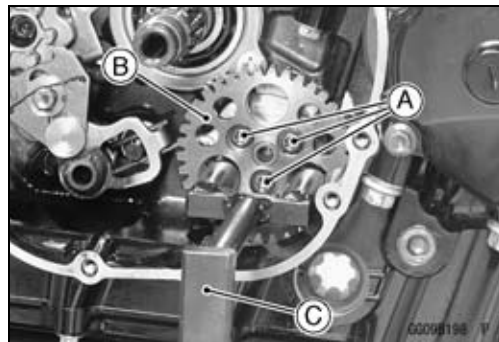

Oil Cooler

Oil Cooler Removal

- Drain:
 - Coolant (see Coolant Change in the Periodic Maintenance chapter)
 - Engine Oil (see Engine Oil Change in the Periodic Maintenance chapter)
- Remove:
 - Water Hoses [A]
 - Oil Cooler Mounting Bolts [B]
 - Oil Cooler [C]

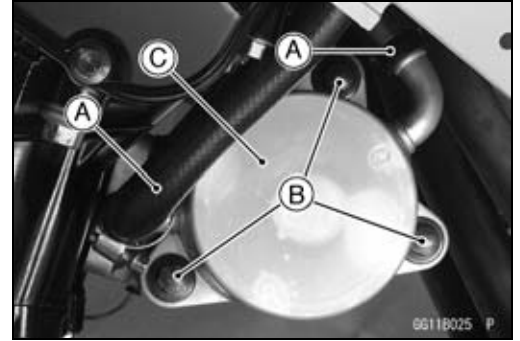

Oil Cooler Installation

- Replace the O-ring [A] with a new one.
- Apply grease to the new O-ring.



- Install the oil cooler [A].
 - Torque - Oil Cooler Mounting Bolts: 20 N·m (2.0 kgf·m, 15 ft·lb)**
- Install the water hoses [B] as shown.
 - Front View [C]
- Tighten:
 - Torque - Water Hose Clamp Screw: 2.0 N·m (0.20 kgf·m, 18 in·lb)**
- Pour:
 - Engine Oil (see Oil Change in the Periodic Maintenance chapter)
 - Coolant (see Coolant Change in the Periodic Maintenance chapter)

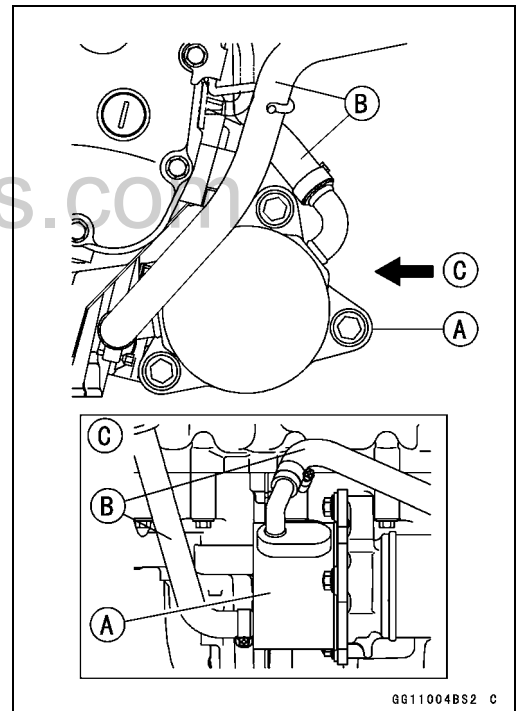

Oil Cooler/Oil Filter Case Removal

- Remove:
 - Oil Filter (see Oil Filter Replacement in the Periodic Maintenance chapter)
 - Oil Cooler (see Oil Cooler Removal)
 - Bolts [A]
 - Oil Cooler/Oil Filter Case [B]
- Remove the oil filter pipe [C] as necessary.

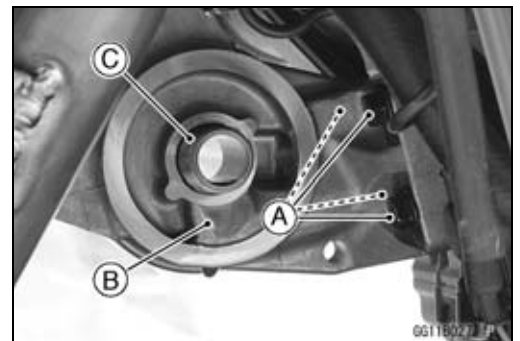

Oil Cooler

Oil Cooler/Oil Filter Case Installation

- Replace the O-ring [A] with a new one.
- Apply grease to the new O-ring.
- ★ If the oil filter pipe [B] was removed, install it.
- Apply a non-permanent locking agent to the threads of the oil filter pipe, and tighten it.

Torque - Oil Filter Pipe: 35 N·m (3.6 kgf·m, 26 ft·lb)

- Apply non-permanent locking agent to the threads of the oil cooler/oil filter case mounting bolts, and tighten it.

Torque - Oil Cooler/Oil Filter Case Mounting Bolts: 20 N·m (2.0 kgf·m, 15 ft·lb)

- Install:
 - Oil Cooler (see Oil Cooler Installation)
 - Oil Filter (see Oil Filter Replacement in the Periodic Maintenance chapter)

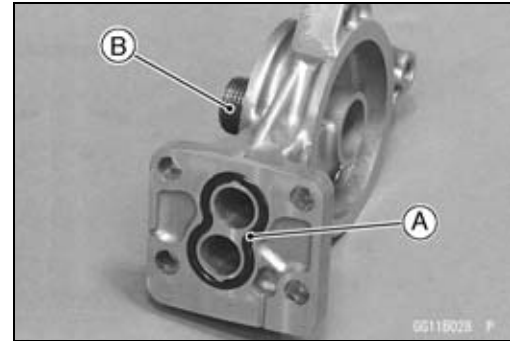

Oil Pressure Measurement

Oil Pressure Measurement

- Remove:
 - Lower Fairings (see Lower Fairing Removal in the Frame chapter)
 - Oil Passage Plug [A]

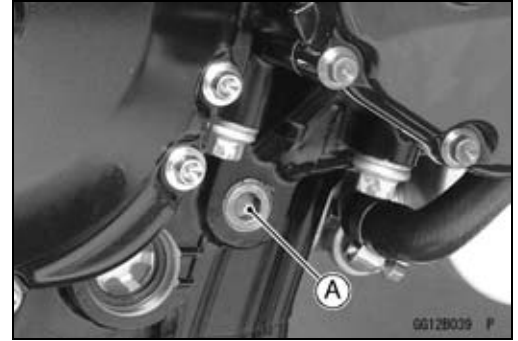

- Attach the adapter [A] and gauge [B] to the plug hole.
 - Special Tools - Oil Pressure Gauge, 10 kgf/cm²: 57001-164**
 - Oil Pressure Gauge Adapter, PT3/8: 57001-1233**



- Start the engine and warm up the engine.
- Run the engine at the specified speed, and read the oil pressure gauge.

Oil Pressure

Standard: 150 ~ 230 kPa (1.5 ~ 2.4 kgf/cm², 22 ~ 33 psi) at 4 000 r/min (rpm), oil temperature 90°C (194°F)

- ★ If the oil pressure is much lower than the standard, check the oil pump, relief valve, and/or crankshaft bearing insert wear immediately.
- ★ If the reading is much higher than the standard, check the oil passages for clogging.
- Stop the engine.
- Remove the oil pressure gauge and adapter.

⚠ WARNING

Take care against burns from hot engine oil that will drain through the oil passage when the gauge adapter is removed.

- Apply a non-permanent locking agent to the oil passage plug, and install it.
- Torque - Oil Passage Plugs: 20 N·m (2.0 kgf·m, 15 ft·lb)**

Oil Pressure Switch

Oil Pressure Switch Removal

- Drain the engine oil (see Engine Oil Change in the Periodic Maintenance chapter).
- Remove the left lower fairing (see Lower Fairing Removal in the Frame chapter).
- Slide out the rubber boot [A].
- Loosen the oil pressure switch terminal bolt [B], and remove the switch lead [C].
- Remove the oil pressure switch [D].

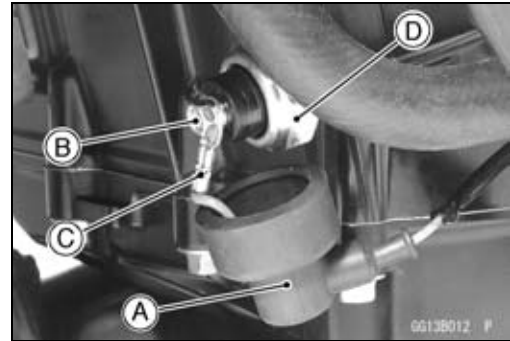

Oil Pressure Switch Installation

- Apply silicone sealant to the threads of the oil pressure switch [A] and tighten it.

Sealant - Kawasaki Bond (Silicone Sealant): 92104-0004

Torque - Oil Pressure Switch: 15 N·m (1.5 kgf·m, 11 ft·lb)

- Install the switch lead [B] direction downward.
- Apply grease to the switch terminal [C], and tighten the bolt.

Torque - Oil Pressure Switch Terminal Bolt: 1.5 N·m (0.15 kgf·m, 13 in·lb)

- Slide back the rubber boot to the original position.

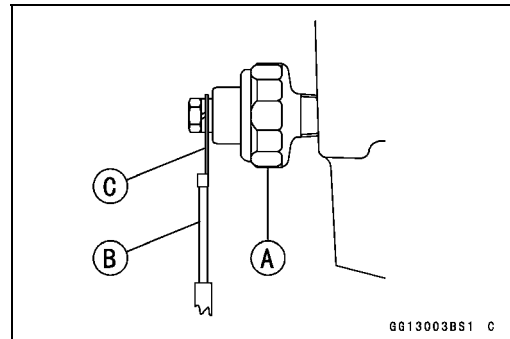

Engine Removal/Installation

Table of Contents

Exploded View	8-2
Special Tool	8-4
Engine Removal/Installation	8-5
Engine Removal.....	8-5
Engine Installation	8-8

www.zxforums.com

Exploded View

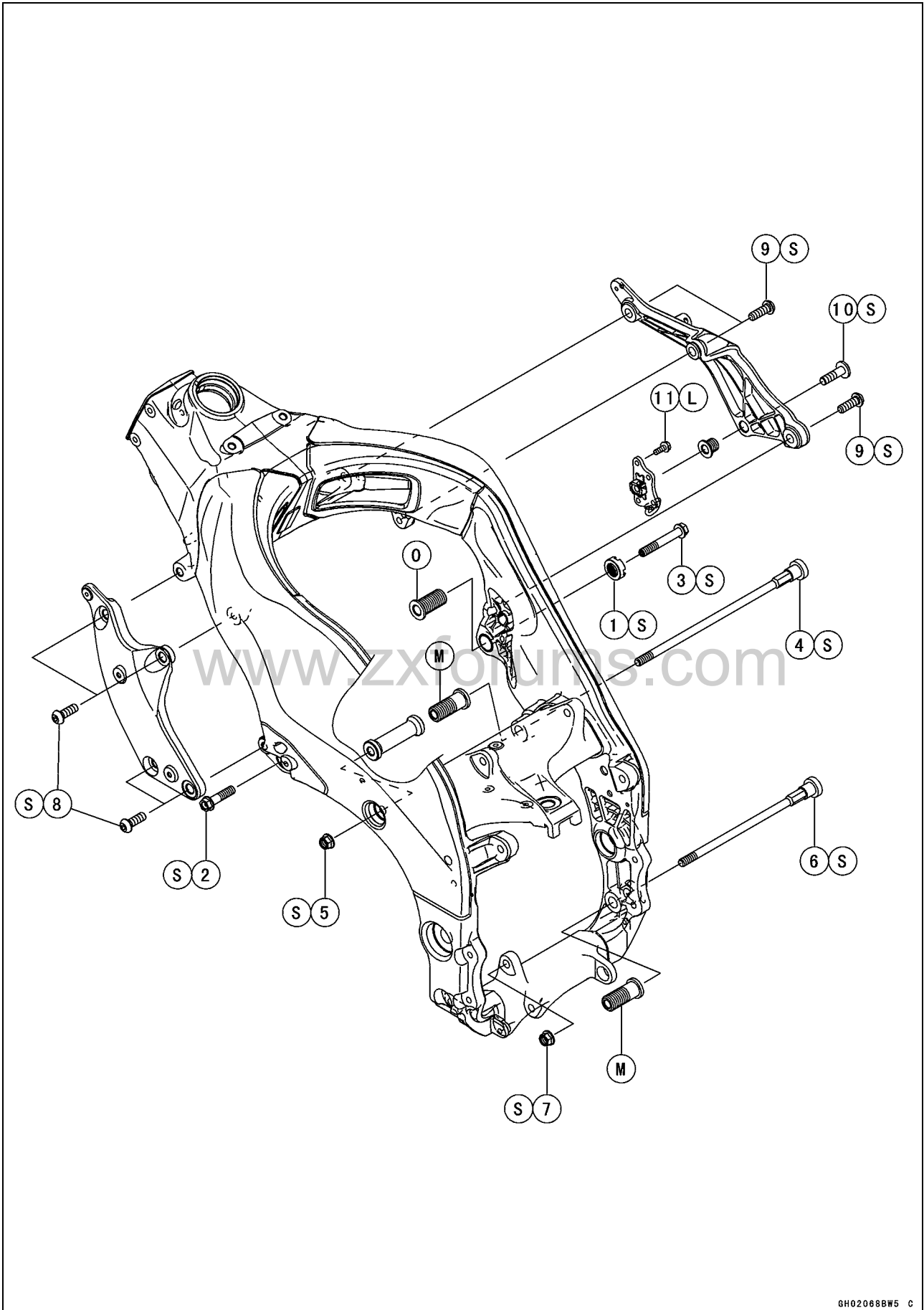

GH02068BW5 C

Exploded View

No.	Fastener	Torque			Remarks
		N·m	kgf·m	ft·lb	
1	Adjusting Collar Locknut	49	5.0	36	S
2	Lef Front Engine Mounting Bolt (M10, L = 42)	44	4.5	32	S
3	Right Front Engine Mounting Bolt (M10, L = 67)	44	4.5	32	S
4	Middle Engine Mounting Bolt	9.8	1.0	87 in·lb	S
5	Middle Engine Mounting Nut	44	4.5	32	S
6	Lower Engine Mounting Bolt	9.8	1.0	87 in·lb	S
7	Lower Engine Mounting Nut	44	4.5	32	S
8	Left Engine Bracket Bolts (M10, L = 30)	44	4.5	32	S
9	Right Engine Bracket Bolts (M10, L = 30)	44	4.5	32	S
10	Right Engine Bracket Bolt (M10, L = 35)	44	4.5	32	S
11	Right Engine Bracket Bolts (Cylinder Head Side)	10	1.0	89 in·lb	L

L: Apply a non-permanent locking agent.

M: Apply molybdenum disulfide grease.

O: Apply 2-stroke oil.

S: Follow the specified tightening sequence.

www.zxforums.com

Special Tool

**Engine Mount Nut Wrench:
57001-1450**

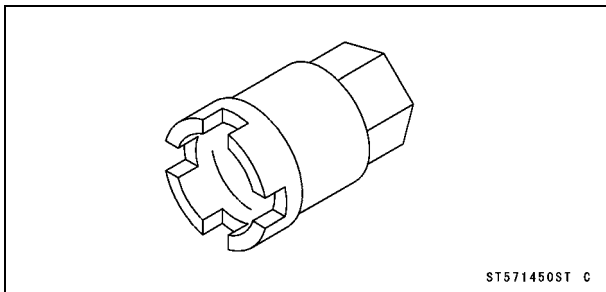

www.zxforums.com

Engine Removal/Installation

Engine Removal

- Support the rear part of the swingarm with a stand.
- Squeeze the brake lever slowly and hold it with a band [A].

⚠ WARNING

Be sure to hold the front brake when removing the engine, or the motorcycle may fall over. It could cause an accident and injury.

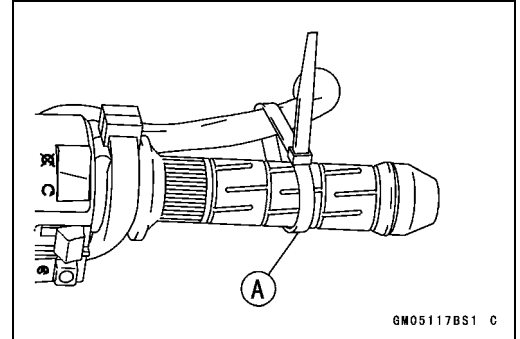

CAUTION

Be sure to hold the front brake when removing the engine, or the motorcycle may fall over. The engine or the motorcycle could be damaged.

- Drain:
 - Engine Oil (see Engine Oil Change in the Periodic Maintenance chapter)
 - Coolant (see Coolant Change in the Periodic Maintenance chapter)
- Remove:
 - Middle Fairings (see Middle Fairing Removal in the Frame chapter)
 - Coolant Reserve Tank (see Coolant Reserve Tank Removal in the Cooling System chapter)
 - Fuel Tank (see Fuel Tank Removal in the Fuel System (DFI) chapter)
 - Air Cleaner Housing (see Air Cleaner Housing Removal in the Fuel System (DFI) chapter)
 - Throttle Body Assy (see Throttle Body Assy Removal in the Fuel System (DFI) chapter)
 - Clutch Cable Lower End (see Cable Removal in the Clutch chapter)
 - Radiator (see Radiator and Radiator Fan Removal in the Cooling System chapter)
 - Front Exhaust Pipe (see Front Exhaust Pipe Removal in the Engine Top End chapter)
 - Shift Lever (see Shift Pedal Removal in the Crankshaft/Transmission chapter)
 - Engine Sprocket (see Engine Sprocket Removal in the Final Drive chapter)
- Pull off the connectors from the engine and free the wiring from the clamps.
- Disconnect:
 - Camshaft Position Sensor Connector [A]
 - Harness Joint Connector [B]
 - Immobilizer Amplifier Connector (Immobilizer Models)

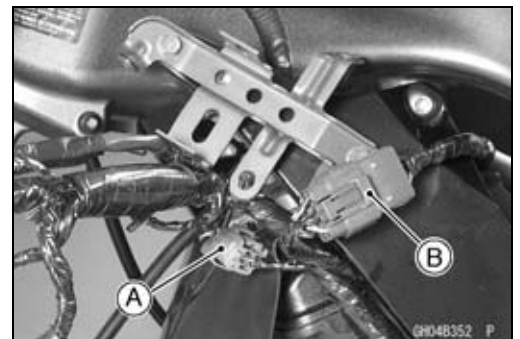

Engine Removal/Installation

- Disconnect the sidestand switch lead connector [A].



- Remove:
Gear Position Switch Lead Connector [A]
Alternator Lead Connector [B]

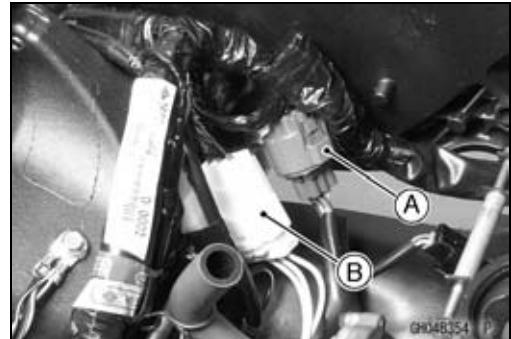

- Remove:
Engine Ground Cable Terminal Bolt [A]
Starter Motor Cable [B]

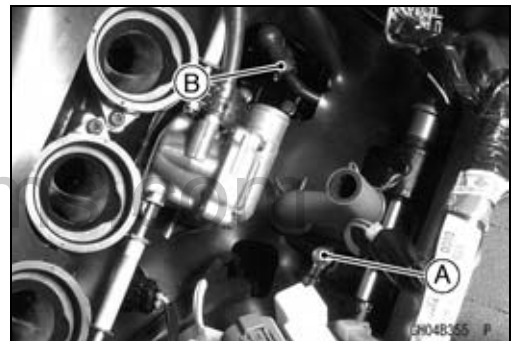

- Support the engine with a suitable stand [A].
○ Put a plank [B] onto the suitable stand for engine balance.

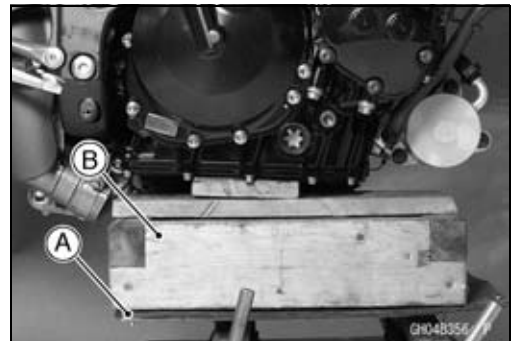

- Remove:
Left Upper Inner Fairing Bracket Bolts [A]
Left Upper Inner Fairing Bracket [B]

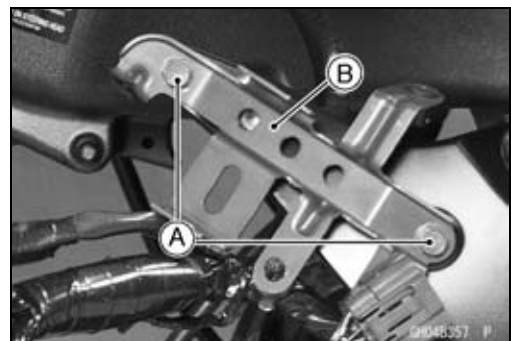

Engine Removal/Installation

- Remove:
 - Left Engine Bracket Bolts [A]
 - Left Engine Bracket [B]

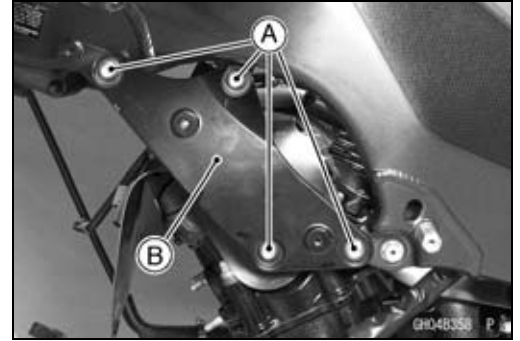

- Remove:
 - Right Upper Inner Fairing Bracket Bolts [A]
 - Right Upper Inner Fairing Bracket [B]

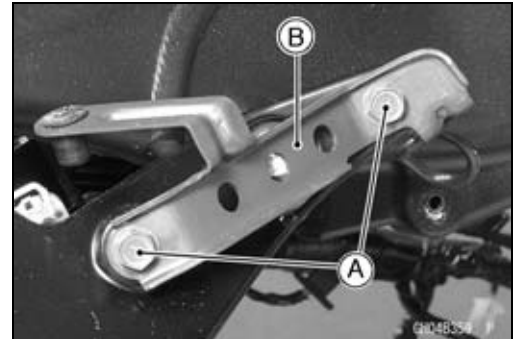

- Remove:
 - Right Engine Bracket Bolts [A]
 - Right Engine Bracket [B]

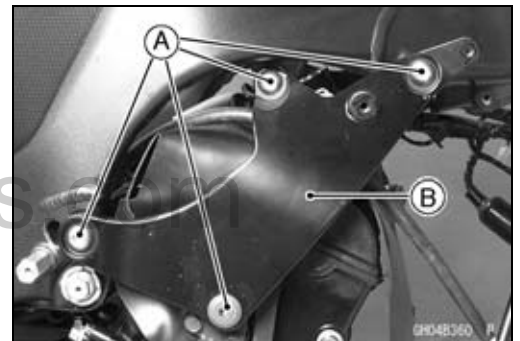

- Remove:
 - Left Front Engine Mounting Bolt [A]
 - Middle Engine Mounting Nut [B]
 - Lower Engine Mounting Nut [C]

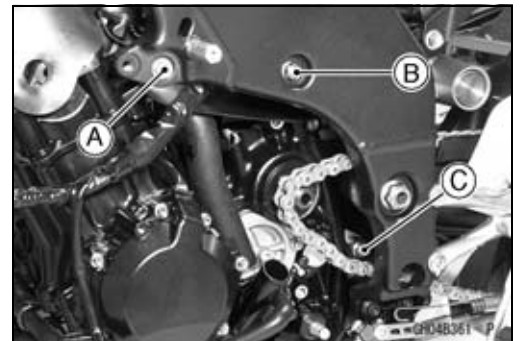

- Turn the middle [A] and lower [B] engine mounting bolts clockwise to make the gap between the adjusting collar and frame.
- Pull out the engine mounting bolts from the right side.
- Remove the collar while pulling out the middle engine mounting bolt.
- Remove the right front engine mounting bolts [C].

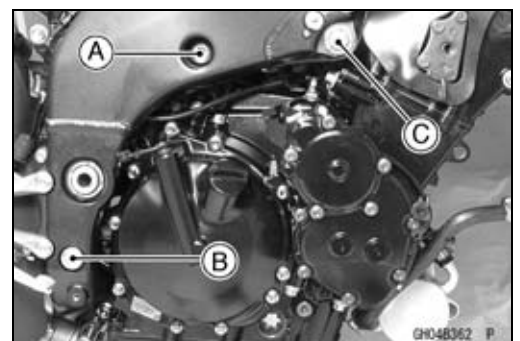

Engine Removal/Installation

- Using the nut wrench [A], loosen the locknut [B].
Special Tool - Engine Mount Nut Wrench: 57001-1450

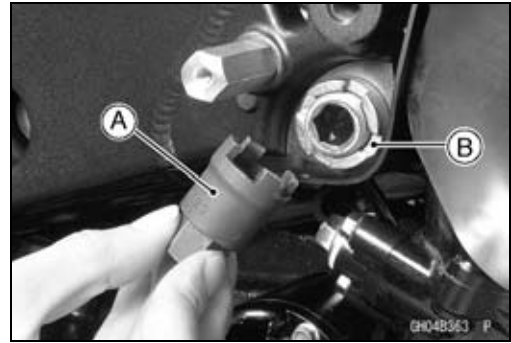

- Using the Hexagon Wrench, turn the adjusting collar [A] counterclockwise to make the gap between the engine and adjusting collar.



- Remove the drive chain [A] from the output shaft [B].
- Using the stand, take out the engine.

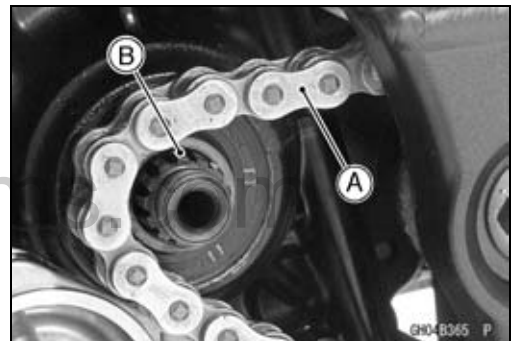

www.zxforum

Engine Installation

- Support the engine with a suitable stand.
- Put a plank onto the suitable stand for engine balance.
- Install the heat insulation rubber plate onto the engine as shown.

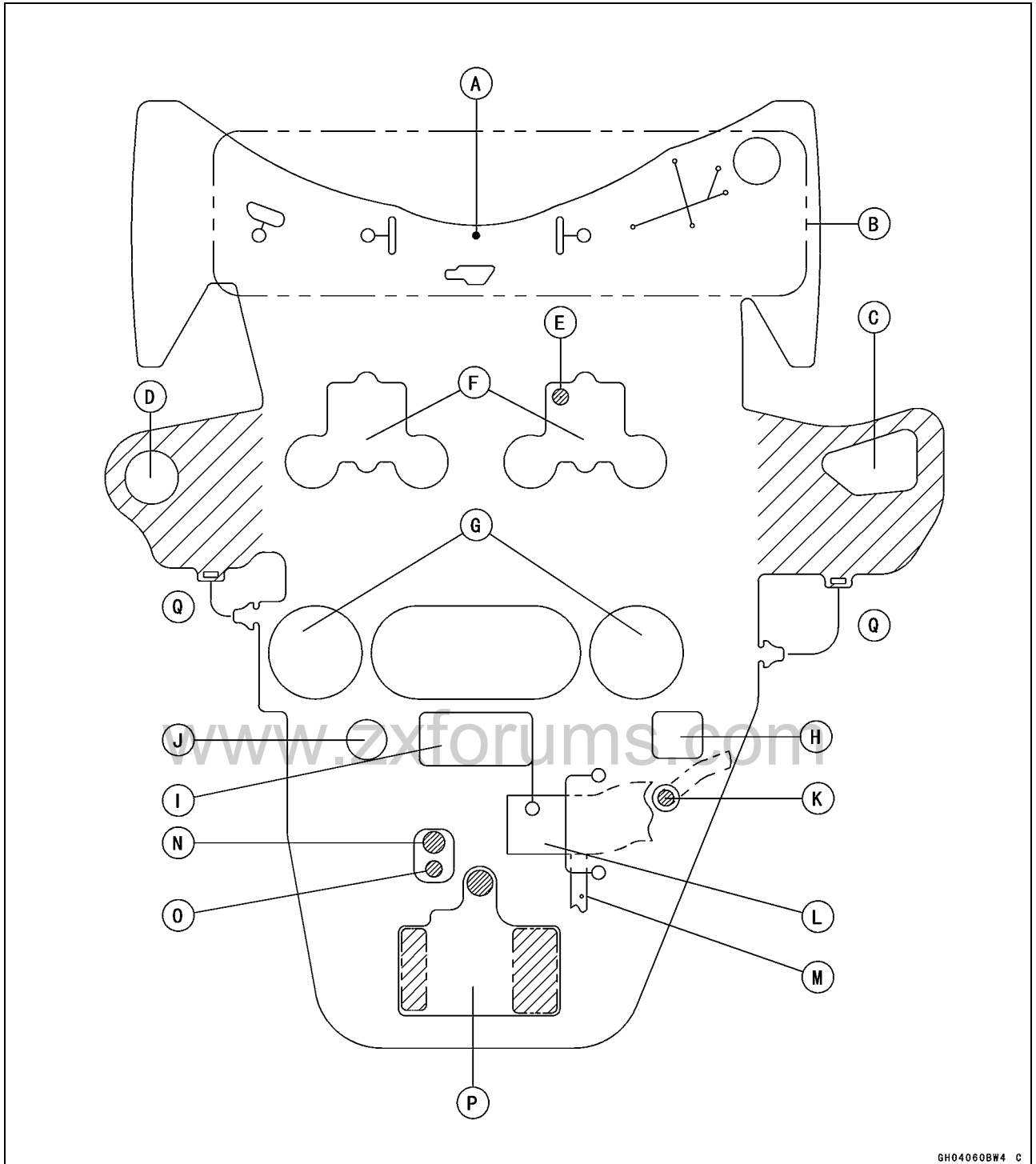
Engine Removal/Installation

GH04060BW4 C

- A: White Mark
 B: To Radiator
 C: To Right Engine Bracket (Cylinder Head Side)
 D: Through the left engine bracket bolt.
 E: To Camshaft Position Sensor Lead
 F: To Air Suction Valve Cover and Stick Coil
 G: To Throttle Body Assy Holder
 H: Right Front Engine Mount
 I: To Thermostat Case
 J: To Water Temperature Sensor

- K: Crankshaft Sensor Lead
 L: Through the water hose under the heat insulation rubber plate
 M: Through the starter motor cable under the water hose.
 N: Gear Position Switch/Water Temperature Sensor Lead (Harness).
 O: Alternator Lead
 P: To Breather Tube and Middle Engine Mount
 Q: After installation, set the projection in the hole

Engine Removal/Installation

- Install the engine mounting bolts and nuts, following the specified installing sequence.
- Apply molybdenum disulfide grease to the threads of the adjusting collars [A].
- Apply 2-stroke oil to the threads of the adjusting collar [B].
- First, install the adjusting collars [A] [B] to crankcase and frame.
- Crankcase [C]
- Frame [D]

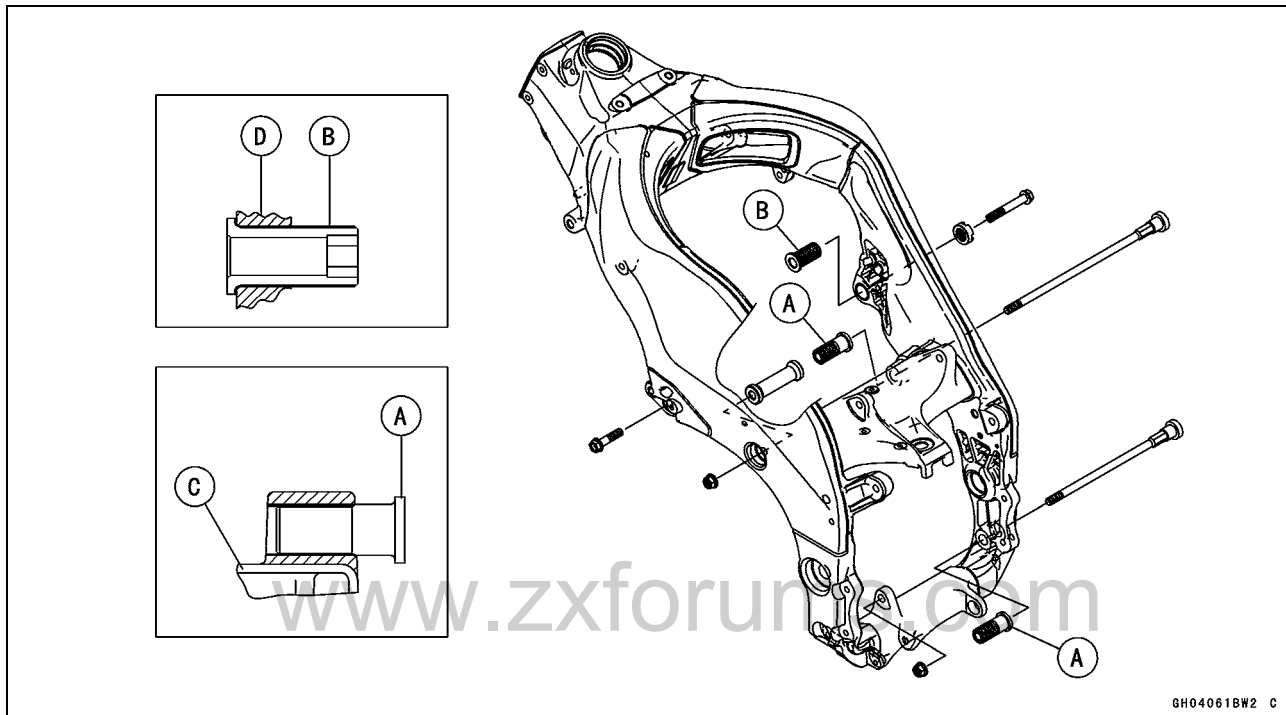

- Second, hang the drive chain over the output shaft just before mounting the engine into its final position in the frame.
- Third, install the bolts [A] [B] [C] [D] temporarily, and tighten the bolt [C].
- When installing the middle engine mounting bolt [B], install the collar [E] between frame and crankcase.
- Torque - Left Front Engine Mounting Bolt: 44 N·m (4.5 kgf·m, 32 ft·lb)**
- Fourth, Insert the lower [A] and middle [B] engine mounting bolts to the adjusting collars [F], and tighten the bolts counterclockwise.

NOTE

- Tighten the bolts until the clearance [G] between the engine and collar come to 0 mm (0 in.).

- Torque - Middle Engine Mounting Bolt: 9.8 N·m (1.0 kgf·m, 87 in·lb)**
- Lower Engine Mounting Bolt: 9.8 N·m (1.0 kgf·m, 87 in·lb)**

Engine Removal/Installation

- Fifth, tighten the middle engine mounting nut [H], and then lower engine mounting nut [I].

Torque - Middle Engine Mounting Nut: 44 N·m (4.5 kgf·m, 32 ft·lb)

Lower Engine Mounting Nut: 44 N·m (4.5 kgf·m, 32 ft·lb)

- Sixth, remove the bolt [D] temporarily, and using the hexagon wrench, turn the adjusting collar [J] until the clearance [K] between the cylinder head and frame come to 0 mm (0 in.).

- Seventh, using the engine mount nut wrench (special tool), tighten the adjusting collar locknut [L].

Special Tool - Engine Mount Nut Wrench: 57001-1450

Torque - Adjusting Collar Locknut: 49 N·m (5.0 kgf·m, 36 ft·lb)

- Lastly, reinstall the bolt [D] and tighten it.

Torque - Right Front Engine Mounting Bolt: 44 N·m (4.5 kgf·m, 32 ft·lb)

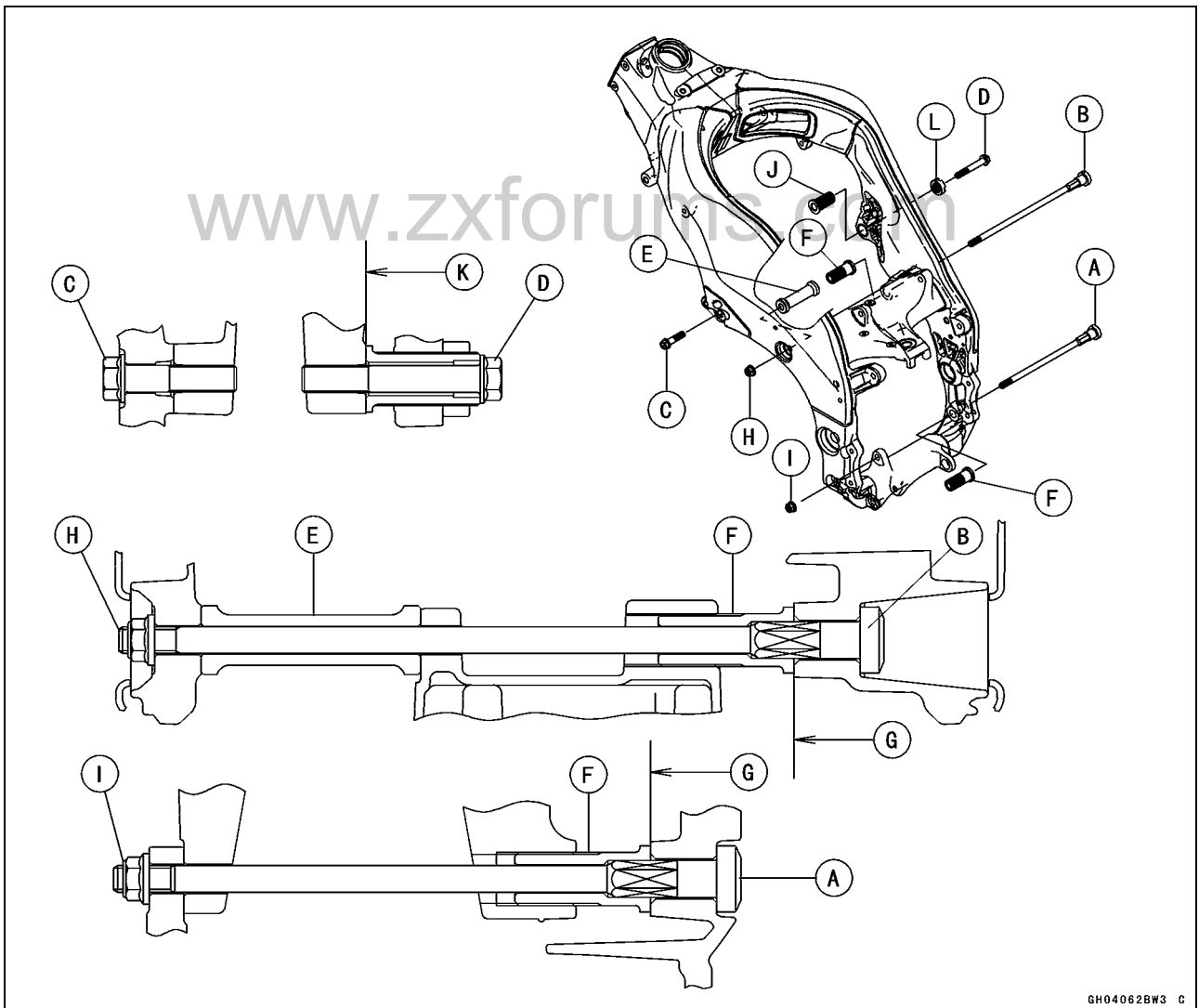

GH04062BW3 C

Engine Removal/Installation

- Install the left [A] and right [B] engine bracket, following the specified installing sequence.
- First, install the adjusting collar [C] to the right engine bracket [B].
- Second, install the bolts [D] [E] [F] [G] temporarily as shown sequence [1 ~ 8] in the figure.
- Third, tighten the bolts [D] to the tightening sequence [1 ~ 3] shown.

Torque - Left Engine Bracket Bolts: 44 N·m (4.5 kgf·m, 32 ft·lb)

- Fourth, tighten the bolts [E] to the tightening sequence [5 ~ 7] shown.

Torque - Right Engine Bracket Bolts (M10, L = 30): 44 N·m (4.5 kgf·m, 32 ft·lb)

- Fifth, tighten the bolt [F].

Torque - Left Engine Bracket Bolt: 44 N·m (4.5 kgf·m, 32 ft·lb)

- Sixth, remove the bolt [G] temporarily, and using the hexagon wrench, turn the adjusting collar [C] until the clearance [H] between the cylinder head and collar come to 0 mm (0 in.).

- Lastly, reinstall the bolt [G], and tighten it.

Torque - Right Engine Bracket Bolt (M10, L = 35): 44 N·m (4.5 kgf·m, 32 ft·lb)

www.zxforums.com

Engine Removal/Installation

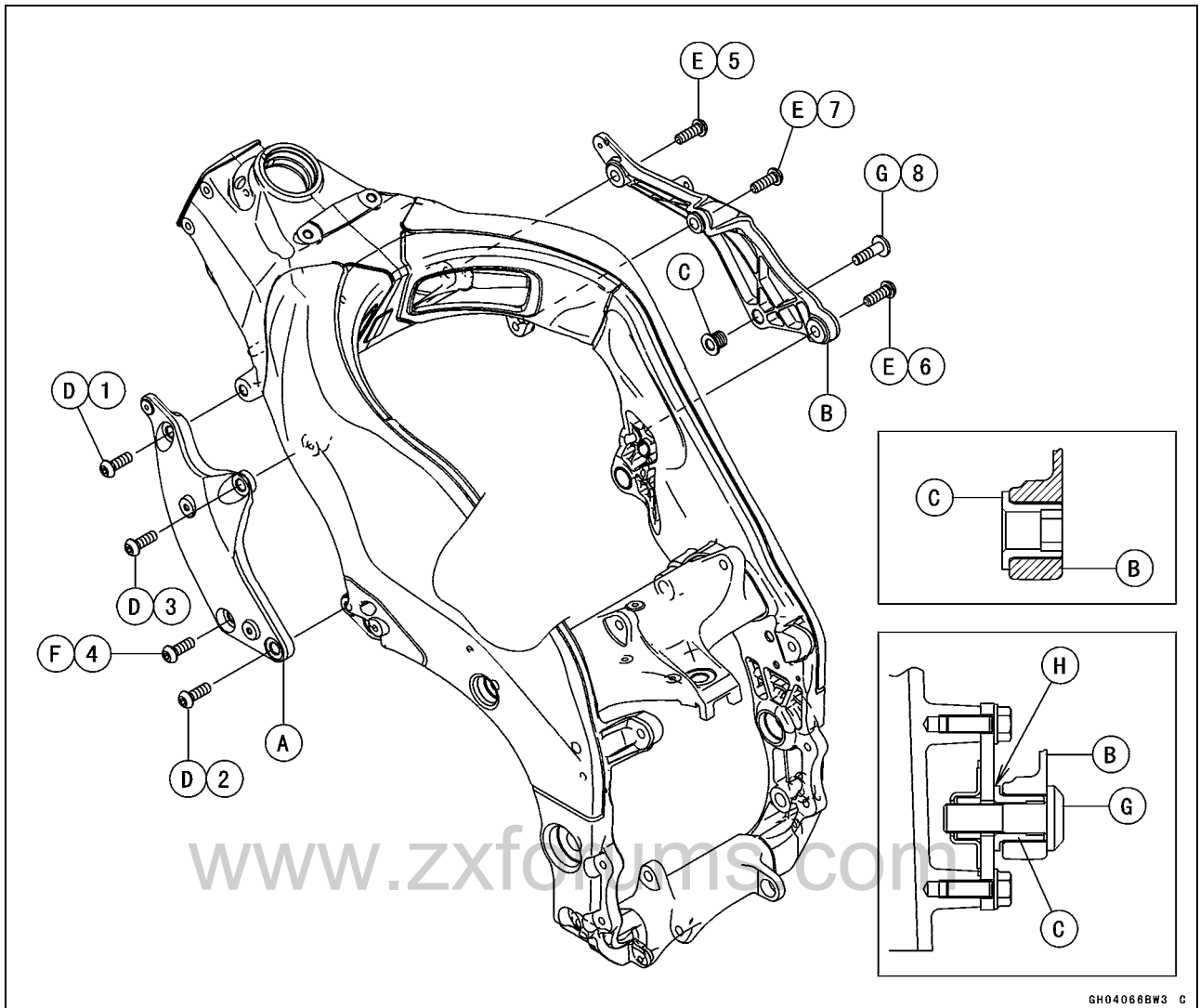

- Install the left and right upper inner fairing brackets.
- Run the leads, cable and hoses correctly (see Cable, Wire and Hose Routing section in Appendix chapter).
- Install the removed parts (see appropriate chapters).
- Adjust:
 - Throttle Cables (see Throttle Control System Inspection in the Periodic Maintenance chapter)
 - Clutch Cable (see Clutch Operation Inspection in the Periodic Maintenance chapter)
 - Drive Chain (see Drive Chain Slack Inspection in the Periodic Maintenance chapter)
- Fill the engine with engine oil (see Engine Oil Change in the Periodic Maintenance chapter).
- Fill the engine with coolant and bleed the air from the cooling system (see Coolant Change in the Periodic Maintenance chapter).

www.zxforums.com

Crankshaft/Transmission

Table of Contents

Exploded View	9-2
Specifications	9-6
Special Tools and Sealants	9-9
Crankcase Splitting.....	9-10
Crankcase Splitting	9-10
Crankcase Assembly	9-11
Crankshaft and Connecting Rods.....	9-16
Crankshaft Removal	9-16
Crankshaft Installation	9-16
Connecting Rod Removal	9-16
Connecting Rod Installation	9-17
Crankshaft/Connecting Rod Cleaning.....	9-20
Connecting Rod Bend.....	9-20
Connecting Rod Twist.....	9-21
Connecting Rod Big End Side Clearance.....	9-21
Connecting Rod Big End Bearing Insert/Crankpin Wear	9-21
Crankshaft Side Clearance.....	9-23
Crankshaft Runout.....	9-23
Crankshaft Main Bearing Insert/Journal Wear	9-24
Pistons.....	9-26
Piston Removal.....	9-26
Piston Installation.....	9-27
Cylinder Wear (Upper Crankcase).....	9-28
Piston Wear	9-28
Piston Ring, Piston Ring Groove Wear.....	9-28
Piston Ring Groove Width.....	9-29
Piston Ring Thickness	9-29
Piston Ring End Gap	9-29
Transmission	9-30
Shift Pedal Removal	9-30
Shift Pedal Installation	9-30
External Shift Mechanism Removal	9-30
External Shift Mechanism Installation	9-31
External Shift Mechanism Inspection.....	9-31
Transmission Shaft Removal	9-32
Transmission Shaft Installation	9-32
Transmission Shaft Disassembly.....	9-33
Transmission Shaft Assembly.....	9-33
Shift Drum and Fork Removal.....	9-37
Shift Drum and Fork Installation.....	9-37
Shift Drum Disassembly.....	9-37
Shift Drum Assembly	9-37
Shift Fork Bending	9-38
Shift Fork/Gear Groove Wear	9-38
Shift Fork Guide Pin/Drum Groove Wear.....	9-38
Gear Dog and Gear Dog Hole Damage.....	9-38

9-2 CRANKSHAFT/TRANSMISSION

www.zxforums.com

www.zxforums.com

www.zxforums.com

Exploded View

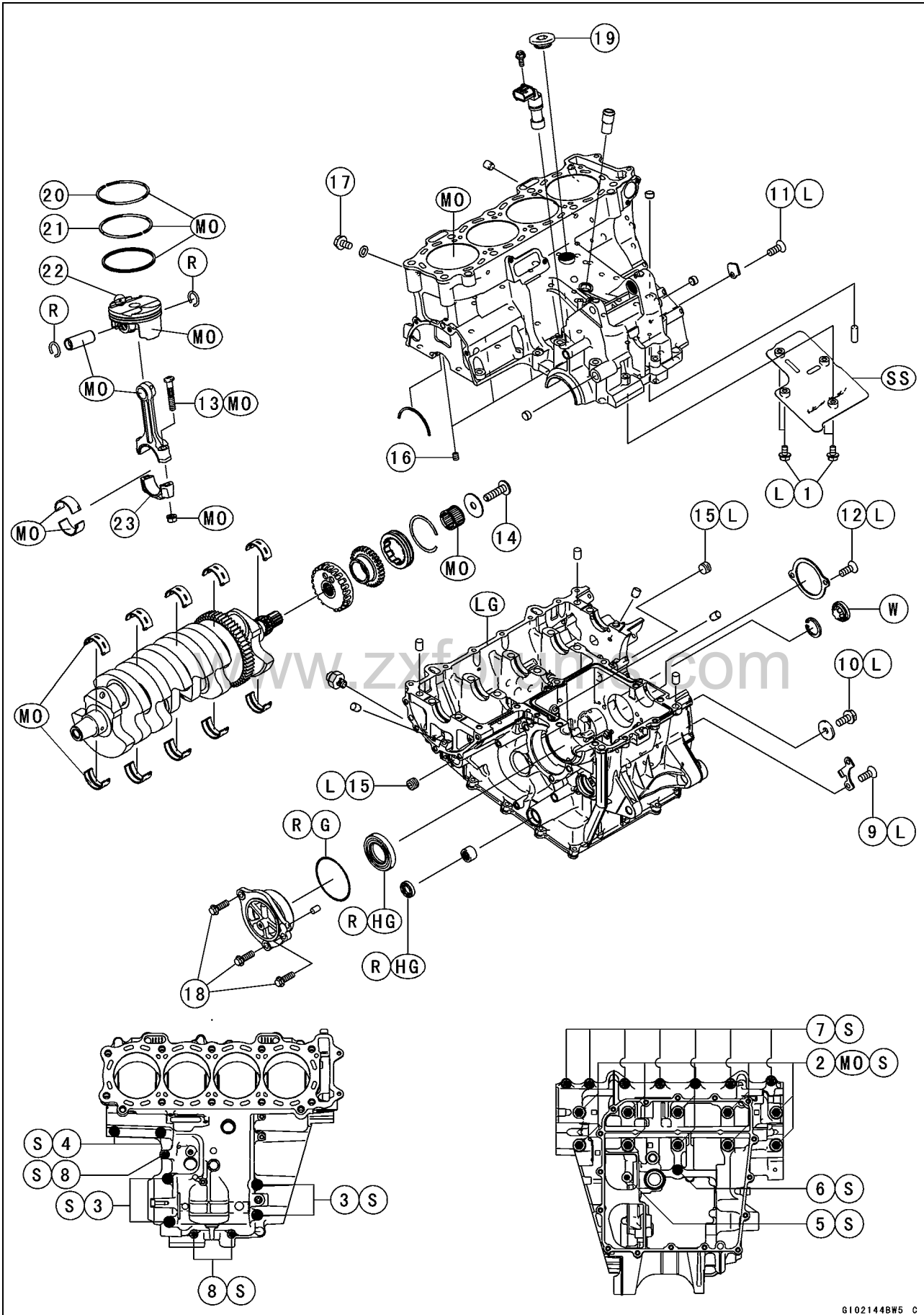

G102144BW5 C

Exploded View

No.	Fastener	Torque			Remarks
		N·m	kgf·m	ft·lb	
1	Breather Plate Bolts	10	1.0	89 in·lb	L
2	Crankcase Bolts (M9)	39	4.0	29	MO, S
3	Crankcase Bolts (M8)	27	2.8	20	S
4	Crankcase Bolts (M7, L = 32)	20	2.0	15	S
5	Crankcase Bolts (M7, L = 50)	20	2.0	15	S
6	Crankcase Bolts (M7, L = 85)	20	2.0	15	S
7	Crankcase Bolts (M6, L = 45)	12	1.2	106 in·lb	S
8	Crankcase Bolts (M6, L = 40)	12	1.2	106 in·lb	S
9	Shift Drum Bearing Holder Screws	5.0	0.51	44 in·lb	L
10	Shift Fork Hold Bolt	12	1.2	106 in·lb	L
11	Plate Screw	5.0	0.51	44 in·lb	L
12	Bearing Position Plate Screws	5.0	0.51	44 in·lb	L
13	Connecting Rod Bid End Bolts	see Text	←	←	MO
14	Starter Clutch Bolt	49	5.0	36 in·lb	
15	Oil Passage Plugs	20	2.0	15	L
16	Piston Oil Jet	3.0	0.31	27 in·lb	
17	Coolant Drain Plug (Cylinder)	10	1.0	89 in·lb	
18	Drive Shaft Cover Bolts	25	2.5	18	
19	Plug	20	2.0	15	

20. "R" marked side faces up.

21. "RN" marked side faces up.

22. Hollow mark faces exhaust side.

23. Do not apply any grease or oil.

G: Apply grease.

HG: Apply high-temperature grease.

L: Apply a non-permanent locking agent.

LG: Apply liquid gasket (Kawasaki Bond: 92104-1064).

MO: Apply molybdenum disulfide oil solution.

(mixture of engine oil and molybdenum disulfide grease in a weight ratio is 10 : 1)

R: Replacement Parts

S: Follow the specified tightening sequence.

SS: Apply silicone sealant (Three Bond 1207B).

W: Apply water.

9-4 CRANKSHAFT/TRANSMISSION

www.zxforums.com

www.zxforums.com

www.zxforums.com

Exploded View

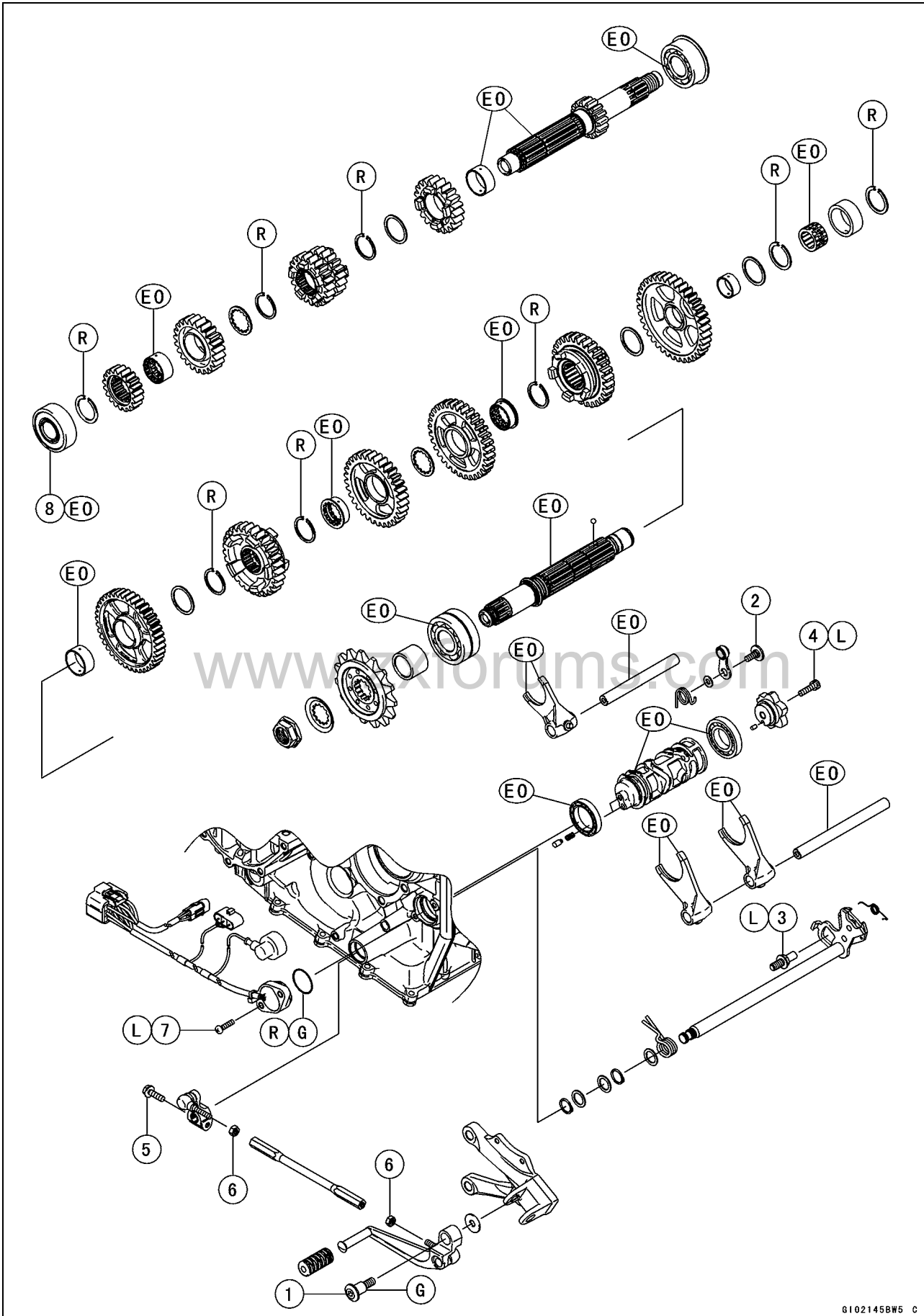

G102145BW5 C

Exploded View

No.	Fastener	Torque			Remarks
		N·m	kgf·m	ft·lb	
1	Shift Pedal Mounting Bolt	25	2.5	18	
2	Gear Position Lever Bolt	12	1.2	106 in·lb	
3	Shift Shaft Return Spring Pin	29	3.0	21	L
4	Shift Drum Cam Holder Bolt	12	1.2	106 in·lb	L
5	Shift Lever Bolt	7.0	0.71	62 in·lb	
6	Tie-Rod Locknuts	7.0	0.71	62 in·lb	
7	Gear Position Switch Screws	3.0	0.30	27 in·lb	L

8. Install the bearing into the drive shaft cover so that the shield side faces in.

EO: Apply engine oil.

G: Apply grease.

L: Apply a non-permanent locking agent.

R: Replacement Parts

www.zxforums.com

Specifications

Item	Standard	Service Limit
Crankcase, Crankshaft, Connecting Rods		
Connecting Rod Bend	---	TIR 0.2/100 mm (0.008/3.94 in.)
Connecting Rod Twist	---	TIR 0.2/100 mm (0.008/3.94 in.)
Connecting Rod Big End Side Clearance	0.13 ~ 0.38 mm (0.0051 ~ 0.0150 in.)	0.58 mm (0.023 in.)
Connecting Rod Big End Bearing Insert/crankpin Clearance	0.030 ~ 0.060 mm (0.0012 ~ 0.0024 in.)	0.10 mm (0.0039 in.)
Crankpin Diameter:	34.484 ~ 34.500 mm (1.3576 ~ 1.3583 in.)	34.47 mm (1.3571 in.)
Marking:		
None	34.484 ~ 34.492 mm (1.3576 ~ 1.3579 in.)	---
○	34.493 ~ 34.500 mm (1.3580 ~ 1.3583 in.)	---
Connecting Rod Big End Inside Diameter:	37.500 ~ 37.516 mm (1.4764 ~ 1.4770 in.)	---
Marking:		
None	37.500 ~ 37.508 mm (1.4764 ~ 1.4766 in.)	---
○	37.509 ~ 37.516 mm (1.4767 ~ 1.4770 in.)	---
Connecting Rod Big End Bearing Insert Thickness:		
Brown	1.478 ~ 1.483 mm (0.05819 ~ 0.05839 in.)	---
Black	1.483 ~ 1.488 mm (0.05839 ~ 0.05858 in.)	---
Blue	1.488 ~ 1.493 mm (0.05858 ~ 0.05878 in.)	---
Connecting Rod Bolt Stretch:	(Usable Range)	
New Connecting Rod	0.24 ~ 0.34 mm (0.0094 ~ 0.0134 in.)	---
Used Connecting Rod	0.24 ~ 0.34 mm (0.0094 ~ 0.0134 in.)	---
Crankshaft Side Clearance	0.05 ~ 0.20 mm (0.0020 ~ 0.0079 in.)	0.40 mm (0.0157 in.)
Crankshaft Runout	TIR 0.02 mm (0.0008 in.) or less	TIR 0.05 mm (0.0020 in.)
Crankshaft Main Bearing Insert/journal Clearance	0.010 ~ 0.034 mm (0.0004 ~ 0.0013 in.)	0.06 mm (0.0024 in.)
Crankshaft Main Journal Diameter:	34.984 ~ 35.000 mm (1.3773 ~ 1.3780 in.)	34.96 mm (1.3764 in.)
Marking:		
None	34.984 ~ 34.992 mm (1.3773 ~ 1.3776 in.)	---
1	34.993 ~ 35.000 mm (1.3777 ~ 1.3780 in.)	---
Crankcase Main Bearing Inside Diameter:	38.000 ~ 38.016 mm (1.4961 ~ 1.4967 in.)	---
Marking:		
○	38.000 ~ 38.008 mm (1.4961 ~ 1.4963 in.)	---
None	38.009 ~ 38.016 mm (1.4964 ~ 1.4967 in.)	---

Specifications

Item	Standard	Service Limit
Crankshaft Main Bearing Insert Thickness:		
Brown	1.491 ~ 1.495 mm (0.0587 ~ 0.0589 in.)	---
Black	1.495 ~ 1.499 mm (0.0589 ~ 0.0590 in.)	---
Blue	1.499 ~ 1.503 mm (0.0590 ~ 0.0592 in.)	---
Pistons		
Cylinder (Upper Crankcase) Inside Diameter	75.990 ~ 76.006 mm (2.9917 ~ 2.9924 in.)	76.09 mm (2.9957 in.)
Piston Diameter	75.959 ~ 75.974 mm (2.9905 ~ 2.9911 in.)	75.81 mm (2.9846 in.)
Piston/Cylinder Clearance	0.020 ~ 0.047 mm (0.0008 ~ 0.0019 in.)	---
Piston Ring/Groove Clearance:		
Top	0.03 ~ 0.07 mm (0.0012 ~ 0.0028 in.)	0.17 mm (0.0067 in.)
Second	0.03 ~ 0.07 mm (0.0012 ~ 0.0028 in.)	0.17 mm (0.0067 in.)
Piston Ring Groove Width:		
Top	0.82 ~ 0.84 mm (0.0323 ~ 0.0331 in.)	0.92 mm (0.036 in.)
Second	0.82 ~ 0.84 mm (0.0323 ~ 0.0331 in.)	0.92 mm (0.036 in.)
Piston Ring Thickness:		
Top	0.77 ~ 0.79 mm (0.0303 ~ 0.0311 in.)	0.70 mm (0.028 in.)
Second	0.77 ~ 0.79 mm (0.0303 ~ 0.0311 in.)	0.70 mm (0.028 in.)
Piston Ring End Gap:		
Top	0.15 ~ 0.30 mm (0.0059 ~ 0.0118 in.)	0.6 mm (0.024 in.)
Second	0.30 ~ 0.45 mm (0.0118 ~ 0.0177 in.)	0.8 mm (0.031 in.)
Transmission		
Shift Fork Ear Thickness	5.9 ~ 6.0 mm (0.232 ~ 0.236 in.)	5.8 mm (0.228 in.)
Gear Groove Width	6.05 ~ 6.15 mm (0.238 ~ 0.242 in.)	6.25 mm (0.246 in.)
Shift Fork Guide Pin Diameter	5.9 ~ 6.0 mm (0.232 ~ 0.236 in.)	5.8 mm (0.228 in.)
Shift Drum Groove Width	6.05 ~ 6.20 mm (0.238 ~ 0.244 in.)	6.3 mm (0.248 in.)

Specifications

Connecting Rod Big End Bearing Insert Selection

Con-rod Big End Bore Diameter Marking	Crankpin Diameter Marking	Bearing Insert	
		Size Color	Part Number
None	○	Brown	92139-0028
None	None	Black	92139-0027
○	○		
○	None	Blue	92139-0026

Crankshaft Main Bearing Insert Selection

Crankcase Main Bearing Inside Diameter Marking	Crankshaft Main Journal Diameter Marking	Bearing Insert		
		Size Color	Part Number	Journal Nos.
○	1	Brown	92139-0031	1, 5
			92139-0034	2, 3, 4
None	1	Black	92139-0030	1, 5
○	None		92139-0033	2, 3, 4
None	None	Blue	92139-0029	1, 5
			92139-0032	2, 3, 4

www.zxforums.com

Special Tools and Sealants

Bearing Puller:
57001-135

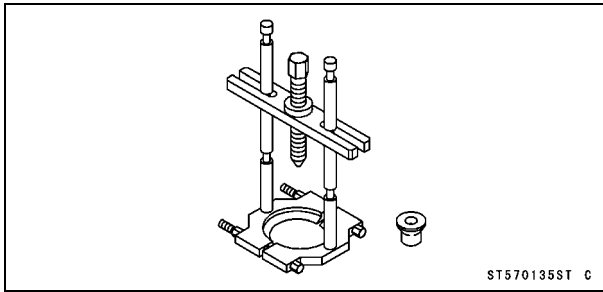

Piston Pin Puller Assembly:
57001-910

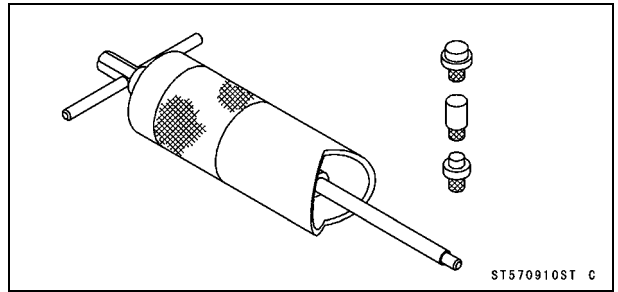

Outside Circlip Pliers:
57001-144

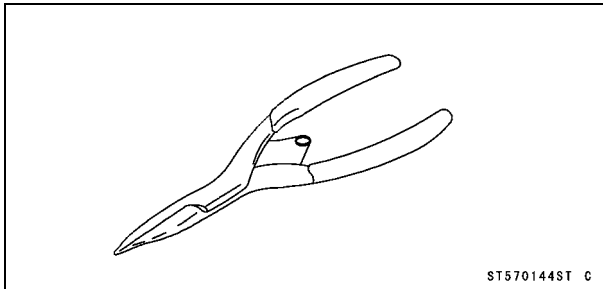

Piston Ring Compressor Grip:
57001-1095

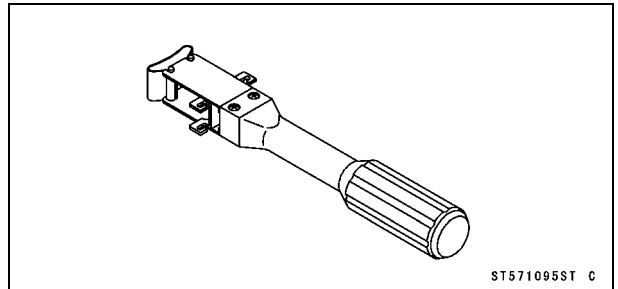

Bearing Puller Adapter:
57001-317

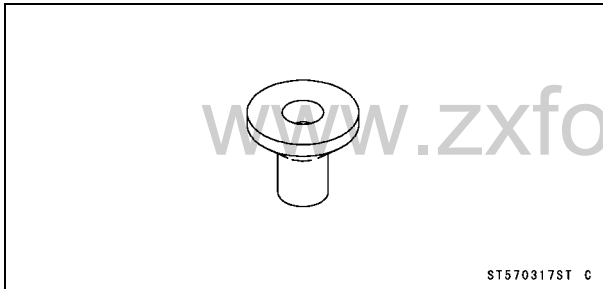

Piston Ring Compressor Belt, $\phi 67 \sim \phi 79$:
57001-1097

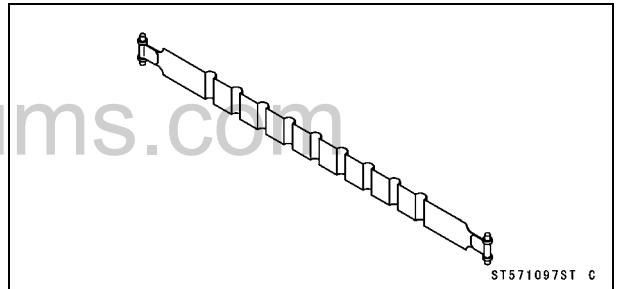

Bearing Driver, $\phi 32$:
57001-382

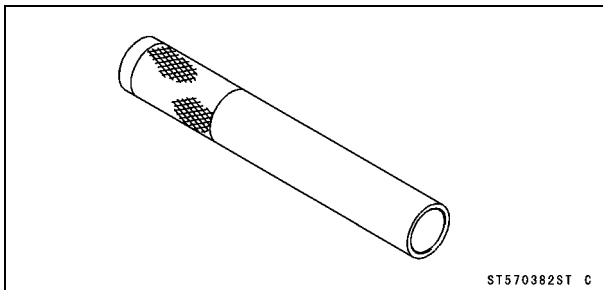

Kawasaki Bond:
92104-1064

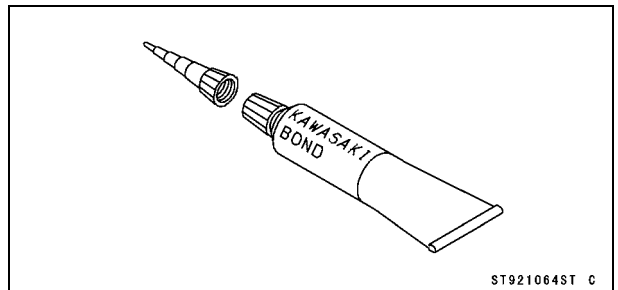

Crankcase Splitting

Crankcase Splitting

- Remove the engine (see Engine Removal in the Engine Removal/Installation chapter).
- Set the engine on a clean surface and hold the engine steady while parts are being removed.
- Remove:
 - Crankshaft Sensor (see Crankshaft Sensor Removal in the Electrical System chapter)
 - Starter Clutch (see Starter Clutch Removal in the Electrical System chapter)
 - Cylinder Head (see Cylinder Head Removal in the Engine Top End chapter)
 - Starter Motor (see Starter Motor Removal in the Electrical System chapter)
 - Clutch (see Clutch Removal in the Clutch chapter)
 - Oil Pump (see Oil Pump Removal in the Engine Lubrication System chapter)
 - Alternator Rotor (see Alternator Removal in the Electrical System chapter)
 - Oil Cooler/Oil Filter Case (see Oil Cooler/Oil Filter Case Removal in the Engine Lubrication System chapter)
 - Oil Pan (see Oil Pan Removal in the Engine Lubrication System chapter)
 - Oil Screen (see Oil Pressure Relief Valve Removal in the Engine Lubrication System chapter)
 - External Shift Mechanism (see External Shift Mechanism Removal)
- Remove the upper crankcase bolts, following the specified sequence.
 - Firstly, loosen the M6 bolts [A].
 - Secondly, loosen the M7 bolts [B].
 - Lastly, loosen the M8 bolts [C].

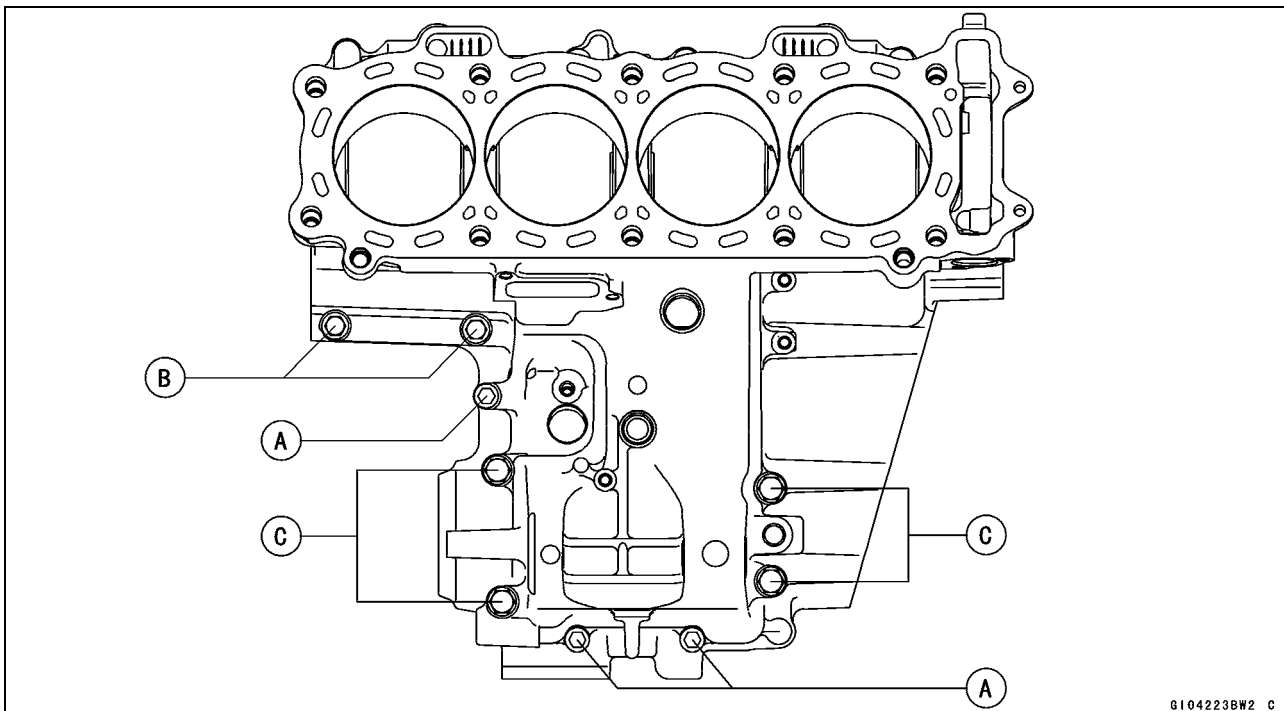

Crankcase Splitting

- Remove the lower crankcase bolts, following the specified sequence.
 - First, loosen the M6 bolts [A].
 - Second, loosen the M7 bolts [B].
 - Lastly, loosen the M9 bolts as shown sequence [1 ~ 10] in the figure.
- Tap lightly around the crankcase mating surface with a plastic mallet, and split the crankcase. Take care not to damage the crankcase.

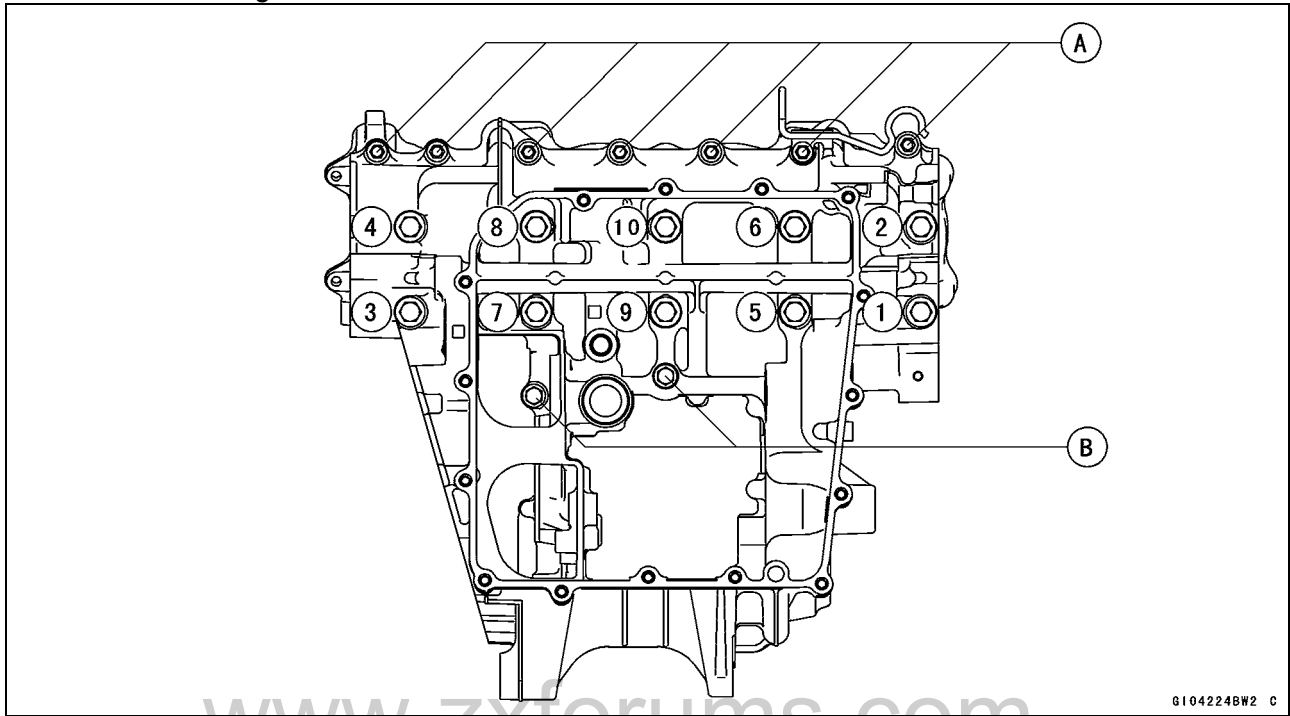

Crankcase Assembly

CAUTION

The upper and lower crankcase halves are machined at the factory in the assembled state, so the crankcase halves must be replaced as a set.

- With a high-flash point solvent, clean off the mating surfaces of the crankcase halves and wipe dry.

⚠ WARNING

Clean the crankcase in a well-ventilated area, and take care that there is no spark or flame anywhere near the working area. Because of the danger of highly flammable liquids, do not use gasoline or low-flash point solvent.

- Using compressed air, blow out the oil passage in the crankcase halves.
- Apply liquid gasket to the breather plate mating surface [A] 1 mm (0.04 in.) or more thick, and then install the breather plate.

Sealant - Three Bond: TB1207B

NOTE

- Make the application finish within 7 minutes when the liquid gasket to the mating surface of the breather plate is applied.
- Moreover fit the plate and tighten the bolts just after application of the liquid gasket.

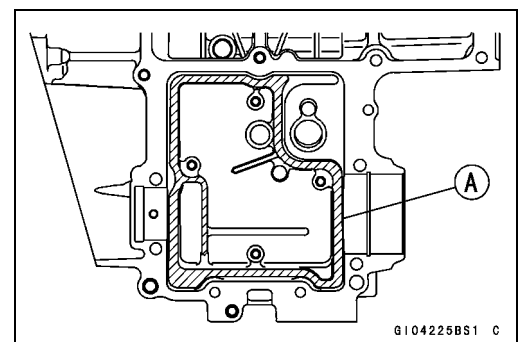

Crankcase Splitting

- Apply a non-permanent locking agent to the treads of the breather plate bolts [A] and tighten it.

Torque - Breather Plate Bolts: 10 N·m (1.0 kgf·m, 89 in·lb)

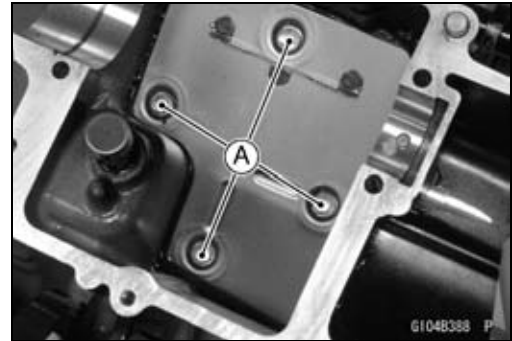

- Install the following in the upper crankcase.
 - Output Shaft [A] (see Transmission Shaft Installation)
 - Crankshaft [B] (see Crankshaft Installation)
 - Pistons and Connecting Rods [C] (see Connecting Rod Installation)
 - Camshaft Chain [D] (see Camshaft Chain Removal/Installation in the Engine Top End chapter)
 - Dowel Pins [E]

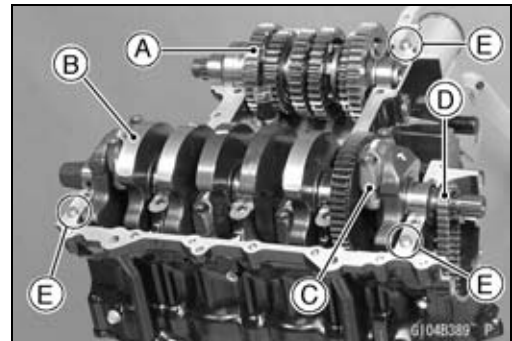

- Install the following in the lower crankcase.
 - Drive Shaft [A] (see Transmission Installation)
 - Shift Drum [B] (see Shift Drum and Fork Installation)
 - Shift Forks [C] and Shift Rods (see Shift Drum and Fork Installation)

www.zxforums.com

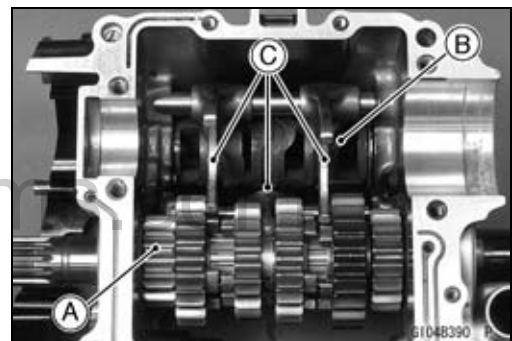

- Before fitting the lower case on the upper case, check the following.
 - Check to see that the shift drum cam [A] and transmission gears are in the neutral position [B].
 - Be sure hang the camshaft chain on the crankshaft.



Crankcase Splitting

- Apply liquid gasket [A] to the mating surface of the lower crankcase half.

Sealant - Kawasaki Bond: 92104-1064

NOTE

- Especially, apply a sealant so that it shall be filled up on the grooves.

CAUTION

Do not apply liquid gasket around the crankshaft main bearing inserts, and oil passage hole.

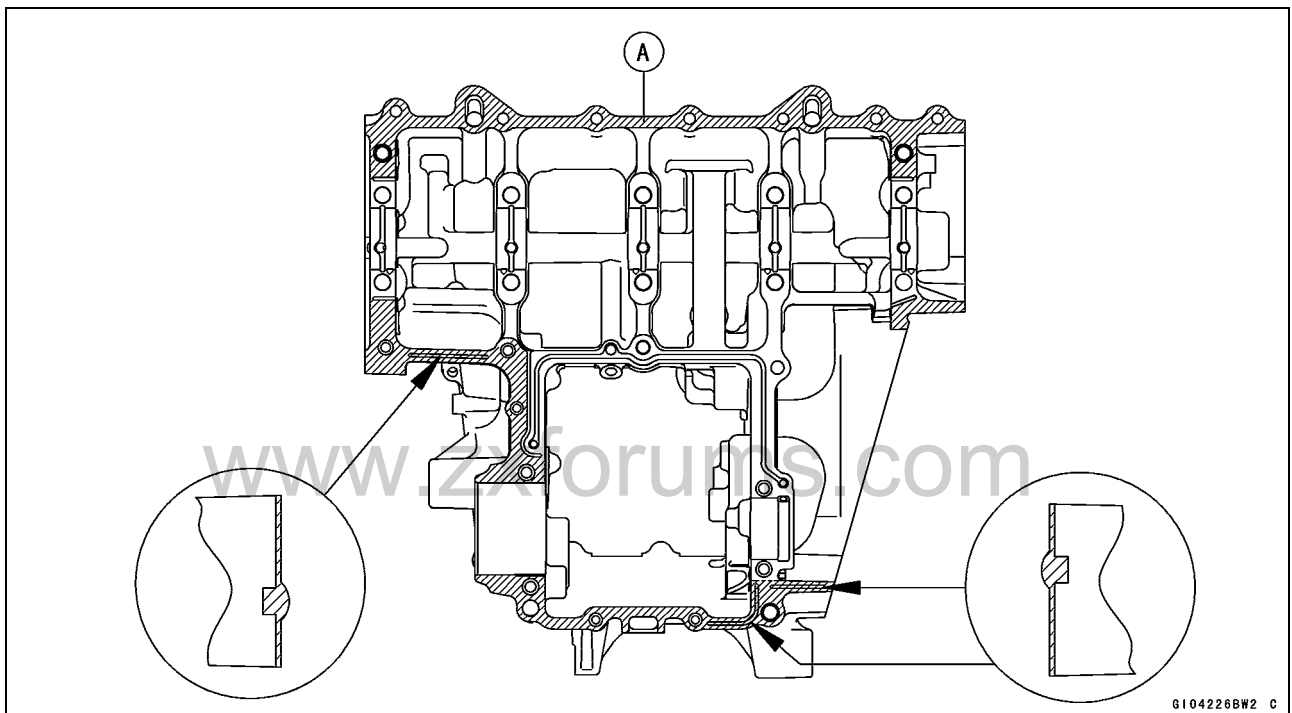

- Fit the lower crankcase half to the upper crankcase half.

NOTE

- Make the application finish within 20 minutes when the liquid gasket to the mating surface of the crankcase half is applied.
- Moreover fit the case and tighten the bolts just after application of the liquid gasket.

- The M9 bolts [A] has a copper plated washer [B], replace it with a new one.
- Apply molybdenum disulfide oil solution to both sides [C] of the washers and threads [D] of M9 bolts.

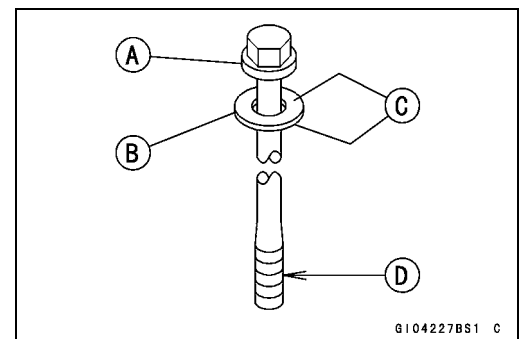

Crankcase Splitting

- Tighten the lower crankcase bolts using the following steps.
- Following the sequence numbers on the lower crankcase half, M9 bolts [1 ~ 10] with copper plated washers.
Torque - Crankcase Bolts (M9): 39 N·m (4.0 kgf·m, 29 ft·lb)
- Tighten the M7 bolts.
Torque - Crankcase Bolts (M7): 20 N·m (2.0 kgf·m, 15 ft·lb)
 - L = 50 mm (1.97 in.) [A]
 - L = 85 mm (3.35 in.) [B]
- Install the clamp [C], and tighten the M6 bolts [D].
Torque - Crankcase Bolts (M6): 12 N·m (1.2 kgf·m, 106 in·lb)

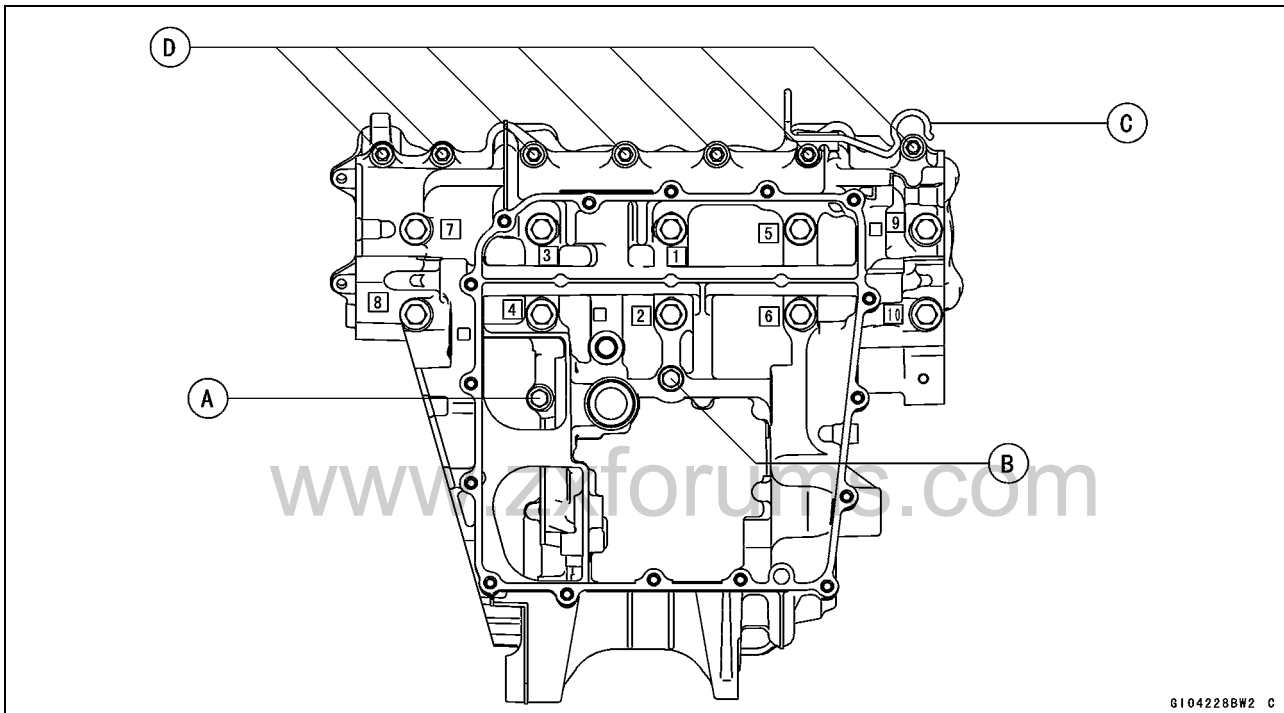

Crankcase Splitting

- Tighten the upper crankcase bolts using the following steps.

- The M8 bolts [A] has a washer, replace it with a new one.
- Tighten the M8 bolts with washers.

Torque - Crankcase Bolts (M8): 27 N·m (2.8 kgf·m, 20 ft·lb)

- Tighten the M7 bolts [B].

Torque - Crankcase Bolts (M7): 20 N·m (2.0 kgf·m, 15 ft·lb)

- Tighten the M6 bolts [C].

Torque - Crankcase Bolts (M6): 12 N·m (1.2 kgf·m, 106 in·lb)

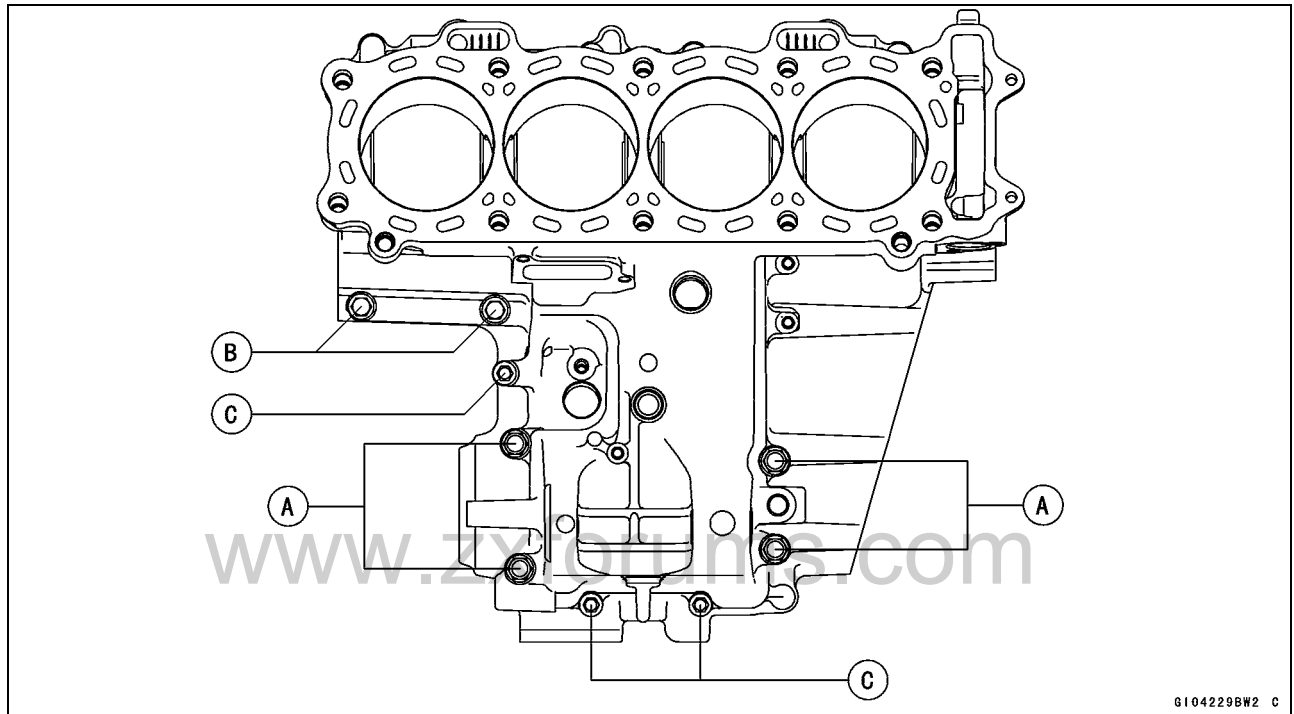

- After tightening all crankcase bolts, check the following items

- Wipe up the liquid gasket that seeps out around the crankcase mating surface.
- Crankshaft and transmission shaft turn freely.
- While spinning the output shaft, gears shift smoothly from the 1st to 6th gear, and 6th to 1st.
- When the output shaft stays still, the gear cannot be shifted to 2nd gear or other higher gear positions.
- Install the removed parts (see appropriate chapters).

Crankshaft and Connecting Rods

Crankshaft Removal

- Refer to the Connecting Rod Removal (see Connecting Rod Removal).

Crankshaft Installation

NOTE

○If the crankshaft is replaced with a new one, refer to the Connecting Rod Big End Bearing/Crankshaft Main Bearing Insert Selection in the Specifications.

CAUTION

If the crankshaft, bearing inserts, or crankcase halves are replaced with new ones, select the bearing inserts and check clearance with a plastigage (press gauge) before assembling engine to be sure the correct bearing inserts are installed.

- Apply molybdenum disulfide oil solution to the crankshaft main bearing inserts.
- Install the crankshaft with the camshaft chain [A] hanging on it.
- Install the connecting rod big end cap [B] (see Connecting Rod Installation).

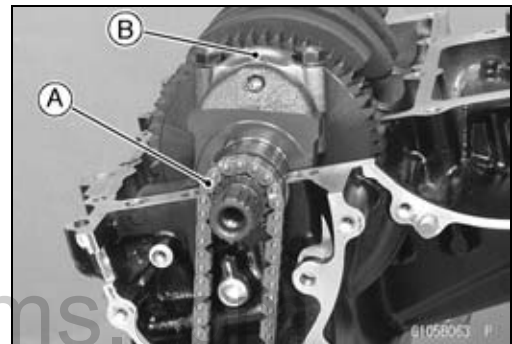

www.zxforums.com

Connecting Rod Removal

- Split the crankcase (see Crankcase Splitting).
- Remove the connecting rod nuts [A] and big end caps [B].

NOTE

○Mark and record the locations of the connecting rods and their big end caps so that they can be reassembled in their original positions.

- Remove:
 - Camshaft Chain (see Camshaft Chain Removal in the engine Top End chapter)
 - Crankshaft [A]
 - Pistons (see Piston Removal)

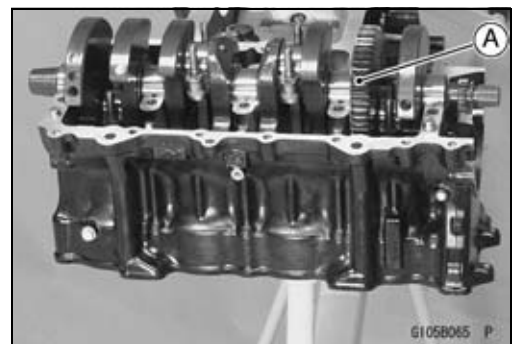
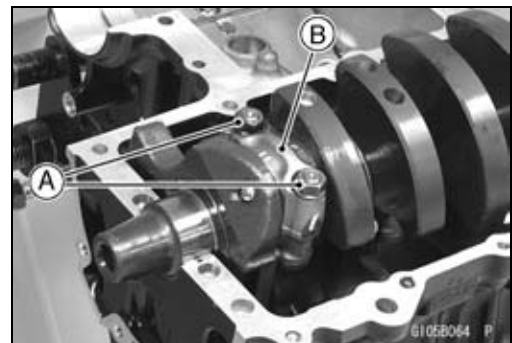

CAUTION

Discard the connecting rod bolts. To prevent damage to the crankpin surfaces, do not allow the connecting rod bolts to bump against the crankpins.

Crankshaft and Connecting Rods

Connecting Rod Installation

CAUTION

To minimize vibration, the connecting rods should have the same weight mark.

- Big End Cap [A]
- Connecting Rod [B]
- Weight Mark, Alphabet [C]
- Diameter Mark [D]: "O" or no mark

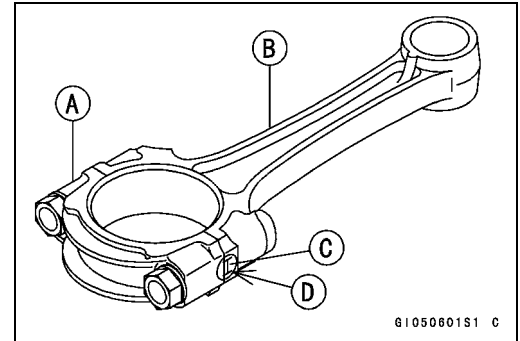

CAUTION

If the connecting rods, big end bearing inserts, or crankshaft are replaced with new ones, select the bearing insert and check clearance with a plasti-gage (press gauge) before assembling engine to be sure the correct bearing inserts are installed.

- Apply molybdenum disulfide oil solution to the inner surface of the upper and lower bearing inserts [A].
- Apply molybdenum disulfide oil solution to the threads [B] and seating surface [C] of the connecting rod nuts.
- Install the inserts so that their nails [D] are on the same side and fit them into the recess of the connecting rod and cap.

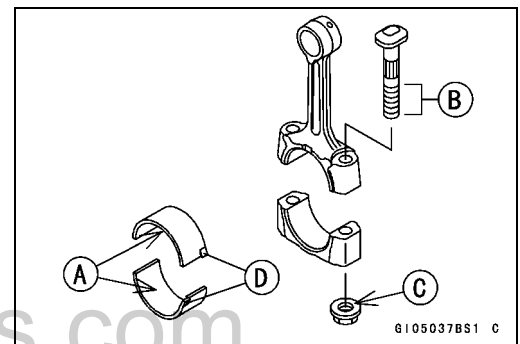

CAUTION

Wrong application of oil and grease could cause bearing damage.

- When installing the inserts [A], be careful not to damage the insert surface with the edge of the connecting rod [B] or the cap [C]. One way to install inserts is as follows.

- Installation [D] to Cap
- Installation [E] to Connecting Rod
- Push [F]
- Spare Dowel Pin [G]
- Connecting Rod Bolts [H]

- Remove debris and clean the surface of inserts.
- Install the cap on the connecting rod, aligning the weight and diameter marks.

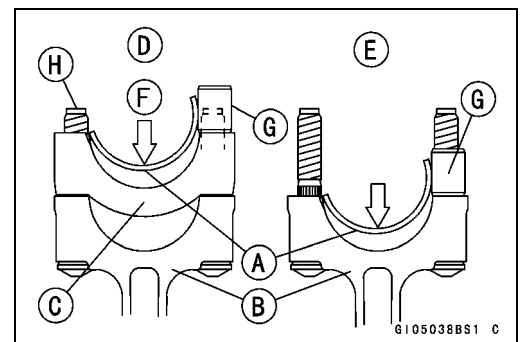

- Install each connecting rod on its original crankpin.
- The connecting rod big end is bolted using the "plastic region fastening method".
- This method precisely achieves the needed clamping force without exceeding it unnecessarily, allowing the use of thinner, lighter bolts further decreasing connecting rod weight.
- There are two types of the plastic region fastening. One is a bolt length measurement method and other is a rotation angle method. Observe one of the following two, but the bolt length measurement method is preferable because this is a more reliable way to tighten the big end nuts.

Crankshaft and Connecting Rods

CAUTION

The connecting rod bolts are designed to stretch when tightened. Never reuse the connecting rod bolts. See the table below for correct bolt and nut usage.

CAUTION

Be careful not to overtighten the nuts. The bolts must be positioned on the seating surface correctly to prevent the bolt heads from hitting the crankcase.

(1) Bolt Length Measurement Method

- Be sure to clean the bolts, nuts, and connecting rods thoroughly with a high-flash point solvent, because the new connecting rods, bolts, and nuts are treated with an anti-rust solution.

⚠ WARNING

Clean the bolts, nuts, and connecting rods in a well-ventilated area, and take care that there is no spark or flame anywhere near the working area. This includes any appliance with a pilot light. Because of the danger of highly flammable liquids, do not use gasoline or low-flash point solvents to clean them.

CAUTION

Immediately dry the bolts and nuts with compressed air after cleaning. Clean and dry the bolts and nuts completely.

Crankshaft and Connecting Rods

- Install new bolts in reused connecting rods.
- Dent both bolt head and bolt tip with a punch as shown.
- Before tightening, use a point micrometer to measure the length of new connecting rod bolts and record the values to find the bolt stretch.

Connecting Rod [A]

Dent here with a punch [B].

Nuts [C]

Fit micrometer pins into dents [D].

- Apply a small amount of molybdenum disulfide oil solution to the following.

Threads of Nuts and Bolts

Seating Surfaces of Nuts and Connecting rods

- Tighten the big end nuts until the bolt elongation reaches the length specified in the table.
- Check the length of the connecting rod bolts.
- ★ If the stretch is more than the usable range, the bolt has stretched too much. An overelongated bolt may break in use.

$$\text{Bolt Length after tightening} - \text{Bolt Length before tightening} = \text{Bolt Stretch}$$

Connecting Rod Assy	Bolt	Nut	Usable Range of Connecting Rod Bolt Stretch
New	Use the bolts attached to new con-rod.	Attached to new con-rod	0.24 ~ 0.34 mm (0.0094 ~ 0.0134 in.)
		New	
Used	Replace the bolts with new ones.	Used	0.24 ~ 0.34 mm (0.0094 ~ 0.0134 in.)
		New	

(2) Rotation Angle Method

- ★ If you don't have a point micrometer, you may tighten the nuts using the "Rotation Angle Method".
- Be sure to clean the bolts, nuts and connecting rods thoroughly with a high-flash point solvent, because the new connecting rods, bolts and nuts are treated with an anti-rust solution.

⚠ WARNING

Clean the bolts, nuts and connecting rods in a well-ventilated area, and take care that there is no spark or flame anywhere near the working area. This includes any appliance with a pilot light. Because of the danger or highly flammable liquids, do not use gasoline or low-flash point solvents to clean them.

CAUTION

**Immediately dry the bolts and nuts with compressed air after cleaning.
Clean and dry the bolts and nuts completely.**

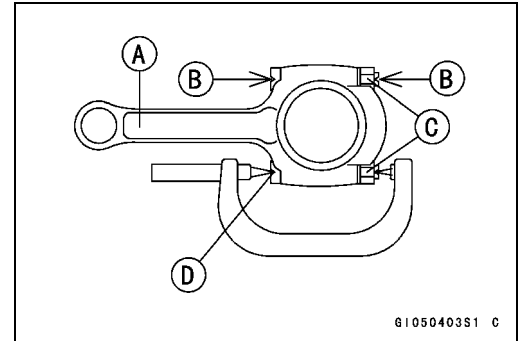

Crankshaft and Connecting Rods

- Install new bolts in reused connecting rods.
- Apply a small amount of molybdenum disulfide oil solution to the following.
 - Threads [A] of Nuts and Bolts
 - Seating Surfaces [B] of Nuts and Connecting Rods

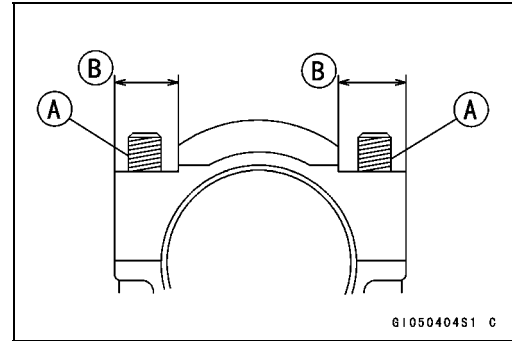

- First, tighten the nuts to the specified torque. See the table below.
 - Next, tighten the nuts **150°**.
- Mark [A] the connecting rod big end caps and nuts so that nuts can be turned 150° [B] properly.

Connecting Rod Assy	Bolt	Nut	Torque + Angle N·m (kgf·m, ft·lb)
New	Use the bolts attached to new con-rod.	Attached to new con-rod	20 (2.0, 15) + 150°
		New	20 (2.0, 15) + 150°
Used	Replace the bolts with new ones	Used	20 (2.0, 15) + 150°
		New	20 (2.0, 15) + 150°

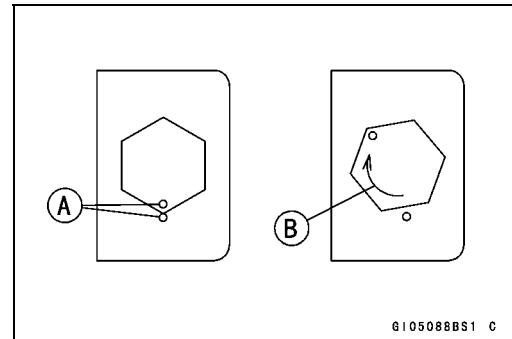

Crankshaft/Connecting Rod Cleaning

- After removing the connecting rods from the crankshaft, clean them with a high-flash point solvent.
- Blow the crankshaft oil passages with compressed air to remove any foreign particles or residue that may have accumulated in the passages.

Connecting Rod Bend

- Remove the connecting rod big end bearing inserts, and reinstall the connecting rod big end cap.
 - Select an arbor [A] of the same diameter as the connecting rod big end, and insert the arbor through the connecting rod big end.
 - Select an arbor of the same diameter as the piston pin and at least 100 mm (3.94 in.) long, and insert the arbor [B] through the connecting rod small end.
 - On a surface plate, set the big-end arbor on V block [C].
 - With the connecting rod held vertically, use a height gauge to measure the difference in the height of the arbor above the surface plate over a 100 mm (3.94 in.) length to determine the amount of connecting rod bend.
- ★ If connecting rod bend exceeds the service limit, the connecting rod must be replaced.

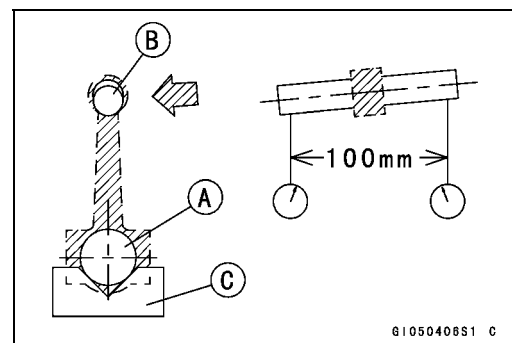

Connecting Rod Bend

Service Limit: TIR 0.2/100 mm (0.008/3.94 in.)

Crankshaft and Connecting Rods

Connecting Rod Twist

- With the big-end arbor [A] still on V block [C], hold the connecting rod horizontally and measure the amount that the arbor [B] varies from being paralleled with the surface plate over a 100 mm (3.94 in.) length of the arbor to determine the amount of connecting rod twist.
- ★ If connecting rod twist exceeds the service limit, the connecting rod must be replaced.

Connecting Rod Twist

Service Limit: TIR 0.2/100 mm (0.008/3.94 in.)

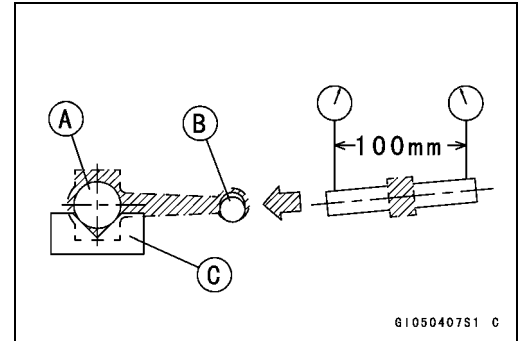

Connecting Rod Big End Side Clearance

- Measure connecting rod big end side clearance.
- Insert a thickness gauge [A] between the big end and either crank web to determine clearance.

Connecting Rod Big End Side Clearance

Standard: 0.13 ~ 0.38 mm (0.0051 ~ 0.0150 in.)

Service Limit: 0.58 mm (0.023 in.)

- ★ If the clearance exceeds the service limit, replace the connecting rod with new one and then check clearance again. If clearance is too large after connecting rod replacement, the crankshaft also must be replaced.

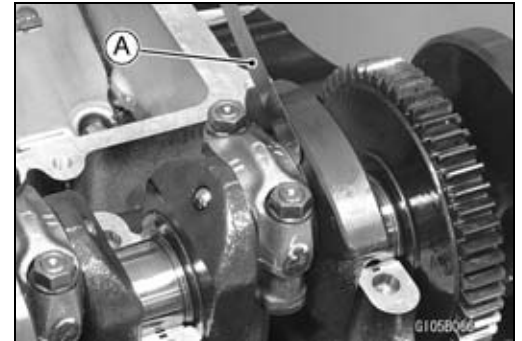

Connecting Rod Big End Bearing Insert/Crankpin Wear

- Measure the bearing insert/crankpin [B] clearance with plastigage [A].
- Tighten the big end nuts to the specified torque (see Connecting Rod Installation).

NOTE

- Do not move the connecting rod and crankshaft during clearance measurement.

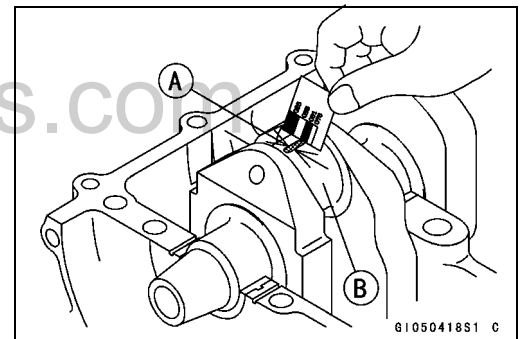

CAUTION

After measurement, replace the connecting rod bolts.

Connecting Rod Big End Bearing Insert/Crankpin Clearance

Standard: 0.030 ~ 0.060 mm (0.0012 ~ 0.0024 in.)

Service Limit: 0.10 mm (0.0039 in.)

Crankshaft and Connecting Rods

- ★ If the clearance is within the standard, no bearing replacement is required.
- ★ If the clearance is between 0.061 mm (0.0024 in.) and the service limit (0.10 mm, 0.0039 in.), replace the bearing inserts [A] with inserts painted blue [B]. Check insert/crankpin clearance with the plastigage. The clearance may exceed the standard slightly, but it must not be less than the minimum in order to avoid bearing seizure.
- ★ If the clearance exceeds the service limit, measure the diameter of the crankpins.

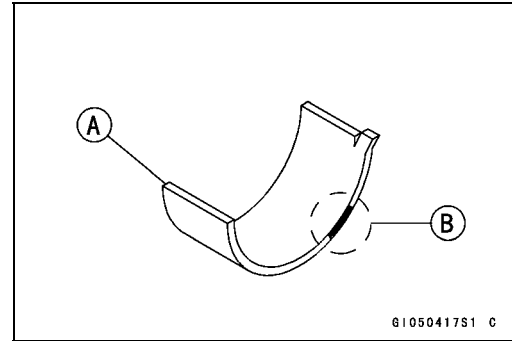

Crankpin Diameter

Standard: 34.484 ~ 34.500 mm (1.3576 ~ 1.3583 in.)

Service Limit: 34.47 mm (1.3571 in.)

- ★ If any crankpin has worn past the service limit, replace the crankshaft with a new one.
- ★ If the measured crankpin diameters are not less than the service limit, but do not coincide with the original diameter markings on the crankshaft, make new marks on it.

NOTE

○ There are two types [C] [D] of marking positions.

Crankpin Diameter Marks

None 34.484 ~ 34.492 mm (1.3576 ~ 1.3579 in.)

○ **34.493 ~ 34.500 mm (1.3580 ~ 1.3583 in.)**

△: Crankpin Diameter Marks, "○" or no mark.

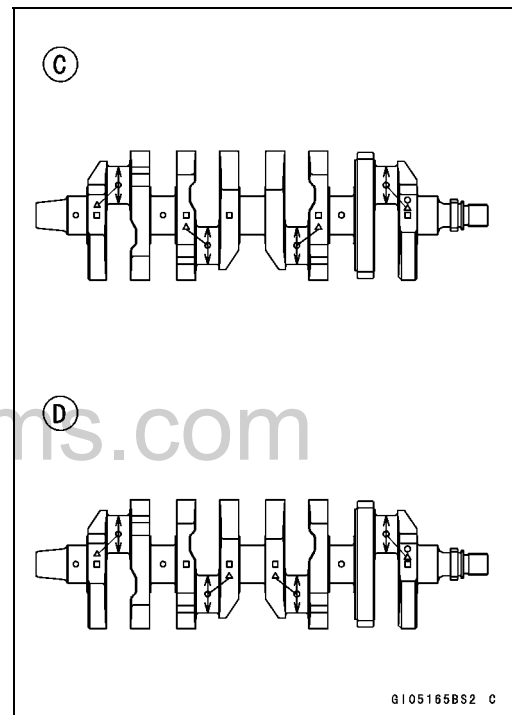

- Measure the connecting rod big end inside diameter, and mark each connecting rod big end in accordance with the inside diameter.
- Tighten the connecting rod big end nuts to the specified torque (see Connecting Rod Installation).

NOTE

○ The mark already on the big end should almost coincide with the measurement.

Crankshaft and Connecting Rods

Connecting Rod Big End Inside Diameter Marks

None 37.500 ~ 37.508 mm (1.4764 ~ 1.4766 in.)

○ 37.509 ~ 37.516 mm (1.4767 ~ 1.4770 in.)

Big End Cap [A]

Connecting Rod [B]

Weight Mark, Alphabet [C]

Diameter Mark (Around Weight Mark) [D]: "○" or no mark

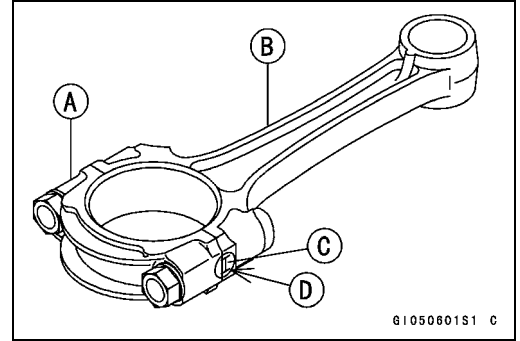

- Select the proper bearing insert [A] in accordance with the combination of the connecting rod and crankshaft coding. Size Color [B]

Con-rod Big End Inside Diameter Marking	Crankpin Diameter Marking	Bearing Insert	
		Size Color	Part Number
None	○	Brown	92139-0028
None	None	Black	92139-0027
○	○		
○	None	Blue	92139-0026

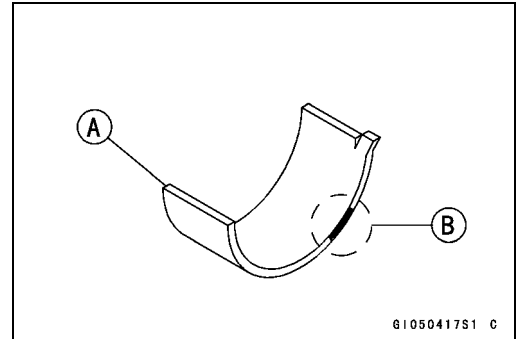

- Install the new inserts in the connecting rod and check insert/crankpin clearance with the plastigage.

Crankshaft Side Clearance

- Insert a thickness gauge [A] between the crankcase main bearing and the crank web at the No.2 journal [B] to determine clearance.

★ If the clearance exceeds the service limit, replace the crankcase halves as a set.

NOTE

○ The upper and lower crankcase halves are machined at the factory in the assembled state, so the crankcase halves must be replaced as a set.

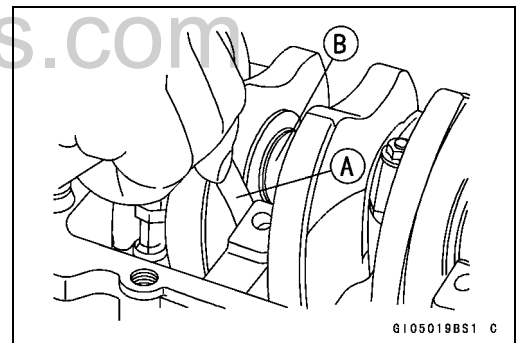

Crankshaft Side Clearance

Standard: 0.05 ~ 0.20 mm (0.0020 ~ 0.0079 in.)

Service Limit: 0.40 mm (0.0157 in.)

Crankshaft Runout

- Measure the crankshaft runout.
- ★ If the measurement exceeds the service limit, replace the crankshaft.

Crankshaft Runout

Standard: TIR 0.02 mm (0.0008 in.) or less

Service Limit: TIR 0.05 mm (0.0020 in.)

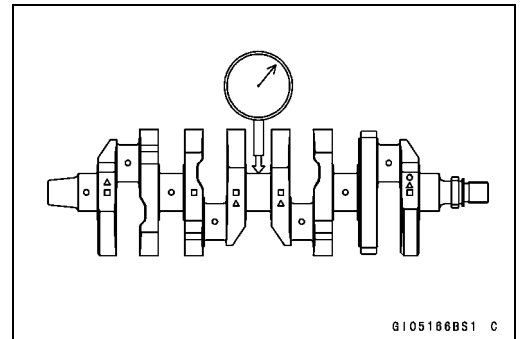

Crankshaft and Connecting Rods

Crankshaft Main Bearing Insert/Journal Wear

- Using a plastigage (press gauge) [A], measure the bearing insert/journal [B] clearance.

NOTE

- Tighten the crankcase bolts to the specified torque (see Crankcase Assembly).
- Do not turn the crankshaft during clearance measurement.
- Journal clearance less than 0.025 mm (0.00098 in.) can not be measured by plastigage, however, using genuine parts maintains the minimum standard clearance.

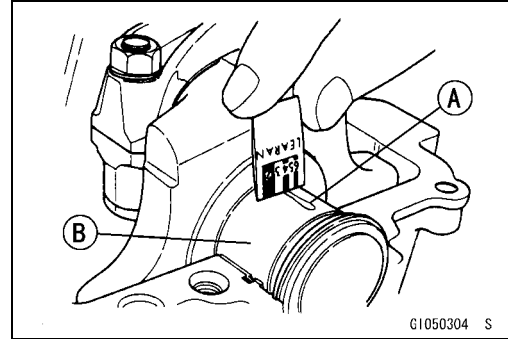

Crankshaft Main Bearing Insert/Journal Clearance

Standard: 0.010 ~ 0.034 mm (0.0004 ~ 0.0013 in.)

Service Limit: 0.06 mm (0.0024 in.)

- ★ If the clearance is within the standard, no bearing replacement is required.
- ★ If the clearance is between 0.035 mm (0.0014 in.) and the service limit (0.06 mm, 0.0024 in.), replace the bearing inserts [A] with inserts painted blue [B]. Check insert/journal clearance with the plastigage. The clearance may exceed the standard slightly, but it must not be less than the minimum in order to avoid bearing seizure.
- ★ If the clearance exceeds the service limit, measure the diameter of the crankshaft main journal.

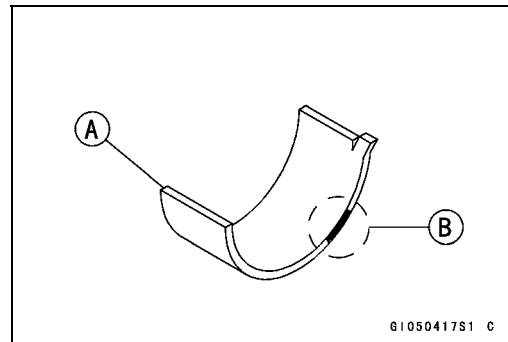

Crankshaft Main Journal Diameter

Standard: 34.984 ~ 35.000 mm (1.3773 ~ 1.3780 in.)

Service Limit: 34.96 mm (1.3764 in.)

- ★ If any journal has worn past the service limit, replace the crankshaft with a new one.
- ★ If the measured journal diameters are not less than the service limit, but do not coincide with the original diameter markings on the crankshaft, make new marks on it.

NOTE

- There are two types [C] [D] of marking positions.

Crankshaft Main Journal Diameter Marks

None 34.984 ~ 34.992 mm (1.3773 ~ 1.3776 in.)

1 34.993 ~ 35.000 mm (1.3777 ~ 1.3780 in.)

- : Crankshaft Main Journal Diameter Marks, "1" or no mark.

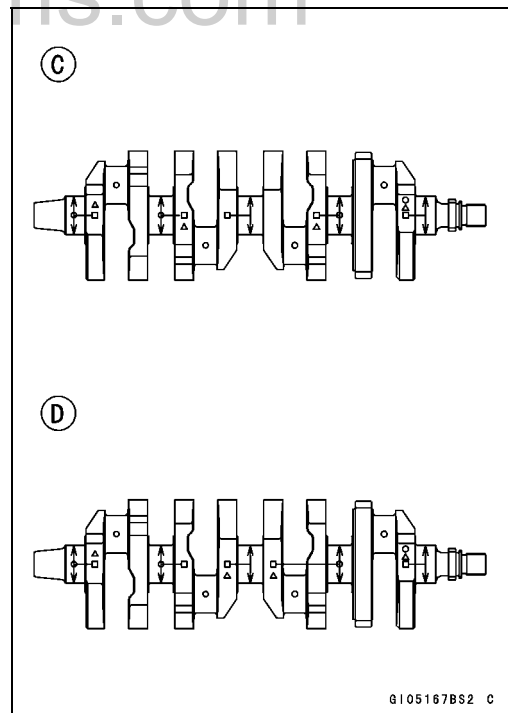

Crankshaft and Connecting Rods

- Measure the main bearing inside diameter, and mark the upper crankcase half in accordance with the inside diameter.
A: Crankcase Main Bearing Inside Diameter Marks, "○" mark or no mark.
- Tighten the crankcase bolts to the specified torque (see Crankcase Assembly).

NOTE

○ *The mark already on the upper crankcase half should almost coincide with the measurement.*

Crankcase Main Bearing Inside Diameter Marks

○ 38.000 ~ 38.008 mm (1.4961 ~ 1.4963 in.)

None 38.009 ~ 38.016 mm (1.4964 ~ 1.4967 in.)

- Select the proper bearing insert [A] in accordance with the combination of the crankcase and crankshaft coding.
Size Color [B]

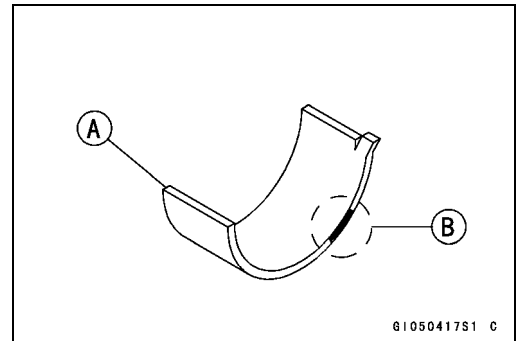
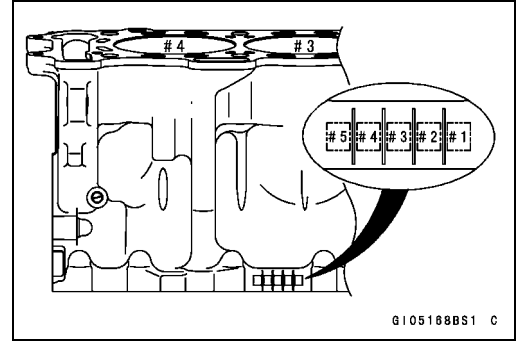

Crankcase Main Bearing Inside Diameter Marking	Crankshaft Main Journal Diameter Marking	Bearing Insert		
		Size Color	Part Number	Journal Nos.
○	1	Brown	92139-0031	1, 5
			92139-0034	2, 3, 4
None	1	Black	92139-0030	1, 5
○	None		92139-0033	2, 3, 4
None	None	Blue	92139-0029	1, 5
			92139-0032	2, 3, 4

- Install the new inserts in the crankcase halves and check insert/journal clearance with the plastigage.

Pistons

Piston Removal

- Split the crankcase (see Crankcase Splitting).
- Remove the connecting rod nuts [A] and big end caps [B].

NOTE

○Mark and record the locations of the connecting rods and their big end caps so that they can be reassembled in their original positions.

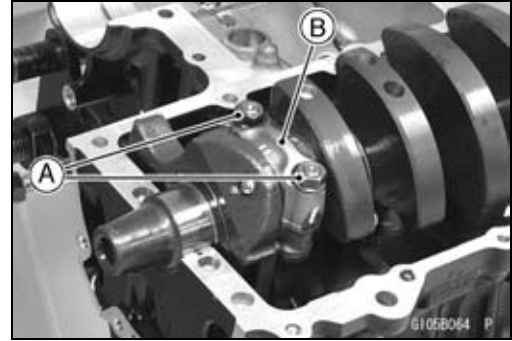

- Remove:
 - Camshaft Chain (see Camshaft Chain Removal in the engine Top End chapter)
 - Crankshaft [A]
- Remove the connecting rods with pistons to the cylinder head side [B].

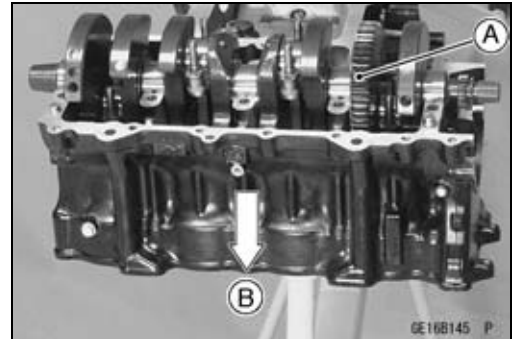

- Remove the piston pin snap rings [A].

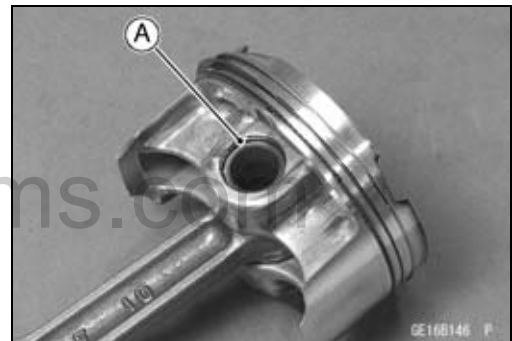

www.zxforums.com

- Using the piston pin puller assembly [A], remove the piston pins.
 - Special Tool - Piston Pin Puller Assembly: 57001-910**
- Remove the pistons.

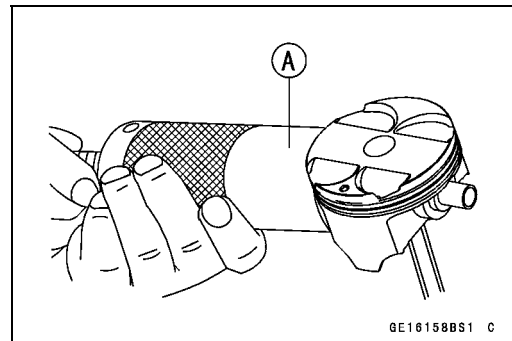

- Carefully spread the ring opening with your thumbs and then push up on the opposite side of the ring [A] to remove it.
- Remove the 3-piece oil ring with your thumbs in the same manner.

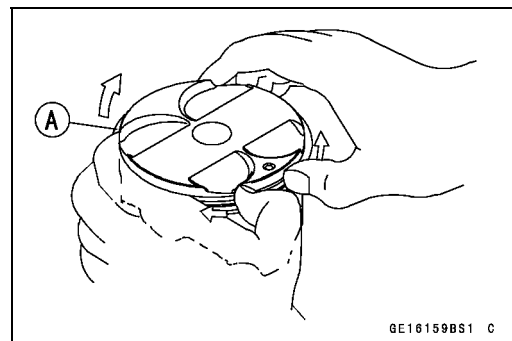

Pistons

Piston Installation

- Apply molybdenum disulfide oil solution to the oil ring expander, and install the oil ring expander [A] in the bottom piston ring groove so the ends [B] butt together.
- Apply molybdenum disulfide oil solution to the oil ring steel rails, and install the oil ring steel rails, one above the expander and one below it.
- Spread the rail with your thumbs, but only enough to fit the rail over the piston.
- Release the rail into the bottom piston ring groove.

NOTE

- The oil ring rails have no "top" or "bottom".

- Do not mix up the top and second ring.
- Install the top ring [A] so that the "R" mark [B] faces up.
- Install the second ring [C] so that the "RN" mark [D] faces up.
- Apply molybdenum disulfide oil solution to the piston rings.

NOTE

- If a new piston is used, use new piston ring.

- Fit a new piston pin snap ring into the side of the piston so that the ring opening [A] does not coincide with the slit [B] of the piston pin hole.
- Apply molybdenum disulfide oil solution to the piston pins and piston journals.
- When installing the piston pin snap ring, compress it only enough to install it and no more.

CAUTION

Do not reuse snap rings, as removal weakens and deforms them. They could fall out and score the cylinder wall.

- The piston ring openings must be positioned as shown in the figure. The openings of the oil ring steel rails must be about 30 ~ 40° of angle from the opening of the top ring.
- Top Ring [A]
 Second Ring [B]
 Oil Ring Steel Rails [C]
 Oil Ring Expander [D]
 Hollow [E]
 30 ~ 40° [F]

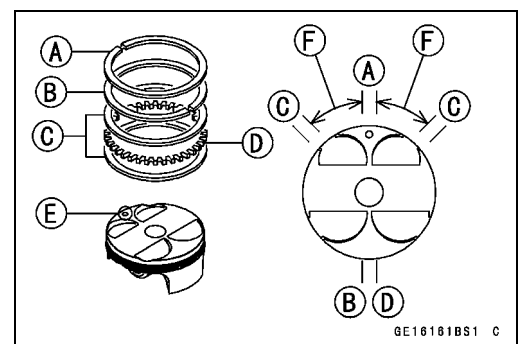
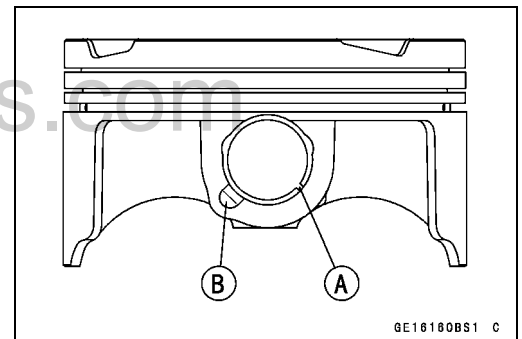
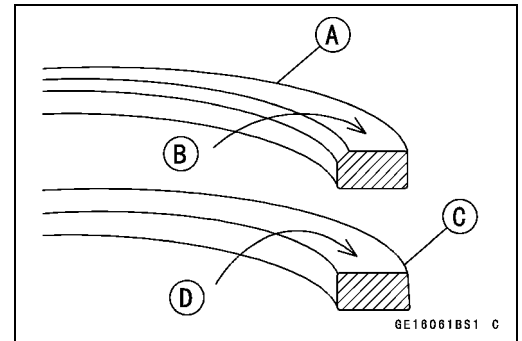
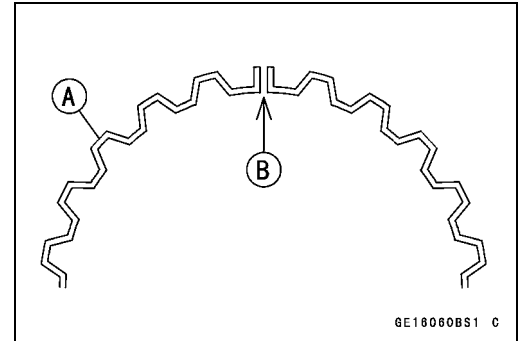

Pistons

- Apply molybdenum disulfide oil solution to the cylinder bore and piston skirt.
- Install the piston with its marking hollow [A] facing exhaust side.
- Using the piston ring compressor assembly [B] to install the piston from the cylinder head side.

Special Tools - Piston Ring Compressor Grip: 57001-1095
Piston Ring Compressor Belt, $\phi 67 \sim \phi 79$: 57001-1097

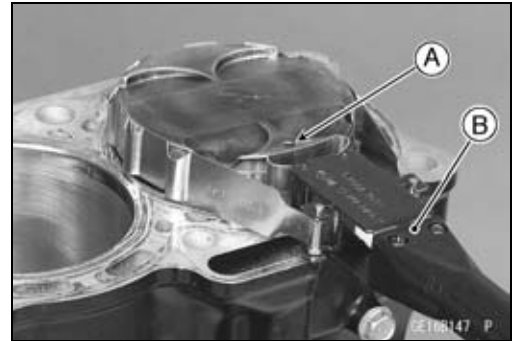

- Install:
 Crankshaft (see Crankshaft Installation)
 Connecting Rod Big End Cap (see Connecting Rod Installation)

Cylinder Wear (Upper Crankcase)

- Since there is a difference in cylinder wear (upper crankcase) in different directions, take a side-to-side and a front-to-back measurement at each of the two locations (total of four measurements) shown in the figure.
- ★ If any of the cylinder inside diameter measurements exceeds the service limit, replace the crankcase.
 10 mm (0.39 in.) [A]
 60 mm (2.36 in.) [B]

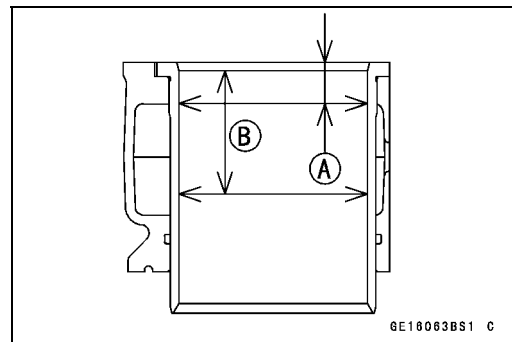

Cylinder Inside Diameter

Standard: 75.990 ~ 76.006 mm (2.9917 ~ 2.9924 in.)

Service Limit: 76.09 mm (2.9957 in.)

Piston Wear

- Measure the outside diameter [A] of each piston 5 mm (0.20 in.) [B] up from the bottom of the piston at a right angle to the direction of the piston pin.
- ★ If the measurement is under service limit, replace the piston.

Piston Diameter

Standard: 75.959 ~ 75.974 mm (2.9905 ~ 2.9911 in.)

Service Limit: 75.81 mm (2.9846 in.)

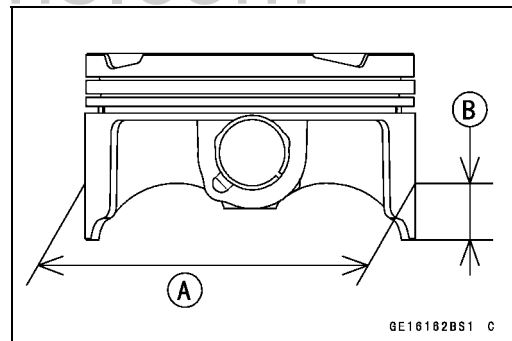

Piston Ring, Piston Ring Groove Wear

- Check for uneven groove wear by inspecting the ring seating.
- ★ The rings should fit perfectly parallel to groove surfaces. If not, replace the piston and all the piston rings.
- With the piston rings in their grooves, make several measurements with a thickness gauge [A] to determine piston ring/groove clearance.

Piston Ring/Groove Clearance

Standard:

Top 0.03 ~ 0.07 mm (0.0012 ~ 0.0028 in.)

Second 0.03 ~ 0.07 mm (0.0012 ~ 0.0028 in.)

Service Limit:

Top 0.17 mm (0.0067 in.)

Second 0.17 mm (0.0067 in.)

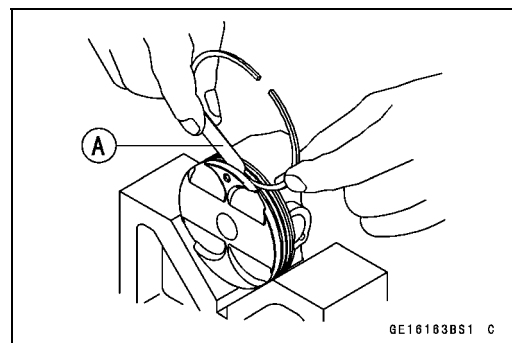

Pistons

Piston Ring Groove Width

- Measure the piston ring groove width.
- Use a vernier caliper at several points around the piston.

Piston Ring Groove Width

Standard:

Top [A] 0.82 ~ 0.84 mm (0.0323 ~ 0.0331 in.)

Second [B] 0.82 ~ 0.84 mm (0.0323 ~ 0.0331 in.)

Service Limit:

Top [A] 0.92 mm (0.036 in.)

Second [B] 0.92 mm (0.036 in.)

- ★ If the width of any of the two grooves is wider than the service limit at any point, replace the piston.

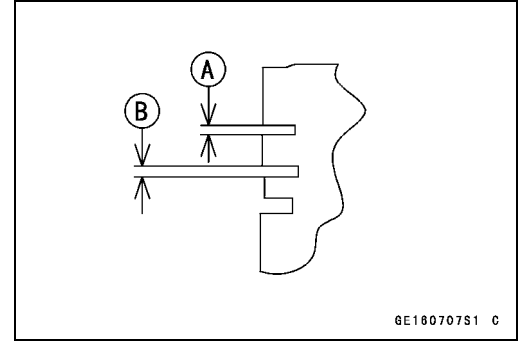

Piston Ring Thickness

- Measure the piston ring thickness.
- Use the micrometer to measure at several points around the ring.

Piston Ring Thickness

Standard:

Top [A] 0.77 ~ 0.79 mm (0.0303 ~ 0.0311 in.)

Second [B] 0.77 ~ 0.79 mm (0.0303 ~ 0.0311 in.)

Service Limit:

Top [A] 0.70 mm (0.028 in.)

Second [B] 0.70 mm (0.028 in.)

- ★ If any of the measurements is less than the service limit on either of the rings, replace all the rings.

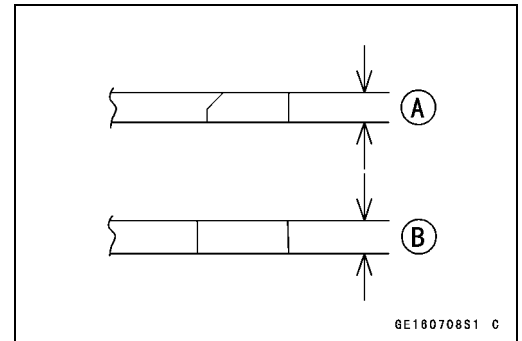

NOTE

- When using new rings in a used piston, check for uneven groove wear. The rings should fit perfectly parallel to the groove sides. If not, replace the piston.

Piston Ring End Gap

- Place the piston ring [A] inside the cylinder (upper crankcase), using the piston to locate the ring squarely in place. Set it close to the bottom of the cylinder, where cylinder wear is low.
- Measure the gap [B] between the ends of the ring with a thickness gauge.

Piston Ring End Gap

Standard:

Top 0.15 ~ 0.30 mm (0.0059 ~ 0.0118 in.)

Second 0.30 ~ 0.45 mm (0.0118 ~ 0.0177 in.)

Service Limit:

Top 0.6 mm (0.024 in.)

Second 0.8 mm (0.031 in.)

- ★ If the end gap of either ring is greater than the service limit, replace all the rings.

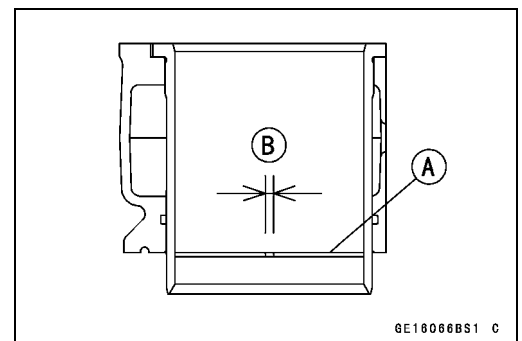

Transmission

Shift Pedal Removal

- Mark [A] the position of the shift lever [B] on the shift shaft so that it can be installed later in the same position.
- Remove:
 - Left Lower Fairing (see Lower Fairing Removal in the Frame chapter)
 - Shift Lever Bolt [C]
 - Shift Lever

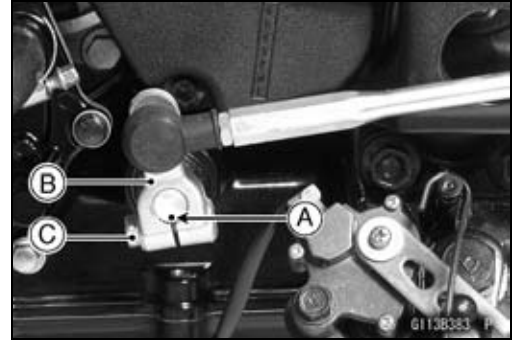

- Remove:
 - Shift Pedal Mounting Bolt [A]
 - Tie-rod [B]

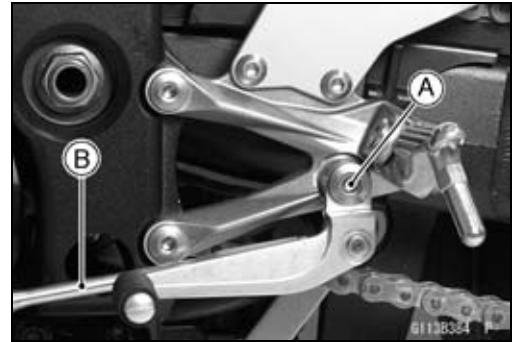

Shift Pedal Installation

- Apply grease to the sliding surfaces [A] on the shift pedal mounting bolt [B].
- Tighten:
 - Torque - Shift Pedal Mounting Bolt: 25 N·m (2.5 kgf·m, 18 ft·lb)**
 - Footpeg Bracket [C]
 - Shift Pedal [D]
 - Washer [E]

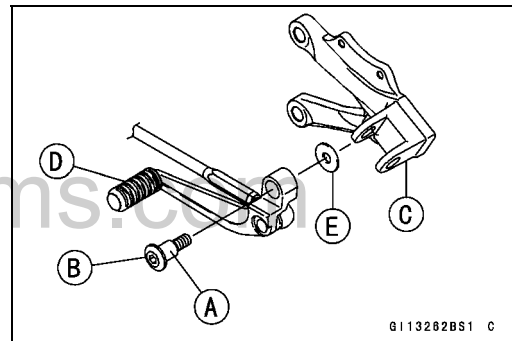

- Install the shift lever [A], aligning the mark (previously marked).
- Tighten:

Torque - Shift Lever Bolt: 7.0 N·m (0.70 kgf·m, 62 in·lb)

- Install the shift pedal [B] as shown.
 - About 90° [C]
 - About 8.25° [D]
- To adjust the pedal position, loosen the front locknut [E] (left-hand threads) and rear locknut [F] and then turn the tie-rod [G].
- Tighten:
 - Torque - Tie-Rod Locknuts: 7.0 N·m (0.70 kgf·m, 62 in·lb)**

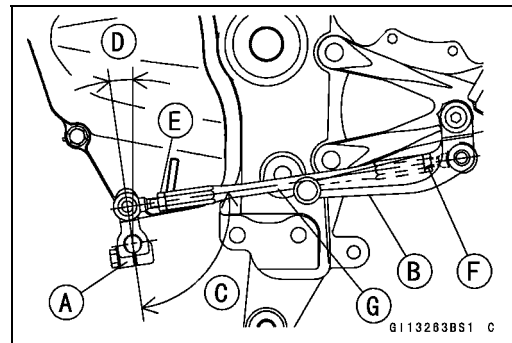

External Shift Mechanism Removal

- Remove:
 - Shift Pedal (see Shift Pedal Removal)
 - Clutch (see Clutch Removal in the Clutch chapter)
 - Oil Pan (see Oil Pan Removal in the Engine Lubrication System chapter)
 - Snap Ring [A]

Special Tool - Outside Circlip Pliers: 57001-144

- Remove the shift shaft assembly and spacers [B] while pulling out the shift mechanism arm [C].

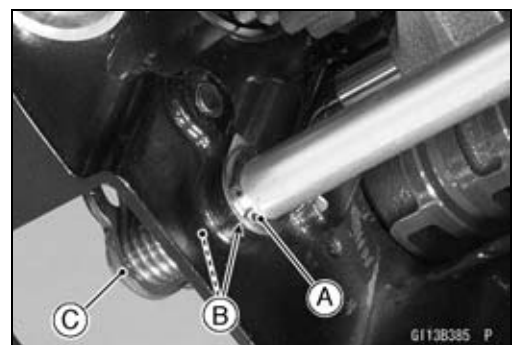

Transmission

- Remove:
 - Gear Positioning Lever Bolt [A]
 - Gear Positioning Lever [B]
 - Washer and Spring

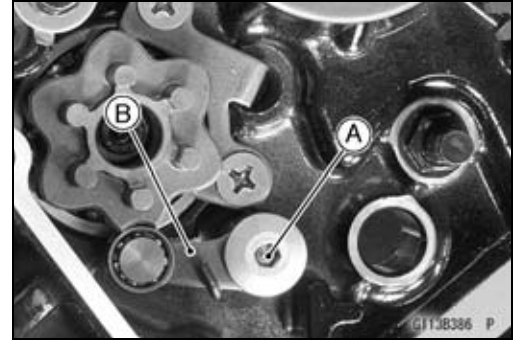

External Shift Mechanism Installation

- Install the gear positioning lever [A] as shown.
 - Spring [B]
 - Washer [C]
 - Bolt [D]
- Tighten:
 - Torque - Gear Positioning Lever Bolt: 12 N·m (1.2 kgf·m, 106 in·lb)**

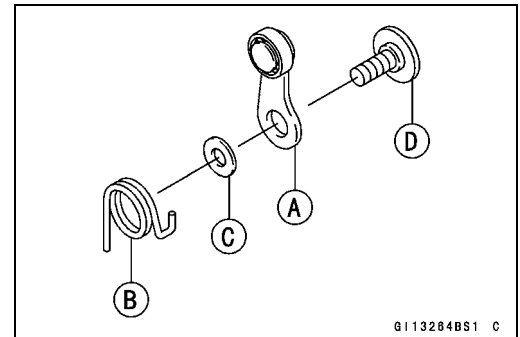

External Shift Mechanism Inspection

- Examine the shift shaft [A] for any damage.
 - ★ If the shaft is bent, straighten or replace it.
 - ★ If the serration [B] are damaged, replace the shaft.
 - ★ If the springs [C] are damaged in any way, replace them.
 - ★ If the shift mechanism arm [D] is damaged in any way, replace the shaft.

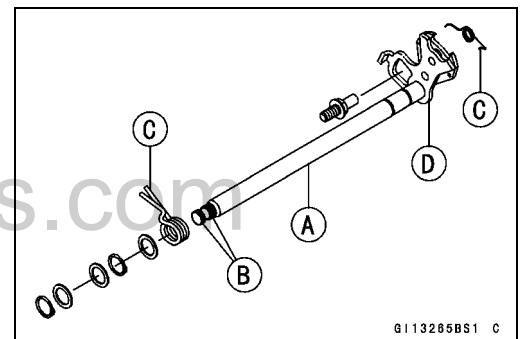

- Check the return spring pin [A] is not loose.
 - ★ If it is loose, unscrew it, apply a non-permanent locking agent to the threads, and tighten it.

Torque - Shift Shaft Return Spring Pin: 29 N·m (3.0 kgf·m, 21 ft·lb)

- Check the gear positioning lever [B] and its spring for breaks or distortion.
 - ★ If the lever or spring are damaged in any way, replace them.
- Visually inspect the shift drum cam [C].
 - ★ If they are badly worn or if they show any damage, replace it.

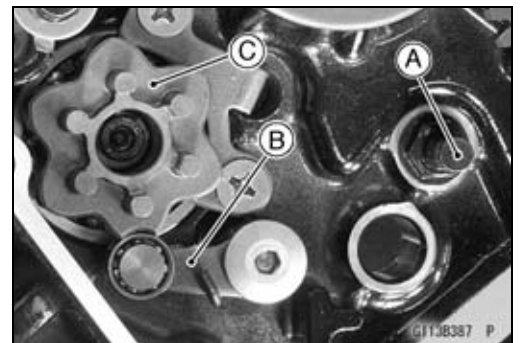

Transmission

Transmission Shaft Removal

- Split the crankcase (see Crankcase Splitting).
- Remove the output shaft [A].
- Discard the oil seal [B]

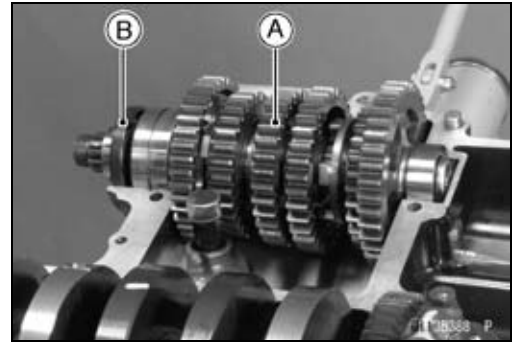

- Remove:
 - Water Pump (see Water Pump Removal in the Cooling System chapter)
 - Shift Forks (see Shift Drum and Shift Forks Removal)
 - Bolts [A]
 - Drive Shaft Cover [B]
- Pull out the drive shaft [C].

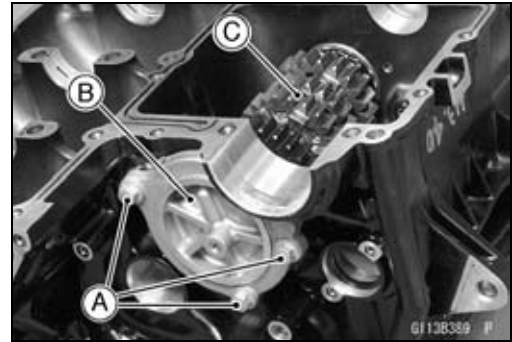

Transmission Shaft Installation

- Check to see that the set pin [A] and set ring [B] are in place.
- Install the output shaft into the upper crankcase half.
- Apply engine oil to the sliding surface of the gears and bearings.
- The bearing set pin and ring must match properly with the hole or groove in the bearing outer races. When they are properly matched, there is no clearance between the crankcase and the bearing outer races.
- When the new ball bearing [A] is installed in the drive shaft cover [B], press and insert the new ball bearing so that seal surface side [C] faces to drive shaft cover.

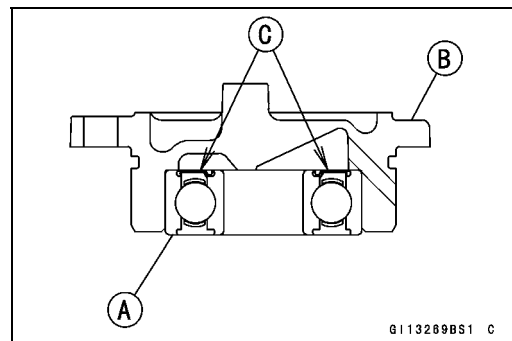
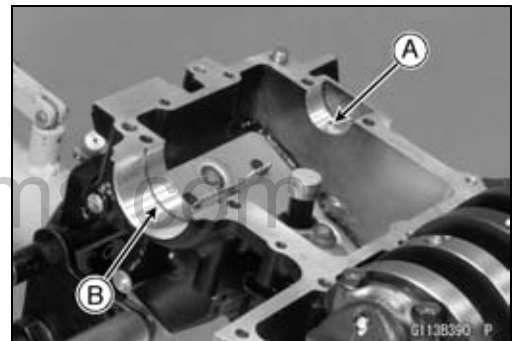

- Apply engine oil to the sliding surface of the gears and bearings.
- Install the drive shaft into the lower crankcase half.
- Replace the O-ring [A] with a new one.
- Apply grease to the new O-ring.
- Install the dowel pin [B].
- Fit the pin of the crankcase into the hole [C] in the drive shaft cover [D].
- Tighten:

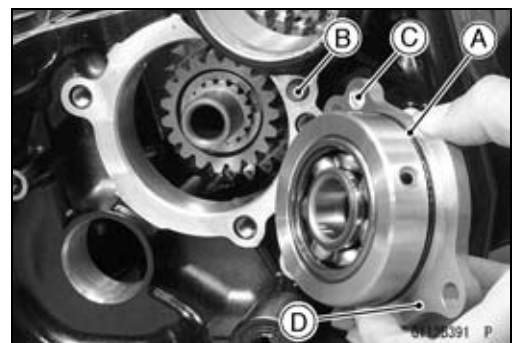

Torque - Drive Shaft Cover Bolts: 25 N·m (2.5 kgf·m, 18 ft·lb)

Transmission

- Assemble the crankcase (see Crankcase Assembly).
 - Press in the new oil seal [A] onto collar [B] so that the surface of the oil seal is flush with the counterbore bottom surface [C] of the crankcase.
- Apply high-temperature grease to the oil seal lips.

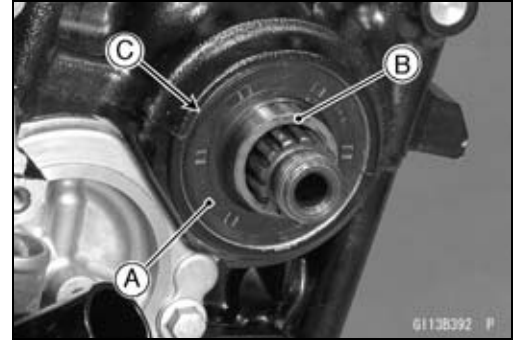

Transmission Shaft Disassembly

- Remove the transmission shafts (see Transmission Shaft Removal).
- Remove the circlips, disassemble the transmission shafts.

Special Tool - Outside Circlip Pliers: 57001-144

- The 5th gear [A] on the output shaft has three steel balls assembled into it for the positive neutral finder mechanism. Remove the 5th gear.
- Set the output shaft in a vertical position holding the 3rd gear [B].
- Spin the 5th gear quickly [C] and pull it off upward.

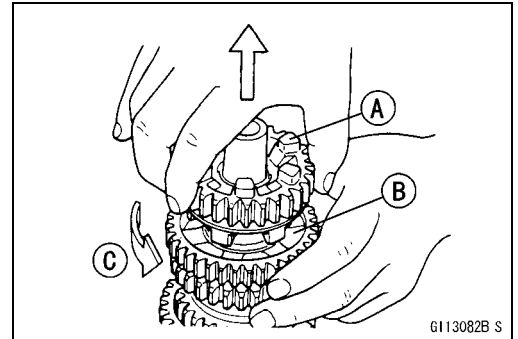

- Remove the ball bearing [A] with collar [B] from the output shaft.

Special Tools - Bearing Puller [C]: 57001-135

Bearing Puller Adapter [D]: 57001-317

- Discard the bearing.

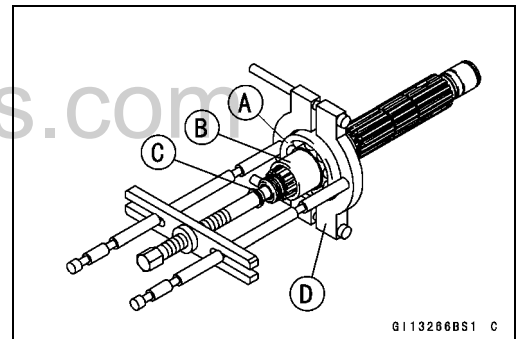

Transmission Shaft Assembly

- Install the new ball bearing [A] and collar [B] on the output shaft, using the bearing driver.

Special Tool - Bearing Driver, $\phi 32$: 57001-382

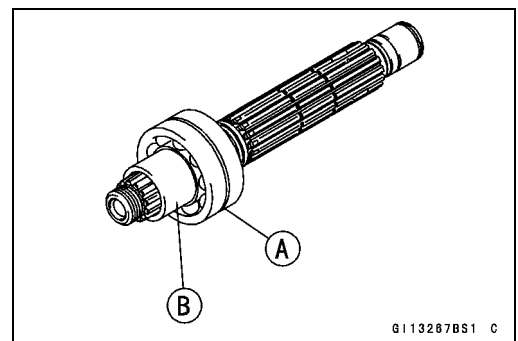

Transmission

- Apply engine oil to the bushings, ball bearings and shafts.
- Install the gear bushings [A] on the shaft with their holes [B] aligned.

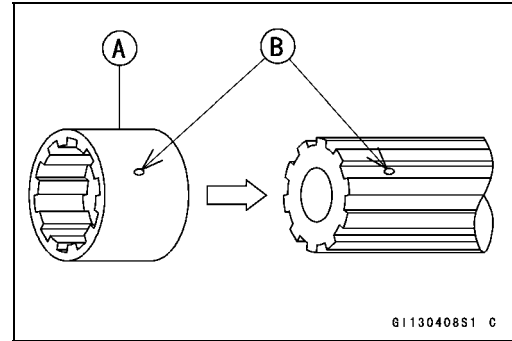

- Replace any circlips removed with new ones.
- Install the circlips [A] so that the opening [B] of it is aligned with spline grooves [C].
- Install the circlips so that the mark [D] on them faces to each gear side.

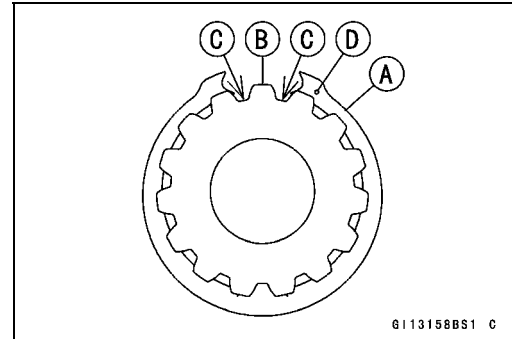

- The drive shaft gears can be recognized by size: the gear with the smallest diameter is 1st gear, and the largest one is 6th gear. Be sure that all parts are put back in the correct sequence and all circlips and washers are properly in place.
- Install the 3rd/4th gear onto the drive shaft with their oil holes aligned.
- Install the 6th gear bushing onto the drive shaft with their oil holes aligned.
- The output shaft gears can be recognized by size: the gear with the largest diameter is 1st gear, and the smallest one is 6th gear. Be sure that all parts are put back in the correct sequence and all circlips and washers are properly in place.
- Install the 5th and 6th gears onto the output shaft with their oil holes aligned.
- Install the 3rd/4th gear bushings onto the output shaft with their oil holes aligned.

www.zxforums.com

Transmission

- Fit the steel balls into the 5th gear holes in the output shaft, aligning three oil holes [D].
5th Gear [A]
Output Shaft [B]
Steel Balls [C]

CAUTION

Do not apply grease to the balls to hold them in place. This will cause the positive neutral finder mechanism to malfunction.

- After assembling the 5th gear with steel balls in place on the output shaft, check the ball-locking effect that the 5th gear doesn't come out of the output shaft when moving it up and down by hand.
- Check that each gear spins or slides freely on the transmission shafts without binding after assembly.

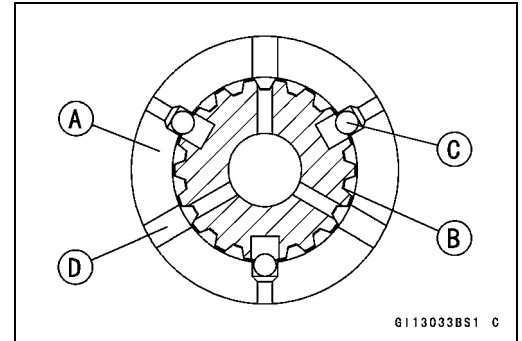

www.zxforums.com

Transmission

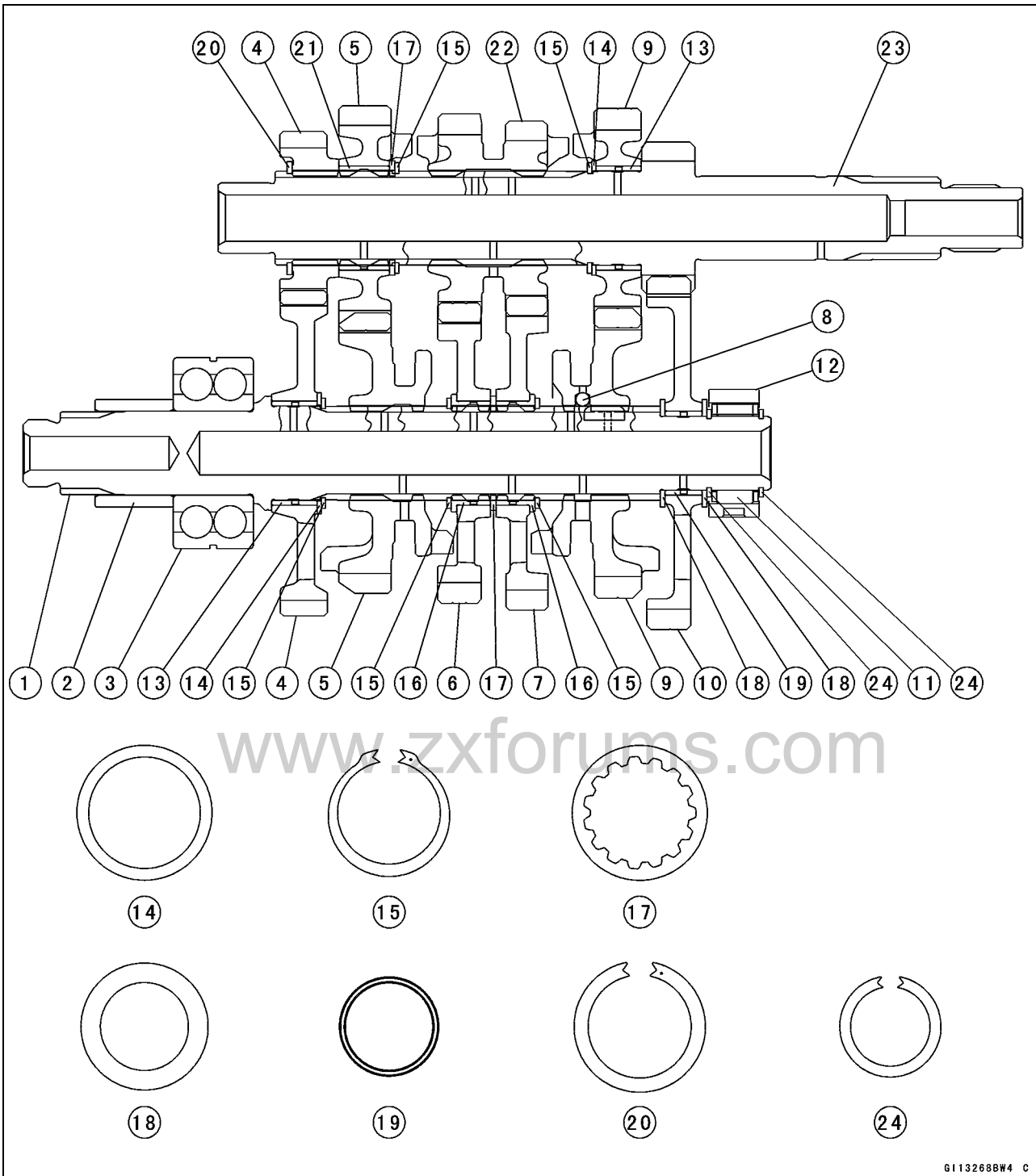

G113268B#4 C

- | | |
|------------------------|---|
| 1. Output Shaft | 13. Bushing |
| 2. Collar | 14. Thrust Washer, $\phi 34$ mm (1.34 in.) |
| 3. Ball Bearing | 15. Snap Ring |
| 4. 2nd Gear | 16. Bushing |
| 5. 6th (Top) Gear | 17. Toothed Washer, $\phi 34$ mm (1.34 in.) |
| 6. 4th Gear | 18. Thrust Washer, $\phi 32$ mm (1.26 in.) |
| 7. 3rd Gear | 19. Bushing |
| 8. Steel Ball | 20. Snap Ring |
| 9. 5th Gear | 21. Bushing |
| 10. 1st Gear | 22. 3rd/4th Gear |
| 11. Needle Bearing | 23. Drive Shaft |
| 12. Bearing Outer Race | 24. Snap Ring |

Transmission

Shift Drum and Fork Removal

- Split the crankcase (see Crankcase Splitting).
- Remove:
 - Gear Position Switch (see Gear Position Switch Removal in the Electrical System chapter)
 - Bolt [A]
 - Shift Fork Holder [B]
 - Screws [C]
 - Shift Drum Bearing Holder [D]

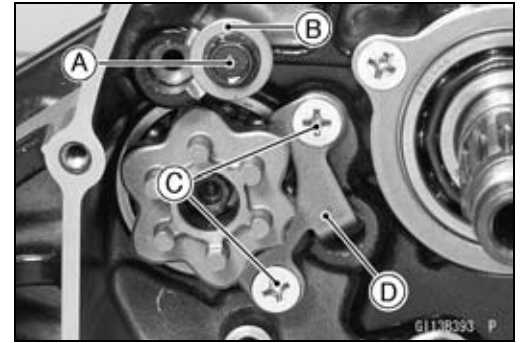

- Pull out the shift rods [A], and take off the shift forks [B].
- Pull out the shift drum [C].

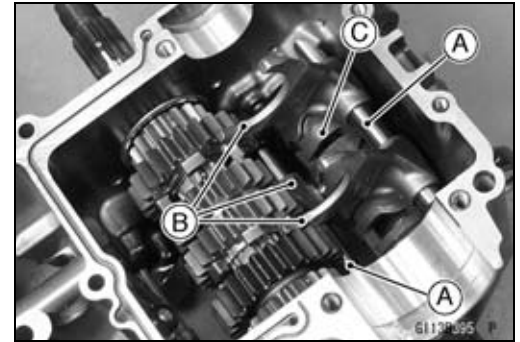

Shift Drum and Fork Installation

- Apply engine oil to the shift drum, forks and rods.
- Install the shift rods [A], noting the groove position.
- Position the one with shortest ears [B] on the drive shaft and place the pin in the center groove in the shift drum [C].
- The two forks [D] on the output shaft are identical.
- Install the forks as shown.
- Apply a non-permanent locking agent to the threads of the shift drum bearing holder screws and shift fork holder bolt, and tighten them.

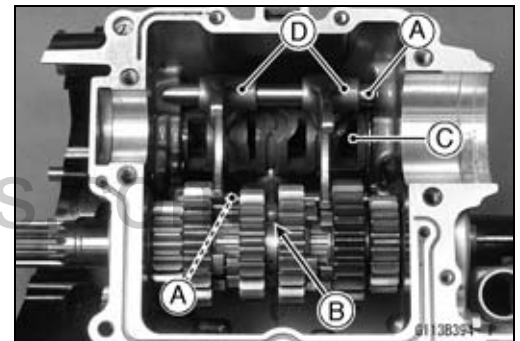

Torque - Shift Fork Holder Bolt: 12 N·m (1.2 kgf·m, 106 in·lb)

Shift Drum Bearing Holder Screws: 5.0 N·m (0.50 kgf·m, 44 in·lb)

Shift Drum Disassembly

- Remove the shift drum (see Shift Drum and Fork Removal).
- While holding the shift drum with a vise, remove the shift drum cam holder bolt.
 - Shift Drum Cam Holder Bolt [A]
 - Dowel Pin [B]

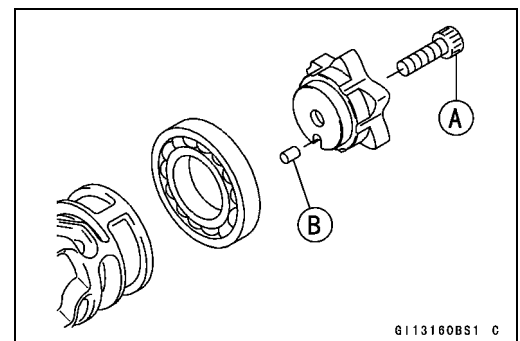

Shift Drum Assembly

- Be sure to install the dowel pin.
- Apply a non-permanent locking agent to the threads of the shift drum cam holder bolt, and tighten it.

Torque - Shift Drum Cam Holder Bolt: 12 N·m (1.2 kgf·m, 104 in·lb)

Transmission

Shift Fork Bending

- Visually inspect the shift forks, and replace any fork that is bent. A bent fork could cause difficulty in shifting, or allow the transmission to jump out of gear when under power. 90° [A]

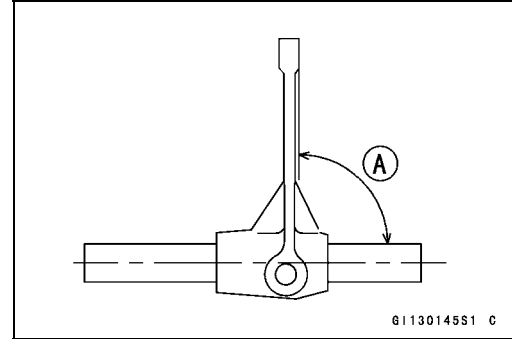

Shift Fork/Gear Groove Wear

- Measure the thickness of the shift fork ears [A], and measure the width [B] of the gear grooves.
- ★ If the thickness of a shift fork ear is less than the service limit, the shift fork must be replaced.

Shift Fork Ear Thickness

- Standard: 5.9 ~ 6.0 mm (0.232 ~ 0.236 in.)
- Service Limit: 5.8 mm (0.228 in.)

- ★ If the gear groove is worn over the service limit, the gear must be replaced.

Gear Groove Width

- Standard: 6.05 ~ 6.15 mm (0.238 ~ 0.242 in.)
- Service Limit: 6.25 mm (0.246 in.)

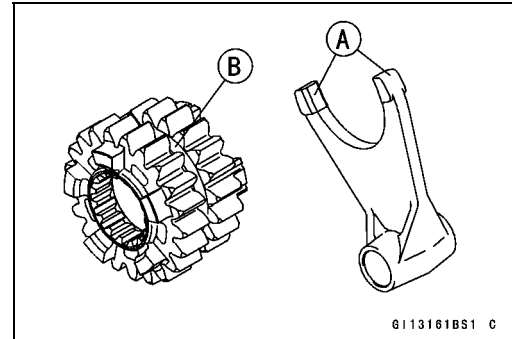

Shift Fork Guide Pin/Drum Groove Wear

- Measure the diameter of each shift fork guide pin [A], and measure the width [B] of each shift drum groove.
- ★ If the guide pin on any shift fork is less than the service limit, the fork must be replaced.

Shift Fork Guide Pin Diameter

- Standard: 5.9 ~ 6.0 mm (0.232 ~ 0.236 in.)
- Service Limit: 5.8 mm (0.228 in.)

- ★ If any shift drum groove is worn over the service limit, the drum must be replaced.

Shift Drum Groove Width

- Standard: 6.05 ~ 6.20 mm (0.238 ~ 0.244 in.)
- Service Limit: 6.3 mm (0.248 in.)

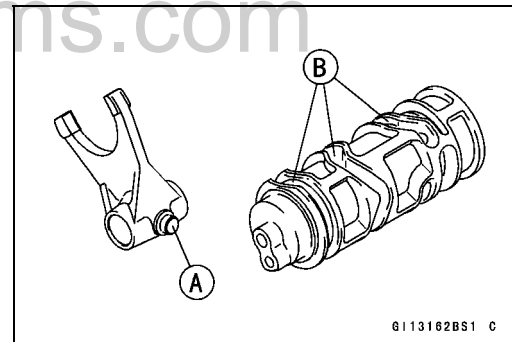

Gear Dog and Gear Dog Hole Damage

- Visually inspect the gear dogs [A] and gear dog holes [B].
- ★ Replace any damaged gears or gears with excessively worn dogs or dog holes.

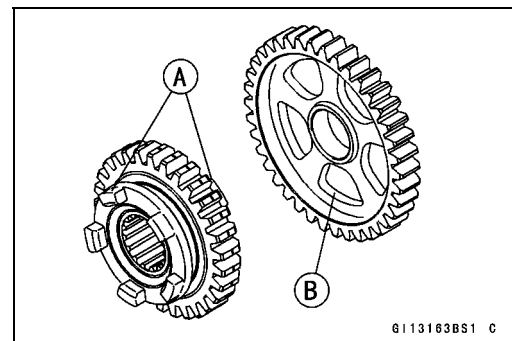

Wheels/Tires

Table of Contents

Exploded View	10-2
Specifications	10-4
Special Tools	10-5
Wheels (Rims)	10-6
Front Wheel Removal	10-6
Front Wheel Installation	10-6
Rear Wheel Removal	10-8
Rear Wheel Installation	10-8
Wheel Inspection	10-10
Axle Inspection	10-10
Balance Inspection	10-11
Balance Adjustment	10-11
Balance Weight Removal	10-11
Balance Weight Installation	10-11
Tires	10-13
Air Pressure Inspection/Adjustment	10-13
Tire Inspection	10-13
Tire Removal	10-13
Tire Installation	10-13
Tire Repair	10-15
Hub Bearing	10-16
Hub Bearing Removal	10-16
Hub Bearing Installation	10-16
Hub Bearing Inspection	10-16
Hub Bearing Lubrication	10-17

Exploded View

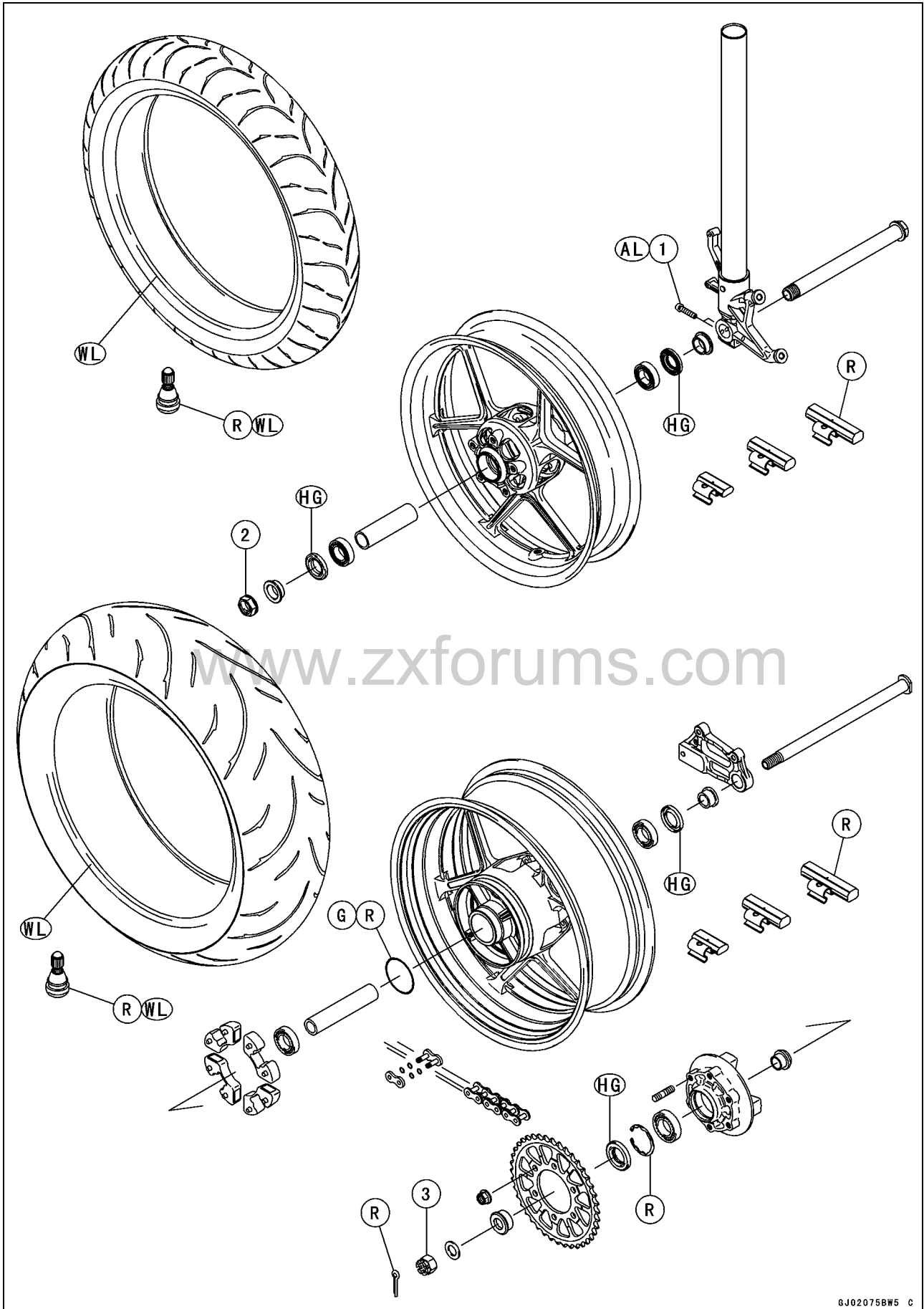

Exploded View

No.	Fastener	Torque			Remarks
		N·m	kgf·m	ft·lb	
1	Front Axle Clamp Bolts	20	2.0	15	AL
2	Front Axle Nut	127	13.0	94	
3	Rear Axle Nut	108	11.0	80	

AL: Tighten the two clamp bolts alternately two times to ensure even tightening.

G: Apply grease.

HG: Apply high-temperature grease.

R: Replacement Parts

WL: Apply soap and water solution or rubber lubricant.

www.zxforums.com

Specifications

Item	Standard	Service Limit
Wheels (Rims)		
Rim Runout:		
Axial	TIR 0.5 mm (0.02 in.) or less	TIR 1.0 mm (0.04 in.)
Radial	TIR 0.8 mm (0.03 in.) or less	TIR 1.0 mm (0.04 in.)
Axle Runout/100 mm	TIR 0.03 mm (0.0012 in.) or less	TIR 0.2 mm (0.01 in.)
Wheel Balance	10 g (0.35 oz.) or less	— — —
Balance Weights	10 g (0.35 oz.), 20 g (0.71 oz.), 30 g (1.06 oz.)	— — —
Rim Size:		
Front	17 × 3.50	— — —
Rear	17 × 6.00	— — —
Tires		
Air Pressure (When Cold):		
Front	Up to 180 kg (397 lb) load: 250 kPa (2.50 kgf/cm ² , 36 psi)	— — —
Rear	Up to 180 kg (397 lb) load: 290 kPa (2.90 kgf/cm ² , 42 psi)	— — —
Tread Depth:		
Front	6.0 mm (0.24 in.)	1 mm (0.04 in.) (AT, CH, DE) 1.6 mm (0.06 in.)
Rear	6.5 mm (0.26 in.)	Up to 130 km/h (80 mph): 2 mm (0.08 in.) Over 130 km/h (80 mph): 3 mm (0.12 in.)
Standard Tires:	Make, Type	Size
Front	DUNLOP, SPORTMAX RADIAL D209FMTJ	120/70 ZR17 M/C (58 W)
Rear	DUNLOP, SPORTMAX RADIAL D209J	190/55 ZR17 M/C (75 W)

⚠ WARNING

Use the same manufacturer's tires on both front and rear wheels.

Special Tools

Bearing Driver Set:
57001-1129

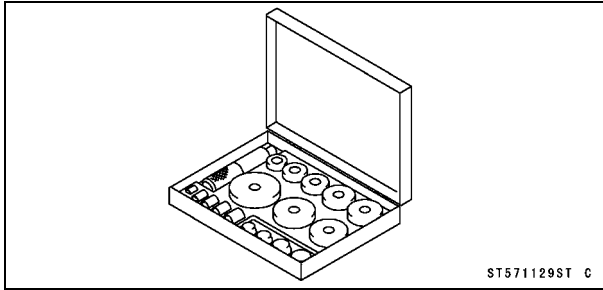

Bearing Remover Shaft, $\phi 13$:
57001-1377

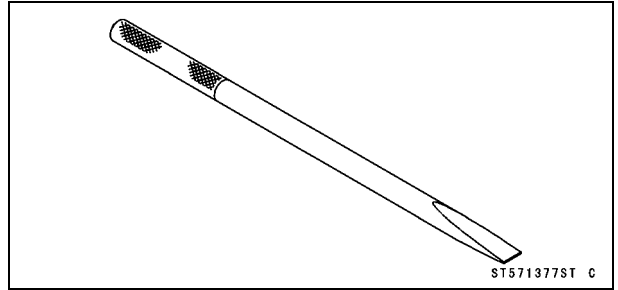

Jack:
57001-1238

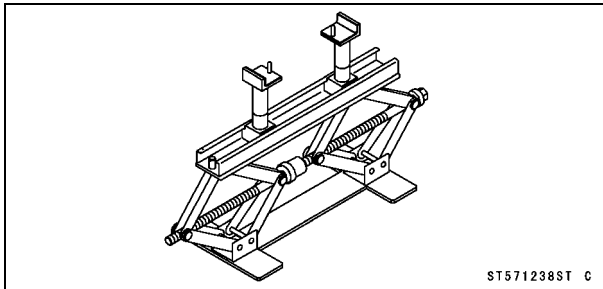

Jack Attachment:
57001-1608

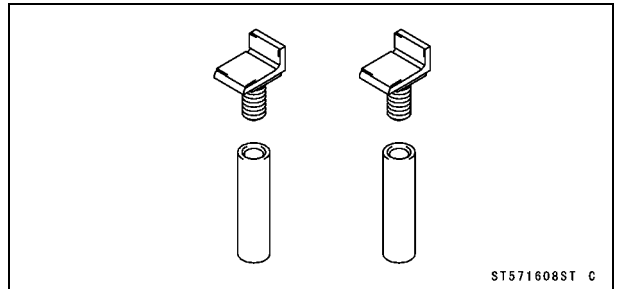

Bearing Remover Head, $\phi 20 \times \phi 22$:
57001-1293

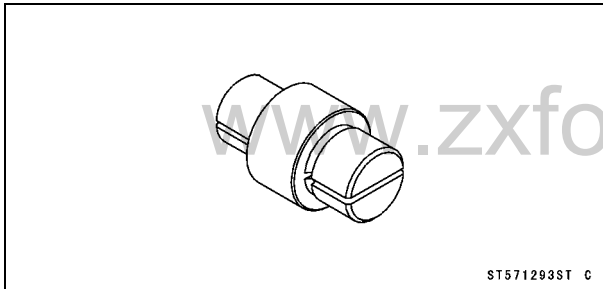

Wheels (Rims)

Front Wheel Removal

- Remove:
 - Brake Caliper Mounting Bolts [A]
 - Front Brake Calipers [B] (Left and Right)

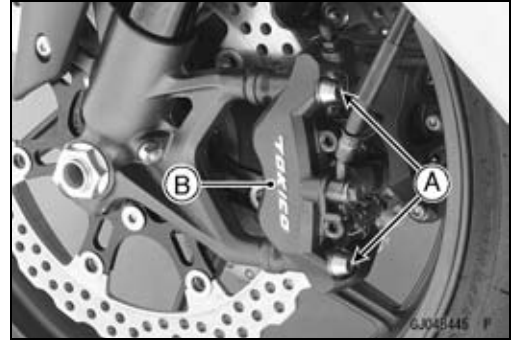

- Loosen:
 - Left Side Axle Clamp Bolts [A]
 - Axle Nut [B]
 - Right Side Axle Clamp Bolts

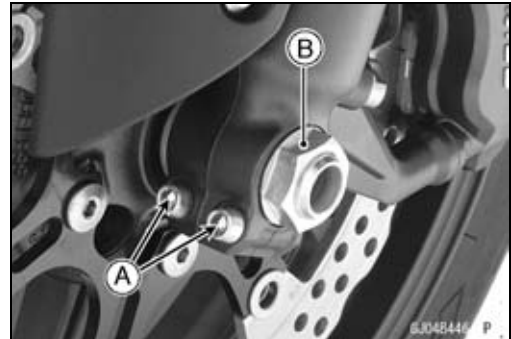

- Remove the lower fairings (see Lower Fairing Removal in the Frame chapter).
- Raise the front wheel off the ground with the jack [A].
 - Special Tools - Jack: 57001-1238**
 - Jack Attachment: 57001-1608**
- Remove the axle nut and pull out the axle to the right and drop the front wheel out of the forks.



CAUTION

Do not lay the wheel down on one of the discs. This can damage or warp the disc. Place blocks under the wheel so that the disc does not touch the ground.

Front Wheel Installation

NOTE

○The direction of the wheel rotation [A] is shown by an arrow [B] on the wheel spoke.

- Check the wheel rotation mark on the front wheel and install it.

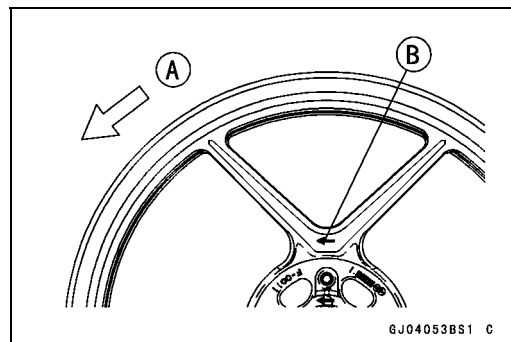

Wheels (Rims)

- Apply high-temperature grease to the grease seal lips.
- Fit the collars [A] on the both sides of the hub.
- The collars are identical.
- Insert the axle.
- Tighten the axle nut [B].
- Right Axle Clamp Bolts [C]
- Left Axle Clamp Bolts [D]
- 0.7 ~ 4.1 mm (0.028 ~ 0.161 in.) [E]
- Viewed from Rear [F]

Torque - Front Axle Nut: 127 N·m (13.0 kgf·m, 94 ft·lb)

- Before tightening the axle clamp bolts on the right front fork leg, pump the front fork up and down [A] 4 or 5 times to allow all on the right front fork leg to seat on the front axle.

NOTE

- Put a block in front of the front wheel to stop moving.
- Tighten the two clamp bolts alternately two times to ensure even tightening torque.
- Tighten the axle clamp bolts on the right fork leg first. Next, tighten the left axle clamp bolts.

Torque - Front Axle Clamp Bolts: 20 N·m (2.0 kgf·m, 15 ft·lb)

NOTE

- Tighten the two clamp bolts alternately two times to ensure even tightening torque.
- Check the clearance [A] between the front axle nut [B] and the left fork leg [C]. The clearance between the front axle nut and the left fork leg should be between 0.7 ~ 4.1 mm (0.028 ~ 0.161 in.).
- ★ If the between clearance is out of this range, remove the front wheel again and check the axle, wheel hub, and other related parts for damage.

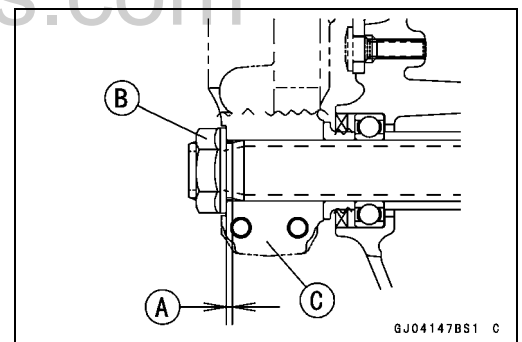
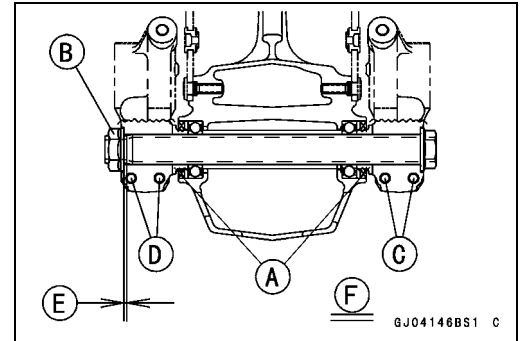

- Install the front brake calipers (see Caliper Installation in the Brakes chapter).
- Check the front brake effectiveness (see Brake Operation Inspection in the Periodic Maintenance chapter).

⚠ WARNING

Do not attempt to drive the motorcycle until a full brake lever is obtained by pumping the brake lever until the pads are against the disc. The brake will not function on the first application of the lever if this is not done.

Wheels (Rims)

Rear Wheel Removal

- Raise the rear wheel off the ground with the stand [A].

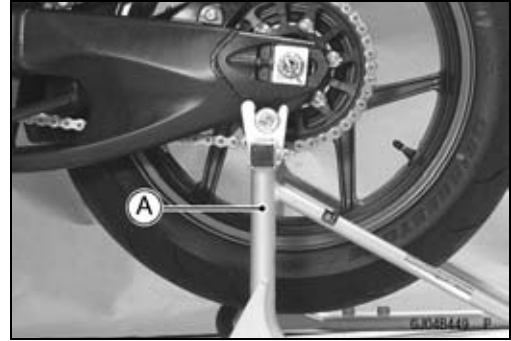

- Remove:
Rear Caliper Mounting Bolts [A]
Rear Caliper [B]

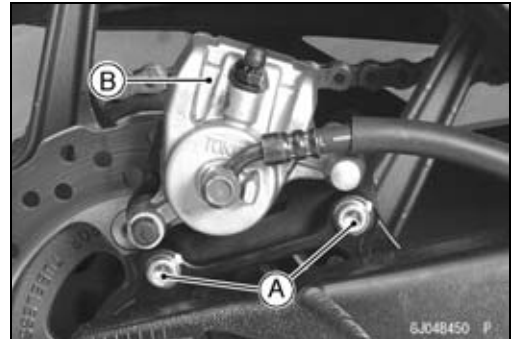

- Remove:
Cotter Pin [A]
Axle Nut [B]
Axle [C] (from Right Side)

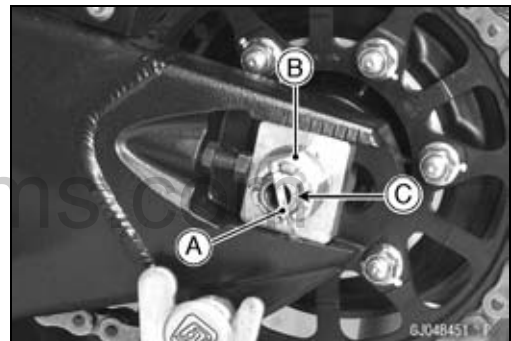

- Remove the drive chain [A] from the rear sprocket toward the left.
- Move the rear wheel back and remove it.

www.zxforums.com

CAUTION

Do not lay the wheel on the ground with the disc facing down. This can damage or warp the disc. Place blocks under the wheel so that the disc does not touch the ground.



Rear Wheel Installation

- Apply high-temperature grease to the grease seal lips.
- Fit the collars [A] on the both sides of the hub.

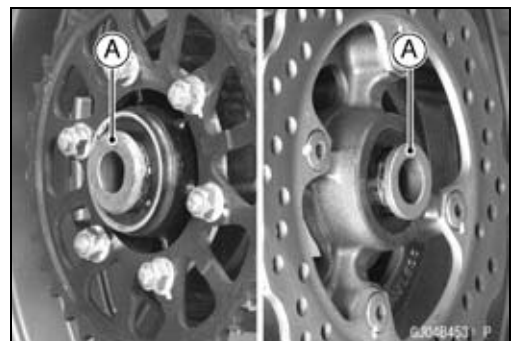

Wheels (Rims)

- If the coupling [A] is removed from the rear wheel, apply the grease [B] as shown.
- Wheel Flange Portion [C]
- O-ring [D]

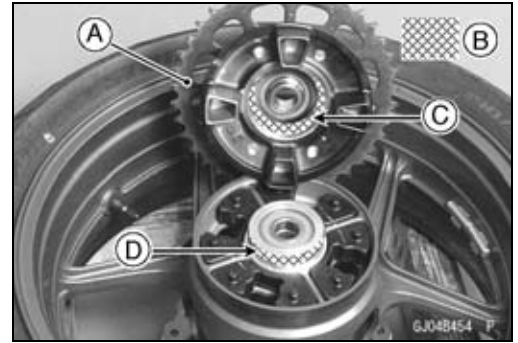

- Engage the drive chain with the rear sprocket.
- Install the caliper bracket [A] onto the swingarm stop [B].
- Insert the axle from the right side of the wheel, and tighten the axle nut.

Torque - Rear Axle Nut: 108 N·m (11.0 kgf·m, 80 ft·lb)

- Adjust the drive chain slack after installation (see Drive Chain Slack Inspection in the Periodic Maintenance chapter).

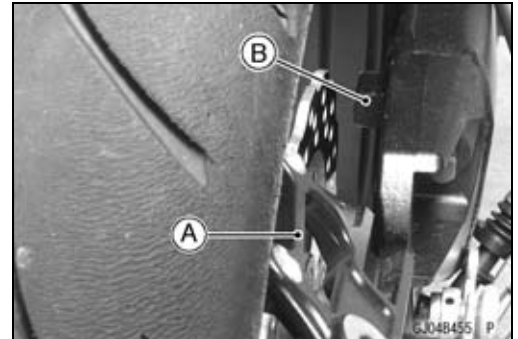

- Insert a new cotter pin [A].

NOTE

- When inserting the cotter pin, if the slots in the nut do not align with the cotter pin hole in the axle, tighten the nut clockwise [B] up to next alignment.
- It should be within 30 degree.
- Loosen once and tighten again when the slot goes past the nearest hole.

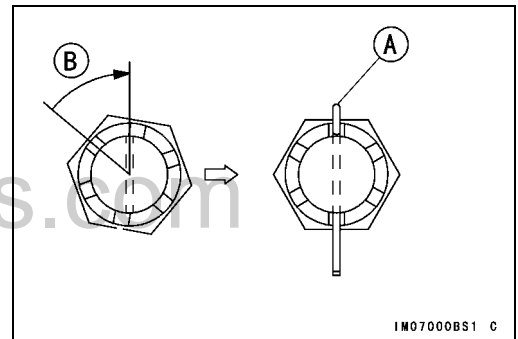

- Bend the cotter pin [A] over the nut.

⚠ WARNING

If the rear axle nut is not securely tightened or the cotter pin is not installed, an unsafe riding condition may result.

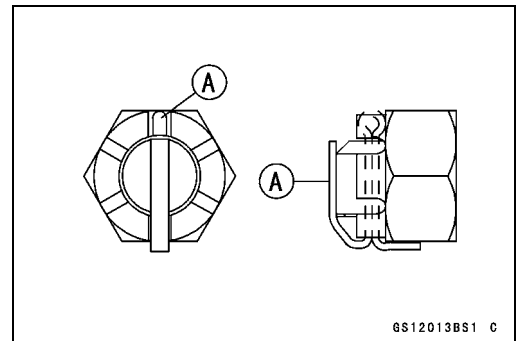

- Install the rear brake caliper (see Caliper Installation in the Brakes chapter).
- Check the rear brake effectiveness (see Brake Operation Inspection in the Periodic Maintenance chapter).

⚠ WARNING

Do not attempt to drive the motorcycle until a full brake pedal is obtained by pumping the brake pedal until the pads are against the disc. The brake will not function on the first application of the pedal if this is not done.

Wheels (Rims)

Wheel Inspection

- Raise the front/rear wheel off the ground.

Special Tools - Jack: 57001-1238

Jack Attachment: 57001-1608

- Spin the wheel lightly, and check for roughness or binding.
- ★ If roughness or binding is found, replace the hub bearings.
- Inspect the wheel for small cracks, dents, bending, or warp.
- ★ If there is any damage to the wheel, replace the wheel.
- Remove the wheel, and support it with the tire by the axle.
- Measure the rim runout, axial [A] and radial [B], with a dial gauge.
- ★ If rim runout exceeds the service limit, check the hub bearings.
- ★ If the problem is not due to the bearings, replace the wheel.

Rim Runout (with tire installed)

Standard:

Axial TIR 0.5 mm (0.02 in.) or less

Radial TIR 0.8 mm (0.03 in.) or less

Service Limit:

Axial TIR 1.0 mm (0.04 in.)

Radial TIR 1.0 mm (0.04 in.)

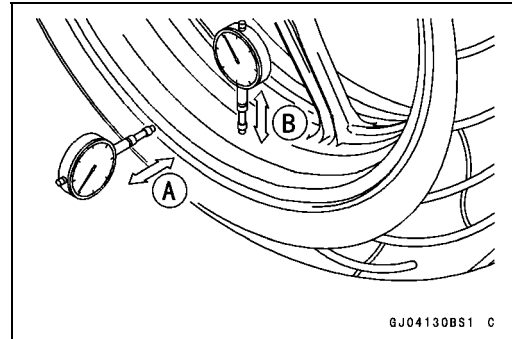

⚠ WARNING

Never attempt to repair a damaged wheel. If there is any damage besides wheel bearings, the wheel must be replaced to insure safe operational condition.

Axle Inspection

- Remove the front and rear axles.
- Visually inspect the front and rear axle for damages.
- ★ If the axle is damaged or bent, replace it.
- Place the axle in V blocks that are 100 mm (3.94 in.) [A] apart, and set a dial gauge [B] on the axle at a point halfway between the blocks. Turn [C] the axle to measure the runout. The difference between the highest and lowest dial readings is the amount of runout.
- ★ If axle runout exceeds the service limit, replace the axle.

Axle Runout/100 mm (3.94 in.)

Standard: TIR 0.03 mm (0.0012 in.) or less

Service Limit: TIR 0.2 mm (0.01 in.)

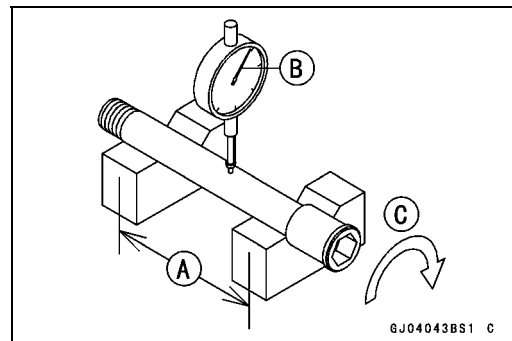

Wheels (Rims)

Balance Inspection

- Remove the wheel (see wheels (Rims) section).
- Support the wheel so that it can be spun freely.
- Spin the wheel lightly, and mark [A] the wheel at the top when the wheel stops.
- Repeat this procedure several times. If the wheel stops of its own accord in various positions, it is well balanced.
- ★ If the wheel always stops in one position, adjust the wheel balance.

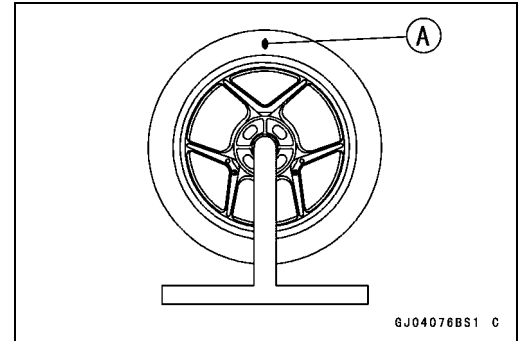

Balance Adjustment

- If the wheel always stops in one position, provisionally attach a balance weight [A] on the rim at the marking using adhesive tape.
- Rotate the wheel 1/4 turn [B], and see whether or not the wheel stops in this position. If it does, the correct balance weight is being used.
- ★ If the wheel rotates and the weight goes up, replace the weight with the next heavier size. If the wheel rotates and the weight goes down, replace the weight with the next lighter size. Repeat these steps until the wheel remains at rest after being rotated 1/4 turn.
- Rotate the wheel another 1/4 turn and then another 1/4 turn to see if the wheel is correctly balanced.
- Repeat the entire procedure as many times as necessary to achieve correct wheel balance.
- Permanently install the balance weight.

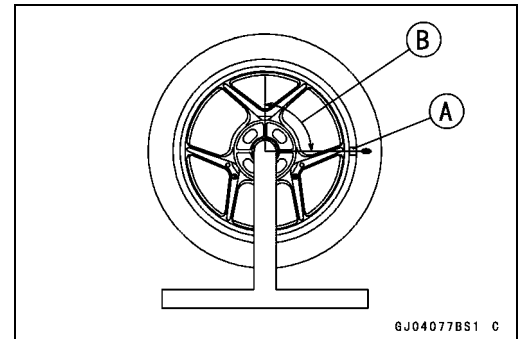

Balance Weight Removal

- Insert a regular tip screwdrivers [A] [B] between the rib [C] and weight [D] as shown.
- Pry the balance weight with two screwdrivers and remove the balance weight.
- Discard the used balance weight.

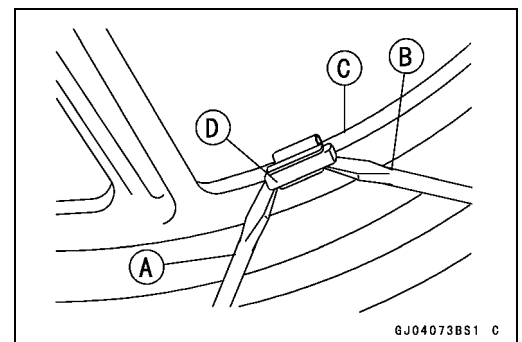

CAUTION

Do not tap the screwdrivers. The rim could be damaged.

Balance Weight Installation

- Check if the weight portion has any play on the blade [A] and clip [B].
- ★ If it does, discard it.

⚠ WARNING

If the balance weight has any play on the rib of the rim, the blade and/or clip have been stretched. Replace the loose balance weight. Do not reuse used balance weight. Unbalanced wheels can create an unsafe riding condition.

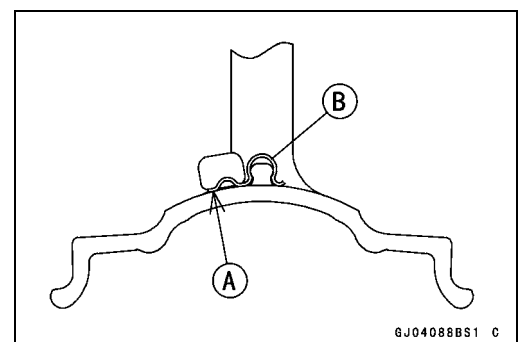

Wheels (Rims)

Balance Weight

Part Number	Weight
41075-0007	10 g (0.35 oz.)
41075-0008	20 g (0.71 oz.)
41075-0009	30 g (1.06 oz.)

NOTE

- Balance weights are available from Kawasaki dealers in 10, 20, and 30 gram (0.35 oz., 0.71 oz., and 1.06 oz.) sizes. An imbalance of less than 10 grams (0.35 oz.) will not usually affect running stability.
- Do not use four or more balance weight (more than 90 gram). If the wheel requires an excess balance weight, disassemble the wheel to find the cause.

- Slip the balance weight [A] on to the rib [B], by pushing or lightly hammering [C] the clip [D].
 Left Side [E]
 Right Side [F]

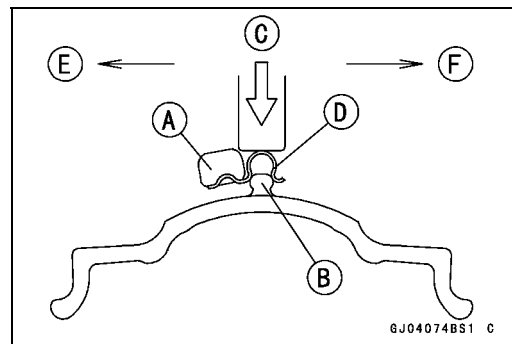

- Be sure to install the balance weight.
- Check that the blade [A] and clip [B] are fully seated on the rim [C] and that the clip is hooked over the rib [D].
 Left Side [E]
 Right Side [F]

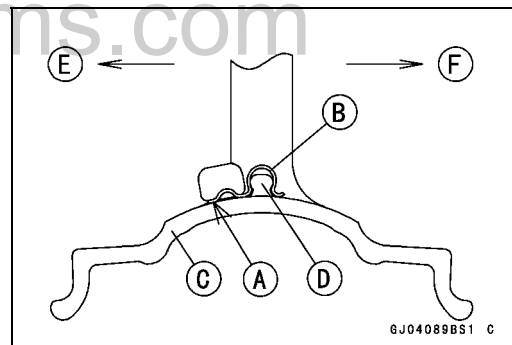

Tires

Air Pressure Inspection/Adjustment

- Refer to the Tires Air Pressure Inspection in the Periodic Maintenance chapter (see Tires Air Pressure Inspection in the Periodic Maintenance chapter).

Tire Inspection

- Refer to the Wheels/Tires Damage Inspection in the Periodic Maintenance chapter (see Wheels/Tires Damage Inspection in the Periodic Maintenance chapter).

Tire Removal

- Remove:
 - Wheel (see wheels (Rims) section)
 - Disc(s)
 - Valve Core (let out the air)
- To maintain wheel balance, mark the valve stem position on the tire with chalk so that the tire can be reinstalled in the same position.
 - Chalk Mark or Yellow Mark [A]
 - Air Valve [B]
 - Align [C]

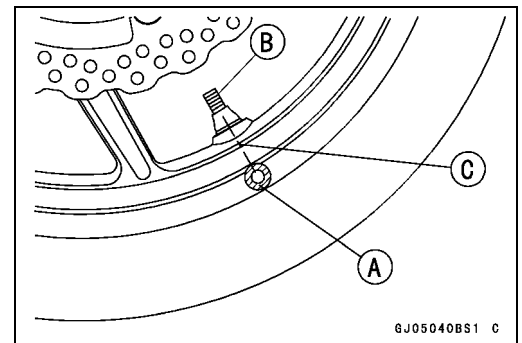

- Lubricate the tire beads and rim flanges on both sides with a soap and water solution or rubber lubricant. This helps the tire beads slip off the rim flanges.

CAUTION

Never lubricate with engine oil or petroleum distillates because they will deteriorate the tire.

- Remove the tire from the rim using a suitable commercially available tire changer.

NOTE

○ *The tires cannot be removed with hand tools because they fit the rims too tightly.*

Tire Installation

⚠ WARNING

Use the same manufacturer's on both front and rear wheels.

- Inspect the rim and tire, and replace them if necessary.
- Clean the sealing surfaces of the rim and tire, and smooth the sealing surfaces of the rim with a fine emery cloth if necessary.
- Remove the air valve and discard it.

CAUTION

Replace the air valve whenever the tire is replaced. Do not reuse the air valve.

Tires

- Install a new valve in the rim.
- Remove the valve cap, lubricate the stem seal [A] with a soap and water solution or rubber lubricant, and pull [B] the valve stem through the rim from the inside out until it snaps into place.

CAUTION

Do not use engine oil or petroleum distillates to lubricate the stem because they will deteriorate the rubber.

- The air valve is shown in the figure.

- Valve Cap [A]
- Valve Core [B]
- Stem Seal [C]
- Valve Stem [D]
- Valve Seat [E]
- Valve Opened [F]

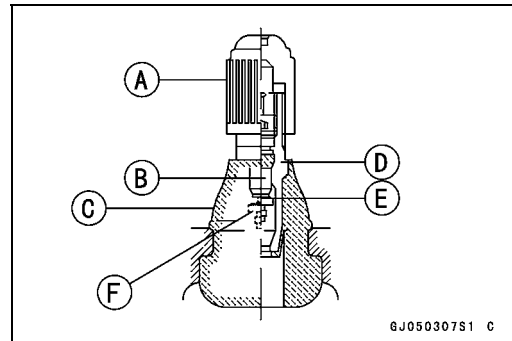
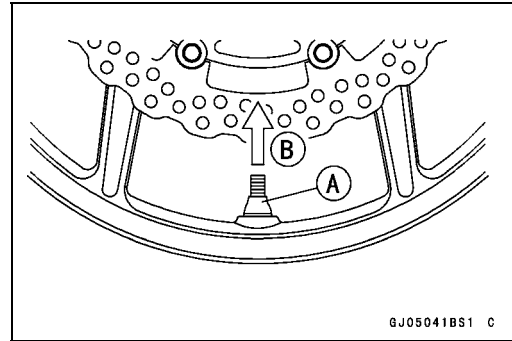

- Apply a soap and water solution, or rubber lubricant to the rim flange and tire beads.
- Check the tire rotation mark on the front and rear tires and install them on the rim accordingly.
- Tire Rotation Mark [A]
- Rotating Direction [B]

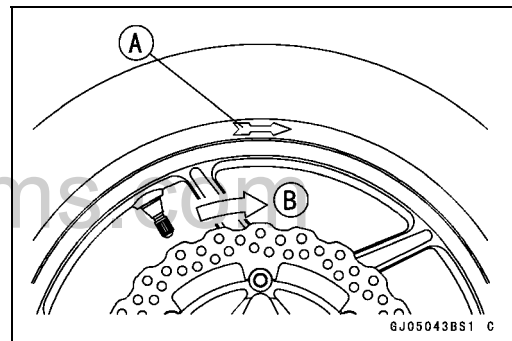

- Position the tire on the rim so that the valve [A] align with the tire balance mark [B] (the chalk mark made during removal, or the yellow paint mark on a new tire).
- Install the tire bead over the rim flange using a suitable commercially available tire changer.
- Lubricate the tire beads and rim flanges with a soap and water solution or rubber lubricant to help seat the tire beads in the sealing surfaces of the rim while inflating the tire.
- Center the rim in the tire beads, and inflate the tire with compressed air until the tire beads seat in the sealing surfaces.

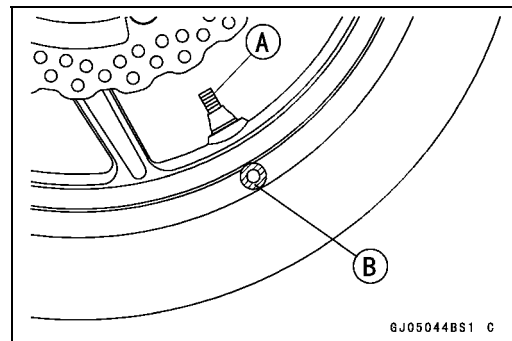

⚠ WARNING

Be sure to install the valve core whenever inflating the tire, and do not inflate the tire to more than 400 kPa (4.0 kgf/cm², 57 psi). Overinflation can explode the tire with possibility of injury and loss of life.

Tires

- Check to see that the rim lines [A] on both sides of the tire sidewalls are parallel with the rim flanges.
- ★ If the rim flanges and tire sidewall rim lines are not parallel, remove the valve core.
- Lubricate the rim flanges and tire beads.
- Install the valve core and inflate the tire again.
- After the tire beads seat in the rim flanges, check for air leakage.
- Inflate the tire slightly above standard inflation.
- Use a soap and water solution or submerge the tire, and check for bubbles that would indicate leakage.
- Adjust the air pressure to the specified pressure (see Tire Inspection).
- Install the air valve cap.
- Install the brake disc(s) so that the marked side faces out (see Brake Disc Installation in the Brakes chapter).
- Adjust the wheel balance (see Balance Adjustment).

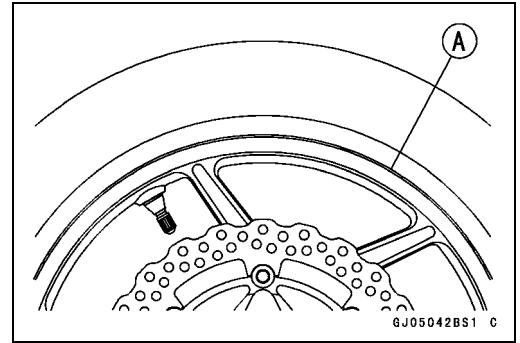

Tire Repair

Currently two types of repair for tubeless tires have come into wide use. One type is called a temporary (external) repair which can be carried out without removing the tire from the rim, and the other type is called permanent (internal) repair which requires tire removal. It is generally understood that higher running durability is obtained by permanent (internal) repairs than by temporary (external) ones. Also, permanent (internal) repairs have the advantage of permitting a thorough examination for secondary damage not visible from external inspection of the tire. For these reasons, Kawasaki does not recommend temporary (external) repair. Only appropriate permanent (internal) repairs are recommended. Repair methods may vary slightly from make to make. Follow the repair methods indicated by the manufacturer of the repair tools and materials so that safe results can be obtained.

Hub Bearing

Hub Bearing Removal

- Remove the wheel, and take out the following.
 - Collars
 - Coupling (out of rear hub)
 - Grease Seals
- Use the bearing remover to remove the hub bearing [A].

CAUTION

Do not lay the wheel on the ground with the disc facing down. This can damage or warp the disc. Place blocks under the wheel so that the disc does not touch the ground.

Special Tools - Bearing Remover Shaft, $\phi 13$ [B]: 57001-1377

Bearing Remover Head, $\phi 20 \times \phi 22$ [C]: 57001-1293

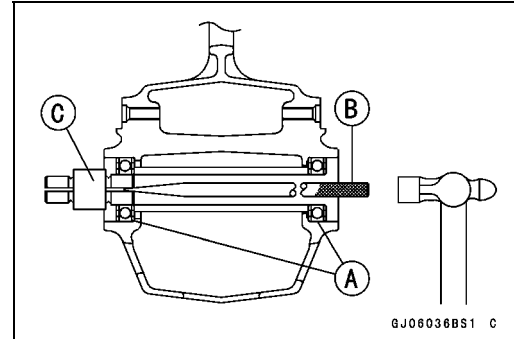

GJ08036BS1 C

Hub Bearing Installation

- Before installing the wheel bearings, blow any dirt or foreign particles out of the hub with compressed air to prevent contamination of the bearings.
- Replace the bearings with new ones.

NOTE

○Install the bearings so that the marked side faces out.

- Install the bearings by using the bearing driver set which does not contact the bearing inner race.
- Press in each right the bearing [A] until they are bottomed.

Special Tool - Bearing Driver Set [B]: 57001-1129

- Replace the grease seals with new ones.
- Press in the grease seals [A] so that the seal surface is flush [B] with the end of the hole.
- Apply high temperature grease to the grease seal lips.

Special Tool - Bearing Driver Set [C]: 57001-1129

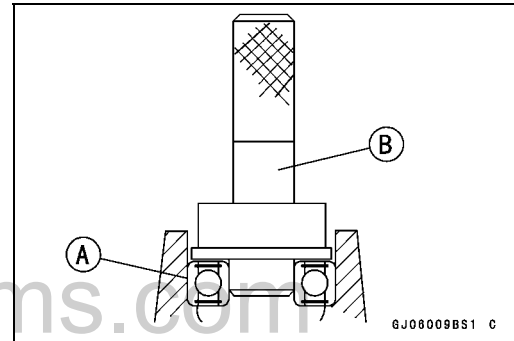

GJ08009BS1 C

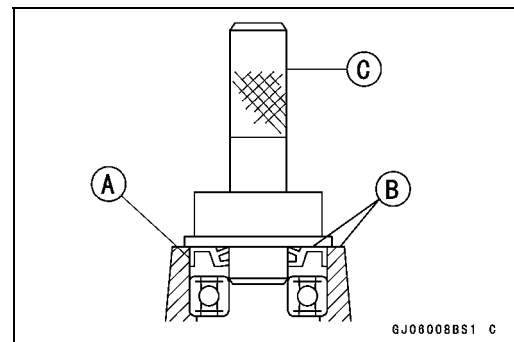

GJ08008BS1 C

Hub Bearing Inspection

Since the hub bearings are made to extremely close tolerances, the clearance can not normally be measured.

NOTE

○Do not remove any bearings for inspection. If any bearings are removed, they will need to be replaced with new ones.

- Turn each bearing in the hub back and forth [A] while checking for plays, roughness, or binding.
- ★If bearing play, roughness, or binding is found, replace the bearing.
- Examine the bearing seal [B] for tears or leakage.
- ★If the seal is torn or is leaking, replace the bearing.

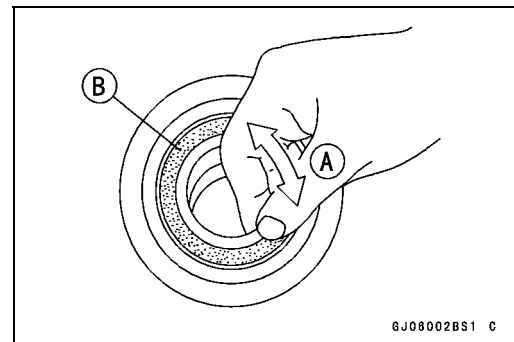

GJ08002BS1 C

Hub Bearing

Hub Bearing Lubrication

NOTE

- *Since the hub bearings are packed with grease and sealed, lubrication is not required.*

www.zxforums.com

www.zxforums.com

Final Drive

Table of Contents

Exploded View	11-2
Specifications	11-4
Special Tools	11-5
Drive Chain.....	11-6
Drive Chain Slack Inspection	11-6
Drive Chain Slack Adjustment	11-6
Wheel Alignment Inspection/Adjustment	11-6
Drive Chain Wear Inspection	11-6
Drive Chain Lubrication.....	11-6
Drive Chain Removal.....	11-6
Drive Chain Installation	11-8
Sprocket, Coupling	11-11
Engine Sprocket Removal	11-11
Engine Sprocket Installation	11-11
Rear Sprocket Removal.....	11-12
Rear Sprocket Installation.....	11-12
Coupling Installation.....	11-13
Coupling Bearing Removal	11-13
Coupling Bearing Installation	11-13
Coupling Bearing Inspection	11-14
Coupling Bearing Lubrication.....	11-14
Coupling Damper Inspection.....	11-14
Sprocket Wear Inspection.....	11-14
Rear Sprocket Warp Inspection	11-15

Exploded View

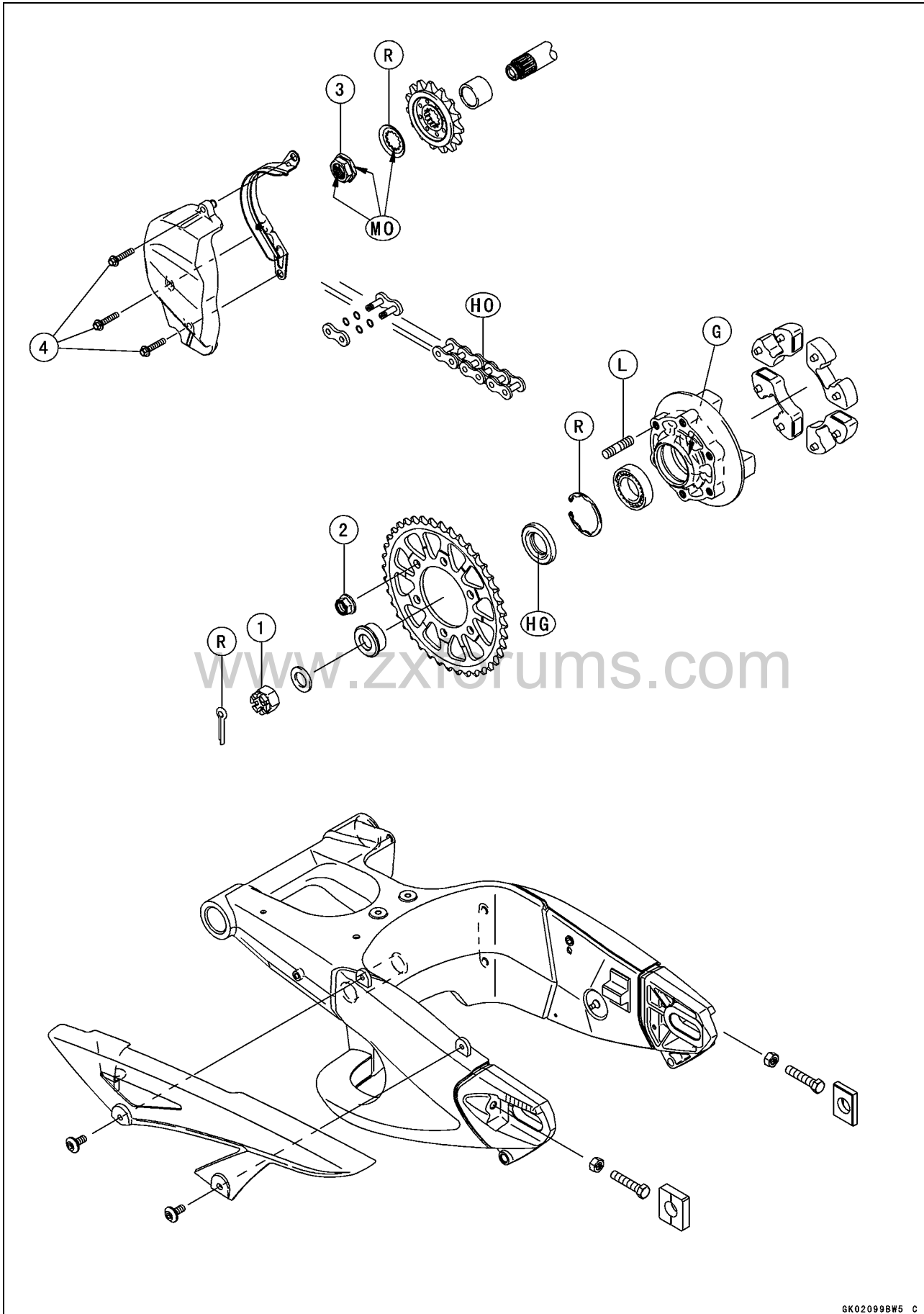

GK02099BW5 C

Exploded View

No.	Fastener	Torque			Remarks
		N·m	kgf·m	ft·lb	
1	Rear Axle Nut	108	11.0	80	
2	Rear Sprocket Nuts	59	6.0	44	
3	Engine Sprocket Nut	125	12.7	92	MO
4	Engine Sprocket Cover Bolts	10	1.0	89 in·lb	

G: Apply grease.

HG: Apply high-temperature grease.

HO: Apply heavy oil.

L: Apply a non-permanent locking agent.

MO: Apply molybdenum disulfide oil solution.

(mixture of engine oil and molybdenum disulfide grease in a weight ratio is 10 : 1)

R: Replacement Parts

www.zxforums.com

Specifications

Item	Standard	Service Limit
Drive Chain		
Drive Chain Slack	30 ~ 35 mm (1.2 ~ 1.4 in.)	— — —
Drive Chain Wear (20-link Length)	317.5 ~ 318.2 mm (12.50 ~ 12.53 in.)	323 mm (12.7 in.)
Standard Chain		
Make	RK EXCEL	— — —
Type	RK 525MFO, Endless	— — —
Link	108 links	— — —
Sprockets		
Rear Sprocket Warp	0.4 mm (0.016 in.) or less	0.5 mm (0.02 in.)

www.zxforums.com

Special Tools

Inside Circlip Pliers:
57001-143

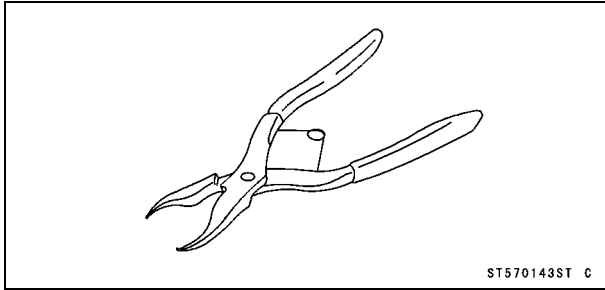

Bearing Driver Set:
57001-1129

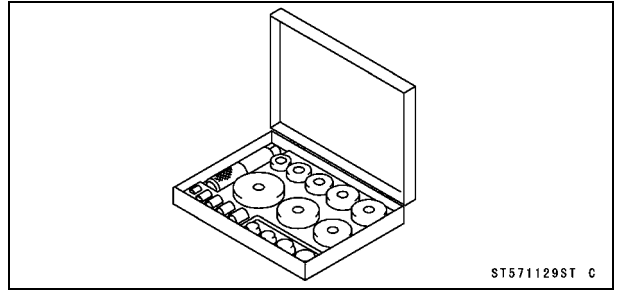

www.zxforums.com

Drive Chain

Drive Chain Slack Inspection

- Refer to the Drive Chain Slack Inspection in the Periodic Maintenance chapter (see Drive Chain Slack Inspection in the Periodic Maintenance chapter).

Drive Chain Slack Adjustment

- Refer to the Drive Chain Slack Inspection in the Periodic Maintenance chapter (see Drive Chain Slack Inspection in the Periodic Maintenance chapter).

Wheel Alignment Inspection/Adjustment

- Refer to the Wheel Alignment Inspection in the Periodic Maintenance chapter (see Wheel Alignment Inspection in the Periodic Maintenance chapter).

Drive Chain Wear Inspection

- Refer to the Drive Chain Wear Inspection in the Periodic Maintenance chapter (see Drive Chain Wear Inspection in the Periodic Maintenance chapter).

Drive Chain Lubrication

- Refer to the Drive Chain Lubrication Condition in the Periodic Maintenance chapter (see Drive Chain Lubrication Condition in the Periodic Maintenance chapter).

Drive Chain Removal

NOTE

- *Since the drive chain is installed through the swingarm, The chain cannot be removed other than by cutting it. Prepare the new link pin, link plate, grease seals, and tools for rejoining the chain.*

- Remove:
Chain Cover [A]
Bolts [B]

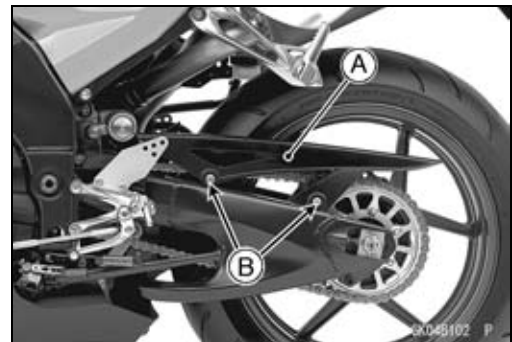

Drive Chain

- Using a suitable tool [A], cut the drive chain by removing the link pins.

Recommended Tool: RK EXCEL 70 Tool (RK-700)

CAUTION
Read the Tool Manual before removing.

- Pressure Bolt (A) [A]
- Pressure Bolt (B) [B]
- Handle Lever [C]
- Pressure Holder [D]
- Guide Plate [E]
- Adjuster Bolt (Yellow) [F]
- Wedge Holder [G] and Wedge Pin
- Grip Handle [H]
- Flare Pin [I]
- Cap [J]
- Adjuster Bolt [K]
- Pin Puller [L]
- Body [N]
- Cap Bolt [M]

- Install the guide plate [A] on the body [B].
- Screw the cap bolt [C].
- Install the grip handle.

www.zxforums.com

- Set the chain [A] to the guide plate [B].
- Screw in the adjuster bolt [C] for holding the chain.
- Screw in the pressure bolt (A) [D] for holding the chain.

- Insert the pin puller [A] to the pressure bolt (B) [B].

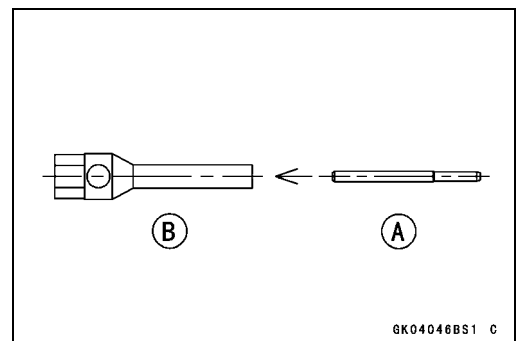
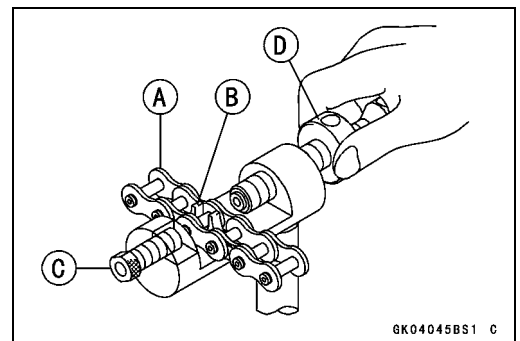
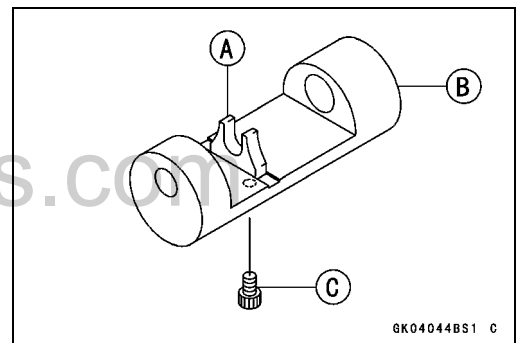
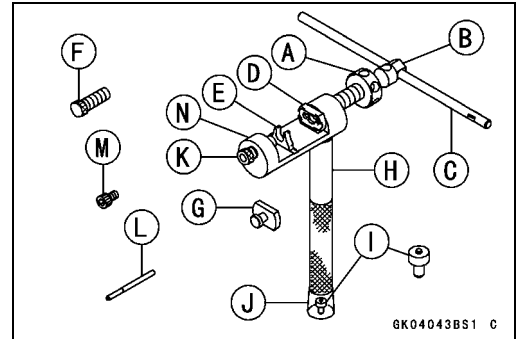

Drive Chain

- Screw in the pressure bolt assy [A] in the pressure bolt (A) [B].
- Install the handle lever [C] to the pressure bolt assy.
- Turn in the handle lever until the link pin [D] removed at the link plate [E].

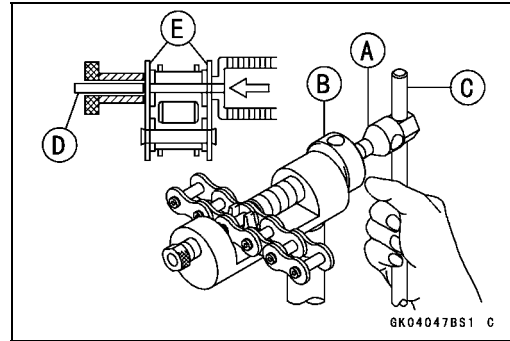

- Repeat the above steps for other link pin [A].

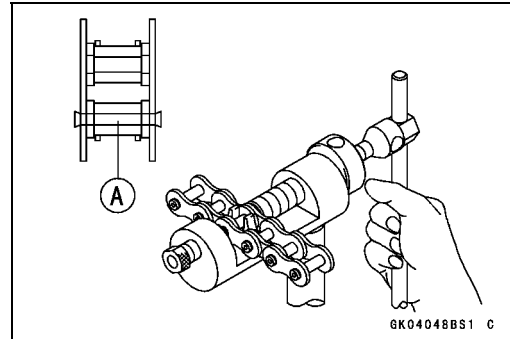

Drive Chain Installation

- Engage new drive chain to the old drive chain and pull the end of the old drive chain until they are changing the position.
- Remove the old drive chain from the new drive chain.
- Apply grease to the link pins [A] and grease seals.
- Engage the drive chain on the rear sprocket through the swingarm.
- Install the grease seals [B] on the link pins.
- Insert the link pins in the drive chain ends.
- Install:

Grease Seals [C]

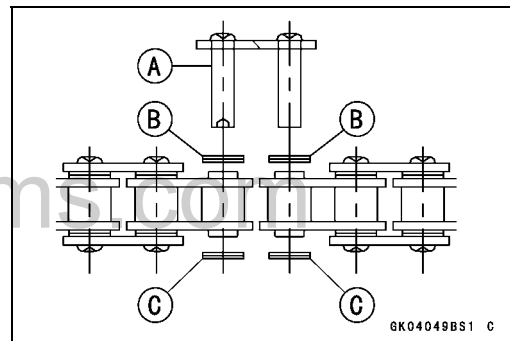

- Set the adjuster bolt (yellow) [A], wedge holder and wedge pin [B], and pressure holder [C] on the body [D].
- Hold the wedge holder and wedge pin, using the adjuster bolt (yellow).
- Apply grease to the inside [E] of the pressure holder.

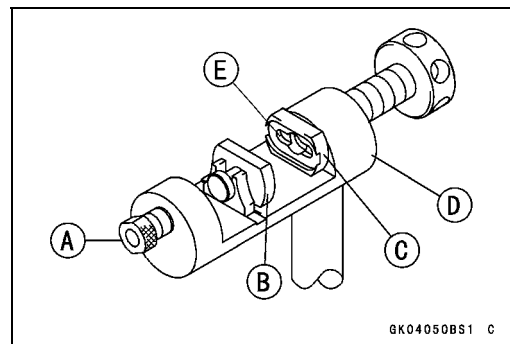

Drive Chain

○Install the link plate so that the gold painted [A] faces out.

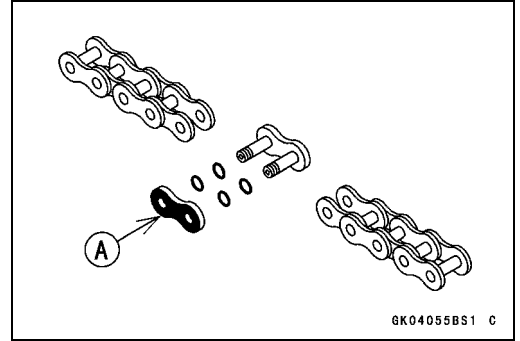

- Fit the link plate [A] in the pressure holder [B].
- Fit the link plates of the chain into the wedge holder and wedge pin [D].
- Turn the pressure bolt (A) [C] by hand until link plate touches the link pins.

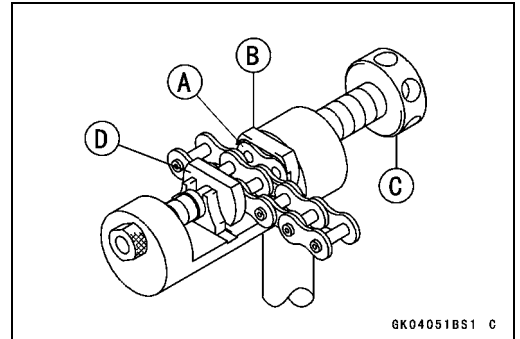

- Install the handle lever [A] onto the pressure bolt (A) [B].
- Turn the handle lever, press in the link plate to the link pins.

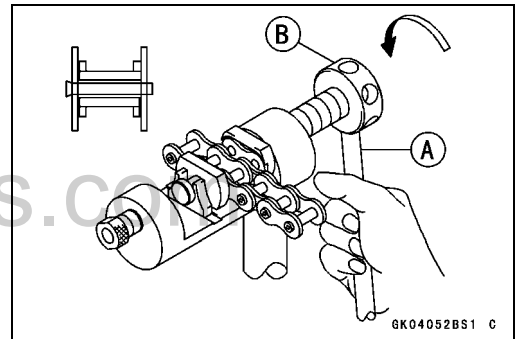

- Set the adjuster bolt (yellow) [A], guide plate [B], and flare pin [C] on the body.
- Apply grease to the tip [D] of the flare pin.
- Fit the adjuster bolt (yellow) to the link pin [E].

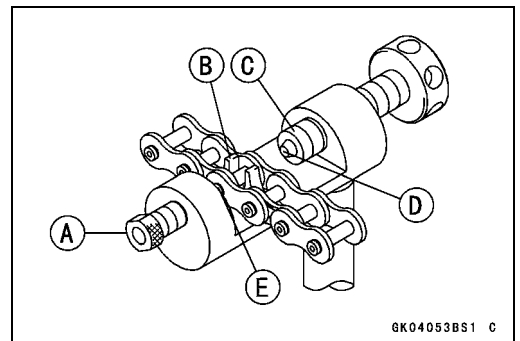

- Install the grip lever [A] onto the pressure bolt (A) [B].
- Stake the link pin end by the handle lever about 9/10 turns [C].
- Repeat the above steps for other link pin [D].

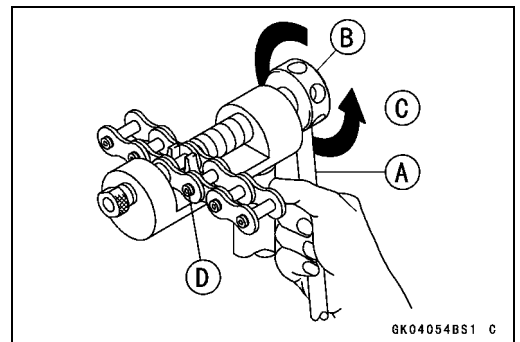

Drive Chain

- After staking, measure the outside diameter [A] of the link pin and link plates width [B].

Link Pin Outside Diameter

Standard: 5.60 ~ 5.90 mm (0.22 ~ 0.23 in.)

Link Plates Outside Width

Standard: 19.70 ~ 20.00 mm (0.775 ~ 0.787 in.)

- ★ If the reading exceeds the specified length, cut and rejoin the chain again.
- Check:
 - Movement of the Rollers
- Adjust the drive chain slack after installing the chain (see Drive Chain Slack Inspection in the Periodic Maintenance chapter).

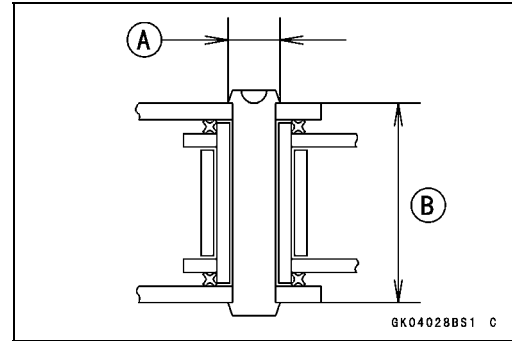

Sprocket, Coupling

Engine Sprocket Removal

- Remove:
 - Lower Fairings (see Lower Fairing Removal in the Frame chapter)
 - Shift Lever Bolt [A]
- Pull the shift lever [B].

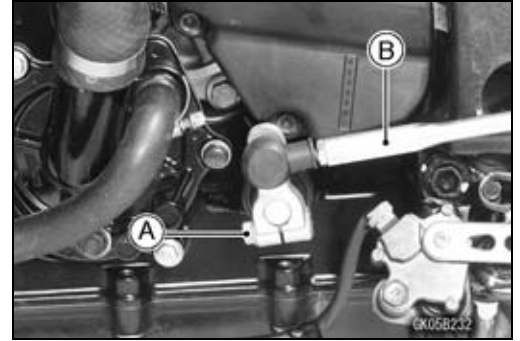

- Remove:
 - Engine Sprocket Cover Bolts [A]
 - Engine Sprocket Cover [B]

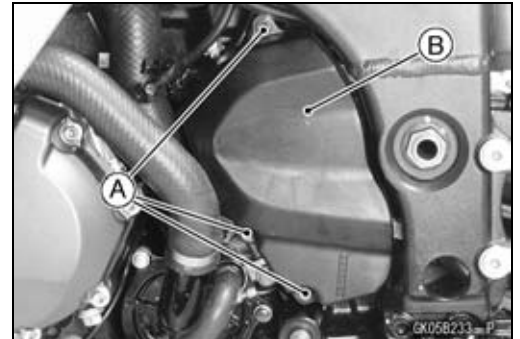

- Flatten out the bended washer [A].
- Remove the engine sprocket nut [B] and washer.

NOTE

○When loosening the engine sprocket nut, hold the rear brake on.

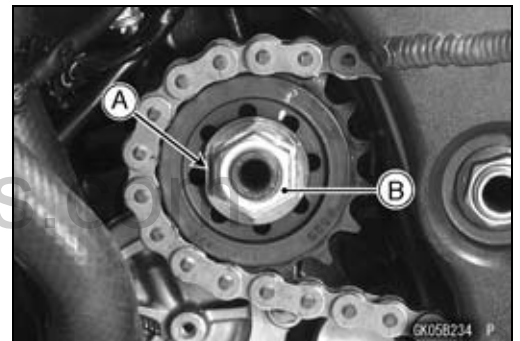

- Raise the rear wheel off the ground.
- Remove the axle cotter pin, and loosen the rear axle nut.
- Loosen the both chain adjuster locknut to loosen the drive chain.
- Remove the drive chain from the rear sprocket toward the right.
- Pull the engine sprocket [A] with drive chain [B] off the output shaft [C].
- Disengage the drive chain from the engine sprocket.

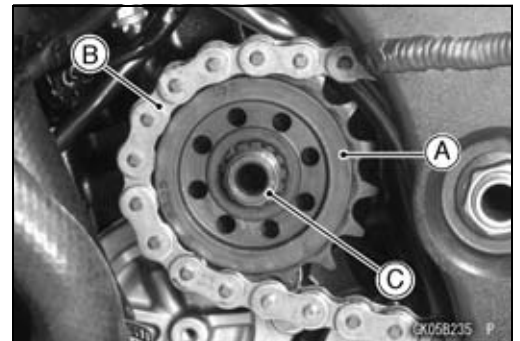

Engine Sprocket Installation

- Replace the sprocket washer and axle cotter pin.
- Install the engine sprocket onto the shaft.
- Apply molybdenum disulfide oil solution to the threads of the output shaft and the seating surface of the engine sprocket nut.
- After torquing the engine sprocket nut, bend [A] the one side of the washer over the nut.

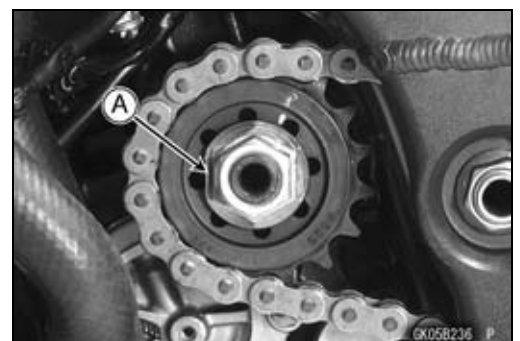

NOTE

○Tighten the nut while applying the rear brake.

Torque - Engine Sprocket Nut: 125 N·m (12.7 kgf·m, 92 ft·lb)

- Adjust the drive chain slack after installing the sprocket (see Drive Chain Slack Adjustment in the Periodic Maintenance chapter).

Sprocket, Coupling

- Install the guide [A] into the sprocket cover [B] so that the hook [C] of the guide fits into the receiver [D].

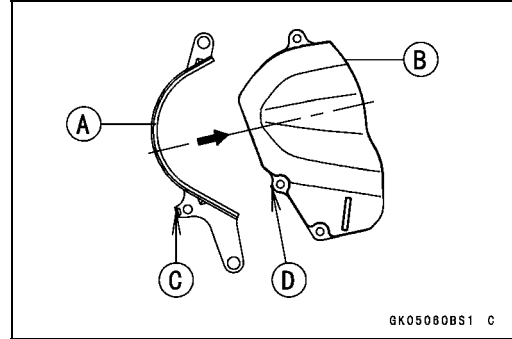

- Install the engine sprocket cover [A] with the guide [B].
- Install the pins [C] into the holes [D].
- Tighten the engine sprocket cover bolts.
 - Torque - Engine Sprocket Cover Bolts: 10 N·m (1.0 kgf·m, 89 in·lb)**
- Install the removed parts (see appropriate chapters).

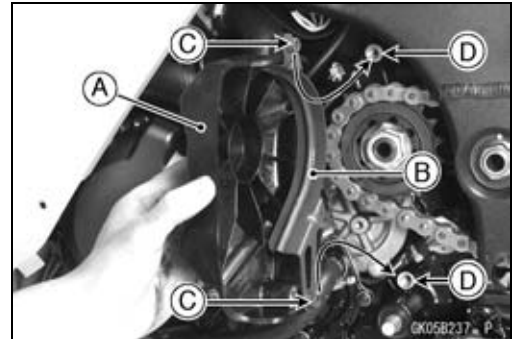

Rear Sprocket Removal

- Remove the rear wheel (see Rear Wheel Removal in the Wheels/Tires chapter).

CAUTION

Do not lay the wheel on the ground with the disc facing down. This can damage or warp the disc. Place blocks under the wheel so that the disc does not touch the ground.



- Remove the rear sprocket nuts [A].
- Remove the rear sprocket [B].

Rear Sprocket Installation

- Install the sprocket facing the tooth number marking [A] outward.
- Tighten the rear sprocket nuts.
 - Torque - Rear Sprocket Nuts: 59 N·m (6.0 kgf·m, 44 ft·lb)**
- Install the rear wheel (see Rear Wheel Installation in the Wheels/Tires chapter).

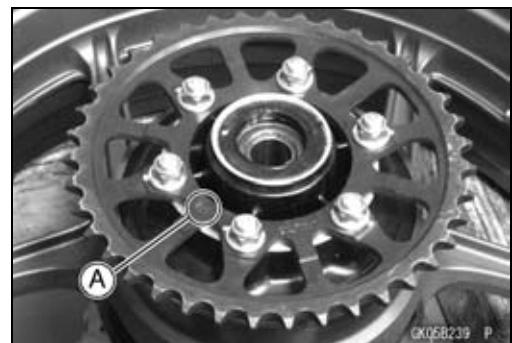

Sprocket, Coupling

Coupling Installation

- Grease the following and install the coupling.
 - Coupling Grease Seal Lips [A]
 - Coupling Internal Surface [B]

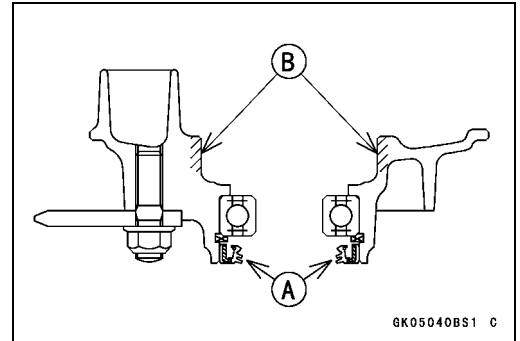

- Apply grease to the O-ring [A].
- Install the collar [B].

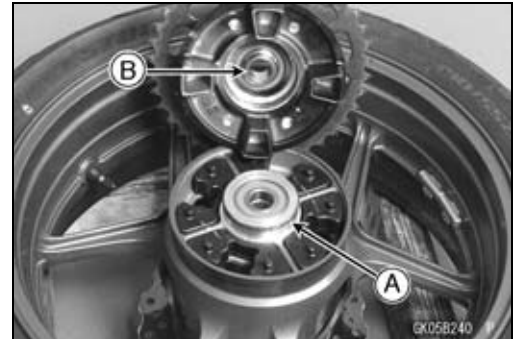

Coupling Bearing Removal

- Remove:
 - Coupling
 - Grease Seal
 - Circlip [A]
- Special Tool - Inside Circlip Pliers [B]: 57001-143

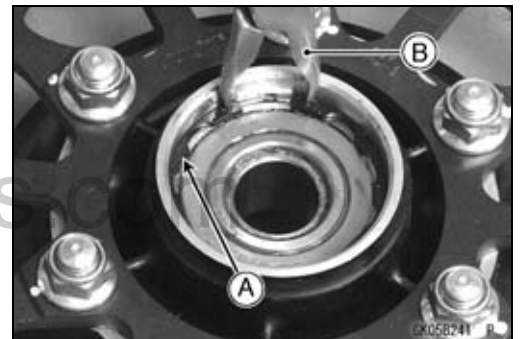

- Remove the bearing [A] by tapping from the wheel side.
- Special Tool - Bearing Driver Set [B]: 57001-1129

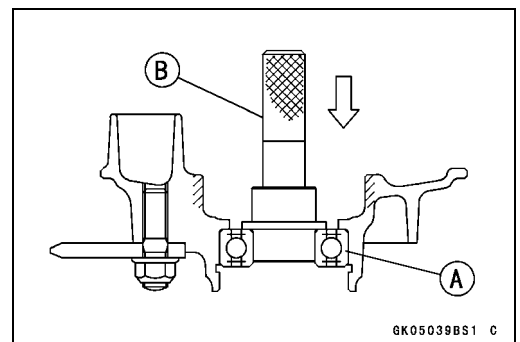

Coupling Bearing Installation

- Replace the bearing with a new one.
- Press in the bearing [A] until it is bottomed.
 - Special Tool - Bearing Driver Set [B]: 57001-1129
- Pack the bearing with high temperature grease.
- Replace the circlip with a new one.
 - Special Tool - Inside Circlip Pliers: 57001-143

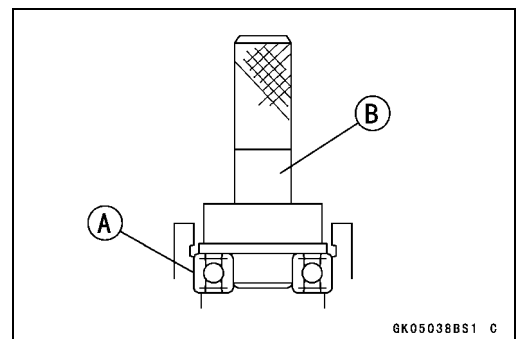

Sprocket, Coupling

- Replace the grease seal with a new one.
- Press in the grease seal so that the seal surface is flush with the end of the hole.
- Apply high-temperature grease to the grease seal lips.

Special Tool - Bearing Driver Set: 57001-1129

Coupling Bearing Inspection

Since the coupling bearing is made to extremely close tolerances, the clearance can not normally be measured.

NOTE

○ It is not necessary to remove the coupling bearing for inspection. If the bearing is removed, it will need to be replaced with a new one.

- Turn the bearing in the coupling back and forth [A] while checking for plays, roughness, or binding.
- ★ If bearing play, roughness, or binding is found, replace the bearing.
- Examine the bearing seal [B] for tears or leakage.
- ★ If the seal is torn or is leaking, replace the bearing.

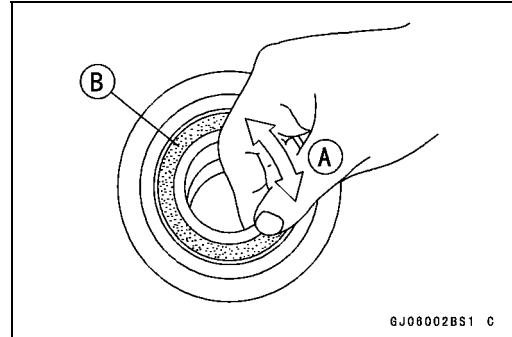

Coupling Bearing Lubrication

NOTE

○ Since the coupling bearing is packed with grease and sealed, lubrication is not required.

Coupling Damper Inspection

- Remove the rear wheel coupling, and inspect the rubber dampers [A].
- Replace the damper if it appears damaged or deteriorated.

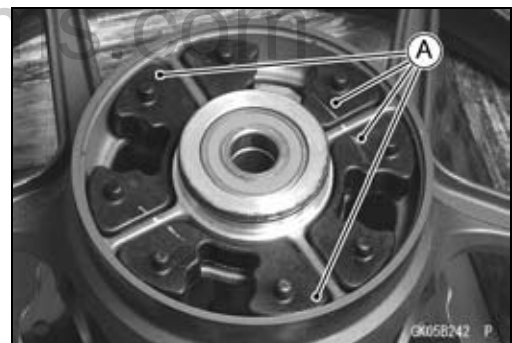

Sprocket Wear Inspection

- Visually inspect the engine and rear sprocket teeth for wear and damage.
- ★ If the teeth are worn as illustrated, replace the sprocket, and inspect the drive chain wear (see Drive Chain Wear Inspection in the Periodic Maintenance chapter).
 - Worn Tooth (Engine Sprocket) [A]
 - Worn Tooth (Rear Sprocket) [B]
 - Direction of Rotation [C]

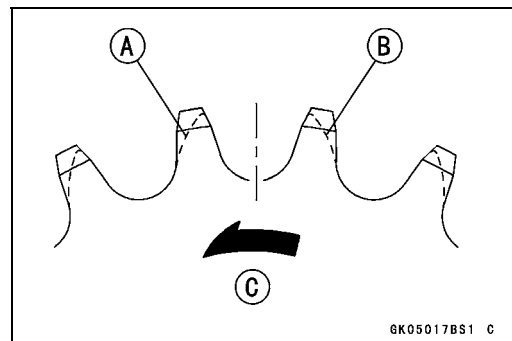

NOTE

○ If a sprocket requires replacement, the chain is probably worn also.
 When replacing a sprocket, inspect the chain.

Sprocket, Coupling

Rear Sprocket Warp Inspection

- Raise the rear wheel off the ground (see Rear Wheel Removal in the Wheels/Tires chapter) so that it will turn freely.
- Set a dial gauge [A] against the rear sprocket [B] near the teeth as shown, and rotate [C] the rear wheel to measure the sprocket runout (warp). The difference between the highest and lowest dial gauge readings is the amount of runout (warp).
- ★ If the runout exceeds the service limit, replace the rear sprocket.

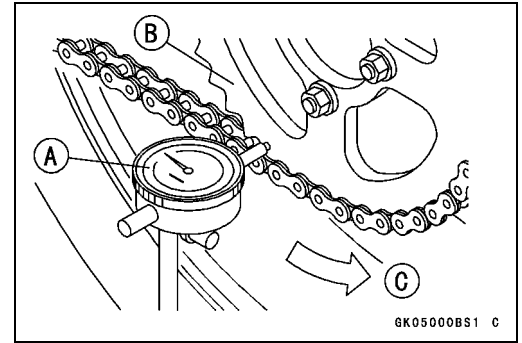

Rear Sprocket Warp

Standard: 0.4 mm (0.016 in.) or less

Service Limit: 0.5 mm (0.02 in.)

www.zxforums.com

www.zxforums.com

Brakes

Table of Contents

Exploded View	12-2
Specifications	12-6
Special Tools	12-7
Brake Lever, Brake Pedal.....	12-8
Brake Lever Position Adjustment.....	12-8
Brake Pedal Position Inspection	12-8
Brake Pedal Position Adjustment	12-8
Brake Pedal Removal	12-8
Brake Pedal Installation	12-9
Calipers	12-10
Front Caliper Removal.....	12-10
Rear Caliper Removal.....	12-10
Caliper Installation	12-10
Front Caliper Disassembly.....	12-11
Front Caliper Assembly.....	12-11
Rear Caliper Disassembly	12-11
Rear Caliper Assembly	12-11
Caliper Fluid Seal Damage.....	12-11
Rear Caliper Dust Boot and Friction Boot Damage	12-12
Caliper Piston and Cylinder Damage.....	12-12
Rear Caliper Holder Shaft Wear.....	12-12
Brake Pads.....	12-13
Front Brake Pad Removal.....	12-13
Front Brake Pad Installation.....	12-13
Rear Brake Pad Removal	12-14
Rear Brake Pad Installation	12-14
Brake Pad Wear Inspection	12-14
Master Cylinder	12-15
Front Master Cylinder Removal	12-15
Front Master Cylinder Installation	12-15
Rear Master Cylinder Removal.....	12-16
Rear Master Cylinder Installation.....	12-16
Front Master Cylinder Disassembly	12-16
Rear Master Cylinder Disassembly.....	12-16
Master Cylinder Assembly	12-16
Master Cylinder Inspection (Visual Inspection).....	12-17
Brake Disc	12-18
Brake Disc Removal	12-18
Brake Disc Installation	12-18
Brake Disc Wear	12-18
Brake Disc Warp	12-18
Brake Fluid	12-19
Brake Fluid Level Inspection.....	12-19
Brake Fluid Change	12-19
Brake Line Bleeding.....	12-19
Brake Hose.....	12-23
Brake Hose Removal/Installation.....	12-23
Brake Hose Inspection.....	12-23

Exploded View

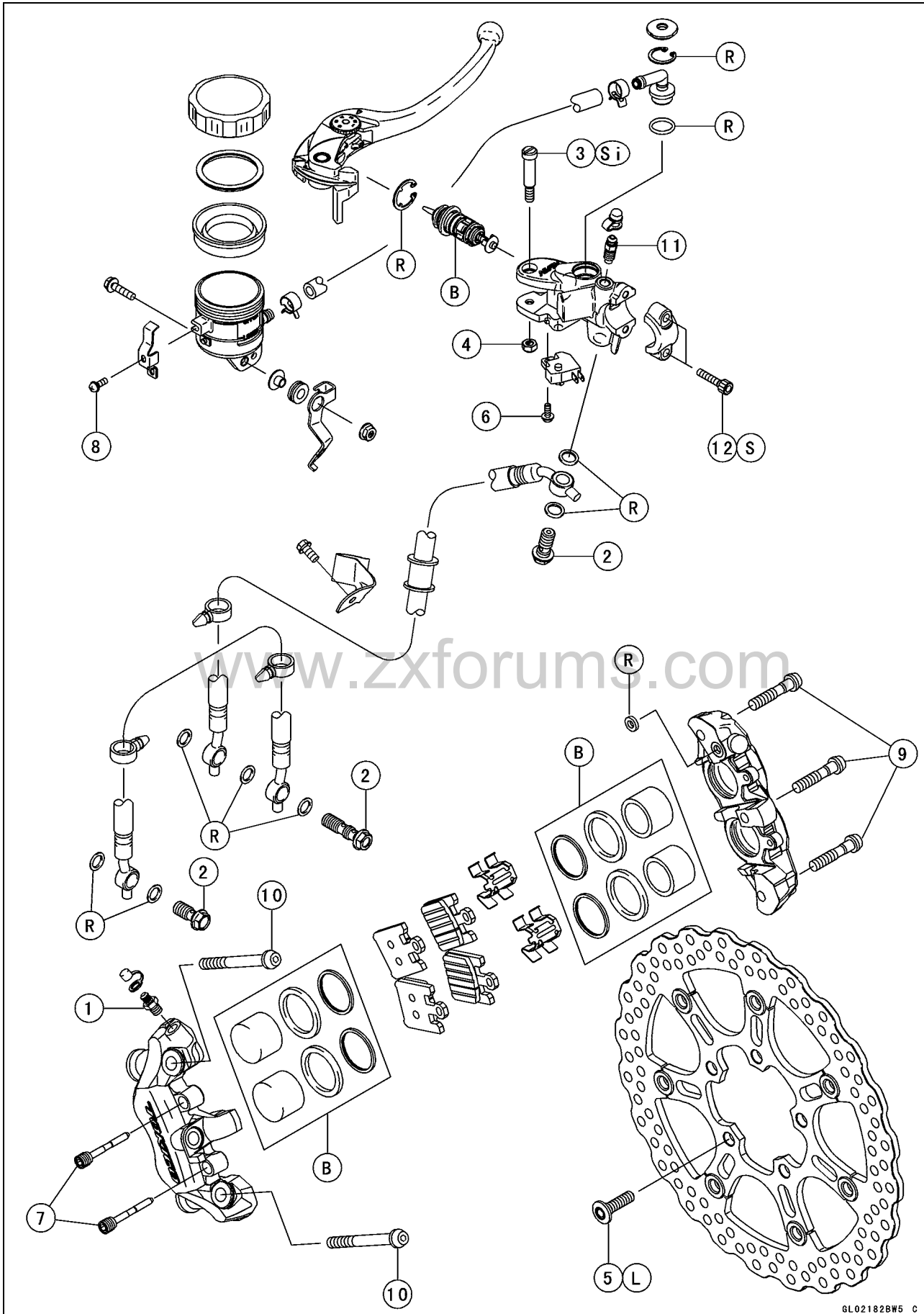

GL02182BW5 C

Exploded View

No.	Fastener	Torque			Remarks
		N·m	kgf·m	ft·lb	
1	Bleed Valves	7.8	0.80	69 in·lb	
2	Brake Hose Banjo Bolts	25	2.5	18	
3	Brake Lever Pivot Bolt	1.0	0.10	9 in·lb	Si
4	Brake Lever Pivot Bolt Nut	5.9	0.60	52 in·lb	
5	Front Brake Disc Mounting Bolts	27	2.8	20	L
6	Front Brake Light Switch Screw	1.2	0.12	11 in·lb	
7	Front Brake Pad Pins	15	1.5	11	
8	Front Brake Reservoir Cap Stopper Screw	1.2	0.12	11 in·lb	
9	Front Caliper Assembly Bolts	22	2.2	16	
10	Front Caliper Mounting Bolts	34	3.5	25	
11	Front Brake Master Cylinder Bleed Valve	5.4	0.55	48 in·lb	
12	Front Master Cylinder Clamp Bolts	8.8	0.90	78 in·lb	S

B: Apply brake fluid.

G: Apply grease.

L: Apply a non-permanent locking agent.

R: Replacement Parts

S: Follow the specified tightening sequence.

Si: Apply silicone grease (ex. PBC grease).

www.zxforums.com

Exploded View

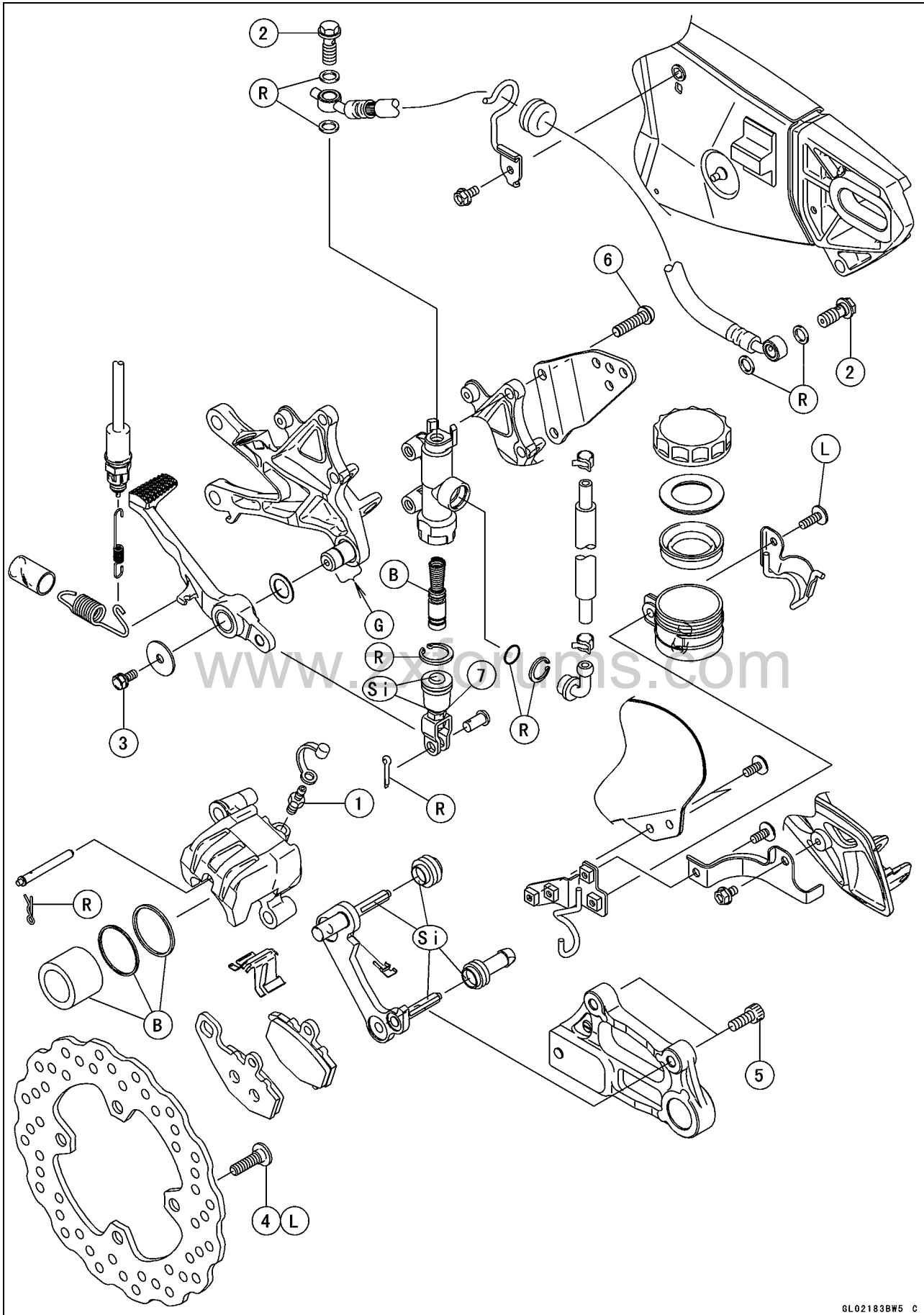

GL02183BW5 C

Exploded View

No.	Fastener	Torque			Remarks
		N·m	kgf·m	ft·lb	
1	Bleed Valve	7.8	0.80	69 in·lb	
2	Brake Hose Banjo Bolts	25	2.5	18	
3	Brake Pedal Bolt	8.8	0.90	78 in·lb	
4	Rear Brake Disc Mounting Bolts	27	2.8	20	L
5	Rear Caliper Mounting Bolts	25	2.5	18	
6	Rear Master Cylinder Mounting Bolts	25	2.5	18	
7	Rear Master Cylinder Push Rod Locknut	17	1.7	13	

B: Apply brake fluid.

G: Apply grease.

L: Apply a non-permanent locking agent.

R: Replacement Parts

Si: Apply silicone grease (ex. PBC grease).

www.zxforums.com

Specifications

Item	Standard	Service Limit
Brake Lever, Brake Pedal		
Brake Lever Position	6-way adjustable (to suit rider)	— — —
Brake Lever Free Play	Non-adjustable	— — —
Pedal Free Play	Non-adjustable	— — —
Pedal Position	About 90 mm (3.5 in.) below footpeg top	— — —
Brake Discs		
Thickness:		
Front	5.8 ~ 6.2 mm (0.23 ~ 0.24 in.)	5.5 mm (0.22 in.)
Rear	4.8 ~ 5.2 mm (0.19 ~ 0.20 in.)	4.5 mm (0.18 in.)
Runout	TIR 0.15 mm (0.006 in.) or less	TIR 0.3 mm (0.01 in.)

www.zxforums.com

Special Tools

Inside Circlip Pliers:
57001-143

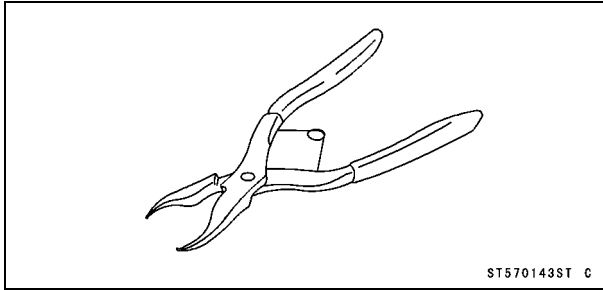

Jack Attachment:
57001-1608

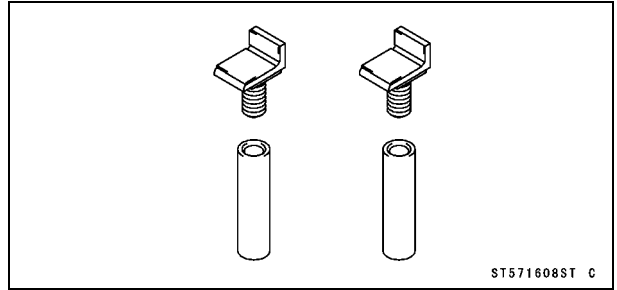

Jack:
57001-1238

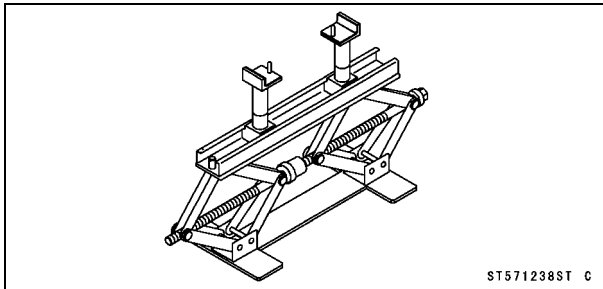

www.zxforums.com

Brake Lever, Brake Pedal

Brake Lever Position Adjustment

The brake lever adjuster has 6 positions so that the brake lever position can be adjusted to suit the operator's hand.

- Push the lever forward and turn the adjuster [A] to align the number with the arrow mark [B] on the lever holder.
- The distance from the grip to the lever is minimum at number 6 and maximum at number 1.

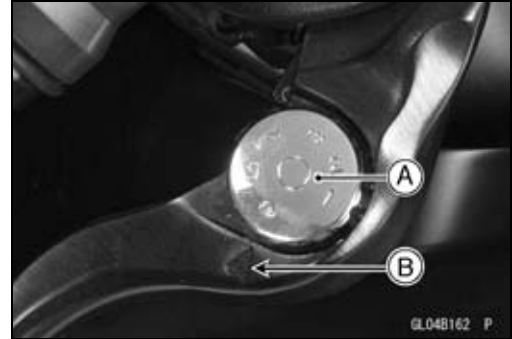

Brake Pedal Position Inspection

- Check that the brake pedal [A] is in the correct position. Footpeg [B]

Pedal Position

Standard: About 90 mm (3.5 in.) [C] below top of footpeg

- ★ If it is incorrect, adjust the brake pedal position.

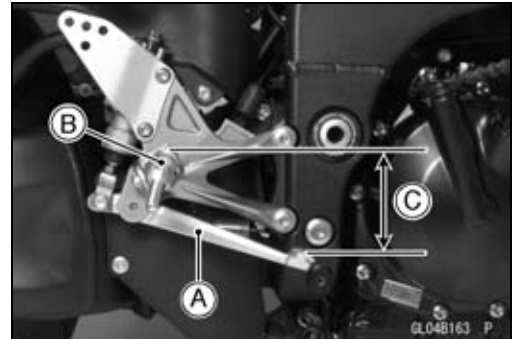

Brake Pedal Position Adjustment

NOTE

○ Usually it is not necessary to adjust the pedal position, but always adjust it when push rod locknut has been loosened.

- Loosen the locknut [A] and turn the push rod with the hex head [B] to achieve the correct pedal position.
- ★ If the length [C] shown is 70 ± 1 mm (2.8 ± 0.04 in.), the pedal position will be within the standard range.
- Tighten:

Torque - Rear Master Cylinder Push Rod Locknut: 17 N·m (1.7 kgf·m, 13 ft·lb)

- Check the brake light switch operation (see Brake Light Switch Operation Inspection in the Periodic Maintenance chapter).

Brake Pedal Removal

- Remove:
 - Rear Master Cylinder Mounting Bolts [A]
 - Right Footpeg Bracket Bolts [B]

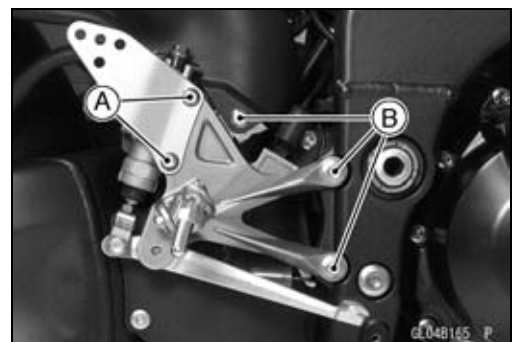
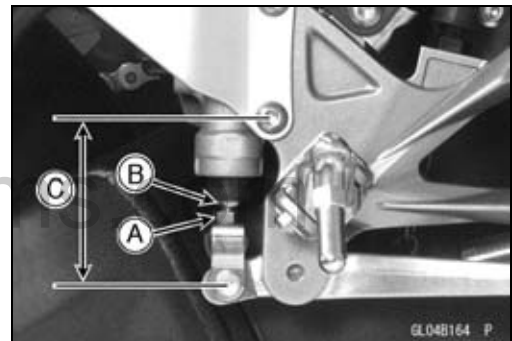

Brake Lever, Brake Pedal

- Remove:
 - Cotter Pin [A]
 - Joint Pin [B]
 - Rear Brake Light Switch Spring [C]
 - Return Spring [D]
- Remove the mounting bolt [E] and take out the brake pedal.

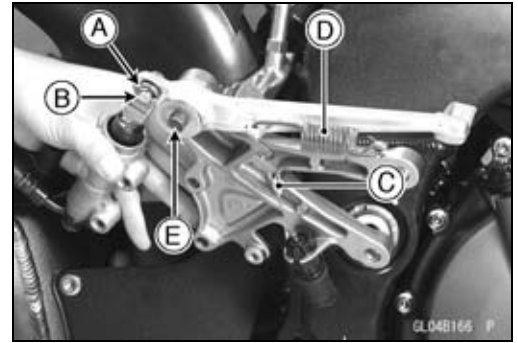

Brake Pedal Installation

- Apply grease to the pivot shaft [A] and install the washer [B].
- Install:
 - Brake Pedal [C]
 - Washer [D]
 - Brake Pedal Bolt [E]

Torque - Brake Pedal Bolt: 8.8 N·m (0.90 kgf·m, 78 in·lb)

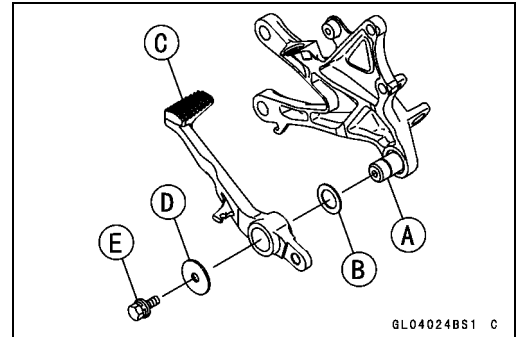

- Hook the lower end of the rear brake light switch spring [A] on the pedal hook.
- Install the spring so that the hook turns outside.
- Hook the upper end of the return spring [B] on the pedal hook.

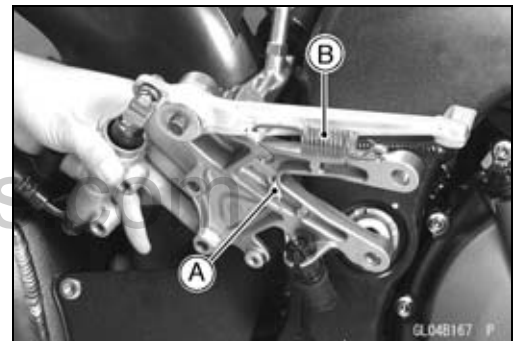

- Replace the cotter pin with a new one.
- Insert the cotter pin [A] and bend the pin ends [B].

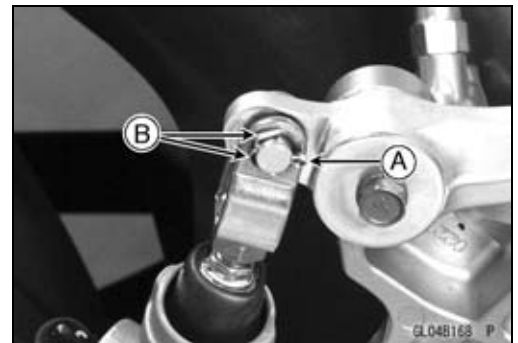

- Install the right footpeg bracket.
 - Torque - Front Footpeg Bracket Bolts: 25 N·m (2.5 kgf·m, 18 ft·lb)**
- Depress the brake pedal [A] and then align the bolts holes of the master cylinder [B].
- Torque - Rear Master Cylinder Mounting Bolts: 25 N·m (2.5 kgf·m, 18 ft·lb)**
- Check the brake pedal position (see Brake Pedal Position Inspection).

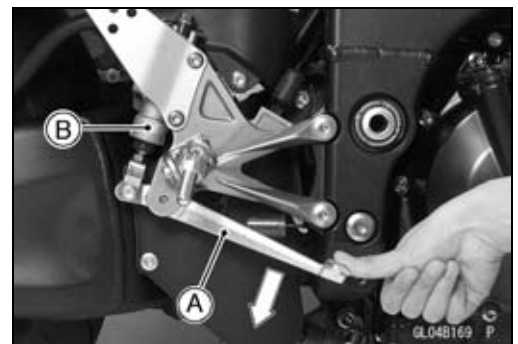

Calipers

Front Caliper Removal

- Loosen the banjo bolt [A] at the brake hose lower end, and tighten it loosely.
- Unscrew the caliper mounting bolts [B], and detach the caliper [C] from the disc.

CAUTION

Do not loosen the caliper assembly bolts [D]. Take out only the caliper mounting bolts for caliper removal. Loosening the caliper assembly bolts will cause brake fluid leakage.

- Unscrew the banjo bolt and remove the brake hoses [E] from the caliper (see Brake Hose Removal/Installation).

CAUTION

Immediately wash away any brake fluid that spills.

NOTE

○If the caliper is to be disassembled after removal and if compressed air is not available, disassemble the caliper before the brake hose is removed (see Front Caliper Disassembly).

Rear Caliper Removal

- Loosen the banjo bolt [A] at the brake hose lower end, and tighten it loosely.
- Unscrew the caliper mounting bolts [B], and detach the caliper [C] from the disc.
- Unscrew the banjo bolt and remove the brake hose [D] from the caliper.

CAUTION

Immediately wash away any brake fluid that spills.

NOTE

○If the caliper is to be disassembled after removal and if compressed air is not available, disassemble the caliper before the brake hose is removed (see Rear Caliper Disassembly).

Caliper Installation

- Install the caliper and brake hose lower end.
- Replace the washers on each side of hose fitting with new ones.
- Tighten:

Torque - Caliper Mounting Bolts

Front: 34 N·m (3.5 kgf·m, 25 ft·lb)

Rear: 25 N·m (2.5 kgf·m, 18 ft·lb)

Brake Hose Banjo Bolts: 25 N·m (2.5 kgf·m, 18 ft·lb)

- Check the fluid level in the brake reservoirs.
- Bleed the brake line (see Brake Line Bleeding).
- Check the brake for good braking power, no brake drag, and no fluid leakage.

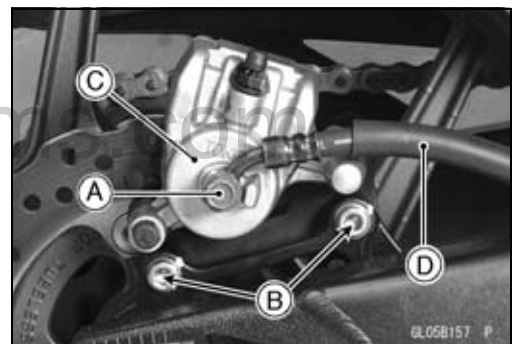
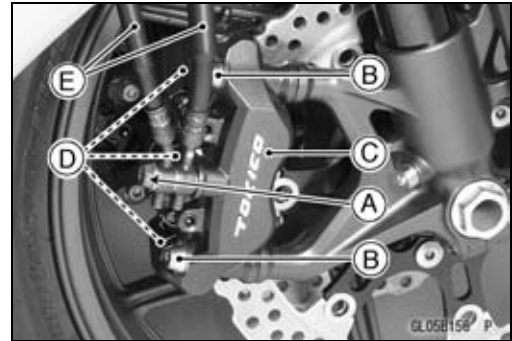

Calipers

⚠ WARNING

Do not attempt to drive the motorcycle until a full brake lever or pedal is obtained by pumping the brake lever or pedal until the pads are against the disc. The brakes will not function on the first application of the lever or pedal if this is not done.

Front Caliper Disassembly

- Refer to the Caliper Rubber Parts Replacement in the Periodic Maintenance chapter (see Caliper Rubber Parts Replacement in the Periodic Maintenance chapter).

Front Caliper Assembly

- Refer to the Caliper Rubber Parts Replacement in the Periodic Maintenance chapter (see Caliper Rubber Parts Replacement in the Periodic Maintenance chapter).

Rear Caliper Disassembly

- Refer to the Caliper Rubber Parts Replacement in the Periodic Maintenance chapter (see Caliper Rubber Parts Replacement in the Periodic Maintenance chapter).

Rear Caliper Assembly

- Refer to the Caliper Rubber Parts Replacement in the Periodic Maintenance chapter (see Caliper Rubber Parts Replacement in the Periodic Maintenance chapter).

Caliper Fluid Seal Damage

The fluid seal (piston seal) [A] is placed around the piston to maintain clearance between the pad and the disc. If the seal is in a poor condition, it could lead the pad to wear excessively or the brake to drag, which may cause the temperature of the discs or the brake fluid to increase.

- Replace the fluid seal if it exhibits any of the conditions listed below.
 - Brake fluid leakage around the pad.
 - Brakes overheat.
 - Considerable difference in inner and outer pad wear.
 - Seal and piston are stuck together.
- ★ If the fluid seal is replaced, replace the dust seal [B] as well. Also, replace all seals every other time the pads are changed.

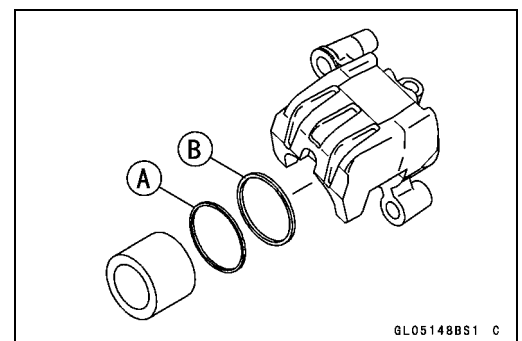
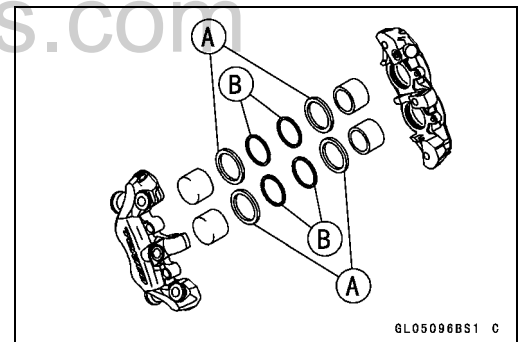

Calipers

Rear Caliper Dust Boot and Friction Boot Damage

- Check that the dust boot [A] and friction boot [B] are not cracked, worn, swollen, or otherwise damaged.
- ★ If they show any damage, replace it.

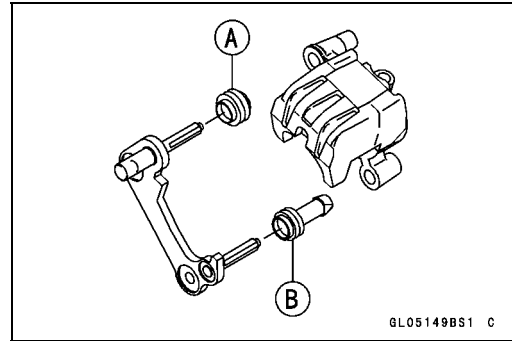

Caliper Piston and Cylinder Damage

- Visually inspect the pistons [A] and cylinder surfaces [B].
- ★ Replace the caliper if the cylinder and piston are badly scored or rusty.

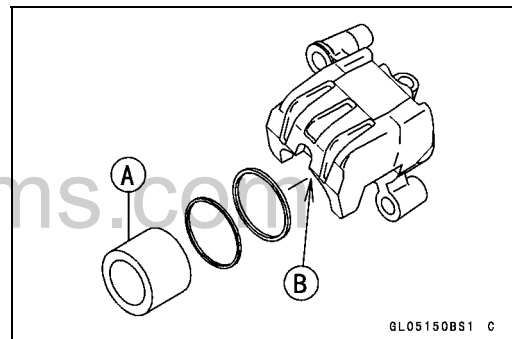
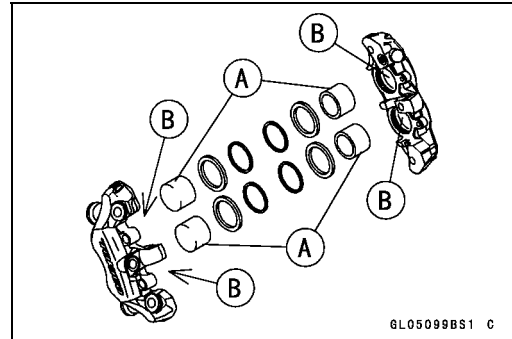

Rear Caliper Holder Shaft Wear

The caliper body must slide smoothly on the caliper holder shafts [A]. If the body does not slide smoothly, one pad will wear more than the other, pad wear will increase, and constant drag on the disc will raise brake and brake fluid temperature.

- Check to see that the caliper holder shafts are not badly worn or stepped, and that the rubber friction boots are not damaged.
- ★ If the rubber friction boot is damaged, replace the rubber friction boot. To replace the friction boot, remove the pads and the caliper bracket.
- ★ If the caliper holder shaft is damaged, replace the caliper bracket.

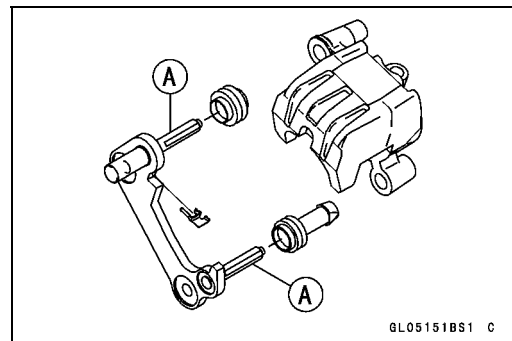

Brake Pads

Front Brake Pad Removal

- Loosen:
Pad Pins [A]

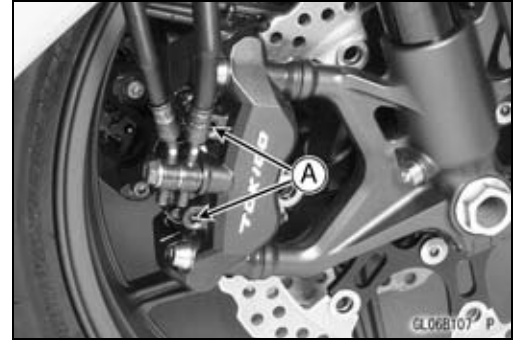

- Remove:
Pad Pins [A]
Pad Springs [B]
Brake Pads [C]

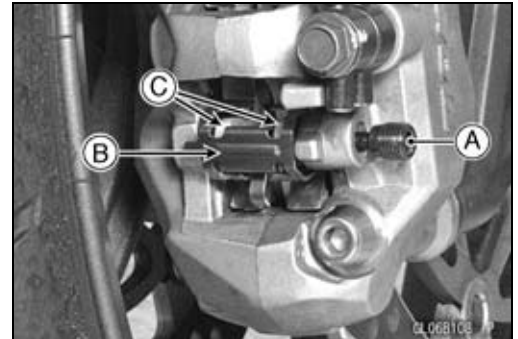

Front Brake Pad Installation

- Push the caliper pistons in by hand as far as they will go.
- Install the outside pad [A] and insert the pad pin [B] as shown.

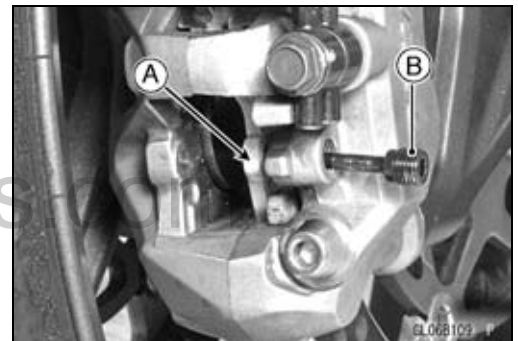

- Set:
Inside Pad [A]
Pad Spring [B]
- Pushing the pin holder [C] to hole of the pad and insert the pad pin.

Torque - Front Brake Pad Pins: 15 N·m (1.5 kgf·m, 11 ft·lb)

⚠ WARNING

Do not attempt to drive the motorcycle until a full brake lever is obtained by pumping the brake lever and the pads are against the disc. The brake will not function on the first application of the lever if this is not done.

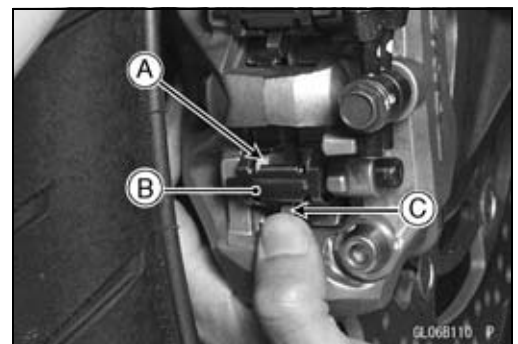

Brake Pads

Rear Brake Pad Removal

- Remove the caliper with the hose installed.
- Remove:
 - Clip [A]
 - Pad Pin [B]
 - Brake Pads [C]

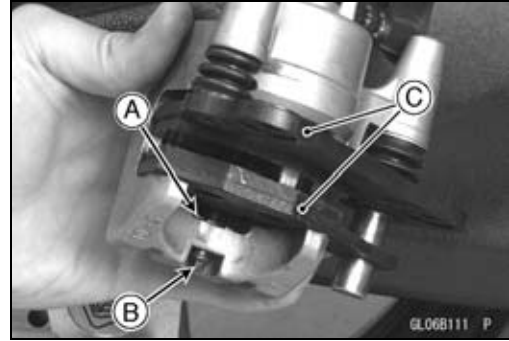

Rear Brake Pad Installation

- Push the caliper piston in by hand as far as it will go.
- Install the pad spring in place.
- Install the piston side pad [A] first, and then another pad.
- Fit the projections [B] of the pad into the recesses [C] of the caliper holder.
- Install the pad pin and clip. The clip must be “outside” of the pads.
- Install the caliper (see Caliper Installation).

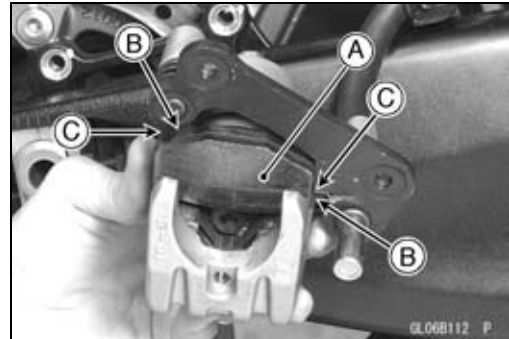

⚠ WARNING

Do not attempt to drive the motorcycle until a full brake pedal is obtained by pumping the brake pedal until the pads are against the disc. The brake will not function on the first application of the pedal if this is not done.

Brake Pad Wear Inspection

- Refer to the Brake Pad Wear Inspection in the Periodic Maintenance chapter (see Brake Pad Wear Inspection in the Periodic Maintenance chapter).

Master Cylinder

Front Master Cylinder Removal

- Remove the reservoir bracket nut [A].



- Remove the banjo bolt [A] to disconnect the brake hose from the master cylinder (see Brake Hose Removal/Installation).
- Unscrew the clamp bolts [B], and take off the master cylinder [C] as an assembly with the reservoir, brake lever, and brake switch installed.
- Disconnect the front brake light switch connector [D].

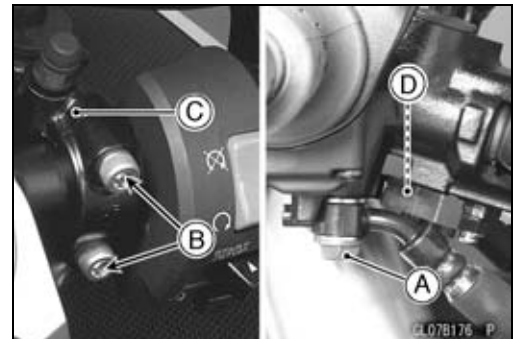

CAUTION

Immediately wash away any brake fluid that spills.

- Remove:
 - Brake Lever Pivot Bolt [A] and Nut
 - Brake Lever [B]
 - Clamp [C] (Slide Out)
 - Brake Hose [D]
 - Front Brake Light Switch [E]

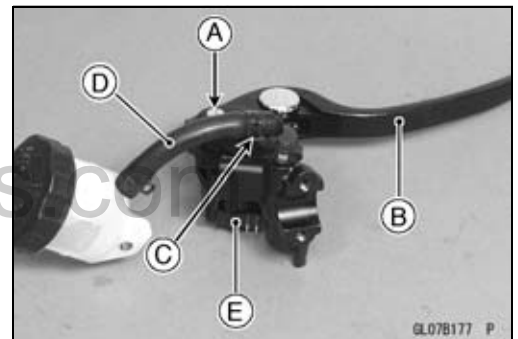

Front Master Cylinder Installation

- Set the front master cylinder to match its mating surface [A] to the punch mark [B] of the handlebar.
- The master cylinder clamp must be installed with the arrow mark [C] upward.
- Tighten the upper clamp bolt first, and then the lower clamp bolt.

Torque - Front Master Cylinder Clamp Bolts: 8.8 N·m (0.90 kgf·m, 78 in·lb)

- Replace the washers that are on each side of the hose fitting with new ones.
- Tighten:
 - Torque - Brake Hose Banjo Bolt: 25 N·m (2.5 kgf·m, 18 ft·lb)**
- Bleed the brake line (see Brake Line Bleeding).
- Check the brake for good braking power, no brake drag, and no fluid leakage.

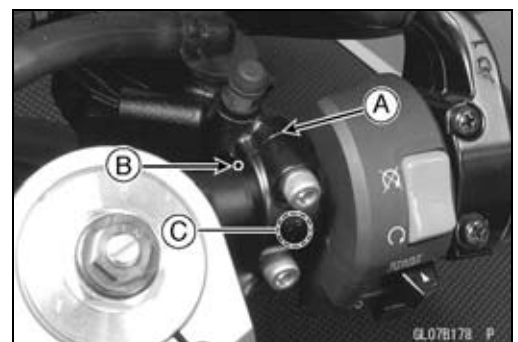

Master Cylinder

Rear Master Cylinder Removal

- Unscrew the brake hose banjo bolt [A] and brake hose [B].
- Remove:
 - Cotter Pin [C]
 - Joint Pin [D]
 - Bolts [E]
 - Foot Guard [F]
 - Rear Master Cylinder
- Slide out the clamp [G].
- Pull off the reservoir hose lower end [H], and drain the brake fluid into a container.

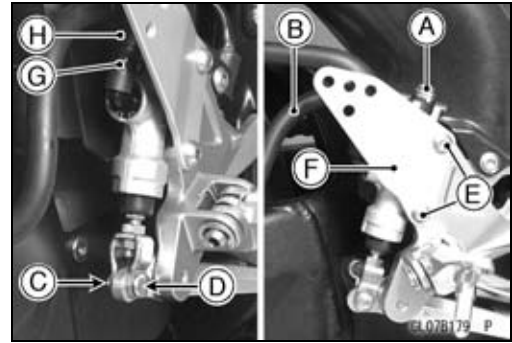

Rear Master Cylinder Installation

- Replace the cotter pin with a new one.
- Replace the washers that are on each side of hose fitting with new ones.
- Tighten:
 - Torque - Rear Master Cylinder Mounting Bolts: 25 N·m (2.5 kgf·m, 18 ft·lb)
 - Brake Hose Banjo Bolt: 25 N·m (2.5 kgf·m, 18 ft·lb)
- Bleed the brake line (see Brake Line Bleeding).
- Check the brake for good braking power, no brake drag, and no fluid leakage.

Front Master Cylinder Disassembly

- Refer to the Master Cylinder Rubber Parts Replacement in the Periodic Maintenance chapter (see Master Cylinder Rubber Parts Replacement in the Periodic Maintenance chapter).

Rear Master Cylinder Disassembly

- Refer to the Master Cylinder Rubber Parts Replacement in the Periodic Maintenance chapter (see Master Cylinder Rubber Parts Replacement in the Periodic Maintenance chapter).

Master Cylinder Assembly

- Refer to the Master Cylinder Rubber Parts Replacement in the Periodic Maintenance chapter (see Master Cylinder Rubber Parts Replacement in the Periodic Maintenance chapter).

Master Cylinder

Master Cylinder Inspection (Visual Inspection)

- Remove the master cylinders (see Front/Rear Master Cylinder Removal).
- Disassemble the front and rear master cylinders (see Master Cylinder Rubber Parts Replacement in the Periodic Maintenance chapter).
- Check that there are no scratches, rust or pitting on the inner wall [A] of each master cylinder and on the outside of each piston [B].
- ★ If a master cylinder or piston shows any damage, replace them.
- Inspect the primary cup [C] and secondary cup [D].
- ★ If a cup is worn, damaged softened (rotted), or swollen, the piston assembly should be replaced to renew the cups.
- ★ If fluid leakage is noted at the brake lever, the piston assembly should be replaced to renew the cups.

Front Master Cylinder [I]

- Check the dust covers [E] for damage.
- ★ If they are damaged, replace them.
- Check the piston return spring [F] for any damage.
- ★ If the springs are damaged, replace them.
- Check that relief port [G] and supply port [H] are not plugged.
- ★ If the relief port becomes plugged, the brake pads will drag on the disc. Blow the ports clean with compressed air.

Rear Master Cylinder [J]

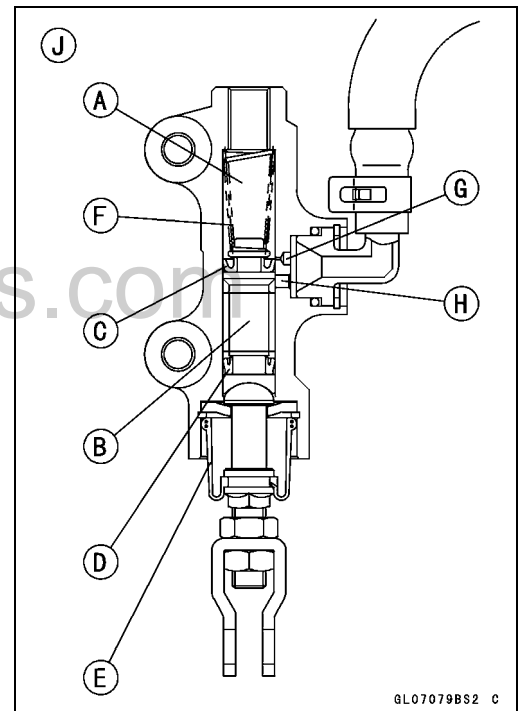
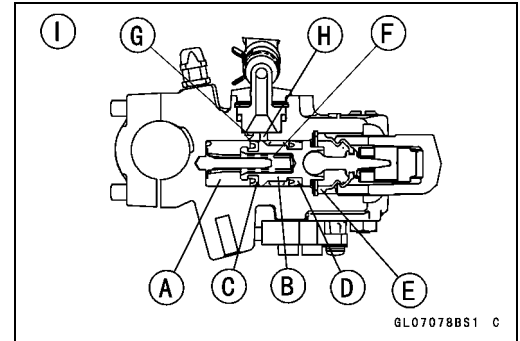

Brake Disc

Brake Disc Removal

- Remove the wheel (see Wheels (Rims) section in the Wheels/Tires chapter).
- Unscrew the mounting bolts, and take off the disc.

Brake Disc Installation

- Install the brake disc on the wheel so that the marked side [B] faces out.
- Apply a non-permanent locking agent to the threads of the rear brake disc mounting bolts [A].
- Tighten:

Torque - Brake Disc Mounting Bolts: 27 N·m (2.8 kgf·m, 20 ft·lb)

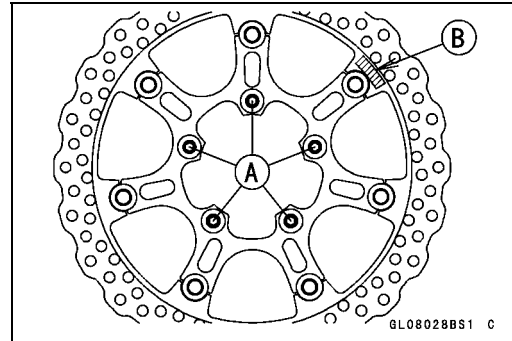

Brake Disc Wear

- Measure the thickness of each disc [A] at the point where it has worn the most.
 - ★ If the disc has worn past the service limit, replace it.
- Measuring Area [B]

Brake Discs Thickness

Standard:

Front 5.8 ~ 6.2 mm (0.23 ~ 0.24 in.)

Rear 4.8 ~ 5.2 mm (0.19 ~ 0.20 in.)

Service Limit:

Front 5.5 mm (0.22 in.)

Rear 4.5 mm (0.18 in.)

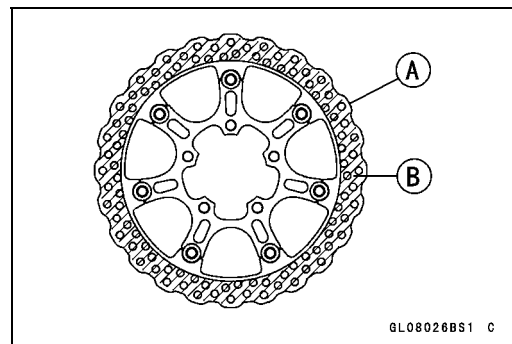

Brake Disc Warp

- Jack up the motorcycle so that the wheel is off the ground.

Special Tools - Jack: 57001-1238

Jack Attachment: 57001-1608

- For front disc inspection, turn the handlebar fully to one side.

- Set up a dial gauge against the disc [A] as shown and measure disc runout, while turning [B] the wheel by hand.

- ★ If runout exceeds the service limit, replace the disc.

Disc Runout

Standard: TIR 0.15 mm (0.006 in.) or less

Service Limit: TIR 0.3 mm (0.01 in.)

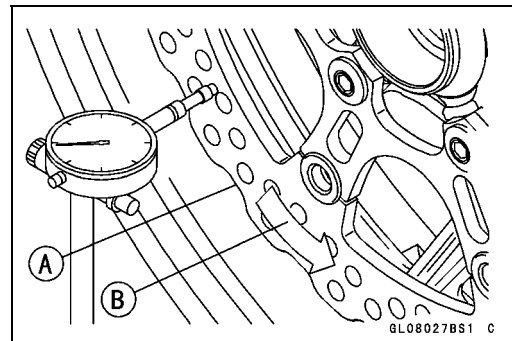

Brake Fluid

Brake Fluid Level Inspection

- Refer to the Brake Fluid Level Inspection in the Periodic Maintenance chapter (see Brake Fluid Level Inspection in the Periodic Maintenance chapter).

Brake Fluid Change

- Refer to the Brake Fluid Change in the Periodic Maintenance chapter (see Brake Fluid Change in the Periodic Maintenance chapter).

Brake Line Bleeding

The brake fluid has a very low compression coefficient so that almost all the movement of the brake lever or pedal is transmitted directly to the caliper for braking action. Air, however, is easily compressed. When air enters the brake lines, brake lever or pedal movement will be partially used in compressing the air. This will make the lever or pedal feel spongy, and there will be a loss in braking power.

⚠ WARNING

Be sure to bleed the air from the brake line whenever brake lever or pedal action feels soft or spongy after the brake fluid is changed, or whenever a brake line fitting has been loosened for any reason.

NOTE

- *The procedure to bleed the front brake line is as follows. Bleeding the rear brake line is the same as for the front brake.*

- Remove:
 - Screw [A]
 - Clamp [B]
 - Front Brake Reservoir Cap [C]
 - Diaphragm Plate
 - Diaphragm
- Fill the reservoir with fresh brake fluid to the upper level line in the reservoir.
- With the reservoir cap off, slowly pump the brake lever several times until no air bubbles can be seen rising up through the fluid from the holes at the bottom of the reservoir.
- Bleed the air completely from the master cylinder by this operation.

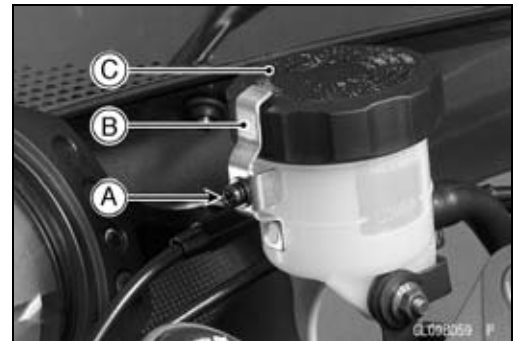

Brake Fluid

- Remove the rubber cap from the bleed valve on the front master cylinder.
- Attach a clear plastic hose [A] to the bleed valve, and run the other end of the hose into a container.



- Bleed the brake line and the master cylinder.
- Repeat this operation until no more air can be seen coming out into the plastic hose.
 1. Pump the brake lever until it becomes hard, and apply the brake and hold it [A].
 2. Quickly open and close [B] the bleed valve while holding the brake applied.
 3. Release the brake [C].

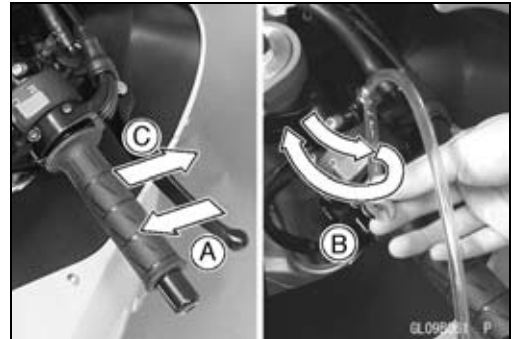

NOTE

○ *The fluid level must be checked often during the bleeding operation and replenished with fresh brake fluid as necessary. If the fluid in the reservoir runs completely out any time during bleeding, the bleeding operation must be done over again from the beginning since air will have entered the line.*

- Remove the clear plastic hose.
- Tighten the bleed valve, and install the rubber cap.

Torque - Front Master Cylinder Bleed Valve: 5.4 N·m (0.55 kgf·m, 48 in·lb)

- Remove the rubber cap [A] from the bleed valve on the caliper.
- Attach a clear plastic hose [B] to the bleed valve, and run the other end of the hose into a container.

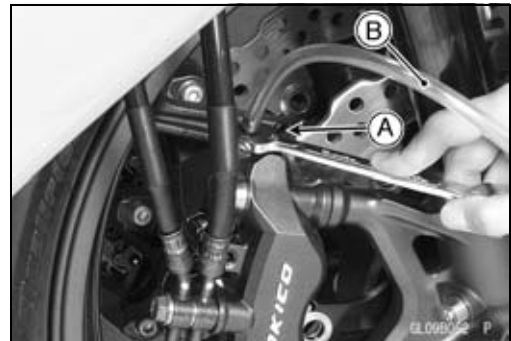

Brake Fluid

- Bleed the brake line and the caliper.
- Repeat this operation until no more air can be seen coming out into the plastic hose.
 1. Pump the brake lever until it becomes hard, and apply the brake and hold it [A].
 2. Quickly open and close [B] the bleed valve while holding the brake applied.
 3. Release the brake [C].

NOTE

- *The fluid level must be checked often during the bleeding operation and replenished with fresh brake fluid as necessary. If the fluid in the reservoir runs completely out any time during bleeding, the bleeding operation must be done over again from the beginning since air will have entered the line.*
 - *Tap the brake hose lightly from the caliper to the reservoir for more complete bleeding.*
 - *Front Brake: First bleeding the right caliper then repeat the above steps for the left caliper.*
- Remove the clear plastic hose.

- Install:
 - Diaphragm [A]
 - Diaphragm Plate [B]
 - Front Brake Reservoir Cap [C]

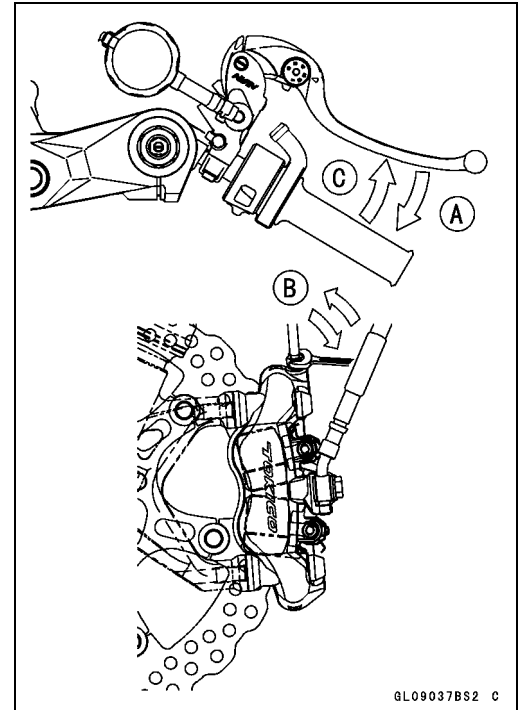

GL09037BS2 C

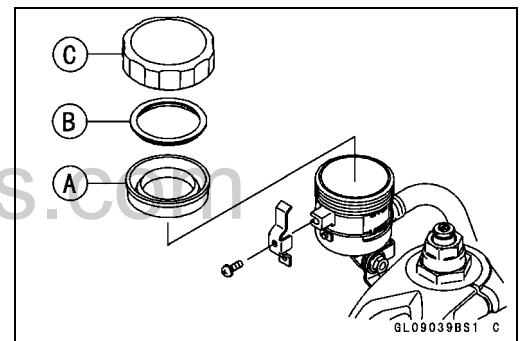

GL09039BS1 C

- Follow the procedure below to install the front/rear brake fluid reservoir cap correctly.
 - First, tighten the brake fluid reservoir cap [B] clockwise [C] by hand until the resistance is felt fully; then, tighten the cap an additional 1/6 turn [D] while holding the brake fluid reservoir body [A].

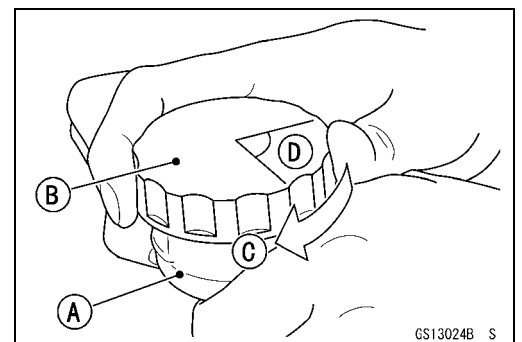

GS13024B S

- Tighten:
 - Torque - Front Brake Reservoir Cap Stopper Screw: 1.2 N·m (0.12 kgf·m, 11 in·lb)**
- Tighten the bleed valve, and install the rubber cap.
 - Torque - Bleed Valve: 7.8 N·m (0.80 kgf·m, 69 in·lb)**
- Check the fluid level (see Brake Fluid Level Inspection in the Periodic Maintenance chapter).
- After bleeding is done, check the brake for good braking power, no brake drag, and no fluid leakage.

Brake Fluid

WARNING

When working with the disc brake, observe the precautions listed below.

1. Never reuse old brake fluid.
2. Do not use fluid from a container that has been left unsealed or that has been open for a long time.
3. Do not mix two types and brands of fluid for use in the brake. This lowers the brake fluid boiling point and could cause the brake to be ineffective. It may also cause the rubber brake parts to deteriorate.
4. Don't leave the reservoir cap off for any length of time to avoid moisture contamination of the fluid.
5. Don't change the fluid in the rain or when a strong wind is blowing.
6. Except for the disc pads and disc, use only disc brake fluid, isopropyl alcohol, or ethyl alcohol for cleaning of the brake parts. Do not use any other fluid for cleaning these parts. Gasoline, engine oil, or any other petroleum distillate will cause deterioration of the rubber parts. Oil spilled on any part will be difficult to wash off completely and will eventually deteriorate the rubber used in the disc brake.
7. When handling the disc pads or disc, be careful that no disc brake fluid or any oil gets on them. Clean off any fluid or oil that inadvertently gets on the pads or disc with a high-flash point solvent. Do not use one which will leave an oily residue. Replace the pads with new ones if they cannot be cleaned satisfactorily.
8. Brake fluid quickly ruins painted surfaces; any spilled fluid should be completely wiped up immediately.
9. If any of the brake line fittings or the bleed valve is opened at any time, the **AIR MUST BE BLED FROM THE BRAKE LINE.**

Brake Hose

Brake Hose Removal/Installation

- Refer to the Brake Hose and Pipe Replacement in the Periodic Maintenance chapter (see Brake Hose and Pipe Replacement in the Periodic Maintenance chapter).

Brake Hose Inspection

- Refer to the Brake Hose Damage and Installation Condition Inspection in the Periodic Maintenance chapter (see Brake Hose Damage and Installation Condition Inspection in the Periodic Maintenance chapter).

www.zxforums.com

www.zxforums.com

Suspension

Table of Contents

Exploded View	13-2
Specifications	13-6
Special Tools	13-7
Front Fork	13-9
Rebound Damping Force Adjustment	13-9
Compression Damping Force Adjustment	13-9
Spring Preload Adjustment	13-10
Front Fork Removal (each fork leg)	13-10
Front Fork Installation	13-11
Front Fork Oil Change	13-11
Front Fork Disassembly	13-17
Front Fork Assembly	13-17
Inner Tube Inspection	13-18
Dust Seal Inspection	13-19
Spring Tension	13-19
Rear Shock Absorber	13-20
Rebound Damping Force Adjustment	13-20
Compression Damping Force Adjustment	13-20
Spring Preload Adjustment	13-20
Rear Shock Absorber Removal	13-21
Rear Shock Absorber Installation	13-22
Rear Shock Absorber Inspection	13-22
Rear Shock Absorber Scrapping	13-22
Swingarm	13-23
Swingarm Removal	13-23
Swingarm Installation	13-24
Swingarm Bearing Removal	13-25
Swingarm Bearing Installation	13-25
Swingarm Bearing, Sleeve Inspection	13-26
Swingarm Pivot Lubrication	13-26
Chain Guide Inspection	13-26
Tie-Rod, Rocker Arm	13-27
Tie-Rod Removal	13-27
Tie-Rod Installation	13-27
Rocker Arm Removal	13-27
Rocker Arm Installation	13-28
Tie-Rod and Rocker Arm Bearing Removal	13-28
Tie-Rod and Rocker Arm Bearing Installation	13-28
Rocker Arm/Tie-Rod Bearing, Sleeve Inspection	13-30
Rocker Arm/Tie-Rod Bearing Lubrication	13-30

Exploded View

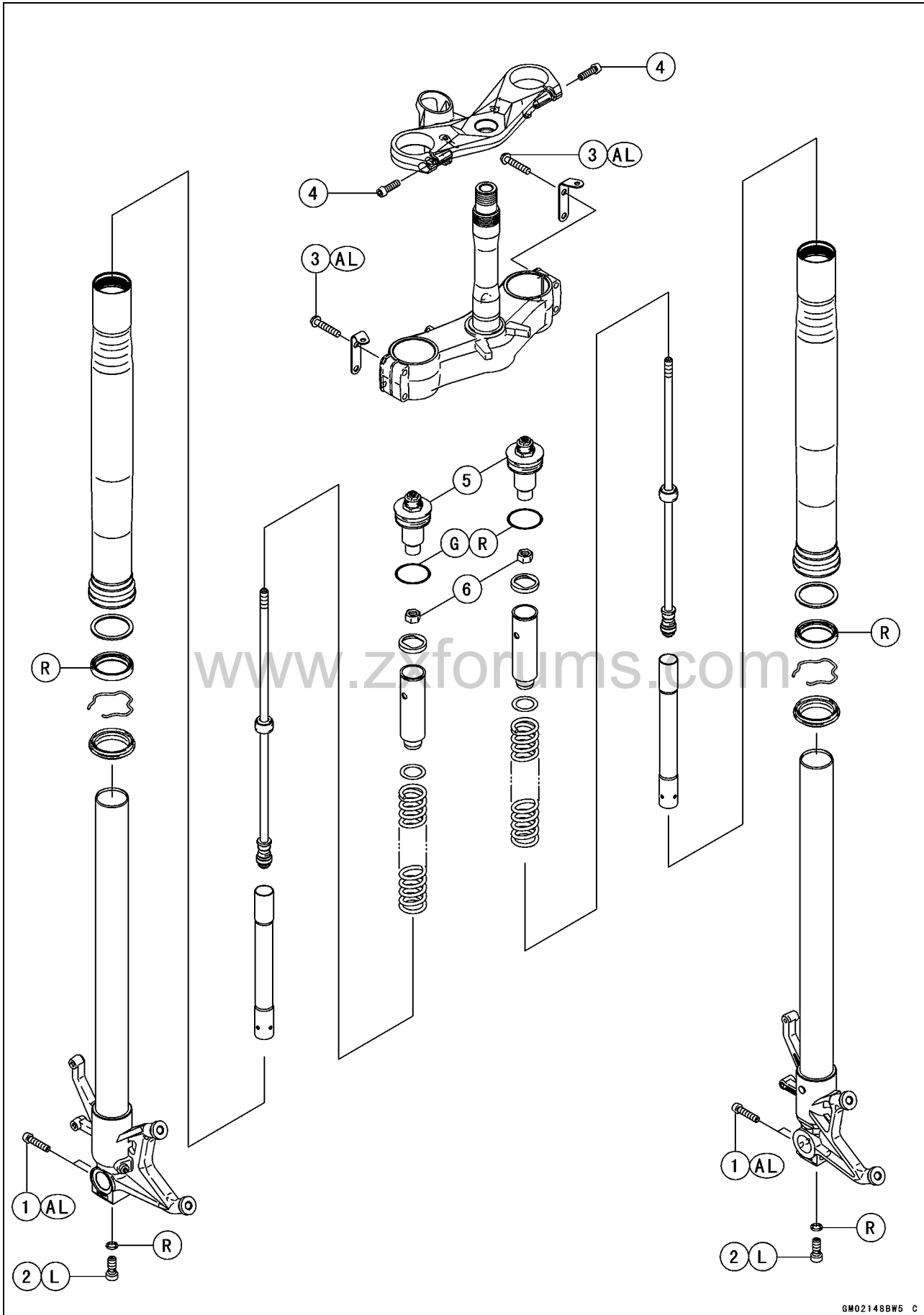

GM02148BW5 C

Exploded View

No.	Fastener	Torque			Remarks
		N·m	kgf·m	ft·lb	
1	Front Axle Clamp Bolts	20	2.0	15	AL
2	Front Fork Bottom Allen Bolts	23	2.3	17	L
3	Front Fork Clamp Bolts (Lower)	30	3.1	22	AL
4	Front Fork Clamp Bolts (Upper)	20	2.0	15	
5	Front Fork Top Plugs	23	2.3	17	
6	Piston Rod Nuts	15	1.5	11	

AL: Tighten the two clamp bolts alternately two times to ensure even tightening torque.

G: Apply grease.

L: Apply a non-permanent locking agent.

R: Replacement Parts

www.zxforums.com

Exploded View

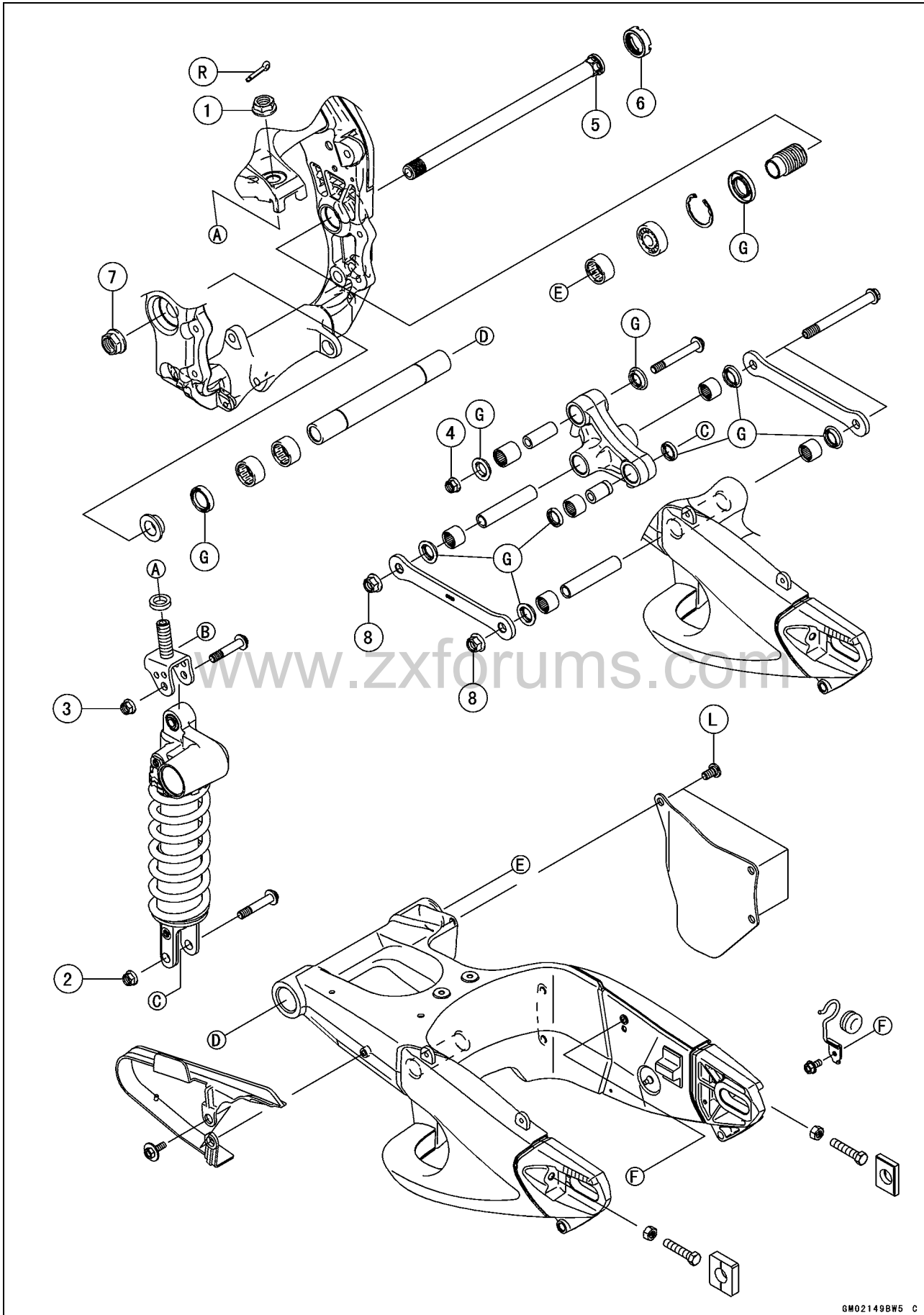

GM02149BW5 C

Exploded View

No.	Fastener	Torque			Remarks
		N·m	kgf·m	ft·lb	
1	Rear Shock Absorber Bracket Nut	59	6.0	44	
2	Rear Shock Absorber Nut (Lower)	34	3.5	25	
3	Rear Shock Absorber Nut (Upper)	34	3.5	25	
4	Uni-Trak Rocker Arm Nut	34	3.5	25	
5	Swingarm Pivot Adjusting Shaft	20	2.0	15	
6	Swingarm Pivot Adjusting Collar Locknut	98	10.0	72	
7	Swingarm Pivot Shaft Nut	108	11.0	80	
8	Tie-Rod Nuts	59	6.0	44	

G: Apply or add grease.

R: Replacement Parts

L: Apply a non-permanent locking agent.

www.zxforums.com

Specifications

Item	Standard
<p>Front Fork (Per One Unit)</p> <p>Fork Inner Tube Diameter</p> <p>Air Pressure</p> <p>Rebound Damper Setting</p> <p>Compression Damper Setting</p> <p>Fork Spring Preload Setting</p> <p>Fork Oil:</p> <p> Viscosity</p> <p> Amount:</p> <p> When Changing Oil</p> <p> After Disassembly and Completely Dry</p> <p>Fork Oil Level: (Fully Compressed, without Spring, below from the Top of the Outer Tube)</p> <p>Fork Spring Free Length</p>	<p>$\phi 43$ mm (1.7 in.)</p> <p>Atmospheric pressure (non-adjustable)</p> <p>10th click from the first click of the fully clockwise position (Usable range: 0 \longleftrightarrow 11 clicks)</p> <p>10th click from the first click of the fully clockwise position (Usable range: 0 \longleftrightarrow 13 clicks)</p> <p>Adjuster protrusion is 17 mm (0.67 in.) (Usable range: 4 ~ 19 mm) (0.16 ~ 0.75 in.)</p> <p>KHL15-10 (KAYABA) or equivalent</p> <p>Approx. 480 mL (16.2 US oz.)</p> <p>567 \pm4 mL (19.2 \pm0.14 US oz.)</p> <p>111 \pm2 mm (4.37 \pm0.08 in.)</p> <p>232.1 mm (9.14 in.) (Service limit: 227 mm (8.94 in.))</p>
<p>Rear Shock Absorber</p> <p>Rebound Damper Set</p> <p>Compression Damper Set</p> <p>Spring Preload Setting Position</p> <p> Standard</p> <p> Usable Range</p> <p>Gas Pressure</p>	<p>2 turns out from the fully clockwise position (Usable range: 0 \longleftrightarrow 2 1/2 turns out)</p> <p>4 turns out from the fully clockwise position (Usable range: 0 \longleftrightarrow 4 turns out)</p> <p>Spring length: 179 mm (7.0 in.)</p> <p>Spring length: 179 ~ 191.5 mm (7.047 ~ 7.539 in.) (weaker to stronger)</p> <p>980 kPa (10 kgf/cm², 142 psi, non-adjustable)</p>

Special Tools

Inside Circlip Pliers:
57001-143

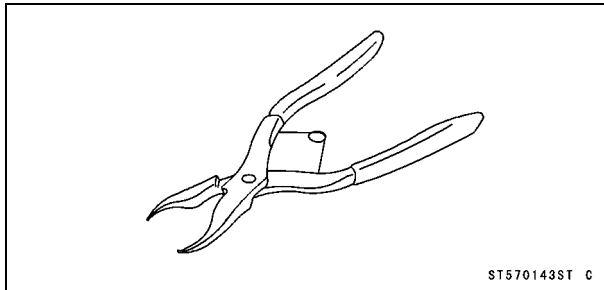

Fork Cylinder Holder:
57001-1287

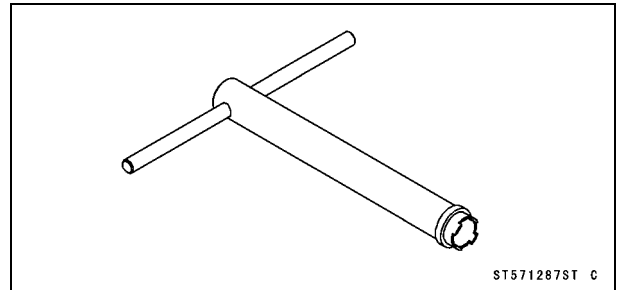

Oil Seal & Bearing Remover:
57001-1058

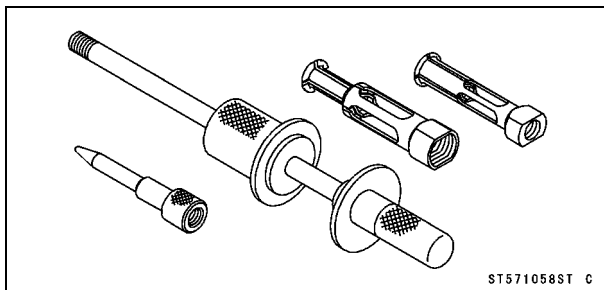

Fork Oil Level Gauge:
57001-1290

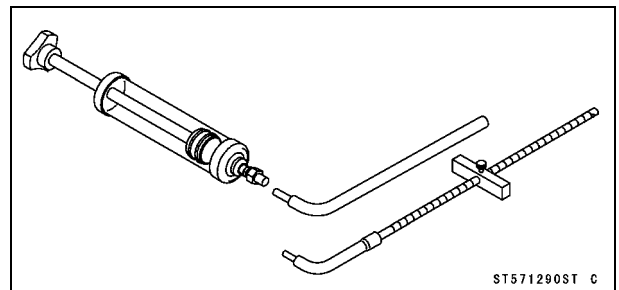

Hook Wrench R37.5, R42:
57001-1101

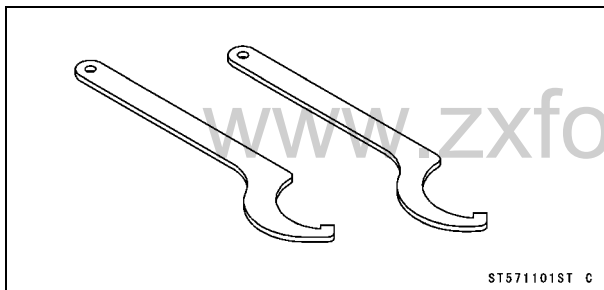

Bearing Remover Head, $\phi 20 \times \phi 22$:
57001-1293

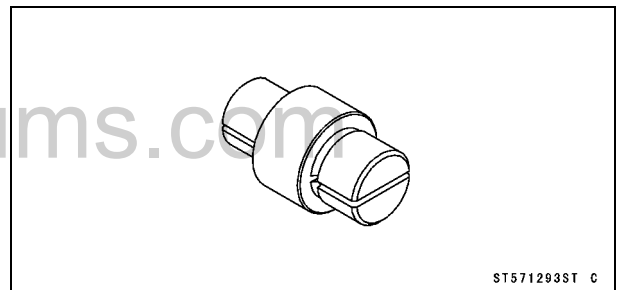

Bearing Driver Set:
57001-1129

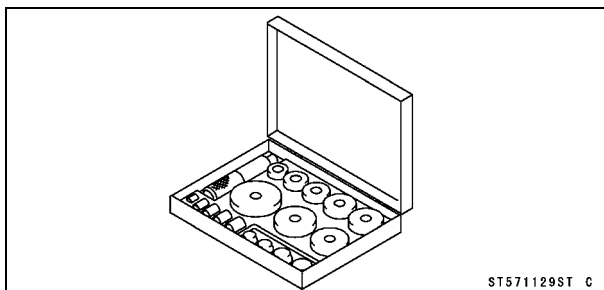

Fork Piston Rod Puller, M10 \times 1.0:
57001-1298

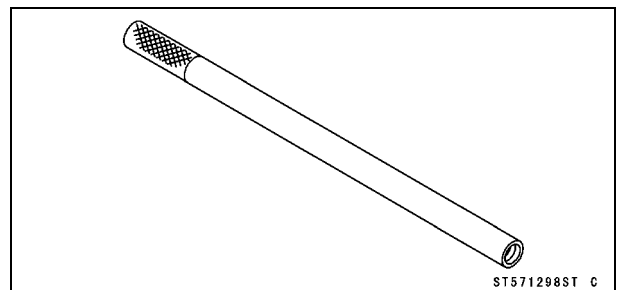

Jack:
57001-1238

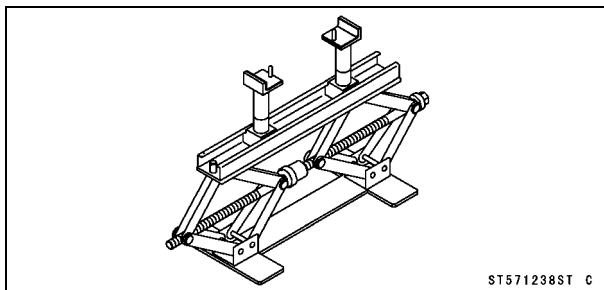

Bearing Remover Shaft, $\phi 13$:
57001-1377

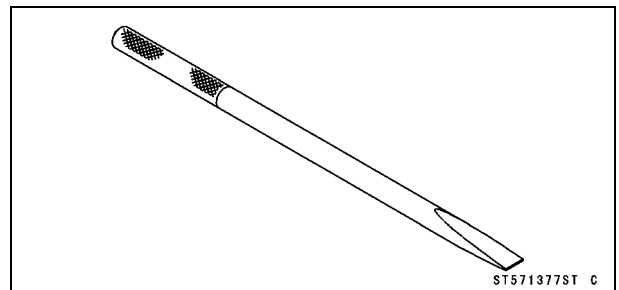

Special Tools

Fork Oil Seal Driver, $\phi 43$:
57001-1530

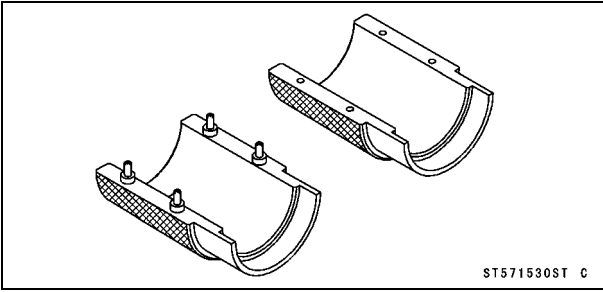

Needle Bearing Driver, $\phi 17/\phi 18$:
57001-1609

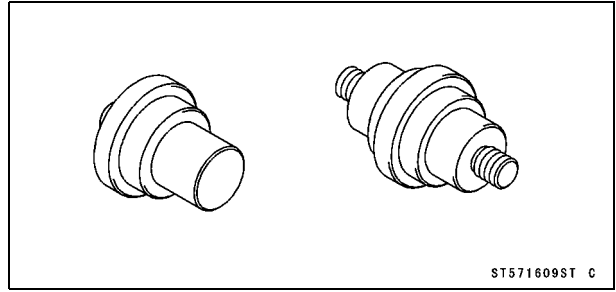

Fork Spring Compressor:
57001-1587

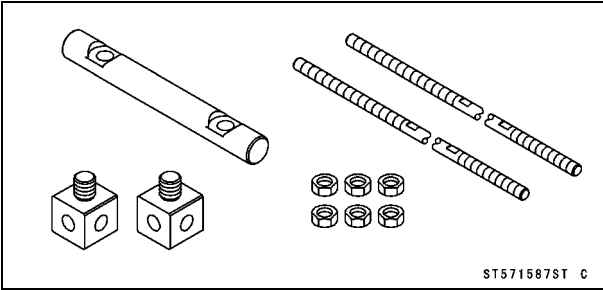

Stem Bearing Driver, $\phi 28$:
57001-1610

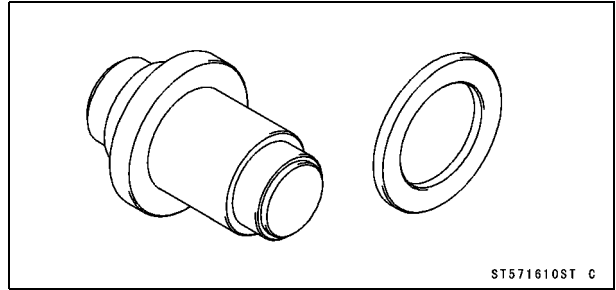

Swingarm Pivot Nut Wrench:
57001-1597

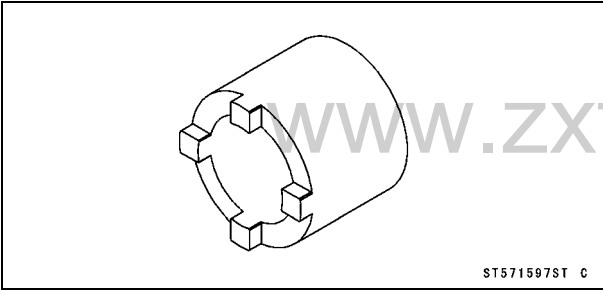

Clamp:
57001-1626

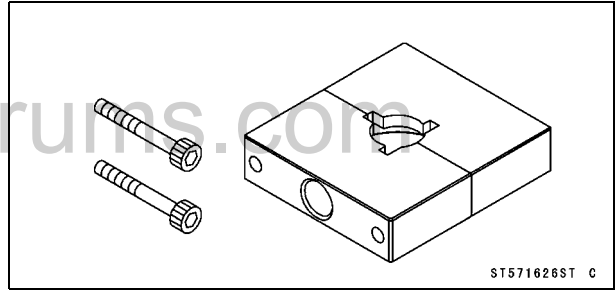

Jack Attachment:
57001-1608

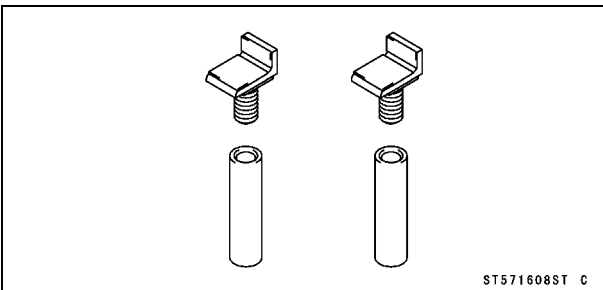

Spacer, $\phi 18$:
57001-1636

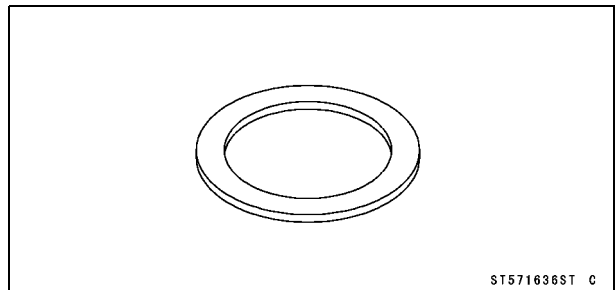

Front Fork

Rebound Damping Force Adjustment

- To adjust the rebound damping force, turn the rebound damping adjuster [A] until you feel a click.
- The standard adjuster setting for the average-build rider of 68 kg (150 lb) with no passenger and no accessories is the **10th click** from the 1st click of the fully clockwise position.

⚠ WARNING

If both adjusters are not adjusted equally, handling may be impaired and a hazardous condition may result.

- The damping force can be left soft for average riding. But it should be adjusted harder for high speed riding or riding with a passenger. If the damping feels too soft or too stiff, adjust it in accordance with the following table.

Rebound Damping Force Adjustment

Adjuster Position	Damping Force	Setting	Load	Road	Speed
11	Weak	Soft	Light	Good	Low
↑	↑	↑	↑	↑	↑
↓	↓	↓	↓	↓	↓
0	Strong	Hard	Heavy	Bad	High

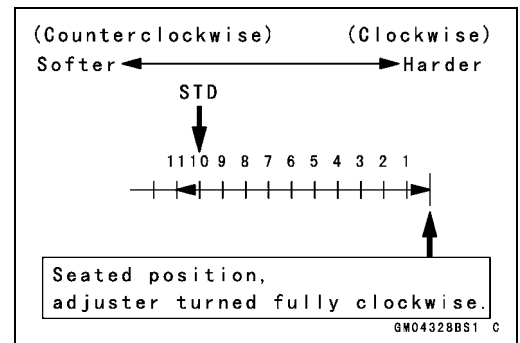
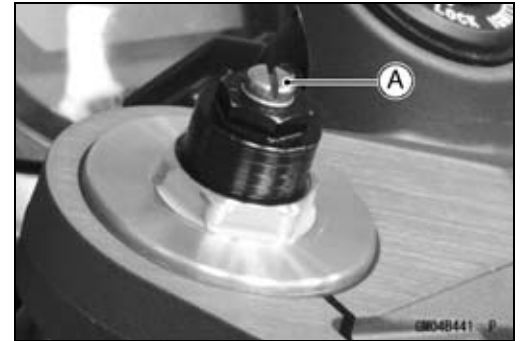

Compression Damping Force Adjustment

- To adjust the compression damping force, turn the compression damping adjuster [A] until you feel a click.
- The standard adjuster setting for the average-build rider of 68 kg (150 lb) with no passenger and no accessories is the **10th click** from the 1st click of the fully clockwise position.

⚠ WARNING

If both adjusters are not adjusted equally, handling may be impaired and a hazardous condition may result.

- The damping force can be left soft for average riding. But it should be adjusted harder for high speed riding or riding with a passenger. If the damping feels too soft or too stiff, adjust it in accordance with the following table.

Compression Damping Force Adjustment

Adjuster Position	Damping Force	Setting	Load	Road	Speed
13	Weak	Soft	Light	Good	Low
↑	↑	↑	↑	↑	↑
↓	↓	↓	↓	↓	↓
0	Strong	Hard	Heavy	Bad	High

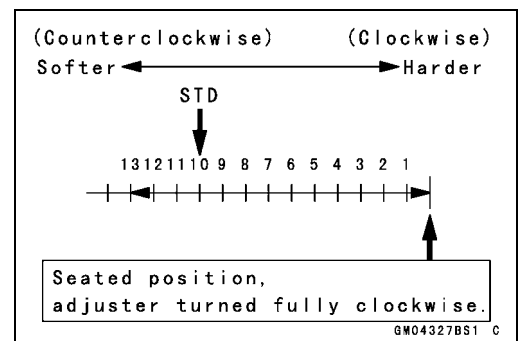

Front Fork

Spring Preload Adjustment

- Turn the spring preload adjuster [A] to change spring preload setting.
- The standard adjuster setting for the average-build rider of 68 kg (150 lb) with no passenger and no accessories is the 17 mm (0.67 in.) [B] from the top plug nut surface as shown.

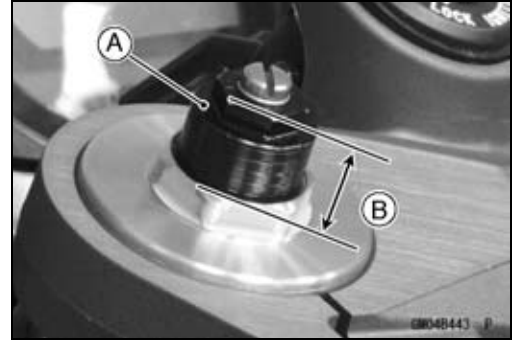

Adjuster Protrusion (from the top plug nut surface)

Standard: 17 mm (0.67 in.)

Usable Range: 4 ~ 19 mm (0.16 ~ 0.75 in.)

⚠ WARNING

If both adjusters are not adjusted equally, handling may be impaired and a hazardous condition may result.

- The spring preload can be left soft for average riding. But it should be adjusted harder for high speed riding or riding with a passenger. If the spring action feels too soft or too stiff, adjust it in accordance with the following table.

Spring Action

Adjuster Position	Damping Force	Setting	Load	Road	Speed
19 mm	Weak	Soft	Light	Good	Low
↑	↑	↑	↑	↑	↑
↓	↓	↓	↓	↓	↓
4 mm	Strong	Hard	Heavy	Bad	High

Front Fork Removal (each fork leg)

- Remove:
 - Front Wheel (see Front Wheel Removal in the Wheels/Tires chapter)
 - Front Fender (see Front Fender Removal in the Frame chapter)
 - Upper Inner Fairings (see Upper Inner Fairing Removal in the Frame chapter)
- ★ Loosen the handlebar bolt [A], upper fork clamp bolt [B] and fork top plug [C] beforehand if the fork leg is to be disassembled.



NOTE

○ Loosen the top plug after loosening the handlebar bolt and upper fork clamp bolt.

Front Fork

- Loosen the handlebar bolt [A], upper fork clamp bolt [B] and lower fork clamp bolts [C].
- With a twisting motion, work the fork leg down and out.

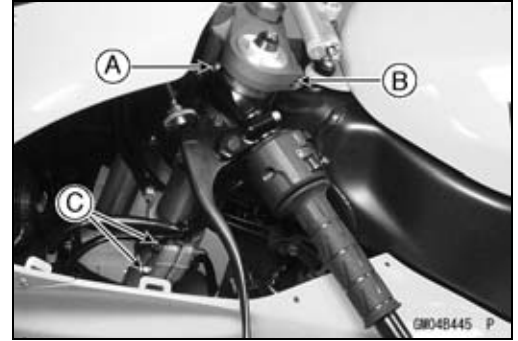

Front Fork Installation

- Install the fork so that the top end [A] of the outer tube is flush with the upper surface [B] of the steering stem head bracket.
- Tighten the upper fork clamp bolt and fork top plug.
 - Torque - Front Fork Clamp Bolts (Upper): 20 N·m (2.0 kgf·m, 15 ft·lb)**
 - Front Fork Top Plugs: 23 N·m (2.3 kgf·m, 17 ft·lb)**
- Tighten the handlebar bolts and lower fork clamp bolts.
 - Torque - Handlebar Bolts: 25 N·m (2.5 kgf·m, 18 ft·lb)**
 - Front Fork Clamp Bolts (Lower): 30 N·m (3.1 kgf·m, 22 ft·lb)**

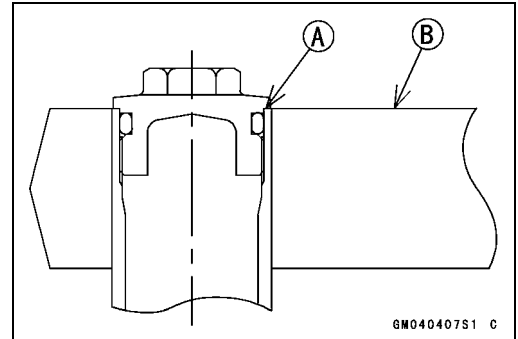

NOTE

- Tighten the two clamp bolts alternately two times to ensure even tightening torque.
- Tighten the top plug before tightening the handlebar holder bolt upper fork clamp bolt.
- Install the removed parts (see appropriate chapters).
- Adjust the spring preload and the damping force.

Front Fork Oil Change

- Remove the front fork (see Front Fork Removal).
- Hold the inner tube lower end in a vise.
- Unscrew the top plug [A] out of the outer tube.

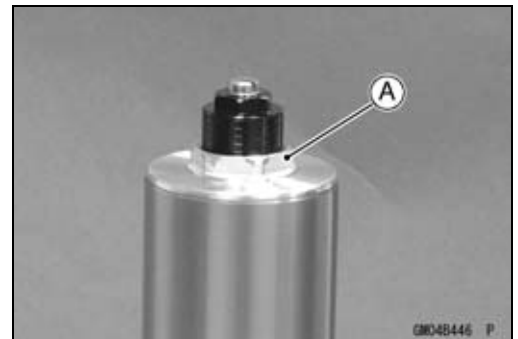

Front Fork

- Install the clamps [A] as shown.

NOTE

○Set the clamps so that the cutout [B] of the upper side does not touch the tongue shape of stopper, pull up the outer tube [C] to hold it by the clamps, and then tighten the two bolts [D]. The outer tube is used as a guide.

Special Tools - Fork Spring Compressor: 57001-1587
Clamp: 57001-1626

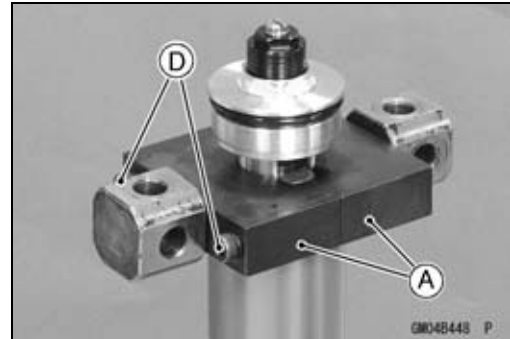
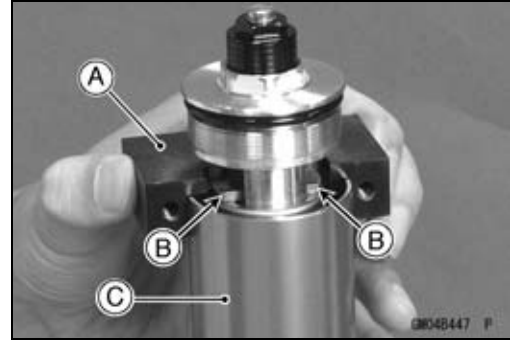

- Insert the holder bar [A] into the axle hole of the front fork [B].

www.zxforums.com

- Insert the compression shaft [A] and install the nut.

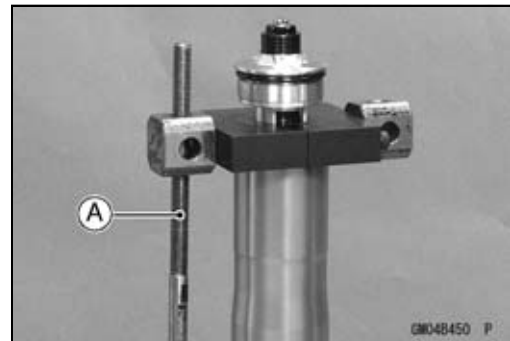
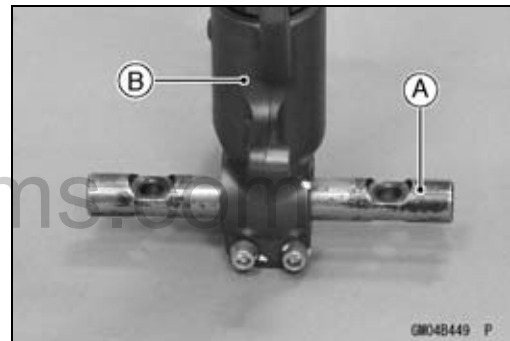

- Insert the lower end of the compression shaft [A] into the hole [B] of the holder bar.

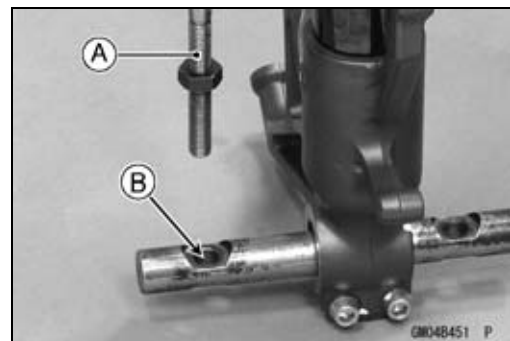

Front Fork

- Screw the adjust nut [A] onto the compression shaft as shown.
20 mm (0.79 in.) [B]
- Screw the locknut [C].
- Set the other side compression shaft same process.

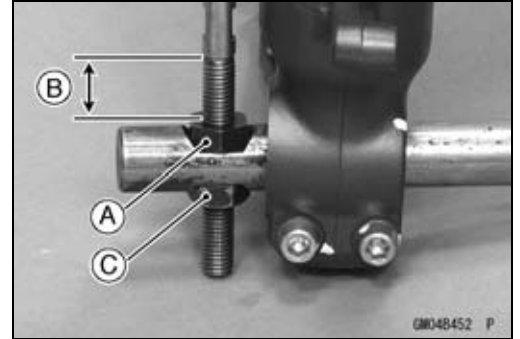

- Screw in one side nut [A] come out the piston rod nut.

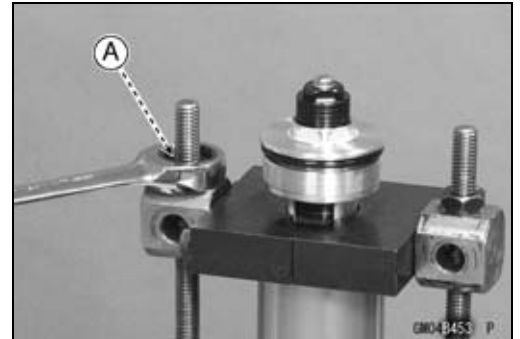

- Holding the piston rod nut with a wrench [A], remove the top plug [B] from the piston rod.

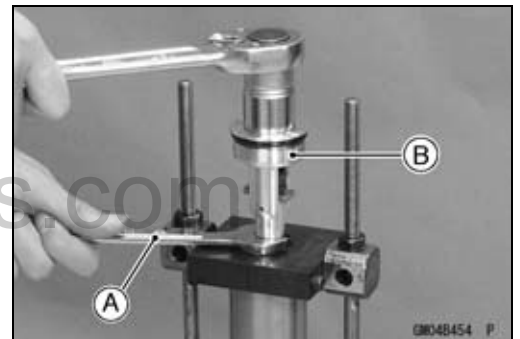

- Remove:
Washer [A]
Collar [B]
Rebound Damping Adjuster Rod [C]
Fork Spring [D]

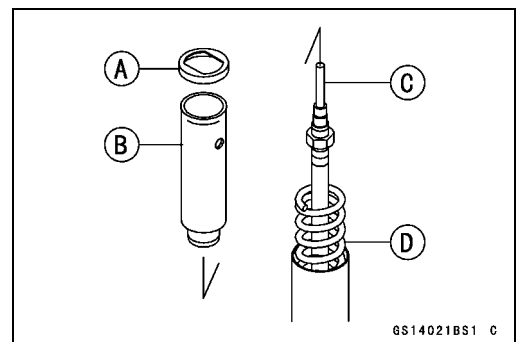

- Drain the fork oil into a suitable container.
- Pump the piston rod [B] up and down at least ten times to expel the oil from the fork.

Special Tool - Fork Piston Rod Puller, M10 × 1.0 [A]: 57001-1298

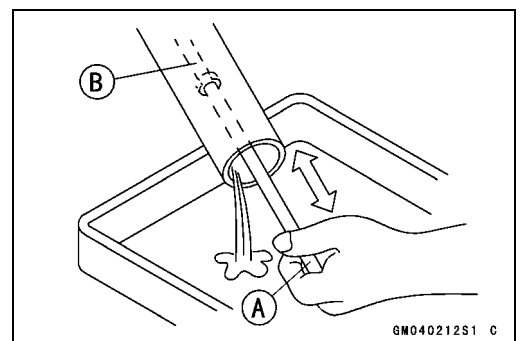

Front Fork

- Hold the fork tube upright, press the inner tube [A] and the piston rod all the way down.
- Pour in the type and amount of fork oil specified.

Fork Oil

Viscosity:

KHL15-10 (KAYABA) or equivalent

Amount (per side):

When changing oil:

Approx. 480 mL (16.2 US oz.)

After disassembly and completely dry:

567 ±4 mL (19.2 ±0.14 US oz.)

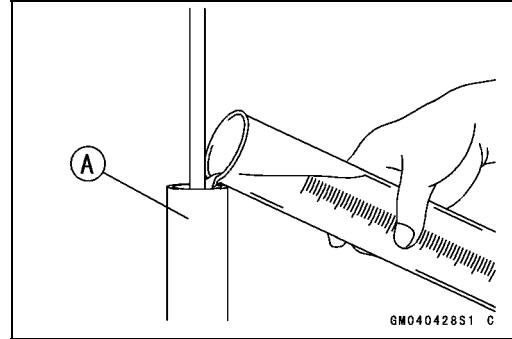

★ If necessary, measure the oil level as follows.

- Hold the inner tube vertically in a vise.
- Using the piston rod puller [A], move the piston rod [B] up and down more than ten times in order to expel all the air from the fork oil.

Special Tool - Fork Piston Rod Puller, M10 × 1.0: 57001-1298

- Remove the piston rod puller.
- Wait until the oil level settles.
- With the fork fully compressed and the piston rod fully pushed in, insert a tape measure or rod into the inner tube, and measure the distance from the top of the outer tube to the oil.

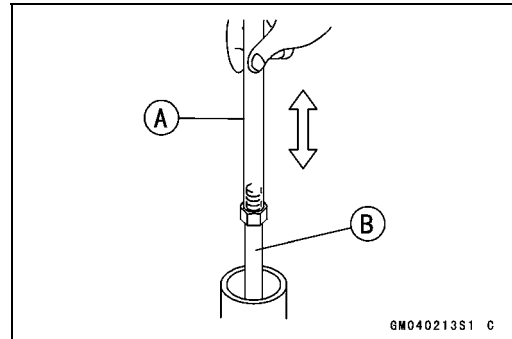

Oil Level (fully compressed, without spring)

Standard: 111 ±2 mm (4.37 ±0.08 in.)

NOTE

○ Fork oil level may also be measured using the fork oil level gauge.

Special Tool - Fork Oil Level Gauge [A]: 57001-1290

- With the fork fully compressed and without fork spring, insert the gauge tube into the inner tube [B] and position the stopper across the top end [F] of the outer tube [C].
- Set the gauge stopper [D] so that its lower side shows the oil level distance specified [E].
- Pull the handle slowly to pump out the excess oil until the oil no longer comes out.
- ★ If no oil is pumped out, there is insufficient oil in the inner tube. Pour in enough oil, then pump out the excess oil as shown above.

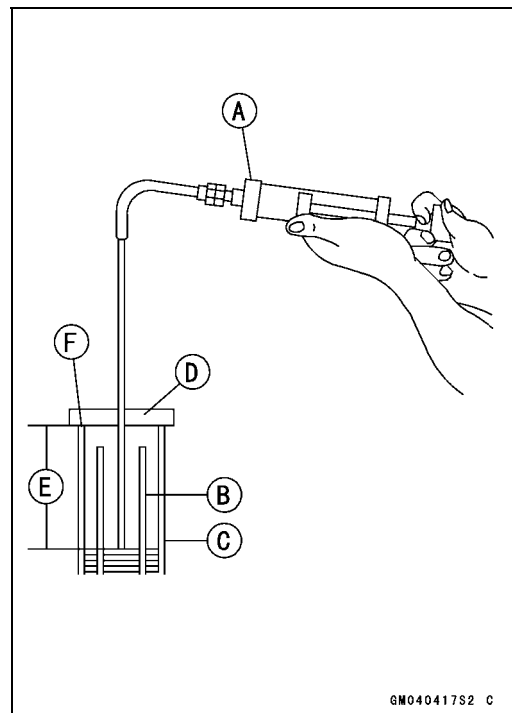

Front Fork

- Screw the fork piston rod puller onto the end of the piston rod.

Special Tool - Fork Piston Rod Puller, M10 × 1.0: 57001-1298

- Pull the puller up above the outer tube top.
- Install the fork spring [A] with the smaller end facing [B] upward.
- Install:
 - Spring Seat
 - Collar
- Screw the rod nut [B] onto the piston rod [A] as shown.
 - 11 mm (0.43 in.) [C]

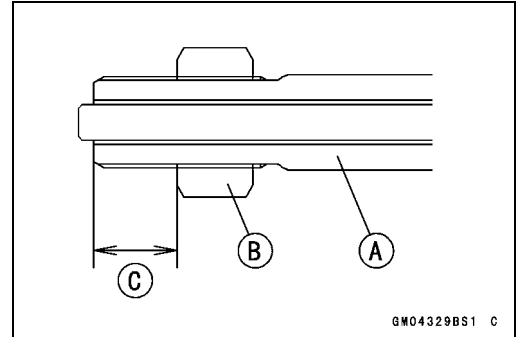
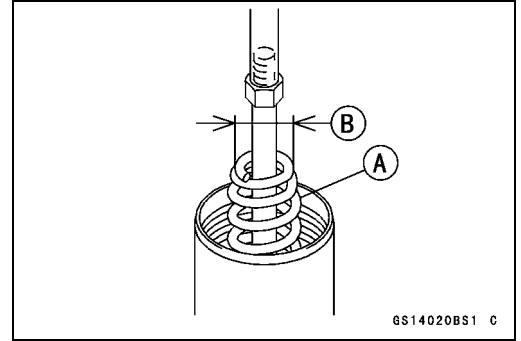

- Check the distance [C] between the bottom end [A] of the top plug and rebound damping adjuster [B] with a pair of vernier caliper.
 - 13 mm (0.51 in.) [C]

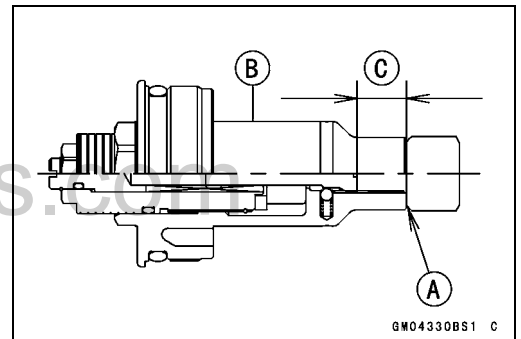

- Set the fork spring compressor on the washer using the outer tube as a guide.

Special Tools - Fork Spring Compressor: 57001-1587
Clamp: 57001-1626

NOTE

- Set the clamps so that the cutout [A] of the upper side does not fit the hole [B] of washer [C], pull up the outer tube [D] to hold it by the clamps, and then tighten the two bolts [E]. The outer tube is used as a guide.

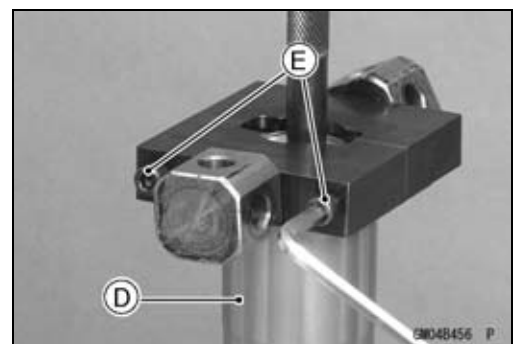
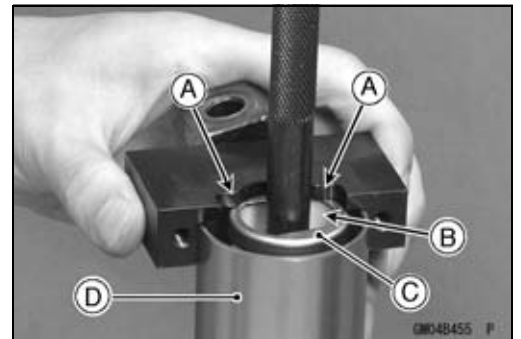

Front Fork

- Set the holder bar [B], and compression shafts [A].

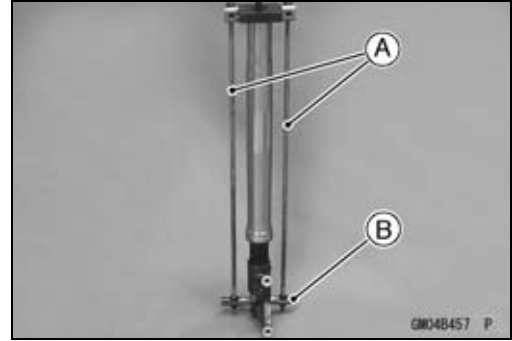

- Hold the piston rod nut [A].
- Remove the piston rod puller [B].

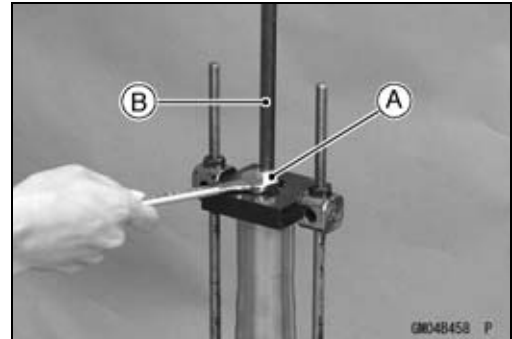

- Install the rebound damping adjuster rod [A].

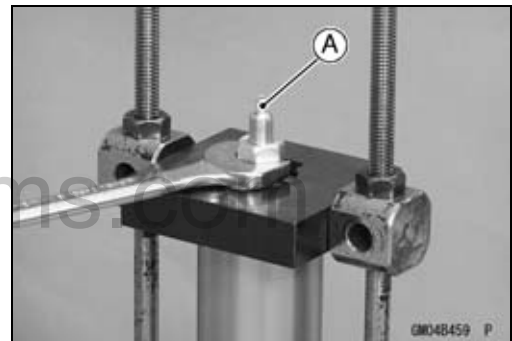

www.zxforums.com

- Screw in the top plug [A] stopped onto the piston rod.
- Check the O-ring [B] on the top plug and replace it with a new one if damaged.
- Holding the top plug with a wrench, tighten the piston rod nut [C] against the top plug.

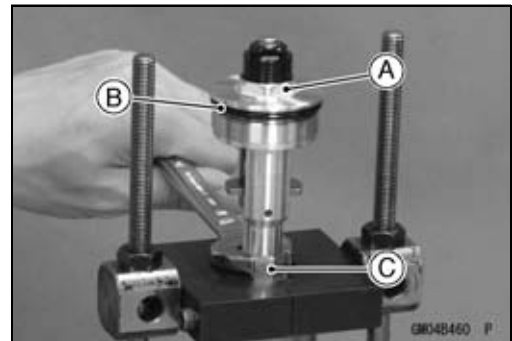

Torque - Piston Rod Nuts: 15 N·m (1.5 kgf·m, 11 ft·lb)

- While holding up the fork spring compressor, pull out the fork spring stopper.
- Remove the fork spring compressor.

- Raise the outer tube and screw the top plug into it and install it to the steering stem.
- Screw in the spring preload adjuster [A] of the top plug so that the distance between the adjuster top and the top plug nut surface is 17 mm (0.67 in.) [B].
- Turn in the rebound damping adjuster until the fully tightened position and turn backward the 10th click.
- Install the front fork (see Front Fork Installation).

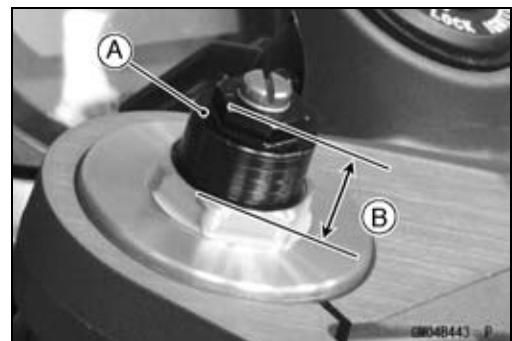

Front Fork

Front Fork Disassembly

- Remove the front fork (see Front Fork Removal).
- Drain the fork oil (see Front Fork Oil Change).
- Hold the front fork in a vise [A].
- Stop the cylinder [B] from turning by using the fork cylinder holder [C].

Special Tool - Fork Cylinder Holder: 57001-1287

- Unscrew the Allen bolt [D], then take the bolt and gasket out of the bottom of the inner tube.

- Take the cylinder unit [A].
- Do not disassemble the cylinder unit.

- Separate the outer tube from the inner tube.
- Pull out the dust seal.
- Remove the retaining ring [A] from the outer tube.
- Remove the oil seal [B] and washer [C].

www.zxforums.com

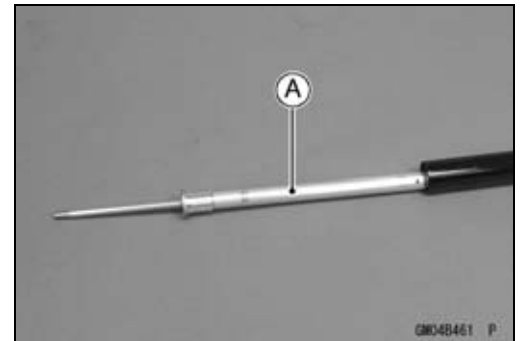
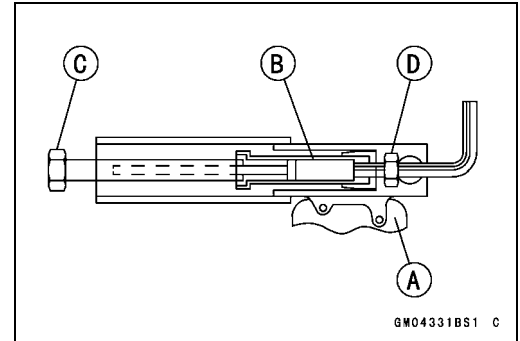

Front Fork Assembly

- Replace the following parts with a new one.
 - Oil Seal
 - Bottom Allen Bolt Gasket

- Insert the cylinder unit [A] into the inner tube [B].
- Stop the cylinder from turning by using the fork cylinder holder.

Special Tool - Fork Cylinder Holder: 57001-1287

- Apply a non-permanent locking agent to the Allen bolt and tighten it.

Torque - Front Fork Bottom Allen Bolts: 23 N·m (2.3 kgf·m, 17 ft·lb)

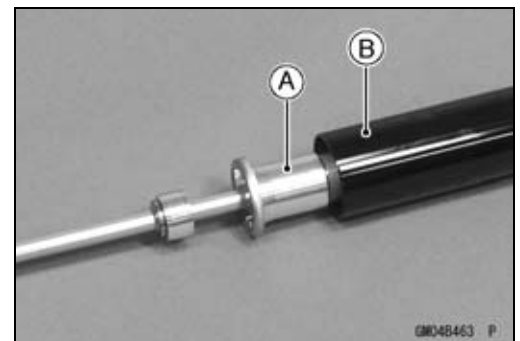

Front Fork

- Install the following parts into the inner tube [A].
 - Dust Seal [B]
 - Circlip [C]
 - Oil Seal [D]
 - Washer [E]

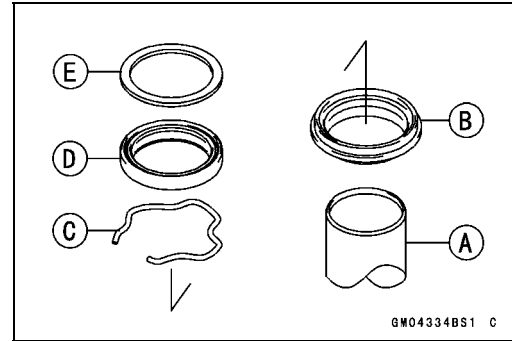

- Insert the inner tube to the outer tube.
- After installing the washer, install the oil seal [A] by using the fork oil seal driver [B].

Special Tool - Fork Oil Seal Driver, ϕ 43: 57001-1530

- Install the circlip and dust seal.
- Pour in the specified type of oil (see Front Fork Oil Change).

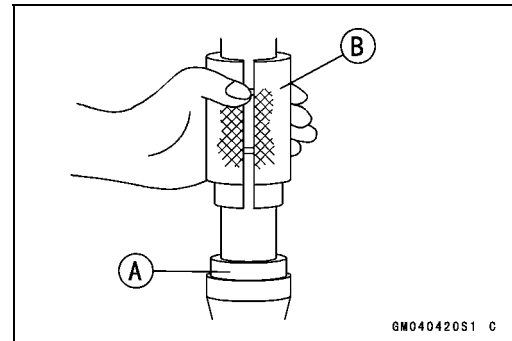

Inner Tube Inspection

- Visually inspect the inner tube [A], and repair any damage.
- Nicks or rust damage can sometimes be repaired by using a wet-stone to remove sharp edges or raised areas which cause seal damage.
- ★ If the damage is not repairable, replace the inner tube. Since damage to the inner tube damages the oil seal, replace the oil seal whenever the inner tube is repaired or replaced.

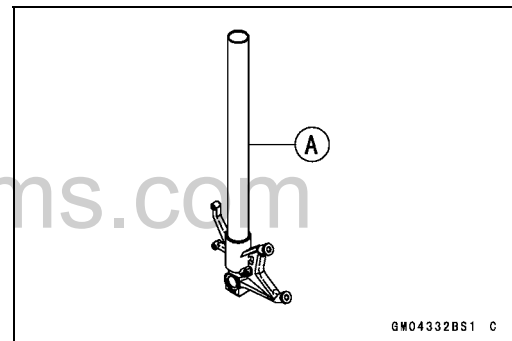

CAUTION

If the inner tube is badly bent or creased, replace it. Excessive bending, followed by subsequent straightening, can weaken the inner tube.

- Temporarily assemble the inner and outer tubes, and pump them back and forth manually to check for smooth operation.
- If you feel binding or catching, the inner and outer tubes must be replaced.

⚠ WARNING

A straightened inner or outer fork tube may fall in use, possibly causing an accident. Replace a badly bent or damaged inner or outer tube and inspect the other tube carefully before reusing it.

Front Fork

Dust Seal Inspection

- Inspect the dust seals [A] for any signs of deterioration or damage.
- ★ Replace it if necessary.

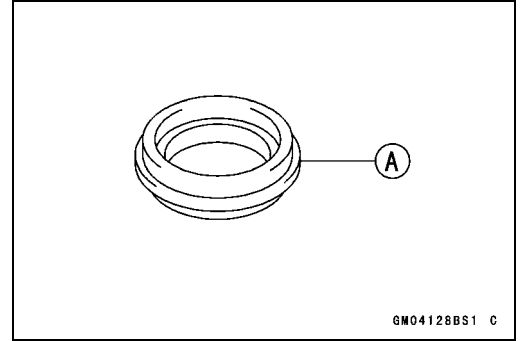

Spring Tension

- Since a spring becomes shorter as it weakens, check its free length [A] to determine its condition.
- ★ If the spring of either fork leg is shorter than the service limit, it must be replaced. If the length of a replacement spring and that of the remaining spring vary greatly, the remaining spring should also be replaced in order to keep the fork legs balanced for motorcycle stability.

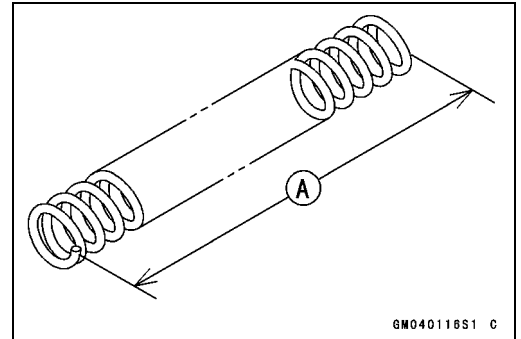

Spring Free Length

Standard: 232.1 mm (9.14 in.)

Service Limit: 227 mm (8.94 in.)

www.zxforums.com

Rear Shock Absorber

Rebound Damping Force Adjustment

- To adjust the rebound damping force, turn the lower damping adjuster [A] to the desired position, until you feel a click.

- The standard adjuster setting for an average-build rider of 68 kg (150 lb) with no passenger and no accessories is the **2 turns out** from the fully clockwise position.

Rebound Damping Force Adjustment

Adjuster Position	Damping Force	Setting	Load	Road	Speed
2 1/2 Turns Out	Weak	Soft	Light	Good	Low
↑	↑	↑	↑	↑	↑
↓	↓	↓	↓	↓	↓
0	Strong	Hard	Heavy	Bad	High

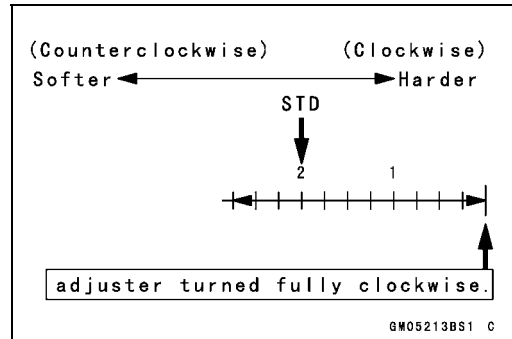
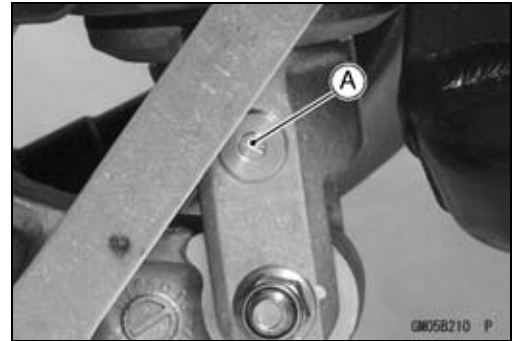

Compression Damping Force Adjustment

- To adjust the compression damping force, turn the upper damping adjuster [A] to the desired position until you feel a click.

- The standard adjuster setting for the average-build rider of 68 kg (150 lb) with no passenger and no accessories is the **4 turns out** from the fully clockwise position.

Rebound Damping Force Adjustment

Adjuster Position	Damping Force	Setting	Load	Road	Speed
4 Turns Out	Weak	Soft	Light	Good	Low
↑	↑	↑	↑	↑	↑
↓	↓	↓	↓	↓	↓
0	Strong	Hard	Heavy	Bad	High

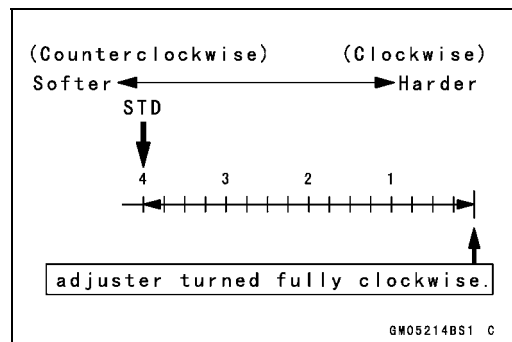

Spring Preload Adjustment

- Loosen the locknut and turn out the adjusting nut to free the spring.

Special Tool - Hook Wrench: 57001-1101

Rear Shock Absorber

- To adjust the spring preload, turn in the adjusting nut [A] to the desired position and tighten the locknut [B].
Spring Length [C]

Spring Preload Setting

Standard: Spring length 179 mm (7.0 in.)

Usable Range: Spring length 179 ~ 191.5 mm (7.047 ~ 7.539 in.)

- The standard adjusting nut setting for an average-build rider of 68 kg (150 lb) with no passenger and no accessories is 180 mm (7.0 in.) spring length.

- Remove the bolts [A], chain cover [B] and left foot guard [C] for turning the hook wrench easily.

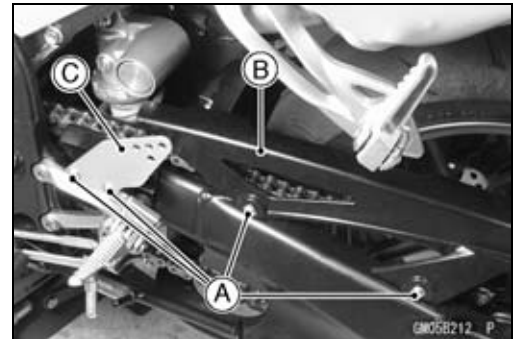
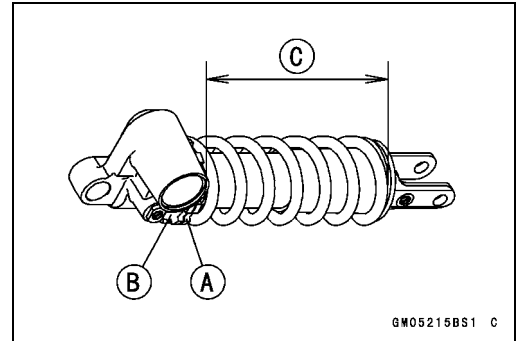

- To adjust the spring preload, turn in the adjusting nut to the desired position and tighten the locknut using by hook wrenches [A] with the rear shock absorber attached the frame.

Special Tool - Hook Wench: 57001-1101

- ★ If the spring action feels too soft or too stiff, adjust it.

Spring Adjustment

Adjuster Position	Damping Force	Setting	Load	Road	Speed
191.5 mm (7.539 in.)	Weak	Soft	Light	Good	Low
↑	↑	↑	↑	↑	↑
↓	↓	↓	↓	↓	↓
179 mm (7.047 in.)	Strong	Hard	Heavy	Bad	High



Rear Shock Absorber Removal

- Remove:
 - Lower Fairings (see Lower Fairing Removal in the Frame chapter)
 - Middle Exhaust Pipe (see Middle and Rear Exhaust Pipe Removal in the Engine Top End chapter)
- Using the jack, raise the rear wheel off the ground.

Special Tools - Jack: 57001-1238

Jack Attachment: 57001-1608

Rear Shock Absorber

- Squeeze the brake lever slowly and it with a band [A].

⚠ WARNING

Be sure to hold the front brake when removing the shock absorber, or the motorcycle may fall over. It could cause an accident and injury.



- Remove:
 - Lower Shock Absorber Nut and Bolt [A]
 - Upper Tie-Rod Nut and Bolt [B]
 - Upper Shock Absorber Nut and Bolt [C]
- Remove the shock absorber downward.

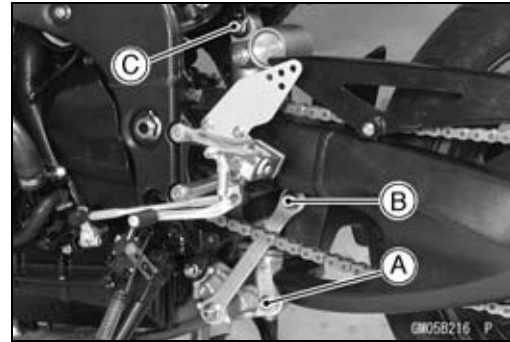

Rear Shock Absorber Installation

- Tighten:
 - Torque - Rear Shock Absorber Nuts: 34 N·m (3.5 kgf·m, 25 ft·lb)
 - Tie-Rod Nuts: 59 N·m (6.0 kgf·m, 44 ft·lb)

Rear Shock Absorber Inspection

- Remove the rear shock absorber.
- Visually inspect the following items.
 - Smooth Stroke
 - Oil Leakage
 - Crack or Dent
- ★ If there is any damage to the rear shock absorber, replace it.
- Visually inspect the rubber bushing.
- ★ If it show any signs of damage, replace it.

Rear Shock Absorber Scrapping

⚠ WARNING

Since the reservoir tank of the rear shock absorber contains nitrogen gas, do not incinerate the reservoir tank without first releasing the gas or it may explode.

- Remove the valve cap and release the nitrogen gas completely from the gas reservoir.
- Remove the valve [A].

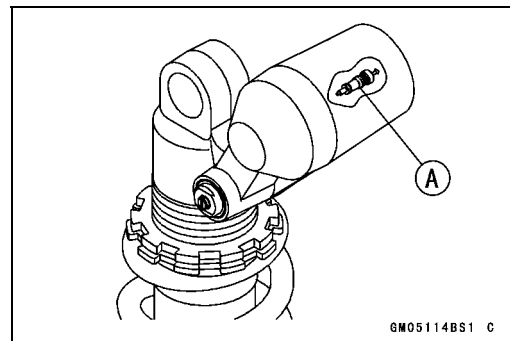

⚠ WARNING

Since the high pressure gas is dangerous, do not point the valve toward your face or body.

Swingarm

Swingarm Removal

- Remove:
 - Rear Wheel (see Rear Wheel Removal in the Wheels/Tires chapter)
 - Middle Exhaust Pipe (see Middle and Rear Exhaust Pipe Removal in the Engine Top End chapter)
 - Engine Sprocket (see Engine Sprocket Removal in the Final Drive chapter)
 - Bolts [A]
 - Chain Cover [B]
 - Inner Fender [C]

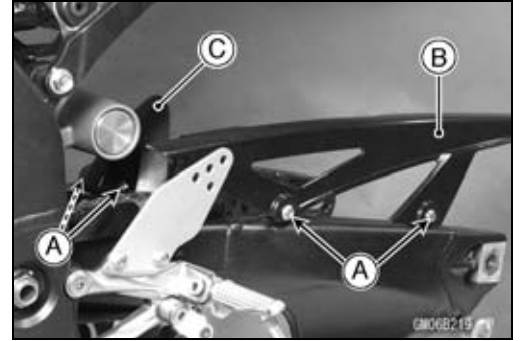

- Remove:
 - Bolt [A]
 - Brake Hose Clamp [B]

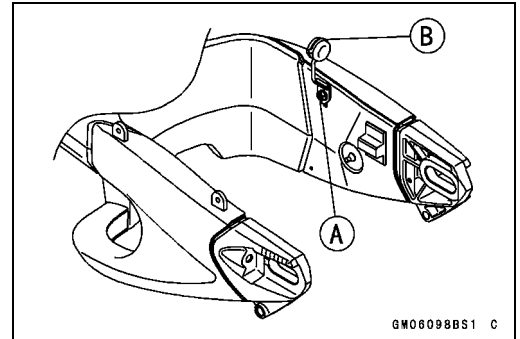

- Remove:
 - Upper Tie-Rod Nut and Bolt [A]
 - Rear Shock Absorber [B] (see Rear Shock Absorber Removal)
- Unscrew the swingarm pivot shaft nut [C].

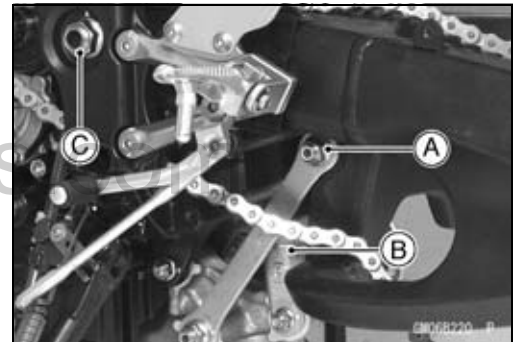

- Loosen the swingarm pivot collar locknut [A] using the nut wrench [B].

Special Tool - Swingarm Pivot Nut Wrench: 57001-1597

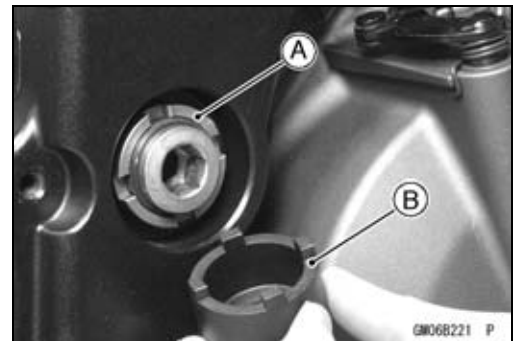

- Unscrew the swingarm pivot shaft [A] few times.
- Turn out the swingarm pivot adjusting collar.
- Pull out the pivot shaft from the right side of the motorcycle and remove the swingarm.

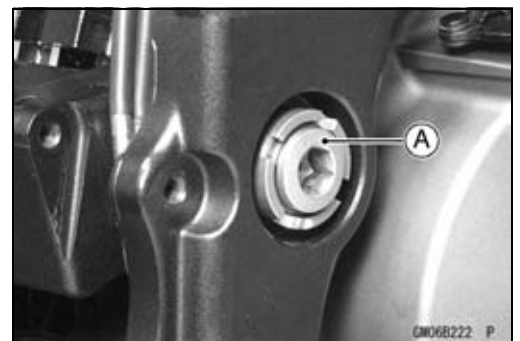

Swingarm

Swingarm Installation

- Apply plenty of grease to the lip [A] of the oil seals.
- Install the collar.

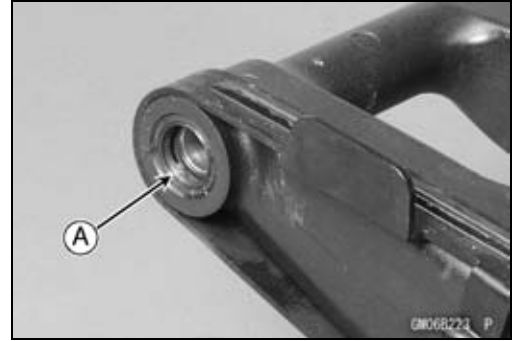

- Place the adjusting collar [A] into the frame [B] as shown.

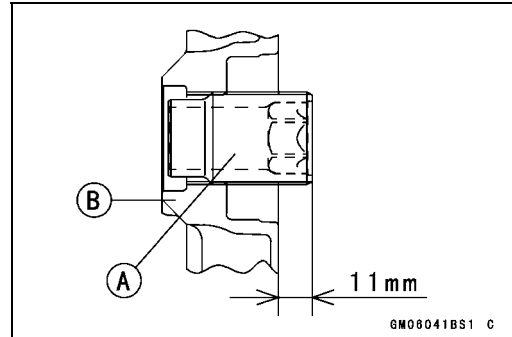

- Insert the pivot adjusting shaft [A] into the frame from the right side.
- Tighten the pivot shaft so that the clearance between the adjusting collar [B] and the ball bearing [C] come to 0 mm (0 in.).

Torque - Swingarm Pivot Adjusting Shaft: 20 N·m (2.0 kgf·m, 15 ft·lb)

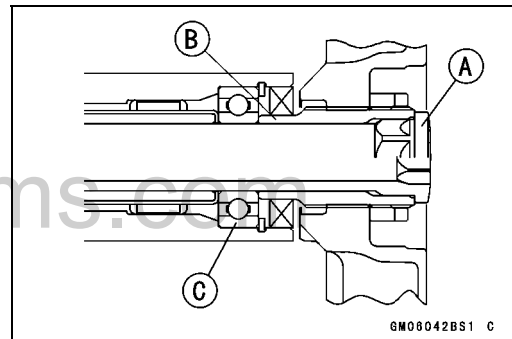

- Tighten the adjusting collar locknut [A] with the swingarm pivot nut wrench [B].

Special Tool - Swingarm Pivot Nut Wrench: 57001-1597

Torque - Swingarm Pivot Adjusting Collar Locknut: 98 N·m (10.0 kgf·m, 72 ft·lb)

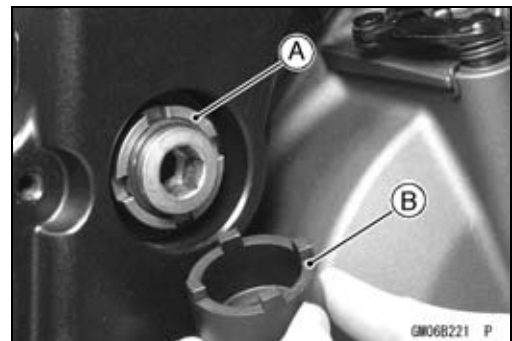

- Tighten the swingarm pivot shaft nut [A].
- Torque - Swingarm Pivot Shaft Nut: 108 N·m (11.0 kgf·m, 80 ft·lb)**

- Install the removed parts (see appropriate chapters).

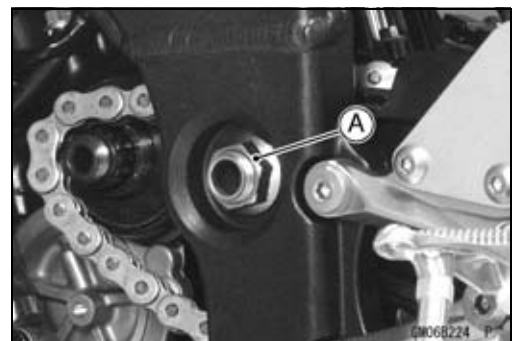

Swingarm

Swingarm Bearing Removal

- Remove:
 - Swingarm (see Swingarm Removal)
 - Collar [A]
 - Oil Seals [B]
 - Sleeve [C]
 - Circlip (Right Side) [D]

Special Tool - Inside Circlip Pliers: 57001-143

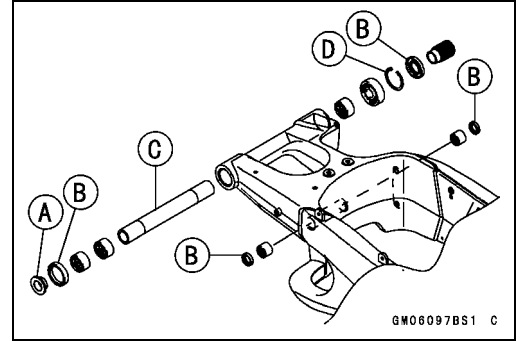

- Remove the ball bearing and needle bearings.

Special Tools - Oil Seal & Bearing Remover [A]: 57001-1058
 Bearing Remover Head: 57001-1293
 Bearing Remover Shaft: 57001-1377

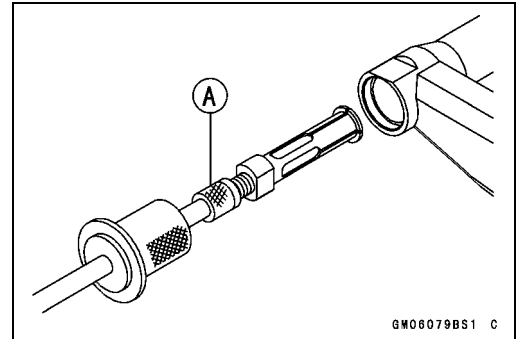

Swingarm Bearing Installation

- Replace the ball and needle bearings with new ones.
- Install the ball and needle bearings so that the manufacturer's marks face out.

Special Tool - Needle Bearing Driver, $\phi 28$: 57001-1610

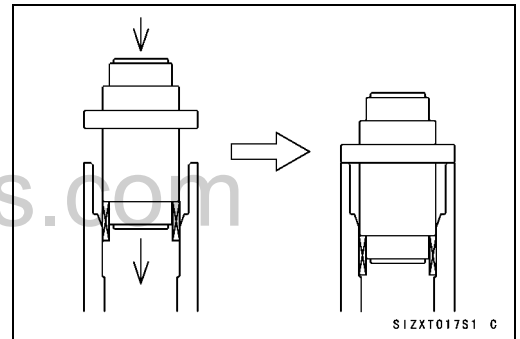

- Install the needle bearings [A], ball bearing [B] and oil seals [C] position as shown.

- Circlip [D]
- 32 mm (1.26 in.) [E]
- 17 mm (0.67 in.) [F]
- 0.5 mm (0.02 in.) [G]
- 1 mm (0.04 in.) [H]
- 10.5 mm (0.41 in.) [I]
- 28 mm (1.10 in.) [J]

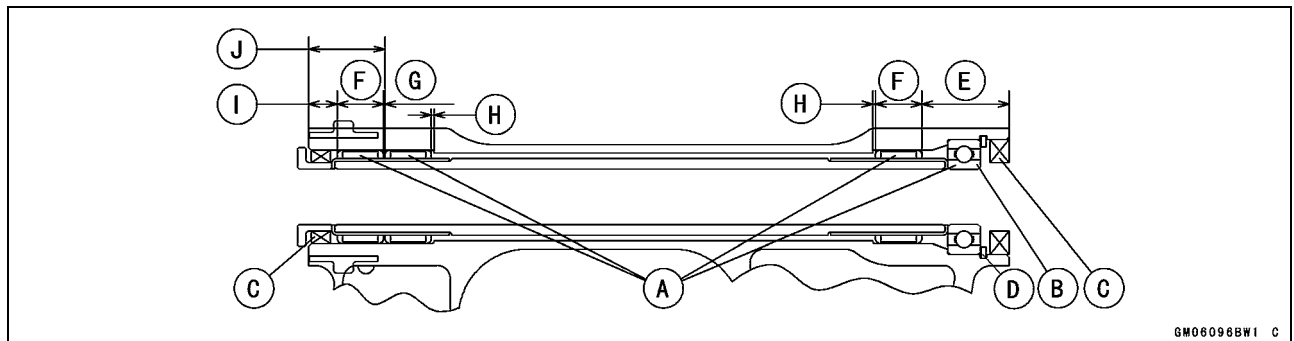

Swingarm

Swingarm Bearing, Sleeve Inspection

CAUTION

Do not remove the bearings for inspection. Removal may damage them.

- Inspect the needle bearings [A] and ball bearing installed in the swingarm.
- The rollers and ball in a bearing normally wear very little, and wear is difficult to measure. Instead of measuring, visually inspect the bearing for abrasion, discoloration, or other damage.
- ★ If the needle bearing, and sleeve show any signs of abnormal wear, discoloration, or damage, replace them as a set.
- Turn the bearing in the swingarm back and forth [A] while checking for plays, roughness, or binding.
- ★ If bearing play, roughness, or binding is found, replace the bearing.
- Examine the bearing seal [B] for tears or leakage.
- ★ If the seal is torn or is leaking, replace the bearing.

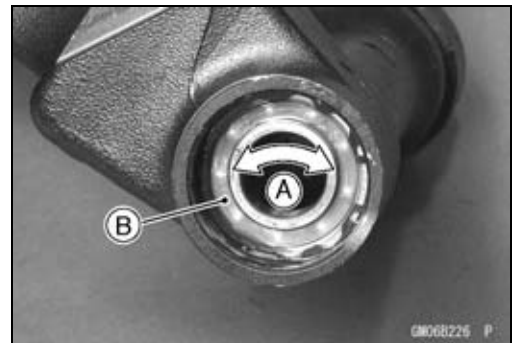
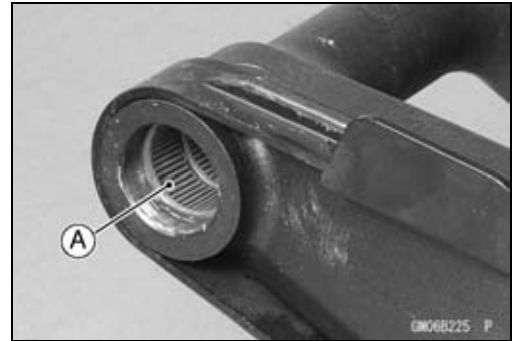

Swingarm Pivot Lubrication

- Refer to the Suspension in the Periodic Maintenance chapter (see Suspension in the Periodic Maintenance chapter).

Chain Guide Inspection

- Visually inspect the chain guide [A].
- ★ Replace the chain slider if it shows any signs of abnormal wear or damage.

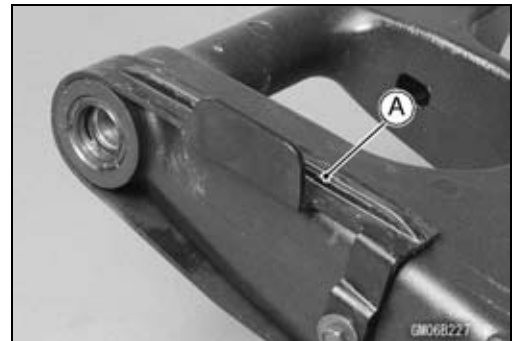

Tie-Rod, Rocker Arm

Tie-Rod Removal

- Remove:
 - Lower Fairings (see Lower Fairing Removal in the Frame chapter)
 - Middle Exhaust Pipe (see Middle and Rear Exhaust Pipe Removal in the Engine Top End chapter)
- Squeeze the brake lever slowly and hold it with a band [A].



- Using the jack, raise the rear wheel off the ground.

Special Tools - Jack: 57001-1238

Jack Attachment: 57001-1608

- Remove:
 - Upper Tie-Rod Bolt and Nut [A]
 - Lower Tie-Rod Bolt and Nut [B]
 - Tie-Rods [C]

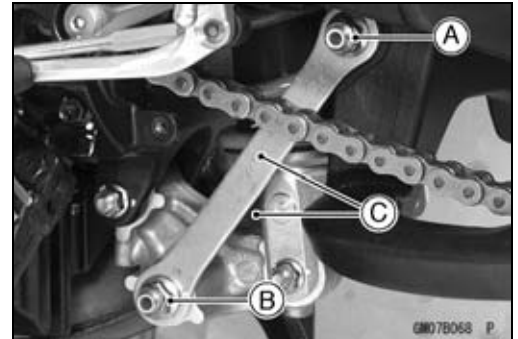

Tie-Rod Installation

- Apply grease to the inside of the oil seals.
- Install the tie-rods so that the marked side [A] faces the bolts and nuts.
- Tighten:
 - Torque - Tie-Rod Nuts: 59 N·m (6.0 kgf·m, 44 ft·lb)

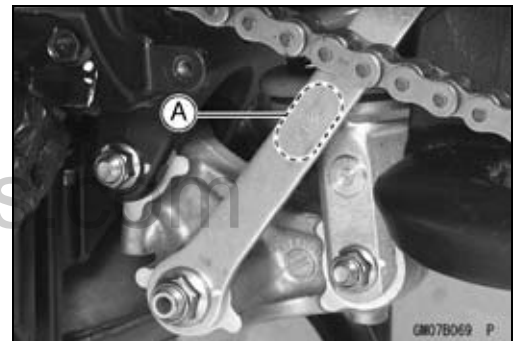

Rocker Arm Removal

- Remove:
 - Lower Fairings (see Lower Fairing Removal in the Frame chapter)
 - Middle Exhaust Pipe (see Middle and Rear Exhaust Pipe Removal in the Engine Top End chapter)
- Squeeze the brake lever slowly and hold it with a band.
- Using the jack, raise the rear wheel off the ground.

Special Tools - Jack: 57001-1238

Jack Attachment: 57001-1608

- Remove:
 - Lower Rear Shock Absorber Bolt and Nut [A]
 - Lower Tie-Rod Bolt and Nut [B]
 - Rocker Arm Bolt and Nut [C]
 - Rocker Arm [D]

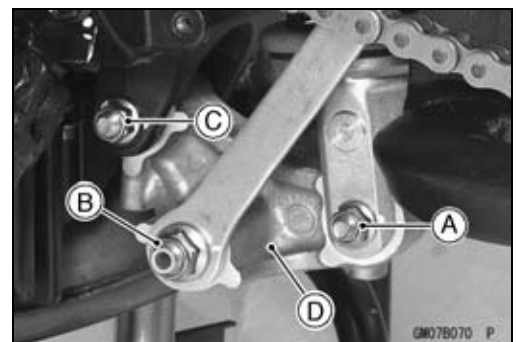

Tie-Rod, Rocker Arm

Rocker Arm Installation

- Apply grease to the inside of the grease seals.
- Tighten:
 - Torque - Uni-Trak Rocker Arm Nut: 34 N·m (3.5 kgf·m, 25 ft·lb)
 - Tie-Rod Nuts: 59 N·m (6.0 kgf·m, 44 ft·lb)
 - Rear Shock Absorber Nuts: 34 N·m (3.5 kgf·m, 25 ft·lb)

Tie-Rod and Rocker Arm Bearing Removal

- Remove:
 - Tie-Rods (see Tie-Rod Removal)
 - Rocker Arm (see Rocker Arm Removal)
 - Sleeves [A]
 - Oil Seal [B]
 - Swingarm [C]
- Remove the needle bearings [D], using the bearing remover head and bearing remover shaft.

Special Tools - Bearing Remover Head: 57001-1293
Bearing Remover Shaft: 57001-1377

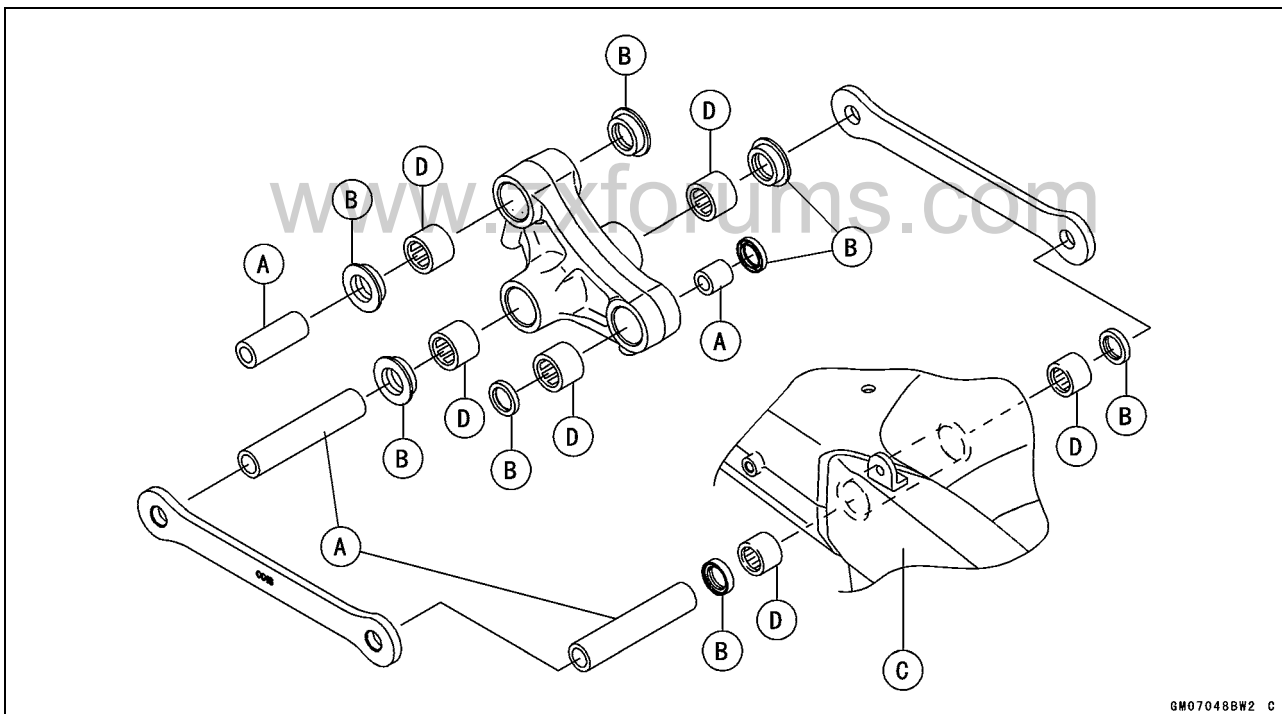

GM070488W2 C

Tie-Rod and Rocker Arm Bearing Installation

- Replace the needle bearing, and oil seals with new ones.
- Apply plenty of grease to the lips of the oil seals.
- Install the needle bearings, and oil seals position as shown.

Tie-Rod, Rocker Arm

- Screw the needle bearing driver [A] into the driver holder [B].
- Insert the needle bearing driver into the needle bearing [C] and press the needle bearing into the housing until the driver contacts the end surface of the housing.
 Bearing's Pressing Depth: 5.5 mm (0.22 in.) [D]
 5.0 mm (0.20 in.) [E]

NOTE

- For a bearing of inner diameter $\phi 18$, select the pressing side of the needle bearing driver according to its pressing depth.

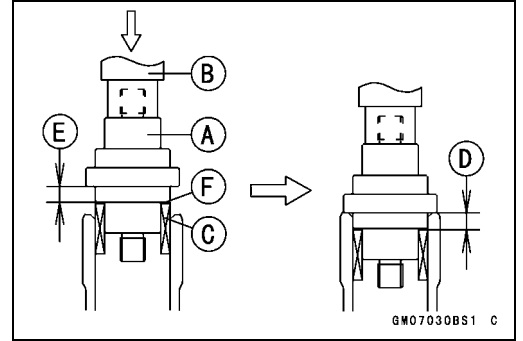

Special Tools - Bearing Driver Set: 57001-1129
Needle Bearing Driver, $\phi 17/\phi 18$: 57001-1609
Spacer, $\phi 18$ [F]: 57001-1636

NOTE

- Install the needle bearings so that the marked side faces out.

- Needle Bearing [A]
- Oil Seals [B]
- Front [C]
- Right Side [D]
- Left Side [E]
- Rear Shock Absorber [F]
- Tie-Rod [G]
- Rocker Arm [H]
- 7.5 mm (0.30 in.) [I]
- 5.0 mm (0.20 in.) [J]
- 5.5 (0.22 in.) [K]

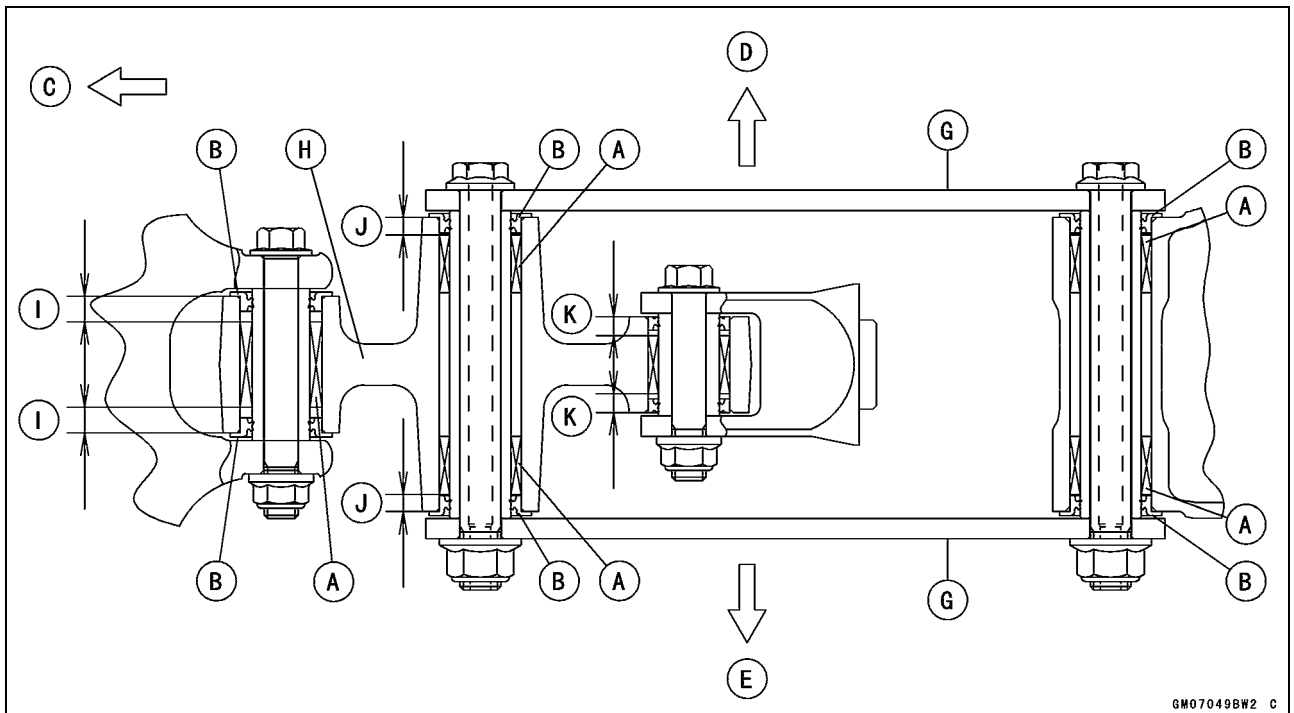

Tie-Rod, Rocker Arm**Rocker Arm/Tie-Rod Bearing, Sleeve Inspection****CAUTION**

Do not remove the bearings for inspection. Removal may damage them.

- Visually inspect the rocker arm, or tie-rod sleeves [A] and needle bearings [B].
- The rollers in a needle bearing normally wear very little, and wear is difficult to measure. Instead of measuring, inspect the bearing for abrasion, color change, or other damage.
- ★ If there is any doubt as to the condition of any of the needle bearings or sleeve, replace the sleeve, and needle bearings as a set.

Rocker Arm/Tie-Rod Bearing Lubrication**NOTE**

○ Since the bearings are packed with grease, lubrication is not required.

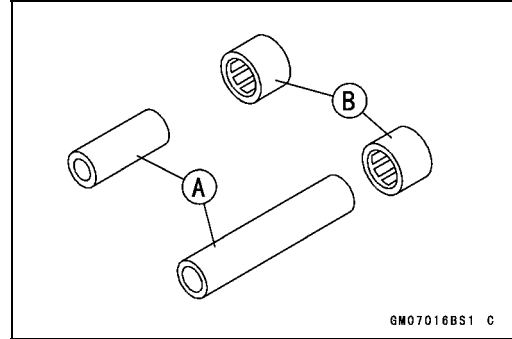

Steering

Table of Contents

Exploded View	14-2
Special Tools	14-5
Steering	14-6
Steering Inspection	14-6
Steering Adjustment.....	14-6
Steering Damper	14-7
Steering Damper Removal.....	14-7
Steering Damper Installation.....	14-7
Damping Force Adjustment	14-7
Steering Damper Oil Leak Inspection	14-7
Steering Stem.....	14-8
Stem, Stem Bearing Removal.....	14-8
Stem, Stem Bearing Installation.....	14-9
Steering Stem Bearing Lubrication	14-12
Steering Stem Warp.....	14-12
Stem Cap Deterioration, Damage.....	14-12
Handlebar	14-13
Handlebar Removal	14-13
Handlebar Installation	14-13

www.zxforums.com

Exploded View

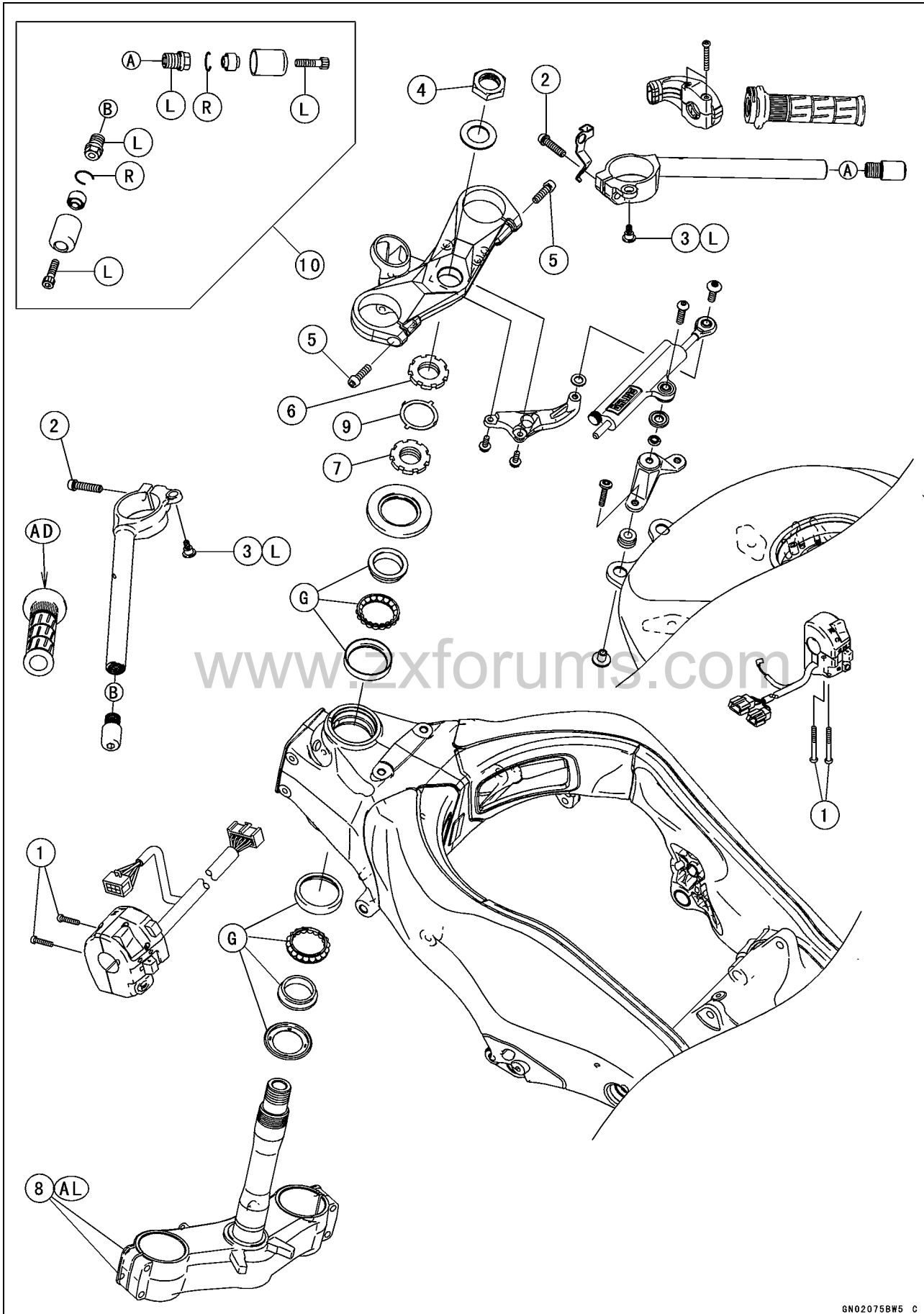

GN02075BW5 C

Exploded View

No.	Fastener	Torque			Remarks
		N·m	kgf·m	ft·lb	
1	Handlebar Switch Housing Screws	3.5	0.36	31 in·lb	
2	Handlebar Bolts	25	2.5	18	
3	Handlebar Position Bolts	9.8	1.0	87 in·lb	L
4	Steering Stem Head Nut	78	8.0	58	
5	Front Fork Clamp Bolts (Upper)	20	2.0	15	
6	Steering Stem Locknut	–	–	–	Hand-tighten
7	Steering Stem Nut	20	2.0	15	
8	Front Fork Clamp Bolts (Lower)	30	3.1	22	AL

9. Lock Washer

10. United States and Canada Models

AD: Apply adhesive.

AL: Tighten the two clamp bolts alternately two times to ensure even tightening torque.

G: Apply grease.

L: Apply a non-permanent locking agent.

R: Replacement Parts

www.zxforums.com

Exploded View

Item	Standard
Steering Damper Damper Set	18 turns out from the fully clockwise position (Usable range: 0 ←→ 18 tuns out)

www.zxforums.com

Special Tools

**Bearing Puller Adapter:
57001-136**

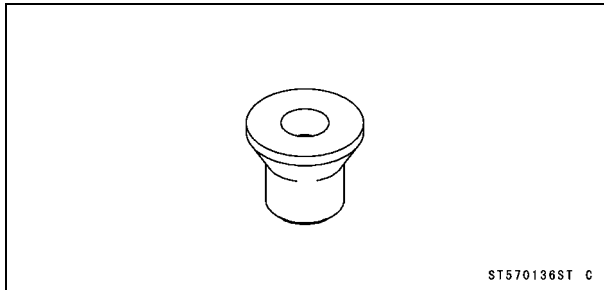

**Bearing Driver Set:
57001-1129**

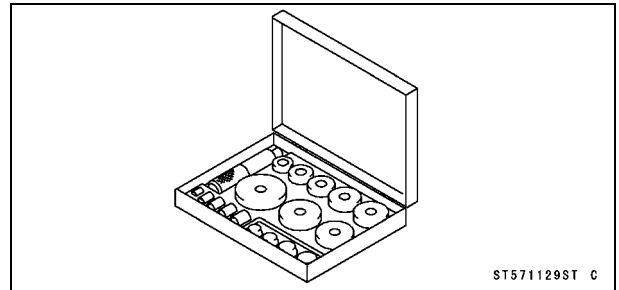

**Bearing Puller:
57001-158**

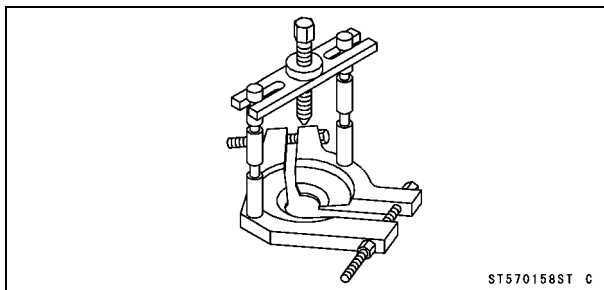

**Steering Stem Bearing Driver, $\phi 42.5$:
57001-1344**

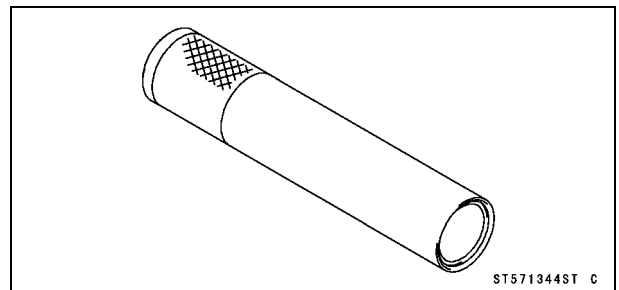

**Head Pipe Outer Race Press Shaft:
57001-1075**

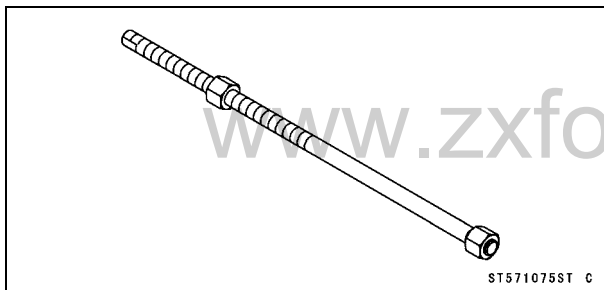

**Steering Stem Bearing Driver Adapter, $\phi 41.5$:
57001-1345**

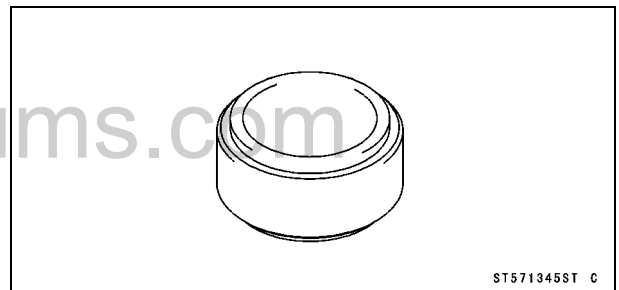

**Steering Stem Nut Wrench:
57001-1100**

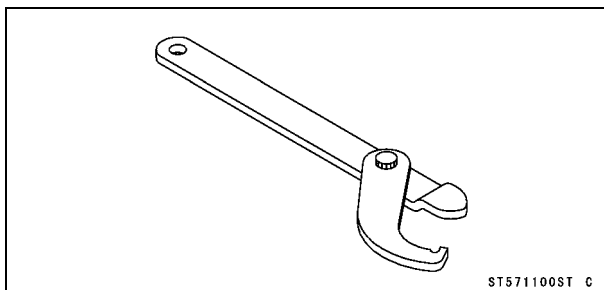

**Head Pipe Outer Race Driver, $\phi 55$:
57001-1446**

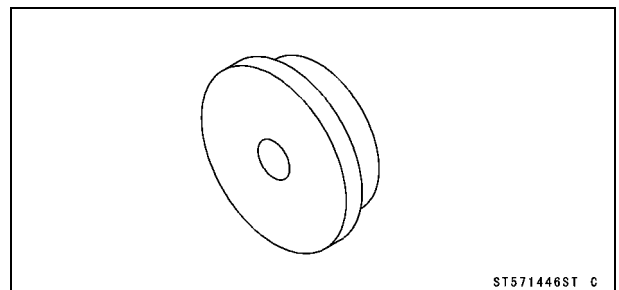

Steering

Steering Inspection

- Refer to the Steering Play Inspection in the Periodic Maintenance chapter (see Steering Play Inspection in the Periodic Maintenance chapter).

Steering Adjustment

- Refer to the Steering Play Adjustment in the Periodic Maintenance chapter (see Steering Play Adjustment in the Periodic Maintenance chapter).

www.zxforums.com

Steering Damper

Steering Damper Removal

- Remove the TORX bolt [A] and washer [B].
- Remove the bolt [C], washer, collar and steering damper [D].

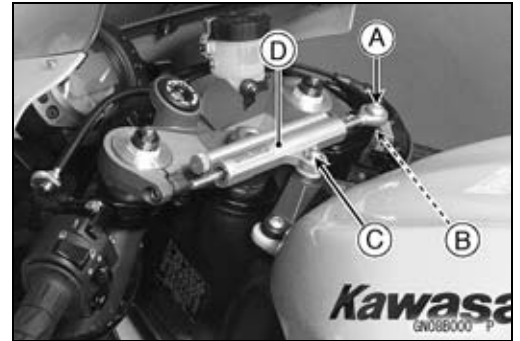

Steering Damper Installation

- Install the steering damper [F] and parts as shown.
 - Collar [A]
 - Washer [B]
 - Fuel Tank Bracket [C]
 - Bolt [D]
 - Washer [E]
- Tighten a new TORX bolt [G].

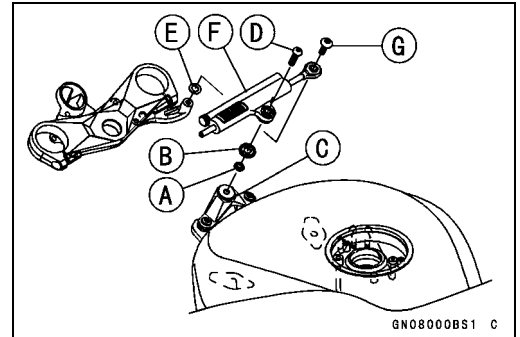

Damping Force Adjustment

- To adjust the damping force, turn the damping adjuster [B] clockwise or counterclockwise.
 - Steering Damper [A]
 - Softer (counterclockwise) [C]
 - Harder (clockwise) [D]
- The standard adjuster setting is the **18 turns out (fully counterclockwise position)** from the fully clockwise position.

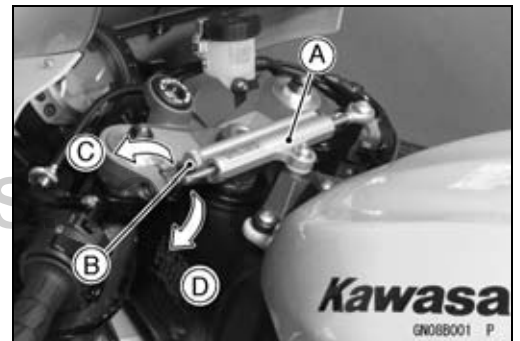

Damping Force Adjustment

Adjuster Position	Damping Force	Setting
18 turns out (fully counterclockwise position)	Weak	Soft
↑	↑	↑
↓	↓	↓
0	Strong	Hard

Steering Damper Oil Leak Inspection

- Refer to the Steering Damper Oil Leak Inspection in the Periodic Maintenance chapter (see Steering Damper Oil Leak Inspection in the Periodic Maintenance chapter).

Steering Stem

Stem, Stem Bearing Removal

- Remove:
 - Steering Damper (see Steering Damper Removal)
 - Steering Stem Head Nut [A] and Washer [B]
 - Steering Stem Head [C]
 - Handlebars [D]

 - Remove:
 - Brake Hose Clamp [A]
 - Right Switch Housing Lead Clamp [B]

 - Remove the left switch housing lead and ignition switch lead clamp [A].

 - Remove:
 - Front Wheel (see Front Wheel Removal in the Wheels/Tires chapter)
 - Front Forks (see Front Fork Removal in the Suspension chapter)

 - Bend the claws [A] of lock washer straighten.
 - Remove the steering stem locknut [B].
- Special Tool - Steering Stem Nut Wrench: 57001-1100**

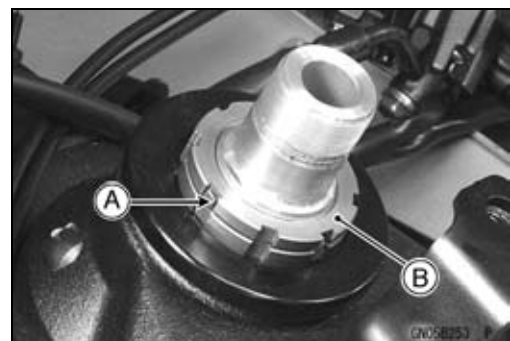
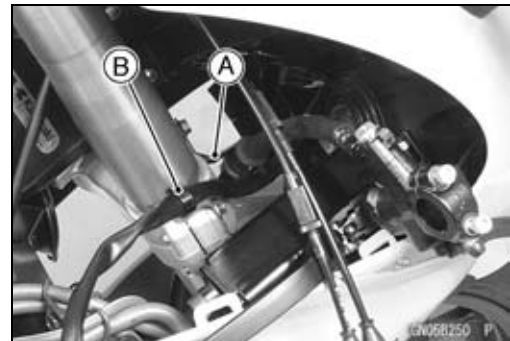
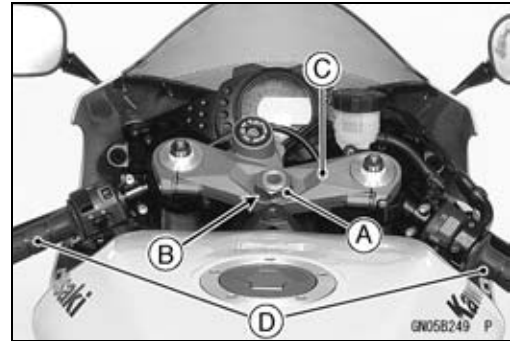

Steering Stem

- Remove the lock washer [A].



- Pushing up the stem base, and remove the steering stem nut with stem cap [A].
 - Remove:
 - Steering Stem [C]
 - Upper Ball Bearing Inner Race
- Special Tool - Steering Stem Nut Wrench [B]: 57001-1100**

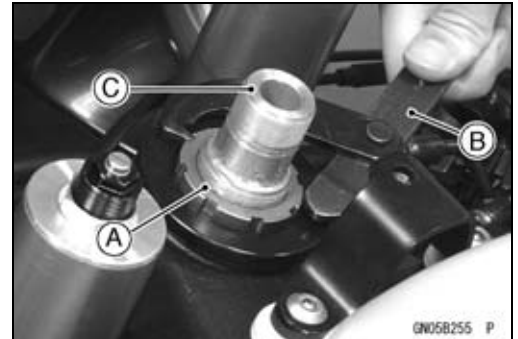

- To remove the bearing outer races [A] pressed into the head pipe [B], insert a bar [C] into the recesses [D] of head pipe, and applying it to both recess alternately hammer it to drive the race out.

NOTE

○ If either steering stem bearing is damaged, it is recommended that both the upper and lower bearings (including outer races) should be replaced with new ones.

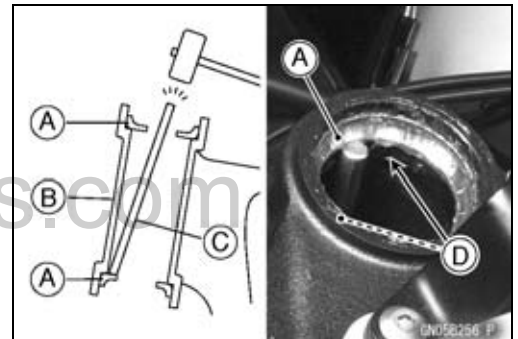

- Remove the lower bearing inner race (with its grease seal) [A] which is pressed onto the steering stem [B] with the bearing puller [C] and adapter [D].

Special Tools - Bearing Puller Adapter: 57001-136
Bearing Puller: 57001-158

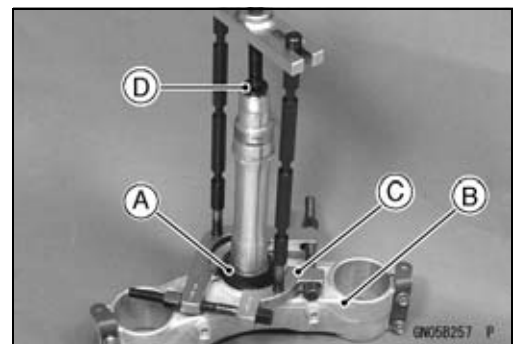

Stem, Stem Bearing Installation

- Replace the bearing outer races with new ones.
- Drive them into the head pipe at the same time.

Special Tools - Head Pipe Outer Race Press Shaft [A]: 57001-1075
Bearing Driver Set: 57001-1129
Head Pipe Outer Race Driver, $\phi 55$ [B]: 57001-1446

- Apply grease:
 - Outer Races

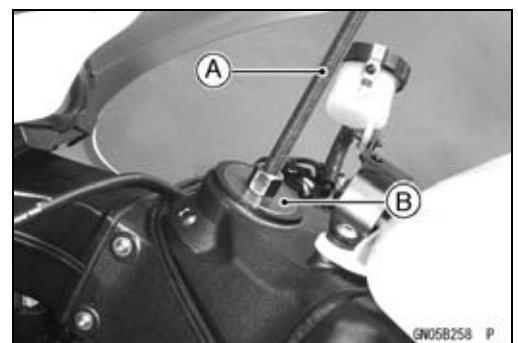

Steering Stem

- Replace the bearing inner races with new ones.
- Install the oil seal [D] on the steering stem, and drive the lower ball bearing inner race [A] applied the grease onto the stem.

Special Tools - Steering Stem Bearing Driver [B]: 57001-1344

Steering Stem Bearing Driver Adapter [C]: 57001-1345

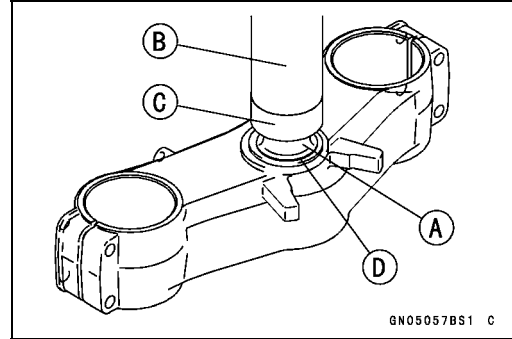

- Install the lower ball bearing [A] onto the stem.
- Apply grease:
 - Inner and Outer Races
 - Lower and Upper Ball Bearings
- The lower and upper ball bearings are identical.

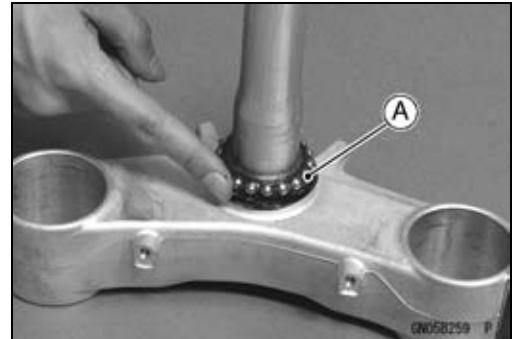

- Install the stem [A] through the head pipe and install the ball bearing [B] and inner race [C] on it.
- Install:
 - Stem Cap [D]
 - Steering Stem Nut [E]

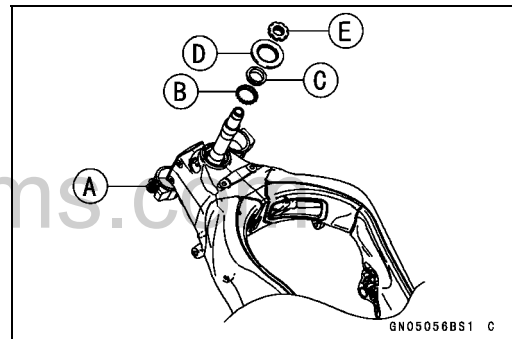

- Settle the bearings in place as follows:
 - Tighten the steering stem nut with **55 N·m (5.6 kgf·m, 41 ft·lb)** of torque first, and loosen it a fraction of a turn until it turns lightly. (To tighten the stem nut to the specified torque, hook the wrench on the stem nut, and pull the wrench at the hole by **305 N (31.0 kgf, 68.6 lb)** [B] force in the direction shown.) Afterward tighten it again with specified torque using a special tool [A].

Special Tool - Steering Stem Nut Wrench: 57001-1100

Torque - Steering Stem Nut: 20 N·m (2.0 kgf·m, 15 ft·lb)

- For the torque of 20 N·m (2.0 kgf·m, 15 ft·lb), pull the wrench at the hole by 101 N (11.1 kgf, 24.5 lb) force.

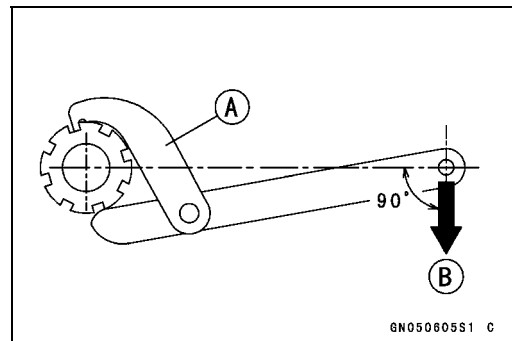

Steering Stem

- Install the lock washer [A] so that claw [B] of washer fit the notch [C] of steering stem locknut [D].

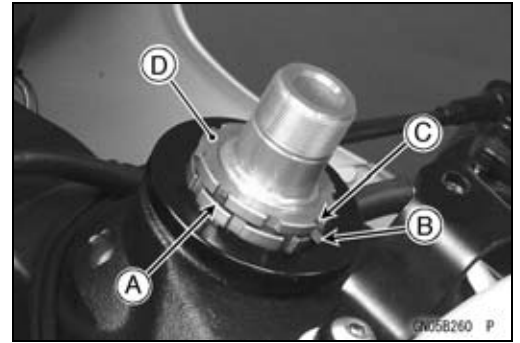

- First tighten the steering stem locknut by hand until the resistance is felt fully, then tighten the steering stem locknut so that align the claw [A] of stem locknut to the notch [B] of stem nut by hand.
- Check that there is no play and the steering stem turns smoothly without rattles. If not, the steering stem bearing may be damaged.
- Bend the claw of lock washer [C] to steering stem nut notch.

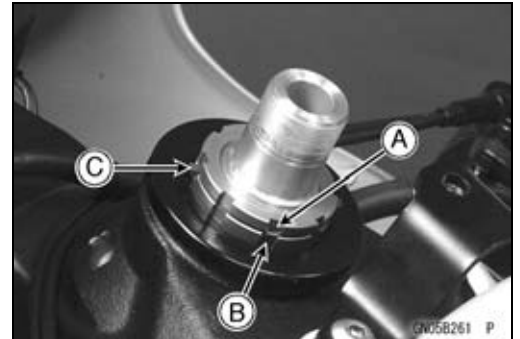

- Install the stem head [A] with handlebars to the steering stem [B].
- Install the washer, and temporary tighten the stem head nut [C].
- Install the front forks (see Front Fork Installation in the Suspension chapter).

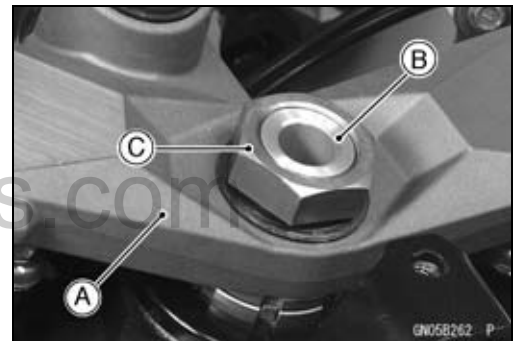

NOTE

- Tighten the fork upper clamp bolts [A] first, next the stem head nut [B], last the fork lower clamp bolts [C] and the handlebar bolts [D].
- Tighten the two lower fork clamp bolts alternately two times to ensure even tightening torque.

Torque - Front Fork Clamp Bolts (Upper): 20 N·m (2.0 kgf·m, 15 ft·lb)

Steering Stem Head Nut: 78 N·m (8.0 kgf·m, 58 ft·lb)

Front Fork Clamp Bolts (Lower): 30 N·m (3.1 kgf·m, 22 ft·lb)

Handlebar Bolts: 25 N·m (2.5 kgf·m, 18 ft·lb)

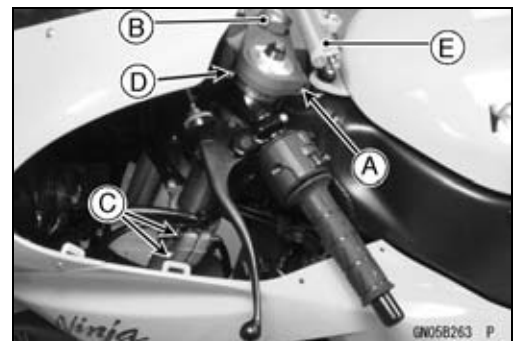

⚠ WARNING

Do not impede the handlebar turning by routing the cables, harnesses and hoses improperly (see Appendix chapter).

- Install the steering damper [E] (see Steering Damper Installation).

Steering Stem

Steering Stem Bearing Lubrication

- Refer to the Steering Stem Bearing Lubrication in the Periodic Maintenance chapter (see Steering Stem Bearing Lubrication in the Periodic Maintenance chapter).

Steering Stem Warp

- Whenever the steering stem is removed, or if the steering can not be adjusted for smooth action, check the steering stem for straightness.
- ★ If the steering stem [A] is bent, replace the steering stem.

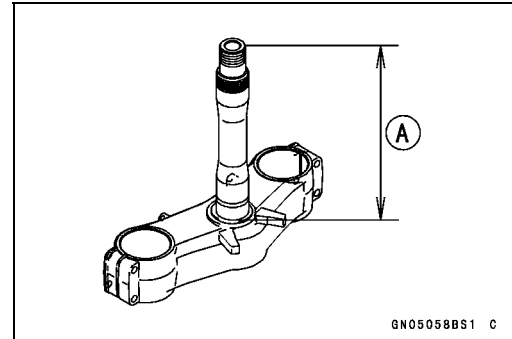

Stem Cap Deterioration, Damage

- ★ Replace the stem cap if its grease seal [A] shows damage.



www.zxforums.com

Handlebar

Handlebar Removal

- Remove:
 - Steering Damper (see Steering Damper Removal)
 - Clutch Lever Clamp Bolts [A]
 - Clutch Lever Assembly [B]
 - Left Switch Housing [C]
 - Handlebar Weight [D]

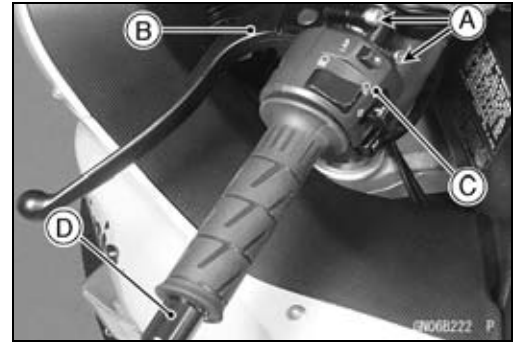

- Remove:
 - Front Brake Reservoir Bracket Nut [A]
 - Front Brake Master Cylinder [B]
 - Front Brake Light Switch Connector [C]
 - Right Switch Housing [D]
 - Throttle Case [E]
 - Throttle Grip [F]
 - Handlebar Weight [G]

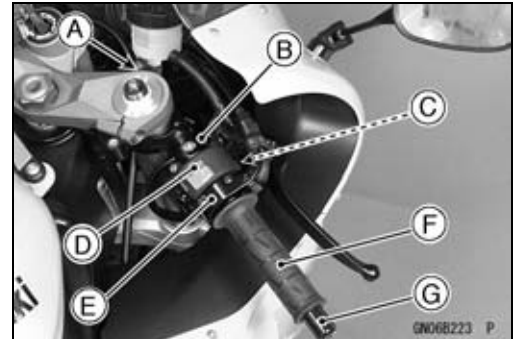

- Loosen:
 - Front Fork Clamp Bolts [A]
 - Handlebar Bolts [B]
- Remove:
 - Steering Stem Head Nut and Washer [C]
 - Steering Stem Head [D] with Handlebars [E]

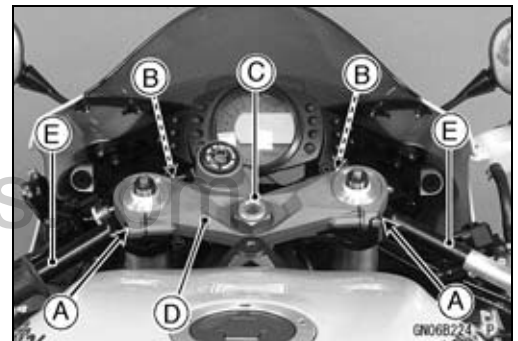

- Remove:
 - Handlebar Position Bolts [A]
 - Handlebars [B]
 - Left Handlebar Grip

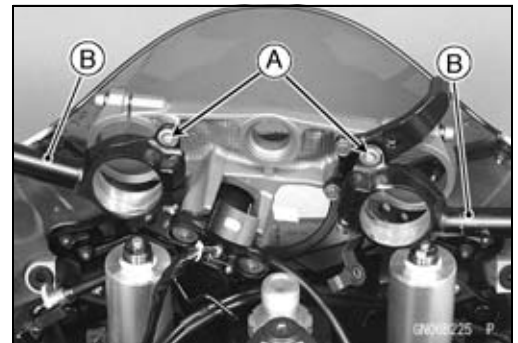

Handlebar Installation

- Apply adhesive cement to the inside of the left handlebar grip.
- Apply a non-permanent locking agent:
 - Handlebar Position Bolts

Torque - Handlebar Bolts: 25 N·m (2.5 kgf·m, 18 ft·lb)

Handlebar Position Bolts: 9.8 N·m (1.0 kgf·m, 87 in·lb)

- Install the front brake master cylinder (see Front Master Cylinder Installation in the Brakes chapter).

Handlebar

- Install the left and right switch housings.
- Fit the projection [A] into a small hole [B] in the handlebar.
 - Torque - Handlebar Switch Housing Screws: 3.5 N·m (0.36 kgf·m, 31 in·lb)**
- Connect the front brake light switch connector.

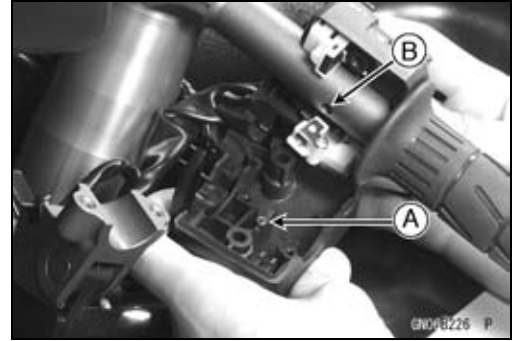

- Install the clutch lever [A] so that the mating surface [B] of the clutch lever clamps with punch mark [C] on the handlebar.

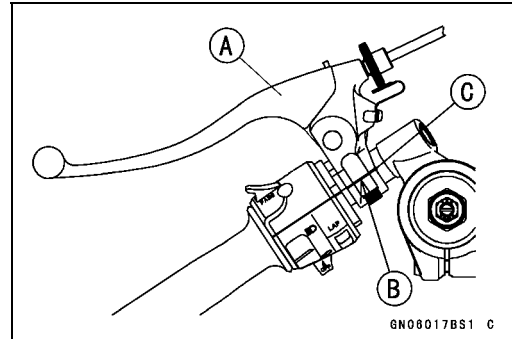

- Install:
 - Throttle Grip
 - Throttle Cable Tips [A]
 - Throttle Cases [B]
- Fit the projection [C] into a small hole [D] in the handlebar.

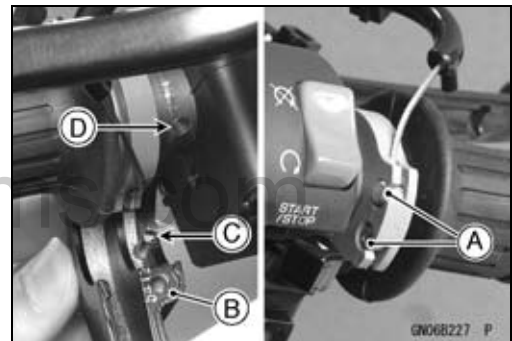

- Tighten:
 - Handlebar Weights
- Install the removed parts (see appropriate chapters).

Frame

Table of Contents

Exploded View	15-2
Seats	15-8
Rear Seat Removal.....	15-8
Rear Seat Installation.....	15-8
Front Seat Removal.....	15-8
Front Seat Installation	15-8
Fairings.....	15-9
Lower Fairing Removal.....	15-9
Lower Fairing Installation.....	15-9
Middle Fairing Removal	15-9
Middle Fairing Installation	15-10
Windshield Removal	15-10
Windshield Installation	15-11
Upper Fairing Removal.....	15-11
Upper Fairing Disassembly.....	15-11
Upper Fairing Assembly.....	15-11
Upper Fairing Installation	15-11
Upper Inner Fairing Removal.....	15-12
Upper Inner Fairing Installation.....	15-12
Center Inner Fairing Removal.....	15-12
Center Inner Fairing Installation.....	15-12
Right and Left Inner Fairing Removal	15-13
Right and Left Inner Fairing Installation	15-13
Side Covers.....	15-14
Side Cover Removal	15-14
Side Cover Installation	15-14
Seat Cover.....	15-15
Seat Cover Removal.....	15-15
Seat Cover Installation.....	15-16
Fenders	15-17
Front Fender Removal.....	15-17
Front Fender Installation	15-17
Rear Fender Rear Removal.....	15-17
Rear Fender Rear Installation.....	15-18
Rear Fender Front Removal	15-18
Rear Fender Front Installation	15-19
Frame	15-20
Rear Frame Removal.....	15-20
Rear Frame Installation.....	15-20
Frame Inspection	15-20
Sidestand.....	15-21
Sidestand Removal.....	15-21
Sidestand Installation.....	15-21

Exploded View

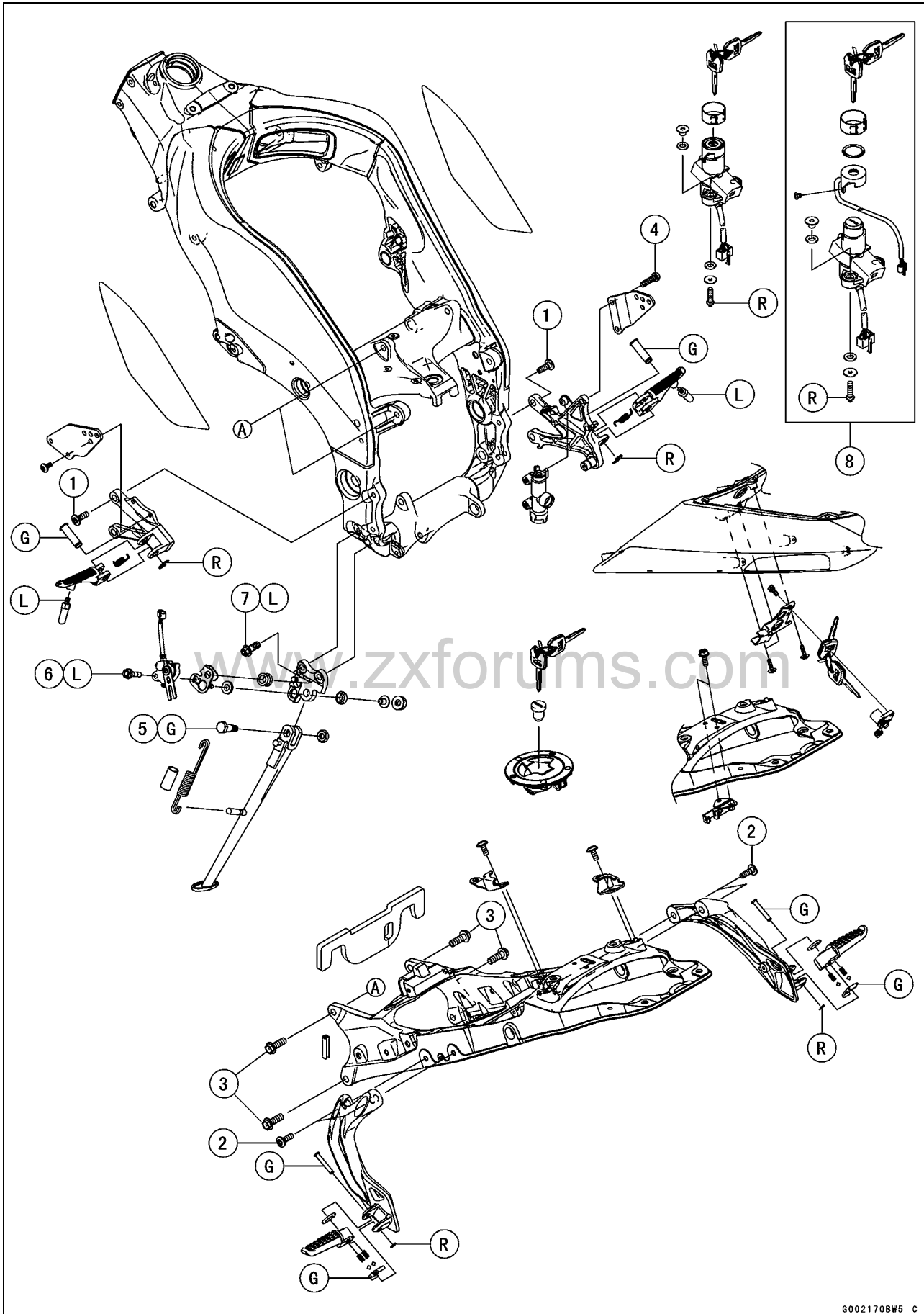

6002170BW5 C

Exploded View

No.	Fastener	Torque			Remarks
		N·m	kgf·m	ft·lb	
1	Front Footpeg Bracket Bolts	25	2.5	18	
2	Rear Footpeg Bracket Bolts	25	2.5	18	
3	Rear Frame Bolts	44	4.5	32	
4	Rear Master Cylinder Mounting Bolts	25	2.5	18	
5	Sidestand Bolt	44	4.5	32	G
6	Sidestand Switch Bolt	8.8	0.90	78 in·lb	L
7	Sidestand Bracket Bolts	49	5.0	36	L

8. Immobilizer Models

G: Apply grease.

L: Apply a non-permanent locking agent.

R: Replacement Parts

www.zxforums.com

Exploded View

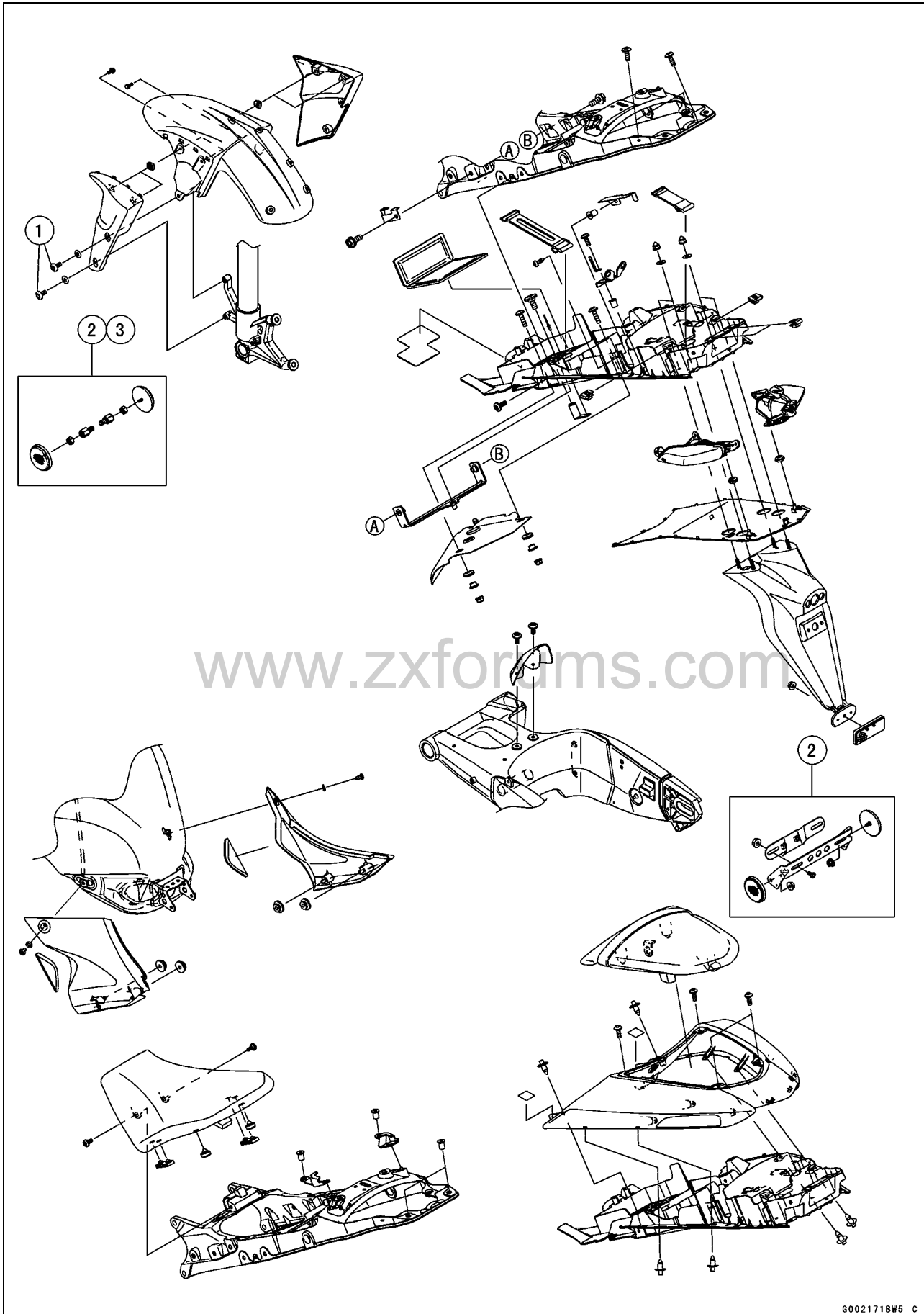

6002171BW5 C

Exploded View

No.	Fastener	Torque			Remarks
		N·m	kgf·m	ft·lb	
1	Front Fender Mounting Bolts	3.9	0.40	35 in·lb	

2. United States and Canada Models
3. Australian Models

www.zxforums.com

Exploded View

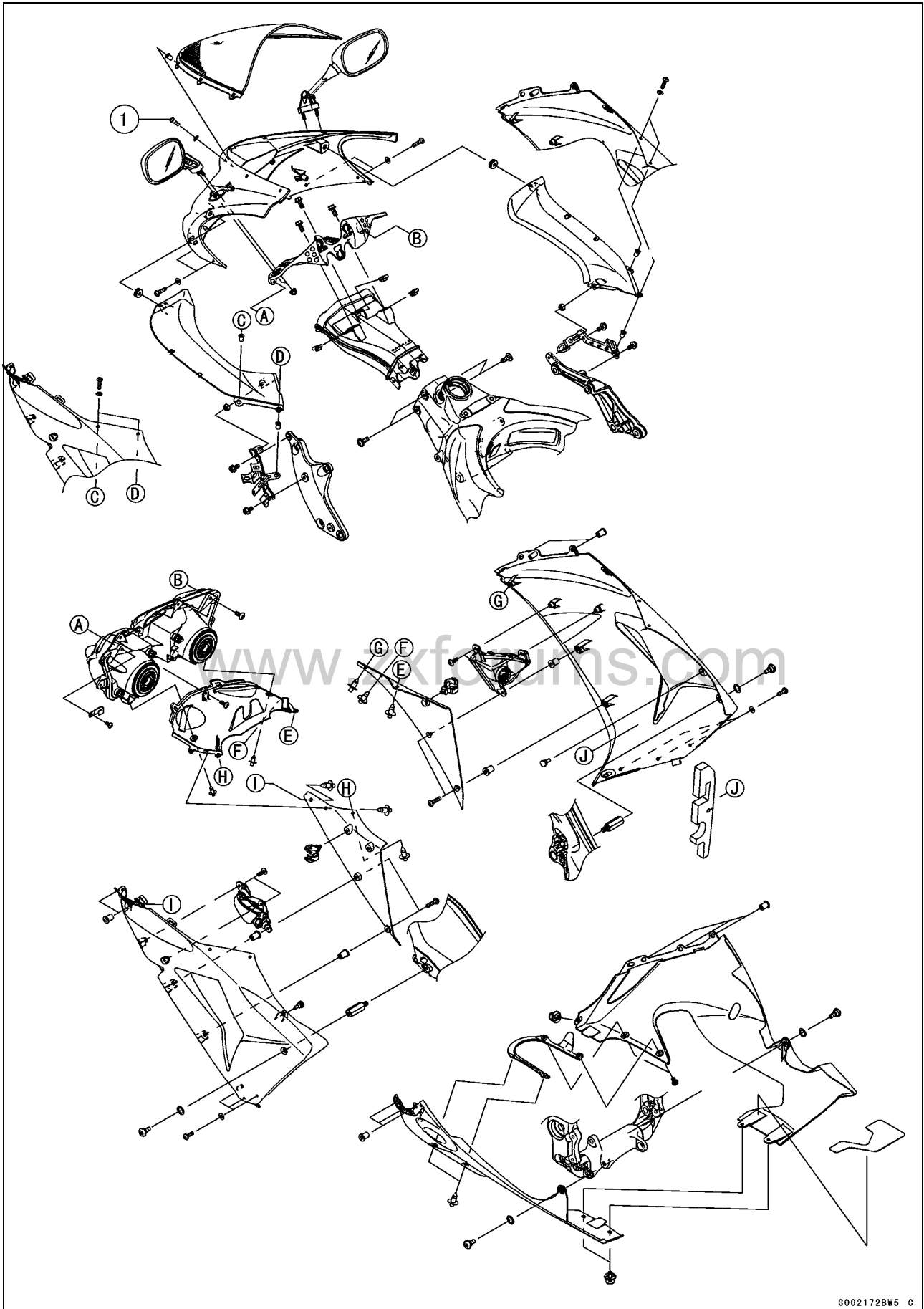

Exploded View

No.	Fastener	Torque			Remarks
		N·m	kgf·m	ft·lb	
1	Windshield Mounting Bolts	0.4	0.04	4 in·lb	

www.zxforums.com

Seats

Rear Seat Removal

- Insert the ignition switch key [A] into the seat lock, turning the key counterclockwise, pulling the front part of the seat [B] up, and pull the seat forward.

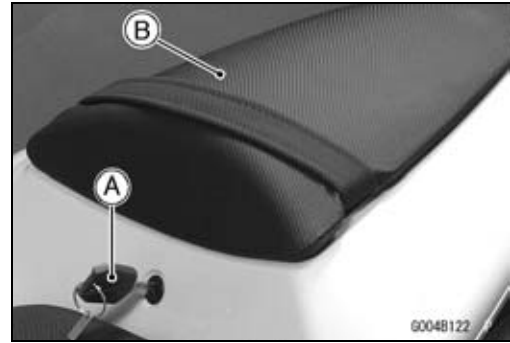

Rear Seat Installation

- Put the rear seat hook [A] on the rib [B].
- Insert the seat pin [C] into the latch hole [D].

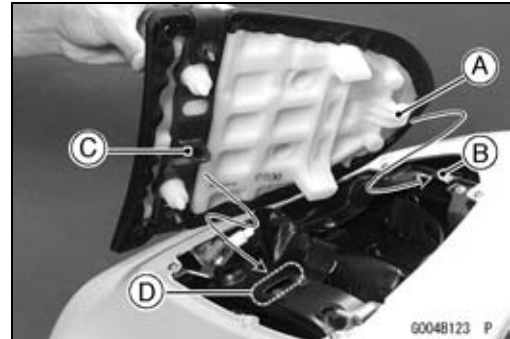

Front Seat Removal

- Remove:
 - Side Covers (Left and Right) (see Side Cover Removal)
 - Mounting Bolts [A] (Left and Right)
- Remove the front seat by pulling the front of it up and forward.



Front Seat Installation

- Slip the front seat hook [A] under the rib [B].
- Tighten the mounting bolts.
- Install the side covers.

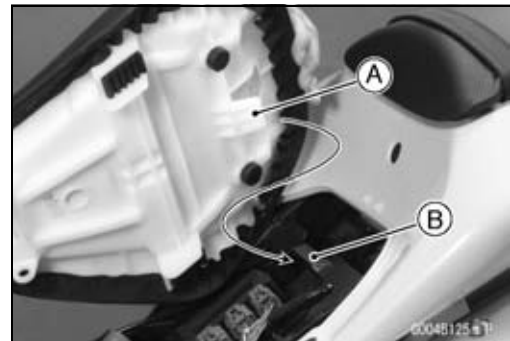

Fairings

Lower Fairing Removal

- Pull up the core [A] by the thin blade driver [B].

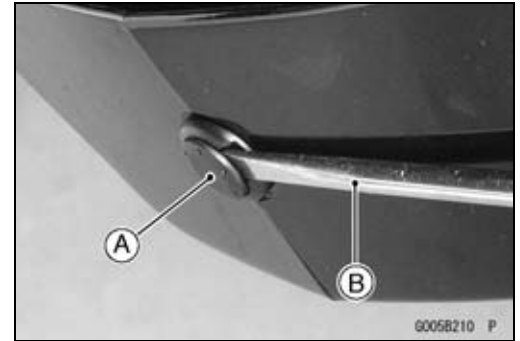

- Remove:
 - Quick Rivets [A]
 - Bolts [B] with Washers
 - Screws [C]
- Separate the right lower fairing [D] from the left lower fairing.
- Clear the hook portion and projection [E] from the slots.
- Remove the right lower fairing.

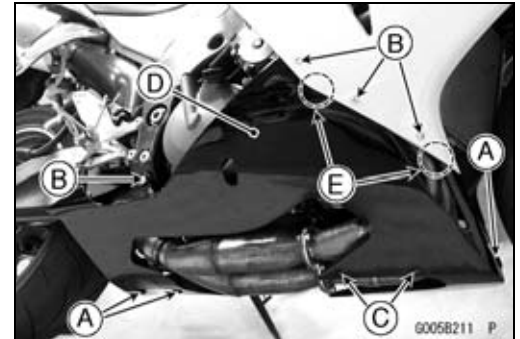

Lower Fairing Installation

- Insert the hook portion [A] into the slot [B], and put the projection [C] into the hole [D].
- Tighten the bolts with washers.

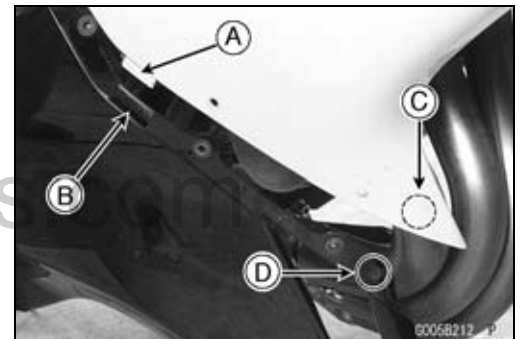

- Set the quick rivet [A] and push the core [B].

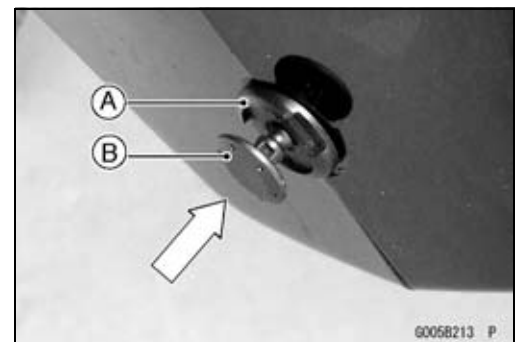

Middle Fairing Removal

- Remove:
 - Lower Fairings (see Lower Fairing Removal)
 - Upper Inner fairings (see Upper Inner Fairing Removal)
 - Bolts [A] with Washers
 - Quick Rivets [B]
- Disconnect the right turn signal lead connector.
- Clear the hook portions [D] from the slots by pulling the middle fairing backward.
- Remove the right middle fairing [C].

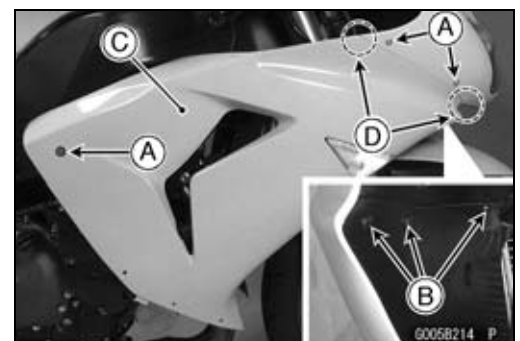

Fairings

For the California Model

○ Remove:

Band [A]

Canister [B]

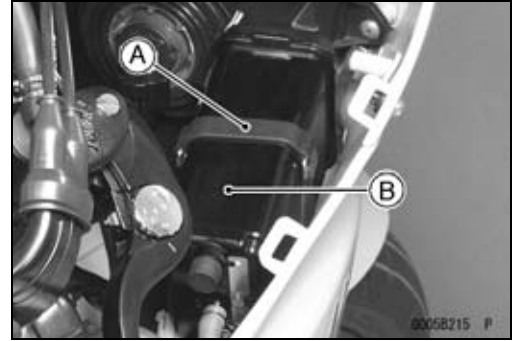

○ Clear the right switch housing lead from the clamp [A].

○ Disconnect the right turn signal lead connector [B].

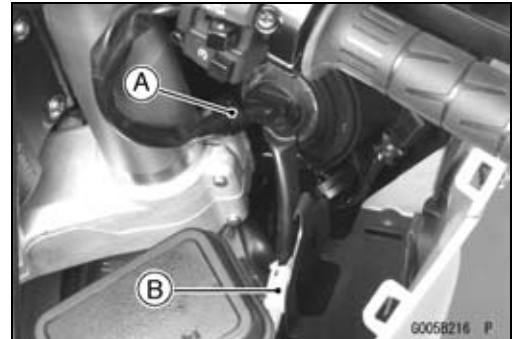

- Disconnect the left turn signal lead connector [A].
- Clear the left switch housing lead and ignition switch lead from the clamp [B].

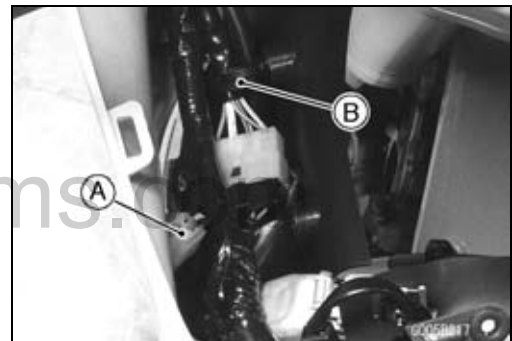

Middle Fairing Installation

- Connect the turn signal lead connectors.
- Clamp the left and right switch leads and ignition switch lead (California Model).
- Install the canister with the band (California Model).
- Insert the hooks [A] into the slots [B], and install the middle fairing [C].
- Install the upper inner fairings (see Upper Inner Fairing Installation).
- Install the washers and bolts.
- Install the quick rivets.

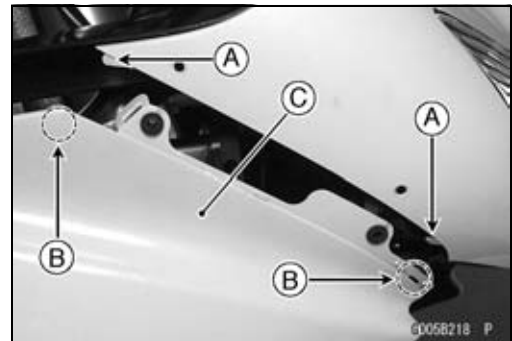

Windshield Removal

● Remove:

Bolts [A] and Washers

Windshield [B]

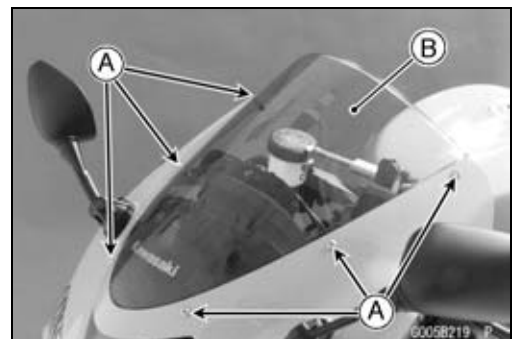

Fairings

Windshield Installation

- Put the front tongue [A] into the hollow [B].
- Torque - Windshield Mounting Bolts: 0.4 N·m (0.04 kgf·m, 4 in·lb)**

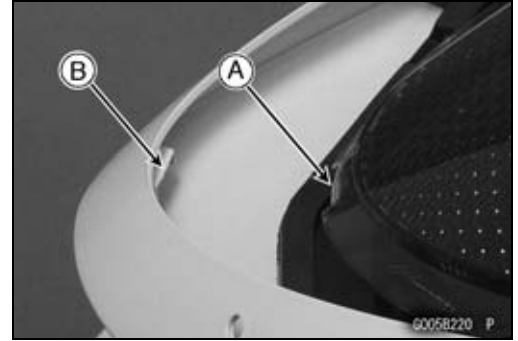

Upper Fairing Removal

- Remove:
 - Lower Fairings (see Lower Fairing Removal)
 - Upper Inner Fairings (see Upper Inner Fairing Removal)
 - Windshield (see Windshield Removal)
 - Middle Fairings (see Middle Fairing Removal)
 - Bolts [A]
 - Meter Lead Connector [B]

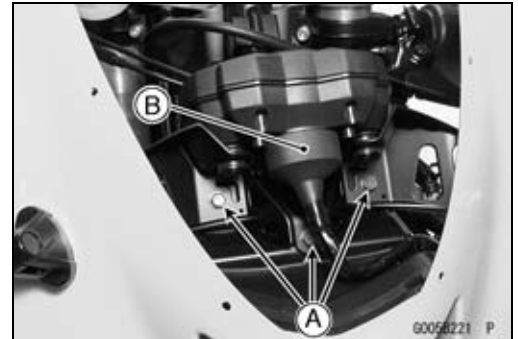

- Disconnect the headlight lead connectors [A] and city light lead connectors [B] (Left and Right).
- Remove the upper fairing.
- Pull out the upper fairing forward.

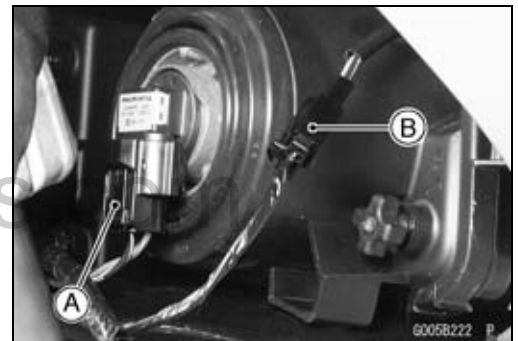

Upper Fairing Disassembly

- Remove:
 - Center Inner Fairing (see Center Inner Fairing Removal)
 - Nuts [A]
 - Screws [B]
 - Clamp [D]
 - Rear View Mirrors (Left and Right)
 - Meter Unit [C] with bracket (see Meter Unit Removal in the Electrical System chapter)
 - Headlight (see Headlight Removal in the Electrical System chapter)

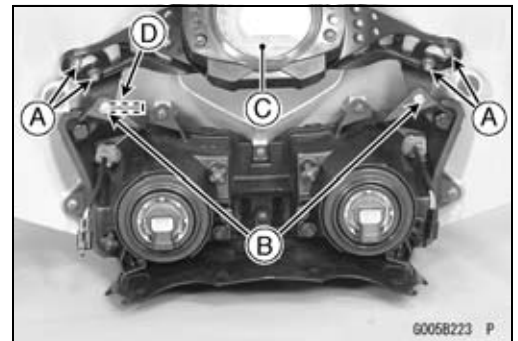

Upper Fairing Assembly

- Install the removed parts (see appropriate chapters).

Upper Fairing Installation

- Install the removed parts (see appropriate chapters).

Fairings

Upper Inner Fairing Removal

- Remove the bolts [A] with washers.
- Remove the upper inner fairing [B].
- Remove the upper inner fairing by pulling the rear of it up and upward to clear the projection from the stopper [C].
- Remove the upper inner fairing by sliding the front of it up and backward to clear the projection from the stopper [D].

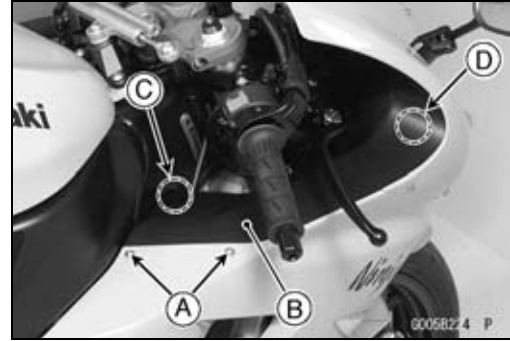

Upper Inner Fairing Installation

- Fit the projections [B] of the upper inner fairing [C] into the holes [A] of the upper fairing.
- Tighten the bolts.

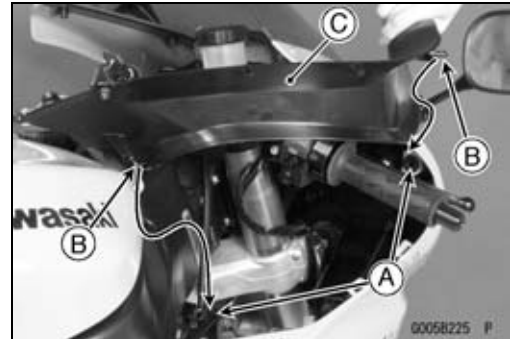

Center Inner Fairing Removal

- Remove:
 - Upper Fairing (see Upper Fairing Removal)
 - Screw [A]



- Remove:
 - Quick Rivets [A]
 - Center Inner Fairing [B]
- Slide out the center inner fairing backward.

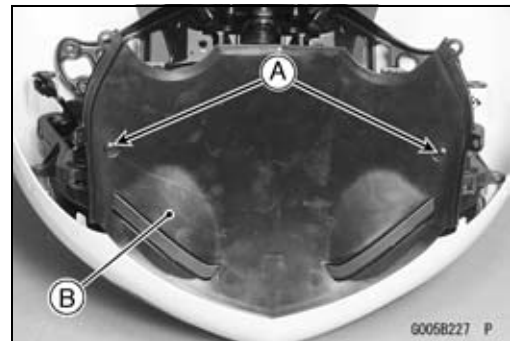

Center Inner Fairing Installation

- Insert the tongues [C] of the upper fairing into the holes [A] of the center inner fairing [B].

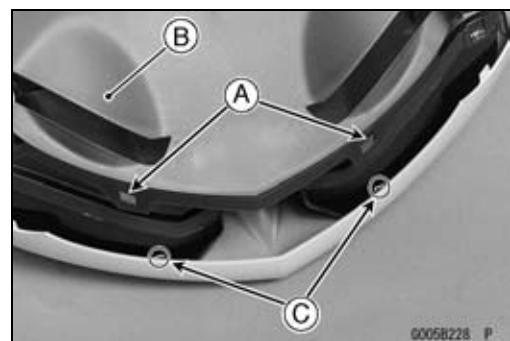

Fairings

Right and Left Inner Fairing Removal

- Remove:
 - Right and Left Middle Fairings (see Middle Fairing Removal)
 - Bolts [A]
 - Inner Fairing [B]

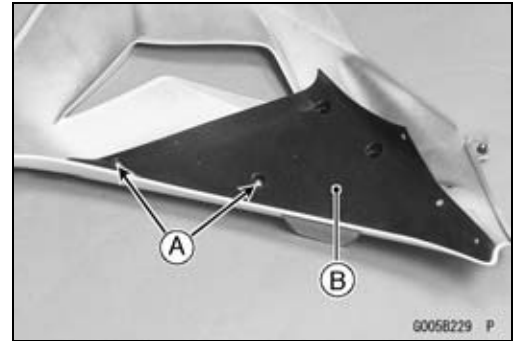

Right and Left Inner Fairing Installation

- Tighten the bolts [A].

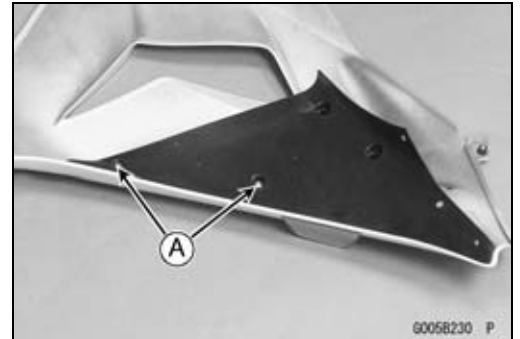

Side Covers

Side Cover Removal

- Remove:
Bolt and Washer [A]
- Pull out the side cover [B].

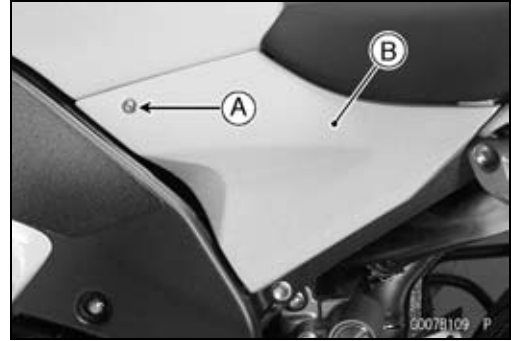

Side Cover Installation

- Insert the projections [A] into the holes [B].
- Tighten the bolt with washer.

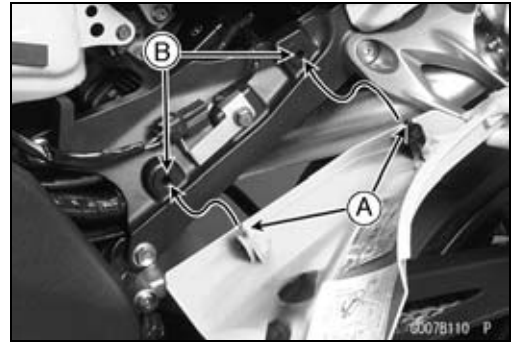

Seat Cover

Seat Cover Removal

- Remove:
 - Seats (see Seats section)
 - Bolts [A]
 - Quick Rivets [B]
- Pull the seat cover backward, and clear the projections from the holes.

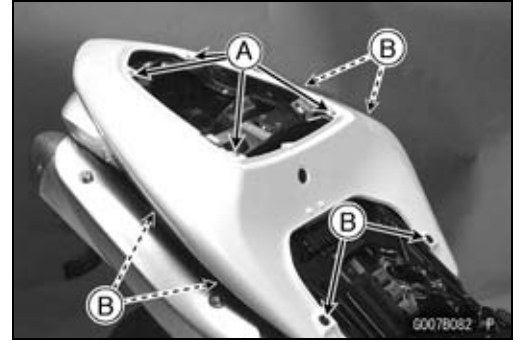

- Disconnect:
 - Tail/Brake Light Lead Connector [A]
 - Turn Signal Light Lead Connectors [B]

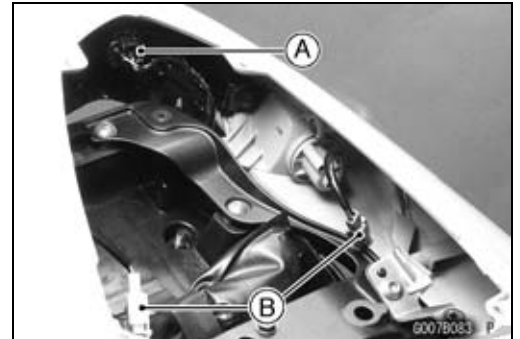

- Remove:
 - Seat Lock Cable [A]
- Pull the seat cover backward.



- Remove:
 - Screws and Collars [A]
 - Tail/Brake Light [B]

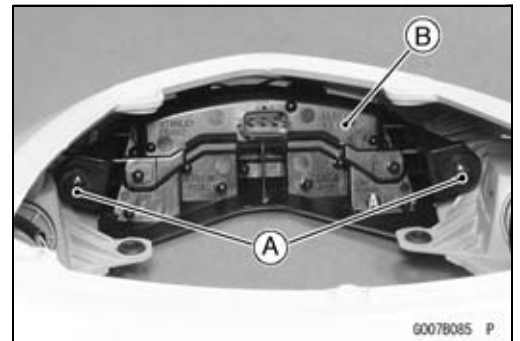

- Remove:
 - Screws [A]
 - Turn Signal Lights [B] (Left and Right)

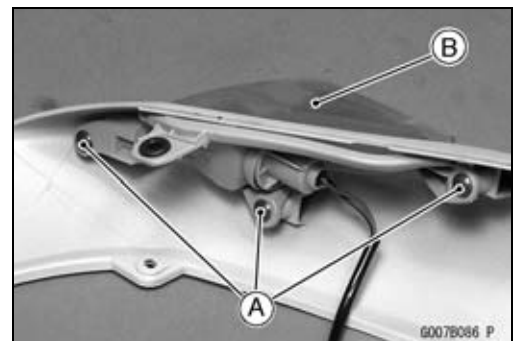

Seat Cover

- Remove:
Screws [A]
Seat Lock Assy [B]

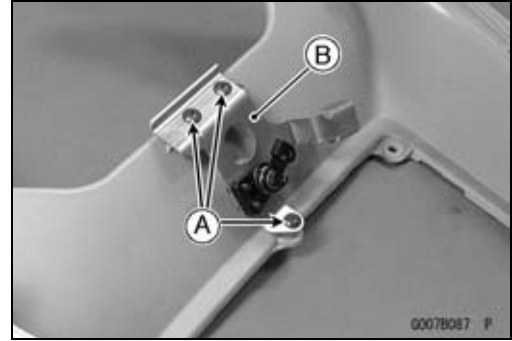

Seat Cover Installation

- Install the seat lock assy with screws.
- Connect the tail/brake light lead connector.
- Install the tail/brake light [A] inserting the hooks [B] into the stoppers [C].
- Connect the both turn signal light lead connectors.

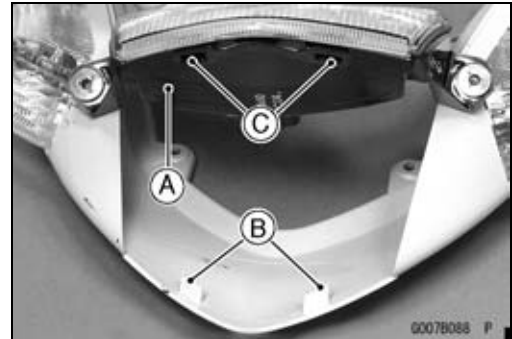

- Install the seat cover.
- Insert the projections [A] into the holes [B].
- Install:
Bolts
Quick Rivets

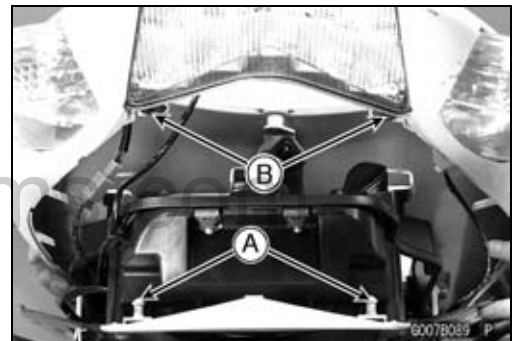

Fenders

Front Fender Removal

- Remove:
 - Brake Hose Clamps [A] (Left and Right)
 - Bolts [B] with Washers (Left and Right)
- Remove the front fender assy [C].

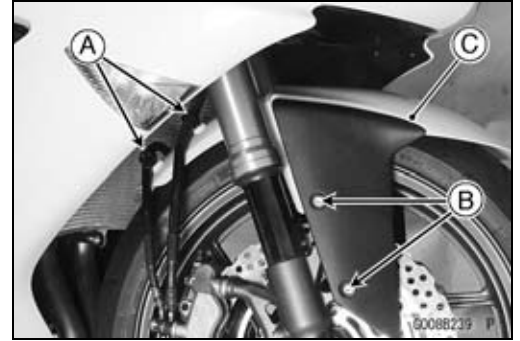

- Remove:
 - Bolts [A]
- Separate the front fender cover [B] and front fender [C].

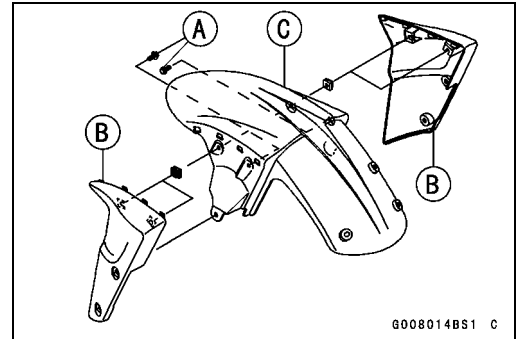

Front Fender Installation

- Install the front fender assy to the front fork.
- Tighten:
 - Torque - Front Fender Mounting Bolts: 3.9 N·m (0.40 kgf·m, 35 in·lb)
- Install the brake hose clamps to the front fender holes.

Rear Fender Rear Removal

- Remove the seat cover (see Seat Cove Removal).
- Disconnect the license light lead connector [A].



- Remove the nuts [A] with washers.



Fenders

- Pull out the rear fender rear [A] assembled turn signal lights and license plate light downward.



Rear Fender Rear Installation

- Install the harness clamp in accordance with Harness Routing section in Appendix chapter.

Rear Fender Front Removal

- Remove:
 - Seat Cover (see Seat Cover Removal in the chapter)
 - Middle Exhaust Pipe (see Middle and Rear Exhaust Pipe Removal in the Engine Top End chapter)
 - Rear Fender (see Rear Fender Rear Removal)
 - Battery [A] (see Battery Removal in the Electrical System chapter)
- Remove the fuse box [B] from the rear fender front.
- Remove:
 - Starter Relay [C] (see Starter Relay Inspection in the Electrical System chapter)
 - Relay Box [D] (see Relay Box Removal in the Electrical System chapter)
 - Turn Signal Relay [E] (see Turn Signal Relay Inspection in the Electrical System chapter)
 - ECU (see ECU Removal in the Fuel System (DFI) chapter)
 - Fuel Pump Connector [F] (see Fuel Tank Removal in the Fuel System (DFI) chapter) and Bracket
 - Exhaust Butterfly Valve Actuator [G] (see Exhaust Butterfly Valve Actuator Removal in the Fuel System (DFI) chapter)
 - Owner's Tool [H]
 - Atmospheric Pressure Sensor [I] (see Atmospheric Pressure Sensor section in the Fuel System (DFI) chapter)
 - Vehicle-down Sensor [J] (see Vehicle-down Sensor Removal in the Fuel System (DFI) chapter)
 - Bolts [K]

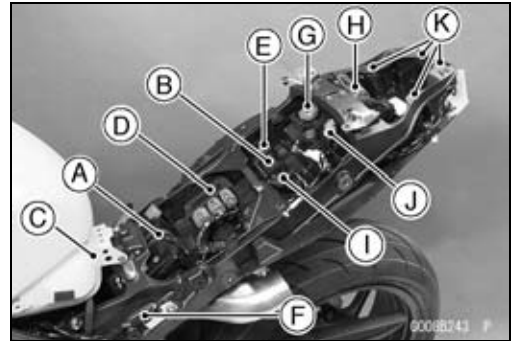

Fenders

- Remove:
 - Bolts and Nuts [A]
 - Collars [B]
 - Dampers [C]
 - Upper Heat Guard [D]
- Remove:
 - Bolt [E]
 - Bolts [F]
 - Fender Bracket [G]
- Remove:
 - Rivet [H]
 - Nut [I]
 - Bolt [J]
 - Rear Fender Front [K]
 - Front [L]
 - Viewed from Upside [M]

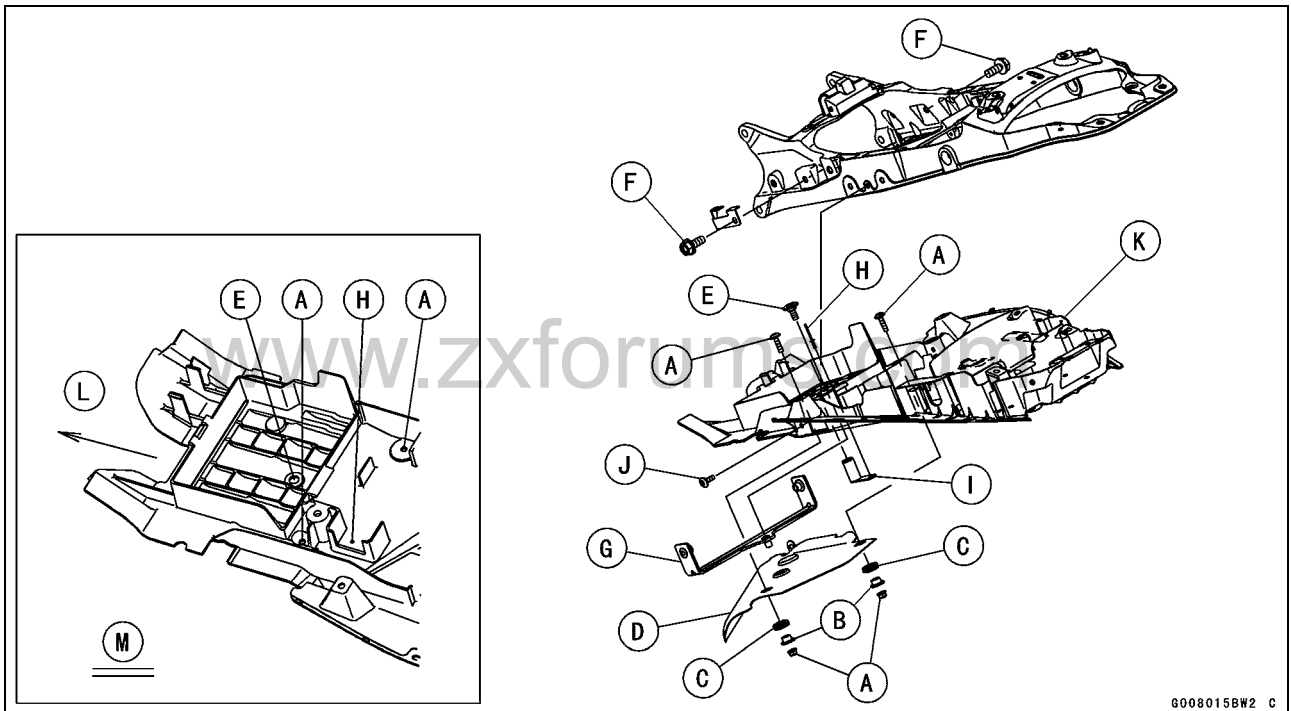

G0080156W2 C

Rear Fender Front Installation

- Insert the on the chassis.
- Install the removed parts (see appropriate chapters).
- Run the harness correctly (see Cable, Wire, and Hose Routing section in the Appendix chapter).

Frame

Rear Frame Removal

- Remove:
 - Vehicle-down Sensor (see Vehicle-down Sensor Removal in the Fuel System (DFI) chapter)
 - Seat Cover (see Seat Cover Removal)
 - Rear Fender Front (see Rear Fender Front Removal)
 - Clamps for Main Harness
 - Frame Bolts [A]



Rear Frame Installation

- Tighten:
 - Torque - Rear Frame Bolts: 44 N·m (4.5 kgf·m, 32 ft·lb)

Frame Inspection

- Visually inspect the frame for cracks, dents, bending, or warp.
- ★ If there is any damage to the frame, replace it.

WARNING

A repaired frame may fail in use, possibly causing an accident. If the frame is bent, dented, cracked, or warped, replace it.

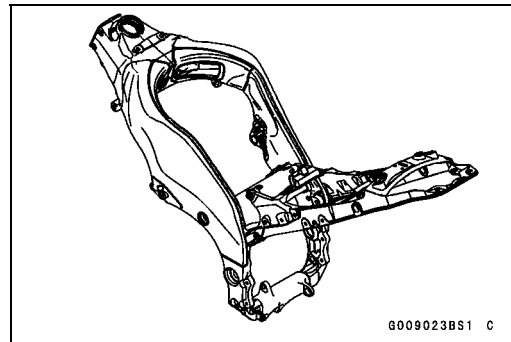

Sidestand

Sidestand Removal

- Raise the rear wheel off the ground with the stand.
- Remove:
 - Lower Fairings (see Lower Fairing Removal)
- Disconnect the sidestand switch lead connector [A] and clear the lead from the clamps [B].

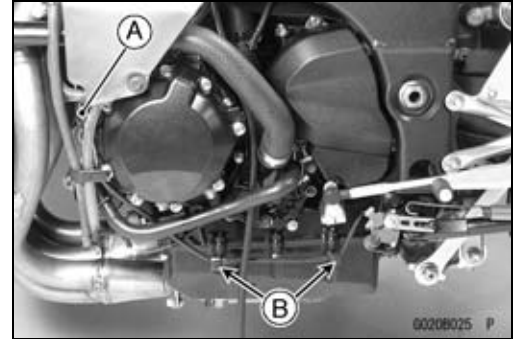

- Remove:
 - Sidestand Switch Bolt [A]
 - Spring [B]
 - Sidestand Bolt [C]
 - Sidestand [D]
 - Switch Bracket Bolt [E]
 - Sidestand Bracket Bolts [F]

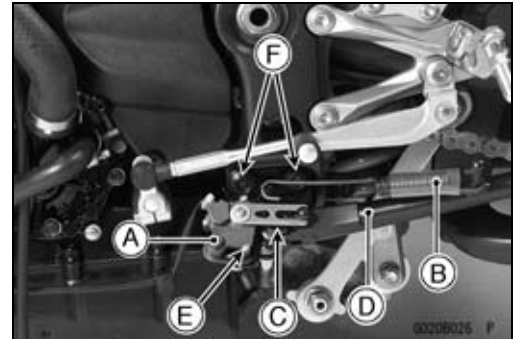

Sidestand Installation

- Apply grease to the sliding area [A] of the sidestand [B] and thread of the sidestand bolt [C].
- Apply a non-permanent locking agent to the threads of sidestand bracket bolts.
- Tighten the bolt and lock them with the nut.

Torque - Sidestand Bracket Bolts [D]: 49 N·m (5.0 kgf·m, 36 ft·lb)

Sidestand Bolt: 44 N·m (4.5 kgf·m, 32 ft·lb)

- Hook the spring [E] so that face the long spring end upward.
 - Install the spring hook direction as shown.
- Install the switch bracket and sidestand switch.
 - Apply a non-permanent locking agent to the thread of the switch bolt.

Torque - Sidestand Switch Bolt [F]: 8.8 N·m (0.90 kgf·m, 78 in·lb)

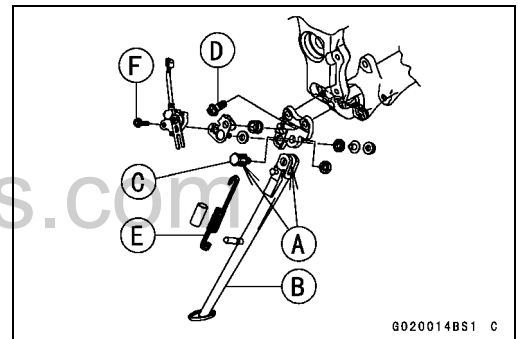

www.zxforums.com

Electrical System

Table of Contents

Exploded View.....	16-4
Parts Location.....	16-10
Wiring Diagram (United States, Canada, New Zealand, Colombia and Taiwan).....	16-11
Wiring Diagram (Other than United States, Canada, New Zealand, Colombia, Taiwan, Australia and Malaysia)	16-14
Wiring Diagram (Australia)	16-16
Wiring Diagram (Malaysia)	16-18
Specifications	16-20
Special Tools and Sealant	16-21
Precautions.....	16-22
Electrical Wiring.....	16-24
Wiring Inspection	16-24
Battery	16-25
Battery Removal	16-25
Battery Installation	16-25
Battery Activation.....	16-26
Precautions.....	16-28
Interchange.....	16-29
Charging Condition Inspection.....	16-29
Refreshing Charge.....	16-29
Charging System.....	16-31
Alternator Cover Removal.....	16-31
Alternator Cover Installation.....	16-31
Stator Coil Removal	16-31
Stator Coil Installation	16-32
Alternator Rotor Removal	16-32
Alternator Rotor Installation	16-32
Alternator Inspection	16-33
Regulator/Rectifier Inspection.....	16-35
Charging Voltage Inspection	16-36
Ignition System.....	16-38
Crankshaft Sensor Removal	16-39
Crankshaft Sensor Installation	16-39
Crankshaft Sensor Inspection.....	16-40
Crankshaft Sensor Peak Voltage Inspection.....	16-40
Stick Coil (Ignition Coil together with Spark Plug Cap) Removal.....	16-40
Stick Coil (Ignition Coil together with Spark Plug Cap) Installation.....	16-42
Stick Coil (Ignition Coil together with Spark Plug Cap) Inspection.....	16-43
Stick Coil Primary Peak Voltage	16-43
Spark Plug Removal	16-44
Spark Plug Installation	16-44
Spark Plug Condition Inspection.....	16-44
Camshaft Position Sensor Removal	16-45
Camshaft Position Sensor Installation	16-45
Camshaft Position Sensor Inspection.....	16-45
Camshaft Position Sensor Peak Voltage Inspection.....	16-46
Interlock Operation Inspection	16-46
IC Igniter Inspection	16-47
Electric Starter System.....	16-49
Starter Idle Gear Removal	16-49

Starter Idle Gear Installation	16-49
Starter Clutch Removal.....	16-51
Starter Clutch Installation	16-51
Starter Clutch Disassembly.....	16-52
Starter Clutch Assembly	16-52
Starter Clutch Inspection.....	16-52
Starter Motor Removal.....	16-53
Starter Motor Installation.....	16-54
Starter Motor Disassembly.....	16-54
Starter Motor Assembly	16-55
Brush Inspection	16-57
Commutator Cleaning and Inspection.....	16-57
Armature Inspection.....	16-57
Brush Lead Inspection	16-58
Right-hand End Cover Assembly Inspection	16-58
Starter Relay Inspection.....	16-58
Lighting System.....	16-60
Headlight Beam Horizontal Vertical Adjustment	16-60
Headlight Beam Vertical Adjustment.....	16-60
Headlight Bulb Replacement	16-60
City Light Bulb Replacement.....	16-61
Headlight Removal/Installation	16-61
Tail/Brake Light (LED) Removal.....	16-62
Tail/Brake Light (LED) Installation.....	16-62
License Plate Light Bulb Replacement	16-62
Turn Signal Light Bulb Replacement	16-63
Turn Signal Relay Inspection	16-65
Air Switching Valve	16-67
Air Switching Valve Operation Test.....	16-67
Air Switching Valve Unit Test	16-67
Radiator Fan System.....	16-68
Fan Motor Inspection	16-68
Meter, Gauge, Indicator Unit.....	16-69
Meter Unit Removal/Installation.....	16-69
Meter Unit Disassembly	16-69
Electronic Combination Meter Unit Inspection.....	16-70
Immobilizer System (Equipped Models).....	16-80
Operational Cautions	16-80
Key Registration.....	16-80
Immobilizer System Parts Replacement.....	16-96
Immobilizer System Inspection	16-98
Switches and Sensors	16-100
Brake Light Timing Inspection.....	16-100
Brake Light Timing Adjustment.....	16-100
Switch Inspection	16-100
Water Temperature Sensor Inspection	16-101
Speed Sensor Removal	16-101
Speed Sensor Installation	16-102
Speed Sensor Inspection.....	16-102
Fuel Reserve Switch Inspection.....	16-102
Oxygen Sensor Removal (Europe Models)	16-103
Oxygen Sensor Installation (Europe Models)	16-104
Oxygen Sensor Inspection (Europe Models).....	16-104
Oxygen Sensor Heater Inspection (Europe Models)	16-104
Gear Position Switch Removal	16-104
Gear Position Switch Installation	16-105
Gear Position Switch Inspection	16-106

Relay Box	16-107
Relay Box Removal	16-107
Relay Circuit Inspection	16-107
Diode Circuit Inspection	16-108
Fuse.....	16-110
30 A Main Fuse Removal.....	16-110
Fuse Box Fuse Removal.....	16-110
15 A ECU Fuse Removal.....	16-110
Fuse Installation.....	16-111
Fuse Inspection.....	16-111

www.zxforums.com

Exploded View

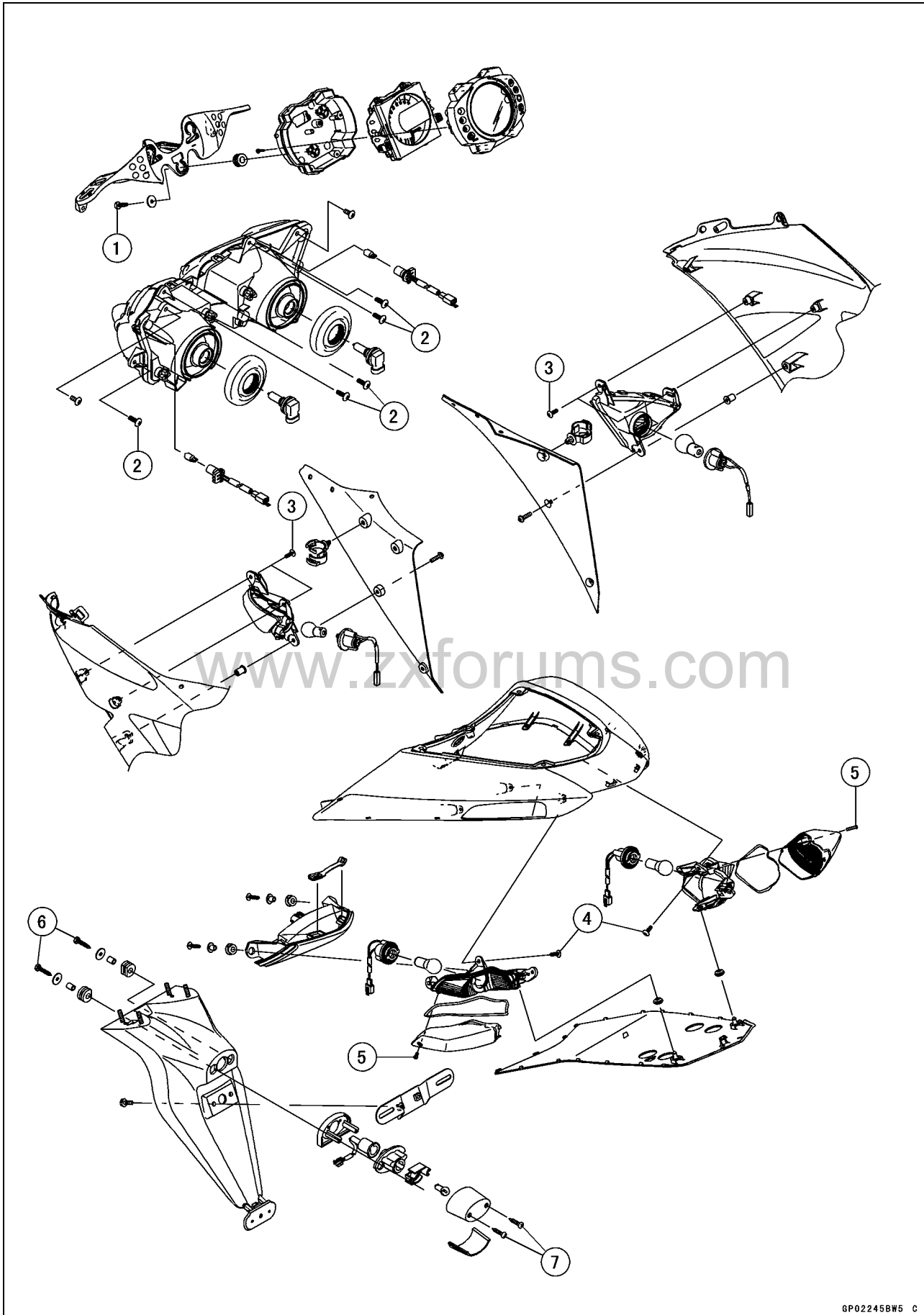

GP02245BW5 C

Exploded View

No.	Fastener	Torque			Remarks
		N·m	kgf·m	ft·lb	
1	Meter Unit Mounting Screws	1.2	0.12	11 in·lb	
2	Headlight Mounting Screws	1.2	0.12	11 in·lb	
3	Front Turn Signal Light Mounting Screws	1.2	0.12	11 in·lb	
4	Rear Turn Signal Light Mounting Screws	1.2	0.12	11 in·lb	
5	Rear Turn Signal Light Lens Screws	1.2	0.12	11 in·lb	
6	License Plate Light Mounting Screws	1.2	0.12	11 in·lb	
7	License Plate Light Cover Screws	1.2	0.12	11 in·lb	

www.zxforums.com

Exploded View

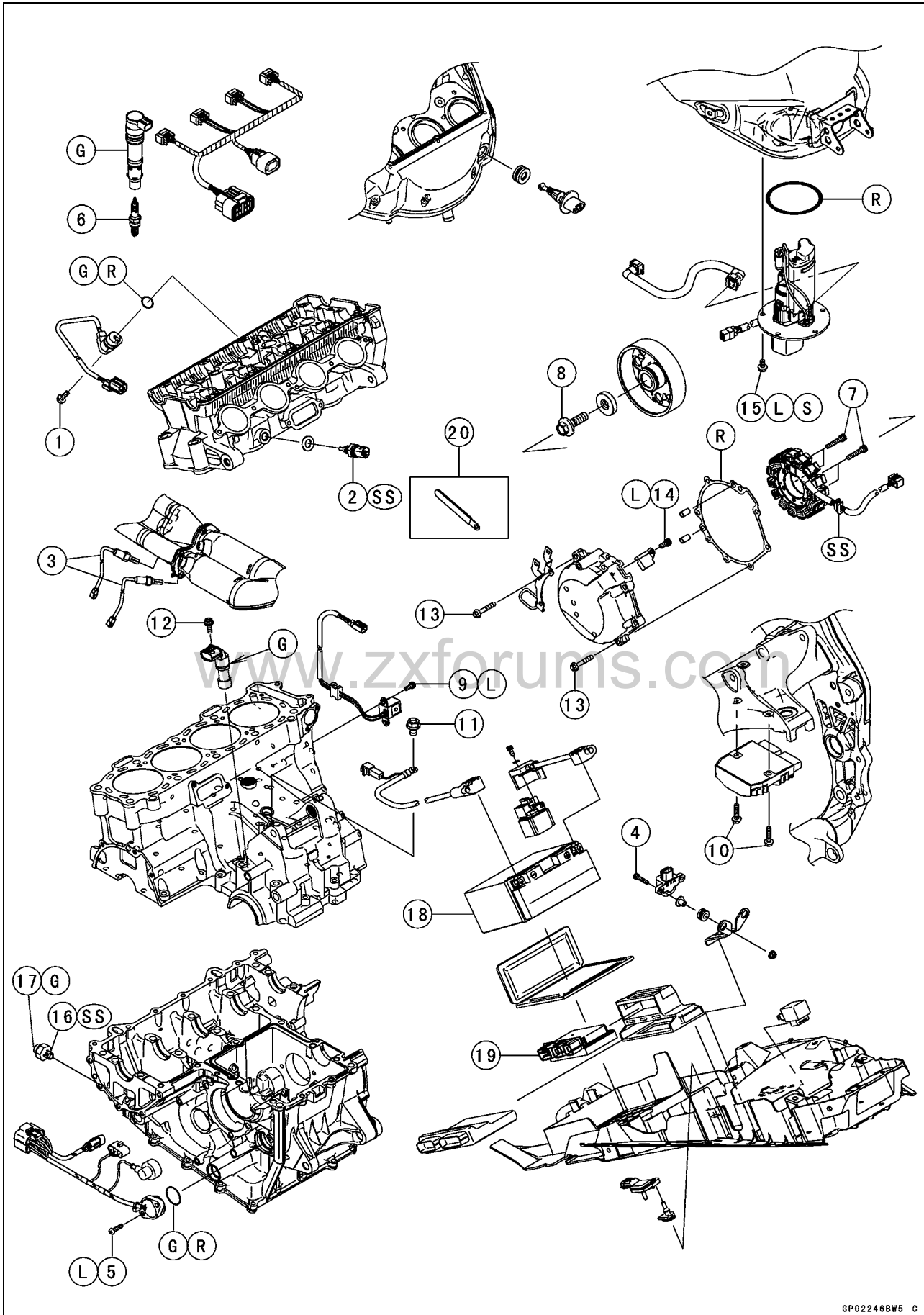

GP02246BW5 C

Exploded View

No.	Fastener	Torque			Remarks
		N·m	kgf·m	ft·lb	
1	Camshaft Position Sensor Bolt	10	1.0	89 in·lb	
2	Water Temperature Sensor	25	2.5	18	SS
3	Oxygen Sensors (Europe Models)	25	2.5	18	
4	Vehicle-down Sensor Bolts	6.0	0.61	53 in·lb	
5	Gear Position Switch Screws	3.0	0.31	27 in·lb	L
6	Spark Plugs	13	1.3	115 in·lb	
7	Stator Coil Bolts	12	1.2	106 in·lb	
8	Alternator Rotor Bolt	155	15.8	114	
9	Crankshaft Sensor Bolts	6.0	0.61	53 in·lb	L
10	Regulator/Rectifier Bolts	10	1.0	89 in·lb	
11	Frame Earth Mounting Bolt	10	1.0	89 in·lb	
12	Speed Sensor Bolt	10	1.0	89 in·lb	
13	Alternator Cover Bolts	10	1.0	89 in·lb	
14	Alternator Lead Holding Plate Bolt	10	1.0	89 in·lb	L
15	Fuel Pump Bolts	10	1.0	89 in·lb	L, S
16	Oil Pressure Switch	15	1.5	11	SS
17	Oil Pressure Switch Terminal Bolt	1.5	0.15	13 in·lb	G

18. Battery 12 V 10 Ah

19. ECU

20. Other than Europe Models

G: Apply grease.

L: Apply a non-permanent locking agent.

R: Replacement Parts

S: Follow the specified tighten sequence.

SS: Apply silicone sealant.

Exploded View

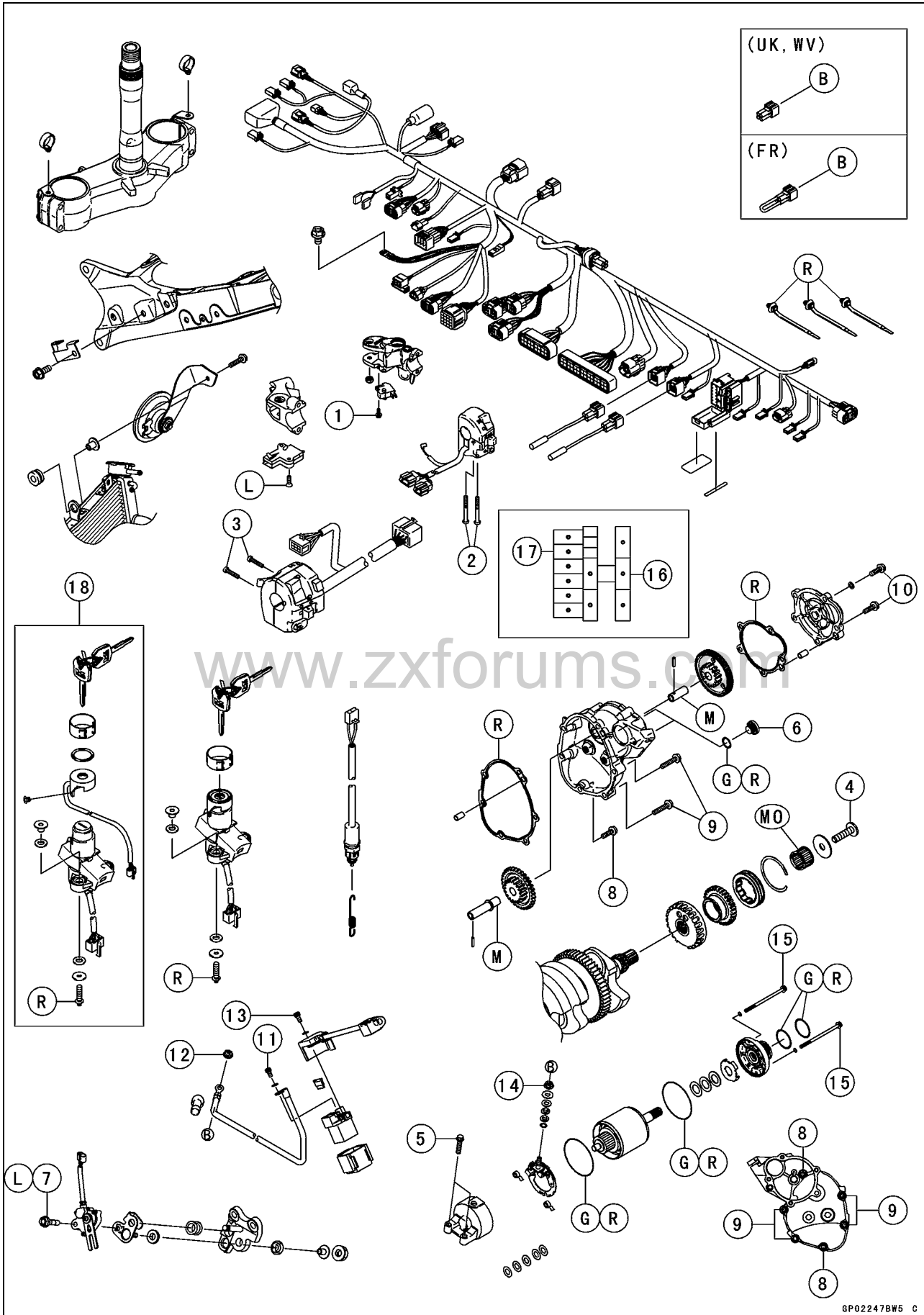

GP02247BW5 C

Exploded View

No.	Fastener	Torque			Remarks
		N·m	kgf·m	ft·lb	
1	Front Brake Light Switch Screw	1.2	0.12	11 in·lb	
2	Right Handlebar Switch Housing Screws (M5, L = 45)	3.5	0.36	31 in·lb	
3	Left Handlebar Switch Housing Screws (M5, L = 25)	3.5	0.36	31 in·lb	
4	Starter Clutch Bolt	49	5.0	36	
5	Starter Motor Mounting Bolts	10	1.0	89 in·lb	
6	Starter Clutch Bolt Cap	–	–	–	Hand-tighten
7	Sidestand Switch Bolt	8.8	0.90	78 in·lb	L
8	Starter Clutch Cover Bolts (M6, L = 20)	10	1.0	89 in·lb	
9	Starter Clutch Cover Bolts (M6, L = 30)	10	1.0	89 in·lb	
10	Idle Gear Cover Bolts	10	1.0	89 in·lb	
11	Starter Motor Cable Mounting Bolt	4.0	0.41	35 in·lb	
12	Starter Motor Cable Terminal Nut	6.0	0.61	53 in·lb	
13	Battery Cable Mounting Bolt	4.0	0.41	35 in·lb	
14	Starter Motor Terminal Locknut	6.9	0.70	61 in·lb	
15	Starter Motor Through Bolts	3.4	0.35	30 in·lb	

16. ECU Fuse 15 A

17. Fuse Box

18. Immobilizer Models

G: Apply grease.

L: Apply a non-permanent locking agent.

M: Apply molybdenum disulfide grease.

MO: Apply molybdenum disulfide oil solution.

(mixture of the engine oil and molybdenum disulfide grease in a weight ratio 10:1)

R: Replacement Parts

Parts Location

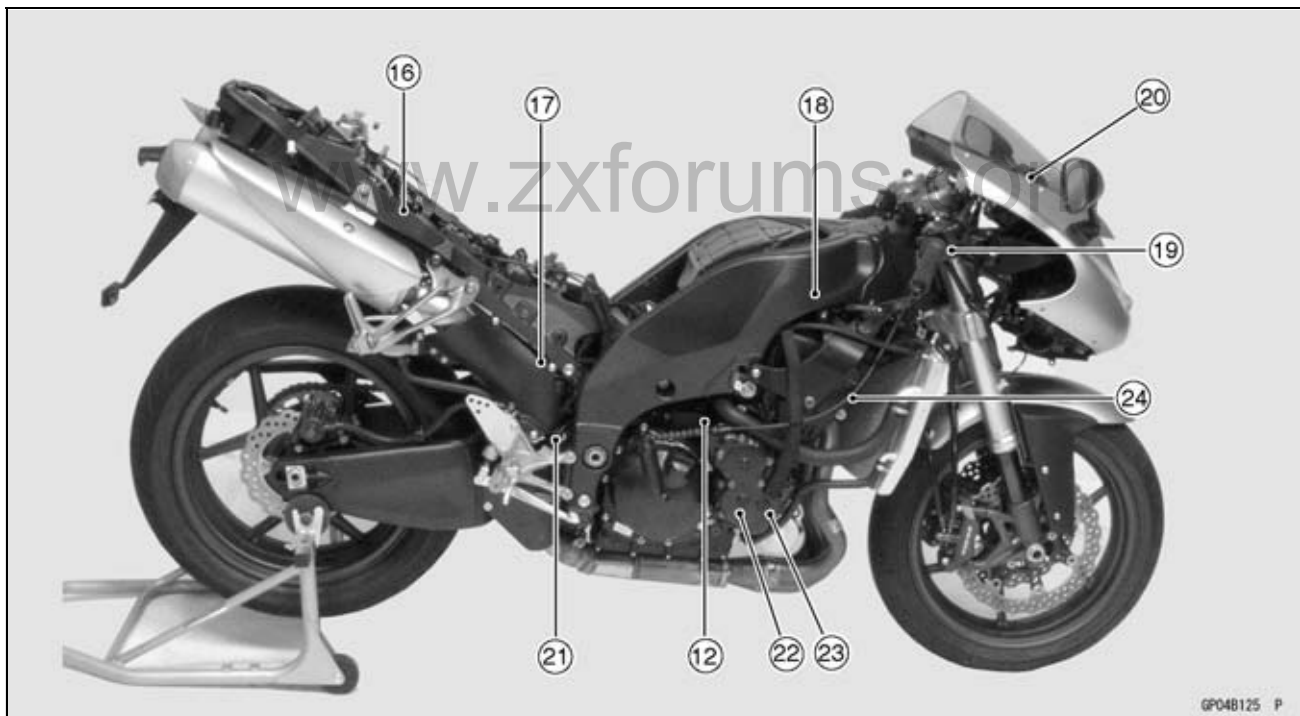
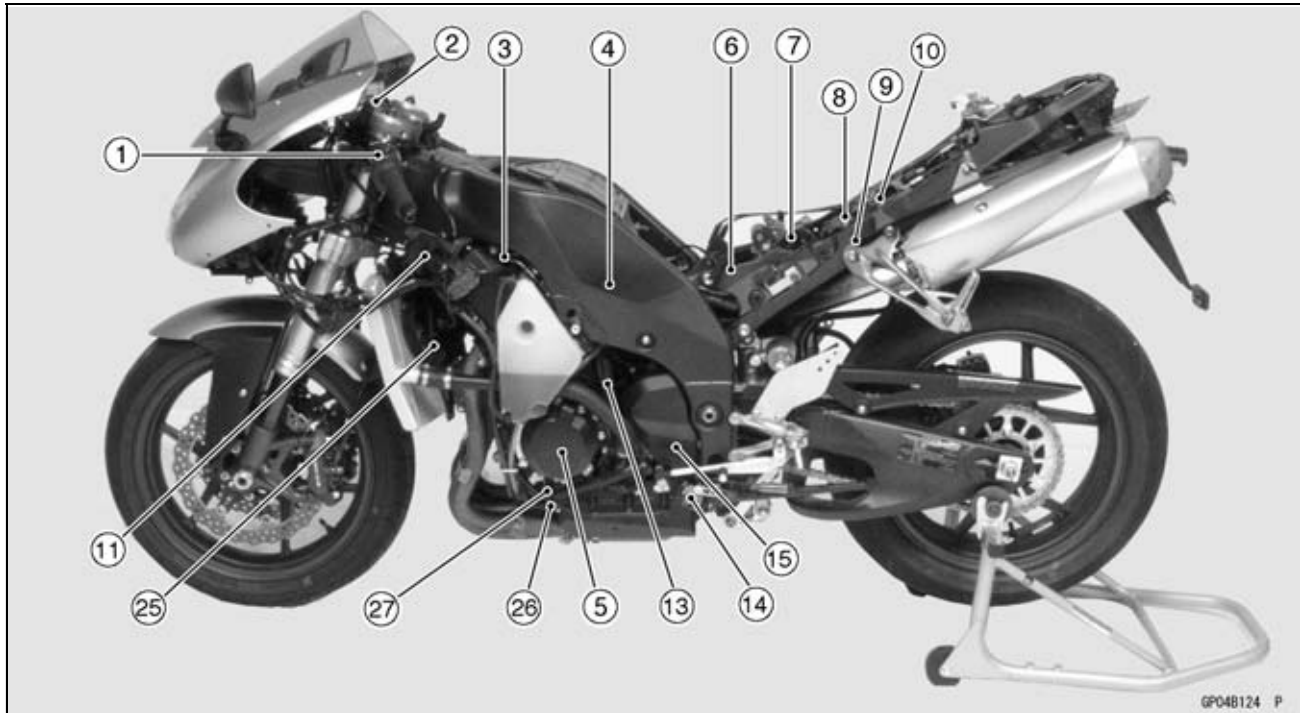

- | | |
|---|--------------------------------------|
| 1. Starter Lockout Switch | 14. Sidestand Switch |
| 2. Ignition Switch with Immobilizer Antenna (Im-
mobilizer Models) | 15. Gear Position Switch |
| 3. Stick Coils | 16. Turn Signal Relay |
| 4. Water Temperature Sensor | 17. Regulator/Rectifier |
| 5. Alternator | 18. Air Switching Valve |
| 6. Starter Relay with Main Fuse | 19. Front Brake Light Switch |
| 7. Battery 12 V 10 Ah | 20. Meter Unit |
| 8. Relay Box | 21. Rear Brake Light Switch |
| 9. ECU (Electric Control Unit) | 22. Starter Clutch |
| 10. Fuse Box with ECU Main Fuse | 23. Crankshaft Sensor |
| 11. Immobilizer Amplifier (Immobilizer Models) | 24. Camshaft Position Sensor |
| 12. Starter Motor | 25. Fan Motor |
| 13. Speed Sensor | 26. Oxygen Sensor #1 (Europe Models) |
| | 27. Oxygen Sensor #2 (Europe Models) |

Wiring Diagram (United States, Canada, New Zealand, Colombia and Taiwan)

Dummy Page

www.zxforums.com

Wiring Diagram (United States, Canada, New Zealand, Colombia and Taiwan)

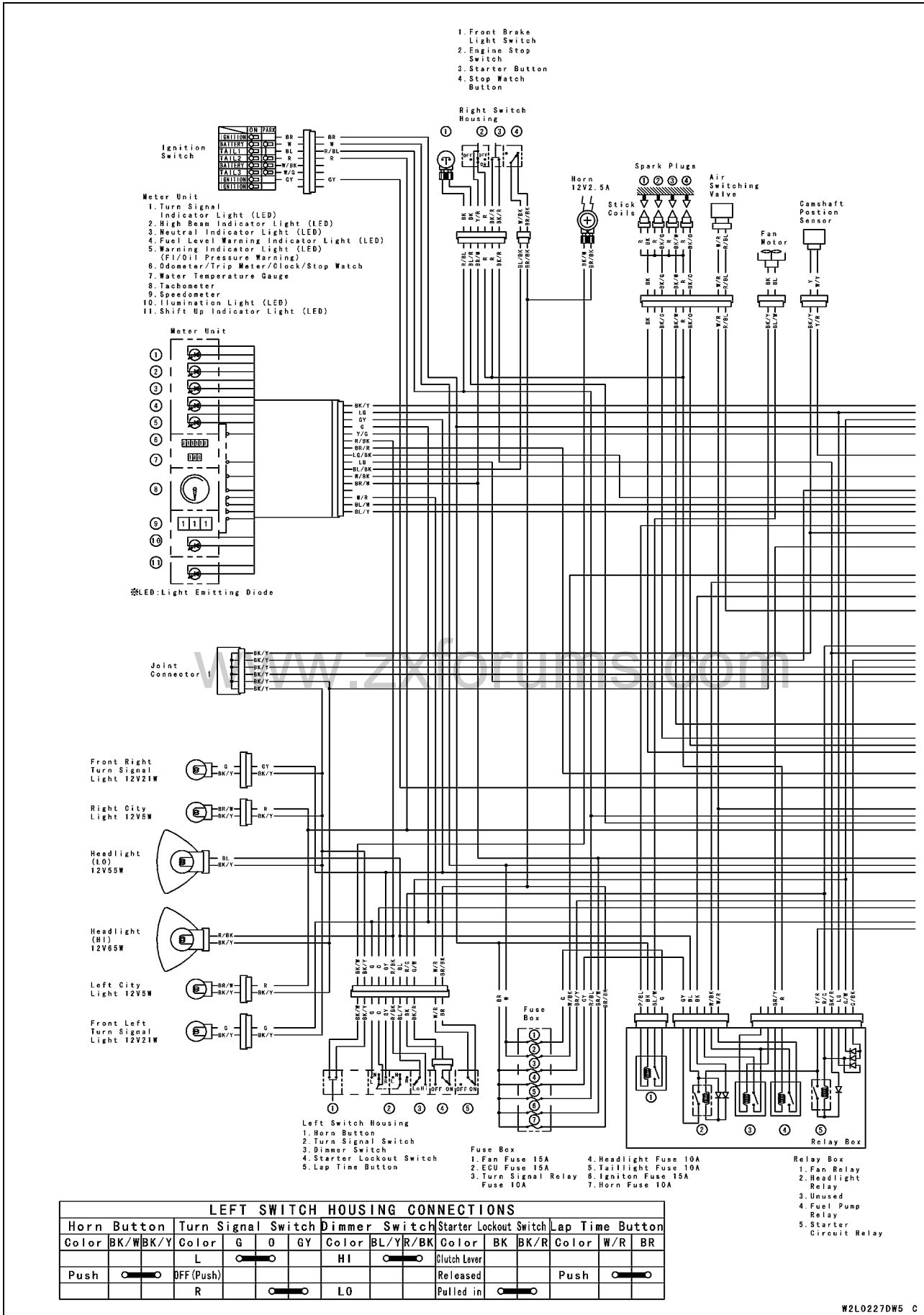

LEFT SWITCH HOUSING CONNECTIONS

Horn Button	Turn Signal Switch	Dimmer Switch	Starter Lockout Switch	Lap Time Button
Color BK/W/BK/Y	Color G O GY	Color BL/YR/BK	Color BK BK/R	Color W/R BR
Push	L	HI	Clutch Lever	Push
	OFF (Push)	LO	Released	
	R		Pulled in	

W2L0227DW5 C

Wiring Diagram (United States, Canada, New Zealand, Colombia and Taiwan)

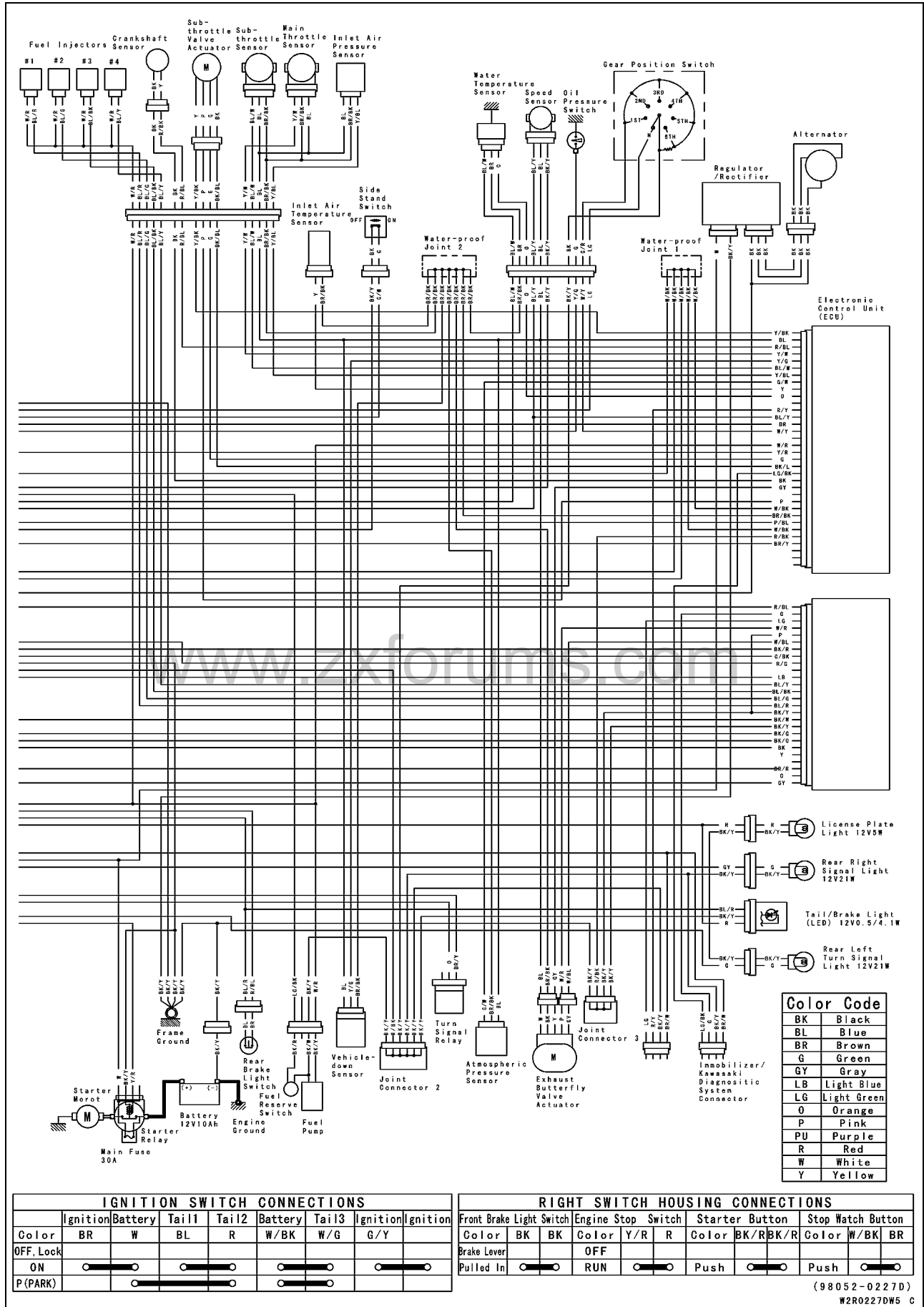

Wiring Diagram (Other than United States, Canada, New Zealand, Colombia, Taiwan, Australia and Malaysia)

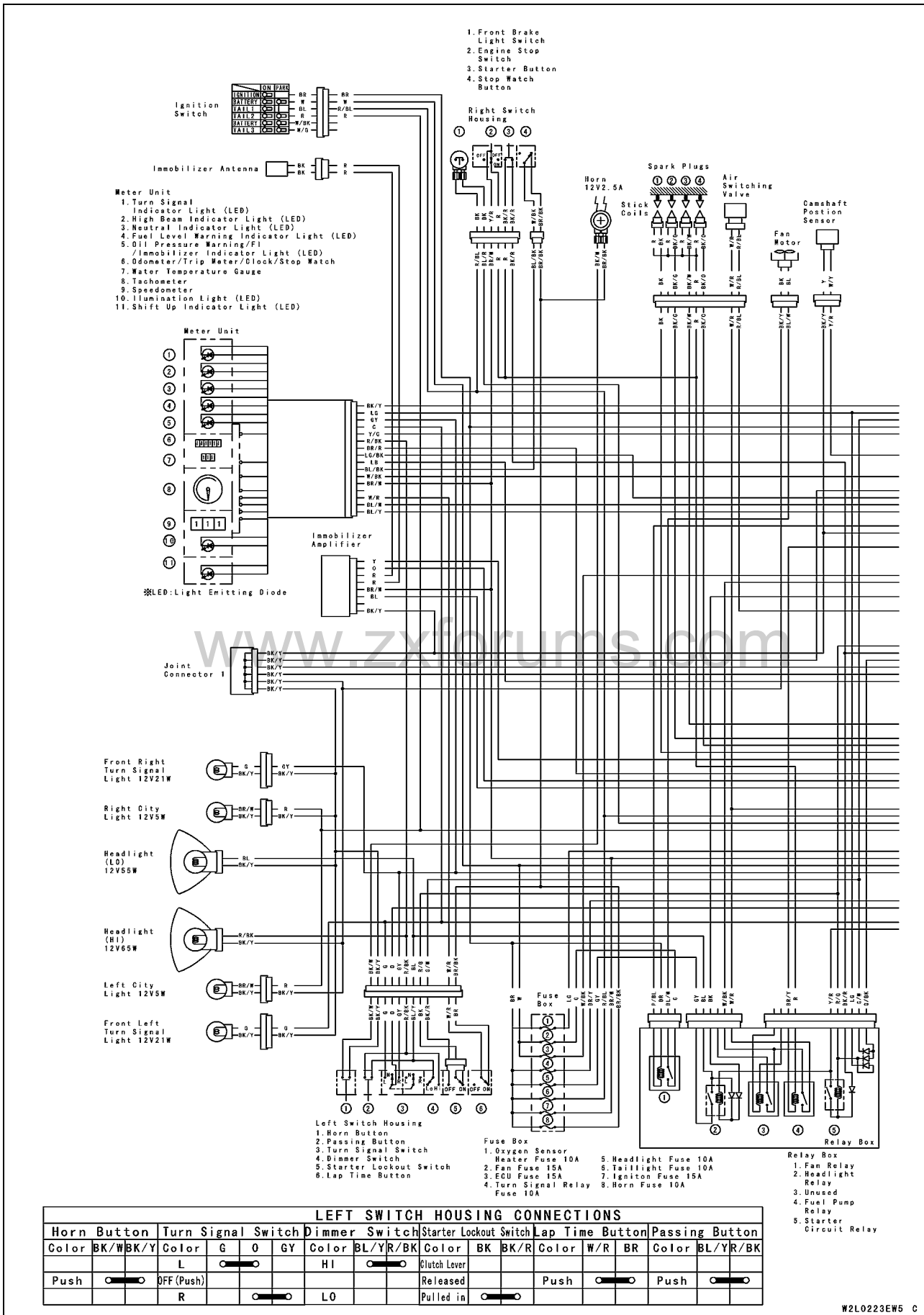

Wiring Diagram (Other than United States, Canada, New Zealand, Colombia, Taiwan, Australia and Malaysia)

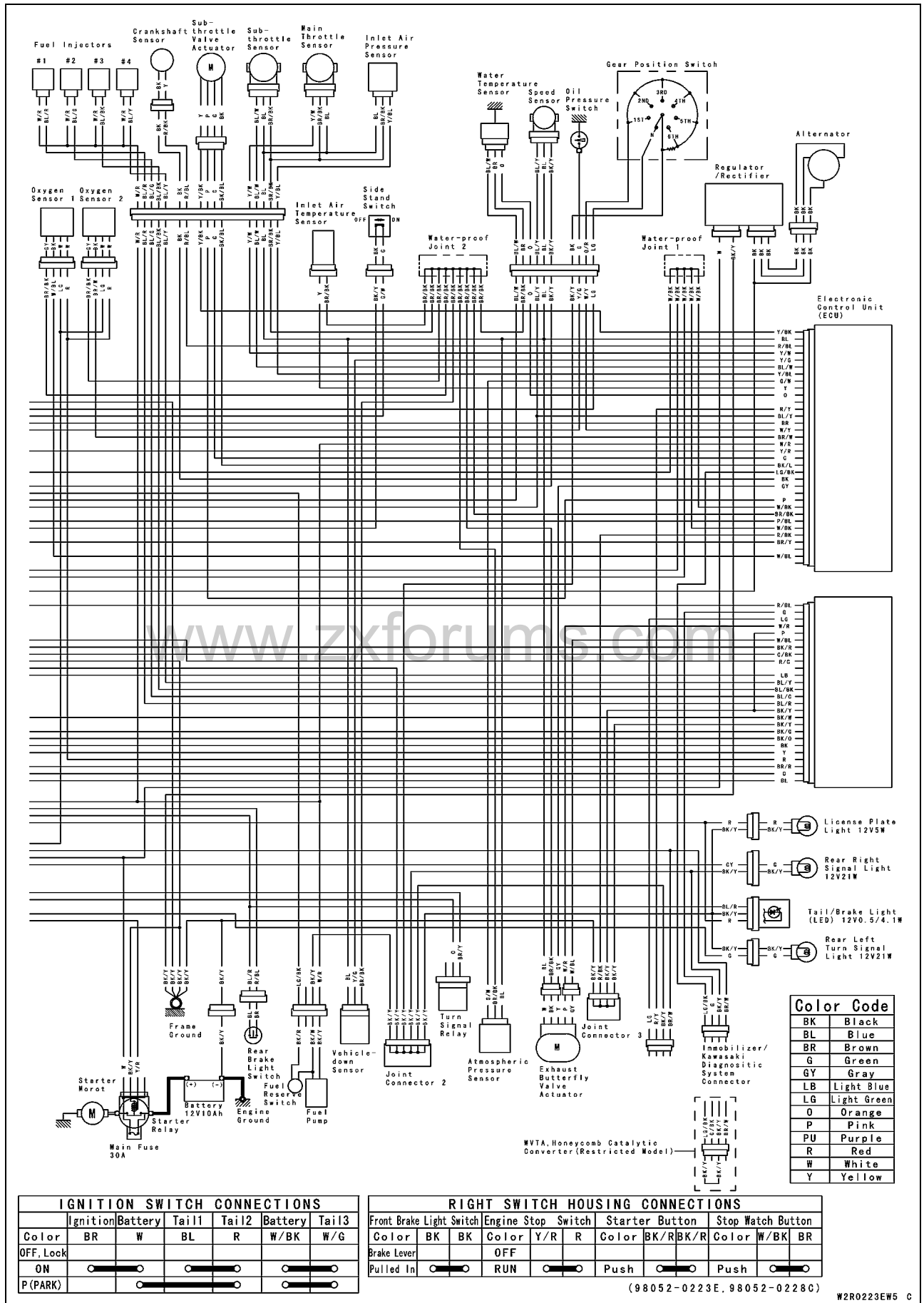

Wiring Diagram (Australia)

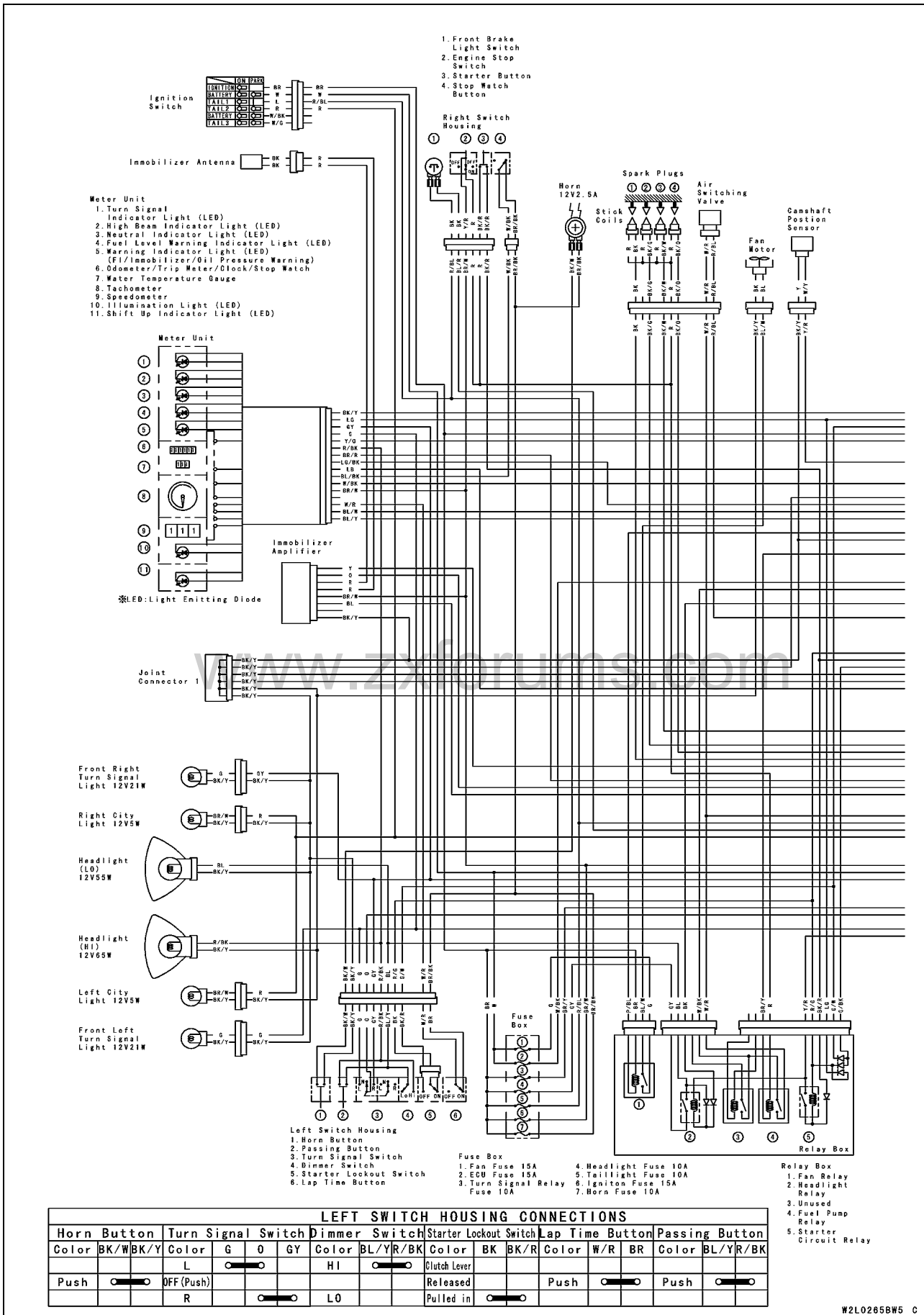

LEFT SWITCH HOUSING CONNECTIONS

Horn Button	Turn Signal Switch	Dimmer Switch	Starter Lockout Switch	Lap Time Button	Passing Button
Color BK/W/BK/Y	Color G O GY	Color BL/YR/BK	Color BK BK/R	Color W/R BR	Color BL/YR/BK
Push	OFF (Push)	Clutch Lever	Released	Push	Push
	R	L0	Pulled in		

W2L0265BW5 C

Wiring Diagram (Australia)

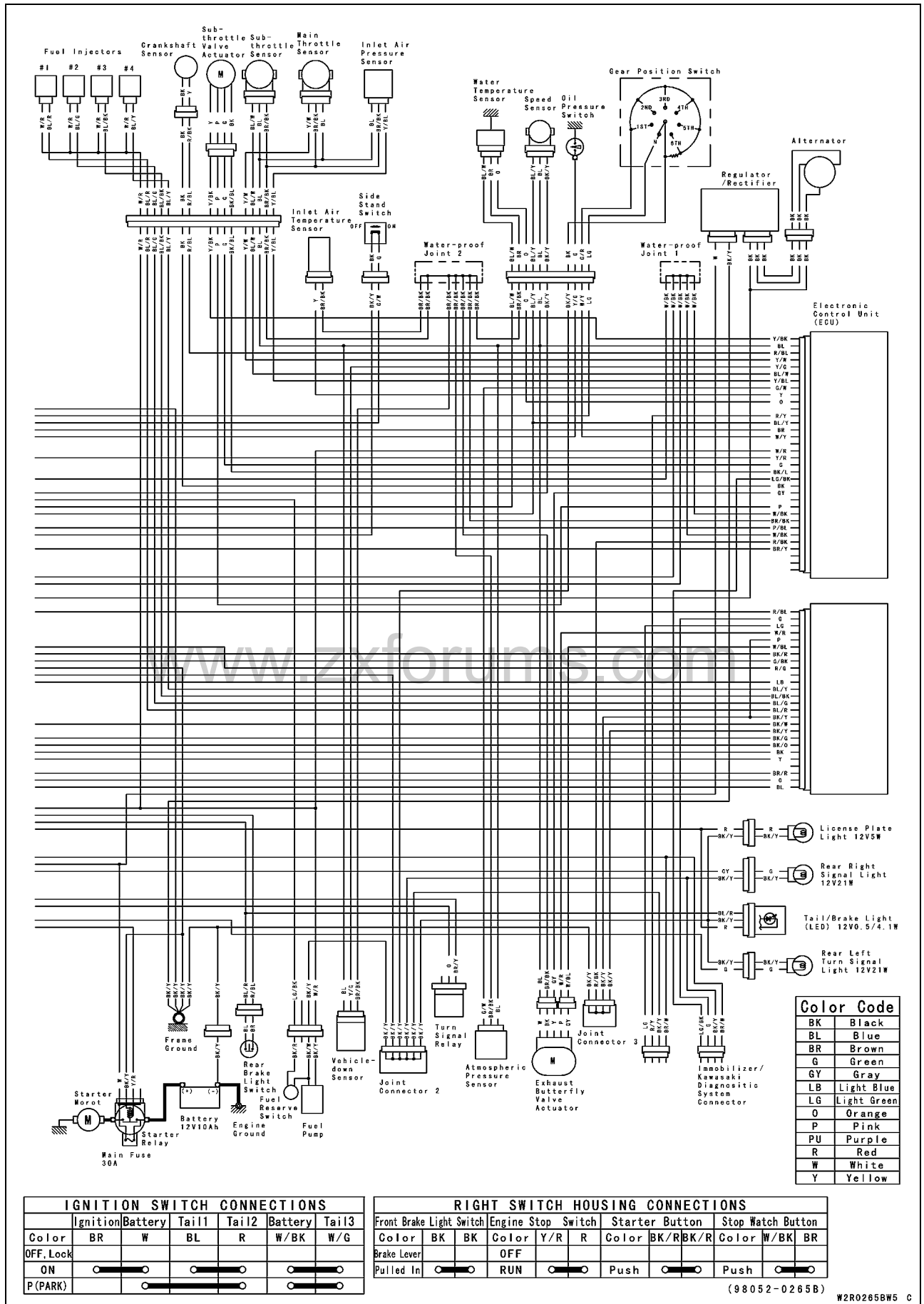

Wiring Diagram (Malaysia)

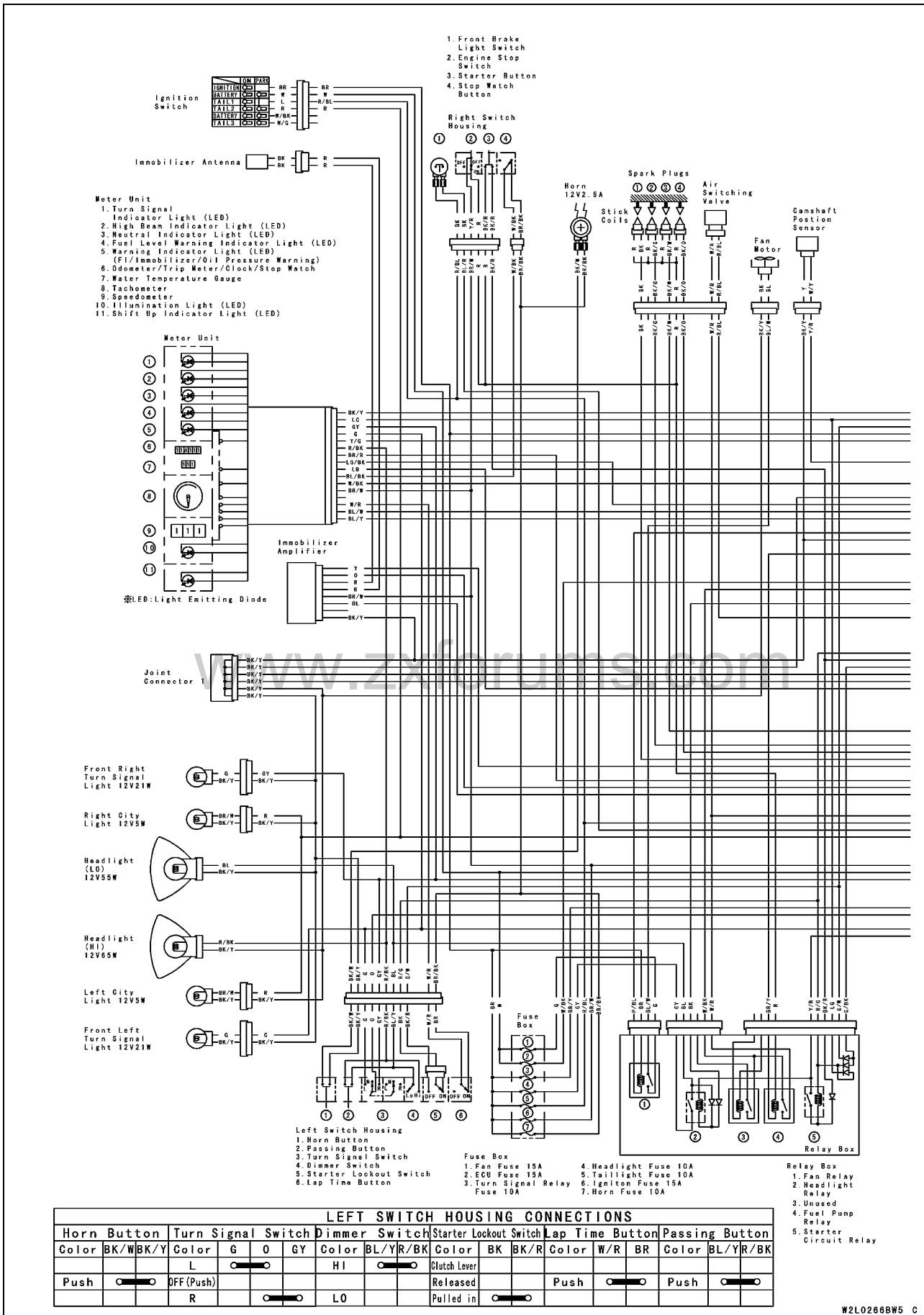

W2L0266BW5 C

Wiring Diagram (Malaysia)

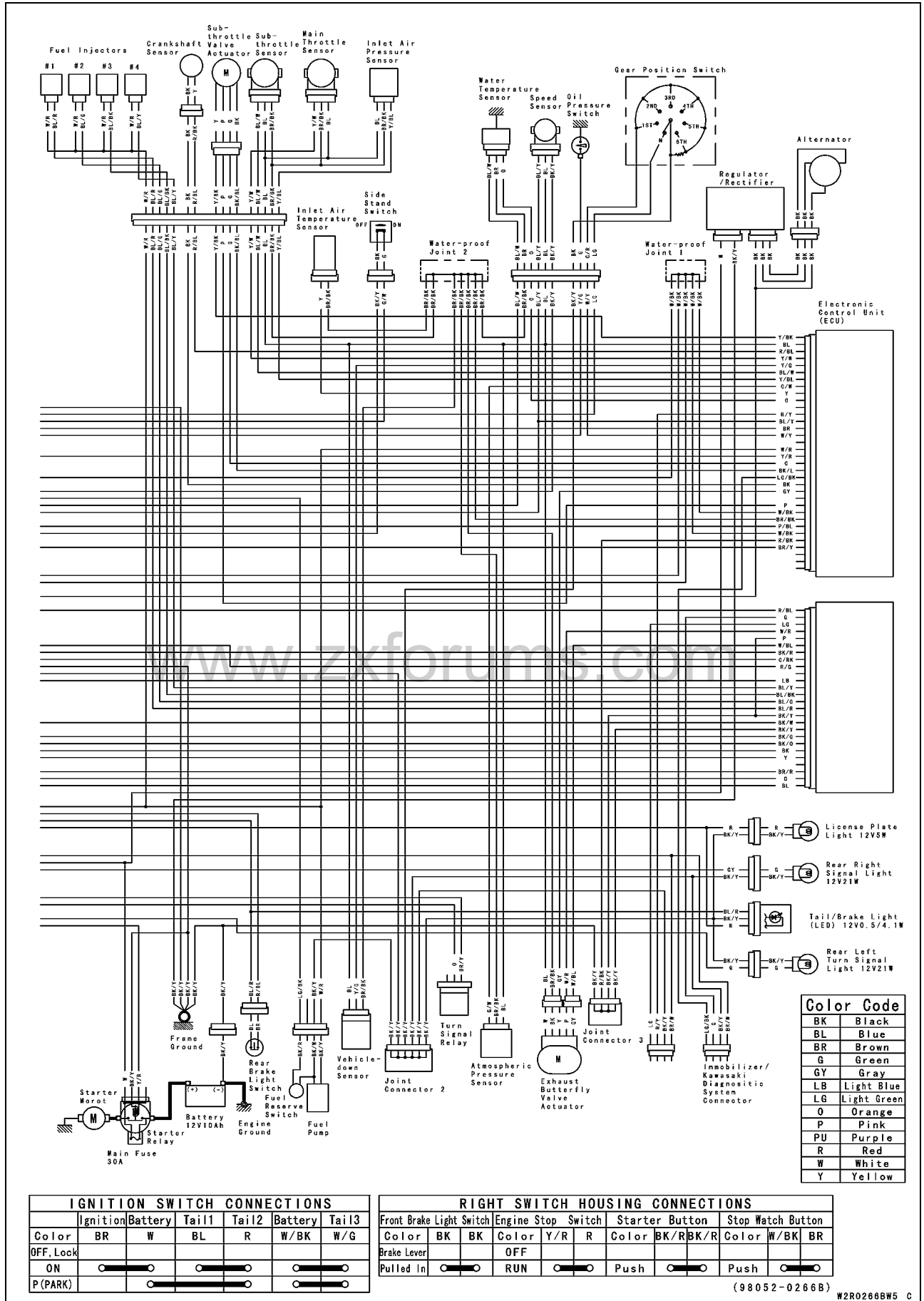

Specifications

Item	Standard
<p>Battery</p> <p>Type</p> <p>Model Name</p> <p>Capacity</p> <p>Voltage</p>	<p>Sealed battery</p> <p>YT12B-BS</p> <p>12 V 10 Ah</p> <p>12.8 V or more</p>
<p>Charging System</p> <p>Type</p> <p>Alternator Output Voltage</p> <p>Stator Coil Resistance</p> <p>Charging Voltage (Regulator/Rectifier Output Voltage)</p>	<p>Three-phase AC</p> <p>60 V or more @4 000 r/min (rpm)</p> <p>0.1 ~ 0.2 Ω</p> <p>14.2 ~ 15.2 V</p>
<p>Ignition System</p> <p>Crankshaft Sensor Resistance</p> <p>Crankshaft Sensor Peak Voltage</p> <p>Camshaft Position Sensor Resistance</p> <p>Camshaft Position Sensor Peak Voltage</p> <p>Spark Plug Gap</p> <p>Stick Coil:</p> <p> Primary Winding Resistance</p> <p> Secondary Winding Resistance</p> <p> Primary Peak Voltage</p>	<p>380 ~ 570 Ω</p> <p>3.2 V or more</p> <p>400 ~ 460 Ω</p> <p>0.4 V or more</p> <p>0.8 ~ 0.9 mm (0.032 ~ 0.035 in.)</p> <p>1.2 ~ 1.6 Ω</p> <p>8.5 ~ 11.5 kΩ</p> <p>72 V or more</p>
<p>Electric Starter System</p> <p>Starter Motor:</p> <p> Brush Length</p> <p> Commutator Diameter</p>	<p>10 mm (0.39 in.), Service limit 5.0 mm (0.20 in.)</p> <p>28 mm (1.10 in.), Service limit 27 mm (1.06 in.)</p>
<p>Air Switching Valve</p> <p>Resistance</p>	<p>18 ~ 22 Ω at 20°C (68°F)</p>
<p>Switch and Sensor</p> <p>Rear Brake Light Switch Timing</p> <p>Engine Oil Pressure Switch Connections</p> <p>Water Temperature Sensor Resistance</p>	<p>ON after about 10 mm (0.39 in.) pedal travel</p> <p>When engine is stopped: ON</p> <p>When engine is running: OFF</p> <p>In the text</p>

Special Tools and Sealant

Hand Tester:
57001-1394

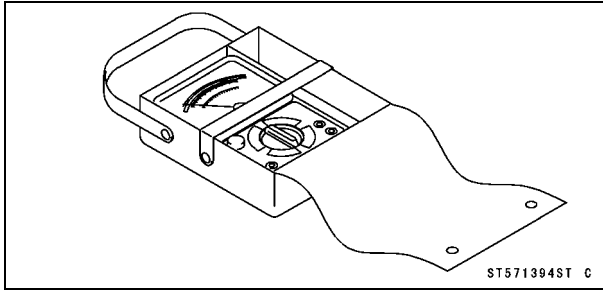

Grip:
57001-1591

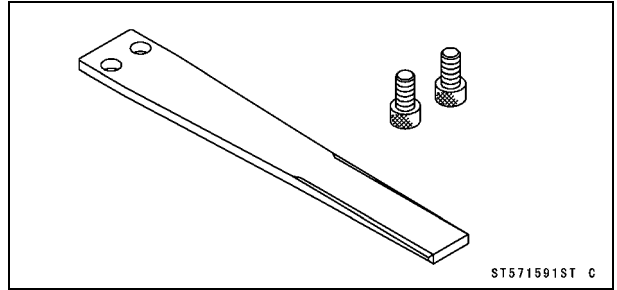

Flywheel Puller Assembly, M38 x 1.5/M35 x 1.5:
57001-1405

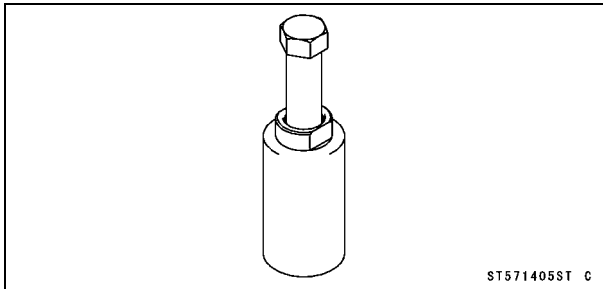

Rotor Holder:
57001-1658

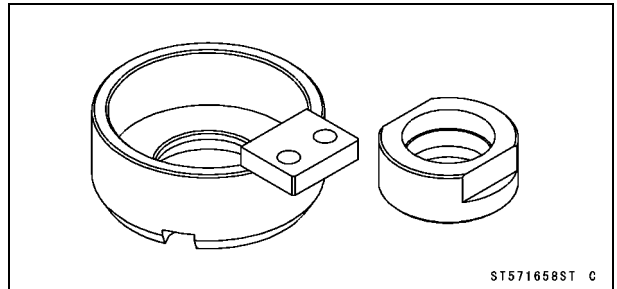

Peak Voltage Adapter:
57001-1415

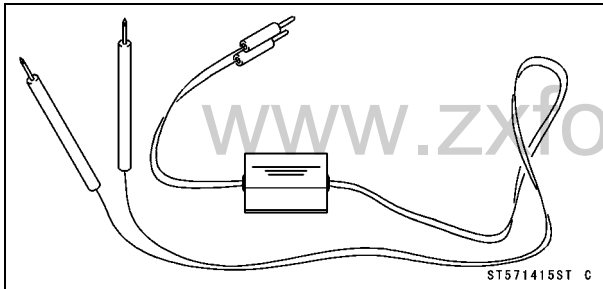

Rotor Holder:
57001-1666

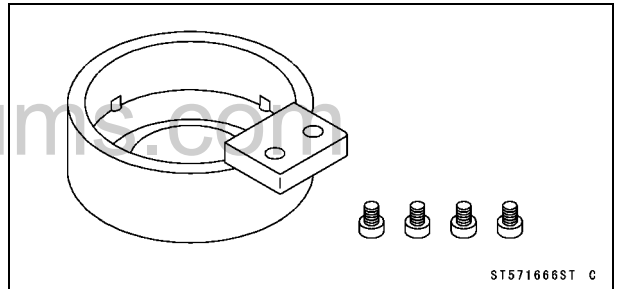

Lead Wire - Peak Voltage Adapter:
57001-1449

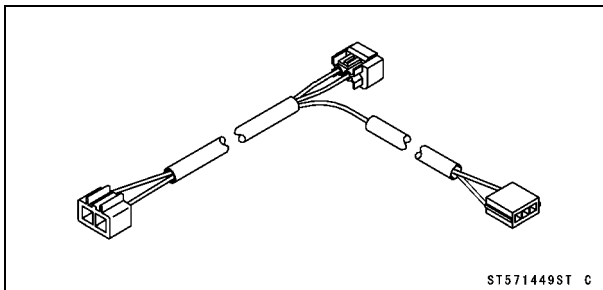

Kawasaki Bond (Silicone Sealant):
92104-0004

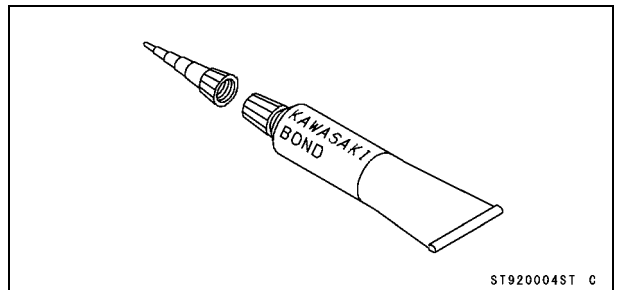

Key Registration Unit:
57001-1582

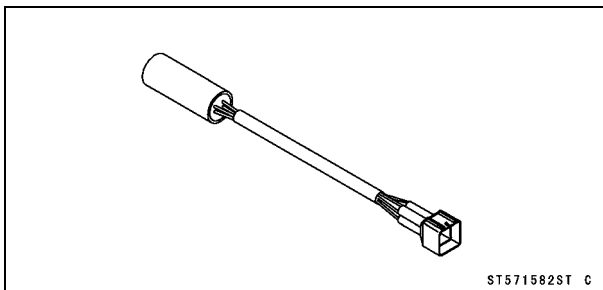

Precautions

There are a number of important precautions that are musts when servicing electrical systems. Learn and observe all the rules below.

- Do not reverse the battery lead connections. This will burn out the diodes on the electrical parts.
- Always check battery condition before condemning other parts of an electrical system. A fully charged battery is a must for conducting accurate electrical system tests.
- The electrical parts should never be struck sharply, as with a hammer, or allowed to fall on a hard surface. Such a shock to the parts can damage them.
- To prevent damage to electrical parts, do not disconnect the battery leads or any other electrical connections when the ignition switch is on, or while the engine is running.
- Because of the large amount of current, never keep the starter button pushed when the starter motor will not turn over, or the current may burn out the starter motor windings.
- Do not use a meter illumination bulb rated for other than voltage or wattage specified in the wiring diagram, as the meter or gauge panel could be warped by excessive heat radiated from the bulb.
- Take care not to short the leads that are directly connected to the battery positive (+) terminal to the chassis ground.
- Troubles may involve one or in some cases all items. Never replace a defective part without determining what CAUSED the failure. If the failure was caused by some other item or items, they must be repaired or replaced, or the new replacement will soon fail again.
- Make sure all connectors in the circuit are clean and tight, and examine wires for signs of burning, fraying, etc. Poor wires and bad connections will affect electrical system operation.
- Measure coil and winding resistance when the part is cold (at room temperature).

○ Color Codes:

BK: Black	G: Green	P: Pink
BL: Blue	GY: Gray	PU: Purple
BR: Brown	LB: Light Blue	R: Red
CH: Chocolate	LG: Light Green	W: White
DG: Dark Green	O: Orange	Y: Yellow

○ Electrical Connectors

Female Connectors [A]

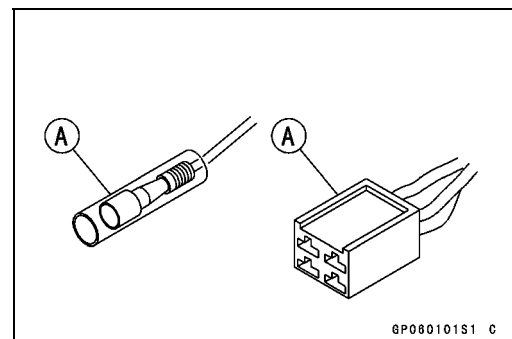

Precautions

Male Connectors [B]

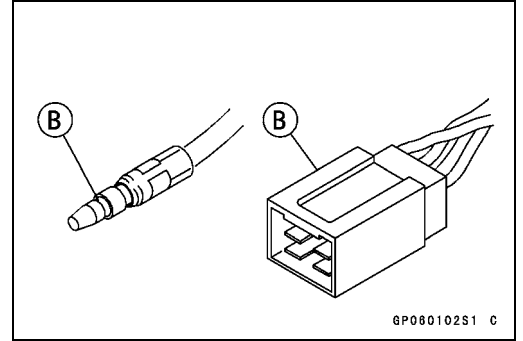

www.zxforums.com

Electrical Wiring

Wiring Inspection

- Visually inspect the wiring for signs of burning, fraying, etc.
- ★ If any wiring is poor, replace the damaged wiring.
- Pull each connector [A] apart and inspect it for corrosion, dirt, and damage.
- ★ If the connector is corroded or dirty, clean it carefully. If it is damaged, replace it.
- Check the wiring for continuity.
- Use the wiring diagram to find the ends of the lead which is suspected of being a problem.
- Connect the hand tester between the ends of the leads.

Special Tool - Hand Tester: 57001-1394

- Set the tester to the $\times 1 \Omega$ range, and read the tester.
- ★ If the tester does not read 0Ω , the lead is defective. Replace the lead or the wiring harness [B] [C] [D] if necessary.

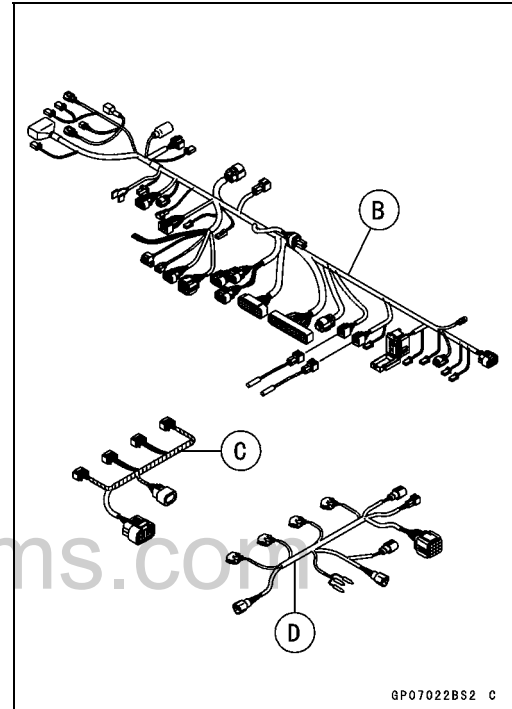
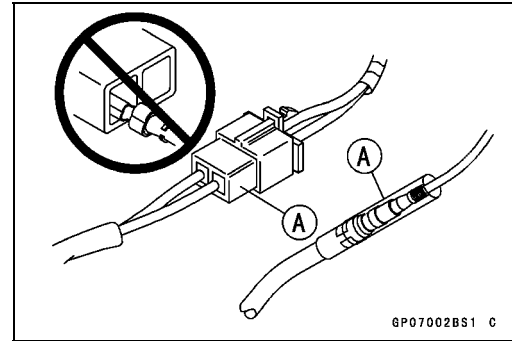

Battery

Battery Removal

- Remove:
 - Front Seat (see Front Seat Removal in the Frame chapter)
 - Relay Box [A]

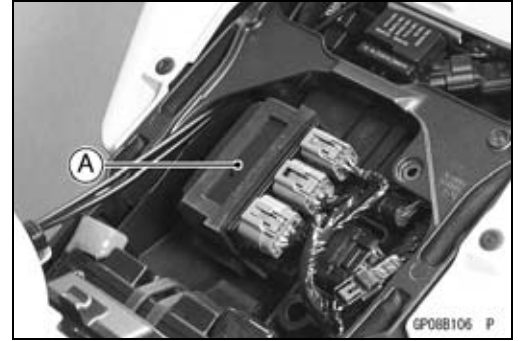

- Slide the black and red caps [A] out.
- Disconnect the negative (-) cable [B] and then positive (+) cable [C].

CAUTION
Be sure to disconnect the negative (-) cable first.

- Remove the band [D].
- Pull the battery [A] out of the case.

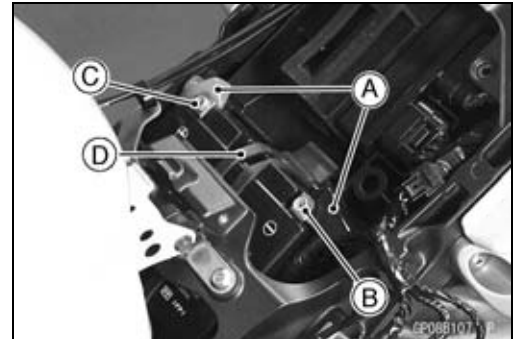

www.zxforums.com

Battery Installation

- Visually inspect the surface of the battery container.
- ★ If any signs of cracking or electrolyte leakage from the sides of the battery.
- Face the (+) terminal upward, and put the battery into the rear fender front.
- Install the band [A].
- Connect the positive cable [B] (red cap) to the (+) terminal first, and then the negative cable [C] (black cap) to the (-) terminal.
- Apply a light coat of grease on the terminals to prevent corrosion.
- Cover the terminals with the black and red caps [D].

CAUTION
If each battery cable is not correctly disconnected or connected, sparks can arise at electrical connections, causing damage to electrical and DFI parts.

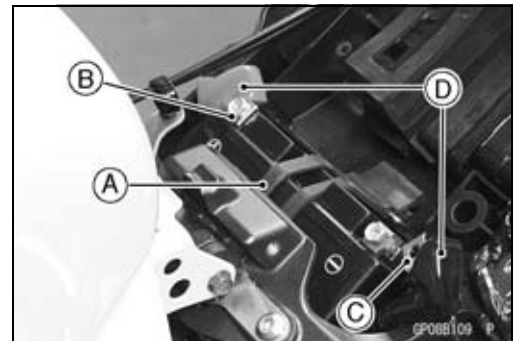

Battery

Battery Activation

Electrolyte Filling

- Make sure that the model name [A] of the electrolyte container matches the model name [B] of the battery. These names must be the same.

Battery Model Name for ZX1000D: YT12B-BS

CAUTION

Be sure to use the electrolyte container with the same model name as the battery since the electrolyte volume and specific gravity vary with the battery type. This is to prevent overfilling of the electrolyte, shorting the battery life, and deterioration of the battery performance.

CAUTION

Do not remove the aluminum sealing sheet [A] from the filler ports [B] until just prior to use. Be sure to use the dedicated electrolyte container for correct electrolyte volume.

- Place the battery on a level surface.
- Check to see that the sealing sheet has no peeling, tears, or holes in it.
- Remove the sealing sheet.

NOTE

○The battery is vacuum sealed. If the sealing sheet has leaked air into the battery, it may require a longer initial charge.

- Remove the electrolyte container from the vinyl bag.
- Detach the strip of caps [A] from the container and set aside, these will be used later to seal the battery.

NOTE

○Do not pierce or otherwise open the sealed cells [B] of the electrolyte container. Do not attempt to separate individual cells.

- Place the electrolyte container upside down with the six sealed cells into the filler ports of the battery. Hold the container level, push down to break the seals of all six cells. You will see air bubbles rising into each cell as the ports fill.

NOTE

○Do not tilt the electrolyte container

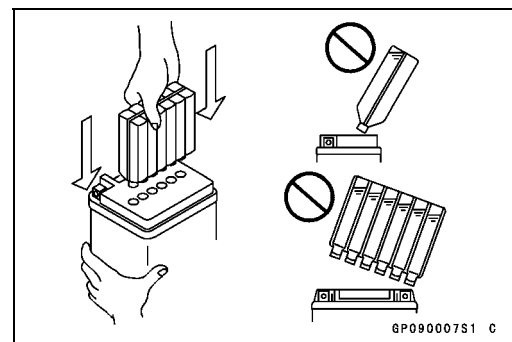
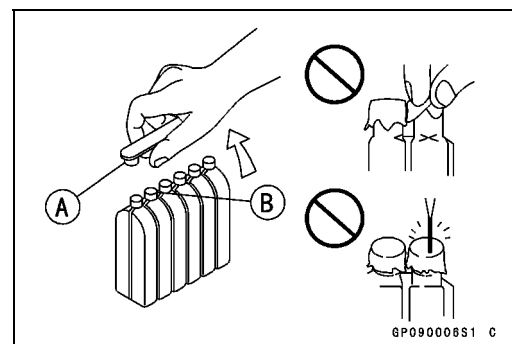
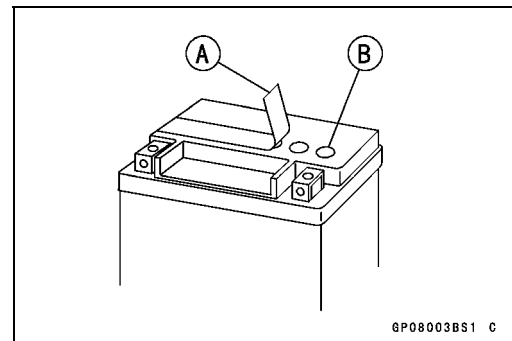
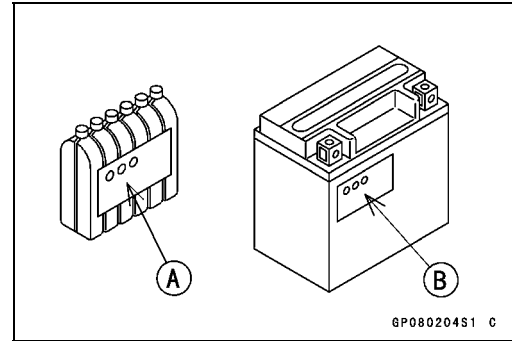

Battery

- Check the electrolyte flow.
- ★ If no air bubbles [A] are coming up from the filler ports, or if the container cells have not emptied completely, tap the container [B] a few times.
- Keep the container in place for **20** minutes or more. Don't remove the container from the battery until it's empty, the battery requires all the electrolyte from the container for proper operation.

CAUTION

Removal of the container before it is completely empty can shorten the service life of the battery. Do not remove the electrolyte container until it is completely empty and 20 minutes have elapsed.

- Gently remove the container from the battery.
- Let the battery sit for **30** minutes prior to charging to allow the electrolyte to permeate into the plates for optimum performance.

NOTE

○ *Charging the battery immediately after filling can shorten service life. Let the battery sit for at least 30 minutes after filling.*

Initial Charge

- Place the strip [A] of caps loosely over the filler ports.
- Newly activated sealed batteries require an initial charge.

Standard Charge: 1.2 A × 5 ~ 10 hours

- ★ If using a recommended battery charger, follow the charger's instructions for newly activated sealed battery.

Kawasaki-recommended chargers:

Optimate III

Yuasa 1.5 Amp Automatic Charger

Battery Mate 150-9

- ★ If the above chargers are not available, use equivalent one.

NOTE

○ *Charging rates will vary depending on how long the battery has been stored, temperature, and the type of charger used. Let battery sit 30 minutes after initial charge, then check voltage using a voltmeter. If it is not at least 12.8 volts, repeat charging cycle.*

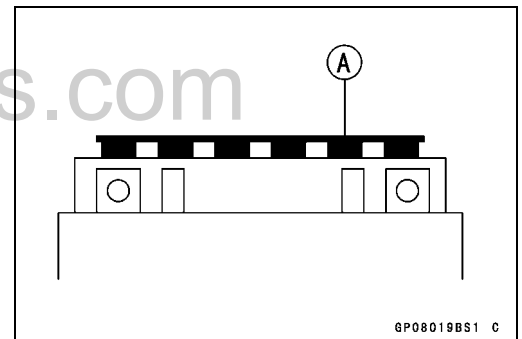
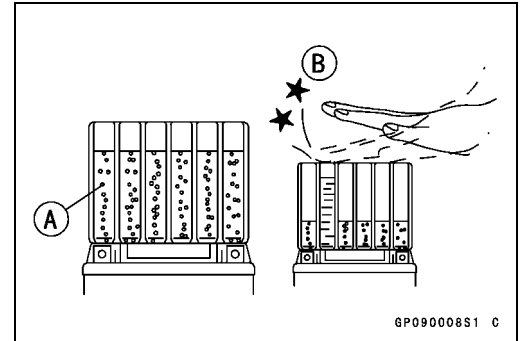

Battery

- After charging is completed, press down firmly with both hands to seat the strip of caps [A] into the battery (don't pound or hammer). When properly installed, the strip of the caps will be level with the top of the battery.

CAUTION

Once the strip of the caps [A] is installed onto the battery, never remove the caps, nor add water or electrolyte to the battery.

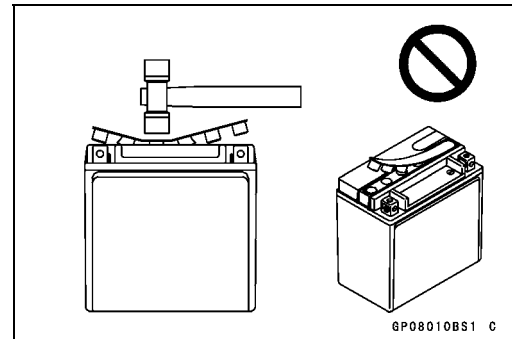
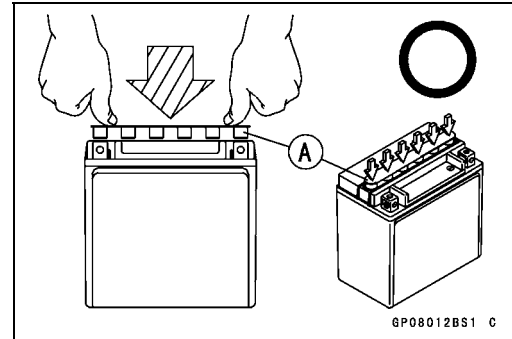

NOTE

○ To ensure maximum battery life and customer satisfaction, it is recommended the battery be load tested at three times its amp-hour rating for 15 seconds.

Re-check voltage and if less than 12.8 volts repeat the charging cycle and load test. If still below 12.8 volts the battery is defective.

Precautions

1) No need of topping-up

No topping-up is necessary in this battery until it ends its life under normal use. Forcibly prying off the seal cap to add water is very dangerous. Never do that.

2) Refreshing charge

If an engine will not start, a horn sounds weak, or lamps are dim, it indicates the battery has been discharged. Give refresh charge for 5 to 10 hours with charge current shown in the specification (see this chapter).

When a fast charge is inevitably required, do it following precisely the maximum charge current and time conditions indicated on the battery.

CAUTION

This battery is designed to sustain no unusual deterioration if refresh-charged according to the method specified above. However, the battery's performance may be reduced noticeably if charged under conditions other than given above. Never remove the seal cap during refresh charge.

If by chance an excessive amount of gas is generated due to overcharging, the relief valve releases the gas to keep the battery normal.

3) When you do not use the motorcycle for months:

Give a refresh charge before you store the motorcycle and store it with the negative cable removed. Give a refresh charge **once a month** during storage.

4) Battery life:

If the battery will not start the engine even after several refresh charges, the battery has exceeded its useful life. Replace it (Provided, however, the vehicle's starting system has no problem).

Battery

⚠ WARNING

Keep the battery away from sparks and open flames during charging, since the battery gives off an explosive gas mixture of hydrogen and oxygen. When using a battery charger, connect the battery to the charger before turning on the charger.

This procedure prevents sparks at the battery terminals which could ignite any battery gases.

No fire should be drawn near the battery, or no terminals should have the tightening loosened.

The electrolyte contains sulfuric acid. Be careful not to have it touch your skin or eyes. If touched, wash it off with liberal amount of water. Get medical attention if severe.

Interchange

A sealed battery can fully display its performance only when combined with a proper vehicle electric system. Therefore, replace a sealed battery only on a motorcycle which was originally equipped with a sealed battery.

Be careful, if a sealed battery is installed on a motorcycle which had an ordinary battery as original equipment, the sealed battery's life will be shortened.

Charging Condition Inspection

- Battery charging condition can be checked by measuring battery terminal voltage with a digital voltmeter [A].
- Remove:
 - Front Seat (see Front Seat Removal Frame chapter)
 - Battery Cable Caps (see Battery Removal)
- Disconnect the battery terminals.

CAUTION

Be sure to disconnect the negative (-) cable first.

- Measure the battery terminal voltage.

NOTE

○ Measure with a digital voltmeter which can be read one decimal place voltage.

- ★ If the reading is 12.8 V or more, no refresh charge is required, however, if the read is below the specified, refresh charge is required.

Battery Terminal Voltage

Standard: 12.8 V or more

Terminal Voltage (V) [A]

Battery Charge Rate (%) [B]

Good [C]

Refresh charge is required [D]

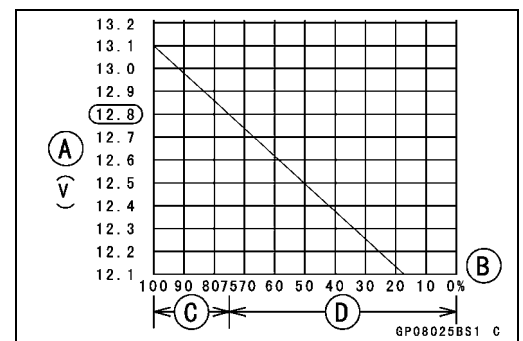
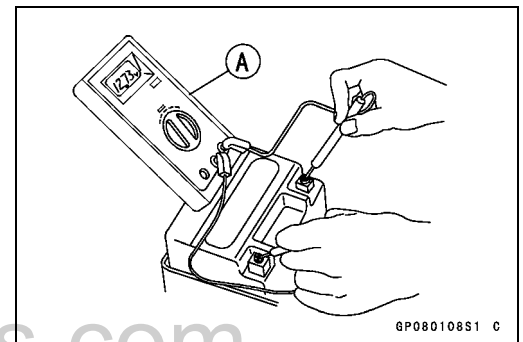

Refreshing Charge

- Remove the battery [A] (see Battery Removal).
- Do refresh charge by following method according to the battery terminal voltage.

⚠ WARNING

This battery is sealed type. Never remove sealing cap [B] even at charging. Never add water. Charge with current and time as stated below.

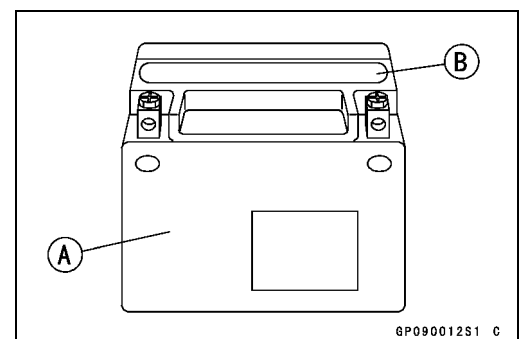

Battery

Terminal Voltage: 11.5 ~ less than 12.8 V
 Standard Charge 1.2 A × 5 ~ 10 h (see following chart)
 Quick Charge 5 A × 1 h

CAUTION

If possible, do not quick charge. If quick charge is done unavoidably, do standard charge later on.

Terminal Voltage: less than 11.5 V
 Charging Method: 1.2 A × 20 h

NOTE

○ Increase the charging voltage to a maximum voltage of 25 V if the battery will not accept current initially. Charge for no more than 5 minutes at the increased voltage then check if the battery is drawing current. If the battery will accept current decrease the voltage and charge by the standard charging method described on the battery case. If the battery will not accept current after 5 minutes, replace the battery.

- Battery [A]
- Battery Charger [B]
- Standard Value [C]
- Current starts to flow [D]

- Determine the battery condition after refresh charge.
- Determine the condition of the battery left for 30 minutes after completion of the charge by measuring the terminal voltage according to the table below.

Criteria	Judgement
12.8 V or higher	Good
12.0 ~ lower than 12.8 V	Charge insufficient → Recharge
lower than 12.0 V	Unserviceable → Replace

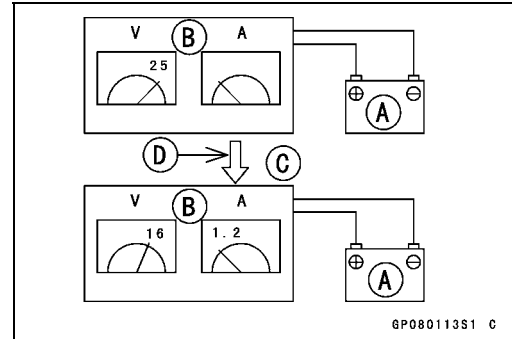
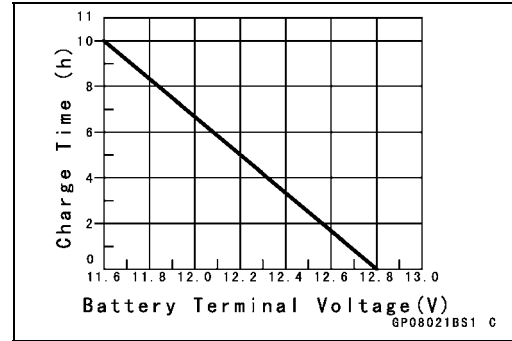

Charging System

Alternator Cover Removal

- Remove:
 - Left Middle Fairing (see Middle Fairing Removal in the Frame chapter)
 - Coolant Reserve Tank (see Coolant Reserve Tank Removal in the Cooling System chapter)
 - Fuel Tank (see Fuel Tank Removal in the Fuel System (DFI) chapter)
 - Alternator Lead Connector [A]

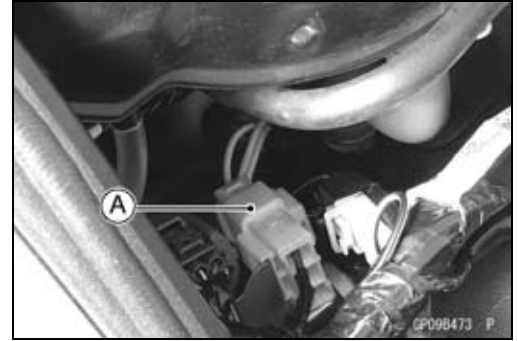

For the Europe Models

- Remove:
 - Bolts [A]
 - Clamp [B]
 - Cover [C]



For the other than Europe Models

- Remove:
 - Bolts [A]
 - Clamp [B]
 - Cover [C]



Alternator Cover Installation

- Apply silicone sealant to the alternator lead grommet and crankcase halves mating surface [A] on the front and rear sides of the cover mount.

Sealant - Kawasaki Bond (Silicone Sealant): 92104-0004

- Check that dowel pins [B] are in place on the crankcase.
- Install a new gasket and the alternator cover.
- Tighten:

Torque - Alternator Cover Bolts: 10 N·m (1.0 kgf·m, 89 in·lb)



Stator Coil Removal

- Remove:
 - Alternator Cover (see Alternator Cover Removal)
 - Holding Plate Bolt [A] and Plate
 - Alternator Lead Grommet [B]
 - Stator Coil Bolts [C]
- Remove the stator coil [D] from the alternator cover.

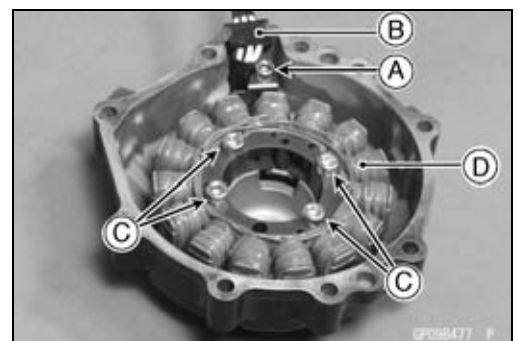

Charging System

Stator Coil Installation

- Tighten the stator coil bolts to the specified torque.
Torque - Stator Coil Bolts: 12 N·m (1.2 kgf·m, 106 in·lb)
- Apply silicone sealant to the circumference of the alternator lead grommet, and fit the grommet into the notch of the cover securely.
Sealant - Kawasaki Bond (Silicone Sealant): 92104-0004
- Secure the alternator lead with a holding plate, and apply a non-permanent locking agent to the thread of the plate bolt and tighten it.
Torque - Alternator Lead Holding Plate Bolt: 10 N·m (1.0 kgf·m, 89 in·lb)
- Install the alternator cover (see Alternator Cover Installation).

Alternator Rotor Removal

- Remove the alternator cover (see Alternator Cover Removal).
- Clean off the oil from the outer circumference of the rotor.
- Hold the alternator rotor steady with the rotor holder [A], and remove the rotor bolt [B] and washer.

Special Tools - Grip [C]: 57001-1591

Rotor Holder (Stopper, M38 × 1.5) [D]: 57001-1658

Rotor Holder: 57001-1666

- Using the flywheel puller [A], remove the alternator rotor from the crankshaft.

Special Tool - Flywheel Puller, M38 × 1.5: 57001-1405

CAUTION

Do not attempt to strike the alternator rotor itself. Striking the rotor can cause the magnets to lose their magnetism.

Alternator Rotor Installation

- Using a cleaning fluid, clean off any oil or dirt on the following portions and dry them with a clean cloth.
 Crankshaft Tapered Portion [A]
 Alternator Rotor Tapered Portion [B]
- Install the alternator rotor.

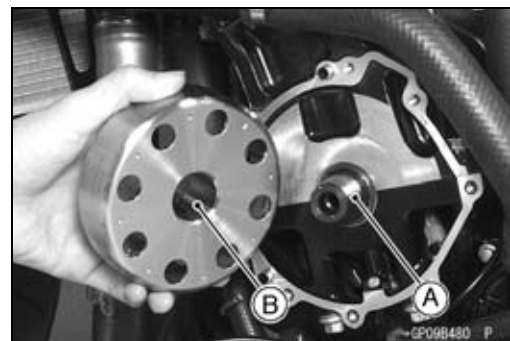
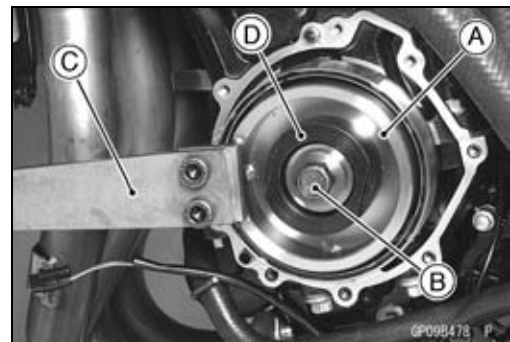

Charging System

- Using a cleaning fluid, clean off any oil or dirt on the washer [A] and dry it with a clean cloth.
- Install the washer.

NOTE

○ Confirm the alternator rotor fit or not to the crankshaft before tightening it with specified torque.

- Install the rotor bolt [B] and tighten it with 70 N·m (7.0 kgf·m, 52 ft·lb) of torque.

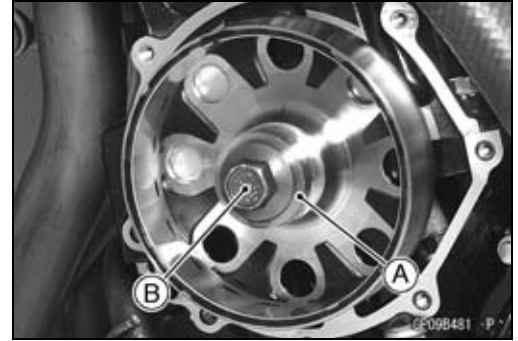

- Remove the rotor bolt and washer.
- Check the tightening torque with flywheel puller [A].
- ★ If the rotor is not pulled out with 20 N·m (2.0 kgf·m, 15 ft·lb) of drawing torque, it is installed correctly.
- ★ If the rotor is pulled out with under 20 N·m (2.0 kgf·m, 15 ft·lb) of drawing torque, clean off any oil dirt or flaw of the crankshaft and rotor tapered portion, and dry them with a clean cloth. Then, confirm that it is not pulled out with above torque.

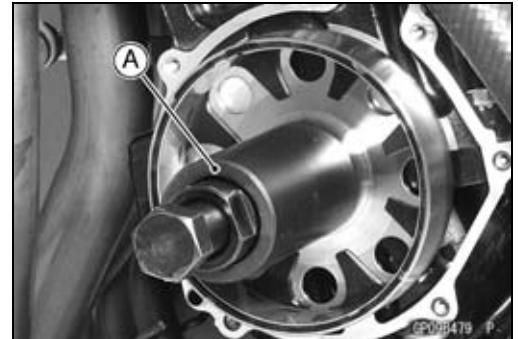

- Install the rotor bolt and washer.
- Tighten the alternator rotor bolt [A] while holding the alternator rotor steadily with the holder [B].

Special Tools - Grip [C]: 57001-1591

Rotor Holder (Stopper, M38 × 1.5) [D]: 57001-1658

Rotor Holder: 57001-1666

Torque - Alternator Rotor Bolt: 155 N·m (15.8 kgf·m, 114 ft·lb)

- Install the alternator cover (see Alternator Cover Installation).

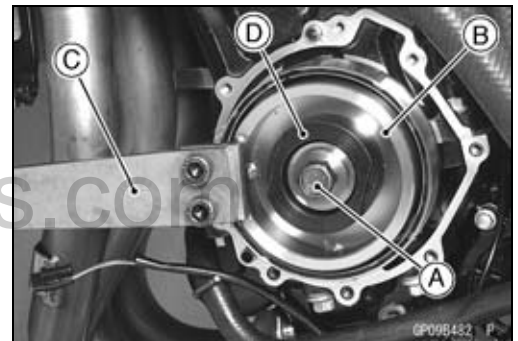

Alternator Inspection

There are three types of alternator failures: short, open (wire burned out), or loss in rotor magnetism. A short or open in one of the coil wires will result in either a low output, or no output at all. A loss in rotor magnetism, which may be caused by dropping or hitting the alternator, by leaving it near an electromagnetic field, or just by aging, will result in low output.

Charging System

- To check the alternator output voltage, do the following procedures.
 - Turn off the ignition switch.
 - Remove the fuel tank (see Fuel Tank Removal in the Fuel System (DFI) chapter).
 - Disconnect the alternator lead connector [A].
 - Connect the hand tester as shown in the table 1.
 - Start the engine.
 - Run it at the rpm given in the table 1.
 - Note the voltage readings (total 3 measurements).

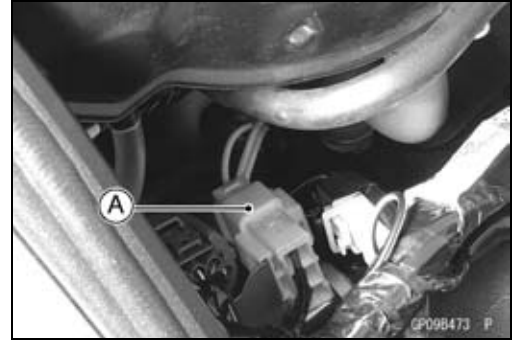

Table 1 Alternator Output Voltage

Tester Range	Connections		Reading @4 000 rpm
	Tester (+) to	Tester (-) to	
250 V AC	One Black lead	Another Black lead	60 V or more

- ★ If the output voltage shows the value in the table, the alternator operates properly.
- ★ If the output voltage shows a much higher than the value in the table, the regulator/rectifier is damaged. A much lower reading than that given in the table indicates that the alternator is defective.
- Check the stator coil resistance as follows.
 - Stop the engine.
 - Connect the commercially available tester as shown in the table 2.
 - Note the readings (total 3 measurement).

Table 2 Stator Coil Resistance

Tester Range	Connections		Reading
	Tester (+) to	Tester (-) to	
× 1 Ω	One Black lead	Another Black lead	0.1 ~ 0.2 Ω

- ★ If there is more resistance than shown in the table, or no tester reading (infinity) for any two leads, the stator has an open lead and must be replaced. Much less than this resistance means the stator is shorted, and must be replaced.
- Using the highest resistance range of the hand tester, measure the resistance between each of the black leads and chassis ground.
- ★ Any hand tester reading less than infinity (∞) indicates a short, necessitating stator replacement.
- ★ If the stator coils have normal resistance, but the voltage check showed the alternator to be defective; then the rotor magnets have probably weakened, and the rotor must be replaced.

Special Tool - Hand Tester: 57001-1394

Charging System

Regulator/Rectifier Inspection

- Remove the Bolts [A].

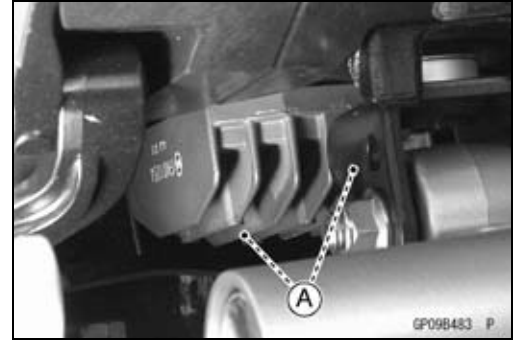

- Disconnect the connectors [A].
- Remove the regulator/rectifier [B].

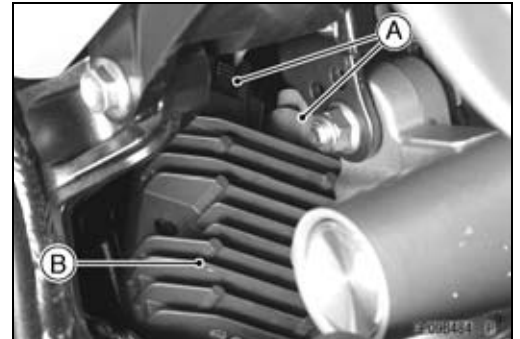

- Set the hand tester to the $\times 1 \text{ k}\Omega$ range and make the measurements shown in the table.

Special Tool - Hand Tester: 57001-1394

- Connect the hand tester to the regulator rectifier.
- ★ If the tester readings are not as specified, replace the regulator/rectifier.

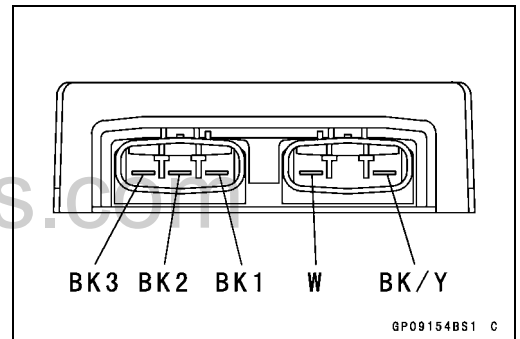

CAUTION

Use only Kawasaki Hand Tester 57001-1394 for this test. A tester other than the Kawasaki Hand Tester may show different readings.
If a megger or a meter with a large capacity battery is used, the regulator/rectifier will be damaged.

Regulator/Rectifier Resistance (Unit: $\text{k}\Omega$)

	Terminal	Tester (+) Lead Connection				
		W	BK1	BK2	BK3	BK/Y
(-)*	W	—	20 ~ 300	20 ~ 300	20 ~ 200	20 ~ 750
	BK1	0 ~ 5	—	20 ~ 300	20 ~ 200	20 ~ 750
	BK2	0 ~ 5	20 ~ 300	—	20 ~ 200	20 ~ 750
	BK3	0 ~ 5	20 ~ 300	20 ~ 300	—	20 ~ 750
	BK/Y	5 ~ 20	5 ~ 20	5 ~ 20	5 ~ 20	—

(-)*: Tester (-) Lead Connection

- Install the regulator/rectifier.

Torque - Regulator/Rectifier Bolts: 10 N·m (1.0 kgf·m, 89 ft·lb)

Charging System

Charging Voltage Inspection

- Check the battery condition (see Charging Condition Inspection).
- Warm up the engine to obtain actual alternator operating conditions.
- Remove the Front seat (see Front Seat Removal in the Frame chapter).
- Check that the ignition switch is turned off, and connect the hand tester [A] to the battery terminals [B].

Special Tool - Hand Tester: 57001-1394

- Start the engine, and note the voltage readings at various engine speeds with the headlight turned on and then turned off (To turn off the headlight, disconnect the headlight connector on the headlight unit.). The readings should show nearly battery voltage when the engine speed is low, and, as the engine speed rises, the readings should also rise. But they must be kept under the specified voltage.

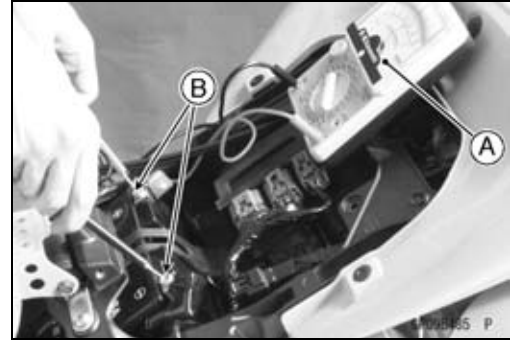

Charging Voltage

Tester Range	Connections		Reading
	Tester (+) to	Tester (-) to	
25 V DC	Battery (+)	Battery (-)	14.2 ~ 15.2 V

- Turn off the ignition switch to stop the engine, and disconnect the hand tester.
- ★ If the charging voltage is kept between the values given in the table, the charging system is considered to be working normally.
- ★ If the charging voltage is much higher than the values specified in the table, the regulator/rectifier is defective or the regulator/rectifier leads are loose or open.
- ★ If the charging voltage does not rise as the engine speed increases, then the regulator/rectifier is defective or the alternator output is insufficient for the loads. Check the alternator and regulator/rectifier to determine which part is defective.

Charging System

Charging System Circuit

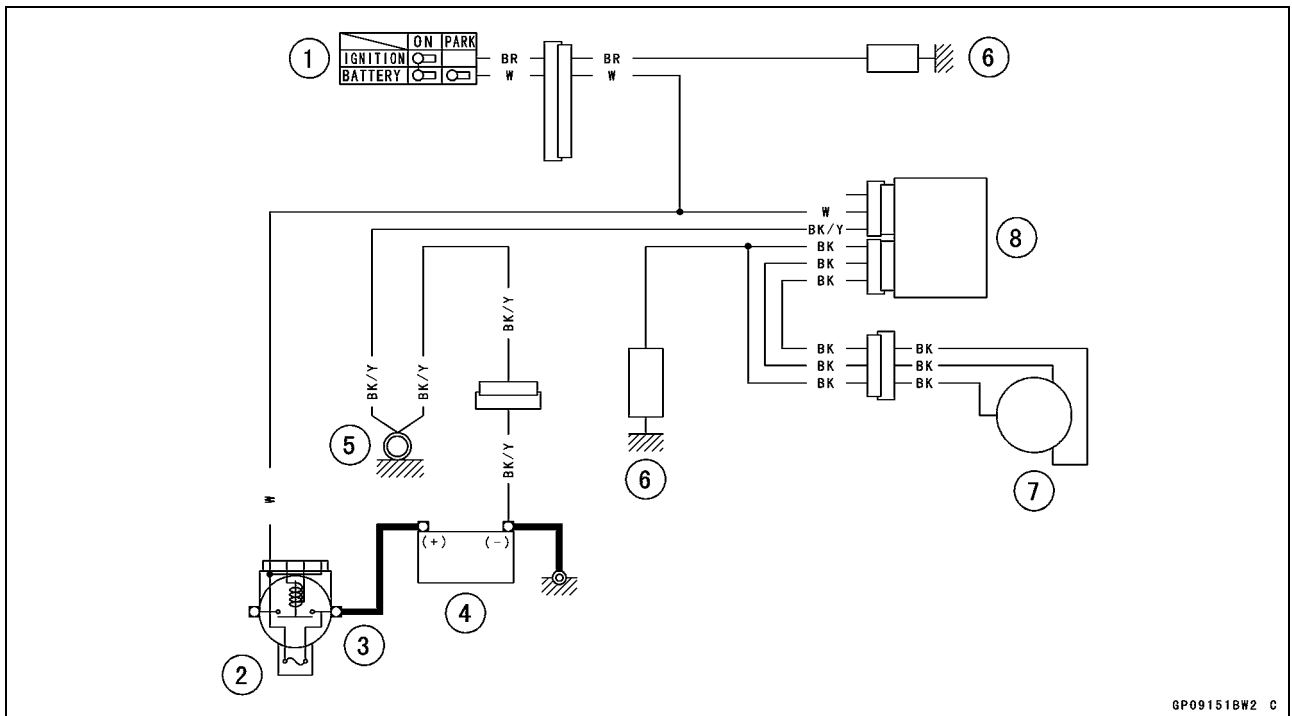

- 1. Ignition Switch
- 2. Main Fuse 30 A
- 3. Starter Relay
- 4. Battery 12 V 10 Ah
- 5. Frame Ground
- 6. Load
- 7. Alternator
- 8. Regulator/Rectifier

Ignition System

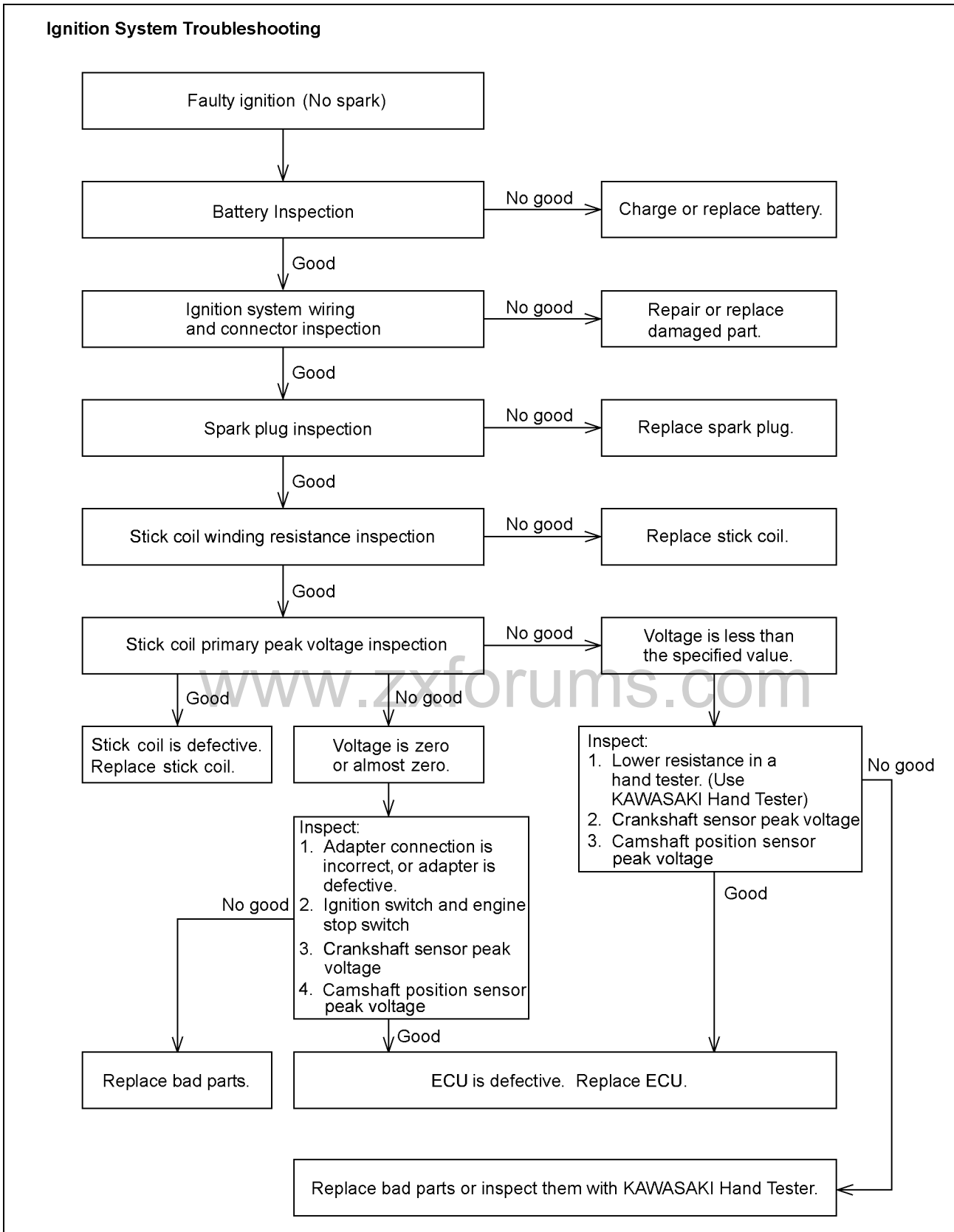

Ignition System

⚠ WARNING

The ignition system produces extremely high voltage. Do not touch the spark plugs or stick coils while the engine is running, or you could receive a severe electrical shock.

CAUTION

Do not disconnect the battery cables or any other electrical connections when the ignition switch is on, or while the engine is running. This is to prevent ECU damage.

Do not install the battery backwards. The negative side is grounded. This is to prevent damage to the ECU.

Crankshaft Sensor Removal

- Remove:
 - Fuel Tank (see Fuel Tank Removal in the Fuel System (DFI) chapter)
 - Crankshaft Sensor Lead Connector [A]



- Remove:
 - Starter Clutch Cover (see Starter Clutch Removal)
 - Starter Idle Gear (see Starter Idle Gear Removal)
 - Bolts [A]
 - Crankshaft Sensor [B]



Crankshaft Sensor Installation

- Apply a non-permanent locking agent to the threads of the crankshaft sensor bolts [A], and tighten it.
 - Torque - Crankshaft Sensor Bolts: 6.0 N·m (0.61 kgf·m, 53 in·lb)**
- Apply silicone sealant to the circumference of the crankshaft sensor lead grommet [B], and fit the grommet into the notch of the crankcase securely.
 - Sealant - Kawasaki Bond (Silicone Sealant): 92104-0004**
- Install the starter clutch cover (see Starter Clutch Installation).
- Route the crankshaft sensor lead correctly (see Cable, Wire, and Hose Routing section in the Appendix chapter).
- Install the removed parts (see appropriate chapters).



Ignition System

Crankshaft Sensor Inspection

- Disconnect the crankshaft sensor lead connector (see Crankshaft Sensor Removal).
- Set the hand tester [A] to the $\times 100 \Omega$ range and connect it to the crankshaft sensor lead connector [B].

Special Tool - Hand Tester: 57001-1394

Crankshaft Sensor Resistance: 380 ~ 570 Ω

- ★ If there is more resistance than the specified value, the coil has an open lead and must be replaced. Much less than this resistance means the coil is shorted, and must be replaced.
- Using the highest resistance range of the tester, measure the resistance between the crankshaft sensor leads and chassis ground.
- ★ Any tester reading less than infinity (∞) indicates a short, necessitating replacement of the crankshaft sensor.

Crankshaft Sensor Peak Voltage Inspection

NOTE

- Be sure the battery is fully charged.
- Using the peak voltage adapter is a more reliable way to determine the condition of the crankshaft sensor than crankshaft sensor internal resistance measurements.

- Disconnect the crankshaft sensor lead connector (see Crankshaft Sensor Removal).
- Set the hand tester [A] to the $\times 25 \text{ V DC}$ range, and connect the peak voltage adapter [B].

Special Tools - Hand Tester: 57001-1394

Peak Voltage Adapter: 57001-1415

Type: KEK-54-9-B

- Connect the black lead (-) [C] of the adapter to yellow lead and red lead (+) [D] to black lead in the crankshaft sensor connector [E].
- Turn the ignition switch and engine stop switch ON.
- Pushing the starter button, turn the engine 4 ~ 5 seconds with the transmission gear in neutral to measure the crankshaft sensor peak voltage.
- Repeat the measurement 5 or more times.

Crankshaft Sensor Peak Voltage

Standard: 3.2 V or more

- ★ If the tester reading is not specified one, check the crankshaft sensor.

Stick Coil (Ignition Coil together with Spark Plug Cap) Removal

- Remove:
 - Fuel Tank (see Fuel Tank Removal in the Fuel System (DFI) chapter)
 - Air Cleaner Housing (see Air Cleaner Housing Removal in the Fuel System (DFI) chapter)

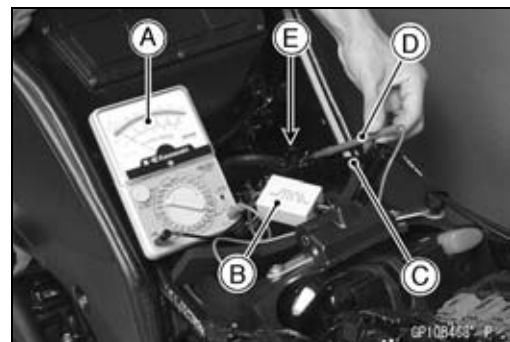
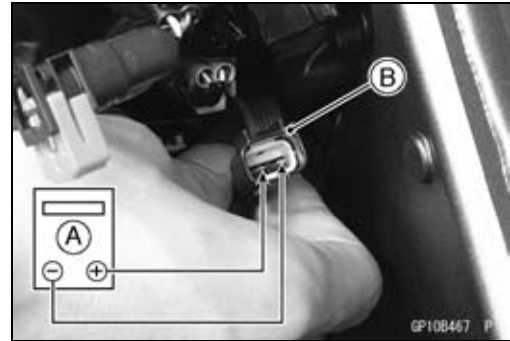

Ignition System

- Disconnect the stick coil connectors [A].
- Pull the stick coils #2, #3 [B] off the spark plugs.

CAUTION

Do not pry the connector part of the coil while removing the coil.

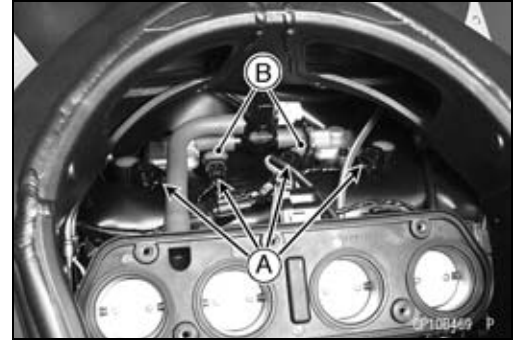

- For remove the stick coil #1 as follows.

○Remove:

Left Middle Fairing (see Middle Fairing Removal in the Frame chapter)

Harness Joint Connector [A]

Camshaft Position Sensor Lead Connector [B]

Immobilizer Amplifier Connector (Immobilizer Models)

Left Upper Inner Fairing Bracket Bolts [C]

Left Upper Inner Fairing Bracket [D]

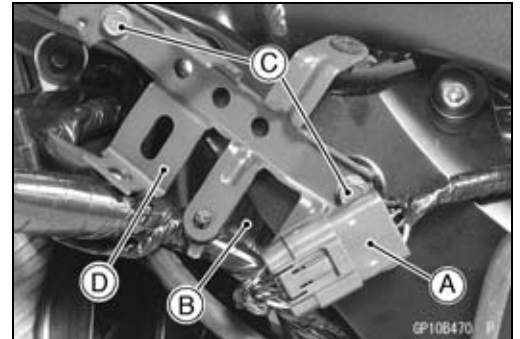

○Remove:

Coolant Reserve Tank (see Coolant Reserve Tank Removal in the Cooling System chapter)

Left Engine Bracket Bolts [A]

Left Engine Bracket [B]

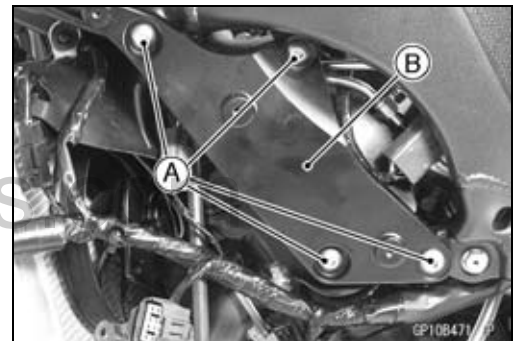

- Pull out the stick coil #1 [A] to forward.



- For remove the stick coil #4 as follows.

○Remove:

Right Middle Fairing (see Middle Fairing Removal in the Frame chapter)

Right Upper Inner Fairing Bracket Bolts [A]

Right Upper Inner Fairing Bracket [B]

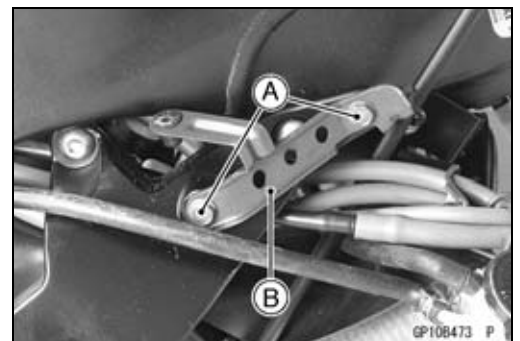

Ignition System

○Remove:

- Right Engine Bracket Bolts [A]
- Right Engine Bracket [B]

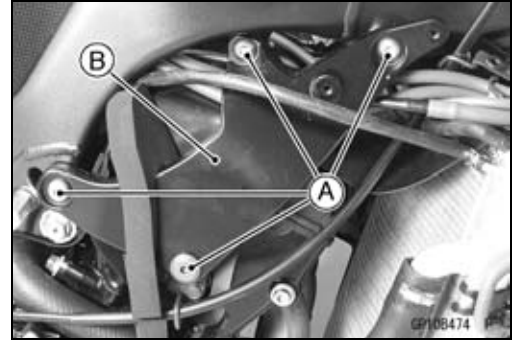

○Pull out the stick coil #4 [A] to forward.



Stick Coil (Ignition Coil together with Spark Plug Cap) Installation

- Apply grease to the stick coils.
- Insert the stick coils [A] as shown being careful of the coil heads directions.
- Align the lines [B] of the cylinder head cover and coil heads.

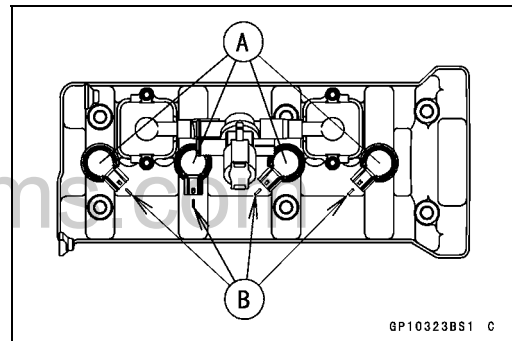

CAUTION

Do not tap the coil head while installing the coil.

- Connect the stick coil connectors.
- Run the hoses and harness correctly (see Cable, Wire, and Hose Routing section in Appendix chapter).
- Install the left and right engine bracket (see Engine Installation in the Engine Removal/Installation chapter).
- Install the removed parts (see appropriate chapters).

Ignition System

Stick Coil (Ignition Coil together with Spark Plug Cap) Inspection

- Remove the stick coils (see Stick Coil (Ignition Coil together with Spark Plug Cap) Removal).
- Measure the primary winding resistance [A] as follows.
 - Connect the hand tester between the coil terminals.
 - Set the tester to the $\times 1 \Omega$ range, and read the tester.
- Measure the secondary winding resistance [B] as follows.
 - Connect the tester between the plug terminal and (-) coil terminal.
 - Set the tester to the $\times 1 \text{ k}\Omega$ range and read the tester.

Ignition Coil Winding Resistance

Primary Windings: 1.2 ~ 1.6 Ω

Secondary Windings: 8.5 ~ 11.5 $\text{k}\Omega$

- ★ If the tester does not read as specified, replace the coil.

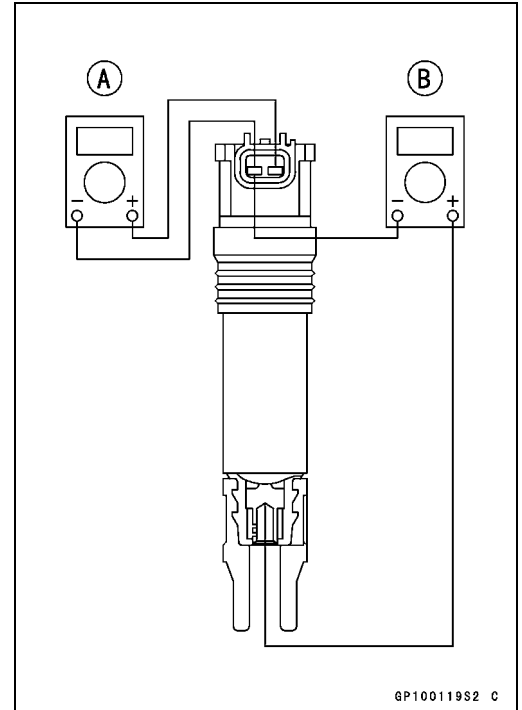

Stick Coil Primary Peak Voltage

NOTE

- Be sure the battery is fully charged.

- Remove the stick coils (see Stick Coil (Ignition Coil together with Spark Plug Cap) Removal).
- Do not remove the spark plug.
- Measure the primary peak voltage as follows.
 - Install the new spark plug [A] into each stick coil [B], and ground them onto the engine.
 - Connect the peak voltage adapter [C] into the hand tester [D] which is set to the $\times 250 \text{ V DC}$ range.
 - Connect the adapter to the lead wire-peak voltage adapter [E] which is connected between the stick coil connector and stick coil.

ECU [F]

Special Tools - Hand Tester: 57001-1394

Peak Voltage Adapter: 57001-1415

Type: KEK-54-9-B

Lead Wire-Peak Voltage Adapter: 57001-1449

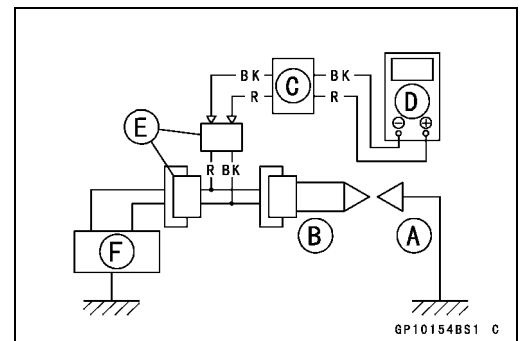
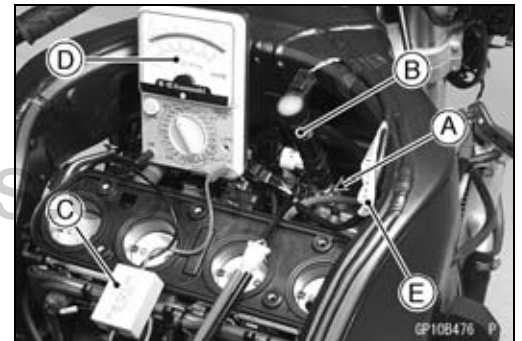

Primary Lead Connection

Adapter (R, +) to lead wire-peak voltage adapter (BK)

Adapter (BK, -) to lead wire-peak voltage adapter (R)

Ignition System

⚠ WARNING

To avoid extremely high voltage shocks, do not touch the spark plugs or tester connections.

- Turn the ignition switch and engine stop switch ON.
- Pushing the starter button, turn the engine 4 ~ 5 seconds with the transmission in neutral to measure the primary peak voltage.
- Repeat the measurements 5 times for one stick coil.

Stick Coil Primary Peak Voltage

Standard: 72 V or more

- Repeat the test for the other stick coils.
- ★ If the reading is less than the specified value, check the following.
 - Stick Coils (see Stick Coil (Ignition Coil together with Spark Plug Cap) Inspection)
 - Crankshaft Sensor (see Crankshaft Sensor Inspection)
 - ECU (see ECU Power Supply Inspection in the Fuel System (DFI) chapter)

Spark Plug Removal

- Refer to the Spark Plug Replacement in the Periodic Maintenance chapter (see Spark Plug Replacement in the Periodic Maintenance chapter).

Spark Plug Installation

- Refer to the Spark Plug Replacement in the Periodic Maintenance chapter (see Spark Plug Replacement in the Periodic Maintenance chapter).

Spark Plug Condition Inspection

- Visually inspect the spark plugs.
- ★ If the spark plug center electrode [A] and/or side electrode [B] are corroded or damaged, or if the insulator [C] is cracked, replace the plug.
- ★ If the spark plug is dirtied or the carbon is accumulated, replace the spark plug.
- Measure the gap [D] with a wire-type thickness gauge.
- ★ If the gap is incorrect, replace the spark plug.

Spark Plug Gap: 0.8 ~ 0.9 mm (0.032 ~ 0.035 in.)

- Use the standard spark plug or its equivalent.

Spark Plug: CR9EIA-9

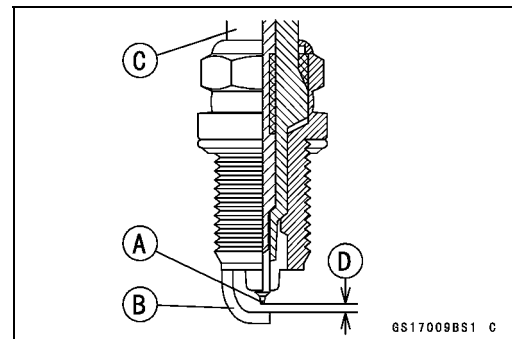

Ignition System

Camshaft Position Sensor Removal

- Remove:
 - Fuel Tank (see Fuel Tank Removal in the Fuel System (DFI) chapter)
 - Air Cleaner Housing (see Air Cleaner Housing Removal in the Fuel System (DFI) chapter)
- Disconnect the camshaft position sensor lead connector [A].

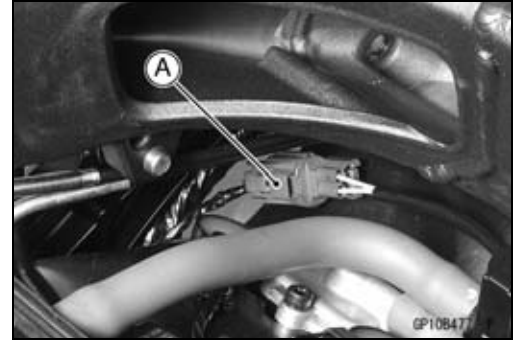

- Remove:
 - Right Middle Fairing (see Middle Fairing Removal in the Frame chapter)
 - Camshaft Position Sensor Bolt [A]
 - Camshaft Position Sensor [B]

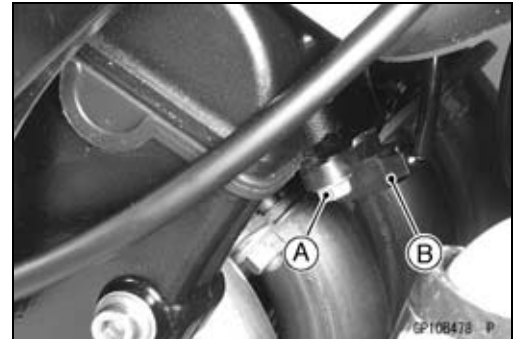

Camshaft Position Sensor Installation

- Replace the O-ring of the camshaft position sensor.
- Apply grease to the new O-ring.
- Tighten:
 - Torque - Camshaft Position Sensor Bolt: 10 N·m (1.0 kgf·m, 89 in·lb)**
- Route the camshaft position sensor lead correctly (see Cable, Wire, and Hose Routing section in the Appendix chapter).

Camshaft Position Sensor Inspection

- Disconnect the camshaft position sensor lead connector (see Camshaft Position Sensor Removal).
- Set the hand tester to the $\times 10 \Omega$ range and connect it to the terminals.

Special Tool - Hand Tester: 57001-1394

Camshaft Position Sensor Resistance: 400 ~ 460 Ω

- ★ If there is more resistance than the specified value, the sensor coil has an open lead and must be replaced. Much less than this resistance means the sensor coil is shorted, and must be replaced.
- Using the highest resistance range of the tester, measure the resistance between the camshaft position sensor leads and chassis ground.
- ★ Any tester reading less than infinity (∞) indicates a short, necessitating replacement of the camshaft position sensor.

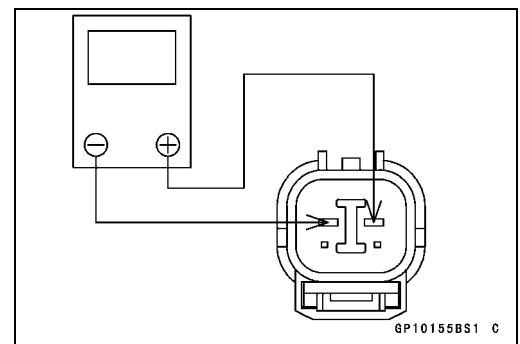

Ignition System

Camshaft Position Sensor Peak Voltage Inspection

- Disconnect the camshaft position sensor connector (see Camshaft Position Sensor Removal).
- Set the hand tester [A] to the 10 V DC range.
- Connect the peak voltage adapter [B] to the hand tester and camshaft position sensor leads in the terminals.

Special Tool - Hand Tester: 57001-1394
Peak Voltage Adapter: 57001-1415
Type: KEK-54-9-B

Connections:

Camshaft Position Sensor Terminal		Adapter		Hand Tester
White/Yellow [C]	←	Red	→	(+)
Yellow [D]	←	Black	→	(-)

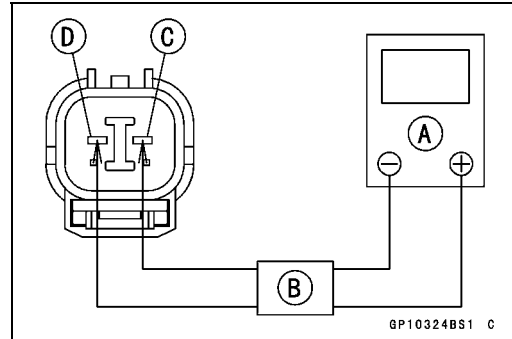
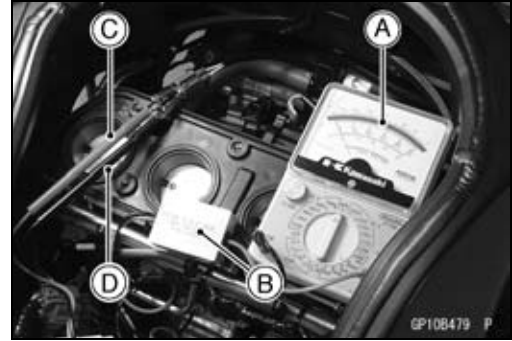

- Turn the ignition switch and engine stop switch ON.
- Pushing the starter button, turn the engine 4 ~ 5 seconds with the transmission gear in neutral to measure the camshaft position sensor peak voltage.
- Repeat the measurement 5 or more times.

Camshaft Position Sensor Peak Voltage
Standard: 0.4 V or more

★ If the peak voltage is lower than the standard, inspect the camshaft position sensor.

Interlock Operation Inspection

- Using the stand [A], raise the rear wheel off the ground.

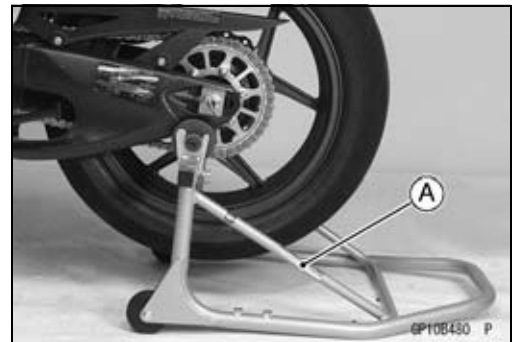

1st Check

- Start the engine to the following conditions.

Condition:

- Transmission Gear** → 1st Position
- Clutch Lever** → Release
- Sidestand** → Down or Up

- Turn the ignition switch ON and push the starter button.
- Then the starter motor should not turn when the starter system circuit is normality.
- ★ If the engine is start, inspect the starter lockout switch, gear position switch, and relay box.
- ★ If their parts are normality replace the ECU.

Ignition System

2nd Check

- Start the engine to the following conditions.

Condition:

Transmission Gear → 1st Position

Clutch Lever → Pulled in

Sidestand → Up

- Turn the ignition switch ON and push the starter button.
- Then the starter motor should turn when the starter system circuit is normality.
- ★ If the starter motor is not turn, inspect the starter lockout switch, gear position switch, sidestand switch and relay box.
- ★ If their parts are normality replace the ECU.

3rd Check

- Inspect the engine for its secure stop after the following operations are completed.
- Run the engine to the following conditions.

Condition:

Transmission Gear → 1st Position

Clutch Lever → Release

Sidestand → Up

- Set the side stand on the ground, then the engine will stop.
- ★ If whichever may not be stopped, inspect the gear position switch, starter lockout switch, sidestand switch and relay box.
- ★ If their parts are normality, replace the ECU.

IC Igniter Inspection

- The IC igniter is built in the ECU [A].
- Refer to the Interlock Operation Inspection, Ignition System Troubleshooting chart and Fuel System (DFI) chapter for ECU Power Supply Inspection (see Interlock Operation Inspection, Ignition System Troubleshooting chart and Fuel System (DFI) chapter for ECU Power Supply Inspection).

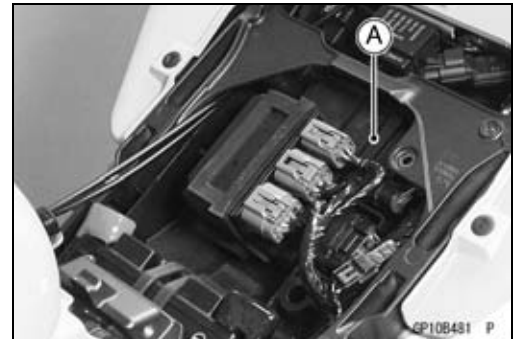

Ignition System

Ignition System Circuit

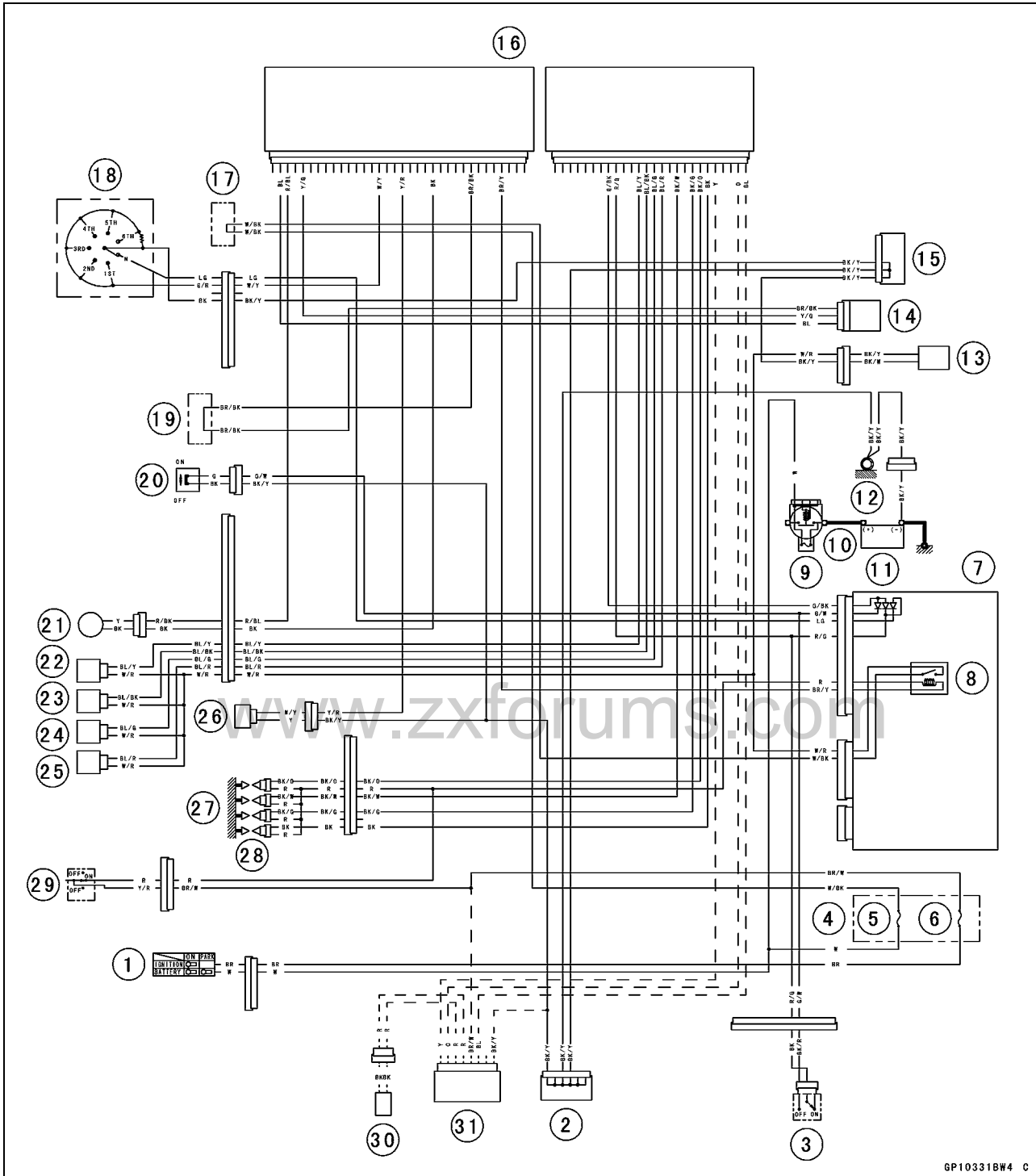

GP10331B#4 C

- | | | |
|---------------------------|--------------------------|---|
| 1. Ignition Switch | 12. Frame Ground | 23. Fuel Injector #3 |
| 2. Joint Connector 1 | 13. Fuel Pump | 24. Fuel Injector #2 |
| 3. Starter Lockout Switch | 14. Vehicle-down Sensor | 25. Main Fuse 30 A |
| 4. Fuse Box | 15. Joint Connector 2 | 26. Camshaft Position Sensor |
| 5. ECU Fuse 15 A | 16. ECU | 27. Spark Plugs |
| 6. Ignition Fuse 15 A | 17. Water-proof Joint 1 | 28. Stick Coils |
| 7. Relay Box | 18. Gear Position Switch | 29. Engine Stop Switch |
| 8. Fuel Pump Relay | 19. Water-proof Joint 2 | 30. Immobilizer Antenna
(Immobilizer Models) |
| 9. Main Fuse 30 A | 20. Sidestand Switch | 31. Immobilizer Amplifier
(Immobilizer Models) |
| 10. Starter Relay | 21. Crankshaft Sensor | |
| 11. Battery 12 V 10 Ah | 22. Fuel Injector #4 | |

Electric Starter System

Starter Idle Gear Removal

- Remove:
 - Right Middle Fairing (see Right Middle Fairing Removal in the Frame chapter)
 - Bolts [A]
 - Idle Gear Cover [B]

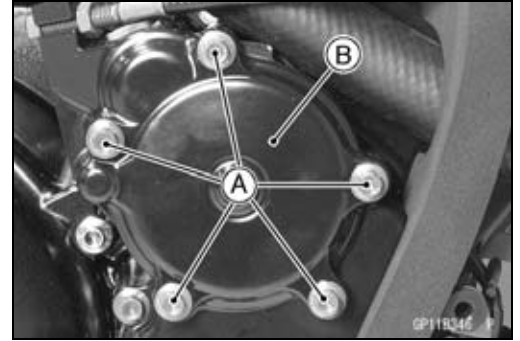

- Pull out the idle gear (starter motor side) [A] with the shaft [B].

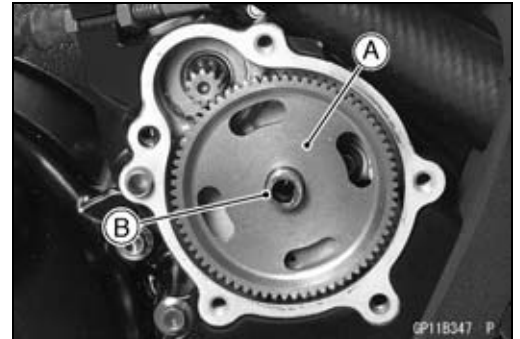

- Remove:
 - Clutch Cable Lower End (see Cable Removal in the Clutch chapter)
 - Bolts [A]
 - Clamp [B]
 - Starter Clutch Cover [C]

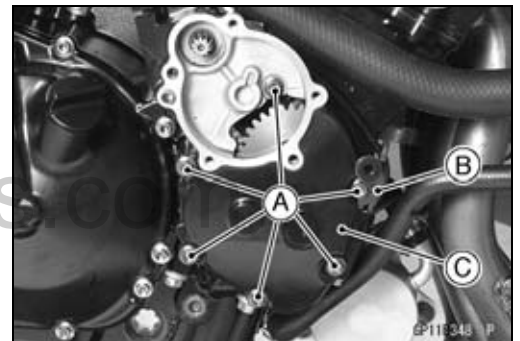

- Pull out the idle gear (starter clutch side) [A] with the shaft [B].

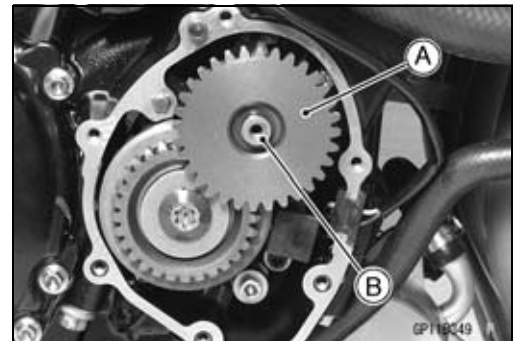

Starter Idle Gear Installation

- Apply molybdenum disulfide grease [A] to the idle gear shaft (starter clutch side) [B].
- Fit the pin [C] into the groove [D] of the crankcase.

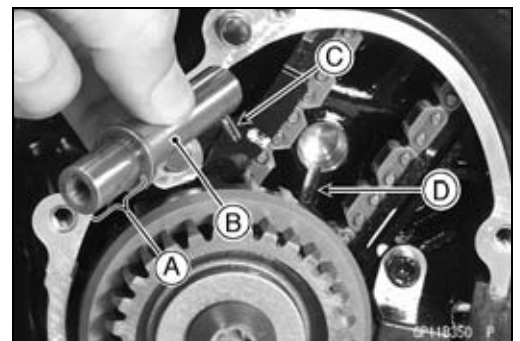

Electric Starter System

- Install the idle gear (starter clutch side) [A] on the shaft.
- Engage the idle gear with the starter clutch gear.
- Apply silicone sealant to the following portion.
Crankshaft Sensor Lead Grommet [B]
Crankcase Halves Mating Surfaces [C]

Sealant - Kawasaki Bond (Silicone Sealant): 92104-0004

- Install the dowel pin [D] and new gasket.

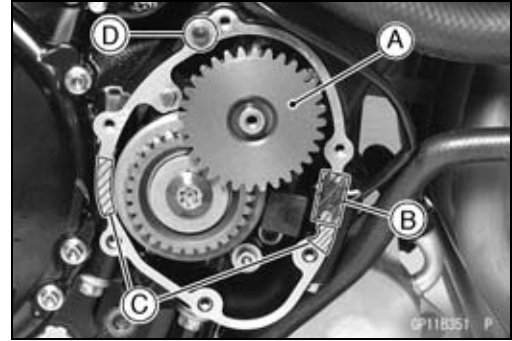

- Apply grease to the O-rings of starter motor.

- Install:
Starter Clutch Cover [A]
Clamp [B]

- Tighten:

Torque - Starter Clutch Cover Bolts: 10 N·m (1.0 kgf·m, 89 in·lb)

L = 20 mm (0.79 in.) [C]

L = 30 mm (1.18 in.) [D]

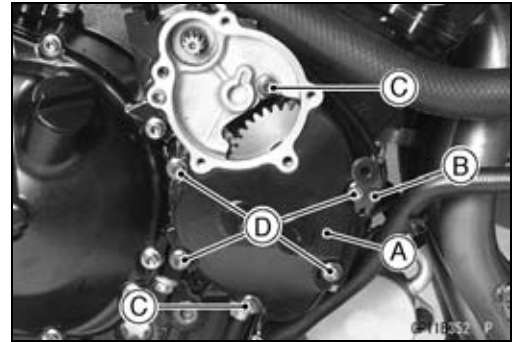

- Apply molybdenum disulfide grease [A] to the idle gear shaft (starter motor side) [B].

- Fit the pin [C] into the groove [D] of the starter clutch cover.

www.zxforums.com

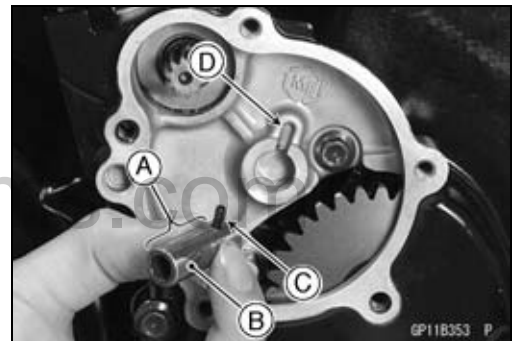

- Install the idle gear (starter motor side) [A] on the shaft.
- Engage the idle gear with the starter motor gear and idle gear (starter clutch side).
- Install the dowel pin [B] and new gasket.



- Install:
Idle Gear Cover [A]
Idle Gear Cover Bolts [B]
Idle Gear Cover Bolt [C] with Gasket.

- Tighten:

Torque - Idle Gear Cover Bolts: 10 N·m (1.0 kgf·m, 89 in·lb)

- Install the removed parts (see appropriate chapters).

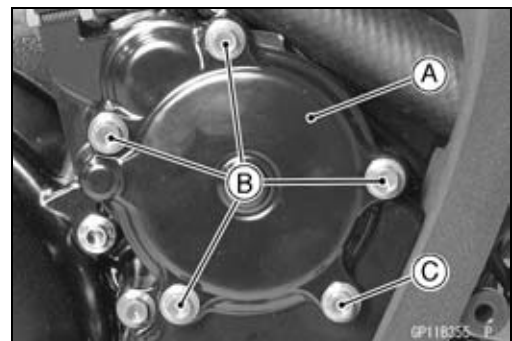

Electric Starter System

Starter Clutch Removal

- Remove:
 - Starter Clutch Cover (see Idle Gear Removal)
 - Idle Gear (Starter Clutch Side, see Idle Gear Removal)
- Unscrew the starter clutch bot [A], while holding the alternator rotor steady with the rotor holder (see Alternator Rotor Removal).

Special Tools - Grip: 57001-1591

Rotor Holder (Stopper, M38 × 1.5): 57001-1658

Rotor Holder: 57001-1666

- Remove the washer [B].
- Pull the starter clutch gear [A] out of the starter clutch [B].
- Remove:
 - Needle Bearing [C]
 - Starter Clutch

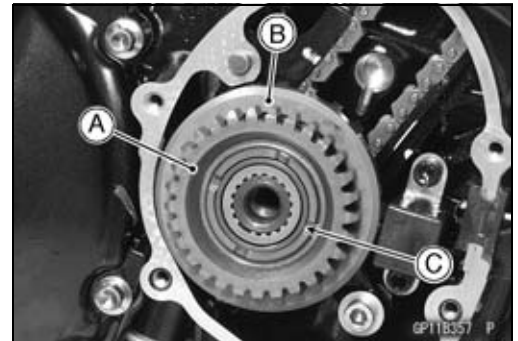
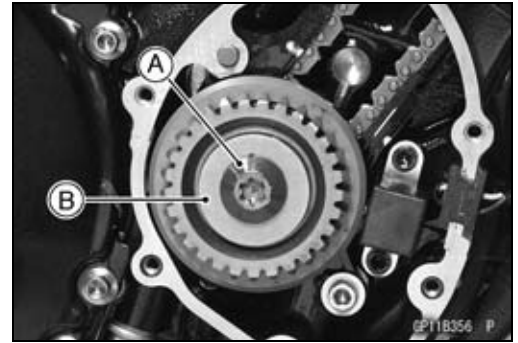

Starter Clutch Installation

- Install the starter clutch [A] while fitting the alignment notch [B] of the splines onto the alignment tooth [C].

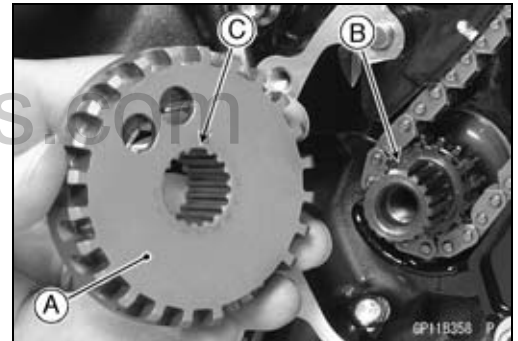

- Apply molybdenum disulfide oil solution to the needle bearing [A], and install it.

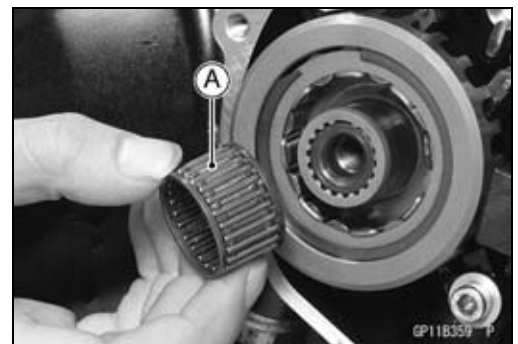

Electric Starter System

- Push [A] the starter clutch gear [B] in and turn it counter-clockwise [C] and install it.



- Install the washer [A].
- Tighten the starter clutch bolt [B], while holding the alternator rotor steady with the rotor holder (see Alternator Rotor Installation).

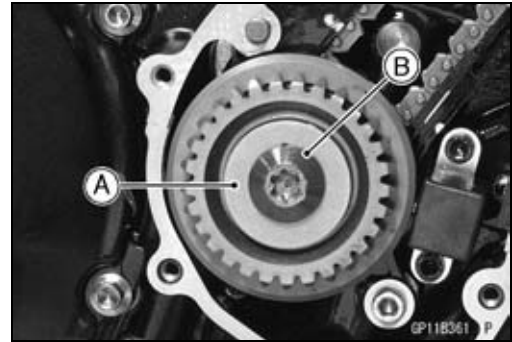

Special Tools - Grip: 57001-1591
Rotor Holder (Stopper, M38 x 1.5): 57001-1658
Rotor Holder: 57001-1666

Torque - Starter Clutch Bolt: 49 N·m (5.0 kgf·m, 36 ft·lb)

- Install the removed parts (see appropriate chapters).

Starter Clutch Disassembly

- Remove:
 Starter Clutch (see Starter Clutch Removal)
 Snap Ring [A]
- Pull the one-way clutch [B] out of the starter clutch case [C].

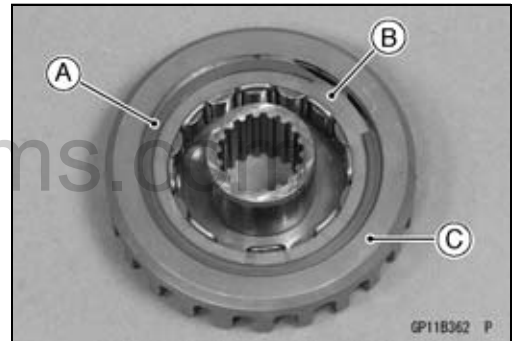

Starter Clutch Assembly

- Install the one-way clutch [A] so that its circlip side [B] faces in.
- Install the new snap ring.

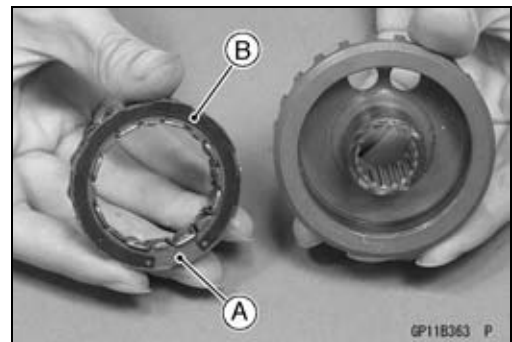

Starter Clutch Inspection

- Remove:
 Starter Clutch Cover (see Idle Gear Removal)
 Idle Gear (Starter clutch side, see Idle Gear Removal)
- Turn the starter clutch gear [A] by hand. The starter clutch gear should turn counterclockwise freely [B], but should not turn clockwise.
- ★ If the starter clutch does not operate as it should or if it makes noise, go to the next step.

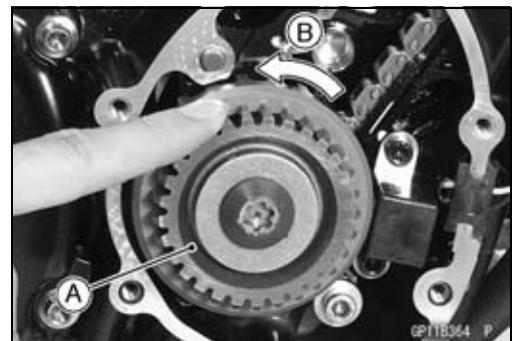

Electric Starter System

- Disassemble the starter clutch (see Starter Clutch Disassembly), and visually inspect the clutch parts.
 - One-way Clutch [A]
 - Starter Clutch Case [B]
- ★ If there is any worn or damaged part, replace it.

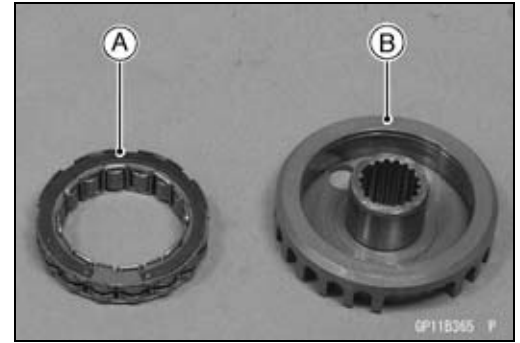

- Examine the starter clutch gear [C] as well. Replace the clutch gear if it is worn or damaged.

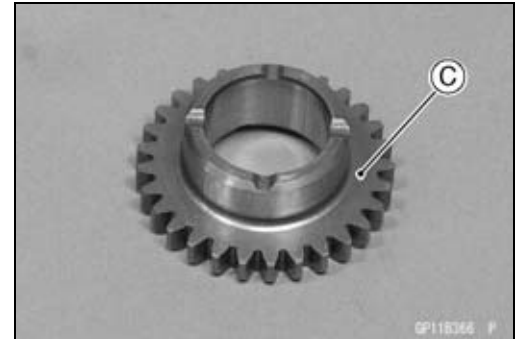

Starter Motor Removal

- Remove:
 - Fuel Tank (see Fuel Tank Removal in the Fuel System (DFI) chapter)
 - Air Cleaner Housing (see Air Cleaner Housing Removal in the Fuel System (DFI) chapter)
 - Throttle Body Assy (see Throttle Body Assy Removal in the Fuel System (DFI) chapter)
- Drain the coolant (see Coolant Change in the Periodic Maintenance chapter).
- Remove the water hose [A].



- Remove the starter clutch cover (see Starter Idle Gear Removal).
- Slide out the rubber cap [A].
- Remove the starter motor cable terminal nut [B].

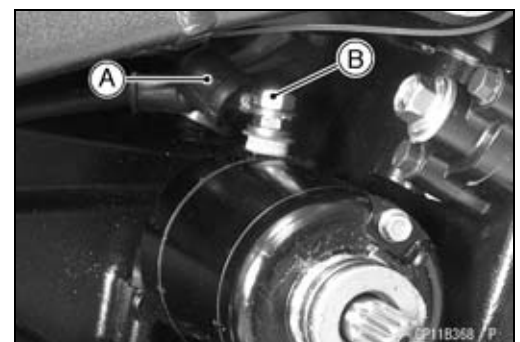

Electric Starter System

- Remove the starter motor mounting bolts [A].
- Pull out the starter motor from the right side.

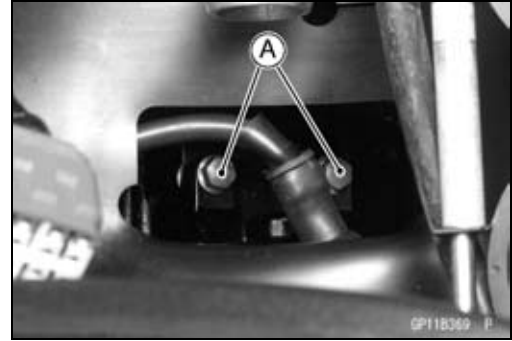

Starter Motor Installation

CAUTION
Do not tap the starter motor shaft or body. Tapping the shaft or body could damage the motor.

- Clean the starter motor legs [A] and crankcase [B] where the starter motor is ground.

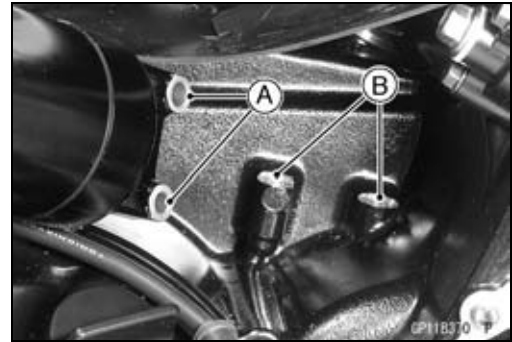

- Replace the O-rings [A] with new ones.
- Apply grease to the new O-rings.
- Set the starter motor mounting bolts [B].
- Temporary tighten the starter motor mounting bolts.
- Install the starter clutch cover (see Idle Shaft Installation).
- Tighten:
 - Torque - Starter Motor Mounting Bolts: 10 N·m (1.0 kgf·m, 89 in·lb)**

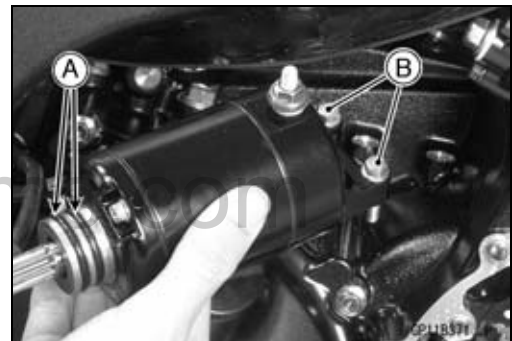

- Position the starter motor cable [A] as shown.
 - About 45° [B]
 - Front [C]
- Tighten:
 - Torque - Starter Motor Cable Terminal Nut: 6.0 N·m (0.61 kgf·m, 53 in·lb)**
- Slide back the rubber cap to the original position.

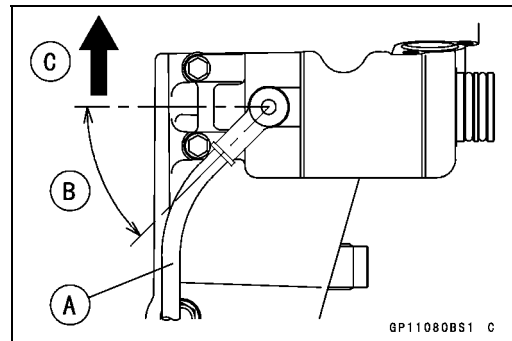

Starter Motor Disassembly

- Remove the starter motor (see Starter Motor Removal).
- Take off the starter motor through bolts [A] and remove both end covers [B].

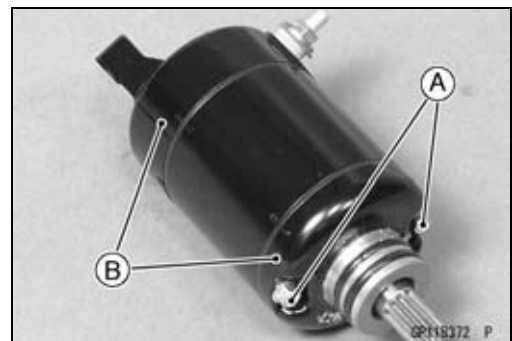

Electric Starter System

- Pull the armature [A] out of the yoke [B].

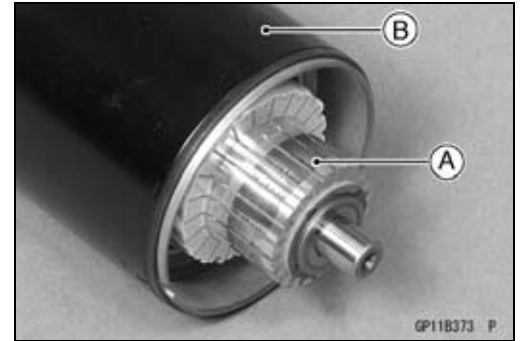

- Remove:
 - Brush Plate Terminal Nut [A]
 - Brush Plate Assembly [B]



Starter Motor Assembly

- Pry the spring end [A] and insert the brush [B].

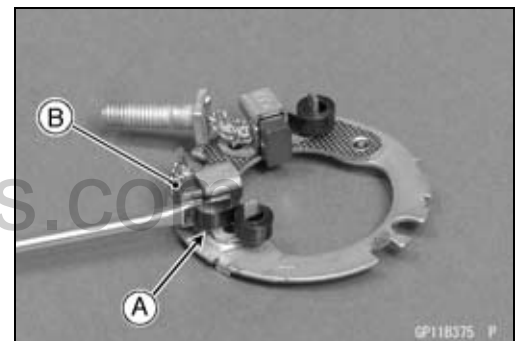

- Install the brush plate assembly [A] into the right-hand end cover [B].
- Replace the O-ring [C] with a new one.
- Install:
 - Insulators [D]
 - Washer [E]
- Tighten:
 - Torque - Starter Motor Terminal Locknut [F]: 6.9 N·m (0.70 kgf·m, 61 in·lb)**

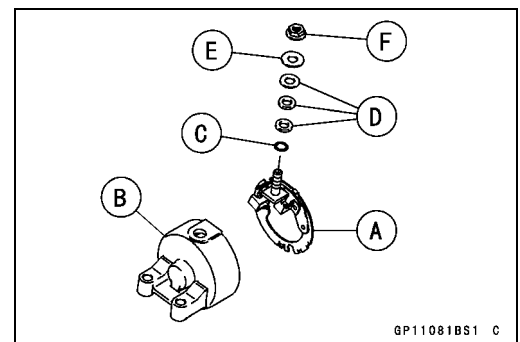

- Install the armature [A] into the yoke [B].
- Install the slip [C] and thrust washers [D] onto each side of the shaft.

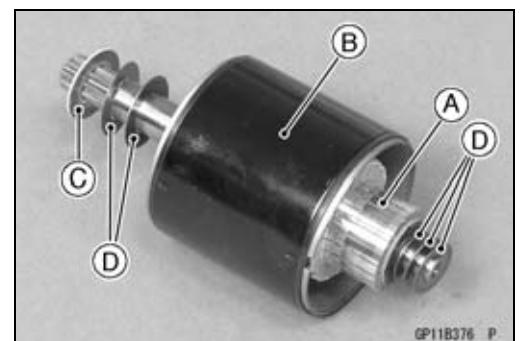

Electric Starter System

- Replace the O-rings [A] with new ones.
- Put the armature [B] among the brushes [C].

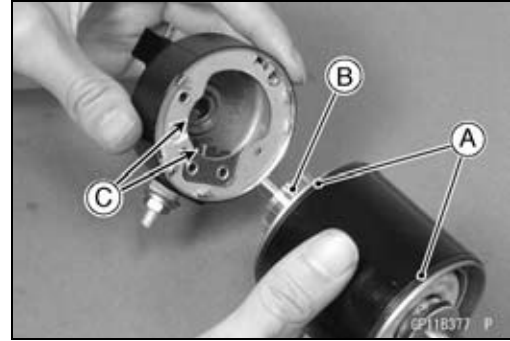

- Apply a thin coat of grease to the oil seal [A].
- Fit the toothed washer [B] into the left-hand end cover.

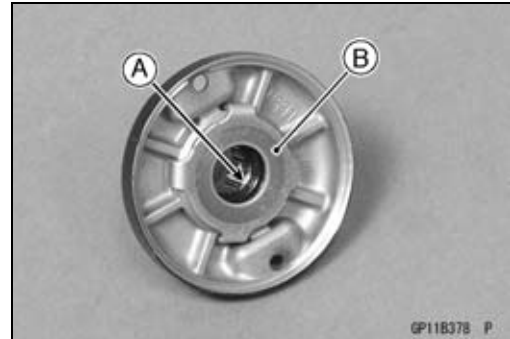

- Align the marks [A] to assembly the yoke and the end covers.

www.zxforums.com

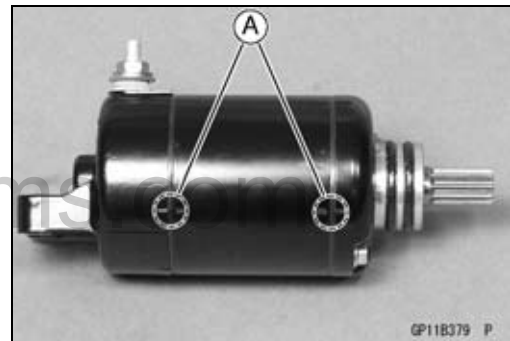

- Replace the O-rings [A] with new ones.
- Tighten:
Torque - Starter Motor Through Bolts [B]: 3.4 N·m (0.35 kgf·m, 30 in·lb)

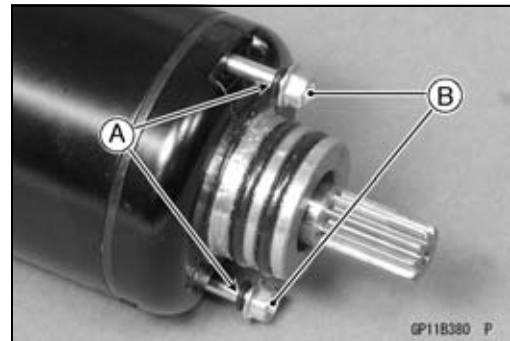

- Replace the O-rings [A] with new ones.
- Apply grease to the new O-rings.



Electric Starter System

Brush Inspection

- Measure the length [A] of each brush [B].
- ★ If any is worn down to the service limit, replace the brush holder assembly.

Starter Motor Brush Length

Standard: 10 mm (0.39 in.)

Service Limit: 5.0 mm (0.20 in.)

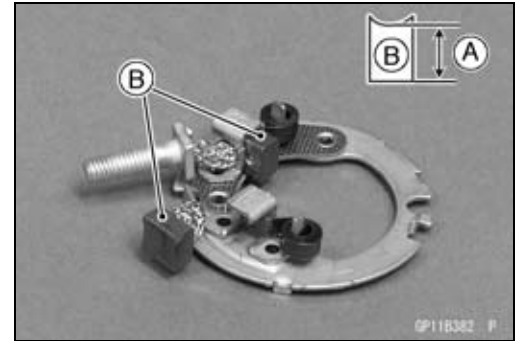

Commutator Cleaning and Inspection

- Smooth the commutator surface [A] if necessary with fine emery cloth [B], and clean out the grooves.

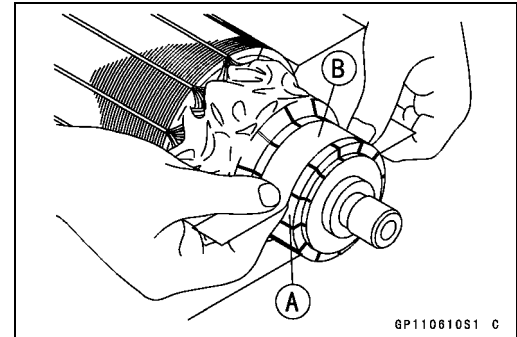

- Measure the diameter [A] of the commutator [B].
- ★ If the commutator diameter is less than the service limit, replace the starter motor with a new one .

Commutator Diameter

Standard: 28 mm (1.10 in.)

Service Limit: 27 mm (1.06 in.)

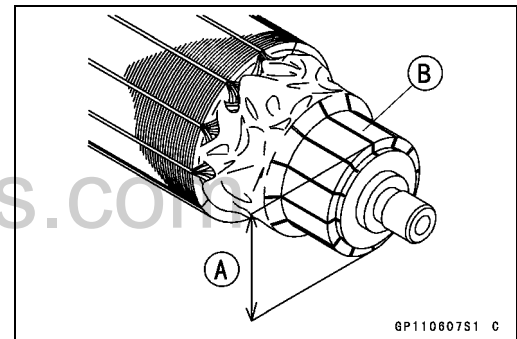

Armature Inspection

- Using the $\times 1 \Omega$ hand tester range, measure the resistance between any two commutator segments [A].

Special Tool - Hand Tester: 57001-1394

- ★ If there is a high resistance or no reading (∞) between any two segments, a winding is open and the starter motor must be replaced.
- Using the highest hand tester range, measure the resistance between the segments and the shaft [B].
- ★ If there is any reading at all, the armature has a short and the starter motor must be replaced.

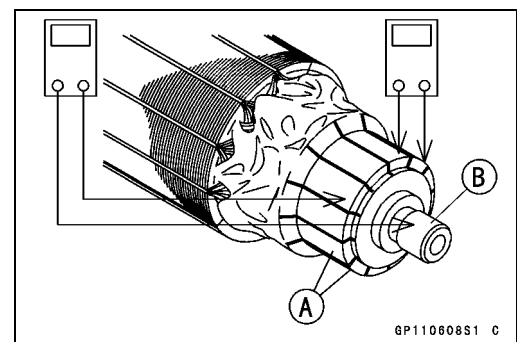

NOTE

- Even if the foregoing checks show the armature to be good, it may be defective in some manner not readily detectable with the hand tester. If all other starter motor and starter motor circuit components check good, but the starter motor still does not turn over or only turns over weakly, replace the starter motor with a new one.

Electric Starter System

Brush Lead Inspection

- Using the $\times 1 \Omega$ hand tester range, measure the resistance as shown.

Terminal Bolt and Positive Brush [A]
 Right-hand End Cover and Negative Brush [B]

Special Tool - Hand Tester: 57001-1394

- ★ If there is not close to zero ohms, the brush lead has an open. Replace the brush holder assembly.

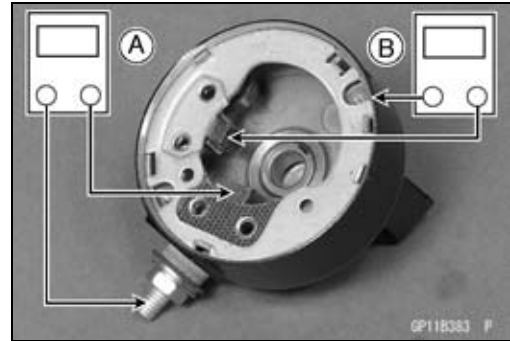

Right-hand End Cover Assembly Inspection

- Using the highest hand tester range, measure the resistance as shown.

Terminal and Right-hand End Cover [A]

Special Tool - Hand Tester: 57001-1394

- ★ If there is any reading, the right-hand end cover assembly have a short. Replace the right-hand end cover assembly.

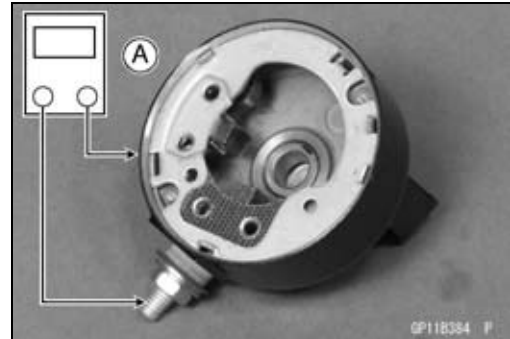

Starter Relay Inspection

- Remove the battery negative (-) cable from the battery negative (-) terminal (see Battery Removal).
- Remove the Fuel Tank (see Fuel Tank Removal in the Fuel System (DFI) chapter).
- Disconnect the connector [A].
- Disconnect the starter motor cable [B] and battery positive (+) cable [C] from the starter relay [D].

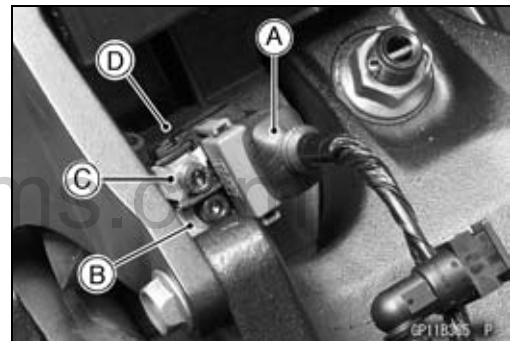

CAUTION

The battery positive (+) cable with the rubber cap is connected directly to the battery positive (+) terminal even when the ignition switch off, so take care not to short the removed cable to chassis ground.

- Pull out the starter relay from the damper.
- Connect the hand tester [A] and 12 V battery [B] to the starter relay [C] as shown.

Special Tool - Hand Tester: 57001-1394

- ★ If the relay does not work as specified, the relay is defective. Replace the relay.

Testing Relay

Tester Range: $\times 1 \Omega$ range

Criteria: When battery is connected $\rightarrow 0 \Omega$

When battery is disconnected $\rightarrow \infty \Omega$

- Tighten:

Torque - Starter Motor Cable Mounting Bolt: 4.0 N·m (0.41 kgf·m, 35 in·lb)

Battery Cable Mounting Bolt: 4.0 N·m (0.41kgf·m, 35 in·lb)

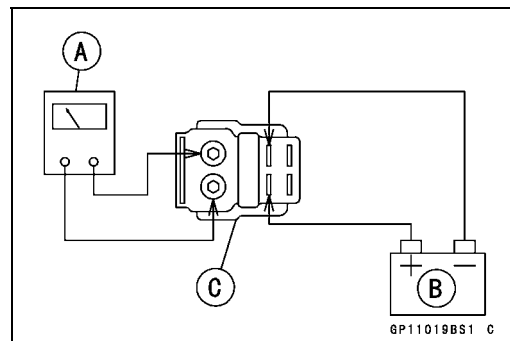

Electric Starter System

Electric Starter Circuit

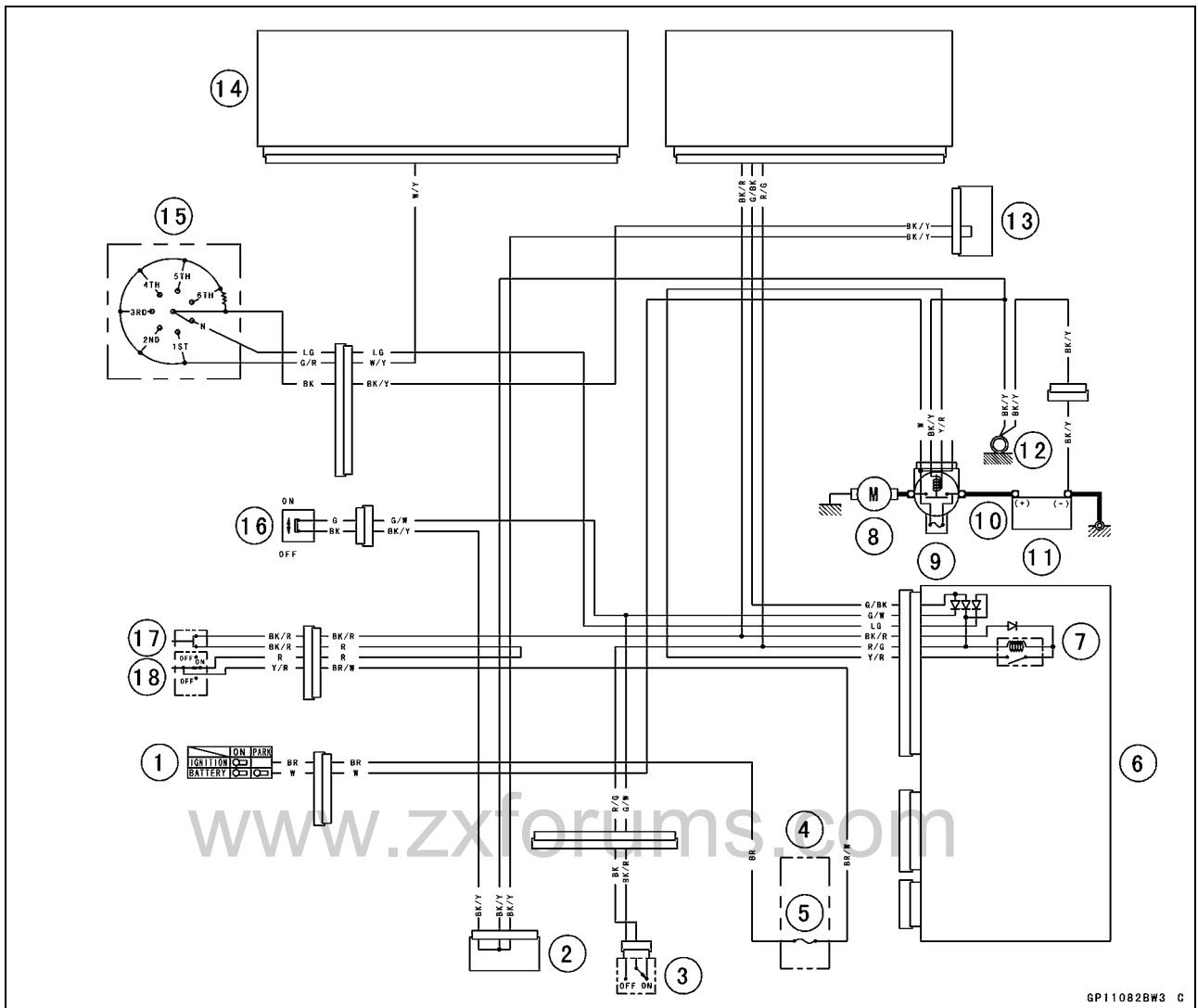

GP11082BW3 C

1. Ignition Switch
2. Joint Connector 1
3. Starter Lockout Switch
4. Fuse Box
5. Ignition Fuse 15 A
6. Relay Box
7. Starter Circuit Relay
8. Starter Motor
9. Main Fuse 30 A
10. Starter Relay
11. Battery 12 V 10 Ah
12. Frame Ground
13. Joint Connector 2
14. ECU
15. Gear Position Switch
16. Sidestand Switch
17. Starter Button
18. Engine Stop Switch

Lighting System

This motorcycle adopt the daylight system and have a headlight relay in the relay box. The headlight does not go on when the ignition switch and the engine stop switch are first turned on. The headlight comes on after the starter button is released and stays on until the ignition switch is turned off. The headlight will go out momentarily whenever the starter button is pressed and come back on when the button is released.

Headlight Beam Horizontal Vertical Adjustment

- Refer to the Headlight Aiming Inspection in the Periodic Maintenance chapter (see Headlight Aiming Inspection in the Periodic Maintenance chapter).

Headlight Beam Vertical Adjustment

- Refer to the Headlight Aiming Inspection in the Periodic Maintenance chapter (see Headlight Aiming Inspection in the Periodic Maintenance chapter).

Headlight Bulb Replacement

- Remove the upper inner fairing (see Upper Inner Fairing Removal in the Frame chapter).
- Disconnect the headlight connector [A].

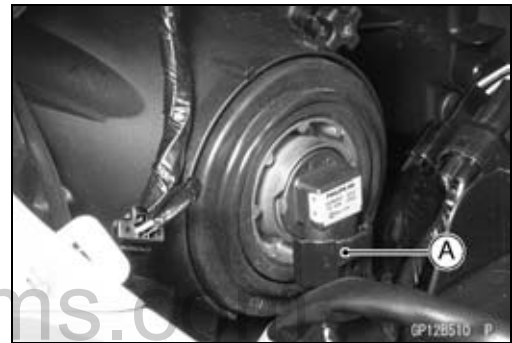

- Turn the headlight bulb [A] counterclockwise and pull out the bulb from the headlight.

www.zxforums.com

CAUTION

When handling the quartz-halogen bulb, never touch the glass portion with bare hands. Always use a clean cloth. Oil contamination from hands or dirty rags can reduce bulb life or cause the bulb to explode.

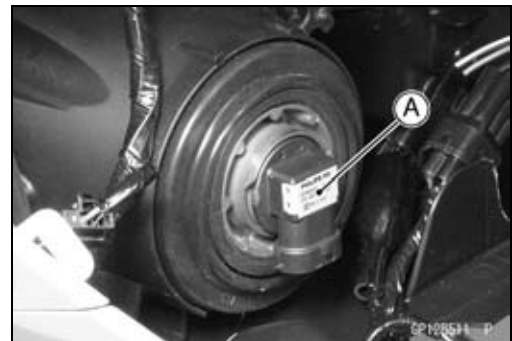

NOTE

○Clean off any contamination that inadvertently gets on the bulb with alcohol or soap and water solution.

- Replace the headlight bulb.
- Fit the projection [A] of the bulb in the hollow [B] of the headlight.

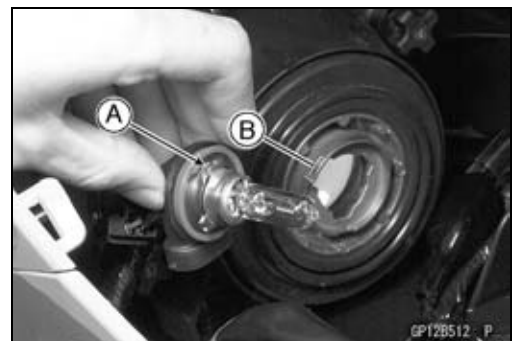

Lighting System

- Turn the headlight bulb [A] clockwise.
- Connect the headlight connector.
- After installation, adjust the headlight aim (see Headlight Aiming Inspection in the Periodic Maintenance chapter).

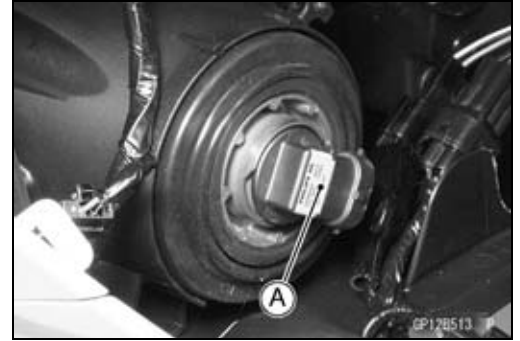

City Light Bulb Replacement

- Remove the upper inner fairing (see Upper Inner Fairing Removal in the Frame chapter).
- Pull out the socket [A] together with the bulb.

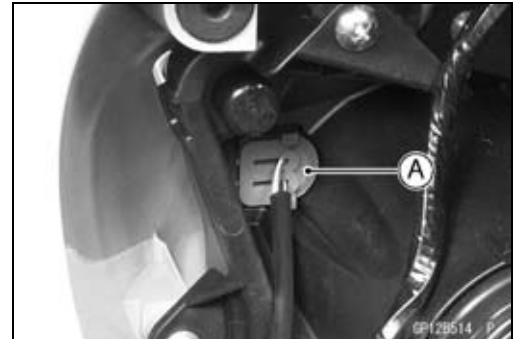

- Pull the bulb [A] out of the socket [B].

CAUTION

Do not turn the bulb. Pull the bulb out to prevent damage to the bulb. Do not use bulb rated for greater wattage than the specified value.

- Replace the bulb with a new one.

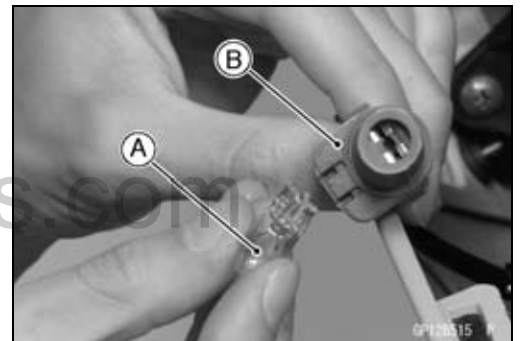

- Insert the socket and to the headlight.
- Align the projections [A] of the socket and the grooves [B] of the headlight.

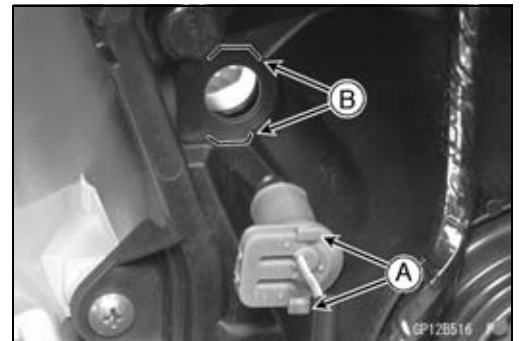

Headlight Removal/Installation

- Remove:
 - Upper Fairing (see Upper Fairing Removal in the Frame chapter)
 - Center Inner Fairing (see Center Inner Fairing Removal in the Frame chapter)
 - Meter Bracket Screws [A] and Clamp
 - Headlight Mounting Screws [B]
 - Headlight [C]
- Tighten:

Torque - Headlight Mounting Screws: 1.2 N·m (0.12 kgf·m, 11 in·lb)

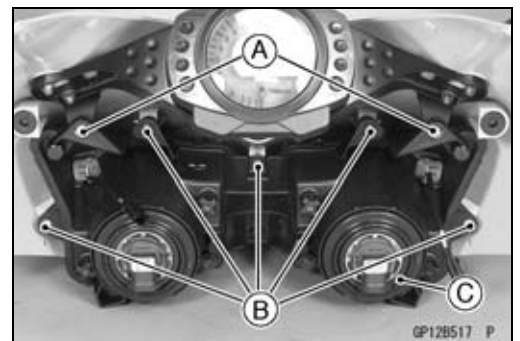

Lighting System

Tail/Brake Light (LED) Removal

- Refer to the Seat Cover Removal in the Frame chapter (see Seat Cover Removal in the Frame chapter).

Tail/Brake Light (LED) Installation

- Refer to the Seat Cover Installation in the Frame chapter (see Seat Cover Installation in the Frame chapter).

License Plate Light Bulb Replacement

- Remove:
 - Screws [A]
 - License Plate Light Cover [B]

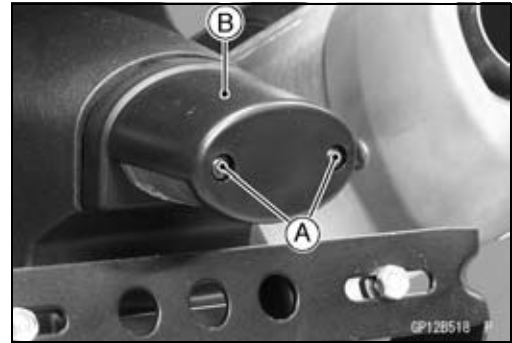

- Push and turn the bulb [A] counterclockwise and remove it.
- Replace the bulb with a new one.

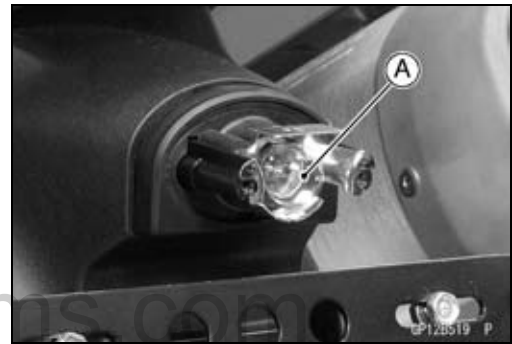

- Insert the new bulb [A] by aligning its upper and lower pins [B] with the upper and lower grooves [C] in the socket, and turn the bulb clockwise.

○ Turn the bulb about 15° degrees.

- Tighten:

Torque - Licence Plate Light Cover Screws: 1.2 N·m (0.12 kgf·m, 11 in·lb)

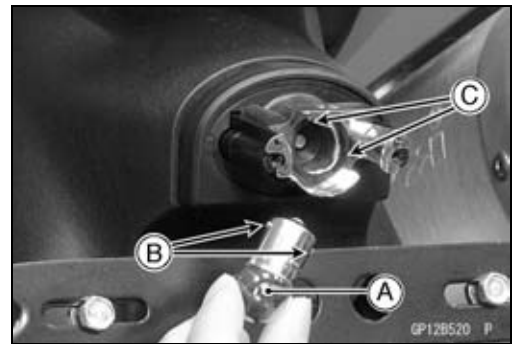

Lighting System

Headlight/Tail Light Circuit

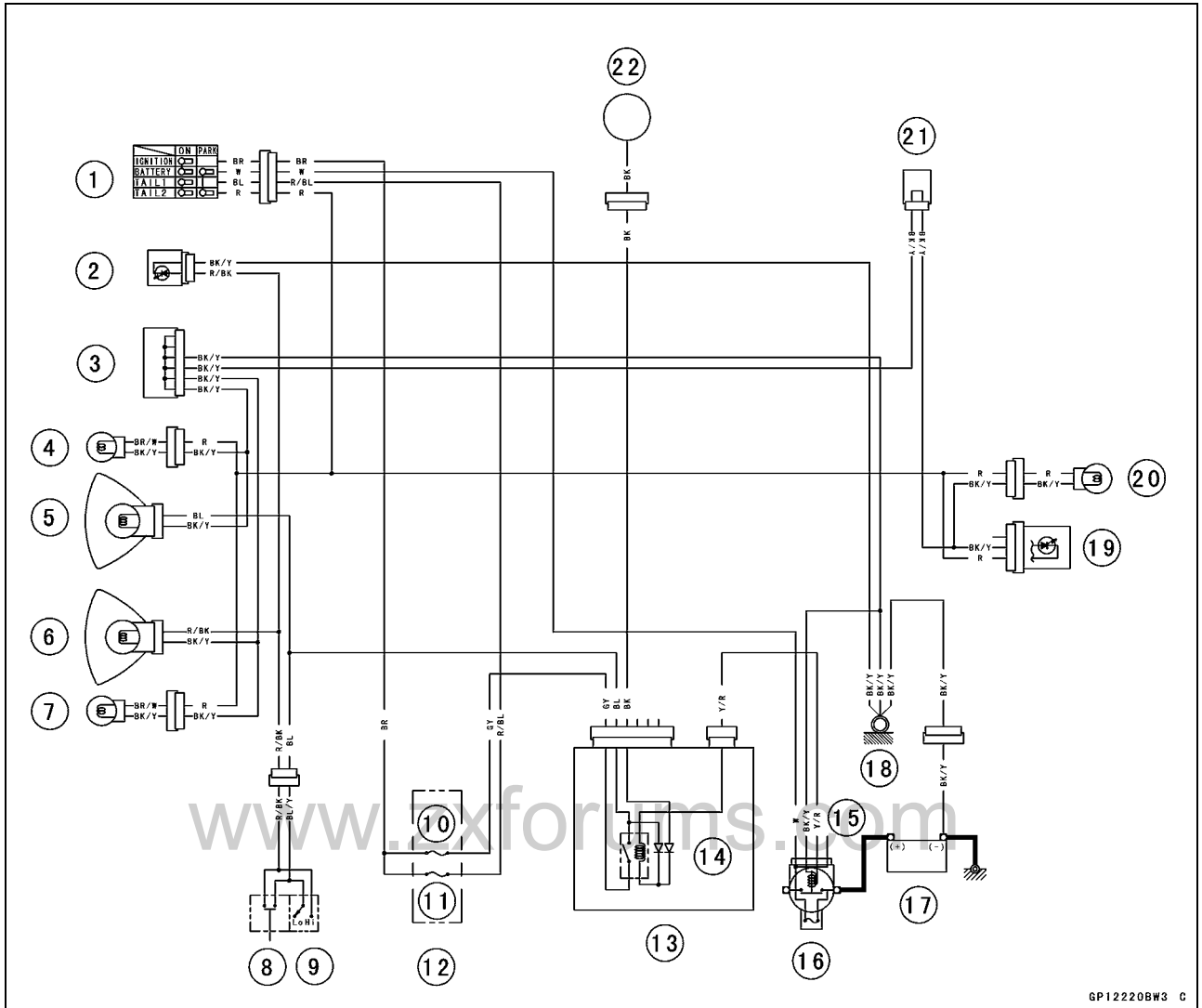

GP12220BW3 C

- | | |
|------------------------------------|----------------------------|
| 1. Ignition Switch | 12. Fuse Box |
| 2. High Beam Indicator Light (LED) | 13. Relay Box |
| 3. Joint Connector 1 | 14. Headlight Relay |
| 4. Right City Light | 15. Starter Relay |
| 6. Headlight (High Beam) | 16. Main Fuse 30 A |
| 5. Headlight (Low Beam) | 17. Battery 12 V 10 Ah |
| 7. Left City Light | 18. Frame Ground |
| 8. Passing Button | 19. Tail/Brake Light (LED) |
| 9. Dimmer Switch | 21. Joint Connector 2 |
| 10. Headlight Fuse 10 A | 22. Alternator |
| 11. Tail Light Fuse 10 A | |

Turn Signal Light Bulb Replacement

Front Turn Signal Light

- Remove the middle fairing (see Middle Fairing Removal in the Frame chapter).
- Turn the socket [A] counterclockwise and pull out the socket together with the bulb.

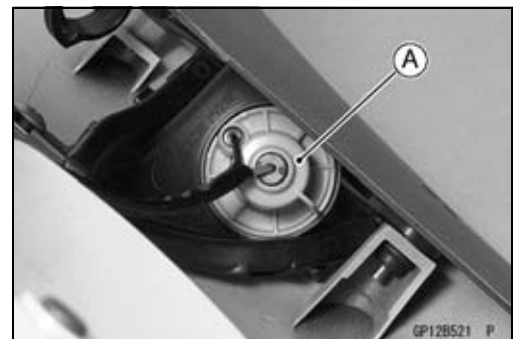

Lighting System

- Push and turn the front turn signal light bulb [A] counter-clockwise and remove it.
- Replace the bulb with new ones.

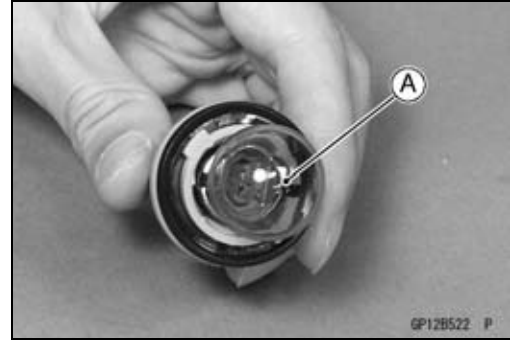

- Insert the new bulb [A] by aligning its upper and lower pins [B] with the upper and lower grooves [C] in the socket, and turn the bulb clockwise.
- Turn the bulb about 15° degrees.

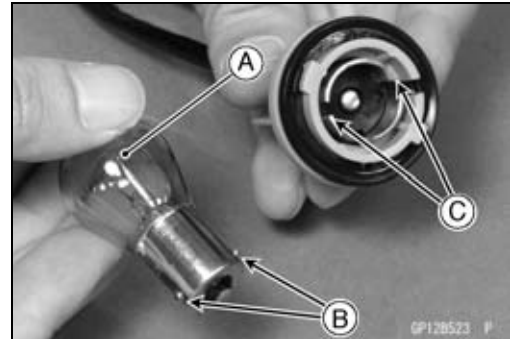

- Pushing the socket and turn it clockwise.
- Fit the projections [A] of the socket into the grooves [B] of the turn signal light.
- Install the middle fairing (see Middle Fairing Installation in the Frame chapter).

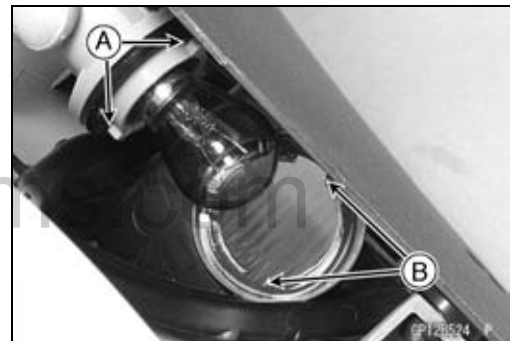

Rear Turn Signal Light

- Remove:
 - Screws [A]
 - Rear Turn Signal Light Lens [B]

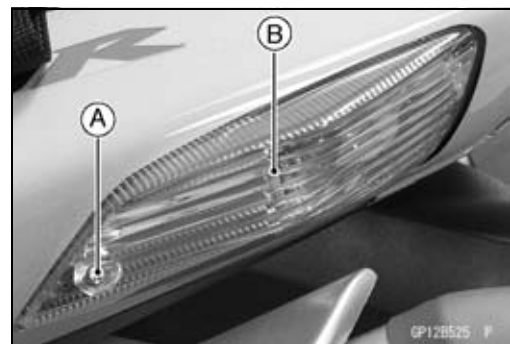

- Push and turn the rear turn signal light bulb [A] counter-clockwise and remove it.



Lighting System

- Insert the new bulb [A] by aligning its upper and lower pins [B] with the upper and lower grooves [C] in the socket, and turn the bulb clockwise.
- Turn the bulb about 15° degrees.

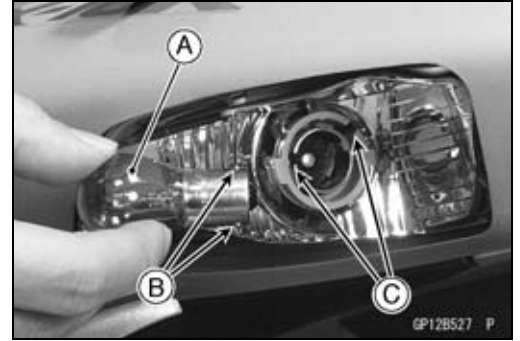

- Fit the projections [A] of the lens into the grooves [B] of the turn signal light.
- Tighten:
 - Torque - Rear Turn Signal Light Lens Screws: 1.2 N·m (0.12 kgf·m, 11 in·lb)

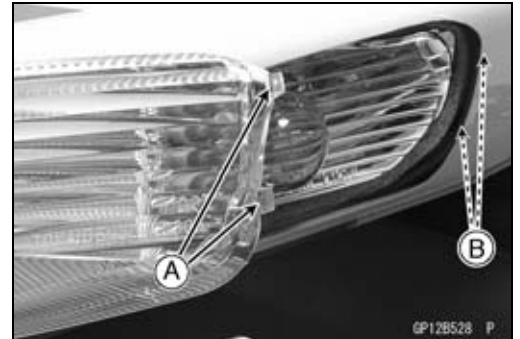

Turn Signal Relay Inspection

- Remove:
 - Seat Cover (see Seat Cover Removal in the Frame chapter)
 - Turn Signal Relay [A]
- Disconnect the connector [B].

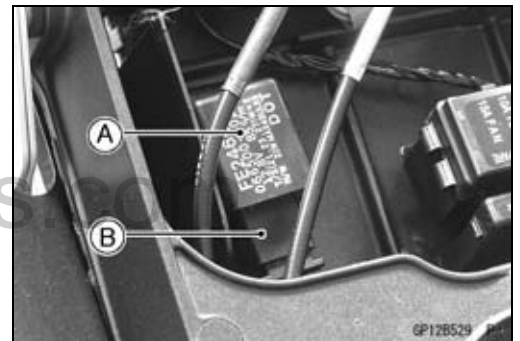

- Connect one 12 V battery and turn signal lights as indicated in the figure, and count how many times the lights flash for one minute.
 - Turn Signal Relay [A]
 - Turn Signal Lights [B]
 - 12 V Battery [C]
- ★ If the lights do not flash as specified, replace the turn signal relay.

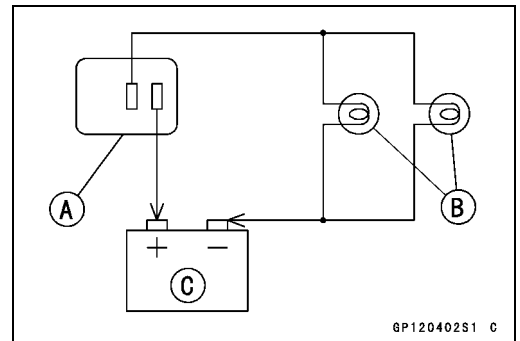

Testing Turn Signal Relay

The Number of Turn Signal Lights	Load	
	Wattage (W)	Flashing Times (c/m*)
1**	21 or 23	140-250
2	42 or 46	75-95

*: Cycle(s) per minute

** : Correspond to "one light burned out"

Lighting System

Turn Signal Light Circuit

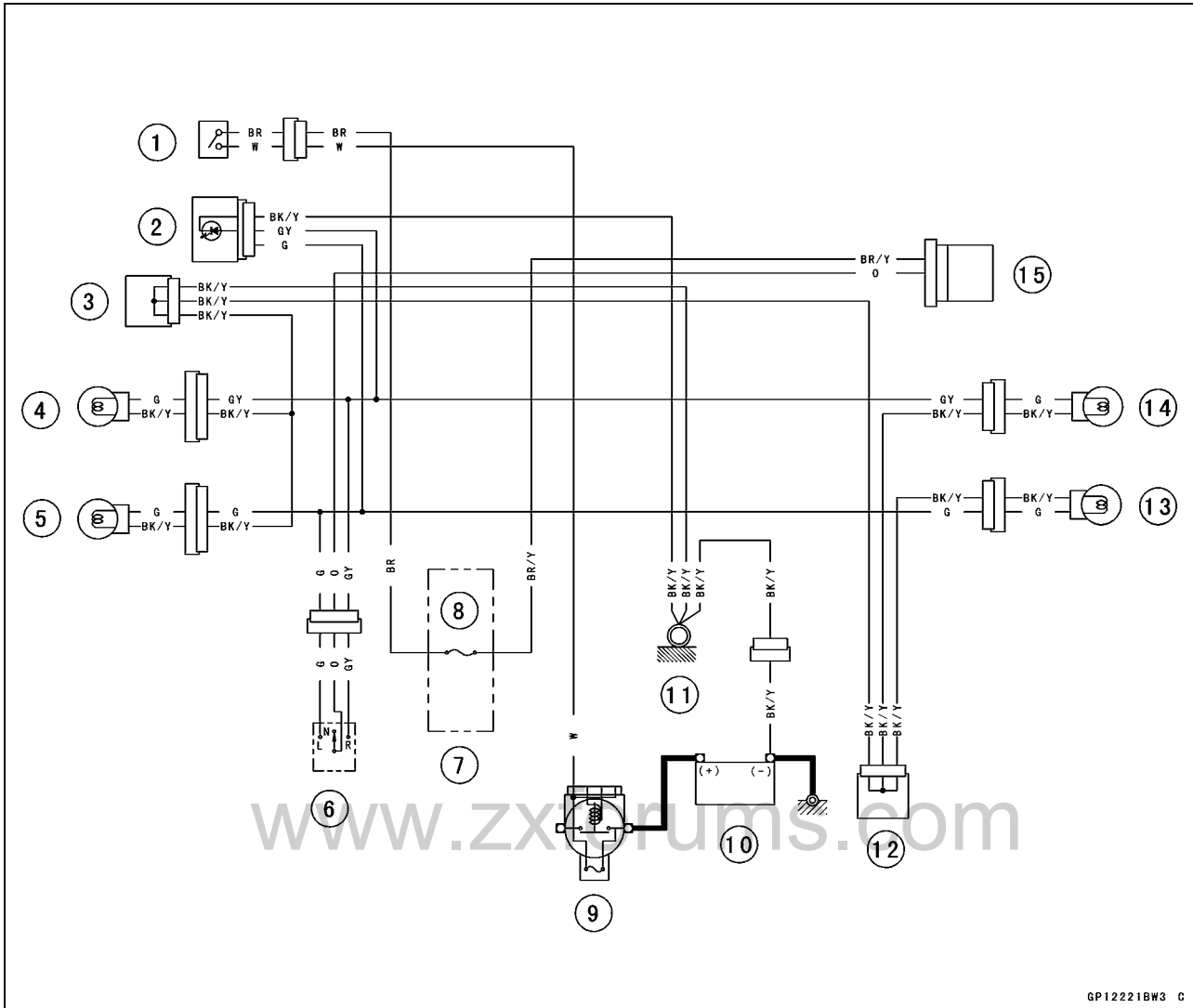

GP12221BW3 C

1. Ignition Switch
2. Turn Signal Indicator Lights (Right and Left)
3. Joint Connector 1
4. Front Right Turn Signal Light
5. Front Left Turn Signal Light
6. Turn Signal Switch
7. Fuse Box
8. Turn Signal Relay Fuse 10 A
9. Main Fuse 30 A
10. Battery 12 V 10 Ah
11. Frame Ground
12. Joint Connector 2
13. Rear Left Turn Signal Light
14. Rear Right Turn Signal Light
15. Turn Signal Relay

Air Switching Valve

Air Switching Valve Operation Test

- Refer to the Air Suction System Damage Inspection in the Periodic Maintenance chapter (see Air Suction System Damage Inspection in the Periodic Maintenance chapter).

Air Switching Valve Unit Test

- Remove the air switching valve (see Air Switching Valve Removal in the Engine Top End chapter).
- Set the hand tester [A] to the $\times \Omega$ range and connect it to the air switching valve terminals as shown.

Special Tool - Hand Tester: 57001-1394

Air Switching Valve Resistance

Standard: 18 ~ 22 Ω at 20°C (68°F)

- ★ If the resistance reading is except the specified value, replace it with a new one.
- Connect the 12 V battery [A] to the air switching valve terminals as shown.

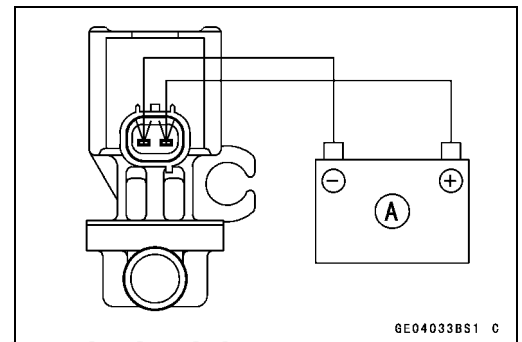
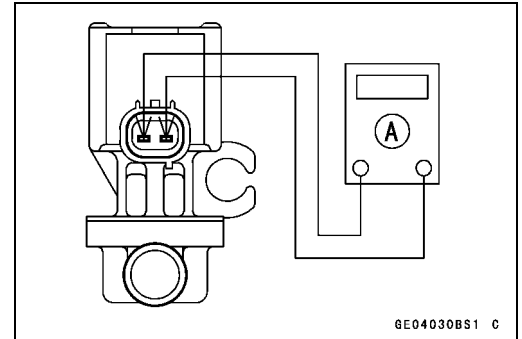

- Blow the air to the inlet air duct [A], and make sure does not flow the blown air from the outlet air ducts [B].

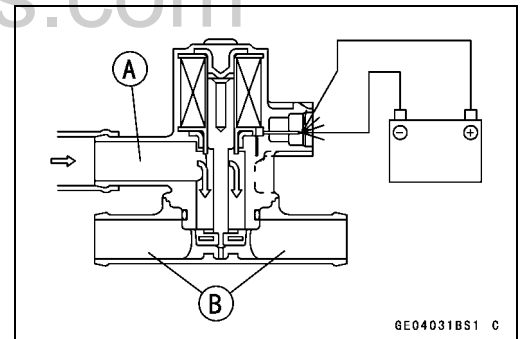

- Disconnect the 12 V battery.
- Blow the air to the inlet air duct [A] again, and make sure flow the blown air from the outlet air ducts [B].
- ★ If the air switching valve does not operate as described, replace it with a new one.

NOTE

- To check air flow through the air switching valve, just blow through the air switching valve hose (inlet side) [C].

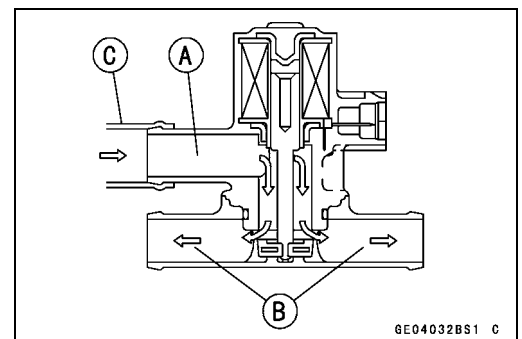

Radiator Fan System

Fan Motor Inspection

- Remove the left upper inner fairing (see Upper Inner Fairing Removal in the Frame chapter).
- Disconnect the connector [A].
- Using an auxiliary leads, supply battery power to the fan motor.
- ★ If the fan does not rotate, the fan motor is defective and must be replaced.

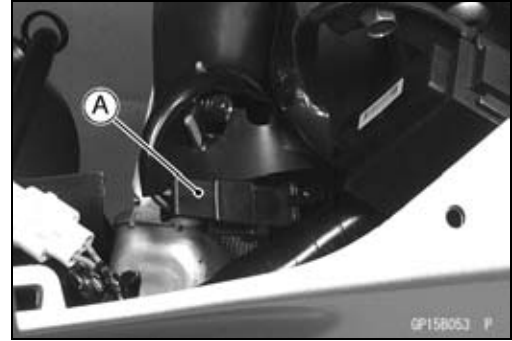

Radiator Fan Circuit

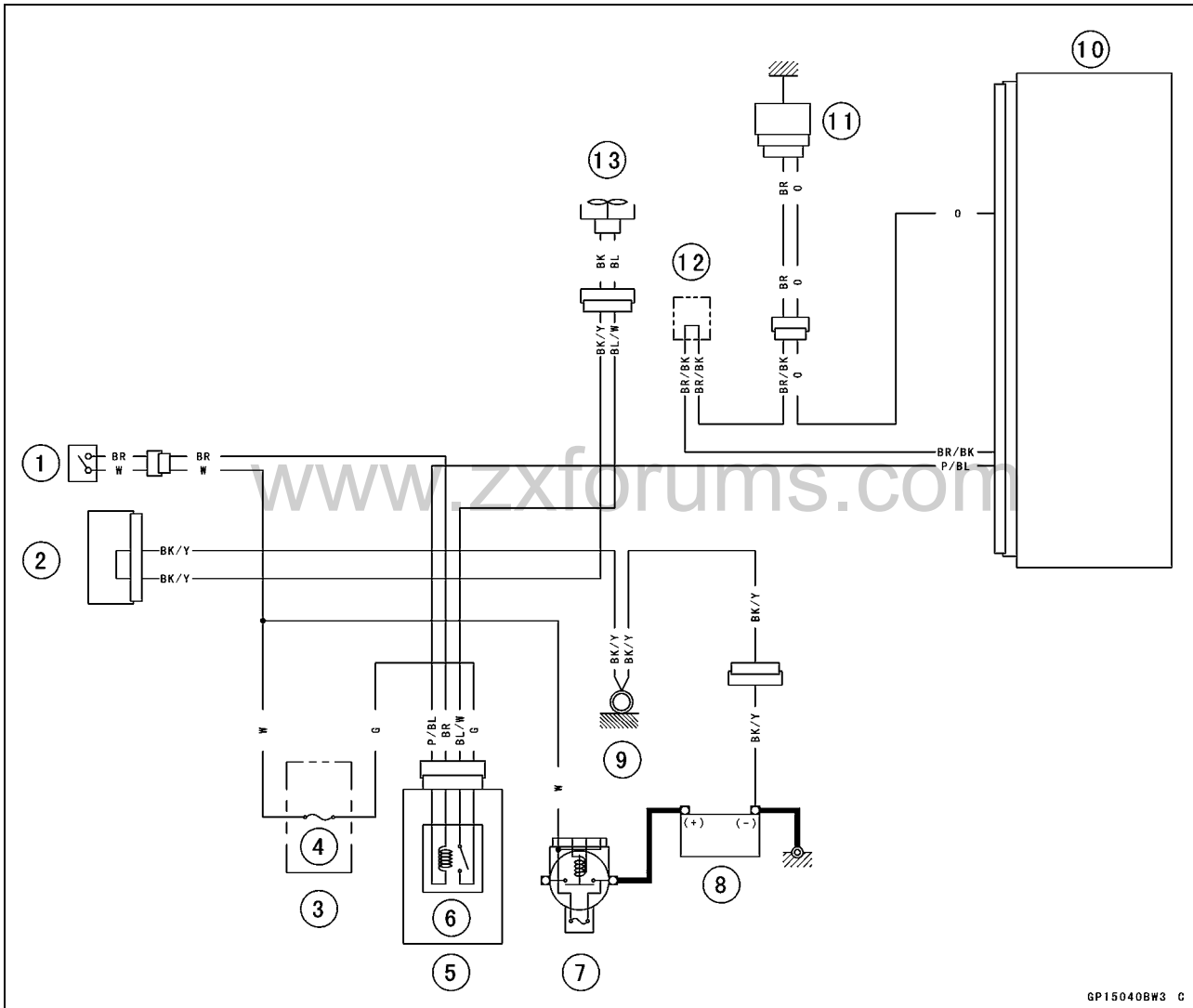

GP15040BW3 C

1. Ignition Switch
2. Joint Connector 1
3. Fuse Box
4. Fan Fuse 10 A
5. Relay Box
6. Radiator Fan Relay
7. Main Fuse 30 A
8. Battery 12 V 10 Ah
9. Frame Ground
10. ECU
11. Water Temperature Sensor
12. Water-proof Joint 2
13. Radiator Fan

Meter, Gauge, Indicator Unit

Meter Unit Removal/Installation

- Remove:
 - Upper Fairing (see Upper Fairing Removal in the Frame chapter)
 - Screws [A] with Washers

CAUTION

Place the meter unit so that the face is up. If a meter unit is left upside down or sideways for any length of time, it will malfunction.

- Tighten:
 - Torque - Meter Unit Mounting Screws: 1.2 N·m (0.12 kgf·m, 11 in·lb)

Meter Unit Disassembly

- Remove:
 - Meter Unit (see Meter Unit Removal/Installation)
 - Screws [A]
 - Lower Meter Cover [B]

- Separate the meter assembly [A] and upper meter cover [B].

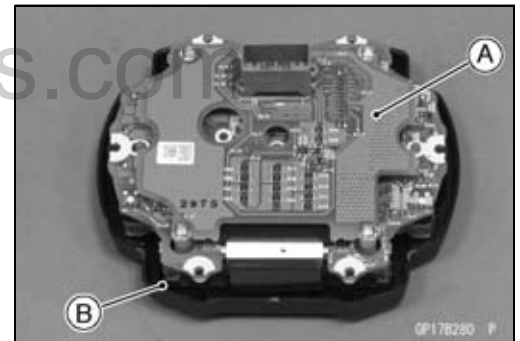
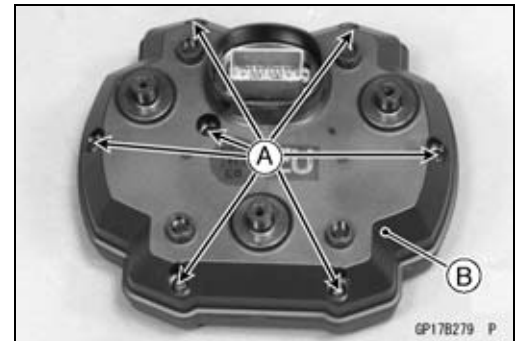
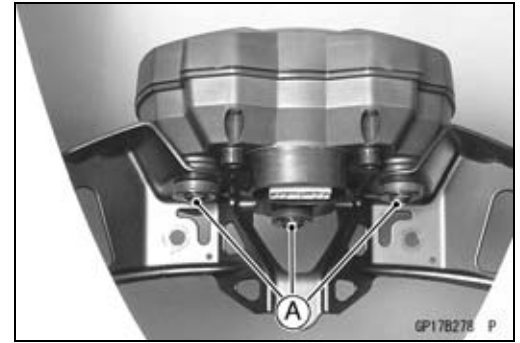

Meter, Gauge, Indicator Unit

Electronic Combination Meter Unit Inspection

- Remove the meter unit (see Meter Unit Removal) [A].
- [1] Ignition
- [2] Fuel Level Warning Indicator Light (LED) (-)
- [3] Stop Watch (+)
- [4] Lap Time (+)
- [5] Neutral Indicator Light (LED) (-)
- [6] ECU Communication Signal
- [7] Tachometer Signal
- [8] Water Temperature Sensor (-)
- [9] Unused
- [10] Unused
- [11] Ground (-)
- [12] Battery (+)
- [13] Warning Indicator Light (LED) (Oil Pressure Warning) (-)
- [14] Unused
- [15] Right Turn Signal indicator Light (LED) (+)
- [16] Left Turn Signal indicator Light (LED) (+)
- [17] High Beam Indicator Light (LED) (+)
- [18] Speed Sensor Signal
- [19] Unused
- [20] Unused

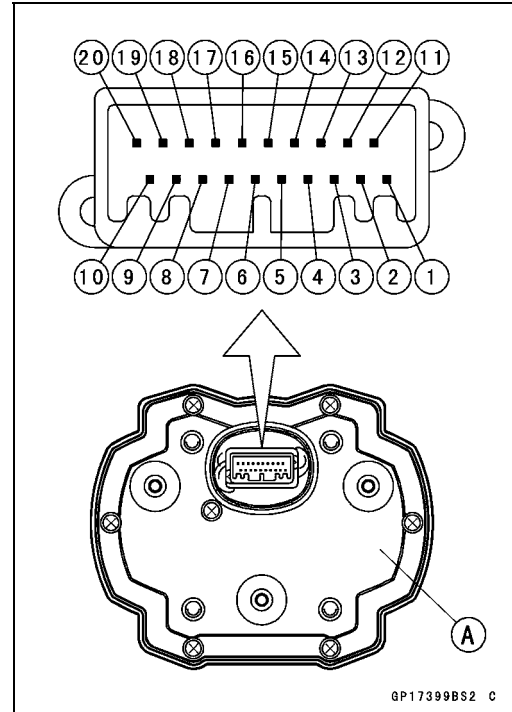

CAUTION

Do not drop the meter unit. Place the meter unit so that it faces upward. If the meter assembly is left upside down or sideways for a long time or dropped, it will malfunction. Do not short each terminals.

Liquid Crystal Display (LCD) Segments Check

- Using the insulated auxiliary leads, connect the 12 V battery to the meter unit connector as follows.
- Connect the battery positive terminal to the terminal [12].
- Connect the battery negative terminal to the terminal [11].

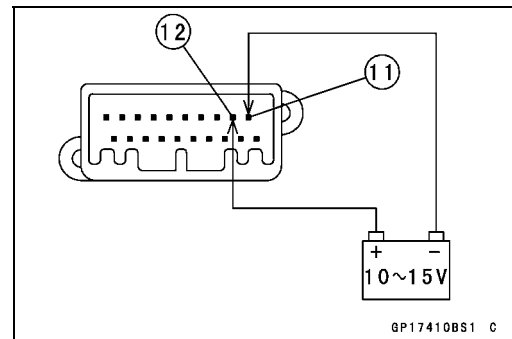

- Connect the terminal [1] to the terminal [12].

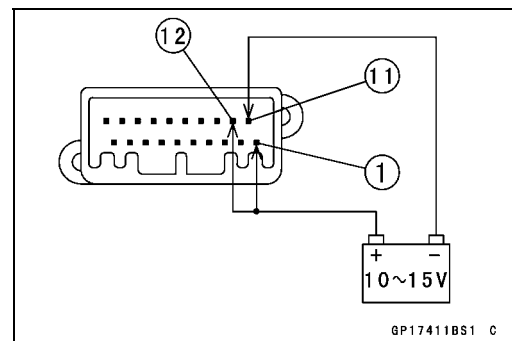

Meter, Gauge, Indicator Unit

- When the terminals are connected, all the LCD segments [A] appear for three seconds.
- ★If the LCD segments will not appear, replace the meter assembly.
- Disconnect the terminal [1].
- All the LCD segments disappear.
- ★If the segments do not disappear, replace the meter assembly.

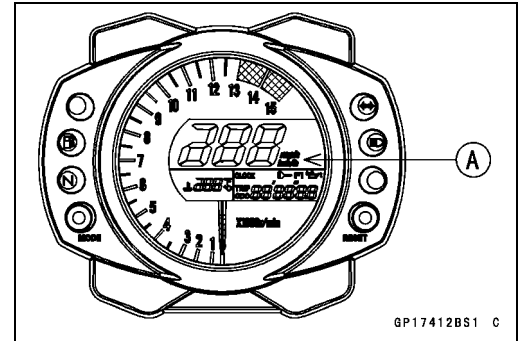

MODE AND RESET BUTTON Operation Check

- Connect the 12 V battery and terminals in the same manner as specified in the "Liquid Crystal Display (LCD) Segments Check".
- Check that the display [B] change to the ODO, TRIP, and CLOCK and STOP WATCH displays each time the MODE button [A] is pressed.
- When the fuel level warning indicator light (LED) blinked, display change to FUEL, ODO, TRIP, CLOCK and, STOP WATCH and FUEL.
- ★If the display function does not work, replace the meter assembly.

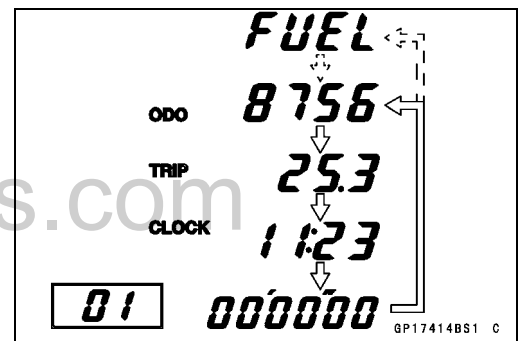
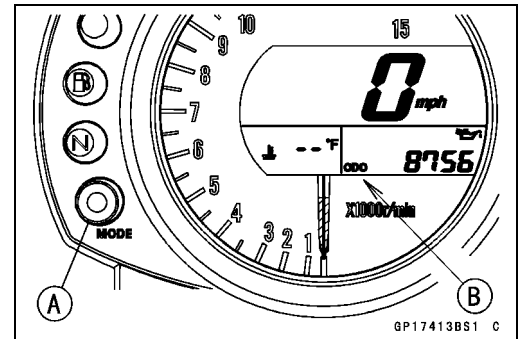

- Indicate the clock mode.
- Check that when the RESET button [A] in CLOCK mode is pushed for more than two seconds, the meter display turns to the clock set mode.
- Both the hour and minute display start flashing.

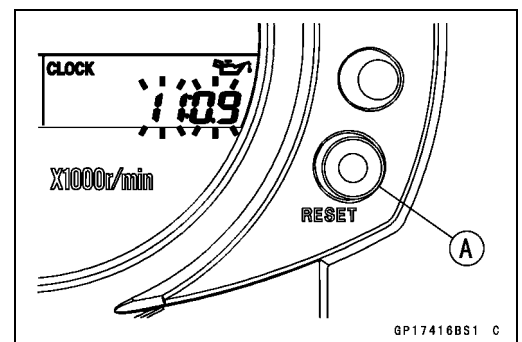

- In the HOUR/MINUTE setting mode, press the reset button [C] again to effect the HOUR setting mode.
- The hour display flashes on the display.
- Press the MODE button [A] to set the hour.

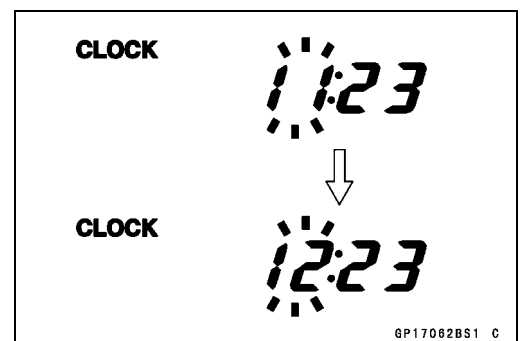

Meter, Gauge, Indicator Unit

- In the HOUR setting mode, press the REST button to effect the MINUTE setting mode.
- The minute display flashes on the display.
- Press the MODE button to set the minute.

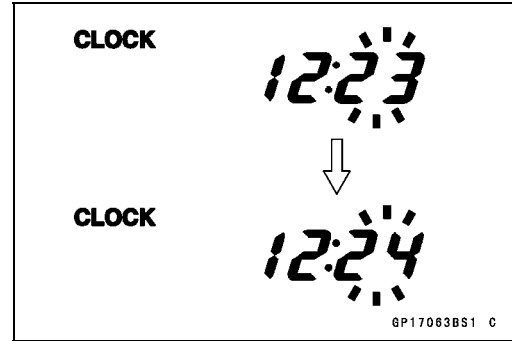

- In the MINUTE setting mode, press the REST button to return to the HOUR/MINUTE setting mode.
- Press the MODE button to complete the time setting process.
- The clock starts counting the seconds as soon as the MODE button is pressed.

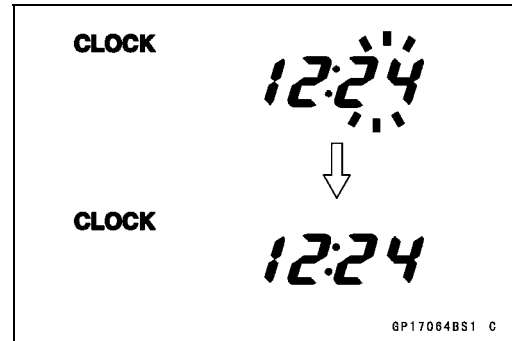

- Indicate the ODO mode.
- Check that the display [A] [B] change to the mile and °F, Mile and °C, km and °F, km and °C display each time by pushing the RESET bottom while MODE bottom pushed in.

NOTE

○ Mile/Km Display can alternate between English and metric modes (mile and km) in the digital meter. Make sure that km or mile according to local regulations is correctly displayed before riding.

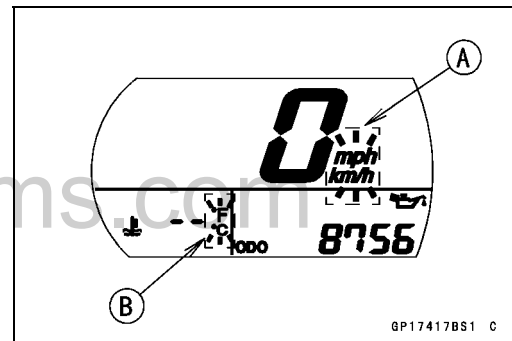

★ If the display function does not work and adjust, replace the meter assembly.

Speedometer Check

- Connect the 12 V battery and terminals in the same manner as specified in the "Liquid Crystal Display (LCD) Segments Check".
- The speed equivalent to the input frequency is indicated in the oscillator [A], if the square wave (illustrated as shown) would be input into the terminal [18].
- Indicates approximately 60 km/h in case the input frequency would be approximately 575 Hz.
- Indicates approximately 60 mph in case the input frequency would be approximately 920 Hz.

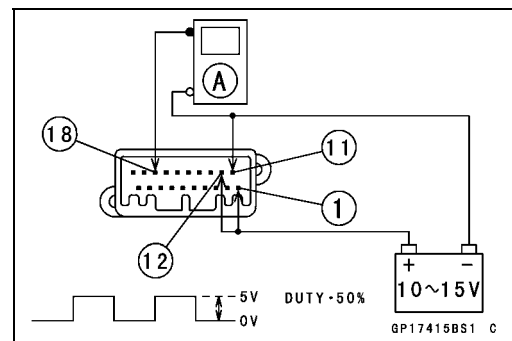

Meter, Gauge, Indicator Unit

- If the oscillator is not available, the speedometer can be checked as follows.
- Install the meter unit.
- Raise the rear wheel off the ground, using the jack.
- Turn on the ignition switch.
- Rotate the rear wheel by hand.
- Check that the speedometer shows the speed.
- ★ If the speedometer does not work, check the speed sensor and wiring (see Speed Sensor section in the Fuel System (DFI) chapter).
- ★ If the speed sensor and wiring are normal, replace the meter assembly.

Odometer Check

- Check the odometer with the speedometer check in the same way.
- ★ If value indicated in the odometer is not added, replace the meter assembly.

NOTE

- The data is maintained even if the battery is disconnected.
- When the figures come to 999999, they are stopped and locked.

Trip Meter Check

- Check the trip meter with the speedometer in the same way.
- ★ If value indicated in the trip meter is not added, replace the meter assembly.
- Check that when the RESET button is pushed for more than two seconds, the figure display turns to 0.0.
- ★ If the figure display does not indicate 0.0, replace the meter assembly.

Water Temperature Meter Check

- Connect the 12 V battery and terminals in the same manner as specified in the "Liquid Crystal Display (LCD) Segments Check".
- Connect the variable rheostat [A] to the terminal [8] as shown.
- Check that the number of segments matches the resistance value of the variable rheostat.

Resistance Value (Ω)	Temperature Meter	Warning Indicate
	--	- [A]
209.8	50°C (122°F)	- [B]
69.1	80°C (176°F)	- [B]
21.2	120°C (248°F)	Flash [C]
17	HI	Flash [D]

- If any display function does not work, replace the meter assembly.

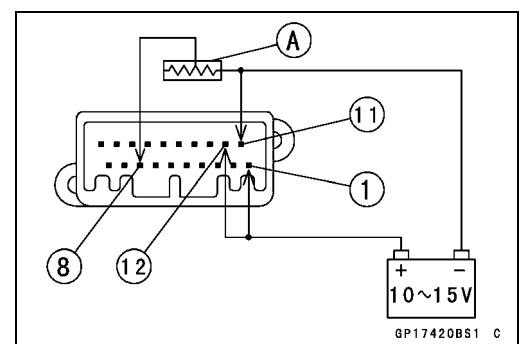
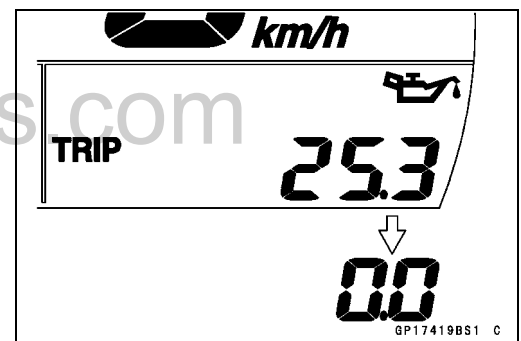
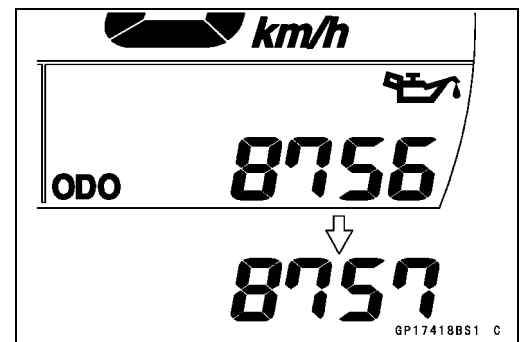

Meter, Gauge, Indicator Unit

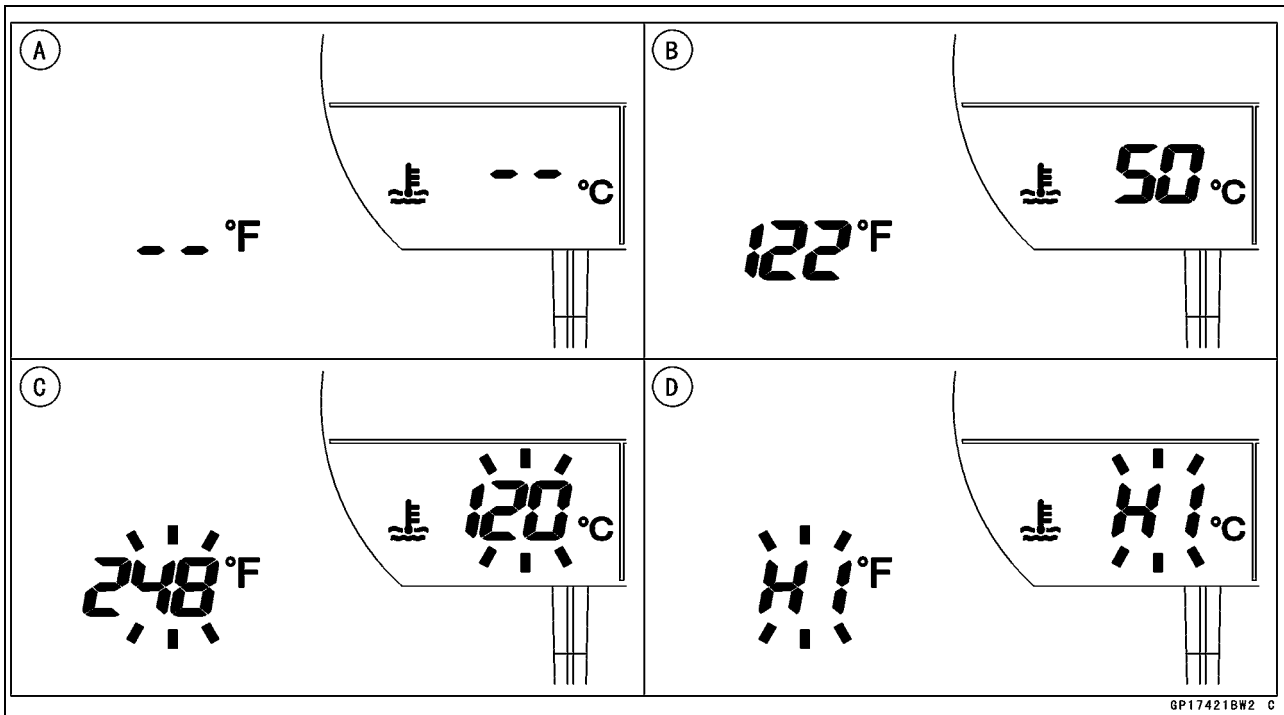

GP17421BW2 C

Tachometer Check

- Connect the 12 V battery and terminals in the same manner as specified in the "Liquid Crystal Display (LCD) Segments Check".
- When the terminals are connected, the tachometer needle momentarily points to the last reading, and then return to the 0 position.
- ★ If the needle function does not work, replace the meter assembly.
- The revolutions per minute (rpm) equivalent to the input frequency is indicated in the oscillator [A] if the square wave (illustrated as shown) would be input into the terminal [7].
- Indicates approximately 4 000 rpm in case the input frequency would be approximately 133.3 Hz.
- If the oscillator is not available, the tachometer can be checked as follows.
- Connect the 12 V battery and terminals in the same manner as specified in the "Liquid Crystal Display (LCD) Segments Check".
- When the terminals are connected, the tachometer needle momentarily points to the last reading, and then return to the 0 position.
- ★ If the needle function does not work, replace the meter assembly.
- Using the insulated auxiliary lead, quickly open and connect the terminal [1] to the terminal [7] repeatedly.
- Then the tachometer needle [A] should flick [B].
- ★ If the hand does not flick, replace the meter assembly.

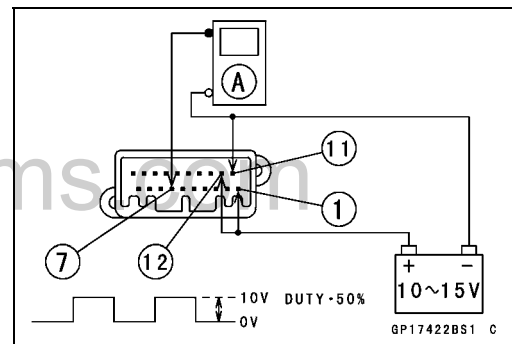

GP17422BS1 C

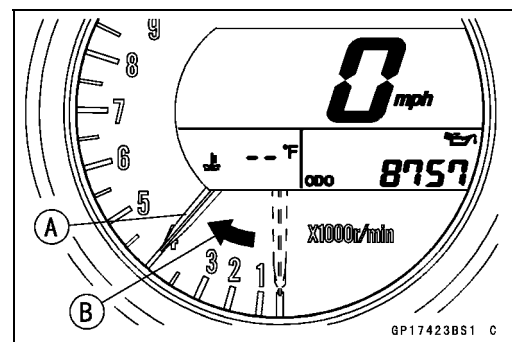

GP17423BS1 C

Meter, Gauge, Indicator Unit

Stop Watch Check

- Connect the 12 V battery and terminal in the same manner as specified in the "Liquid Crystal Display (LCD) Segments Check".
- Press the MODE button each time to set the stop watch mode.
- Connect the insulated auxiliary lead processed insulation to the terminal [3] as shown, then stop watch start to count.
- While count the stop watch, connect the auxiliary lead to the terminal [4] as shown, then indicate the counted time during ten seconds.
- Connect the variable rheostat [A] to the terminal [8] as shown.
- When Set the resistance to less than 21.1Ω , lap display segment indicate the water temperature.
- ★ If the display function does not work, replace the meter assembly.

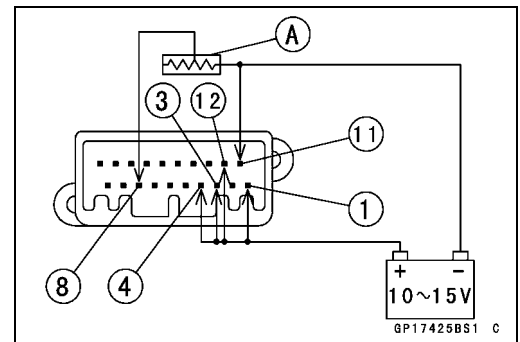
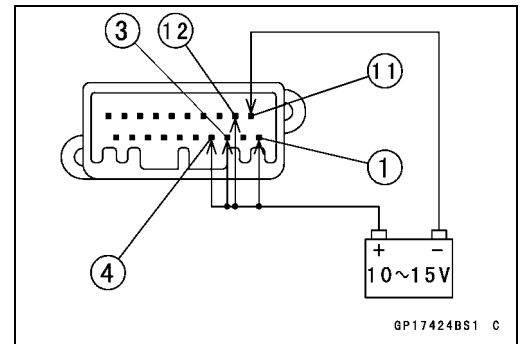

Lights (LED) Inspection

- Connect the 12 V battery and terminals in the same manner as specified in the "Liquid Crystal Display (LCD) Segments check."
Shift Up Indicator Light (LED) [A]
Fuel Level Warning Indicator Light (LED) [B]
Neutral Indicator Light (LED) [C]
Turn Signal Indicator Light [D]
High Beam Indicator Light (LED) [E]
Warning Indicator Light (LED) (FI/Immobilizer/Oil Pressure Warning) [F]
Illumination Light (LED) [G]

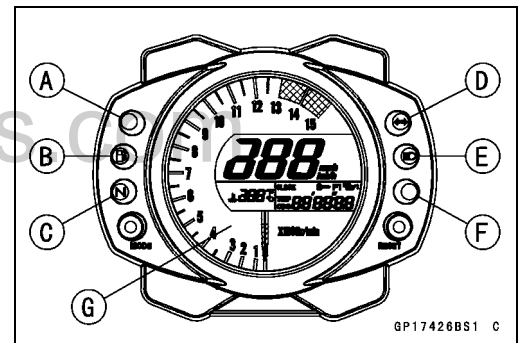

Illumination Light (LED) Inspection

- Connect the 12 V battery and terminals in the same manner as specified in the "Liquid Crystal Display (LCD) Segments check."
- When the terminals are connected, the illumination light (LED) should go on.
- ★ If the illumination light (LED) does not go on, replace the meter assembly.
- Check whether the level of the illumination light (LED) can be adjusted in four levels by pushing the RESET button each time.
- ★ If the light level does not changes, replace the meter assembly.

Meter, Gauge, Indicator Unit

Neutral Indicator Light (LED) Inspection

- Connect the 12 V battery and terminals in the same manner as specified in the “Liquid Crystal Display (LCD) Segments check.”
- Using the insulated auxiliary lead, 12 V battery to the meter unit connector as follows.
- Connect the battery negative (-) terminal to the terminal [5].
- When the terminals are connected, the neutral indicator light (LED) should go on.
- ★ If the neutral indicator light (LED) does not go on, replace the meter assembly.

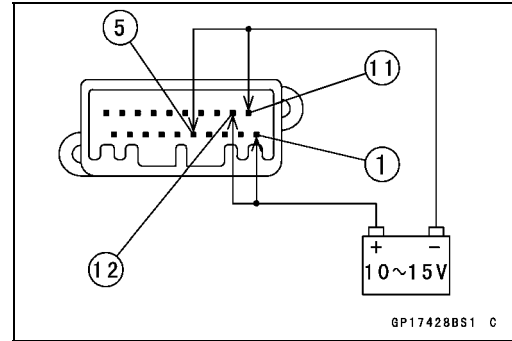

Warning Indicator Light (LED) (Oil Pressure Warning) Inspection

- Connect the 12 V battery and terminals in the same manner as specified in the “Liquid Crystal Display (LCD) Segments check.”
- Using the insulated auxiliary lead, 12 V battery to the meter unit connector as follows.
- Connect the battery negative (-) terminal to the terminal [13].

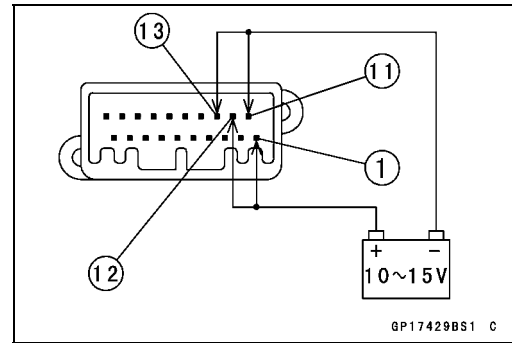

- When the terminals are connected, the warning indicator light (LED) [A] and symbol [B] blinks.
- ★ If the warning indicator light and/or symbol do not blink, replace the meter assembly.

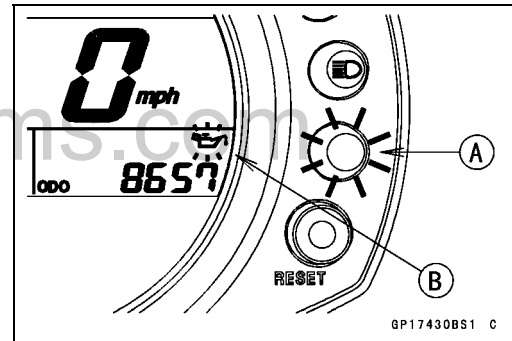

Right and Left Turn Signal Indicator Light (LED)

- Connect the 12 V battery and terminals in the same manner as specified in the “Liquid Crystal Display (LCD) Segments check.”
- Using the insulated auxiliary leads, 12 V battery to the meter unit connector as follows.
- Connect the battery positive (+) terminal to the terminal [15].
- Connect the battery negative (-) terminal to the terminal [16].

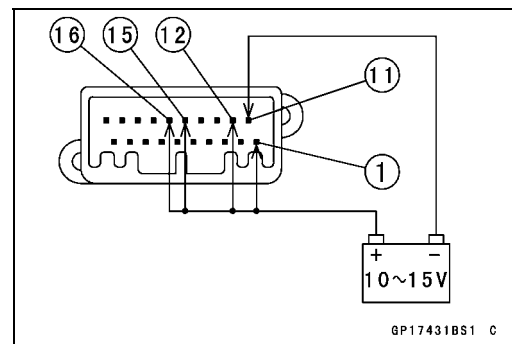

- When the terminals are connected, the turn signal indicator light (LED) should go on.
- ★ If the turn signal indicator light (LED) does not go on, replace the meter assembly.

Meter, Gauge, Indicator Unit

High Beam Indicator Light (LED)

- Connect the 12 V battery and terminals in the same manner as specified in the “Liquid Crystal Display (LCD) Segments check.”
- Using the insulated auxiliary lead, 12 V battery to the meter unit connector as follows.
- Connect the battery positive (+) terminal to the terminal [17].

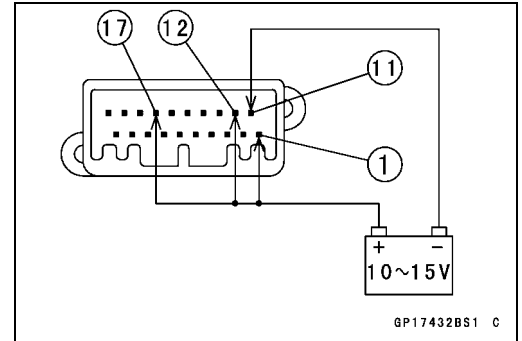

- When the terminals are connected, the high beam indicator light (LED) should go on.
- ★ If the turn signal high beam indicator light (LED) does not go on, replace the meter assembly.

Fuel Level Warning Indicator Light (LED)

- Connect the 12 V battery and terminals in the same manner as specified in the “Liquid Crystal Display (LCD) Segments check.”
- Connect the variable rheostat [A] to the terminal [2] as shown.
- Adjust the resistance value to the approximately 10 Ω.

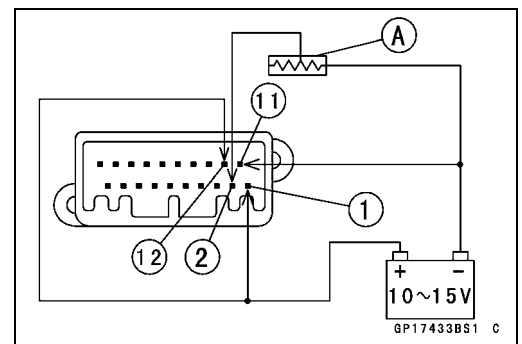

- When the terminals are connected, the fuel level warning indicator light (LED) [A] should go on and the FUEL segments [B] flashes on the display.
- ★ If the fuel level warning indicator light (LED) does not go on and/or the Fuel segments does not displayed, replace the meter assembly.

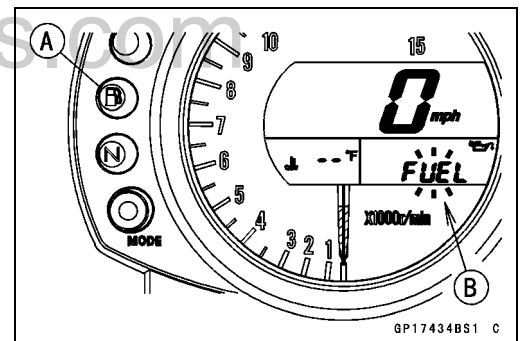

- Disconnect the terminal [2].
- When the terminal is disconnected, the fuel level warning indicator light (LED) [A] blinks and the FUEL segments [B] flashes on the display.
- ★ If the fuel level warning indicator light (LED) does not blink and/or the Fuel segments does not displayed, replace the meter assembly.

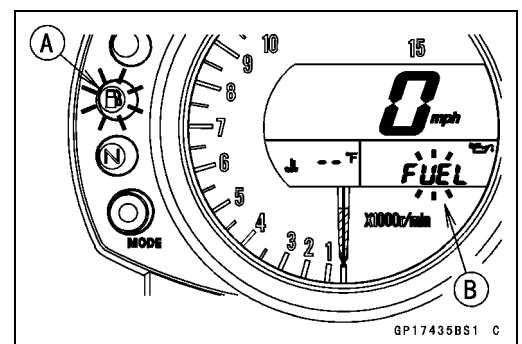

Meter, Gauge, Indicator Unit

Shift Up Indicator Light (LED)

- Connect the 12 V battery and terminal in the same manner as specified in the “Liquid Crystal Display (LCD) Segments Check”.
- The revolutions per minute (rpm) equivalent to the input frequency is indicated in the oscillator [A] if the square wave (illustrated as shown) would be input into the terminal [7].
- When set the oscillator more than 440 Hz, shift up indicator light (LED) go on.
- ★ If the Shift Up Indicator Light (LED) does not go on, replace the meter assembly.

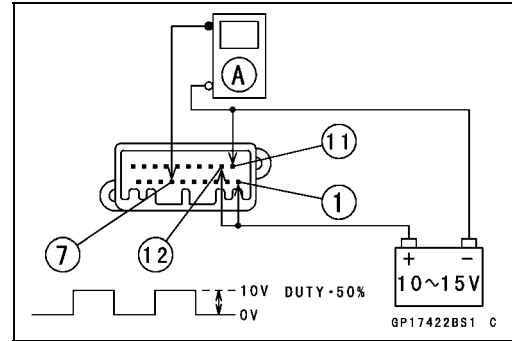

Meter, Gauge, Indicator Unit

Meter Unit Circuit

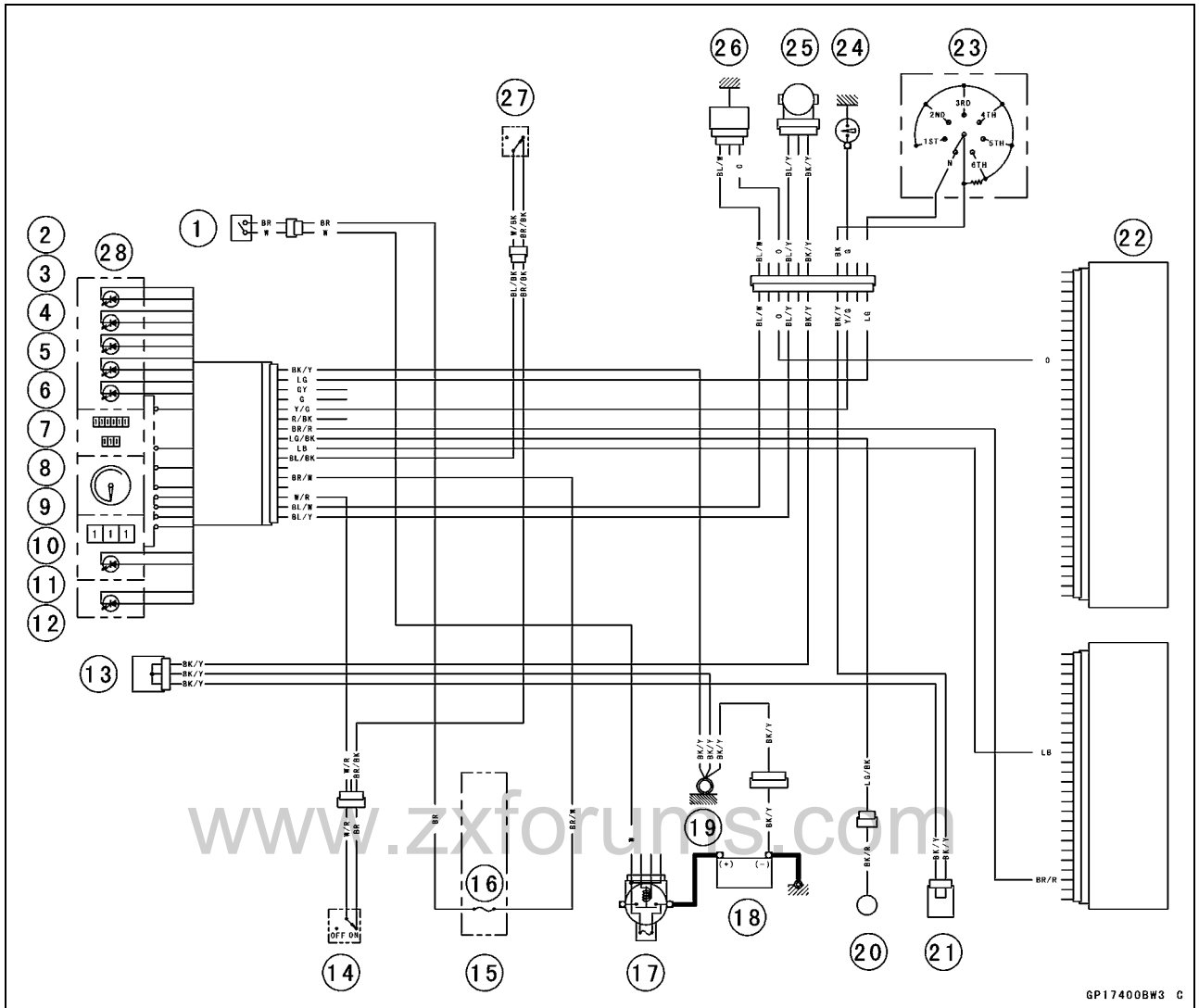

GP17400BW3 C

- | | |
|--|------------------------------|
| 1. Ignition Switch | 14. Lap Switch |
| 2. Turn Signal Indicator Light (LED) | 15. Fuse Box |
| 3. High Beam Indicator Light (LED) | 16. Ignition Fuse 15 A |
| 4. Neutral Indicator Light (LED) | 17. Main Fuse 30 A |
| 5. Fuel Level Warning Indicator Light (LED) | 18. Battery 12 V 10 Ah |
| 6. Warning Indicator Light (LED) (FI/Immobilizer/Oil Pressure Warning) | 19. Frame Ground |
| 7. Odometer/Trip Meter/Clock/Stop Watch Indicator | 20. Fuel Reserve Switch |
| 8. Water Temperature Gauge | 21. Joint Connector 2 |
| 9. Tachometer | 22. ECU |
| 10. Speedometer | 23. Gear Position Switch |
| 11. Illumination Light (LED) | 24. Oil Pressure Switch |
| 12. Shift Up Indicator Light (LED) | 25. Speed Sensor |
| 13. Joint Connector 1 | 26. Water Temperature Sensor |
| | 27. Stop Watch Switch |
| | 28. Meter Unit |

Immobilizer System (Equipped Models)

This motorcycle is equipped with an immobilizer system to protect the motorcycle from theft. This system provides a theft proof device by means of matching a code between the inbuilt key transponder and ECU (Electronic Control Unit). If the code does not match, ignition system, injectors, sub-throttle valve actuator and exhaust butterfly valve actuator will not operate and the engine will not start.

Abstract

- Do not keep more than one immobilizer key of any system on a key ring. Jamming of the key code signal may occur and the operation of the system may be affected.
- If the warning indicator light (LED) and oil pressure warning symbol flashes about 3 seconds after the ignition key is turned ON, this shows that the warning indicator light (LED) works as the oil pressure warning indicator. As long as the FI and immobilizer symbols do not flash, the DFI and immobilizer systems are operating correctly.
- If the warning indicator light (LED) and FI warning symbol flashes about 3 seconds after the ignition key is turned ON, this shows a fault in the DFI system. Refer to the service code to identify the faulty component.
- If the warning indicator light (LED) and immobilizer warning symbol flashes about 3 seconds after the ignition key is turned ON, this shows a fault in the immobilizer system. Refer to the service code to identify the faulty component.
- The warning indicator light (LED) will flash for a period of 24 hours once the ignition switch has been switched off and the key removed. This flashing can be set to on or off as desired by holding the Mode and Reset buttons down for two seconds within twenty seconds of switching the ignition off.
- If all coded keys (master key and user keys) are lost the ECU and ignition switch will have to be replaced.
- The immobilizer system can not function until the master key code is registered in the ECU.
- A total of six keys can be registered in the ECU at any one time (one master key and five user keys).
- If the master key is lost it is not possible to register new user keys.

Operational Cautions

1. Do not put two keys of any immobilizer system on the same key ring.
2. Do not submerge any key in water.
3. Do not expose any key to excessively high temperature.
4. Do not place any key close to magnet.
5. Do not place a heavy item on any key.
6. Do not grind any key or alter its shape.
7. Do not disassemble the plastic part of any key.
8. Do not drop the key and/or apply any shocks to the key.
9. When a user key is lost, the user should go to his dealer to invalidate the lost key registration in the ECU.
10. When the master key is lost, the user should go to his dealer and have a new ECU installed and register a new master key and user keys.

NOTE

○ No.9 and 10 are strongly recommended to the customer to ensure security of the motorcycle.

Key Registration

Case 1: When the user key has been lost or additional spare user key is required.

- Prepare a new spare user key.
- Cut the key in accordance with the shape of the current user key.
- Remove the front seat (see Front Seat Removal in the Frame).
- Disconnect the immobilizer/Kawasaki diagnostic system connector [A].



Immobilizer System (Equipped Models)

- Connect the key registration unit [A].
Special Tool - Key Registration Unit: 57001-1582



- Insert the master key to the ignition switch and turn it ON.
Verified

- The warning indicator light (LED) and immobilizer warning symbol [A] blinks to display the registration mode (go to the next step).

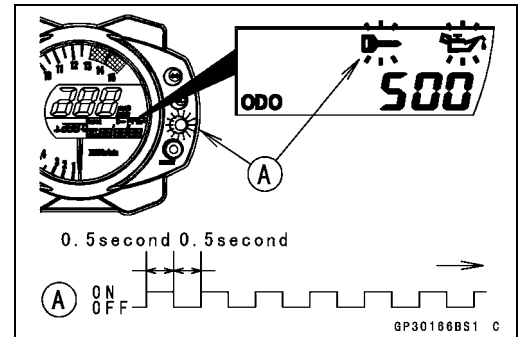

Not Verified

- The warning indicator light (LED) and immobilizer warning symbol [A] blinks to display the collation error (refer to the following failure illustrations).
Immobilizer Amplifier Failure

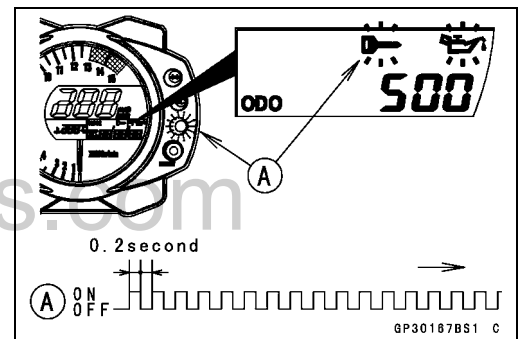

Master Key Collation Error

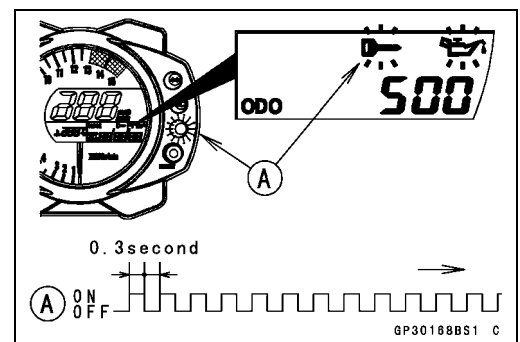

- Turn the master key OFF and remove the master key.
○The warning indicator light (LED) [A] blinks continuously to display that the ECU is in the registration mode for 15 seconds.

NOTE

- Insert next key and turn ON within 15 seconds after previous key is turned off and removed otherwise registration mode will be ended and the warning indicator light (LED) stops flashing.
- To return to the registration mode start the master key verification procedure. This applies to all user key registration.

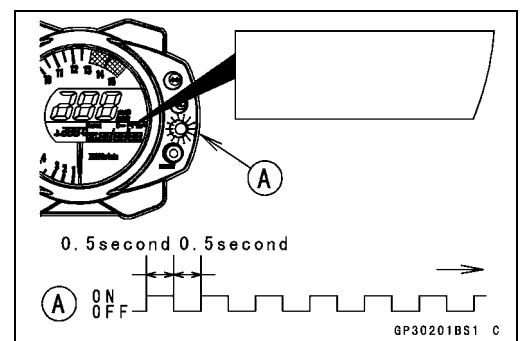

Immobilizer System (Equipped Models)

- Insert the user key 1 to the ignition switch and turn it ON.

NOTE

○Keep the other user key away from the immobilizer antenna.

- If there is any problem in the registration, the warning indicator light (LED) and immobilizer warning symbol [A] blinks to display the collation error.

Immobilizer Amplifier Failure

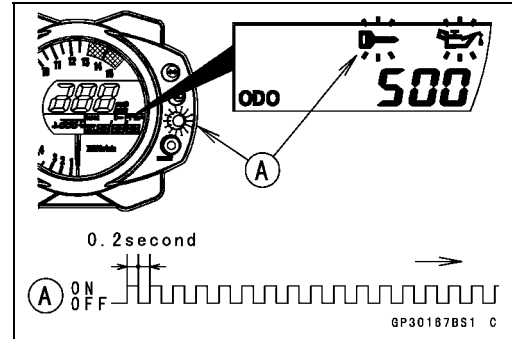

When Registered User Key is Inserted.

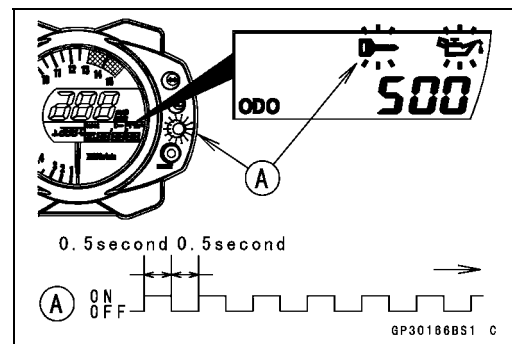

User Key Collation Error

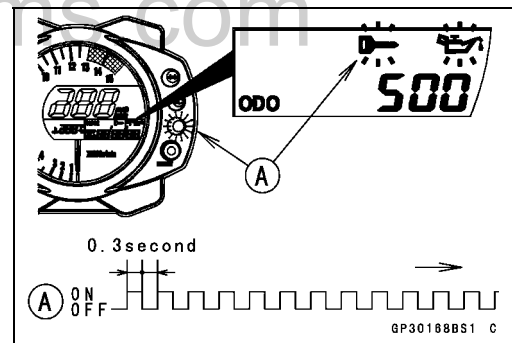

- The user key 1 is successfully registered in the ECU.
- The warning indicator light (LED) and immobilizer warning symbol [A] blinks 2 times and stops for 1 second and then repeats this cycle.

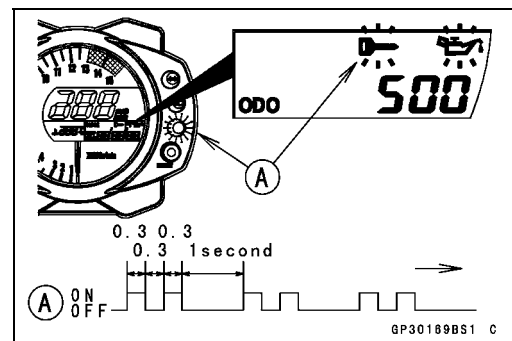

Immobilizer System (Equipped Models)

- Turn the user key 1 OFF and remove the user key 1.
- The warning indicator light (LED) [A] blinks to display the registration mode.

NOTE

- Turn off the ignition switch and wait for the period of 15 seconds or more. The registration mode automatically finishes and the warning indicator light (LED) will switch off.
- This procedure registered the master key and one user key.
- Continue with the procedure to register the second and later keys before the 15 seconds period has elapsed.
- Insert the user key 2 to the ignition switch and turn it ON.
- If there is any problem in the registration, the warning indicator light and immobilizer warning symbol [A] blinks to display the collation error.
Immobilizer Amplifier Failure

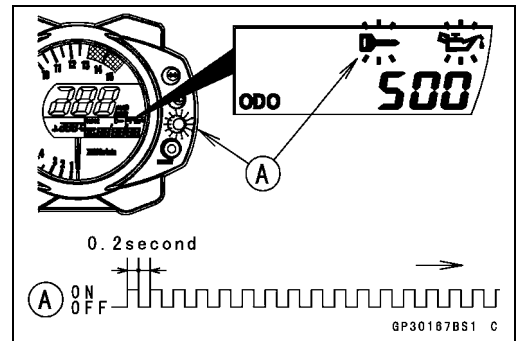
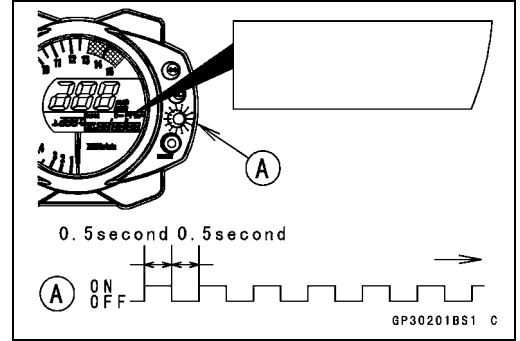

When Registered User Key is Inserted.

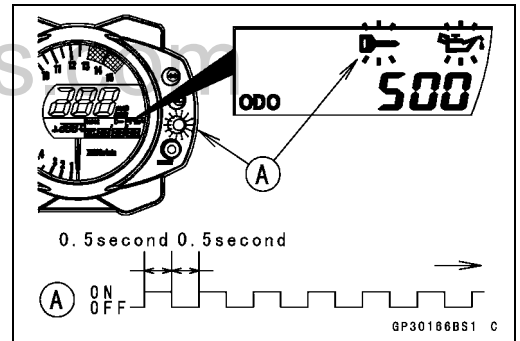

User Key Collation Error

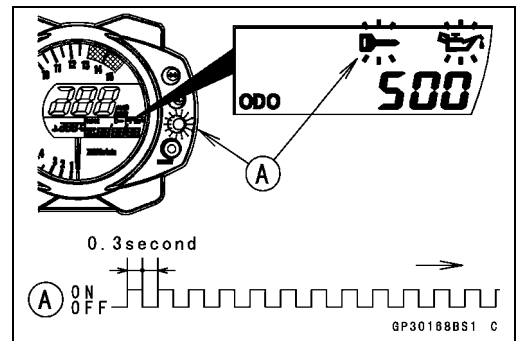

Immobilizer System (Equipped Models)

- The user key 2 is registered in the ECU.
- The warning indicator light (LED) and immobilizer warning symbol [A] blinks 3 times and stops for 1 second and then repeats this cycle.
- This procedure has registered the master key and 2 user keys.
- Continue with the procedure to register an additional 3 user keys.

NOTE

○ The ECU can store up the six key codes (master key × 1 and user key × 5).

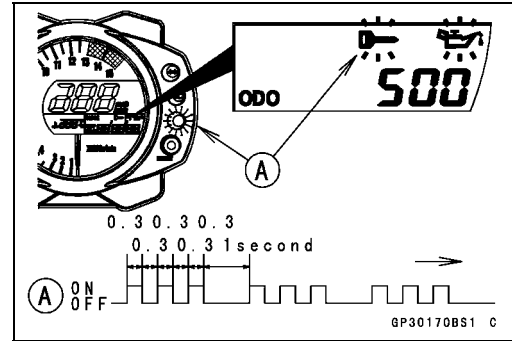

User Key Indicator Light and Symbol Flashes

	Indicator Light and Symbol Blinks	Indicator Light and Symbol Stop	Remarks
User Key 3	4 times	1 seconds	Repeat
User Key 4	5 times	1 seconds	Repeat
User Key 5	6 times	1 seconds	Repeat

- Turn OFF the ignition switch and wait for period of more than 15 seconds.
- The registration mode automatically ends.
- Warning indicator light (LED) goes off [A].

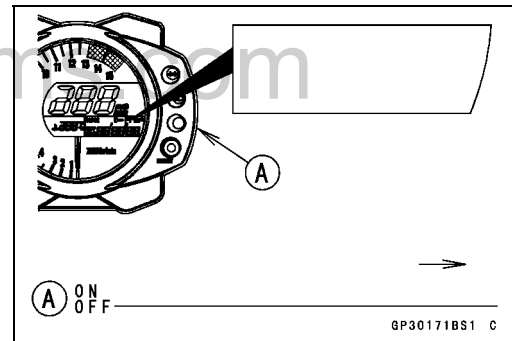

- Remove the key registration unit and connect the immobilizer/Kawasaki diagnostic system connector.

NOTE

○ Turn the ignition switch ON with the registered user key.
 ○ Check that the engine can be started using all registered user keys.

Immobilizer System (Equipped Models)

Spare User Key Registration Flow Chart

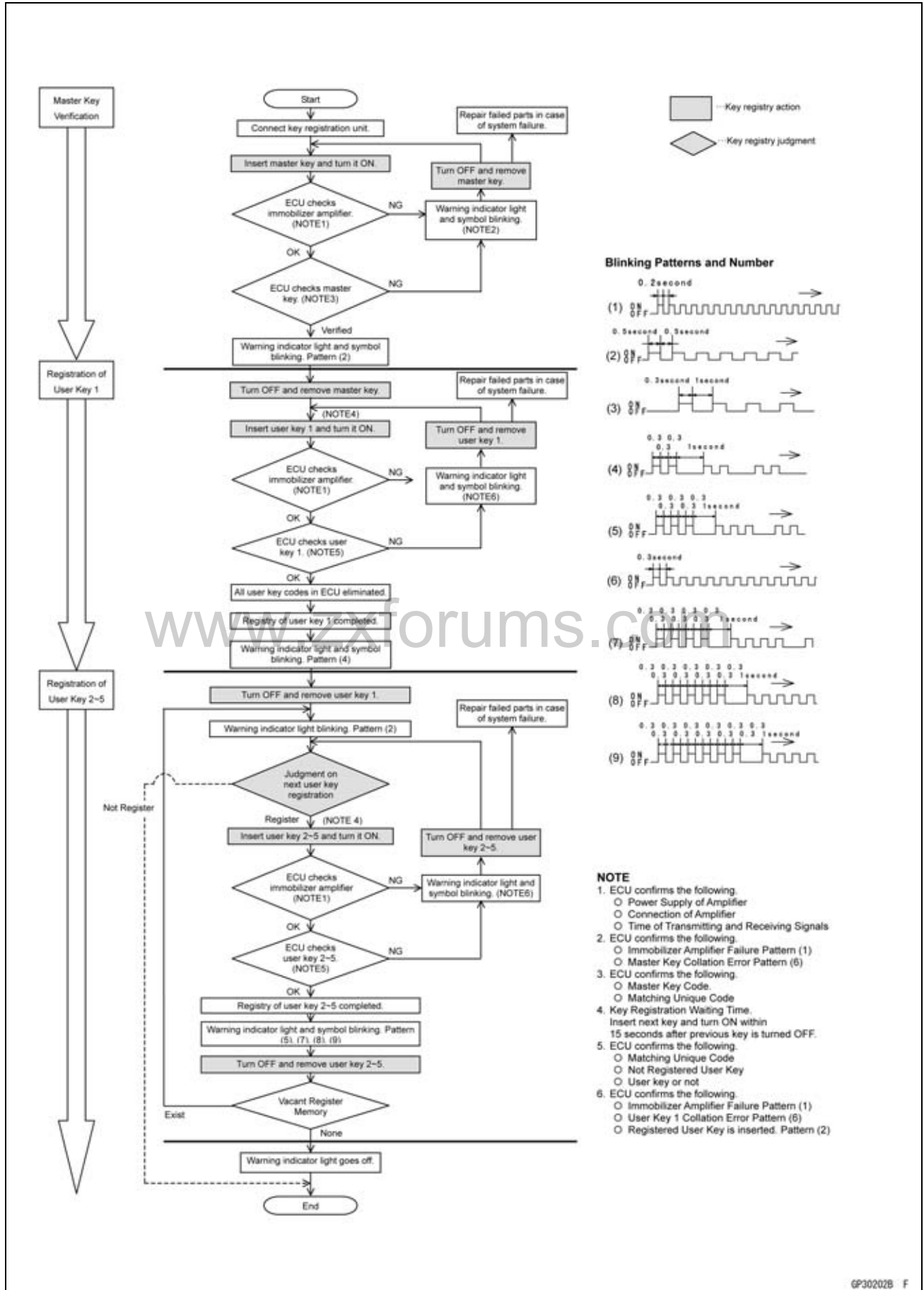

Immobilizer System (Equipped Models)

Case 2: When the ignition switch is faulty and to be replaced.

- Prepare a new ignition switch [A] and two new user keys [B].
- These parts are available as a set. Prepare the current master key [C].

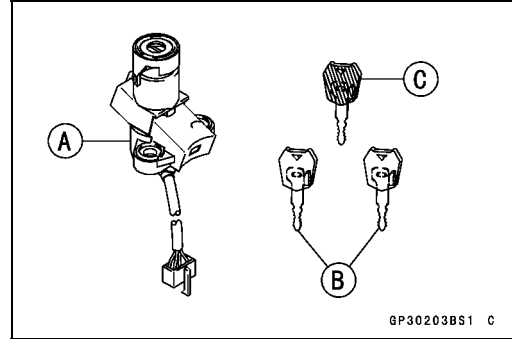

- Remove:
 - Ignition Switch and Immobilizer Antenna (see Immobilizer System Parts Replacement)
 - Front Seat (see Front Seat Removal in the Frame chapter)
 - Disconnect the immobilizer/Kawasaki diagnostic system connector.
 - Connect the key registration unit [A].
- Special Tool - Key Registration Unit: 57001-1582**



- Connect:
 - New Ignition Switch Lead Connector [A]
 - Immobilizer Antenna Lead Connector [B]

NOTE

○ Keep the antenna more than 15 cm from the ignition switch.

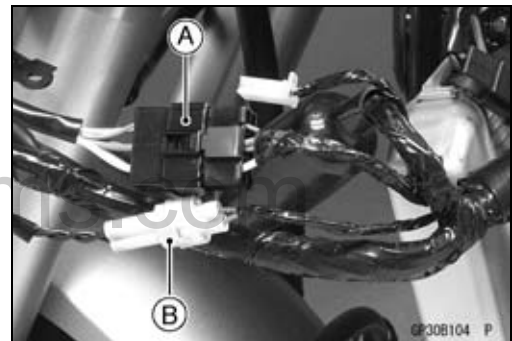

- Put the current master key [A] at the antenna [B]. Insert the new user key 1 [C] to the new ignition switch [D] and turn it ON.

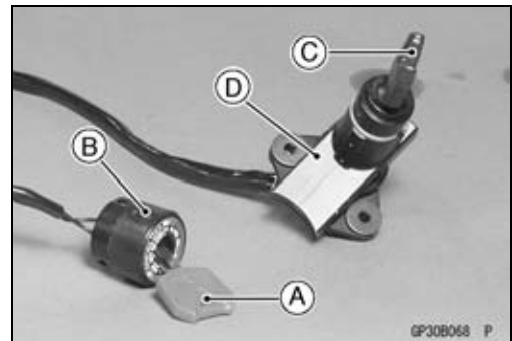

Verified

- The warning indicator light (LED) and immobilizer warning symbol [A] blinks to display the ECU is in the registration mode (go to the next step).

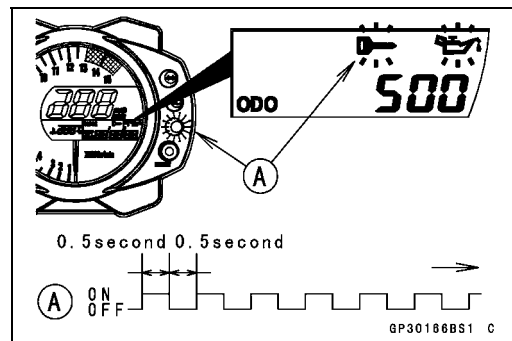

Immobilizer System (Equipped Models)

Not Verified

- The warning indicator light (LED) and immobilizer warning symbol [A] blinks to display the collation error.
Immobilizer Amplifier Failure

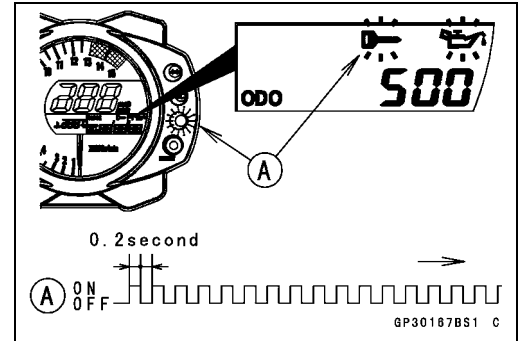

Master Key Collation Error

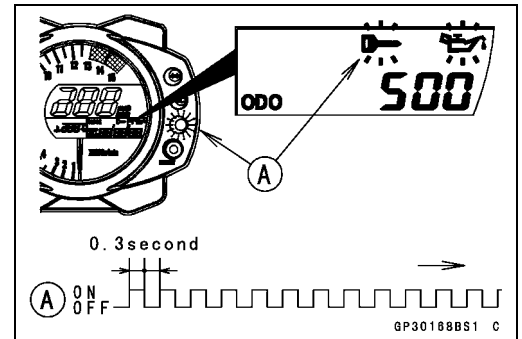

- Turn OFF and remove the new user key 1.
- Temporarily place the antenna [A] on the new ignition switch [B].
- Insert the user key 1 [C] again into the new ignition switch and turn it ON.

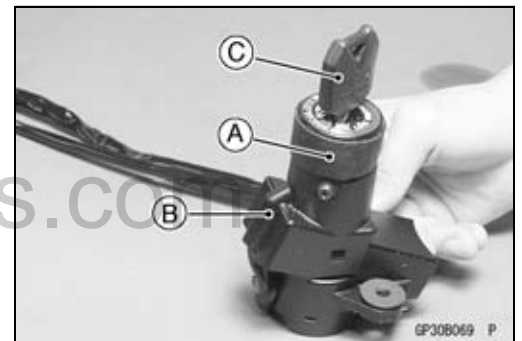

NOTE

- Place the antenna on the ignition switch, insert the next key and turn ON within 15 seconds after previous key is turned off and removed otherwise registration mode will be ended and the warning indicator light (LED) stops flashing.
- To return to the registration mode start the master key verification procedure. This applies to all user key registration.
- Keep other user keys away from the immobilizer antenna.

Immobilizer System (Equipped Models)

- If there is any problem in the registration, the warning indicator light (LED) and immobilizer warning symbol [A] blinks to display the collation error.
Immobilizer Amplifier Failure

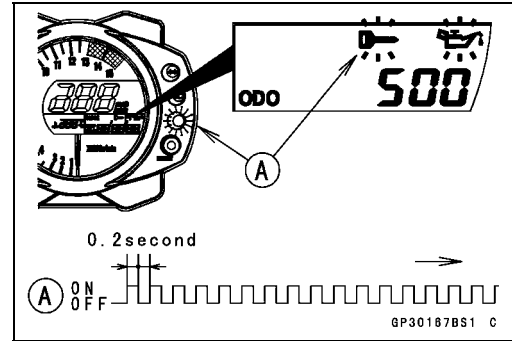

When Registered User Key is Inserted.

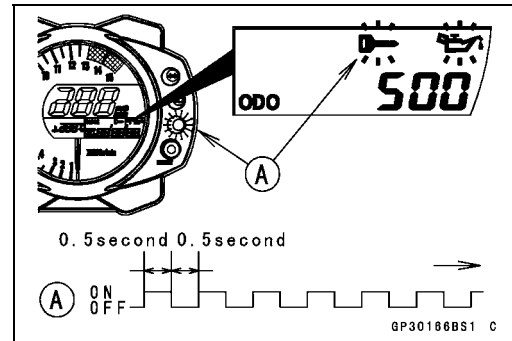

User Key Collation Error

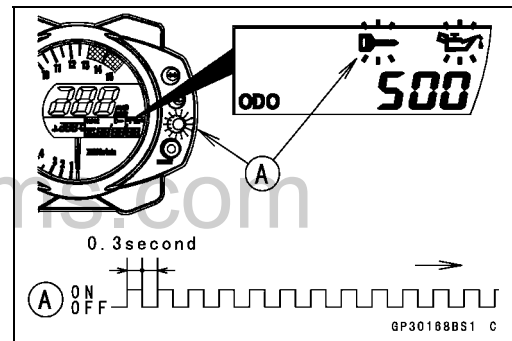

- The user key 1 is successfully registered in the ECU.
- The warning indicator light (LED) and immobilizer warning symbol [A] blinks 2 times and stops for 1 second and then repeats this cycle to indicate successful registering of user key 1.

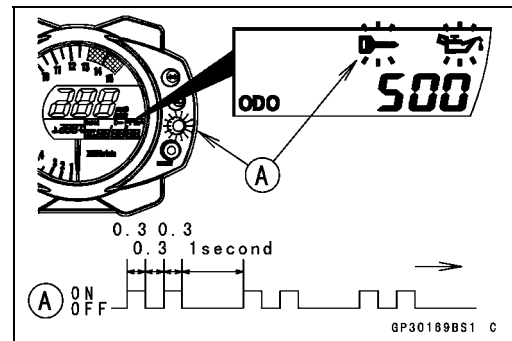

- Turn OFF and remove user key 1.
- The warning indicator light (LED) [A] blinks to display the registration mode.

NOTE

- Turn off the ignition switch and wait for the period more than 15 seconds. The registration mode automatically ends and warning indicator light (LED) goes off.
- This procedure has , registered the master key and one user key.
- Continue the procedure to program the second and later keys.

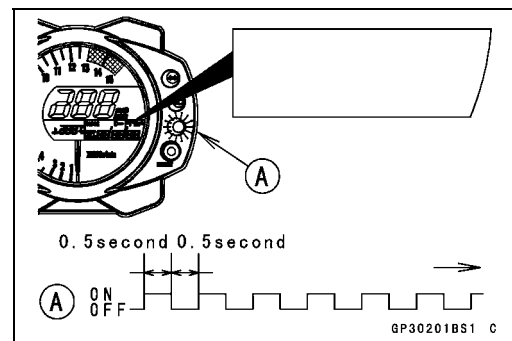

- Insert the user key 2 to the ignition switch and turn it ON.

Immobilizer System (Equipped Models)

- If there is any problem in the registration, the warning indicator light (LED) and immobilizer warning symbol [A] blinks to display the collation error.
Immobilizer Amplifier Failure

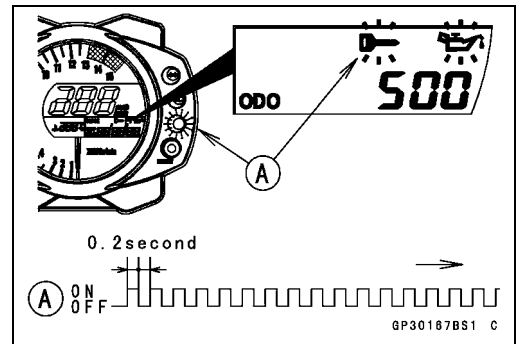

When Registered User Key is Inserted.

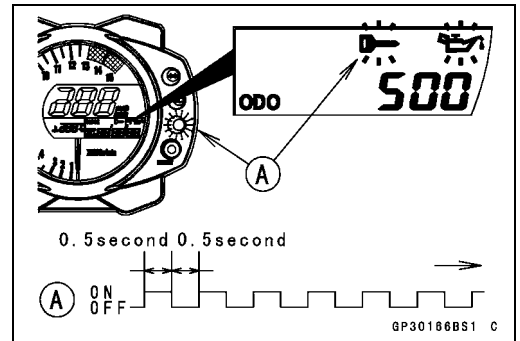

User Key Collation Error

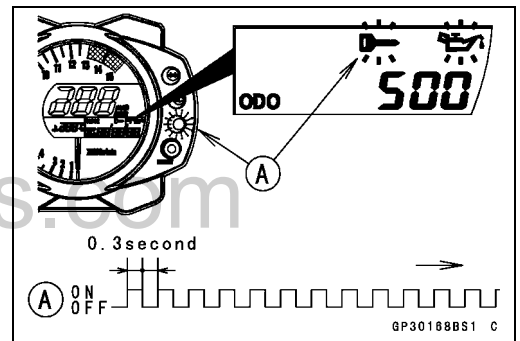

- The user key 2 is successfully registered in the ECU.
- The warning indicator light (LED) and immobilizer warning symbol [A] blinks 3 times and stops for 1 second and then repeat this cycle to indicate successful programming of user key 2.
- Turn OFF the ignition switch and wait for period more than 15 seconds.
- The registration mode automatically ends.

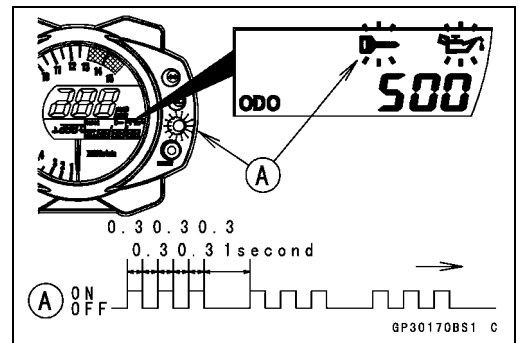

- Warning indicator light (LED) goes off [A].

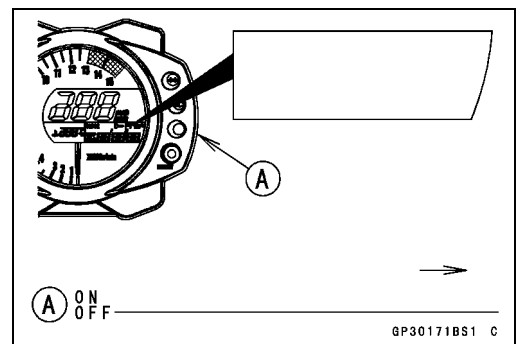

Immobilizer System (Equipped Models)

- Remove the key registration unit and connect the immobilizer/Kawasaki diagnostic system connector.

NOTE

- Turn the ignition switch ON with the registered user key.
- Check that the engine can be started using all registered user keys.

- Install the new ignition switch and antenna.

Case 3: When the electric control unit (ECU) is faulty and has to be replaced.

- Prepare a new ECU [A], current master key [B] and current user keys [C].

NOTE

- The key registration unit is not required.

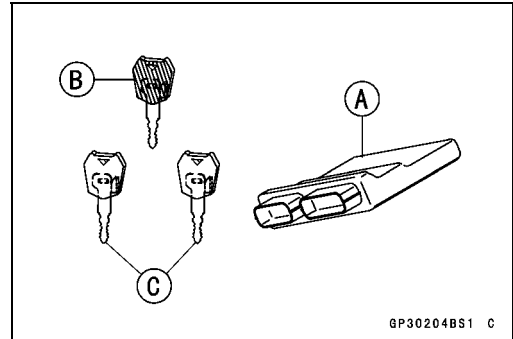

- Replace:
ECU [A] (see Immobilizer System Parts Replacement)



- Insert the current master key into the ignition switch and turn it ON.

- If there is any problem in the registration, the warning indicator light and immobilizer warning symbol [A] blinks to display the collation error.
Immobilizer Amplifier Failure

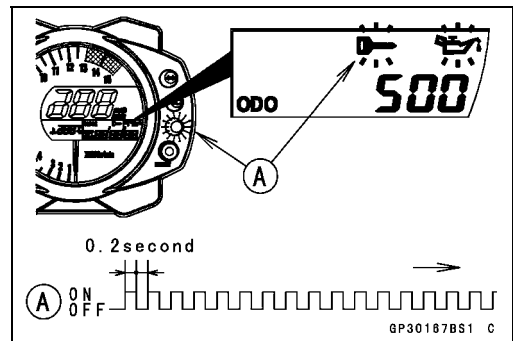

Master Key Collation Error

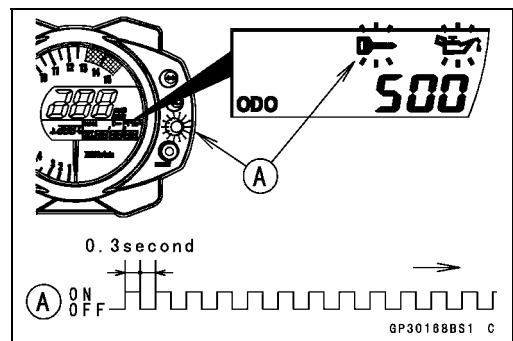

Immobilizer System (Equipped Models)

- The master key is registered in the ECU.
- The warning indicator light (LED) and immobilizer warning symbol [A] blinks 1 time and stops for 1 second and the repeats this cycle to indicate successful registration of the master key.

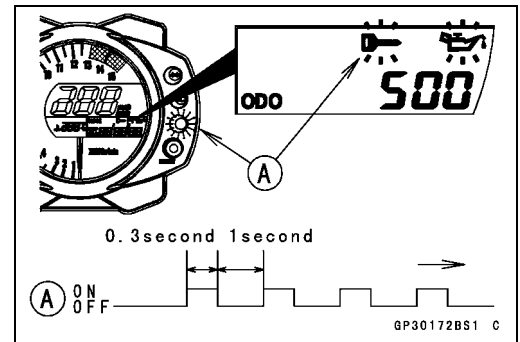

- Turn OFF the master key and remove it.
- The warning indicator light (LED) [A] blinks to display the registration mode.

NOTE

- Insert next key and turn ON within 15 seconds after previous key is turned off and removed otherwise registration mode will be ended and the warning indicator light (LED) goes off.
- To return to the registration mode start the master key verification procedure. This applies to all user key registration.

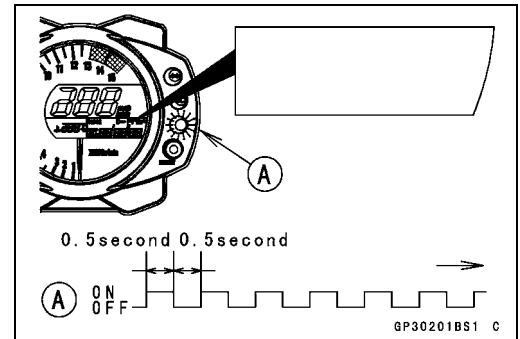

- Insert the user key 1 to the ignition switch and turn it ON.

NOTE

- Keep the other user keys away from the immobilizer antenna.

- If there is any problem in the registration, the warning indicator light (LED) and immobilizer warning symbol [A] blinks to display the collation error.
Immobilizer Amplifier Failure

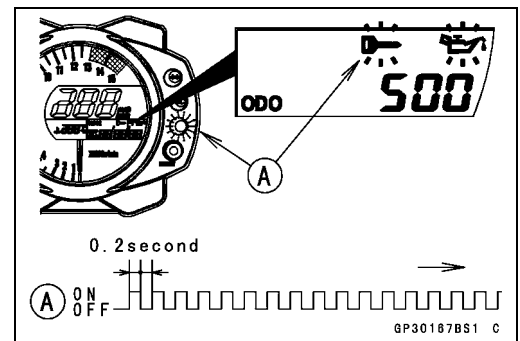

When Registered User Key is Inserted.

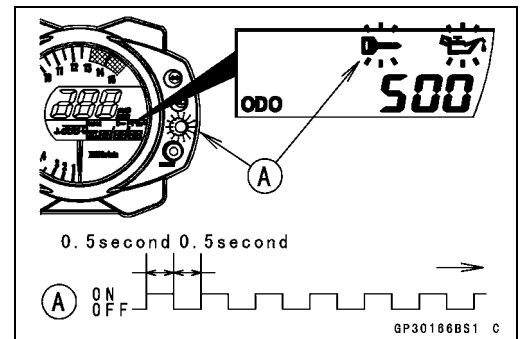

Immobilizer System (Equipped Models)

User Key Collation Error

- The user key 1 is registered in the ECU.
- The warning indicator light (LED) and immobilizer warning symbol [A] blinks 2 times and stops for 1 second and then repeats this cycle to indicate successful registration of user key.

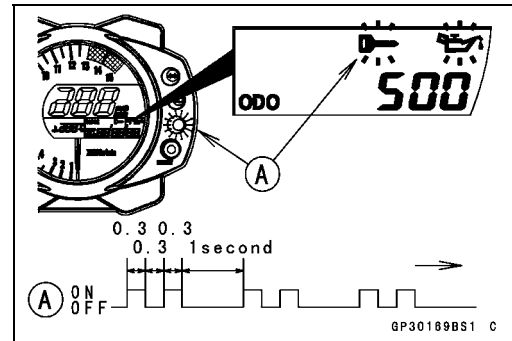
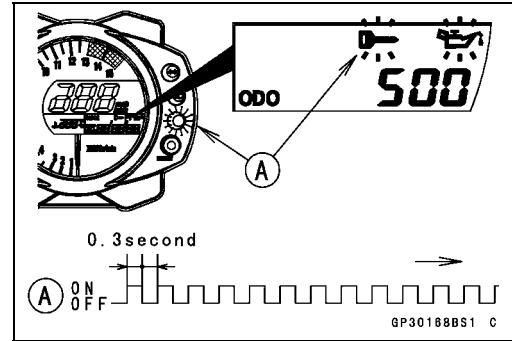

- Turn OFF and remove the user key 1.
- The warning indicator light (LED) [A] blinks to display the registration mode codes.

NOTE

- Insert next key and turn ON within 15 seconds after previous key is turned off and removed otherwise registration mode will be ended and the warning indicator light goes off.
- To return to the registration mode start the master key verification procedure. This applies to all user key registration.

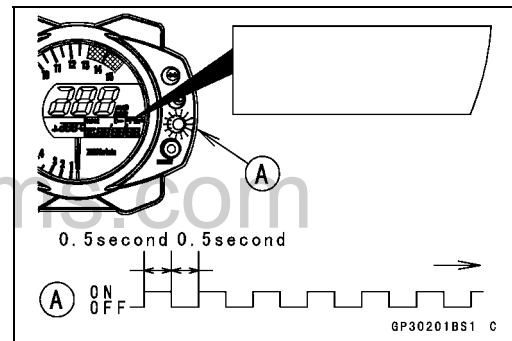

- Insert the user key 2 to the ignition switch and turn it ON.
- If there is any problem in the registration, the warning indicator light (LED) and immobilizer warning symbol [A] blinks to display the collation error code. Immobilizer Amplifier Failure

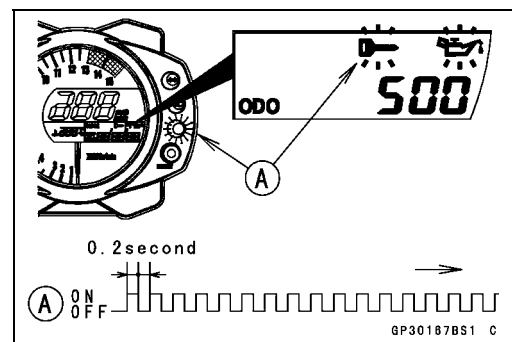

Immobilizer System (Equipped Models)

When Registered User Key is Inserted.

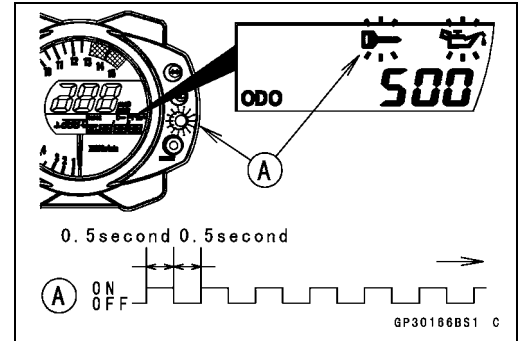

User Key Collation Error

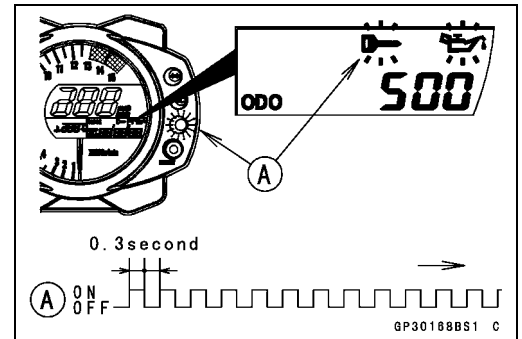

- The user key 2 is registered in the ECU.
- The warning indicator light (LED) and immobilizer warning symbol [A] blinks 3 times and stops for 1 second and then repeats this cycle to indicate successful registration of user key 2.
- Turn OFF the ignition switch and wait for period more than 15 seconds.
- The registration mode automatically ends.

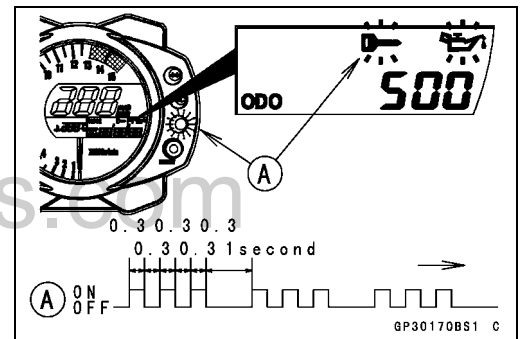

- Warning indicator light (LED) goes off [A].

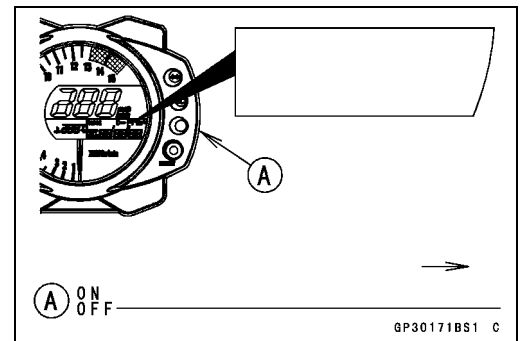

NOTE

- Turn the ignition switch ON with the registered user key.
- Check that the engine can be started using all registered user keys.

Case 4: When master key is faulty or lost.

The master key replacement is considered very rare case. However if it is required, the following is necessary.

NOTE

- The ECU must be replaced with a new one because the master key code that is registered in the current ECU can not be rewritten.

Immobilizer System (Equipped Models)

- Prepare a new ECU [A], new master key [B] and current user keys [C].

NOTE

- The key registration unit is not required.
- The key registration process is same as the electric control unit replacement.

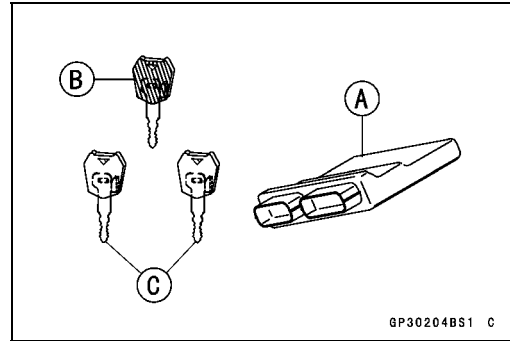
**Case 5: When replacing the antenna.**

- Prepare a new antenna.
- Refer to the Immobilizer System Parts Replacement.

NOTE

- No key registration is required.

Immobilizer System (Equipped Models)

All Keys Initial Registration Flow Chart

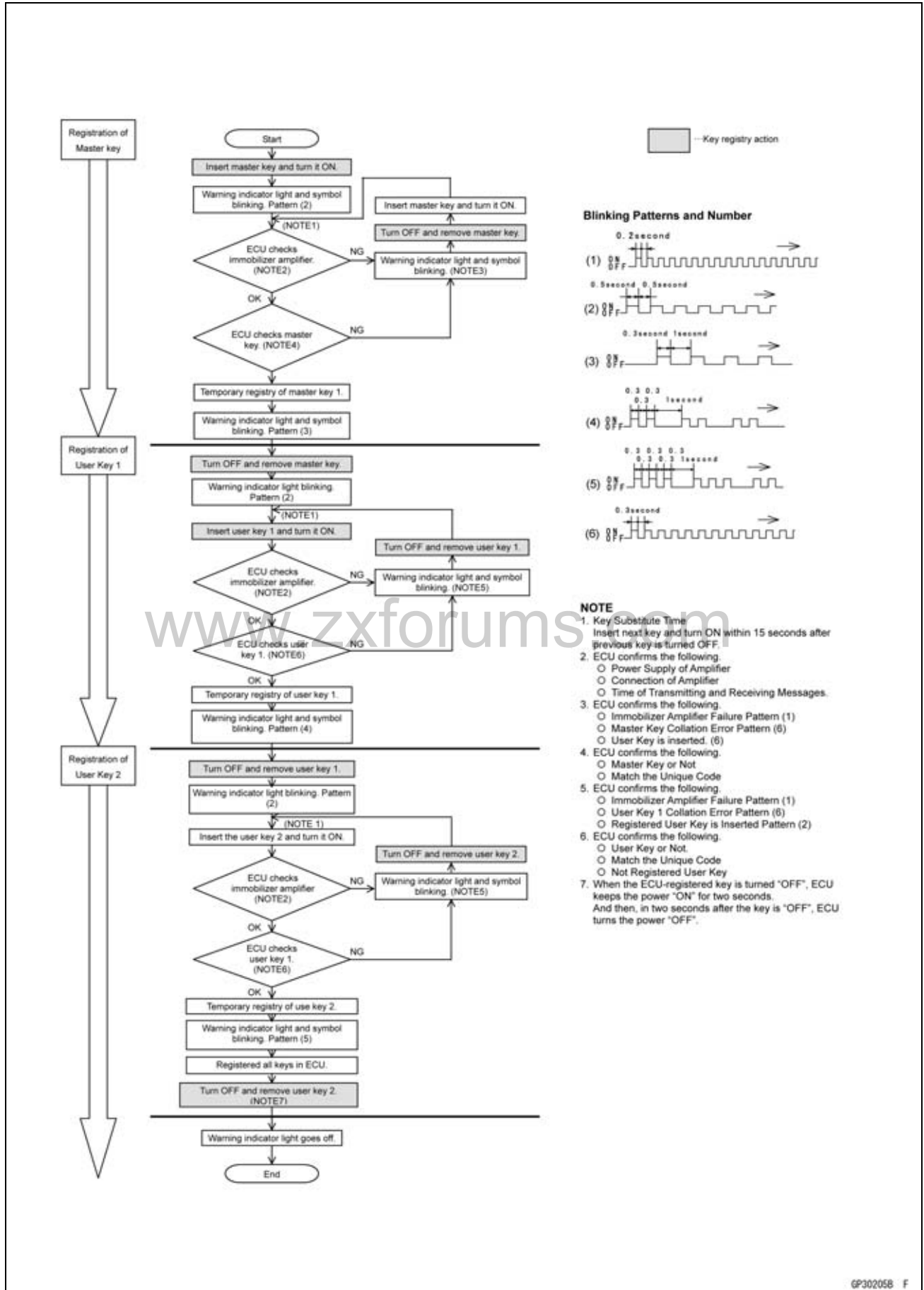

Immobilizer System (Equipped Models)

Immobilizer System Parts Replacement

Immobilizer Antenna

- Remove the left middle fairing (see Middle Faring Removal in the Frame chapter).
- Disconnect the lead connectors [A].

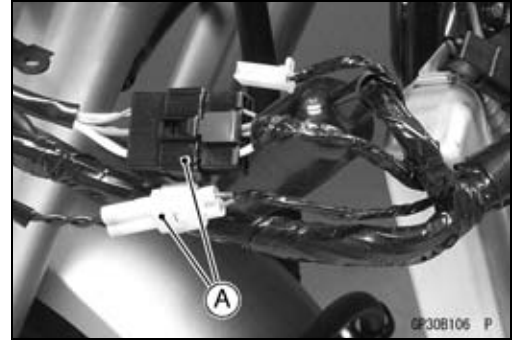

- Remove:
 - Steering Stem Head (see Stem, Stem Bearing Removal in the Steering chapter)
 - Handlebar (see Handlebar Removal in the Steering chapter)
- Using a small chisel or punch, turn out the Torx bolts [A].
- Remove the clamp [B].

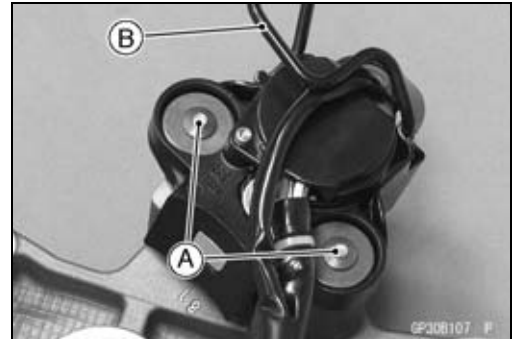

- Cut the band [A].
- Remove the screw [B].
- Remove the antenna [C] with the cover [D].
- Pull the lower parts [E] of the cover outside to clear the projection [F] of the ignition switch.

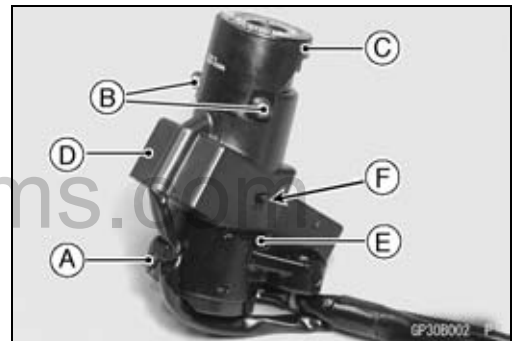

- Install the clamp.
- Tighten a new Torx bolt [A] until the bolt head [B] is broken [C].
- Run the leads correctly (see Cable, Wire, and Hose Routing section in the Appendix chapter).

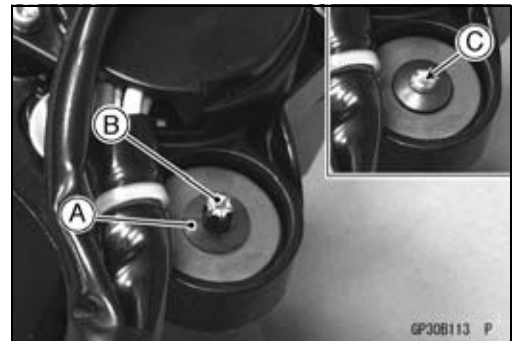

Immobilizer Amplifier Replacement

- Remove the left middle fairing (see Middle Fairing Removal in the Frame chapter).
- Disconnect the connector [A].
- Remove the amplifier [B] from the bracket [C].

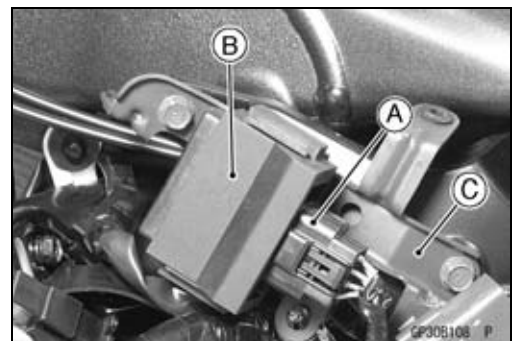

Immobilizer System (Equipped Models)

ECU (Electric Control Unit) Replacement (for Immobilizer Models)

- Remove:
 - Front Seat (see Front Seat Removal in the Frame chapter)
 - Relay Box [A]

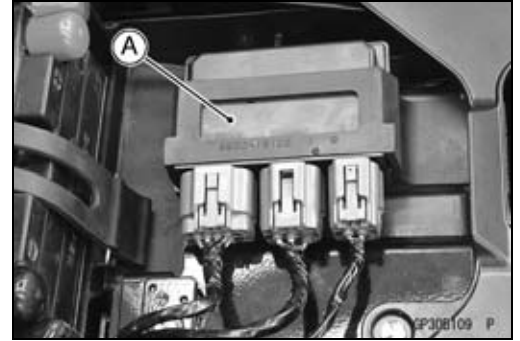

- Using a small chisel or other suitable tool, cut off the screws [A].
- Remove:
 - Upper Guard Bracket [B]
 - Lower Guard Bracket [C]

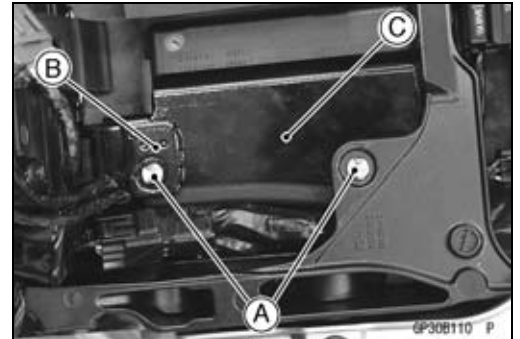

- Take out the ECU [A] and disconnect the connectors [B].

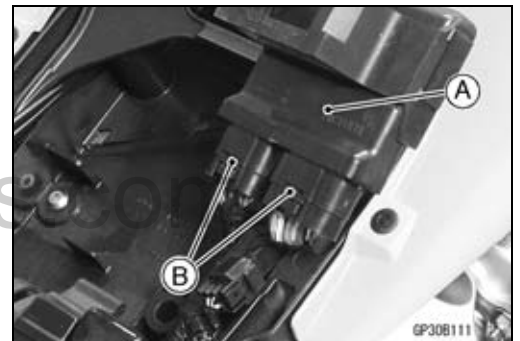

www.zxforums.com

- Connect the ECU connectors.
- Insert the slits of the rubber protector to the projections [A] of the rear fender front.

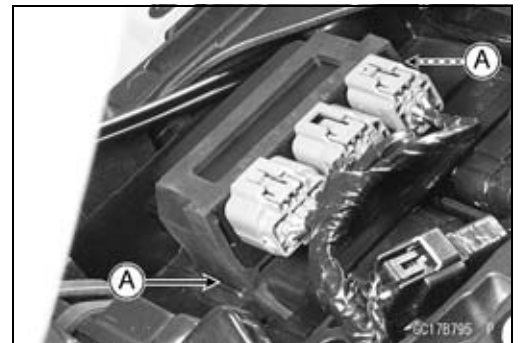

- Install the trim [A] to the lower guard bracket [B] as shown.

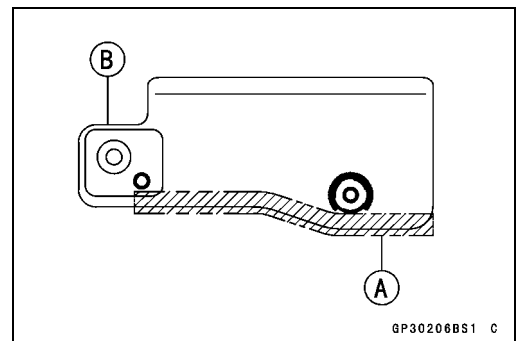

Immobilizer System (Equipped Models)

- Install:
 - Lower Guard Bracket [A]
 - Upper Guard Bracket [B]

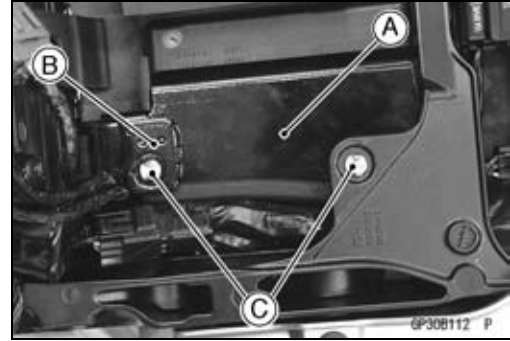

CAUTION

Do not pinch the leads.

- Tighten new screws [C] use Kawasaki genuine screws of which threads are coated with locking agent.

Immobilizer Relational Parts Replacement Chart

		Failed or Lost Part					
		Master Key (Red)	User Key (Black)	Ignition Switch	An-tenna	Ampli-fier	ECU
*	Master Key (Red)	●					
	User Key (Black)		●	○			
	Ignition Switch			●			
	An-tenna				●		
	Ampli-fier					●	
	ECU	○					●
*	Replacement Part						
●	Main Replacement Part						
○	Additional Replacement Part						

Immobilizer System Inspection

- Refer to the Immobilizer Amplifier and Blank Key Detection section in Fuel System (DFI) chapter (see Immobilizer Amplifier and Blank Key Detection section in Fuel System (DFI) chapter).

Immobilizer System (Equipped Models)

Immobilizer System Circuit

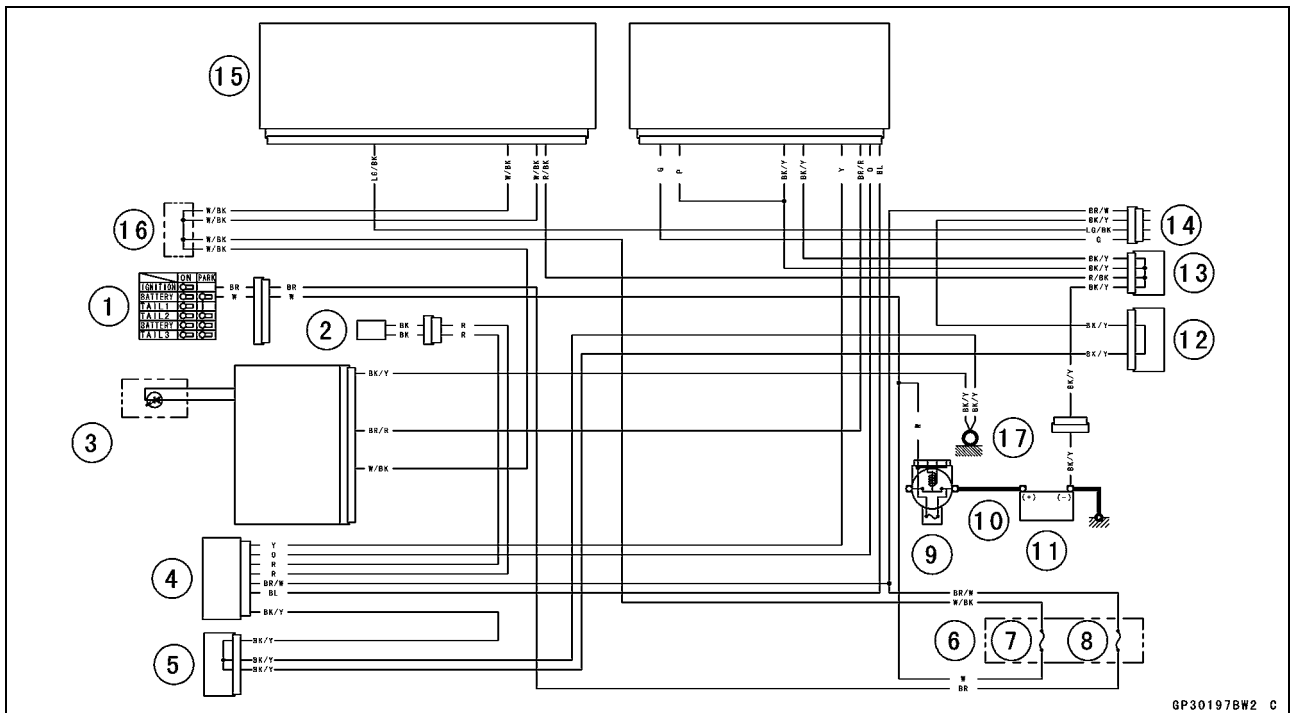

GP30197BW2 C

1. Ignition Switch
2. Immobilizer Antenna
3. Meter Unit
4. Immobilizer Amplifier
5. Joint Connector 1
6. Fuse Box
7. ECU Fuse 15 A
8. Ignition Fuse 15 A
9. Main Fuse 30 A
10. Starter Relay
11. Battery 12 V 10 Ah
12. Joint Connector 2
13. Joint Connector 3
14. Immobilizer/Kawasaki Diagnostic System Connector
15. ECU
16. Water-proof Joint 1
17. Frame Ground

Switches and Sensors

Brake Light Timing Inspection

- Refer to the Brake Light Switch Operation Inspection in the Periodic Maintenance chapter (see Brake Light Switch Operation Inspection in the Periodic Maintenance chapter).

Brake Light Timing Adjustment

- Refer to the Brake Light Switch Operation Inspection in the Periodic Maintenance chapter (see Brake Light Switch Operation Inspection in the Periodic Maintenance chapter).

Switch Inspection

- Using a hand tester, check to see that only the connections shown in the table have continuity (about zero ohms).
- For the switch housings and the ignition switch, refer to the tables in the Wiring Diagram.
- ★ If the switch has an open or short, repair it or replace it with a new one.

Special Tool - Hand Tester: 57001-1394

Rear Brake Light Switch Connections

Rear Brake Light Switch Connections		
Color	BR	BL
When brake pedal is pushed down	○ —	○ —
When brake pedal is released		

Sidestand Switch Connections

Sidestand Switch Connections		
Color	BK	G
When sidestand is down		
When sidestand is up	○ —	○ —

Oil Pressure Switch Connections*

Oil Pressure Switch Connections *		
Color	SW. Terminal	Ground
When engine is stopped	○ —	○ —
When engine is running		

*: Engine lubrication system is in good condition.

Switches and Sensors

Water Temperature Sensor Inspection

- Remove the water temperature sensor (see Removal/Installation in the Fuel System (DFI) chapter).
- Suspend the sensor [A] in a container of coolant so that the temperature-sensing projection [E] and threaded portion [E] are submerged.
- Suspend an accurate thermometer [B] in the coolant.

NOTE

- The sensor and thermometer must not touch the container side or bottom.
- Place the container over a source of heat and gradually raise the temperature of the coolant while stirring the coolant gently.
- Using the hand tester, measure the internal resistance of the sensor.
- The sensor sends electric signals to the ECU and coolant temperature gauge in the meter unit.
- Measure the resistance across the terminals and the body (for the gauge) at the temperatures shown in the table.
- ★ If the hand tester does not show the specified values, replace the sensor.

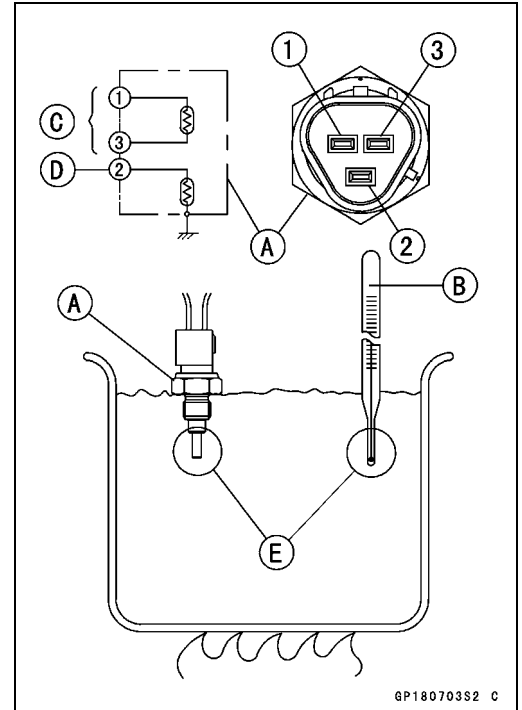

Water Temperature Sensor

Resistance for ECU [C]	
Temperature	Resistance (kΩ) (Terminal [1]-[3])
20°C (68°F)	2.46 +0.115 -0.143
80°C (176°F)	0.32 ±0.011
110°C (230°F)	0.1426 ±0.0041

Resistance for Water Temperature Gauge [D]	
Temperature	Resistance (Ω) (Terminal [2]-Body)
50°C (122°F)	210 ±40
120°C (248°F)	21.2 ±1.5

Speed Sensor Removal

- Drain the coolant (see Coolant Change in the Periodic Maintenance chapter).
- Remove:
 - Engine Sprocket Cover (see Engine Sprocket Removal in the Final Drive chapter)
 - Water Hose [A]



Switches and Sensors

- Disconnect the connector [A].

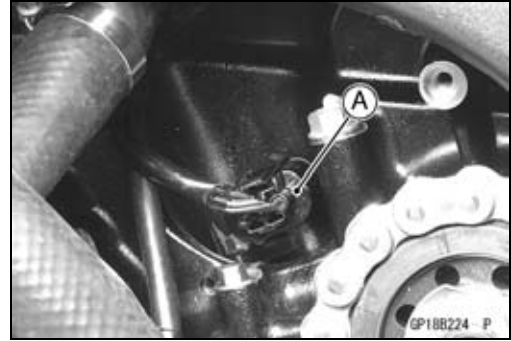

- Remove:
Bolt [A]
Speed Sensor [B]

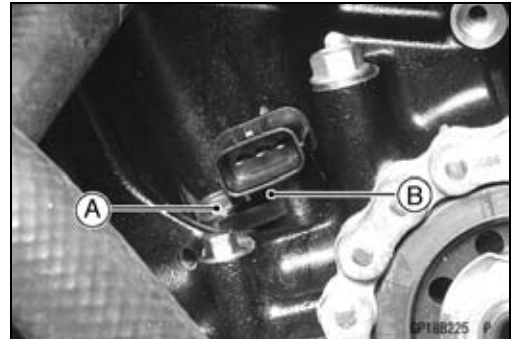

Speed Sensor Installation

- Apply grease to the new O-ring [A].
- Set the speed sensor bolt [B].
- Tighten:
Torque - Speed Sensor Bolt: 10 N·m (1.0 kgf·m, 89 in·lb)
- Install the removed parts (see appropriate chapters).

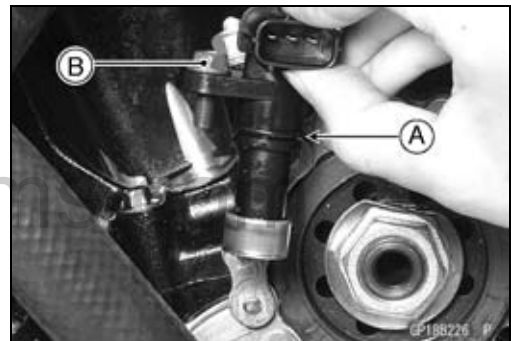

Speed Sensor Inspection

- Refer to the Speed Sensor section in the Fuel System (DFI) chapter (see Speed Sensor section in the Fuel System (DFI) chapter).

Fuel Reserve Switch Inspection

- Fill the fuel tank with fuel.
- Close the fuel tank cap surely.
- Remove the fuel tank (see Fuel Tank Removal in the Fuel System (DFI) chapter).
- Connect the test light [A] (12 V 3.4 W bulb in a socket with leads) and the 12 V battery [B] to the fuel pump connector [C].

Connections

- Battery (+) → 12 V 3.4 W Bulb (one side)
- 12 V 3.4 W Bulb (other side) → BK/R Lead Terminal
- Battery (-) → BK/W Lead Terminal

Special Tool - Needle Adapter Set: 57001-1457

- ★ If the test light turn on, the reverse switch is defective. Replace the fuel pump.

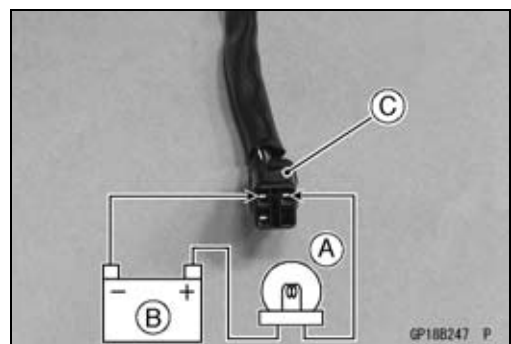

Switches and Sensors

- Remove the fuel pump (see Fuel Pump Removal in the Fuel System (DFI) chapter).
- Connect the test light (12 V 3.4 W bulb in a socket with leads) and the 12 V battery to the fuel pump connector as shown.

12 V Battery [A]

Test Light [B]

Fuel Pump Connector [C]

Fuel Reserve Switch [D]

- ★ If the test light doesn't light, replace the fuel pump.

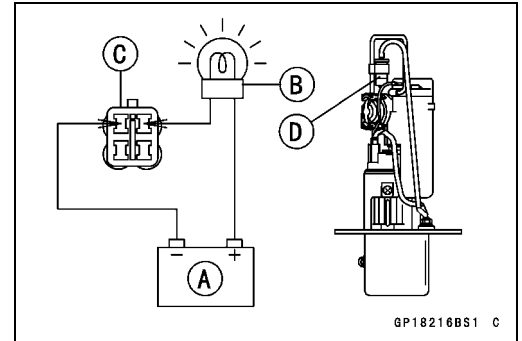

NOTE

- It may take a long time to turn on the test light in case that the fuel reserve switch is inspected just after the fuel pump is removed. Leave the fuel reserve switch with leads for inspection connected for few minutes.

Oxygen Sensor Removal (Europe Models)

NOTE

- The oxygen sensor itself is the same for #1 [A] and #2 [B], but wiring of the main harness side is different.

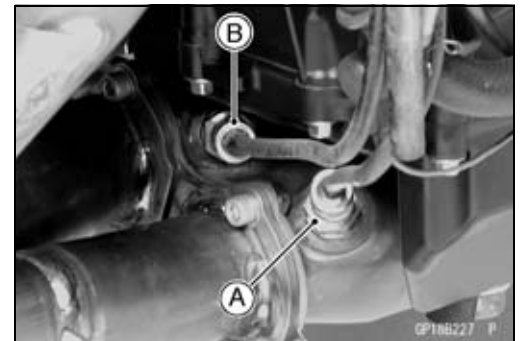

- Remove the left middle fairing (see Middle Fairing Removal in the Frame chapter).
- Disconnect:
 - Oxygen Sensor #1 Lead Connector [A]
 - Oxygen Sensor #2 Lead Connector [B]



- Remove the oxygen sensor #1 [A].



Switches and Sensors

- Remove:
 - Front Exhaust Pipe (see Front Exhaust Pipe Removal in the Engine Top End chapter)
 - Oxygen Sensor #2 [A]

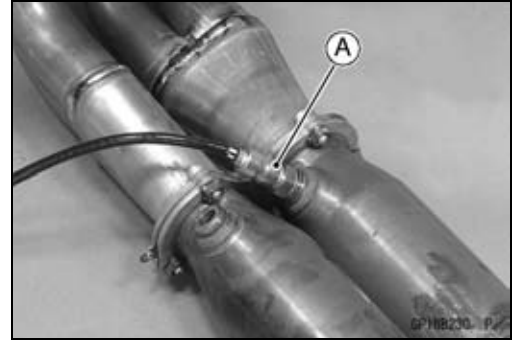

Oxygen Sensor Installation (Europe Models)

CAUTION

Never drop the oxygen sensor [A], especially on a hard surface. Such a shock to the unit can damage it. Do not touch the sensing part [B] to prevent oil contact. Oil contamination from hands can reduce sensor performance.

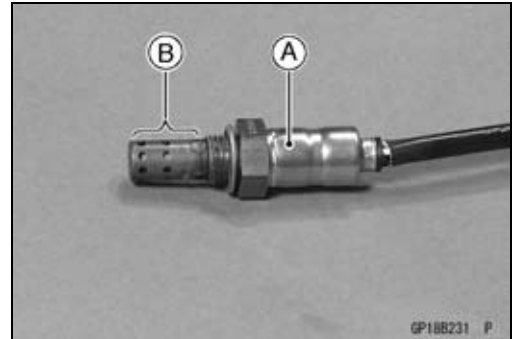

- Tighten:
 - Torque - Oxygen Sensors: 25 N·m (2.5 kgf·m, 18 ft·lb)
- Run the oxygen sensor leads correctly (see Cable, Wire, and Hose Routing section in the Appendix chapter).

Oxygen Sensor Inspection (Europe Models)

- Refer to the Oxygen Sensor #1/#2 Inspection in the Fuel System (DFI) chapter (see Oxygen Sensor #1/#2 Inspection in the Fuel System (DFI) chapter).

Oxygen Sensor Heater Inspection (Europe Models)

- Refer to the Oxygen Sensor Heater Inspection in the Fuel System (DFI) chapter (see Oxygen Sensor Heater Inspection in the Fuel System (DFI) chapter).

Gear Position Switch Removal

- Remove the lower fairings (see Lower Fairing Removal in the Frame chapter).
- Slide out the rubber boot [A].
- Loosen the oil pressure switch terminal bolt [B], and remove the switch lead [C].

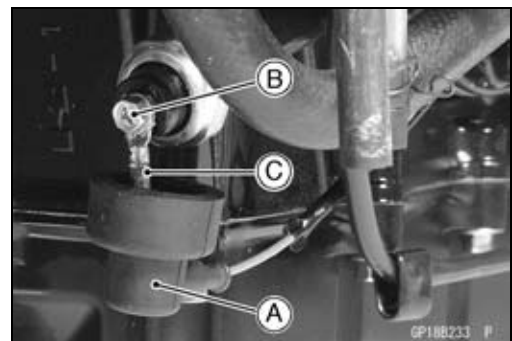

Switches and Sensors

- Remove:
 - Fuel Tank (see Fuel Tank Removal in the Fuel Tank Removal in the Fuel System (DFI) chapter)
 - Air Cleaner Housing (see Air Cleaner Housing Removal in the Fuel System (DFI) chapter)
- Disconnect:
 - Water Temperature Sensor Connector [A]
 - Gear Position Switch Lead Connector [B]



- Remove:
 - Water Pump (see Water Pump Removal in the Cooling System chapter)
 - Engine Sprocket Cover (see Engine Sprocket Removal in the Final Drive chapter)
- Disconnect the speed sensor connector [A].

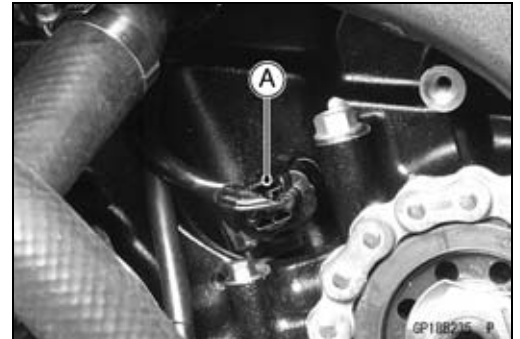

- Remove:
 - Screws [A]
 - Gear Position Switch [B]

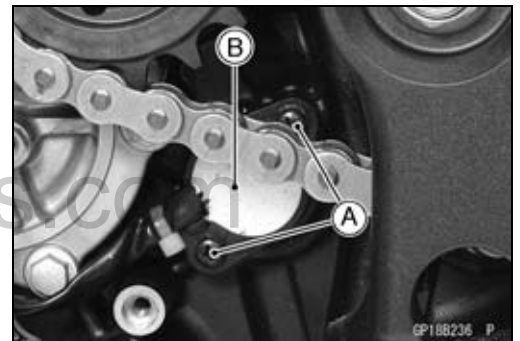

- Remove the pins [A] and springs from the shift drum.



Gear Position Switch Installation

- Securely place the springs [A] and pins [B] into the holes [C] of the shift drum.
- Apply grease to the new O-ring [D].
- Apply a non-permanent locking agent to the gear position switch screws.
- Tighten:

Torque - Gear Position Switch Screws: 3.0 N·m (0.31 kgf·m, 27 in·lb)

- Run the gear position switch, oil pressure switch, speed sensor and water temperature switch lead correctly (see Cable, Wire, and Hose Routing section in the Appendix chapter).

- Install the removed parts (see appropriate chapters).

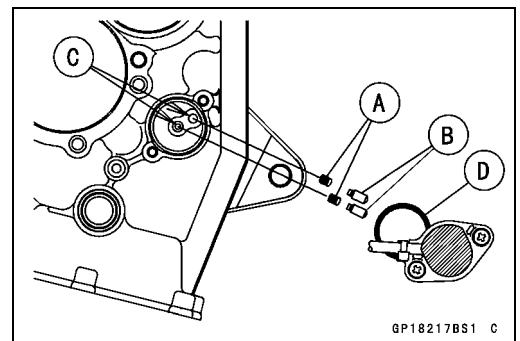

Switches and Sensors

Gear Position Switch Inspection

NOTE

○Be sure the transmission mechanism is good condition.

- Remove the fuel tank (see Fuel Tank Removal in the Fuel System (DFI) chapter).
- Disconnect the connector [A].

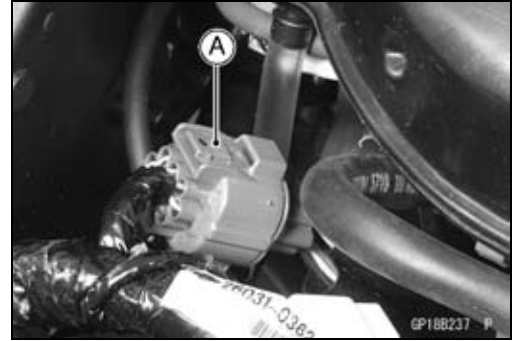

- Set the hand tester [A] to the 1 kΩ or × 100 Ω range and connect it to the terminals in the gear position switch lead connector [B] and ground.

- [C] Internal Circuit
- [1] Light Green Lead
- [2] Green/Red Lead
- [3] Black Lead

Special Tool - Hand Tester: 57001-1394

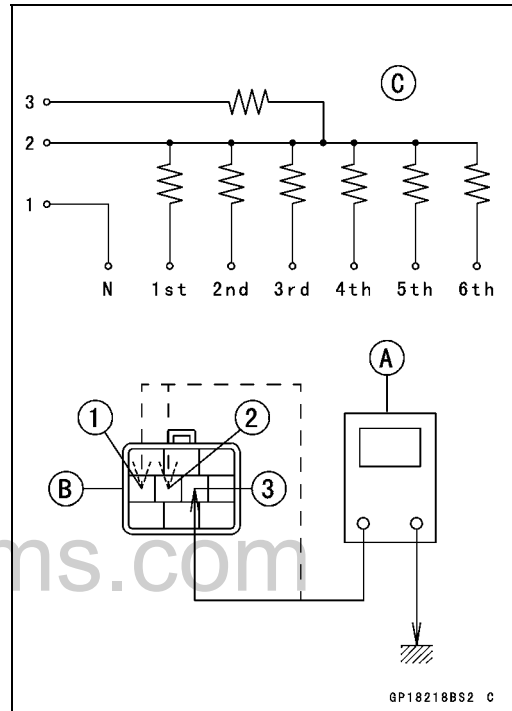

Gear Position Switch Resistance

kΩ

Gear Position	Connections		
	[1]-Ground	[2]-Ground	[3]-Ground
Neutral	about 0	—	—
1st	—	3.00 ~ 3.32	11.63 ~ 12.87
2nd	—	1.70 ~ 1.89	10.33 ~ 11.44
3rd	—	1.07 ~ 1.19	9.70 ~ 10.74
4th	—	0.695 ~ 0.769	9.32 ~ 10.32
5th	—	0.430 ~ 0.476	9.06 ~ 10.03
6th	—	0.248 ~ 0.274	8.89 ~ 9.81

★ If the tester reading is not as specified, replace the gear position switch with a new one.

Relay Box

The relay box [A] has relays and diodes. The relays and diodes can not be removed.

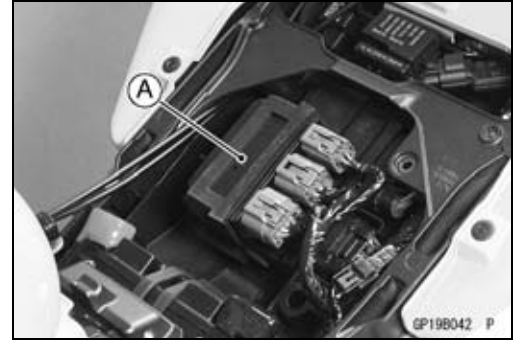

Relay Box Removal

- Remove the front seat (see Front Seat Removal in the Frame chapter).
- Take out the relay box [A] and disconnect the connectors [B].

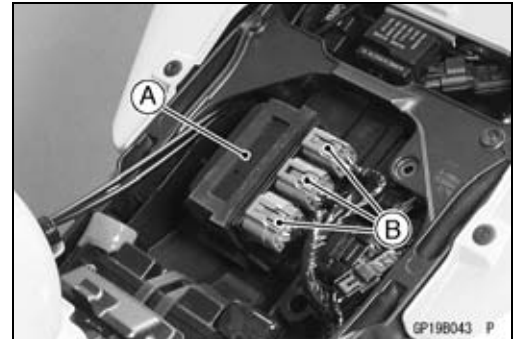

Relay Circuit Inspection

NOTE

○The ECU main relay function is included in the ECU.

- Remove the relay box (see Relay Box Removal).
- Check conductivity of the following numbered terminals by connecting the hand tester and one 12 V battery to the relay box as shown (see Relay Box Internal Circuit).
- ★ If the tester does not read as specified, replace the relay box.

Relay Circuit Inspection (with the battery disconnected)

	Tester Connection	Tester Reading (Ω)
Headlight Relay	1-3	∞
Fuel Pump Relay	4-5	∞
	6-7	Not ∞^*
Starter Circuit Relay	8-13	∞
	8-9	∞
Fan Relay	14-17	∞
	15-16	Not ∞^*

*: The actual reading varies with the hand tester used.

Relay Box

Relay Circuit Inspection (with the battery connected)

	Battery Connection (+) (-)	Tester Connection	Tester Reading (Ω)
Fuel Pump Relay	6-7	4-5	0
Fan Relay	15-16	14-17	0

	Battery Connection (+) (-)	Tester Connection DC 25 V Range	Tester Reading (V)
Starter Circuit Relay	13-9	8-9	Battery Voltage

(+): Apply positive lead.

(-): Apply negative lead.

Diode Circuit Inspection

- Remove the relay box (see Relay Box Removal).
- Check conductivity of the following pairs of terminals (see Relay Box Internal Circuit).

Diode Circuit Inspection

Tester Connection	1-8, 2-8, 9-10, 9-12, 9-13, 10-11, 10-12
-------------------	--

★ The resistance should be low in one direction and more than ten times as much in the other direction. If any diode shows low or high in both directions, the diode is defective and the relay box must be replaced.

NOTE

○ The actual meter reading varies with the meter or tester used and the individual diodes, but generally speaking, the lower reading should be from zero to one half the scale.

Relay Box

Relay Box Internal Circuit

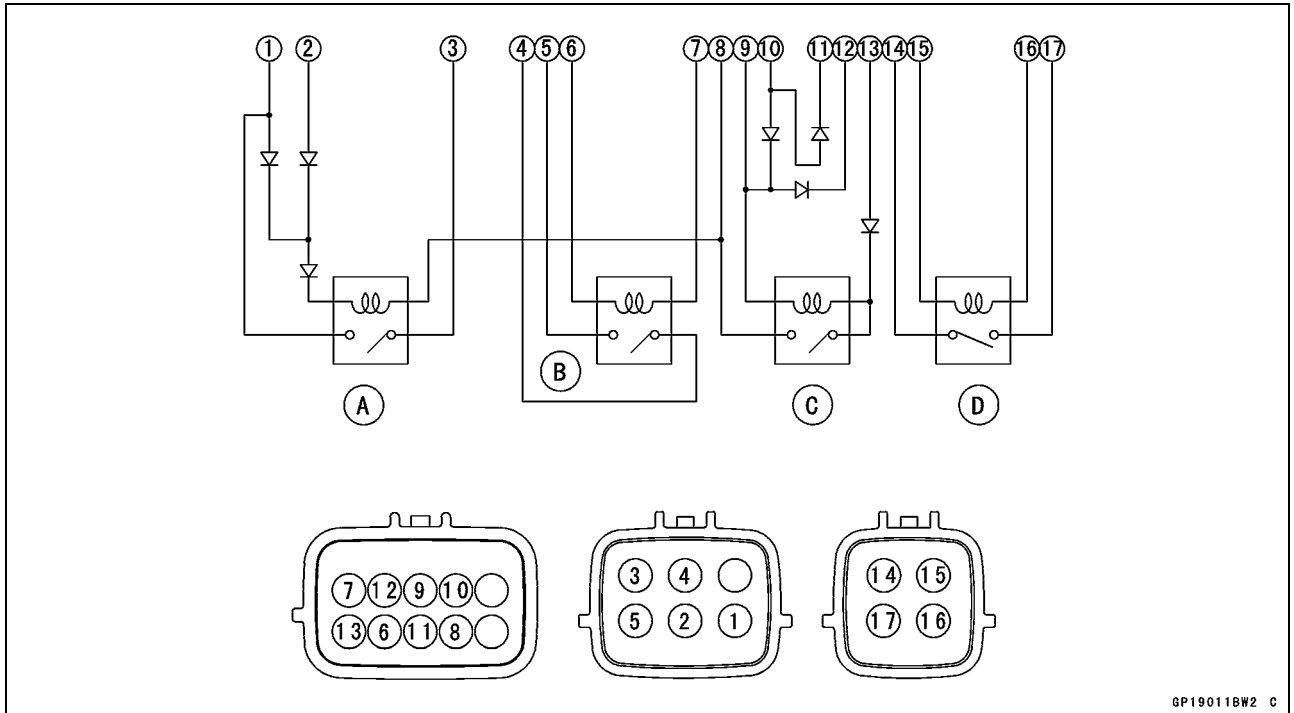

- A. Headlight Relay
- B. Fuel Pump Relay
- C. Starter Circuit Relay
- D. Fan Relay

www.zxforums.com

Fuse

30 A Main Fuse Removal

- Remove:
 - Front Seat (see Front Seat Removal in the Frame chapter)
 - Fuel Tank (see Fuel Tank Removal in the Fuel System (DFI) chapter)
 - 30 A Main Fuse Connector [A]

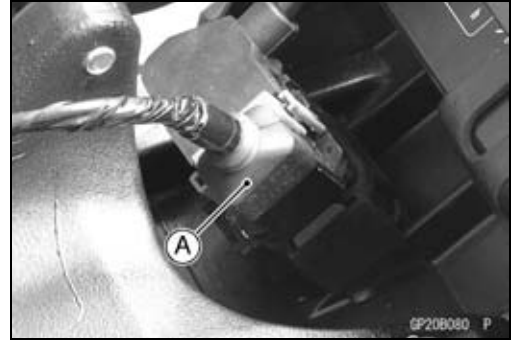

- Pull out the main fuse [A] from the starter relay with needle nose pliers.

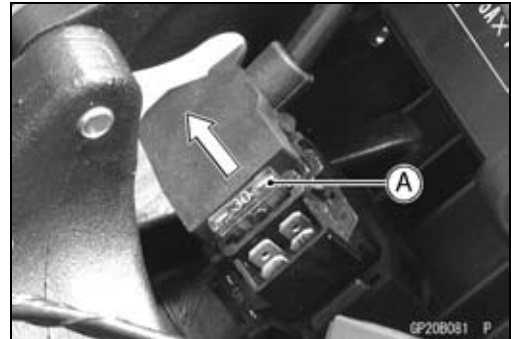

Fuse Box Fuse Removal

- Remove the front seat (see Front Seat Removal in the Frame chapter).
- Push the hook [A] to lift up the lid [B].

www.zxforums.com

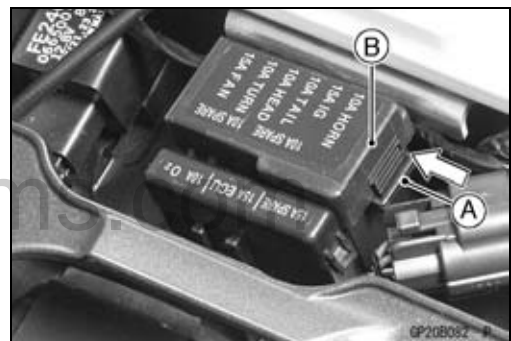

- Pull the fuses [A] straight out of the fuse box with needle nose pliers.



15 A ECU Fuse Removal

- Remove the front seat (see Front Seat Removal in the Frame chapter).
- Pull the hook [A] to lift up the lid [B]

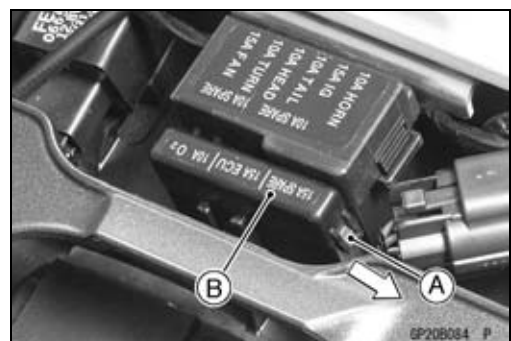

Fuse

- Pull the ECU fuse [A] straight out of the fuse box with needle nose pliers.

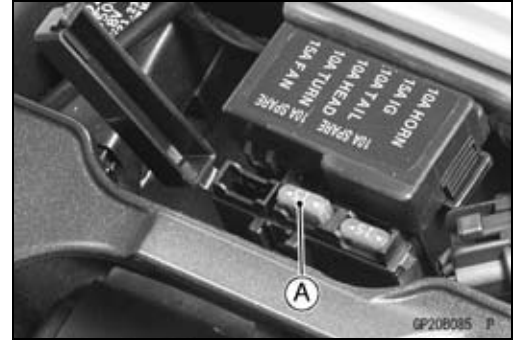

Fuse Installation

- ★ If a fuse fails during operation, inspect the electrical system to determine the cause, and then replace it with a new fuse of proper amperage.
- Install the junction box fuses on the original position as specified on the lid.

Fuse Inspection

- Remove the fuse (see Fuse Removal).
- Inspect the fuse element.
- ★ If it is blown out, replace the fuse. Before replacing a blown fuse, always check the amperage in the affected circuit. If the amperage is equal to or greater than the fuse rating, check the wiring and related components for a short circuit.

Housing [A]

Fuse Element [B]

Terminals [C]

Blown Element [D]

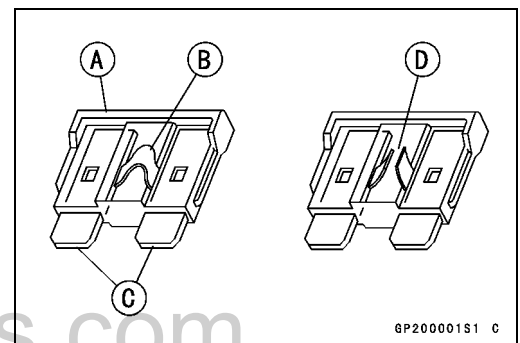

NOTE

- If a mass current flows to the battery which needs re-freshing charge when the engine is turned, the main fuse may be blown out.

CAUTION

When replacing a fuse, be sure the new fuse matches the specified fuse rating for that circuit. Installation of a fuse with a higher rating may cause damage to wiring and components.

www.zxforums.com

Appendix

Table of Contents

Cable, Wire, and Hose Routing	17-2
Troubleshooting Guide	17-30

www.zxforums.com

Cable, Wire, and Hose Routing

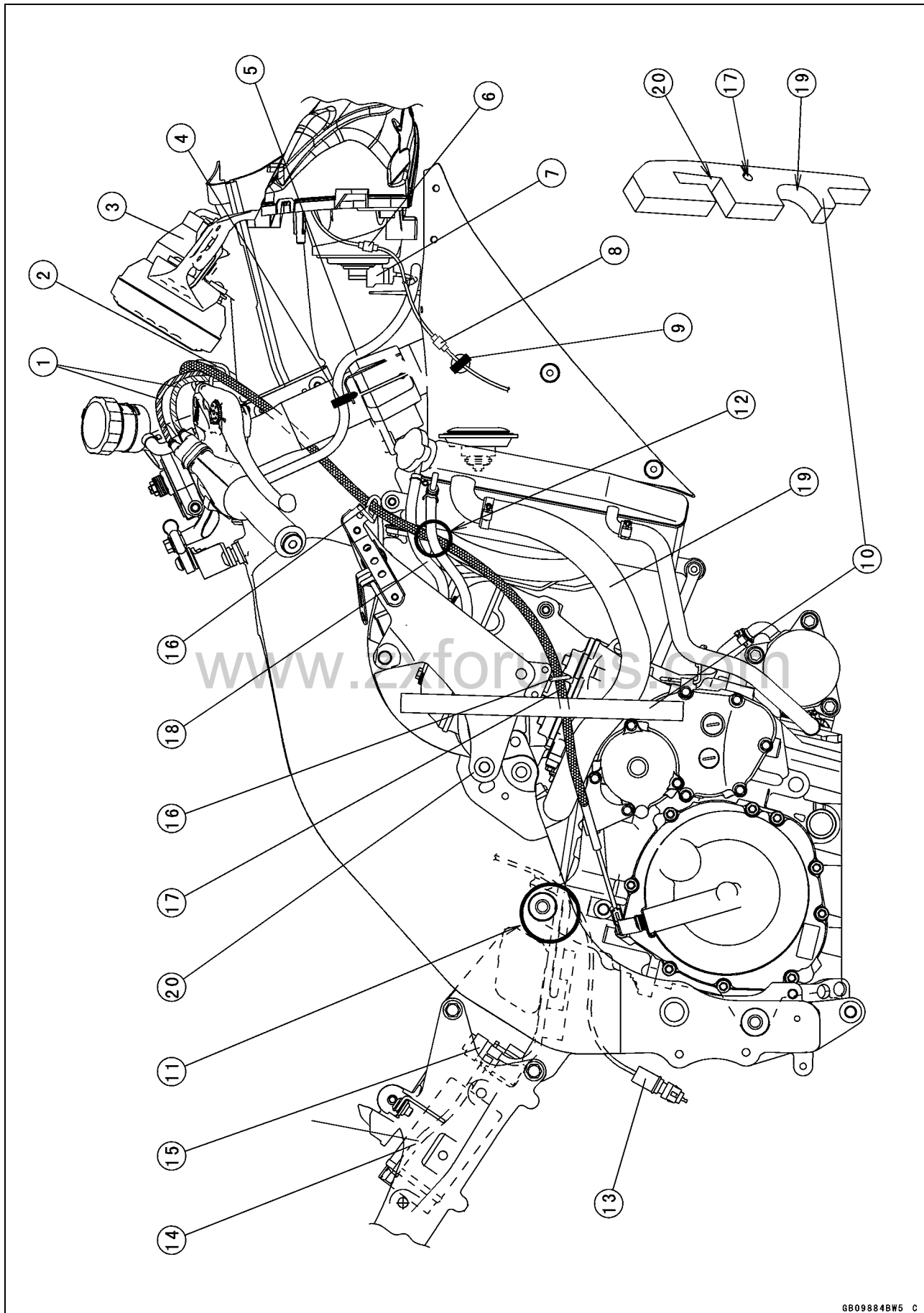

6B09884BW5 C

Cable, Wire, and Hose Routing

1. Throttle Cables
2. Clamp
3. Meter Connector
4. Clamp the right switch housing lead.
5. Right Switch Housing Lead
6. City Light Connector
7. Right Headlight Connector
8. Right Turn Signal Light Connector
9. Clamp the right turn signal light lead (Other than California Model only).
10. Heat Pad
11. Run the regulator/rectifier harness under the engine mount.
12. Run the clutch cable inside the radiator coolant return hose.
13. Rear Brake Light Switch
14. Battery Positive (+) Cable
15. Starter Relay
16. Clamp the clutch cable.
17. Clutch Cable
18. Radiator Overflow Hose
19. Radiator Hose
20. Engine Mount Bracket

www.zxforums.com

Cable, Wire, and Hose Routing

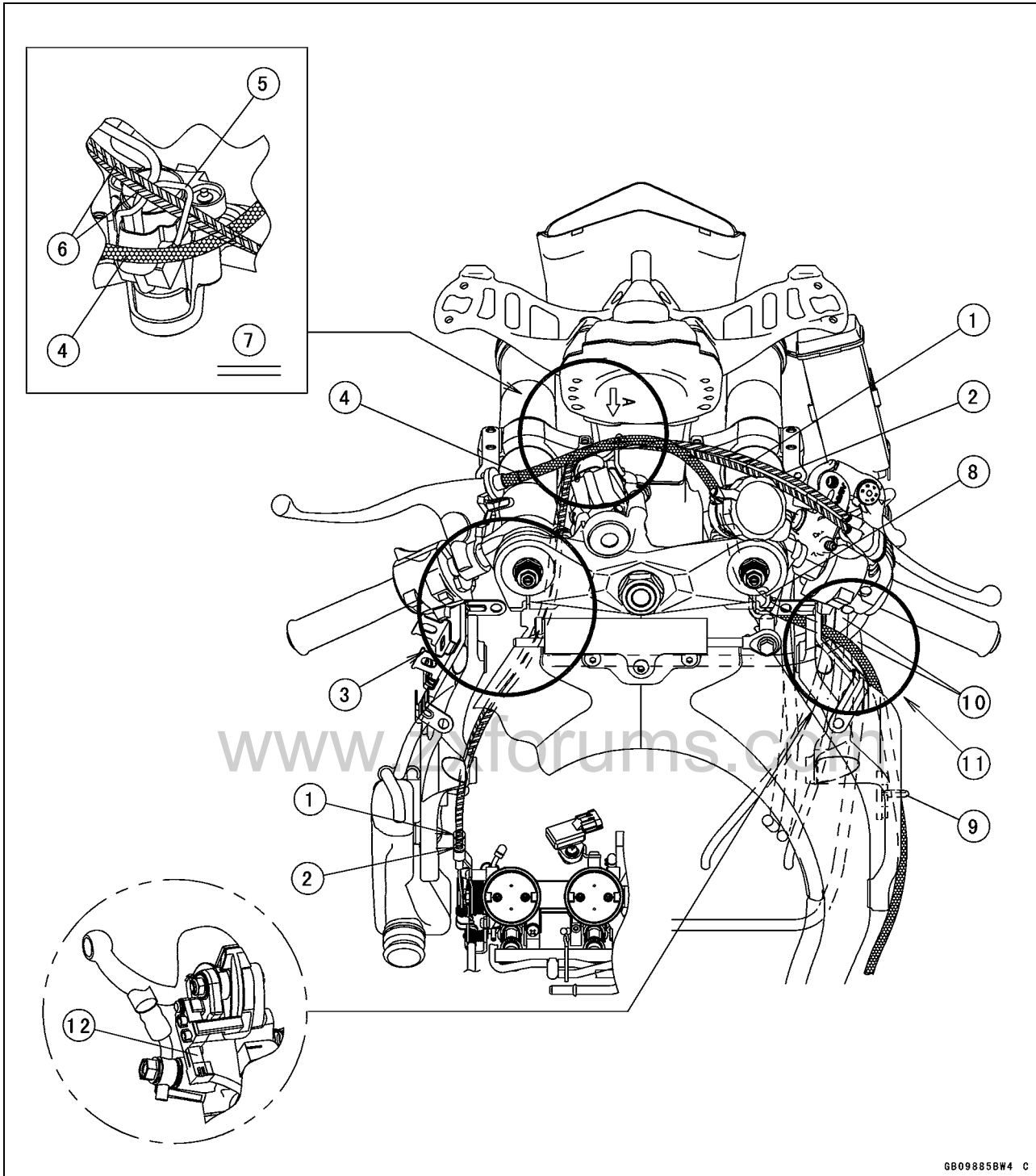

Cable, Wire, and Hose Routing

1. Throttle Cable (Accelerator)
2. Throttle Cable (Decelerator)
3. Run the throttle cables above the harness and hose, and under the ignition switch lead.
4. Clutch Cable
5. Clamp
6. Throttle Cables
7. Viewed A
8. Through the clutch cable into the bracket.
9. Through the clutch cable into the engine bracket.
10. Evaporative Hoses (California Model only)
11. Run the clutch cable above the evaporative hoses (California Model only).
12. Attend the distribution of the front brake light switch connector.

www.zxforums.com

Cable, Wire, and Hose Routing

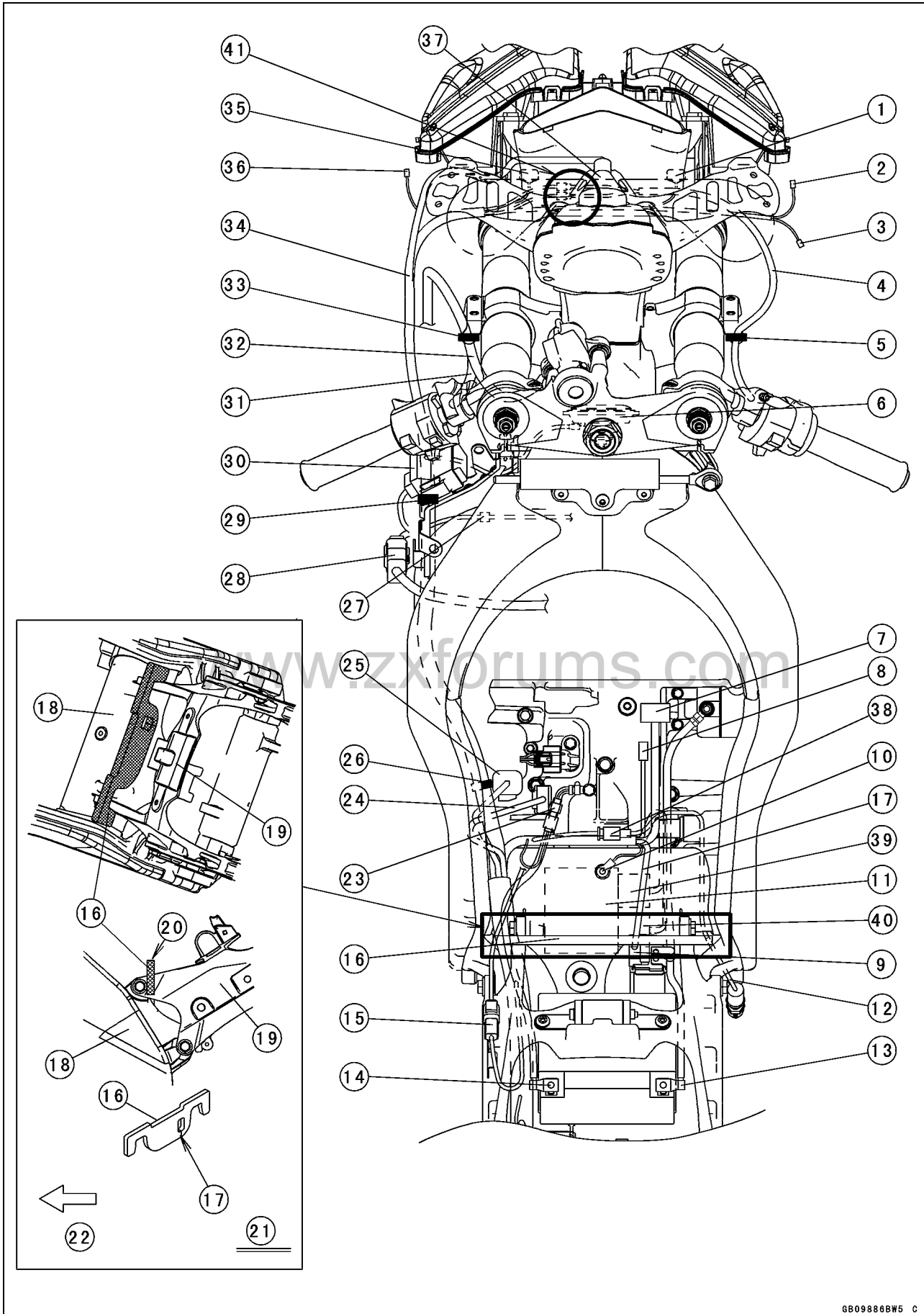

6B09886W5 C

Cable, Wire, and Hose Routing

1. Right Headlight Connector
2. Right City Light Connector
3. Right Turn Signal Light Connector
4. Right Switch Housing Lead
5. Clamp the right switch housing lead.
6. Horn
7. Engine Subharness Joint Connector (To the Throttle Assy)
8. Inlet Air Temperature Sensor (To the Air Cleaner Box)
9. Starter Relay
10. Frame Ground Lead
11. Regulator/Rectifier
12. Rear Brake Light Switch Lead
13. Battery Positive (+) Terminal
14. Battery Negative (-) Terminal
15. Clamp the fuel pump lead connector to the bracket.
16. Heat Pad
17. Starter Relay Lead
18. Front Frame
19. Rear Frame
20. Install the heat pad aligned with the bolt.
21. Viewed Left Side
22. Front
23. Battery Negative (-) Lead Connector
24. Alternator Lead
25. Engine Subharness Joint Connector
26. Clamp (The clamp attached on the main harness.)
27. Camshaft Position Sensor Connector
28. Joint Connector for the stick coil and air switching valve leads (Install it into the bracket.)
29. Clamp (The clamp attached on the main harness.)
30. Immobilizer Amplifier
31. Left Switch Housing Lead
32. Ignition Switch Lead
33. Clamp the left switch housing lead and ignition switch lead.
34. Main Harness
35. Left Headlight Connector
36. Left City Light Connector
37. Meter Connector
38. Rear Brake Light Switch Lead Connector
39. Gray
40. Black
41. Through the harnesses into the rib of the center inner fairing.

Cable, Wire, and Hose Routing

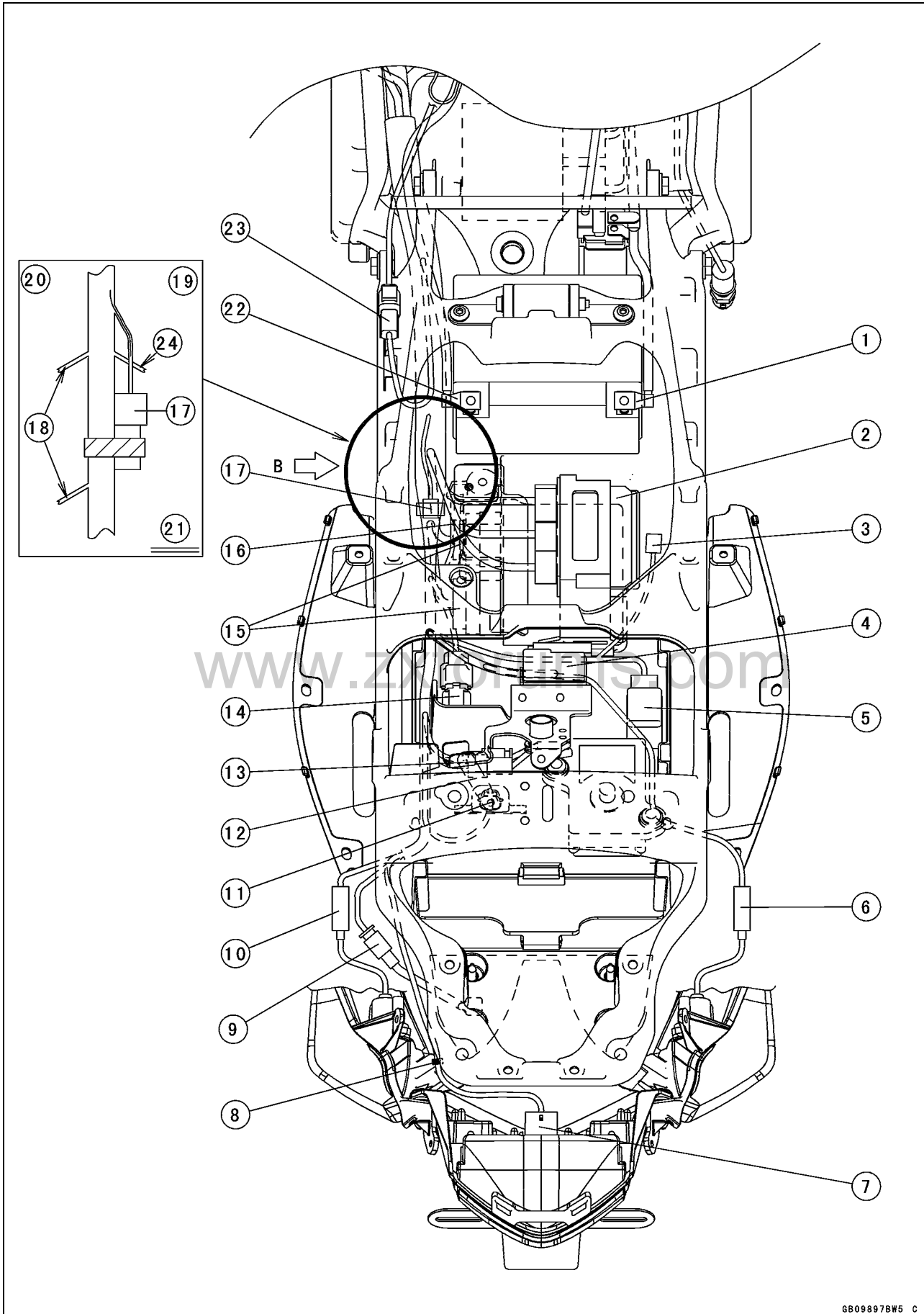

6B09897BW5 C

Cable, Wire, and Hose Routing

1. Battery Positive (+) Terminal
2. Relay Box
3. Immobilizer/Kawasaki Diagnostic System Connector
4. Fuse Box
5. Turn Signal Relay
6. Right Turn Signal Light Connector
7. Tail/Brake Light Connector
8. Clamp (The clamp attached on the main harness.)
9. License Plate Light Connector
10. Left Turn Signal Light Connector
11. Vehicle-down Sensor
12. Clamp the exhaust butterfly valve actuator connector, and push it between the left side of rear fender and the vehicle-down sensor.
13. Exhaust Butterfly Valve Actuator Connector
14. Atmospheric Pressure Sensor
15. ECU Connectors
16. Trim
17. Unused
18. ECU Leads
19. Upper
20. Under
21. Viewed B
22. Battery Negative (-) Terminal
23. Clamp the fuel pump lead connector to the bracket.
24. Relay Box Lead

www.zxforums.com

Cable, Wire, and Hose Routing

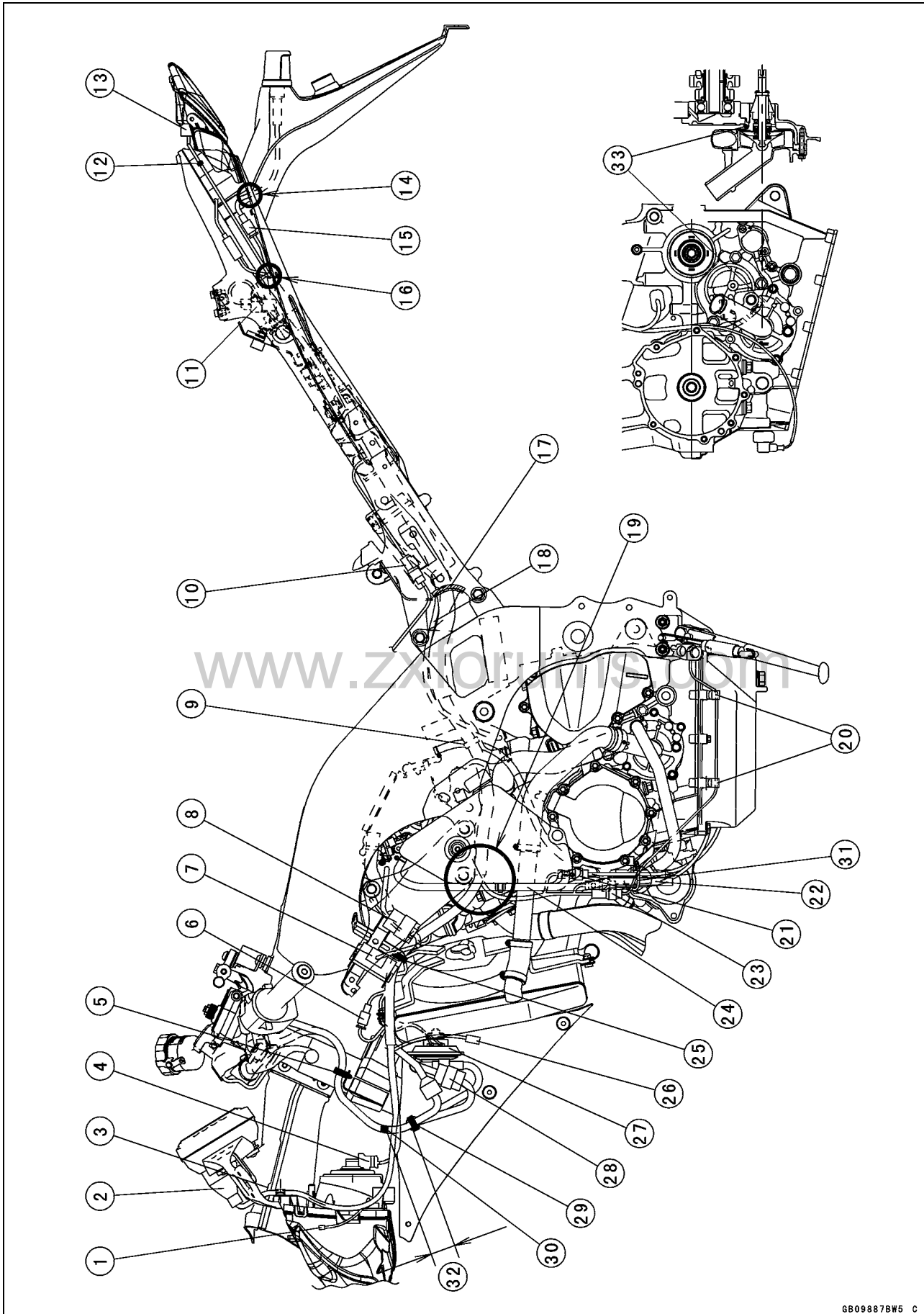

Cable, Wire, and Hose Routing

1. Left City Light Connector
2. Meter Connector
3. Clamp
4. Headlight Connector
5. Clamp
6. Run the fan motor lead connector above the main harness.
7. Immobilizer Amplifier
8. Joint Connector for the stick coil and air switching valve leads (Install it into the bracket).
9. Clamp (The clamp attached on the main harness.)
10. Fuel Pump Connector
11. Vehicle-down Sensor
12. Clamp (The clamp attached on the main harness.)
13. Tail/Brake Light Connector
14. Through the license plate light lead into the rear fender hole.
15. License Plate Light Connector
16. Run the leads to the cutted space of the rear fender rear (Left and Right).
17. Trim
18. Run the battery negative (-) cable above the main harness.
19. Do not pinch the reserve tank.
20. Clamps
21. Clamp the oxygen sensor #1 connector.
22. Clamp the oxygen sensor #2 connector.
23. Sidestand Switch Connector
24. Reserve Tank Overflow Hose
25. Install the clamp into the bracket from inside (The clamp attached on the main harness.).
26. Left Turn Signal Light Connector
27. Horn
28. Joint Connector (Ignition Switch Lead and Left Switch Housing Lead)
29. Clamp the ignition switch lead and left switch housing lead.
30. Tape (Gray)
31. Clamp
32. Within 30 mm (1.2 in.)
33. Run the gear position switch harness as shown before installing the water pump cover.

Cable, Wire, and Hose Routing

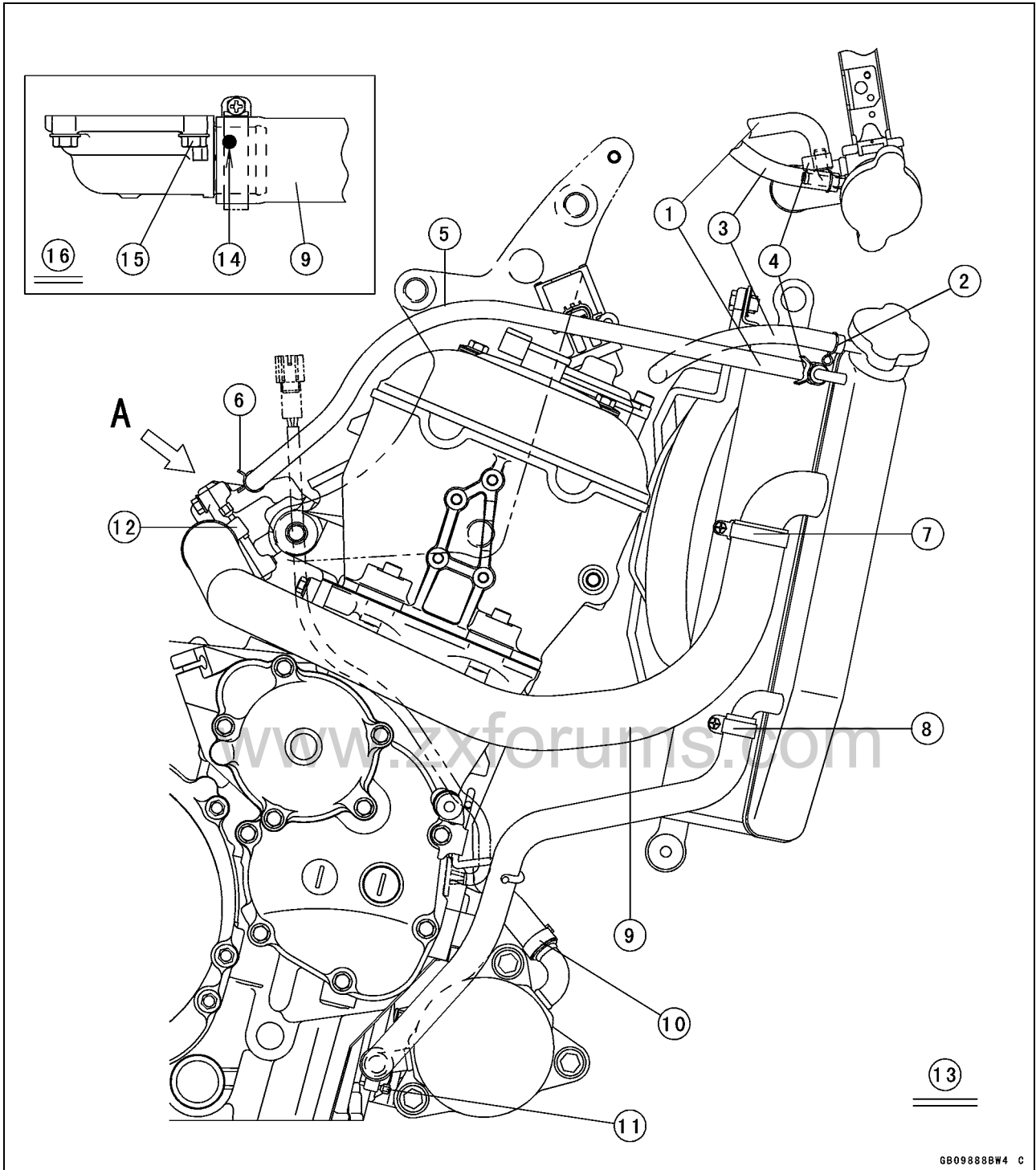

Cable, Wire, and Hose Routing

1. Insert the radiator coolant return hose to the corner portion of the radiator pipe.
2. Clamp
3. Radiator Overflow Hose
4. Clamp
5. Run the radiator coolant return hose inside the engine mount.
6. Clamp
7. Clamp
8. Clamp
9. Radiator Hose
10. Clamp
11. Install the clamp so that the clamp and the crankcase mating surface align parallel.
12. Clamp
13. Install the clamps as shown illustration noting to the direction of clip.
14. Align the paint mark (white) with the thermostat housing bolt.
15. Thermostat Housing Bolt
16. Viewed A

www.zxforums.com

Cable, Wire, and Hose Routing

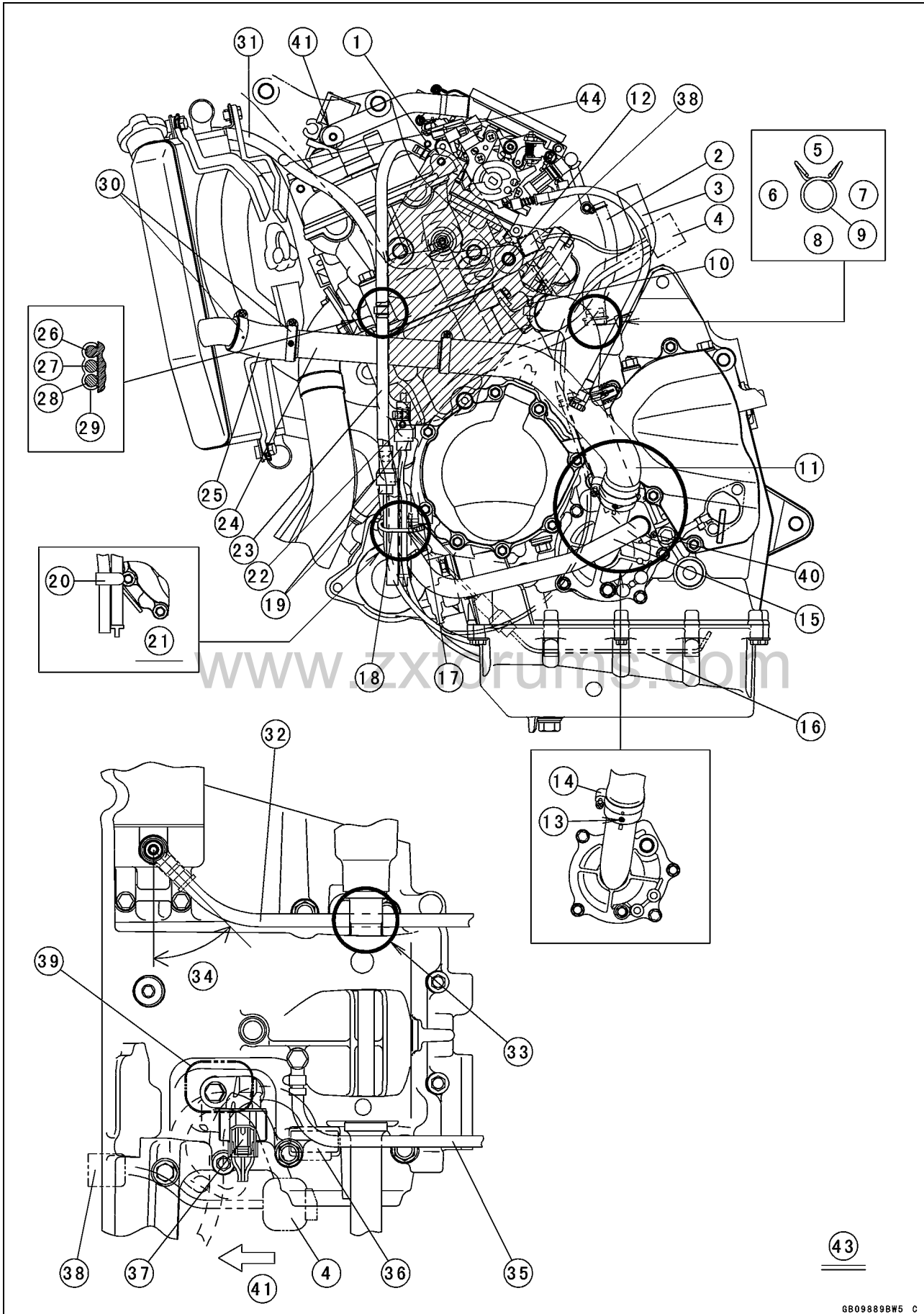

Cable, Wire, and Hose Routing

1. Clamp
2. Air Cleaner Drain Hose
3. Breather Hose
4. Joint Connector (Water Temperature Sensor Lead, Gear Position Sensor Lead, Speed Sensor Lead, and Oil Pressure Switch Lead)
5. Right Side
6. Front
7. Rear
8. Left Side
9. Clamp
10. Clamp
11. Radiator Hose
12. Clamp
13. Face the paint mark to the front.
14. Clamp
15. Water Hose (To the Oil Cooler)
16. Sidestand Switch Lead
17. Bracket
18. Clamp for the reserve tank overflow hose, oxygen sensor leads, air cleaner drain hose, and sidestand switch lead (Other than US, CA, CAL, AU, and MY Model only)
19. Oxygen Sensor Connectors (Connect to the main harness after through the sensor leads under the bracket.)
20. Clamp the sidestand switch lead and tubes.
21. US, CA, CAL, AU, and MY Model only
22. Clamp
23. Reserve Tank Overflow Hose
24. Water Pipe
25. Radiator Hose (Face the white mark outside.)
26. Reserve Tank Overflow Hose
27. Radiator Return Hose
28. Radiator Overflow Hose
29. Clamp
30. Clamps
31. Radiator Coolant Return Hose
32. Starter Motor Cable
33. Run the starter motor cable under the adjusting collar.
34. Approx. 45°
35. Engine Ground Cable
36. Alternator Lead Connector
37. Speed Sensor Connector
38. Water Temperature Sensor Connector
39. Through the alternator harness and gear position sensor harness into the heat cover hole.
40. Clamp
41. Front
42. Paint Mark (White)
43. Install the clamps as shown illustration noting to the direction of clip.
44. Through the radiator coolant return hose inside the ignition coil connector, upside of the main harness, and under the upper inner fairing bracket.

Cable, Wire, and Hose Routing

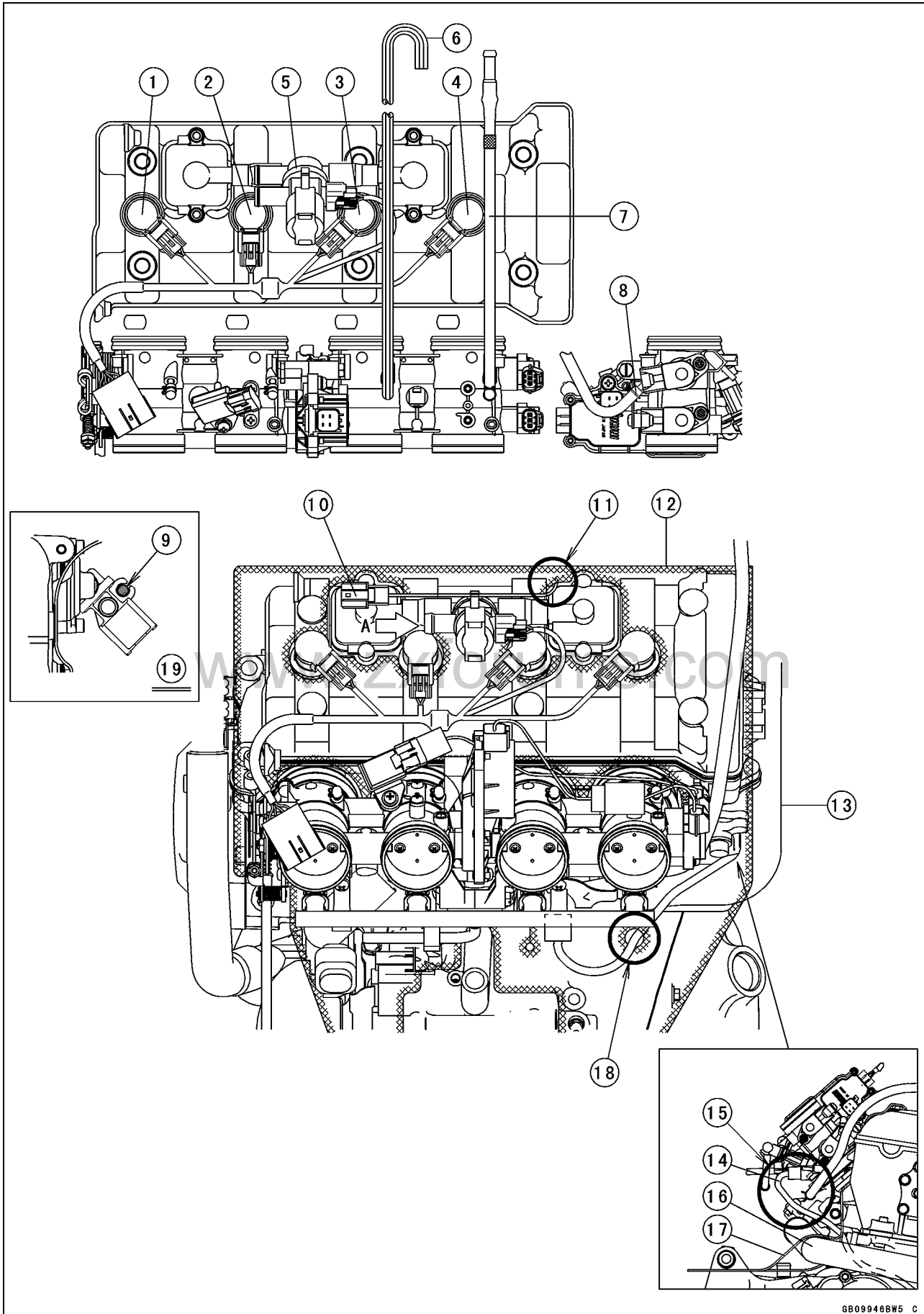

6B09946BW5 C

Cable, Wire, and Hose Routing

1. Stick Coil #1
2. Stick Coil #2
3. Stick Coil #3
4. Stick Coil #4
5. Air Switching Valve
6. Evaporative Hose (White)
7. Evaporative Hose (Green)
8. Clamp
9. Through the crankshaft sensor lead into the clamp (attached on the air switching valve).
10. Crankshaft Sensor Lead Connector
11. Through the crankshaft sensor lead into the hole of the heat insulation rubber plate.
12. Heat Insulation Rubber Plate
13. Radiator Hose
14. Crankshaft Sensor Lead
15. Through the crankshaft sensor lead inside the radiator hose.
16. Radiator Hose
17. Heat Insulation Rubber Plate
18. Through the crankshaft sensor lead into the hole of the heat insulation rubber plate.
19. Viewed A

www.zxforums.com

Cable, Wire, and Hose Routing

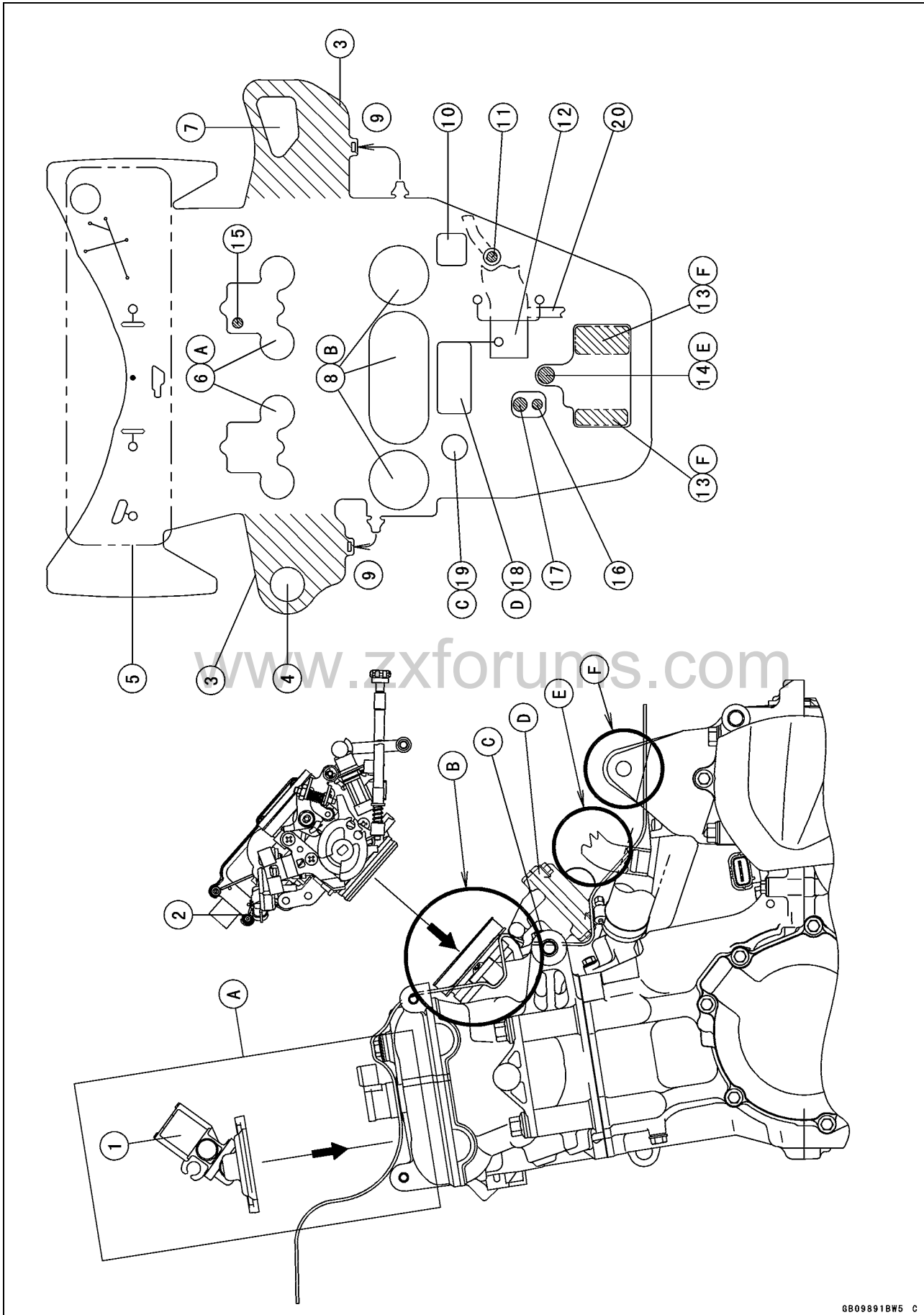

GB09891BW5 C

Cable, Wire, and Hose Routing

1. Install the air switching valve after installing the heat insulation rubber plate.
2. Throttle Body Assy
3. Hang down the shaded portions of the heat insultaion rubber plate.
4. For Left Engine Bracket Bolt
5. For Radiator
6. For Air Suction Valve Covers and Stick Coils
7. For Right Engine Bracket (Cylinder Head Side)
8. For Throttle Body Holders
9. Set the projection into the hole.
10. For Right Front Engine Mount
11. Crankshaft Sensor Lead
12. Through the water hose under the heat insulation rubber plate.
13. For Middle Engine Mount
14. For Breather Tube
15. For Camshaft Sensor Lead
16. Alternator Lead
17. Gear Position Switch Lead
18. For Thermostat Case
19. For Water Temperature Sensor
20. Through the starter motor cable under the water hose.

www.zxforums.com

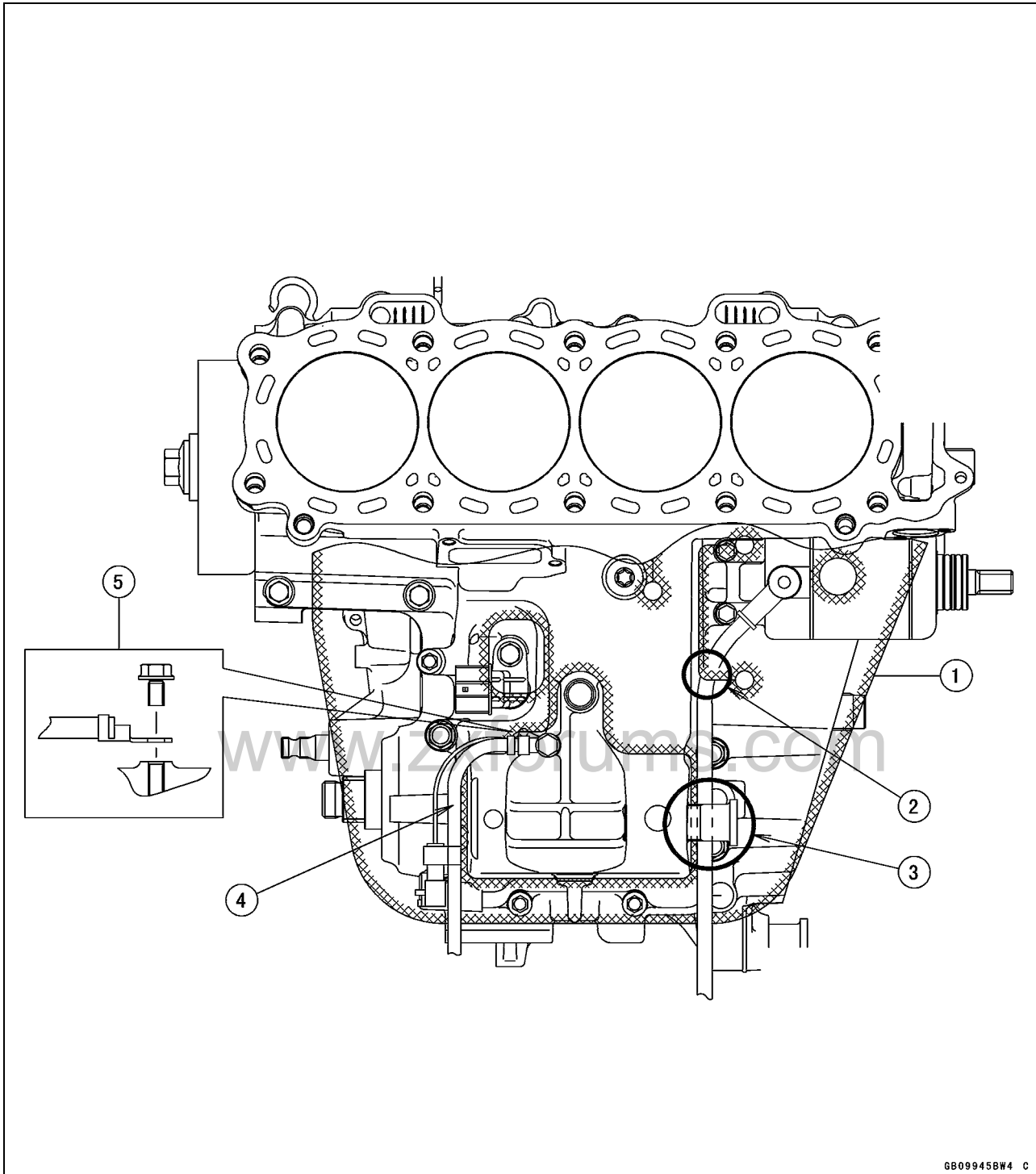
Cable, Wire, and Hose Routing

1. Heat Insulation Rubber Plate
2. Run the starter motor cable into the hole of the heat insulation rubber plate.
3. Run the starter motor cable under the adjusting collar.
4. Engine Ground Cable
5. Install the engine ground cable as shown.

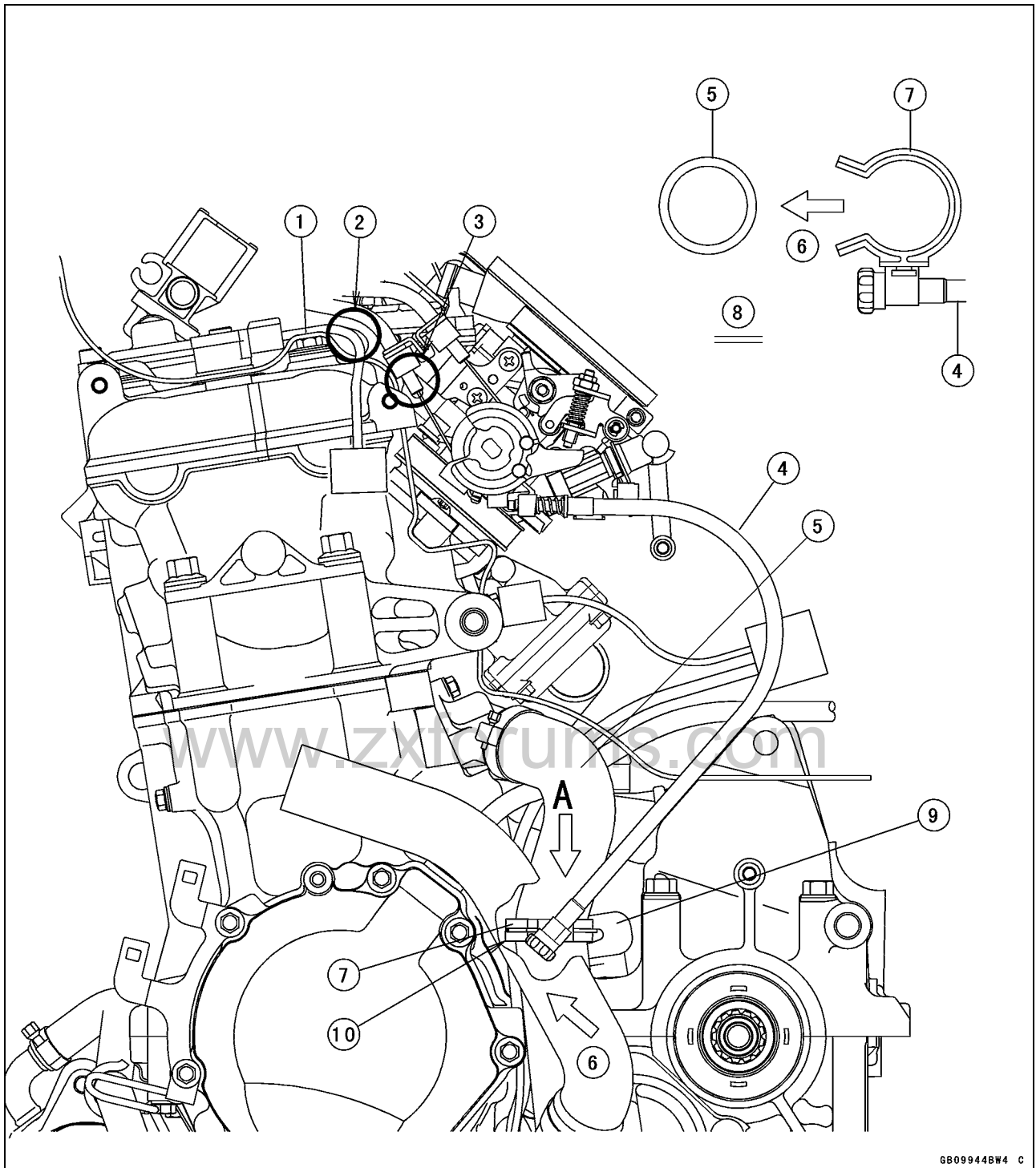
Cable, Wire, and Hose Routing

1. Ignition Coil Lead
2. Run the ignition coil lead.
3. Do not pinch the ignition coil lead.
4. Idle Adjusting Cable
5. Radiator Hose
6. Install the idle adjuster screw direction as shown.
7. Clamp
8. Viewed A
9. Speed Sensor
10. Align the clamp with the speed sensor.

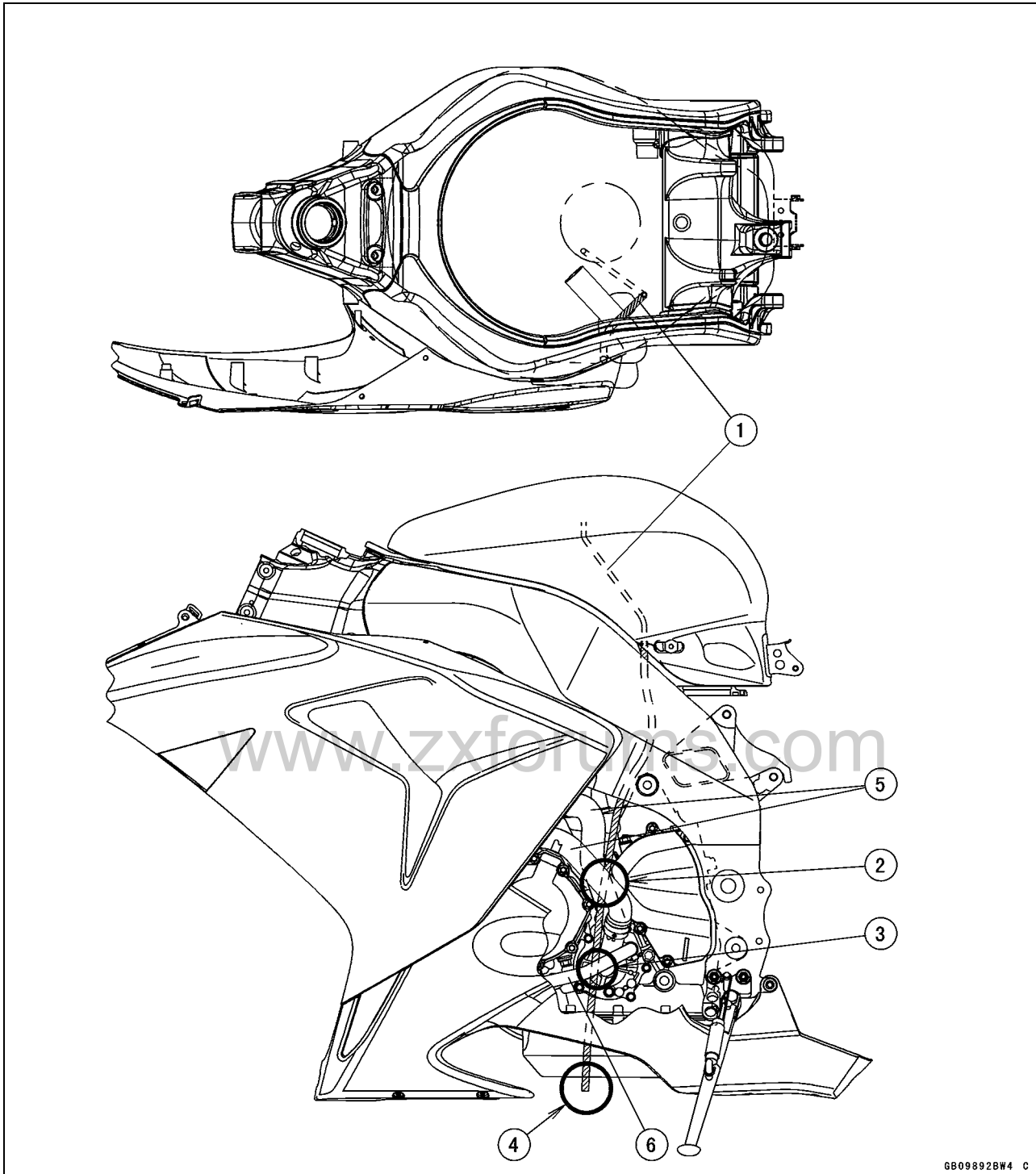
Cable, Wire, and Hose Routing

1. Fuel Tank Drain Hose
2. Run the drain hose inside the radiator hose.
3. Run the drain hose inside the water hose.
4. Put the hose through the cut hole of the under fairing.
5. Radiator Hoses
6. Water Hose

Cable, Wire, and Hose Routing

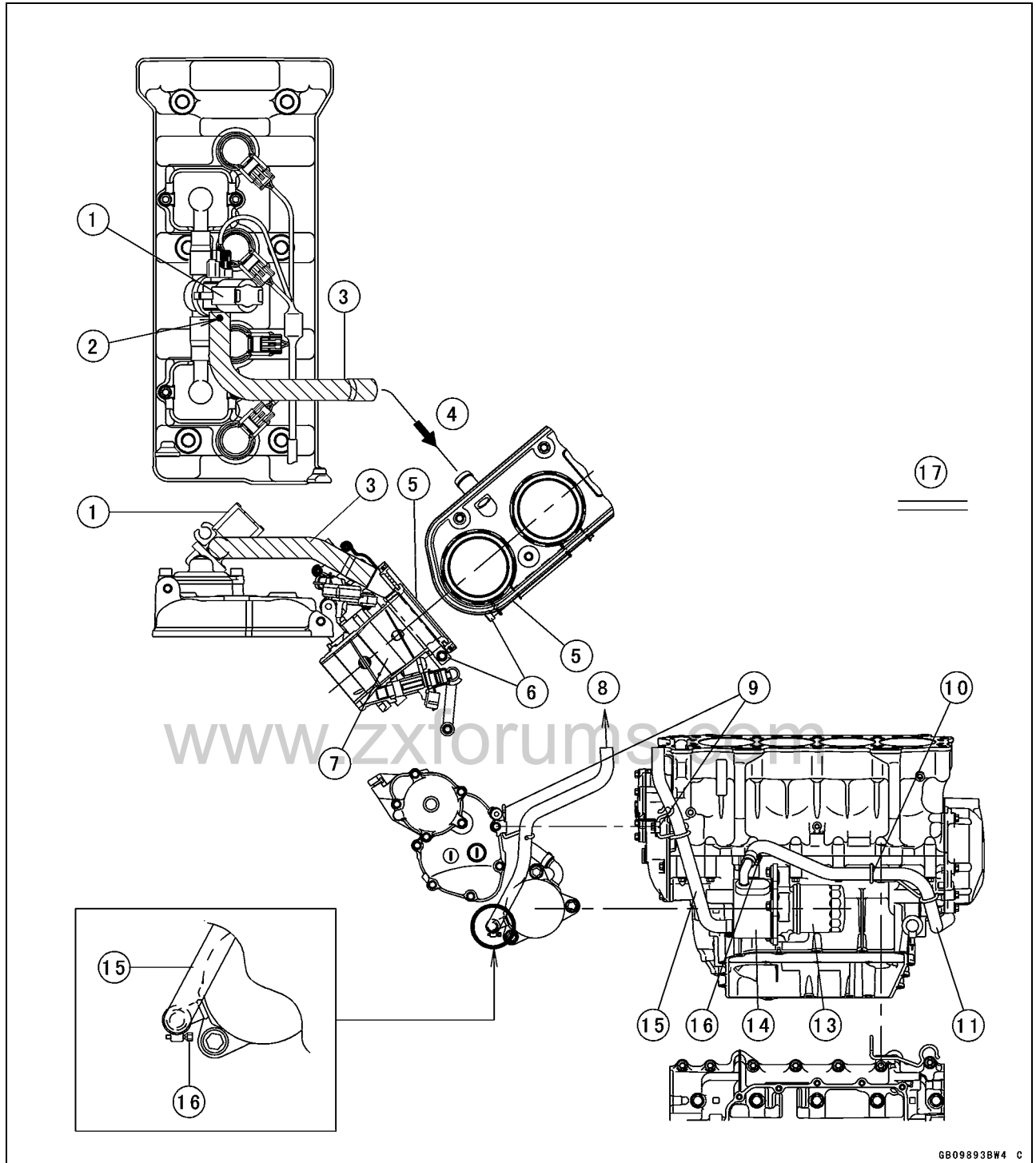

- | | |
|--|--|
| <ul style="list-style-type: none"> 1. Air Switching Valve 2. Face the paint mark upward. 3. Air Switching Valve Hose 4. To the fitting of the holder assy. 5. Holder Assy 6. Clamp 7. Throttle Body Assy 8. To the Radiator 9. Install the starter cover bolt with the clamp. | <ul style="list-style-type: none"> 10. Run the water hose through the clamp. 11. Water Hose 12. Install the upper crankcase bolt with the clamp. 13. Oil Filter 14. Oil Cooler 15. Water Hose 16. Clamps 17. Install the clamps as shown illustration noting to the direction of clip. |
|--|--|

Cable, Wire, and Hose Routing

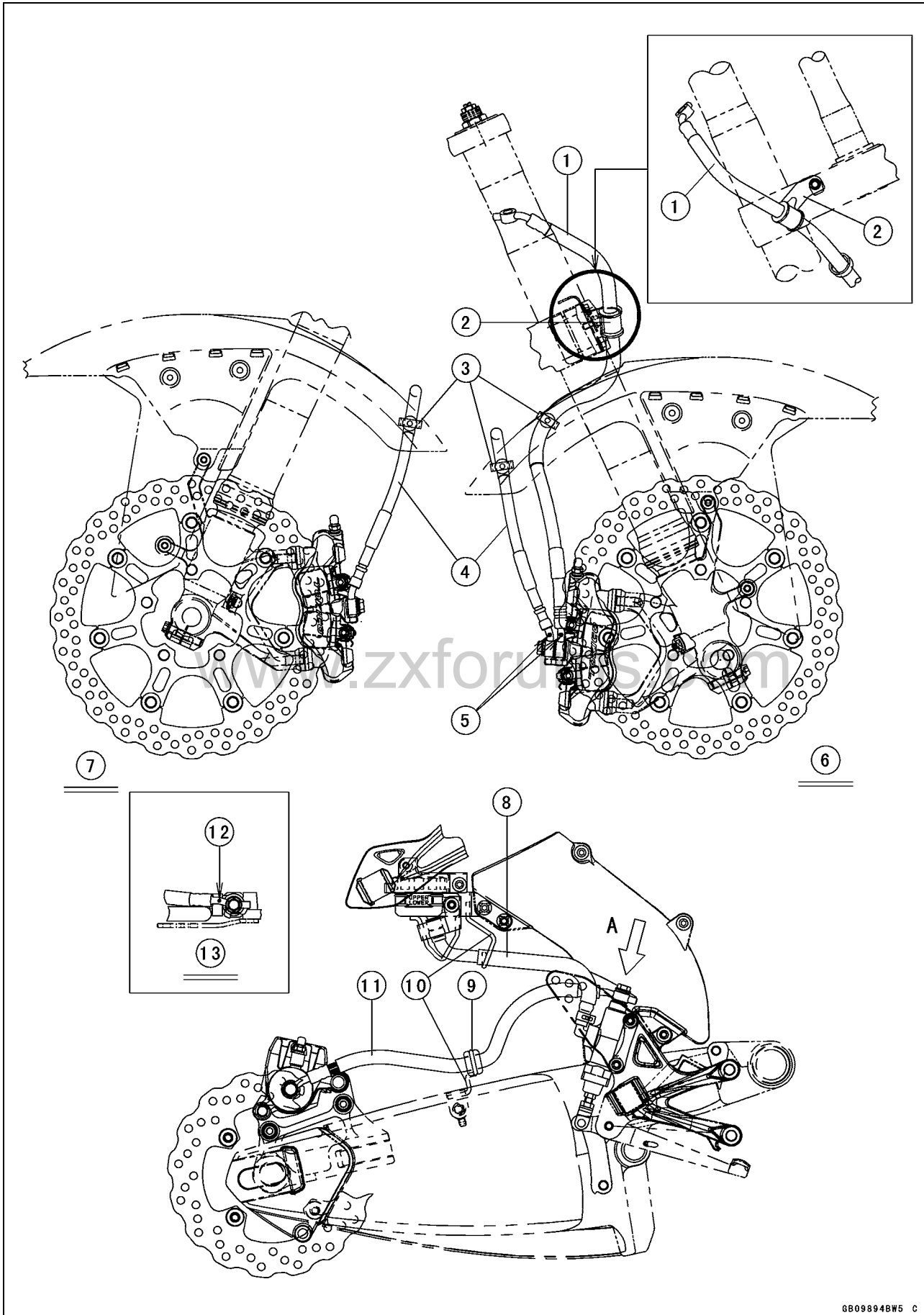

Cable, Wire, and Hose Routing

1. Brake Hose
2. Clamp
3. Clamps
4. Brake Hoses
5. Face the paint mark outside.
6. Viewed Right Side
7. Viewed Left Side
8. Brake Hose
9. Rubber Dumper
10. Clamps
11. Brake Hose
12. Face the paint mark outside.
13. Viewed A

www.zxforums.com

Cable, Wire, and Hose Routing

California Model

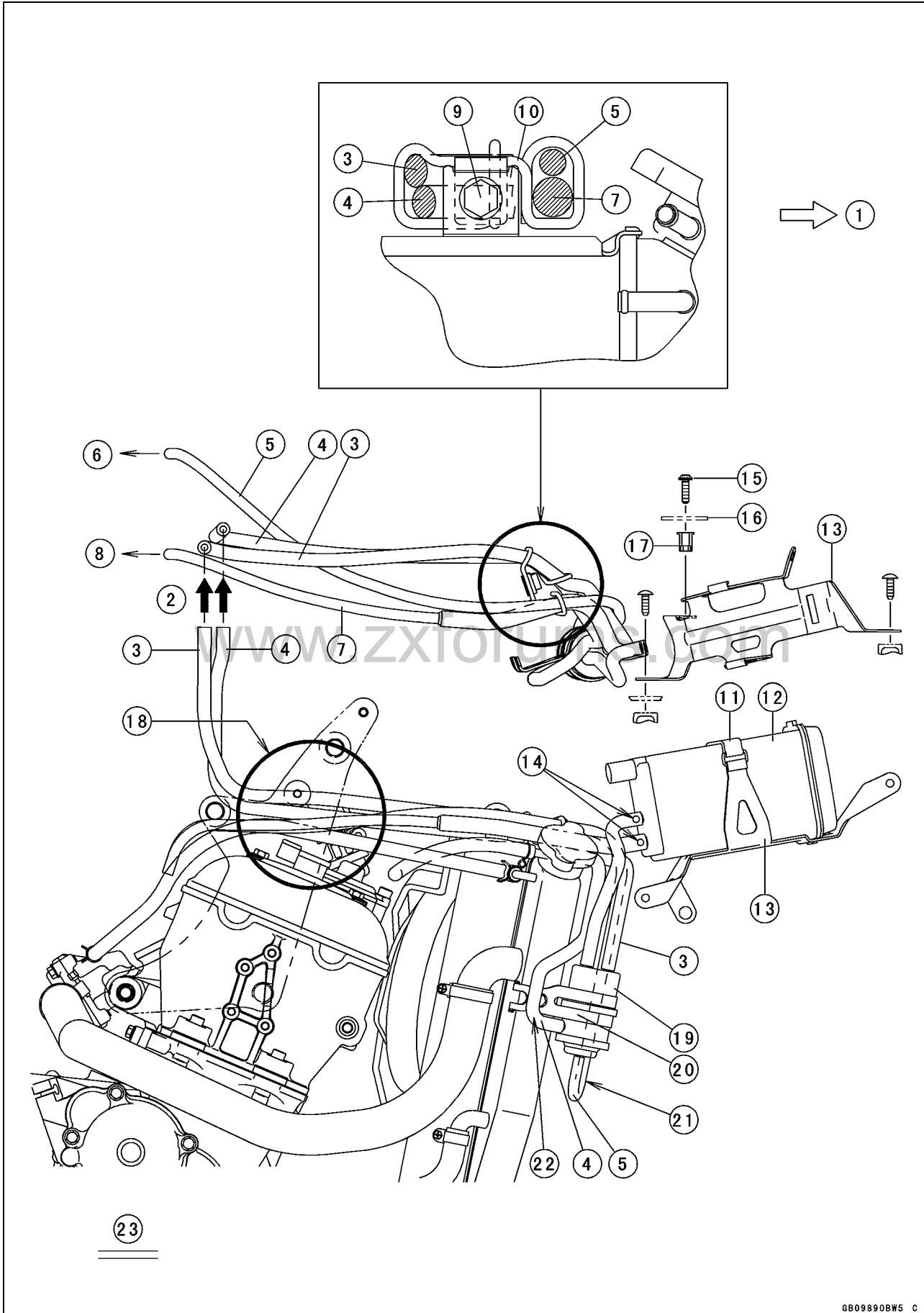

Cable, Wire, and Hose Routing

1. Front
2. To the Fuel Tank
3. Hose (Blue)
4. Hose (Red)
5. Hose (White)
6. To the fitting of the Throttle Body #3 (Run the hose over the subthrottle valve actuator connector.)
7. Hose (Green)
8. To the fitting of the Throttle Body #4 (Run the hose under the harness.)
9. Bolt
10. Clamp
11. Band
12. Canister
13. Bracket
14. Face the point mark (white) to the right.
15. Bolt
16. Right Inner Fairing
17. Nut
18. Run the hoses inside the engine bracket.
19. Separator
20. Bracket
21. Run the white hose to the forward.
22. Run the red hose to the rearward.
23. Install the clamps as shown illustration noting to the direction of clip.

www.zxforums.com

Cable, Wire, and Hose Routing

California Model

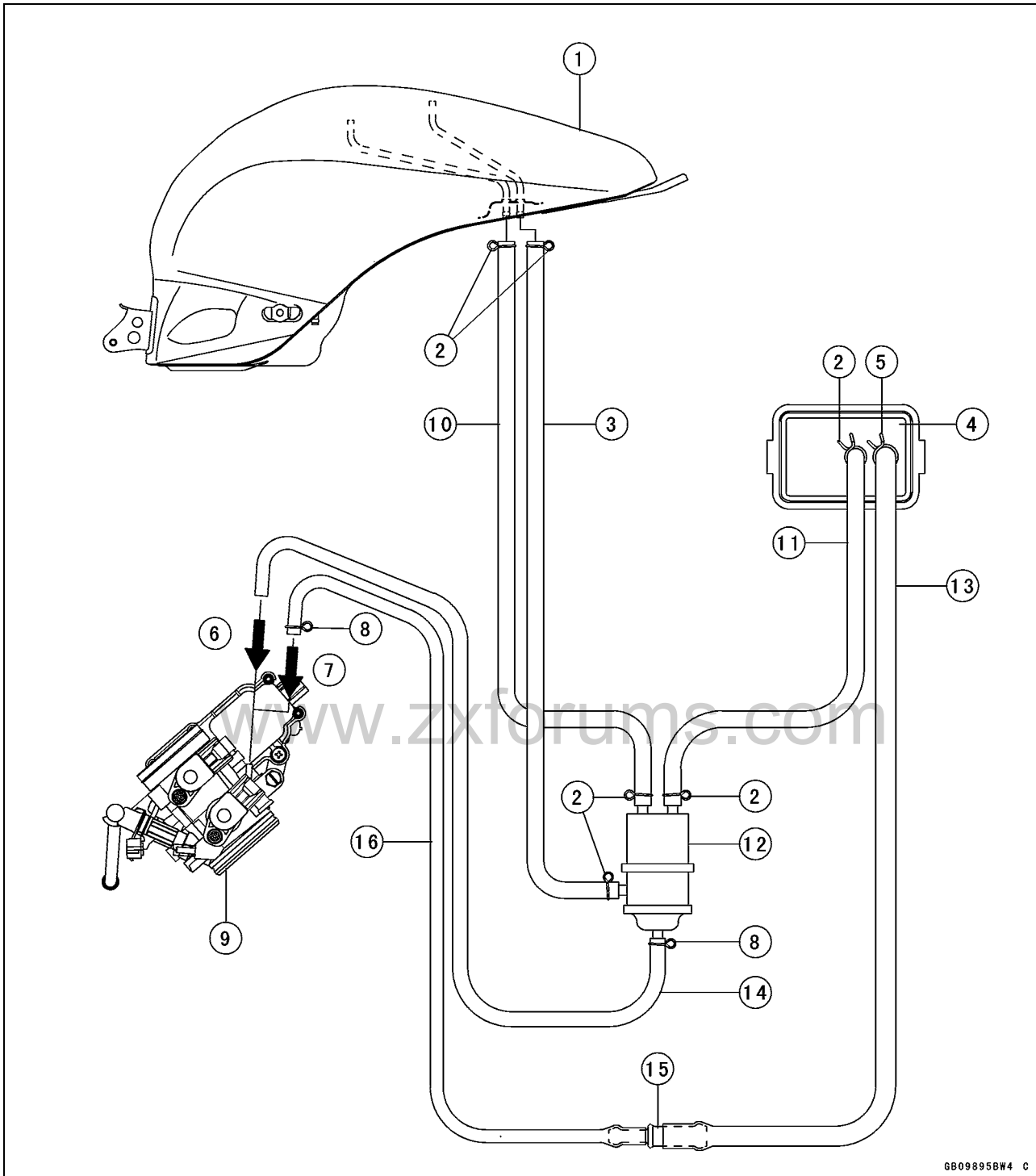

GB09895BW4 C

- | | |
|---|--------------------|
| 1. Fuel Tank | 9. Throttle Bodies |
| 2. Clamps | 10. Hose (Blue) |
| 3. Hose (Red) | 11. Hose (Blue) |
| 4. Canister | 12. Separator |
| 5. Clamp | 13. Hose (Green) |
| 6. To the Fitting of the Throttle Body #3 | 14. Hose (White) |
| 7. To the Fitting of the Throttle Body #4 | 15. Fitting |
| 8. Clamps | 16. Hose (Green) |

Cable, Wire, and Hose Routing

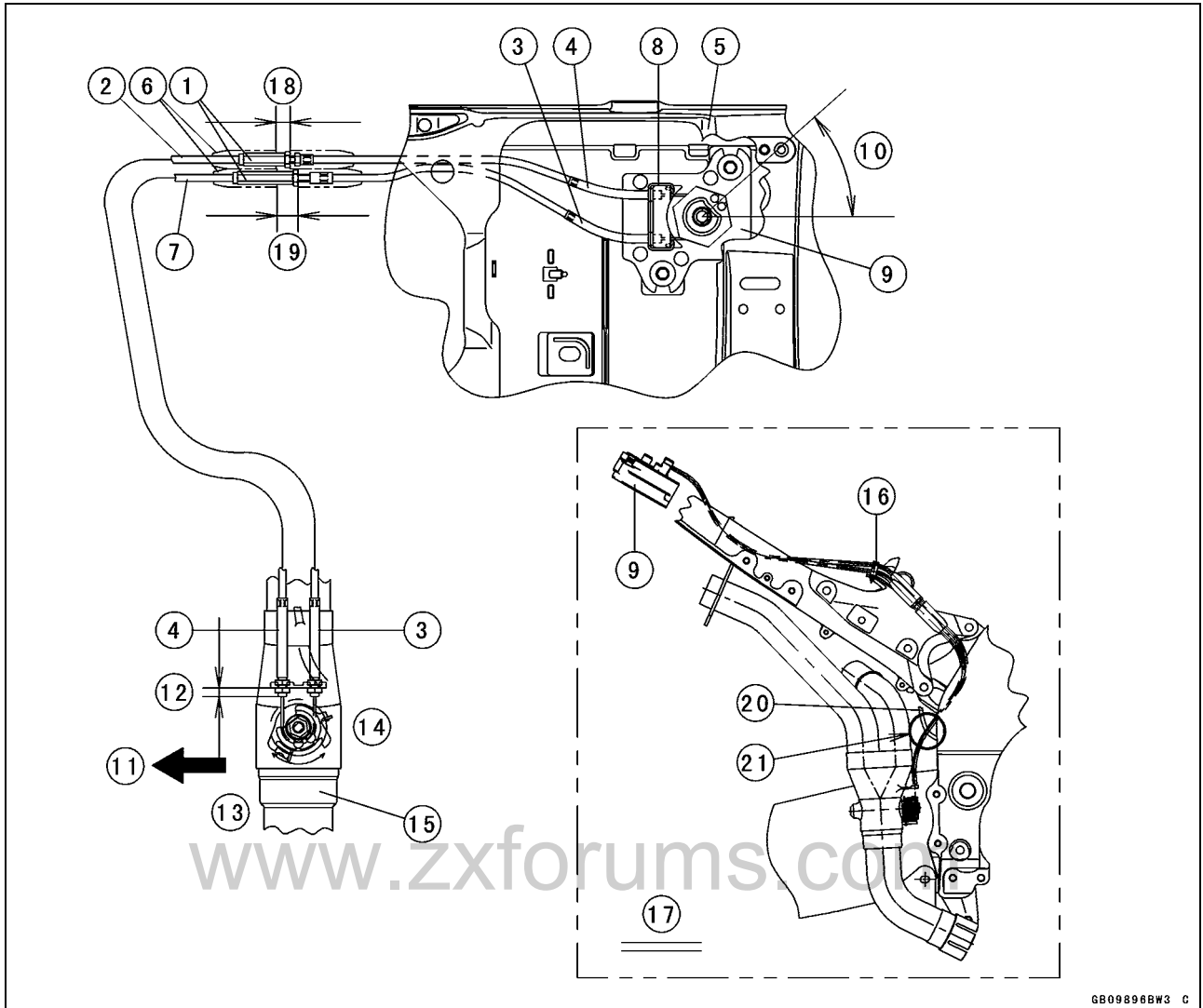

6B09896BW3 C

1. Adjusters
2. Closing Cable
3. Yellow
4. Dark Green
5. Rear Frame
6. Dust Covers
7. Opening Cable
8. Clamp
9. Exhaust Butterfly Valve Actuator
10. $41.7^\circ \pm 7^\circ$ (Original Position of Pulley)
11. Right Side
12. 6 mm (0.24 in.)
13. Close
14. Open
15. Exhaust Manifold
16. Clamp
17. Viewed Right Side
18. 10 mm (0.40 in.) or less
19. 15 mm (0.60 in.) or less
20. Starter Motor Cable
21. Through the exhaust butterfly valve cables inside of the starter motor cables.

Troubleshooting Guide

NOTE

- Refer to the *Fuel System* chapter for most of DFI trouble shooting guide.
- This is not an exhaustive list, giving every possible cause for each problem listed. It is meant simply as a rough guide to assist the troubleshooting for some of the more common difficulties.

Engine Doesn't Start, Starting Difficulty:

Starter motor not rotating:

- Starter lockout switch or neutral switch trouble
- Starter motor trouble
- Battery voltage low
- Starter relay not contacting or operating
- Starter button not contacting
- Wiring open or shorted
- Ignition switch trouble
- Engine stop switch trouble
- Fuse blown

Starter motor rotating but engine doesn't turn over:

- Immobilizer system trouble
- Starter clutch trouble
- Vehicle-down sensor (DFI) coming off

Engine won't turn over:

- Valve seizure
- Valve lifter seizure
- Cylinder, piston seizure
- Crankshaft seizure
- Connecting rod small end seizure
- Connecting rod big end seizure
- Transmission gear or bearing seizure
- Camshaft seizure
- Starter idle gear seizure

No fuel flow:

- No fuel in tank
- Fuel pump trouble
- Fuel tank air vent obstructed
- Fuel filter clogged
- Fuel line clogged

No spark; spark weak:

- Vehicle-down sensor (DFI) coming off
- Ignition switch not ON
- Engine stop switch turned OFF
- Clutch lever not pulled in or gear not in neutral
- Battery voltage low
- Immobilizer system trouble
- Spark plug dirty, broken, or gap maladjusted
- Stick coil shorted or not in good contact
- Stick coil trouble
- Spark plug incorrect
- IC igniter in ECU trouble

- Camshaft position sensor trouble
- Neutral, starter lockout, or sidestand switch trouble
- Crankshaft sensor trouble
- Ignition switch or engine stop switch shorted
- Wiring shorted or open
- Fuse blown

Fuel/air mixture incorrect:

- Bypass screw and/or idle adjusting screw maladjusted
- Air passage clogged
- Air cleaner clogged, poorly sealed, or missing

Compression Low:

- Spark plug loose
- Cylinder head not sufficiently tightened down
- No valve clearance
- Cylinder, piston worn
- Piston ring bad (worn, weak, broken, or sticking)
- Piston ring/groove clearance excessive
- Cylinder head gasket damaged
- Cylinder head warped
- Valve spring broken or weak
- Valve not seating properly (valve bent, worn, or carbon accumulation on the seating surface)

Poor Running at Low Speed:

Spark weak:

- Battery voltage low
- Spark plug dirty, broken, or maladjusted
- Stick coil wiring trouble
- Stick coil not in good contact
- Spark plug incorrect
- IC igniter in ECU trouble
- Camshaft position sensor trouble
- Crankshaft sensor trouble
- Stick coil trouble
- Immobilizer system trouble

Fuel/air mixture incorrect:

- Bypass screw maladjusted
- Air passage clogged
- Air bleed pipe bleed holes clogged
- Pilot passage clogged
- Air cleaner clogged, poorly sealed, or missing
- Fuel tank air vent obstructed
- Fuel pump trouble
- Throttle body assy holder loose
- Air cleaner duct loose

Compression low:

- Spark plug loose
- Cylinder head not sufficiently tightened down

Troubleshooting Guide

No valve clearance
Cylinder, piston worn
Piston ring bad (worn, weak, broken, or sticking)
Piston ring/groove clearance excessive
Cylinder head warped
Cylinder head gasket damaged
Valve spring broken or weak
Valve not seating properly (valve bent, worn, or carbon accumulation on the seating surface)

Other:

IC igniter in ECU trouble
Throttle body assy not synchronizing
Engine oil viscosity too high
Drive train trouble
Brake dragging
Air suction valve trouble
Air switching valve trouble
Engine overheating
Clutch slipping

Poor Running or No Power at High Speed:

Firing incorrect:

Spark plug dirty, broken, or maladjusted
Stick coil wiring trouble
Stick coil not in good contact
Spark plug incorrect
Camshaft position sensor trouble
IC igniter in ECU trouble
Crankshaft sensor trouble
Stick coil trouble

Fuel/air mixture incorrect:

Air cleaner clogged, poorly sealed, or missing
Air cleaner O-ring damaged
Air cleaner duct loose
Water or foreign matter in fuel
Throttle body assy holder loose
Fuel to injector insufficient (DFI)
Fuel tank air vent obstructed
Fuel line clogged
Fuel pump trouble (DFI)

Compression low:

Spark plug loose
Cylinder head not sufficiently tightened down
No valve clearance
Cylinder, piston worn
Piston ring bad (worn, weak, broken, or sticking)
Piston ring/groove clearance excessive
Cylinder head gasket damaged
Cylinder head warped
Valve spring broken or weak

Valve not seating properly (valve bent, worn, or carbon accumulation on the seating surface.)

Knocking:

Carbon built up in combustion chamber
Fuel poor quality or incorrect
Spark plug incorrect
IC igniter in ECU trouble
Camshaft position sensor trouble
Crankshaft sensor trouble

Miscellaneous:

Throttle valve won't fully open
Brake dragging
Clutch slipping
Engine overheating
Engine oil level too high
Engine oil viscosity too high
Drive train trouble
Air suction valve trouble
Air switching valve trouble
Catalytic converter melt down due to muffler overheating (KLEEN)

Overheating:

Firing incorrect:

Spark plug dirty, broken, or maladjusted
Spark plug incorrect
IC igniter in ECU trouble

Muffler overheating:

For KLEEN, do not run the engine even if with only one cylinder misfiring or poor running (Request the nearest service facility to correct it)
For KLEEN, do not push-start with a dead battery (Connect another full-charged battery with jumper cables, and start the engine using the electric starter)
For KLEEN, do not start the engine under misfire due to spark plug fouling or poor connection of the stick coil
For KLEEN, do not coast the motorcycle with the ignition switch off (Turn the ignition switch ON and run the engine)
IC igniter in ECU trouble

Fuel/air mixture incorrect:

Throttle body assy holder loose
Air cleaner duct loose
Air cleaner poorly sealed, or missing
Air cleaner O-ring damaged
Air cleaner clogged

Compression high:

Carbon built up in combustion chamber

Engine load faulty:

Clutch slipping
Engine oil level too high
Engine oil viscosity too high
Drive train trouble

Troubleshooting Guide

Brake dragging

Lubrication inadequate:

Engine oil level too low

Engine oil poor quality or incorrect

Oil cooler incorrect:

Oil cooler clogged

Gauge incorrect:

Water temperature gauge broken

Water temperature sensor broken

Coolant incorrect:

Coolant level too low

Coolant deteriorated

Wrong coolant mixed ratio

Cooling system component incorrect:

Radiator fin damaged

Radiator clogged

Thermostat trouble

Radiator cap trouble

Radiator fan relay trouble

Fan motor broken

Fan blade damaged

Water pump not turning

Water pump impeller damaged

Over Cooling:

Gauge incorrect:

Water temperature gauge broken

Water temperature sensor broken

Cooling system component incorrect:

Thermostat trouble

Clutch Operation Faulty:

Clutch slipping:

Friction plate worn or warped

Steel plate worn or warped

Clutch spring broken or weak

Clutch hub or housing unevenly worn

No clutch lever play

Clutch inner cable trouble

Clutch release mechanism trouble

Clutch not disengaging properly:

Clutch plate warped or too rough

Clutch spring compression uneven

Engine oil deteriorated

Engine oil viscosity too high

Engine oil level too high

Clutch housing frozen on drive shaft

Clutch hub nut loose

Clutch hub spline damaged

Clutch friction plate installed wrong

Clutch lever play excessive

Clutch release mechanism trouble

Gear Shifting Faulty:

Doesn't go into gear; shift pedal doesn't return:

Clutch not disengaging

Shift fork bent or seized

Gear stuck on the shaft

Gear positioning lever binding

Shift return spring weak or broken

Shift return spring pin loose

Shift mechanism arm spring broken

Shift mechanism arm broken

Shift pawl broken

Jumps out of gear:

Shift fork ear worn, bent

Gear groove worn

Gear dogs and/or dog holes worn

Shift drum groove worn

Gear positioning lever spring weak or broken

Shift fork guide pin worn

Drive shaft, output shaft, and/or gear splines worn

Overshifts:

Gear positioning lever spring weak or broken

Shift mechanism arm spring broken

Abnormal Engine Noise:

Knocking:

IC igniter in ECU trouble

Carbon built up in combustion chamber

Fuel poor quality or incorrect

Spark plug incorrect

Overheating

Piston slap:

Cylinder/piston clearance excessive

Cylinder, piston worn

Connecting rod bent

Piston pin, piston pin hole worn

Valve noise:

Valve clearance incorrect

Valve spring broken or weak

Camshaft bearing worn

Valve lifter worn

Other noise:

Connecting rod small end clearance excessive

Connecting rod big end clearance excessive

Piston ring/groove clearance excessive

Piston ring worn, broken, or stuck

Piston ring groove worn

Piston seizure, damage

Cylinder head gasket leaking

Exhaust pipe leaking at cylinder head con-

nection
Crankshaft runout excessive

Troubleshooting Guide

Engine mount loose
Crankshaft bearing worn
Primary gear worn or chipped
Camshaft chain tensioner trouble
Camshaft chain, sprocket, guide worn
Air suction valve damaged
Air switching valve damaged
Alternator rotor loose
Catalytic converter melt down due to muffler overheating (KLEEN)

Abnormal Drive Train Noise:

Clutch noise:

Clutch housing/friction plate clearance excessive
Clutch housing gear worn
Wrong installation of outside friction plate

Transmission noise:

Bearings worn
Transmission gear worn or chipped
Metal chips jammed in gear teeth
Engine oil insufficient

Drive line noise:

Drive chain adjusted improperly
Drive chain worn
Rear and/or engine sprocket worn
Chain lubrication insufficient
Rear wheel misaligned

Abnormal Frame Noise:

Front fork noise:

Oil insufficient or too thin
Spring weak or broken

Rear shock absorber noise:

Shock absorber damaged

Disc brake noise:

Pad installed incorrectly
Pad surface glazed
Disc warped
Caliper trouble

Other noise:

Bracket, nut, bolt, etc. not properly mounted or tightened

Oil Pressure Warning Light Goes On:

Engine oil pump damaged
Engine oil screen clogged
Engine oil filter clogged
Engine oil level too low
Engine oil viscosity too low
Camshaft bearing worn
Crankshaft bearing worn
Oil pressure switch damaged
Wiring faulty
Relief valve stuck open

O-ring at the oil passage in the crankcase damaged

Exhaust Smokes Excessively:

White smoke:

Piston oil ring worn
Cylinder worn
Valve oil seal damaged
Valve guide worn
Engine oil level too high

Black smoke:

Air cleaner clogged

Brown smoke:

Air cleaner duct loose
Air cleaner O-ring damaged
Air cleaner poorly sealed or missing

Handling and/or Stability

Unsatisfactory:

Handlebar hard to turn:

Cable routing incorrect
Hose routing incorrect
Wiring routing incorrect
Steering stem nut too tight
Steering stem bearing damaged
Steering stem bearing lubrication inadequate
Steering stem bent
Tire air pressure too low

Handlebar shakes or excessively vibrates:

Tire worn
Swingarm pivot bearing worn
Rim warped, or not balanced
Wheel bearing worn
Handlebar bolt loose
Steering stem nut loose
Front, rear axle runout excessive
Engine mounting nut loose

Handlebar pulls to one side:

Frame bent
Wheel misalignment
Swingarm bent or twisted
Swingarm pivot shaft runout excessive
Steering maladjusted
Front fork bent
Right and left front fork oil level uneven

Shock absorption unsatisfactory:

(Too hard)
Front fork oil excessive
Front fork oil viscosity too high
Rear shock absorber adjustment too hard
Tire air pressure too high
Front fork bent
(Too soft)
Tire air pressure too low
Front fork oil insufficient and/or leaking
Front fork oil viscosity too low

Troubleshooting Guide

- Rear shock adjustment too soft
- Front fork, rear shock absorber spring weak
- Rear shock absorber oil leaking

Brake Doesn't Hold:

- Air in the brake line
- Pad or disc worn
- Brake fluid leakage
- Disc warped
- Contaminated pad
- Brake fluid deteriorated
- Primary or secondary cup damaged in master cylinder
- Master cylinder scratched inside

Battery Trouble:

Battery discharged:

- Charge insufficient
- Battery faulty (too low terminal voltage)
- Battery lead making poor contact
- Load excessive (e.g., bulb of excessive wattage)
- Ignition switch trouble
- Alternator trouble
- Wiring faulty
- Regulator/rectifier trouble

Battery overcharged:

- Alternator trouble
- Regulator/rectifier trouble
- Battery faulty

MODEL APPLICATION

Year	Model	Beginning Frame No.
2006	ZX1000D6F	JKAZXCD1□6A000001 JKAZXT00DDA000001 ZXT00D-000001

□:This digit in the frame number changes from one machine to another.

www.zxforums.com



KAWASAKI HEAVY INDUSTRIES, LTD.
Consumer Products & Machinery Company

www.zxforums.com
Part No.99924-1365-02