

# Repair Manual



**R 1100 RT**

**R 1100 RS**

**R 850/1100 GS**

**R 850/1100 R**

**BMW Motorcycle  
After Sales**

Published by: © BMW Motorcycle  
After Sales  
UX-VS-2

All rights reserved. Not to be reprinted, translated or duplicated either wholly or in part without prior written permission.  
Errors and omissions excepted; subject to technical amendment.

Produced in Germany 02/00

# Introduction

This repair manual will help you to perform all the main maintenance and repair work correctly and efficiently. It should be consulted regularly by workshop personnel as an addition to the practical and theoretical knowledge obtained in Training School courses. It is a contribution towards achieving even higher Service quality.

All information in both text and illustrations refers to motorcycles in standard condition or with genuine BMW accessories installed, and not to motorcycles which have been modified in any way to depart from the manufacturer's specification.

- The repair manual is structured in the logical sequence of the work to be performed: Removal, Disassembly, Repair, Assembly, Installation.
- The entire contents are divided into individual chapters, corresponding to the Construction Groups.

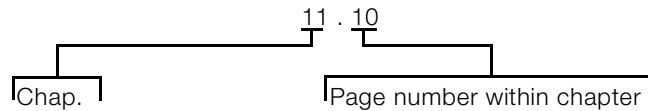

- Work to be performed during an Inspection is described in Group "00". The various inspection routines are numbered I, II, III and IV. This numbering is repeated in the work descriptions which follow, so that work can take place without interruption.
- Use of the BMW special tools needed for certain tasks is described in the work instructions.

If the need arises, repair instructions are also issued in the form of Service Information. This information is of course incorporated into the next issue of the repair manual. We also recommend you to consult the detailed illustrations on the Parts microfiches as an additional source of information.

BMW Motorcycle  
After Sales

Published by: BMW Motorrad  
Hufelandstr. 6  
D - 80937 München

All rights reserved. Not to be reprinted, translated or duplicated either wholly or in part without prior written permission.  
Errors and omissions excepted; subject to technical amendment.  
Produced in Germany

# Contents

## Group / Chapter

**00 Maintenance and general instructions**



**11 Motor**

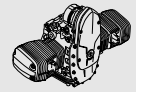

**12 Engine electrics**



**13 Fuel preparation and control**

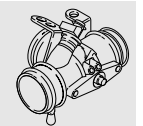

**16 Fuel tank and lines**



**18 Exhaust system**



**21 Clutch**



**23 Gearbox**



**31 Front fork**



**32 Steering**



**33 Rear wheel drive**

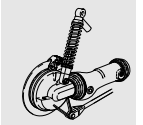

**>> Continuation**

## Group / Chapter

**34 Brakes**

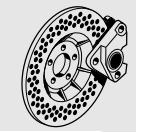

**36 Wheels and tyres**



**46 Frame**



**51 Equipment**

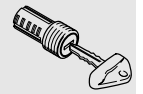

**52 Seat**



**61 General electrical equipment**



**62 Instruments**



**63 Lights**



**<< Back**

# BMW AG Motorcycle Division

## Maintenance Schedule

### R 1100 RT/R 1100 RS/R 850 GS/R 1100 GS/R 850R/R 1100 R



		BMW Inspection 1000 km/600 mls	BMW Service 10 000 km/6000 mls	BMW Inspection 20 000 km/12 000 mls	BMW Annual Service
Customer _____	Registration No. _____				
Order No. _____	Signature of mechanic _____				
Change engine oil when engine is warm, renew oil filter cartridge <sup>1)</sup>		<input type="checkbox"/>	<input type="checkbox"/>	<input type="checkbox"/>	<input type="checkbox"/>
Change oil in manual transmission and rear wheel drive when at operating temperature		<input type="checkbox"/>		<input type="checkbox"/>	<input type="checkbox"/>
Retighten cylinder head nuts		<input type="checkbox"/>			
Adjust valve clearance		<input type="checkbox"/>	<input type="checkbox"/>	<input type="checkbox"/>	
Check spark plugs			<input type="checkbox"/>		
Renew spark plugs				<input type="checkbox"/>	
Renew fuel filter <sup>3) *</sup>				<input type="checkbox"/>	
Check battery acid level, if necessary top up with distilled water				<input type="checkbox"/>	<input type="checkbox"/>
Clean and grease battery terminals				<input type="checkbox"/>	<input type="checkbox"/>
Renew intake air cleaner <sup>2)</sup>				<input type="checkbox"/>	
Check throttle cables for free movement, abrasion and kinking, renewing if necessary <sup>*</sup>		<input type="checkbox"/>	<input type="checkbox"/>	<input type="checkbox"/>	
Check clutch clearance, adjust if necessary		<input type="checkbox"/>	<input type="checkbox"/>	<input type="checkbox"/>	
Adjust Poly-V-belt [► SI 12 020 95 (700)] <sup>4) 5)</sup>		<input type="checkbox"/>	<input type="checkbox"/>	<input type="checkbox"/>	
Retighten hose clips at intake pipe		<input type="checkbox"/>			
Check brake pads and discs for wear, renew if necessary <sup>*</sup>			<input type="checkbox"/>	<input type="checkbox"/>	
Check front/rear brake fluid level, top up if necessary <sup>*</sup> [► SI 00 027 95 (716)]		<input type="checkbox"/>	<input type="checkbox"/>	<input type="checkbox"/>	
Check brake system with regard to function, leaks; repair/renew as required <sup>*</sup>				<input type="checkbox"/>	
<b>Renew brake fluid at least once a year</b>					<input type="checkbox"/>
Check wheel bearings, renew if necessary <sup>*</sup>				<input type="checkbox"/>	
Check swinging arm bearing (no play), adjust if necessary <sup>*</sup>		<input type="checkbox"/>	<input type="checkbox"/>	<input type="checkbox"/>	
Check steering damper (R850/1100R)			<input type="checkbox"/>	<input type="checkbox"/>	
Lubricate side stands, centre stand (R 1100 RS) and nipple for clutch cable assembly			<input type="checkbox"/>	<input type="checkbox"/>	<input type="checkbox"/>
Check side stand switch for damage and correct operation [► SI 46 033 96 (722)]		<input type="checkbox"/>	<input type="checkbox"/>	<input type="checkbox"/>	<input type="checkbox"/>
Check fit of rear wheel bolts		<input type="checkbox"/>			
Check bolts of control arm to specified torque		<input type="checkbox"/>			
Clean and grease shaft for windshield adjustment (R 1100 RS)				<input type="checkbox"/>	
Grease lower eye of front spring strut (R 1100 RS slide bearing)			<input type="checkbox"/>	<input type="checkbox"/>	
Check idle speed, throttle synchronisation and CO value, adjust if necessary		<input type="checkbox"/>	<input type="checkbox"/>	<input type="checkbox"/>	<input type="checkbox"/>
Final inspection with safety/operating check:					
– condition of tyres and wheels, rims and spokes, tyre pressures		<input type="checkbox"/>	<input type="checkbox"/>	<input type="checkbox"/>	<input type="checkbox"/>
– lights and signal systems					
– telltale and warning lights					
– clutch and gear shift					
– handbrake and footbrake, steering					
– instruments					
– test ride, if necessary					

1) for short-distance driving or outside temperatures below 0°C every 3 months, every 3,000 km (1,800 miles) at the latest

2) in very dirty or dusty conditions, renew the intake air cleaner element every 10,000 km (6,000 miles), or even more frequently if necessary

3) normally every 40,000 km (24,000 miles), but if fuel is of poor quality every 20,000 km (12,000 miles)

4) Renew Poly-V-belt every 40,000 km (24,000 miles)

5) After 60,000 km (36,000 miles), change the maintainance free Poly-V-belt, do not adjust

<sup>\*</sup>) invoiced as a separate item



Customer _____	Registration No. _____	<b>BMW Pre-delivery check</b>
Order No. _____	Signature of mechanic _____	
Inspect crates on receipt for signs of damage		<input type="checkbox"/>
Motorcycle: <ul style="list-style-type: none"> <li>- unpack</li> <li>- check scope of delivery</li> <li>- install/complete</li> <li>- clean</li> </ul>		<input type="checkbox"/>
Battery: <ul style="list-style-type: none"> <li>- remove</li> <li>- add battery acid</li> <li>- charge</li> <li>- grease the terminal posts</li> <li>- re-install (mark date)</li> </ul>		<input type="checkbox"/>
Check complete specification delivery: <ul style="list-style-type: none"> <li>- tools</li> <li>- handbooks and documents</li> <li>- keys</li> <li>- optional extras</li> </ul>		<input type="checkbox"/>
Check headlight (basic setting), adjust if necessary		<input type="checkbox"/>
Check front and rear wheel brake fluid levels		<input type="checkbox"/>
Check torque setting of the rear wheel retaining studs		<input type="checkbox"/>
Check tyre pressure		<input type="checkbox"/>
Check engine oil level, top up if necessary		<input type="checkbox"/>
Fuel the motorcycle		<input type="checkbox"/>
Check basic clutch setting, adjust if necessary		<input type="checkbox"/>
Safety/operating check as final inspection: <ul style="list-style-type: none"> <li>- idle speed</li> <li>- clutch, gear shifting</li> <li>- steering</li> <li>- front and rear brakes</li> <li>- telltale and warning lights, instruments, lighting and signalling equipment</li> <li>- ABS</li> <li>- test ride, if necessary</li> </ul>		<input type="checkbox"/>





# 00 Maintenance and general instructions

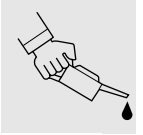

<b>Contents</b>	<b>Page</b>
<b>Tightening torques R 1100 RS / R 1100 RT</b> .....	3
<b>Tightening torques R 850/1100 GS und R 850/1100 R</b> .....	12
<b>Operating materials</b> .....	21
Key to maintenance intervals .....	22
<b>Change engine oil, renew oil filter element</b> .....	22
(Inspection I, II, III, IV) .....	22
<b>Change the oil in the gearbox and rear wheel drive</b> .....	23
(Inspection I, III, IV) .....	23
Changing oil in gearbox .....	23
Changing oil in rear wheel drive .....	23
<b>Checking battery acid level/topping up if necessary, cleaning/greasing battery posts</b> .....	24
(Inspection III, IV) .....	24
<b>Renewing air cleaner</b> .....	24
(Inspection III) .....	24
<b>Renewing fuel filter</b> .....	25
(Inspektion III) .....	25
<b>Checking/renewing spark plugs</b> .....	29
(Inspection II, III) .....	29
<b>Taking up slack at cylinder heads</b> .....	29
(Inspection I) .....	29
<b>Checking/adjusting valve operating clearances</b> .....	30
(Inspection I, II, III) .....	30
<b>Adjusting Poly-V belt</b> .....	31
(Inspection I, II, III) .....	31
<b>Renewing Poly-V belt (40 000 km/24 000miles)</b> .....	31
(renew maintenance-free belts every 60 000 km/36 000 miles) .....	31
<b>Checking brake pads and discs for wear/renewing</b> .....	32
(Inspection III) .....	32
(ABS: Inspection II, III) .....	32

# Contents

Page



Checking brake pads for wear .....	32
Renewing brake pads – front brake .....	32
[RS] Renewing brake pads - rear brake .....	33
[GS/R/RT] Renewing brake pads - rear brake .....	33
Checking brake discs for wear .....	33
<b>Checking brake fluid level/topping up</b> .....	33
(Inspection III) .....	33
<b>Bleeding/renewing the brake fluid using the handbrake lever/ brake pedal</b> .....	34
(Inspection III, IV) .....	34
Bleeding front brake circuit/renewing fluid .....	34
Bleeding rear brake circuit/renewing brake fluid .....	34
<b>Grease the centre stand [RS], side stand and clutch cable nipple</b> .....	35
(Inspection II, III, IV) .....	35
<b>[RS] Cleaning and greasing the windshield adjusting shaft</b> .....	35
(Inspection III) .....	35
<b>[RS] Grease front suspension strut at its lower attachment lug (version with plain bearing only)</b> .....	35
(Inspection II, III) .....	35
<b>Checking/adjusting clutch operating clearance</b> .....	36
(Inspection I, II, III) .....	36
<b>Checking tightness of rear wheel studs</b> .....	37
(Inspection I) .....	37
<b>[RS] Check tightness of screws at adjustable handlebar</b> .....	37
(Inspection I) .....	37
<b>[R] Check steering damper</b> .....	37
(Inspection II, III) .....	37
<b>Taking up slack on hose clips at intake stub pipen</b> .....	37
(Inspection I, III) .....	37
<b>Checking front wheel bearings/ checking tilt play at rear wheel</b> .....	37
(Inspection III) .....	37
<b>Checking swinging arm bearings, adjusting if necessary</b> .....	37
(Inspection I, II, III) .....	37
<b>Checking/adjusting throttle synchronisation and CO emission value</b> .....	38
(Inspection I, II, III, IV) .....	38
<b>Final inspection with road safety and functional check</b> .....	42
(Inspection I, II, III, IV) .....	42

## Tightening torques R 1100 RS / R 1100 RT

Model	R 1100 RS	R 1100 RT
<b>11 Engine</b>		
Connection	Nm	Nm
<b>Cylinder head</b>		
Tightening sequence:		
1. Tighten cylinder head nuts (oiled) crosswise	20	20
1.1 Tighten all nuts to correct torque for joint		
1.2 Tighten all nuts to correct angle 90°		
1.3 Tighten all nuts to correct angle 90°		
2. M 10 screw	40	40
3. M 6 screw	9	9
After 1000 km, tighten cylinder head nuts crosswise:		
1. Unfasten one nut		
2. Tighten one nut to initial value	20	20
3. Tighten nut to wrench angle 180°		
4. Unfasten/retighten M10 screw	40	40
Bearing cap on rocker shaft	15	15
Locknut on valve clearance adjusting screw	8	8
Cylinder head cover to cylinder head	8	8
Camshaft end cover to cylinder head	9	9
Air intake connection to cylinder head	9	9
<b>Camshaft</b>		
Chain sprocket to camshaft	65	65
Camshaft bearing cap	15	15
<b>Rotary breather</b>		
Vent line to alternator mount cover		
M 8 screw	20	20
Banjo screw	25	25
<b>Alternator mount cover</b>		
M 6 screw	9	9
M 8 screw	20	20
<b>Auxiliary shaft</b>		
Chain sprocket to crankshaft	10	10
Chainwheel to auxiliary shaft	70	70
Chain tensioner housing to engine block	9	9

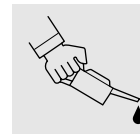

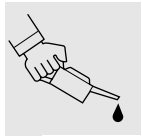

Model	R 1100 RS	R 1100 RT
<b>11 Engine</b>		
<b>Connection</b>	<b>Nm</b>	<b>Nm</b>
<b>Oil filter</b>		
Oil filter	11	11
Oil drain plug	32	32
<b>Oil pump</b>		
Mesh filter basket to engine block	9	9
Oil pump cover	9	9
Pressure relief valve	35	35
Oil pressure switch	30	30
<b>Oil cooler</b>		
Oil cooler pipe to engine block	10	10
Cooling oil line - banjo screw	25	25
Cooling oil line - banjo screw with oil vent valve	25	25
Oil lines to oil cooler	25	–
Oil cooler to holder	9	9
Oil cooler return line to engine block	35	35
Oil cooler feed line to frame	20	20
Oil cooler feed line to engine block	25	25
Screw-in union for oil cooler connection at engine block	35	35
	Clean threads and apply Loctite 603 to inner and outer threads and in the contact face area	
Oil cooler hose at oil thermostat	–	40
<b>Cylinders</b>		
Tightening sequence		
M 8 screw	20	20
M 6 screw	9	9
Chain guide rail pivot screw	18	18
<b>Timing chain</b>		
Chain tensioner	32	32
<b>Connecting rod</b>		
Big end cap	Joint torque	20
	Additional wrench angle 80°	20
<b>Crankcase</b>		
Tightening sequence:		
M 10 screw (oiled)	45	45
M 8 screw (oiled)	20	20
M 6 screw	9	9

Model	R 1100 RS	R 1100 RT
<b>12 Engine electrical system</b>		
Connection	Nm	Nm
Starter motor to engine	20	20
Starter cover to gearbox housing	7	-
Positive lead to starter motor	10	10
Alternator to alternator support cover	20	20
Tensioning and retaining strap at alternator	20	20
Spacer at alternator	20	20
Positive lead to alternator	15	15
Belt pulley at alternator	50	50
Belt pulley to crankshaft	50	50
Poly-V belt preload	8	8
Spark plug	20	20
<b>13 Fuel preparation and control</b>		
Temperature sensor on engine block	25	25
<b>16 Fuel tank and lines</b>		
Fuel tank to rear frame	22	22
Fuel pump assembly to tank	6	6
<b>18 Exhaust system</b>		
Muffler to footrest	35	35
Manifold to cylinder head (with strap)	22	22
(with jacket pipe)	18	18
Muffler to support plate for center stand	20	20
Clip on muffler	50	50
	Grease clamping face with Never Seez	
Oxygen sensor (lambda probe) to muffler	55	55
	Grease with Never Seez	

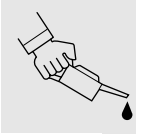



Model	R 1100 RS	R 1100 RT
<b>31 Front fork</b>		
Connection	Nm	Nm
Clamp between fixed tubes and fork bridge	22	–
Screw connection between fixed tube and fork bridge	–	45 (free from oil and grease)
Control arm to ball joint	130	130
	clean thread + Loctite 2701	
Fork bridge to ball joint	130	–
	clean threads + Loctite 2701	–
Threaded journal to frame	–	130
	–	clean threads + Loctite 243
Ball joint to fork slider tube bridge Frame	230	230
	230	–
Slider tube bridge to slider tube	22	–
	clean thread + Loctite 243	–
Screw plug to fixed fork tube	18	pressed fit, do not release
Clamping screws, quick-release axle	22	22
Control arm to engine	right 73	73
Screw cap	left 42	42
	apply light coat of Never Seez to thread	
Spring strut to frame	47	47
Spring strut to control arm	43 8.8 screw	43 8.8 screw
	50 10.9 screw	50 10.9 screw
<b>32 Steering</b>		
Handlebar at rubber mount	40	–
Rubber mount at fork bridge	40	–
Handlebar to fork bridge	–	21
Twistgrip to handlebar	7	7
Handlebar weight to fixed handlebar	20	–
Handlebar weight to handlebar	–	20
Handlebar weight to adjustable handlebar	7	7
	clean threads + Loctite 2701	–

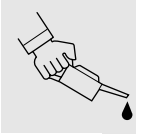



Model	R 1100 RS	R 1100 RT
<b>33 Rear wheel drive</b>		
Connection	Nm	Nm
Oil drain plug	23	23
Oil filler plug	23	23
Threaded ring	118 (Hylomar SQ 32 M)	118 (Hylomar SQ 32 M)
Hexagon nut, input bevel gear	200	200
	clean thread + Loctite 273	
Housing cover	35	35
Fixed bearing journal Swinging arm to gearbox/ Swinging arm at rear wheel drive	150	150
	clean thread + Loctite 2701	
Free bearing journal Swinging arm to gearbox/ Swinging arm at rear wheel drive	7	7
	clean thread + Loctite 2701	
Locknut on free bearing journal	105	105
	clean thread + Loctite 2701	
Strut at rear wheel drive / gearbox	43	43
	load motorcycle with approx. 85 kg and tighten loose strut	
Spring strut to rear frame / rear swinging arm	43 8.8 screw	43 8.8 screw
	50 10.9 screw	50 10.9 screw
Hydraulic spring adjuster at footrest plate	–	22



Model	R 1100 RS	R 1100 RT
<b>34 Brakes</b>		
Connection	Nm	Nm
Brake caliper to slider tube	40	40
Brake caliper to rear wheel drive	40	40
Brake disc to front wheel	21	21
Brake disc to rear wheel drive	21	21
	clean thread + Loctite 273	
Brake hose to brake caliper, front/rear	15	15
Brake hose to fitting	15	15
Brake hose to flow distributor	15	15
Flow distributor to frame	9	9
Flow distributor to slider tube bridge	9	9
Flow distributor to holder/slider tube	–	9
Bleed screw on front brake caliper	7	7
Bleed screw on rear brake caliper	7	4
Master cylinder to footrest plate	9	9
Brake pedal to footrest plate	37	37
Handbrake lever pivot pinl	8	8
	the Tuflok blue thread retaining agent can be slackened off and tightened several times if necessary	
ABS sensor	4 (handtight)	4 (handtight)
ABS unit to holder		
M6 screw	9	9
M6 screw (Torx)	5	5
Brake line to ABS unit	15	15
Bleed screw to ABS unit	9	9
<b>36 Wheels and tyres</b>		
Clamping screws, quick-release axle	22	22
Screw connection, quick-release axle	30	30
Screw on wheel nuts handtight, then tighten crosswise:		
Initial tightening	50	50
Final tightening	105	105

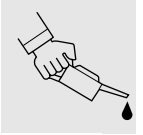



Model	R 1100 RS	R 1100 RT	
<b>46 Frame</b>			
Connection	Nm	Nm	
Rear frame to gearbox/engine Screw connection on right of gearbo at right of engine at left of engine at left of gearbox	47	47	
Footrest plate to gearbox	22	22	
Frame to engine	82	82	
Struts to frame	47 8.8 screw	47 8.8 screw	
	58 10.9 screw	58 10.9 screw	
Struts to engine	47	47	
Guard hoop to cylinder head	20	20	
Side stand to pivot mount	42	42	
	clean thread + Loctite 2701		
Center stand to carrier plate	21	21	
	clean thread + Loctite 2701		
Carrier plate for center stand to engine block M12 screw	72	72	
	clean thread + Loctite 2701		
	21	21	
	clean thread + Loctite 2701		
Grab handle to rear frame	9	9	
	Lifting handle to rear frame		
	10	10	
Footrest plate to rear frame	Footrest plate to rear frame		
	M 6 screw	9	-
	M 8 screw	21	21
	M 10 screw	42	-
Footrest to footrest plate	42	-	
Fairing support bracket to frame	20	20	

Model	R 1100 RS	R 1100 RT
<b>51 Equipment</b>		
Connection	Nm	Nm
Ignition/steering lock to fork bridg	15	15
<b>61 General electrical system</b>		
Horn to horn bracket	8	20
Ground (earth) strap to engine block	10	10
Rubber bushing for battery holder at gearbox	4	4

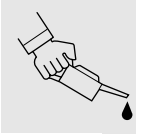

## Tightening torques R 850/1100 GS und R 850/1100 R



Model	R 850/1100 GS	R 850/1100 R
<b>11 Engine</b>		
Connection	Nm	Nm
<b>Cylinder head</b>		
Tightening sequence:		
1. Tighten cylinder head nuts (oiled) crosswise	20	20
1.1 Tighten all nuts to correct torque for joint		
1.2 Tighten all nuts to correct angle 90°		
1.3 Tighten all nuts to correct angle 90°		
2. M 10 screw	40	40
3. M 6 screw	9	9
After 1000 km, tighten cylinder head nuts crosswise:		
1. Unfasten one nut		
2. Tighten one nut to initial value	20	20
3. Tighten nut to wrench angle 180°		
4. Unfasten/retighten M10 screw	40	40
Bearing cap on rocker shaft	15	15
Locknut on valve clearance adjusting screw	8	8
Cylinder head cover to cylinder head	8	8
Camshaft end cover to cylinder head	9	9
Air intake connection to cylinder head	9	9
<b>Camshaft</b>		
Chain sprocket to camshaft	65	65
Camshaft bearing cap	15	15
<b>Rotary breather</b>		
Vent line to alternator mount cover		
M 8 screw	20	20
Banjo screw	25	25
<b>Alternator mount cover</b>		
M 6 screw	9	9
M 8 screw	20	20
<b>Auxiliary shaft</b>		
Chain sprocket to crankshaft	10	10
Chainwheel to auxiliary shaft	70	70
Chain tensioner housing to engine block	9	9

Model	R 850/1100 GS	R 850/1100 R
<b>11 Engine</b>		
<b>Connection</b>	<b>Nm</b>	<b>Nm</b>
<b>Oil filter</b>		
Oil filter	11	11
Oil drain plug	32	32
<b>Oil pump</b>		
Mesh filter basket to engine block	9	9
Oil pump cover	9	9
Pressure relief valve	35	35
Oil pressure switch	30	30
<b>Oil cooler</b>		
Oil cooler pipe to engine block	10	10
Cooling oil line - banjo screw	25	25
Cooling oil line - banjo screw with oil vent valve	25	25
Oil lines to oil cooler	25	-
Oil cooler to holder	9	9
Oil cooler return line to engine block	35	35
Oil cooler feed line to engine block	25	25
Screw-in union for oil cooler connection at engine block	35	35
	Clean threads and apply Loctite 603 to inner and outer threads and in the contact face area	
<b>Cylinders</b>		
Tightening sequence:		
1. M 8 screw	20	20
2. M 6 screw	9	9
3. Chain guide rail pivot screw	18	18
<b>Timing chain</b>		
Chain tensioner	32	32
<b>Connecting rod</b>		
Big end cap	Joint torque	20
	Additional wrench angle	80°
20		20
<b>Crankcase</b>		
Tightening sequence:		
1. M 10 screw (oiled)	45	45
2. M 8 screw (oiled)	20	20
3. M 6 screw	9	9

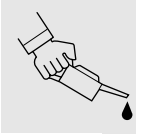

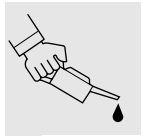

Model	R 850/1100 GS	R 850/1100 R
<b>12 Engine electrical system</b>		
Connection	Nm	Nm
Starter motor to engine	20	20
Starter cover to gearbox housing	7	7
Positive lead to starter motor	10	10
Alternator to alternator support cover	20	20
Tensioning and retaining strap at alternator	20	20
Spacer at alternator	20	20
Positive lead to alternator	15	15
Belt pulley at alternator	50	50
Belt pulley to crankshaft	50	50
Poly-V belt preload	8	8
Spark plug	20	20
<b>13 Fuel preparation and control</b>		
Temperature sensor on engine block	25	25
<b>16 Fuel tank and line</b>		
Fuel tank to rear frame	22	22
Fuel pump assembly to tank	6	6
Strut to tank	–	15
<b>18 Exhaust system</b>		
Muffler to rear frame	24	24
Manifold to cylinder head	(with strap) 22	22
	(with jacket pipe) 18	18
Muffler to support plate for center stand	20	20
Clip on muffler	50	50
	Grease clamping face with Never Seez	
Oxygen sensor (lambda probe) to muffler	55	55
	Grease with Never Seez	

Model		R 850/1100 GS	R 850/1100 R
<b>21 Clutch</b>			
Connection		Nm	Nm
Clutch housing	Joint torque	40	40
		oil screw threads lightly	
	Additional wrench angle 32°		
Housing cover		18	18
Locknut on release lever		22	22
<b>23 Gearbox</b>			
Oil filler plug		23	23
Oil drain plug		23	23
Gearbox cover to gearbox housing		9	9
Screw for neutral detent		13	13
		clean thread + Loctite 243	
Oil guide plate at gearbox housing		9	9
		clean thread + Loctite 573, also apply Loctite 573 to sealing face between oil baffle plate and gearbox housing	
Gearbox to engine block		22	22
Clutch lever to gearbox housing		18	18
Selector lever to selector shaft		9	9
Pedal to footrest plate		35	35

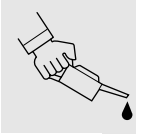



Model	R 850/1100 GS	R 850/1100 R
<b>31 Front fork</b>		
Connection	Nm	Nm
Screw connection between fixed tube and fork bridge	45 (free from oil and grease)	45 (free from oil and grease)
Control arm to ball joint	130	130
	clean thread + Loctite 2701	
Threaded journal to frame	130	130
	clean threads + Loctite 243	
Ball joint to fork slider tube bridge	230	230
Slider tube bridge to slider tube	22	22
	clean threads + Loctite 243	
Screw plug to fixed fork tube	press fit, do not release!	
Clamping screws, quick-release axle	22	22
Control arm to engine	right 73	73
Screw cap	left 42	42
	apply light coat of Never Seez to thread	
Spring strut to frame	47	47
Spring strut to control arm	50 10.9 screw	50 10.9 screw
Steering damper to fork slider bridge mount	–	20 clean thread + Loctite 2701
Steering damper mount to fork slider bridge	–	9 clean thread + Loctite 2701
Steering damper to leading link pivot mount	–	20 clean thread + Loctite 2701
Steering damper pivot mount at leading link	–	20
Joint head against locknut	–	20



Model	R 850/1100 GS	R 850/1100 R
<b>32 Steering</b>		
Connection	Nm	Nm
Handlebar to fork bridge	21	21
Twistgrip to handlebar	7	7
Handlebar weight to fixed handlebar	20	20
<b>33 Rear wheel drive</b>		
Oil drain plug	23	23
Oil filler plug	23	23
Threaded ring	118 (Hylomar SQ 32 M)	118 (Hylomar SQ 32 M)
Hexagon nut, input bevel gear	200	200
	clean thread + Loctite 273	
Housing cover	35	35
Fixed bearing journal Swinging arm at gearbox Swinging arm at rear wheel drive	150	150
	clean thread + Loctite 2701	
Free bearing journal Swinging arm to gearbox/ Swinging arm to rear wheel drive	7	7
	clean thread + Loctite 2701	
Locknut on free bearing journal	105	105
	clean thread + Loctite 2701	
Strut at rear wheel drive / gearbox	43	43
	(load motorcycle with approx. 85 kg and tighten loose strut)	
Spring strut to rear frame / rear swinging arm	50 10.9 screw	50 10.9 screw
Hydraulic spring adjuster at footrest plat	22	-

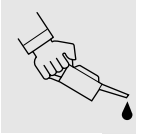



Model	R 850/1100 GS	R 850/1100 R
<b>34 Brakes</b>		
Connection	Nm	Nm
Brake caliper to slider tube	40	40
Brake caliper to rear wheel drive	40	40
Brake disc to front wheel Cast wheel Spoked wheel	– 24	21 24
	clean thread + Loctite 243	
Brake disc to rear wheel drive	21	21
	clean thread + Loctite 273	
Brake disc to rear wheel	21	21
	clean thread + Loctite 243	
Brake hose to brake caliper, front/rear	15	15
Brake hose to fitting	15	15
Brake hose to flow distributor	15	15
Flow distributor to frame	9	9
Flow distributor to slider tube bridge	9	–
Flow distributor to holder/slider tube	–	9
Bleed screw on front brake caliper	7	7
Bleed screw on rear brake caliper	4	4
Master cylinder to footrest plate	9	9
Brake pedal to footrest plate	37	37
Handbrake lever pivot pin	8	8
	(the Tuflok blue thread retaining agent can be slackened off and tightened several times if necessary)	
ABS sensor	4 (handtight)	4 (handtight)
ABS unit to holder		
M6 screw	9	9
M6 screw (Torx)	5	5
Brake line to ABS unit	15	15
Bleed screw to ABS unit	9	9

Model	R 850/1100 GS	R 850/1100 R
<b>36 Wheels and tyres</b>		
Connection	Nm	Nm
Clamping screws, quick-release axle	22	22
Screw connection, quick-release axle	30	30
Screw on wheel nuts handtight, then tighten crosswise:		
Initial tightening	50	50
Final tightening	105	105
<b>46 Frame</b>		
Rear frame to gearbox/engine	47	47
1. Screw connection on right of gearbox		
2. at right of engine		
3. at left of engine		
4. at left of gearbox		
Footrest plate to gearbox	22	22
Frame to engine	82	82
Struts to frame	47 8.8 screw	47 8.8 screw
	58 10.9 screw	58 10.9 screw
Struts to engine	58	58
Guard hoop to cylinder head	20	20
Side stand to pivot mount	42	42
	clean thread + Loctite 2701	
Center stand to carrier plate	21	21
	clean thread + Loctite 2701	
Carrier plate for center stand to engine block	M12 screw	72
	clean thread + Loctite 2701	
	M 8 screw (countersunk)	21
	clean thread + Loctite 2701	
Footrest plate to rear frame	M 8 screw	21
Fairing support bracket to frame	20	-

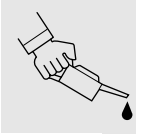



Model	R 850/1100 GS	R 850/1100 R
<b>51 Equipment</b>		
Connection	Nm	Nm
Ignition/steering lock to fork bridge	15	15
<b>61 General electrical system</b>		
Horn to horn bracket	8	8
Ground (earth) strap to engine block	10	10
Rubber bushing for battery holder at gearbox	4	4

## Operating materials

Item	Use	Order number	Quantity
<b>Lubricant</b>			
Optimoly MP 3	High-performance lubricating paste	07 55 9 062 476	100 g tube
Optimoly TA	High-temperature assembly paste	18 21 9 062 599	100 g tube
Silicone grease 300, heavy	Damping grease	07 58 9 058 193	10 g tube
Retinax A	(Taper) roller bearing grease	81 22 9 407 710	100 g tube
Contact spray	Contact spray	81 22 9 400 208	300 ml aerosol
<b>Sealants</b>			
3-Bond 1209	Surface sealant	07 58 9 062 376	30 g tube
Loctite 574	Surface sealant	81 22 9 407 301	50 ml tube
Curil K 2	Heat-conductive sealant	81 22 9 400 243	250 g can
Hylomar SQ 32 M	Permanently elastic sealant	81 22 9 400 339	100 g tube
<b>Adhesives and retaining agents</b>			
Loctite 648	Structural adhesive, ultra-high speed	07 58 9 067 732	5 g bottle
Loctite 638	Joint connector	07 58 9 056 030	10 ml bottle
Loctite 243	Thread retainer, medium-strength	07 58 9 056 031	10 ml bottle
Loctite 270	Thread retainer, strong	81 22 9 400 086	10 ml bottle
Loctite 2701	Thread retainer	33 17 2 331 095	10 ml bottle
Loctite 454	Cyanacrylate adhesive	07 58 9 062 157	20 g tube
3-Bond 1110 B	Joint adhesive	07 58 9 056 998	5 g tube
<b>Cleaner</b>			
Brake cleaner	Brake cleaner	81 22 9 407 704	600 ml aerosol
<b>Testing agent</b>			
Penetrant MR 68	Crack testing agent for aluminum housings	81 22 9 407 494	500 ml spray
Entwickler MR 70	Developer for aluminum housing crack testing agent	81 22 9 407 495	500 ml spray

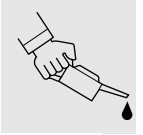

## Key to maintenance intervals

- Inspection at 1000 km (600 miles) **I**
- BMW Service **II**
- BMW Inspection **III**
- Annual Service **IV**



## Change engine oil, renew oil filter element

(Inspection I, II, III, IV)

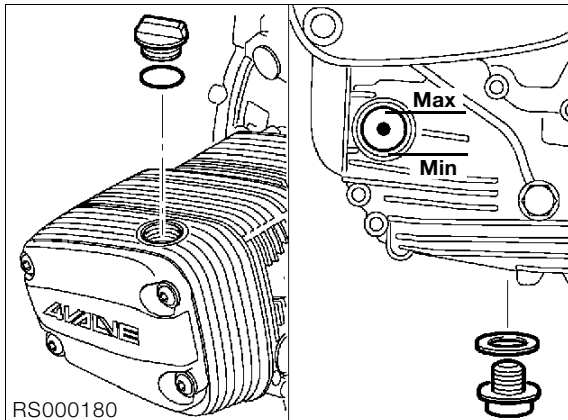

- Remove screw plug.
- Unscrew oil drain plug and drain off oil.
- Fit new seal and screw in drain plug.

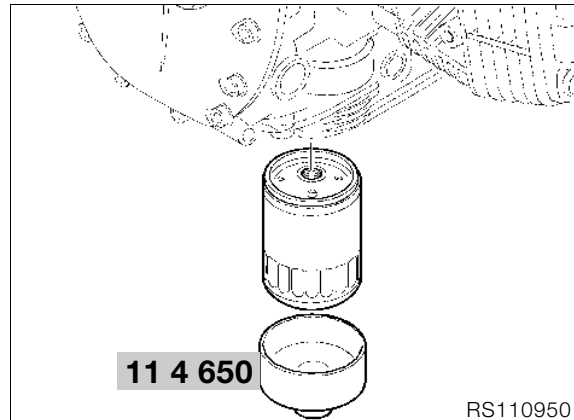

- Using oil filter wrench, **BMW No. 11 4 650**, unscrew and remove the oil filter element.
- Coat sealing ring on new oil filter element with oil and screw in.
- Top up oil/seal off.
- Do not check oil level until at least 10 minutes after test run/test ride.



### Caution:

Never add engine oil above the MAX mark.



### Tightening torque:

Oil filter ..... 11 Nm  
Oil drain plug ..... 32 Nm

### Fill quantity for engine:

- with oil filter change ..... 3.75 l (6.6 Imp. pints)  
- without oil filter change ..... 3.50 l (6.2 Imp. pints)  
Oil volume between  
MIN and MAX marks ..... 0.50 l (0.88 Imp. pints)

### Engine oil grade:

Brand-name HD oil for four-stroke spark-ignition engine, API classifications SE,SF,SG; combination with CC or CD specification.

## Change the oil in the gearbox and rear wheel drive

(Inspection I, III, IV)

Changing oil in gearbox

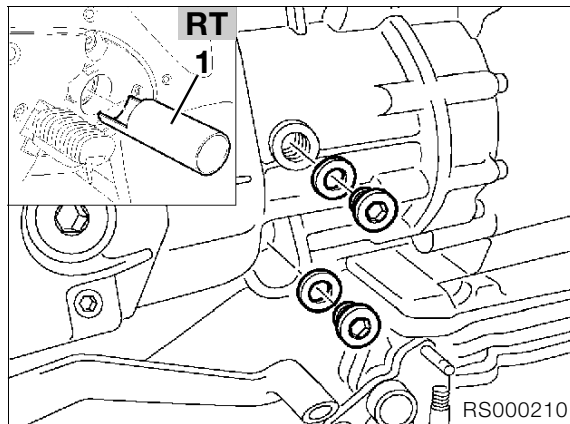

- **[RT]** Push in oil drain pipe (1), **BMW No. 23 4 680** and turn to right.
- Unscrew and remove oil filler plug and oil drain plug/drain off oil.
- Fit new seal and screw in drain plug.
- Top up gearbox oil.
- Insert oil filler plug with new seal.

### **Tightening torque:**

Oil drain plug .....	23 Nm
Oil filler plug .....	23 Nm

### **Fill quantity::**

gearbox up to lower rim of filler hole	
Initial filling .....	1.0 l (1.76 Imp. pints)
During oil changes .....	0.8 l (1.4 Imp. pints)

Changing oil in rear wheel drive

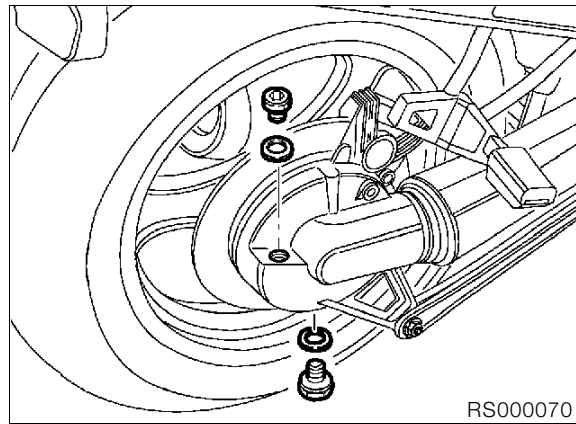

- Unscrew and remove oil filler plug and oil drain plug/drain off oil.
- Fit new seal and screw in drain plug.
- Top up gearbox oil.
- Insert oil filler plug with new seal.

### **Tightening torque:**

Oil drain plug .....	23 Nm
Oil filler plug .....	23 Nm

### **Fill quantity:**

Initial filling .....	0.25 l (0.44 Imp. pints)
During oil changes .....	0.23 l (0.404 Imp. pints)

### **Oil grade:**

Brand-name hypoid gear oil, SAE 90, API class GL 5

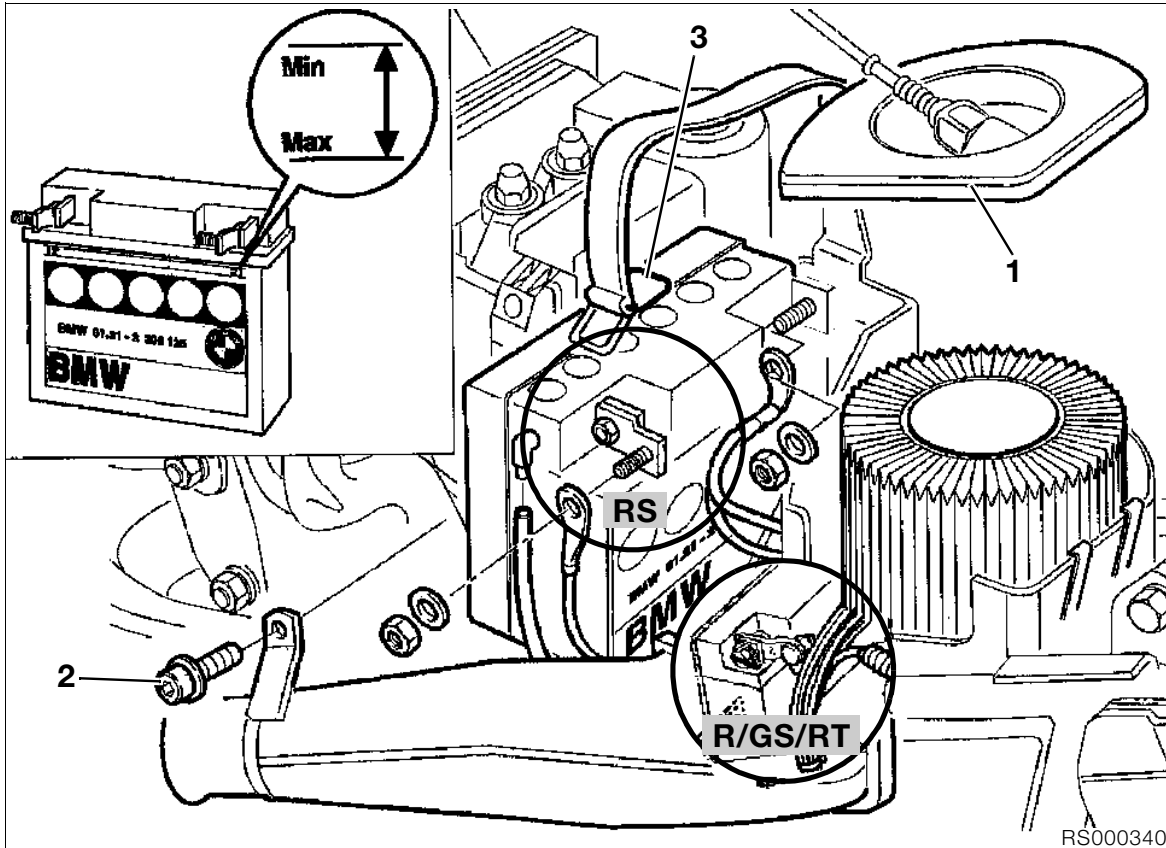

### Checking battery acid level/topping up if necessary, cleaning/greasing battery posts

#### (Inspection III, IV)

- Remove dualseat.
- **[RS/RT]** Take off left side fairing.
- **[GS]** Take off right side fairing.
- **[R]** Remove tank cover.
- Remove air cleaner cover (1).
- Remove intake air pipe (2).
- **[GS/R]** Unscrew fuel tank fastenings.
- **[GS/R]** Raise rear of fuel tank and support with a suitable object.
- Release the rubber battery strap (3).
- Remove battery.



#### Caution:

Disconnect negative terminal of battery first, then positive terminal. Connect positive battery terminal first, then negative terminal.

- Top up battery acid level with distilled water as far as the MAX mark.
- Installation in reverse order.

#### Protective battery-post grease:

e.g. Bosch Ft 40 V1



#### Tightening torque:

Fuel tank to rear frame ..... 22 Nm

### Renewing air cleaner

#### (Inspection III)

- Remove dualseat.
- **[GS]** Detach fuel tank at rear, raise it and support it with a suitable object.
- Renew air cleaner insert.



#### Tightening torque:

Fuel tank to rear frame ..... 22 Nm



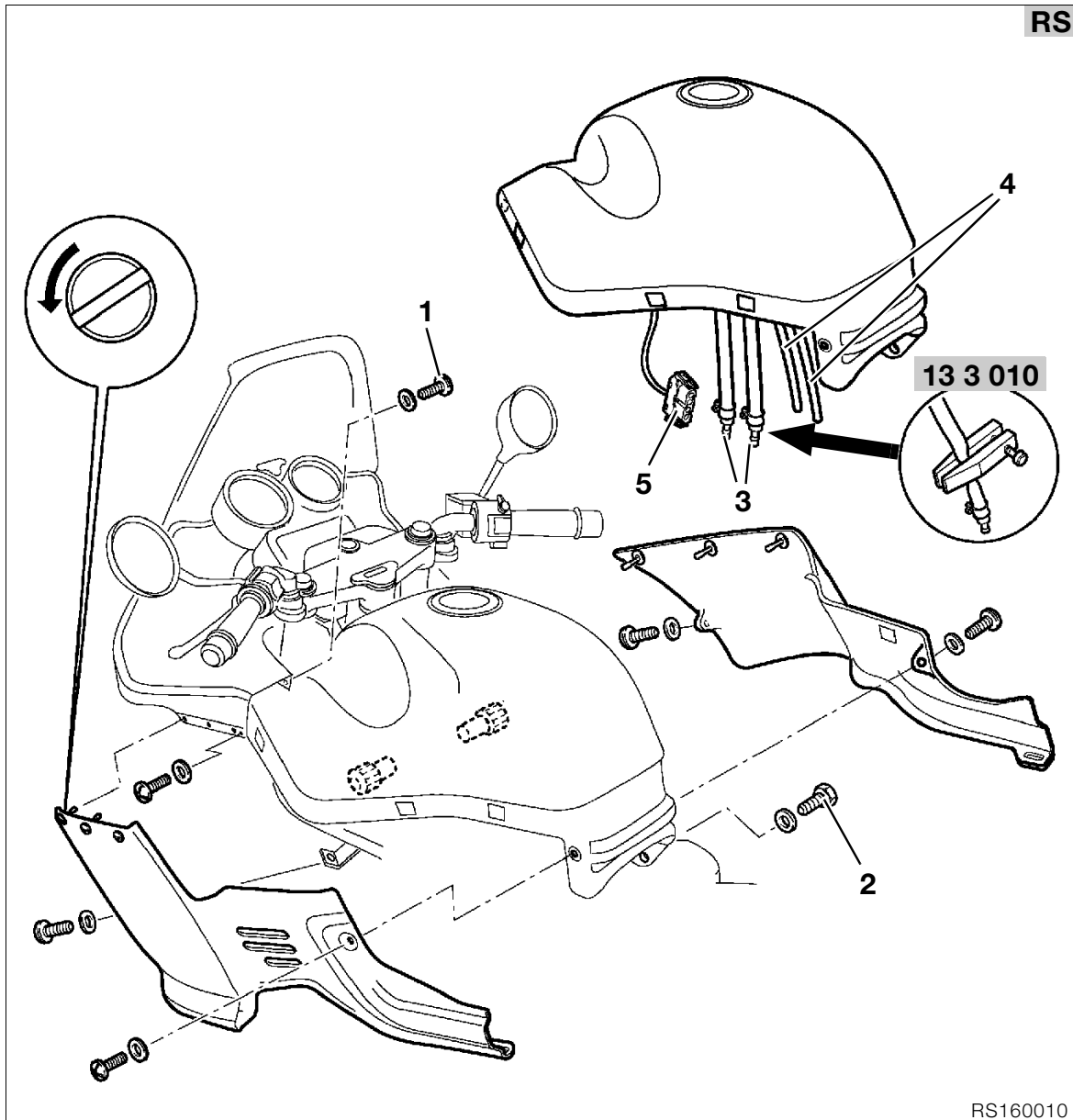

## Renewing fuel filter

### (Inspektion III)

- Remove dualseat.
- **[RS/RT]** Take off side sections of fairing.
- **[RS]** Detach cockpit inner panel (1) at fuel tank.
- **[GS]** Remove right side fairing.
- **[R]** Remove fuel tank cover.
- **[RT]** Detach storage compartment
- Unfasten fuel tank mount (2)
- Seal off fuel feed and return line (3) with hose clip, **BMW No. 13 3 010**, loosen and pull off.
- Remove vent pipes (4).
- Remove fuel pump connector (5).
- Lift off fuel tank.

RT

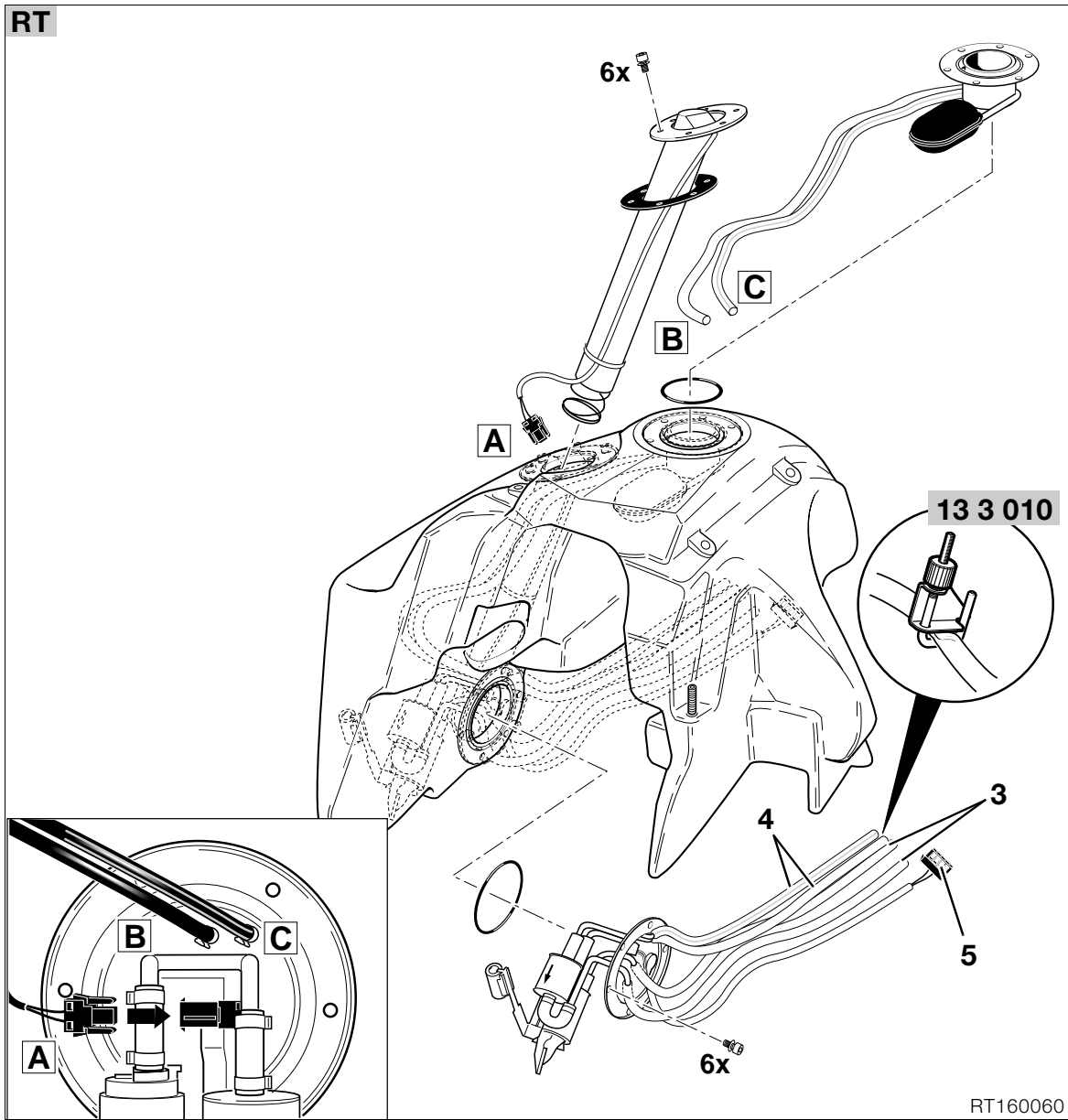

RT160060

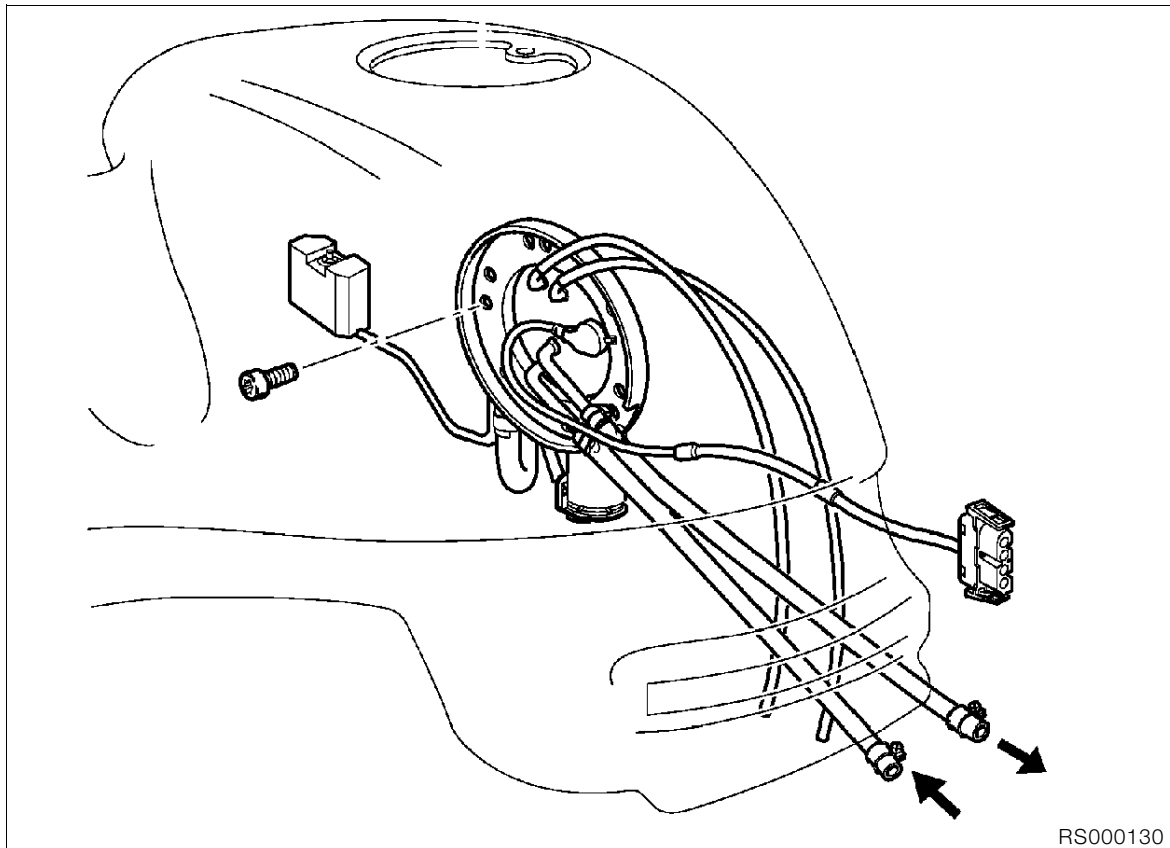

**⚠ Caution:**

Fuel is flammable and a hazard to health. Observe relevant safety regulations.

- Drain fuel tank.
- Remove fuel pump unit/detach vent hoses.

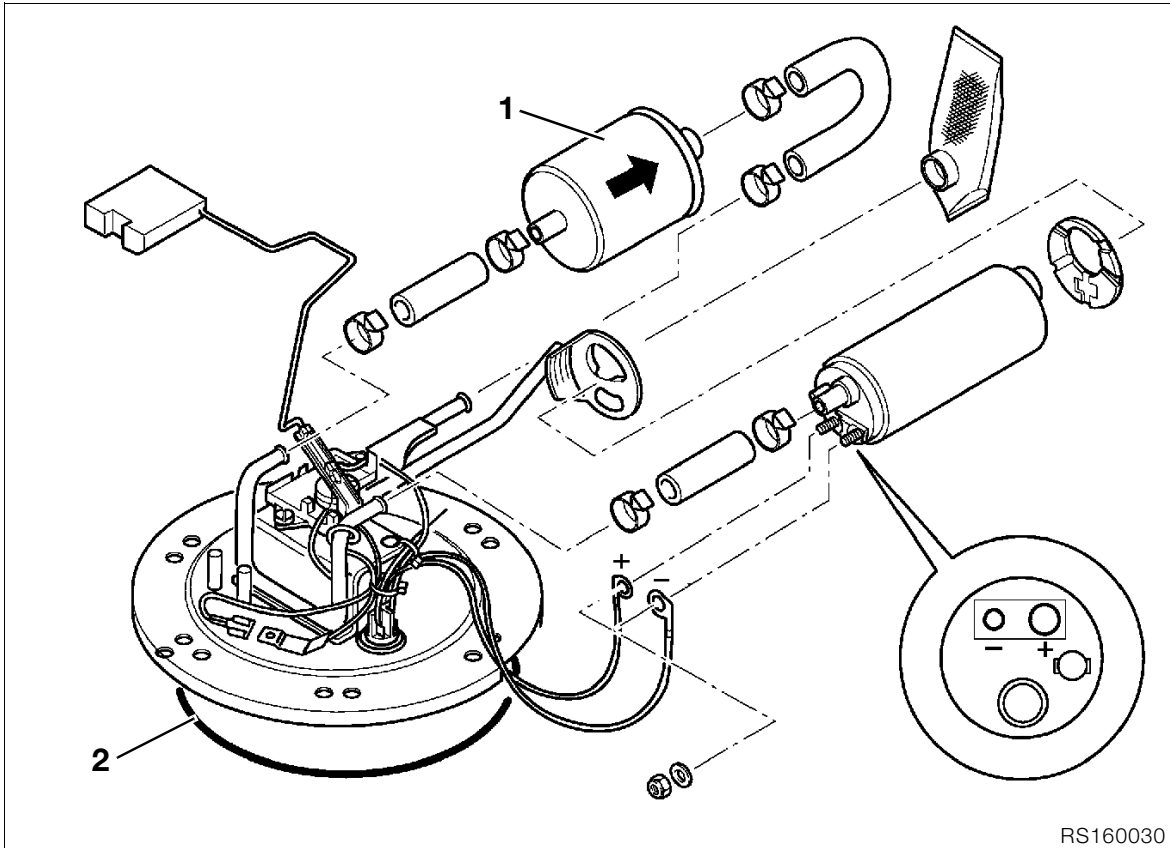

RS160030

- Detach hoses from fuel filter (1)
- Fit new fuel filter.
- Installation in reverse order.
- Secure non-reusable hose clips with pliers, **BMW No. 13 1 500.**



**Caution:**

Note correct direction of flow through fuel filter. Use only an O-ring seal (2) in good condition. After assembly, check fuel pump unit for leaks.



**Tightening torqu**

Fuel tank to rear frame ..... 22 Nm  
Fuel pump unit to fuel tank ..... 6 Nm

## Checking/renewing spark plugs

(Inspection II, III)

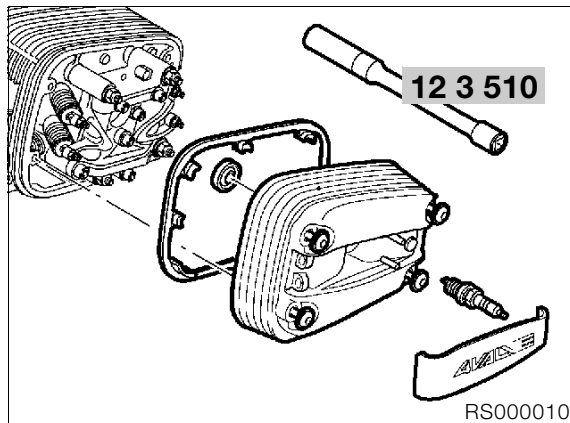

- Pull off spark plug cap with cap assembly tool, **BMW No. 12 3 520**.
- Unscrew and remove spark plugs with spark-plug wrench, **BMW No. 12 3 510**.

**Electrode gap:** ..... 0.8 mm (0.0315 in)

**Gap wear limit:** ..... 1.0 mm (0.04 in)



**Caution:**

Do not bend electrodes - risk of breakage!

## Taking up slack at cylinder heads

(Inspection I)

- Remove cylinder head cover.



**Caution:**

Trap escaping oil.

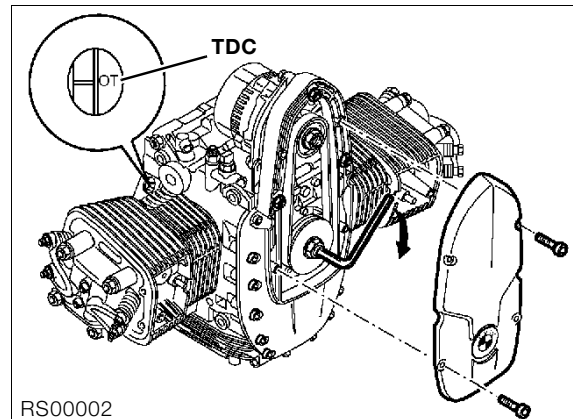

- Select a gear and turn the rear wheel, or set the piston to TDC by turning the belt pulley.

### Top dead centre on ignition stroke:

1. The OT (TDC) mark appears and
2. the inlet and exhaust valves of the cylinder in question are closed.

- Tighten cylinder head nuts.

### Tightening procedure after 1000 km ( 600 miles )

1. Tighten cylinder head nuts individually in a cross-wise pattern
  - 1.1. Slacken off one nut
  - 1.2. Tighten nut to init. torque ..... 20 Nm
  - 1.3. Tighten nut to specified wrench angle ..... 180°
2. Unfasten/retighten M10 screw ..... 40 Nm

## Checking/adjusting valve operating clearances

(Inspection I, II, III)

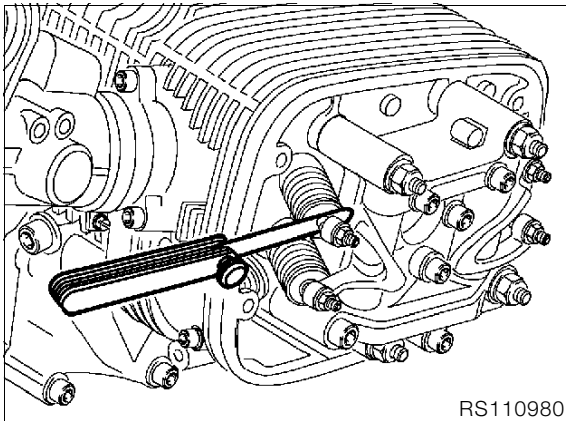

- Check valve clearance with feeler gauge and, if necessary, correct with adjusting nut/lock.

### Adjust valve clearances with the engine cold (max. 35°C):

Inlet ..... 0.15 mm ( 0.006 in )  
Exhaust ..... 0.30 mm (0.012 in )



#### ! Tightening torque:

Locknut ..... 8 Nm

- Check valve clearance again; it must be possible to insert the feeler gauge between valve stem and rocker with only slight resistance to movement.
- Assemble in reverse order



#### Caution:

Make sure that gasket is correctly seated. Gaskets and sealing faces must be free from oil or grease



#### ! Tightening torque

Cover screw ..... 8 Nm  
Spark plug (without lubricant) ..... 20 Nm

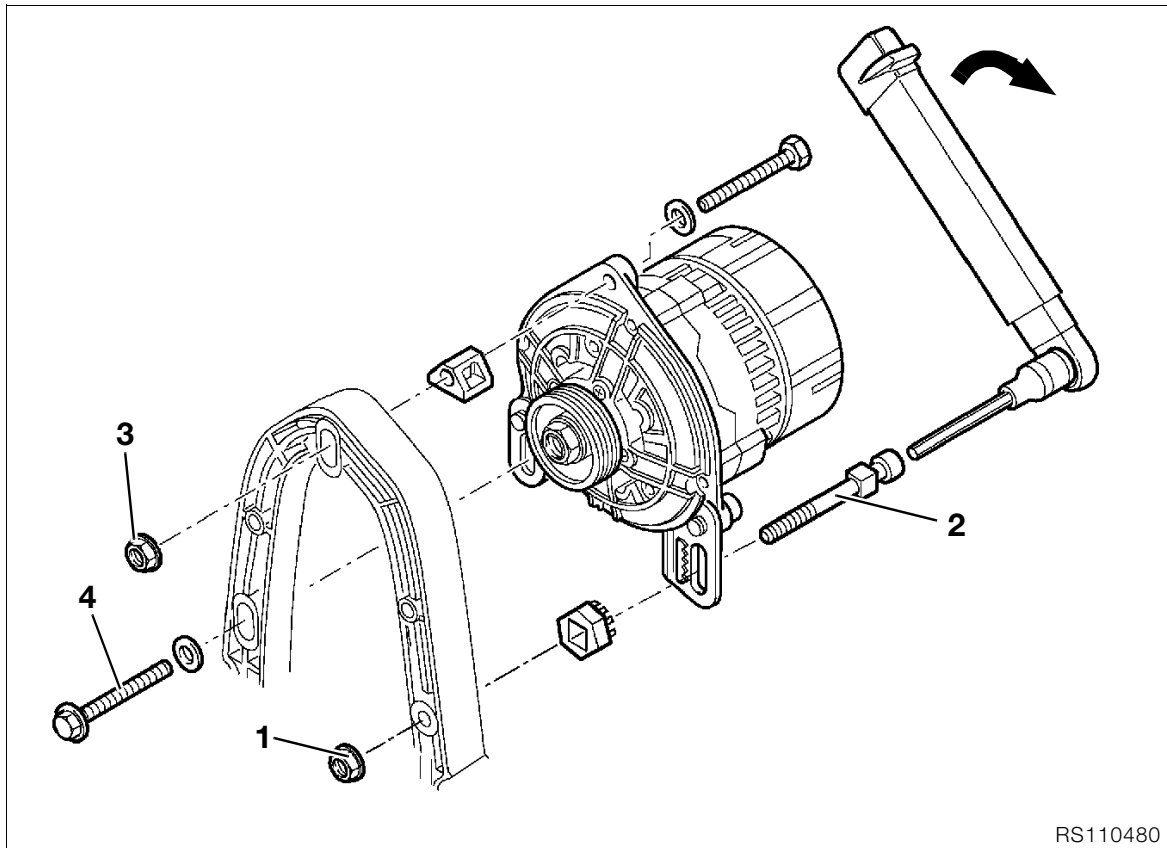

## Adjusting Poly-V belt

(Inspection I, II, III)

## Renewing Poly-V belt

(40 000 km/24 000miles)

(renew maintenance-free belts every 60 000 km/  
36 000 miles)

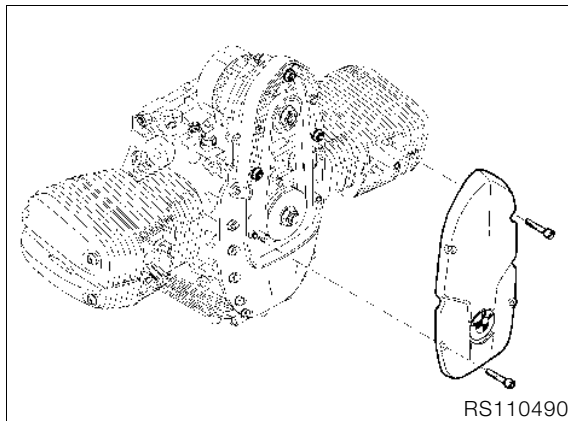

- **[RS/RT]** Remove left side fairing.
- **[R]** Remove left fuel tank cover.
- Remove front cover.
- Slacken off alternator mounting screws (1,3,4) and install a new Poly-V belt if necessary.

## Poly-V belt adjusting procedure:

### Poly-V belt installation procedure:

- Place the Poly-V belt in position, tension it and turn the engine over once, then release belt tension.

### Poly-V belt tensioning procedure:

- Screw hex nut (1) on adjusting screw (2) up handtight (**no tools to be used!**)
- Tighten adjusting screw (2) with a torque wrench, fully tighten retaining nut (3), slacken adjusting screw and tighten screws fully.

### ⚠ Tightening torque:

Poly-V belt preload..... 8 Nm  
Alternator to alternator support cover..... 20 Nm



### Note:

➔ See also Service Information 12 020 95 (700).

## Checking brake pads and discs for wear/renewing

(Inspection III)  
(ABS: Inspection II, III)

Checking brake pads for wear

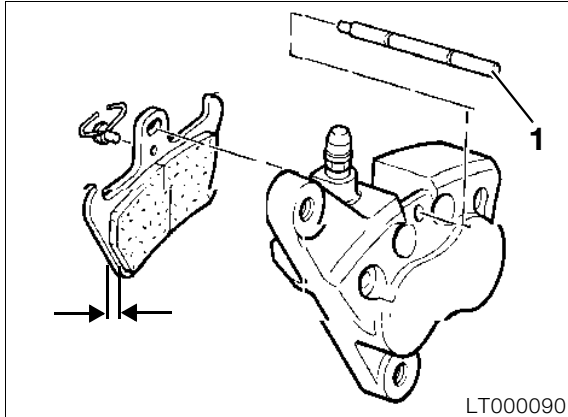

- [RS] Measure brake pad thickness (arrows).



- [GS/R/RT] Check wear marks.

### ⚠ Caution:

Brake pad thickness must not fall below the minimum value.

Change pads only as a complete set.

**Minimum lining thickness:** ..... 1.5 mm (0.059 in)

## Renewing brake pads – front brake

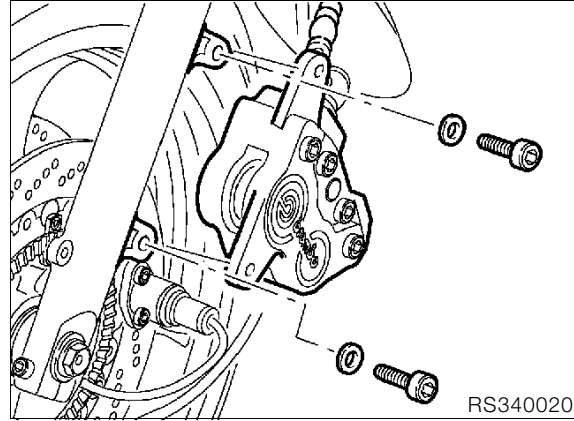

- Unfasten/remove brake caliper.

### ⚠ Caution:

[RS/R/RT] Do not scratch the wheel rim; mask it off with tape if necessary

- Remove keeper from retaining pin (1).
- Drive out retaining pin (1).
- Remove brake pads by pulling downwards.

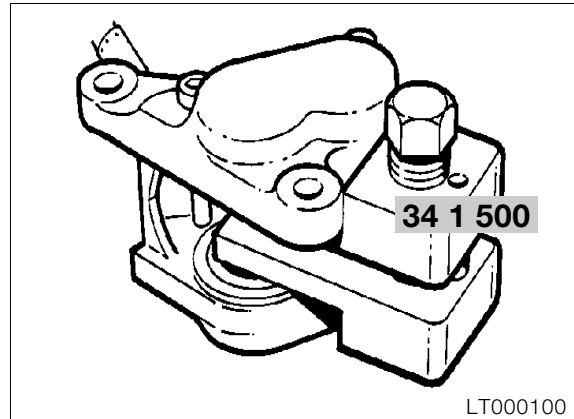

- Before installing the brake caliper, push the pistons back fully with resetting tool, **BMW No. 34 1 500**.
- Install in the reverse order of work.



### Tightening torque:

Brake caliper to rear wheel drive ..... 40 Nm



[RS] Renewing brake pads - rear brake

Checking brake discs for wear

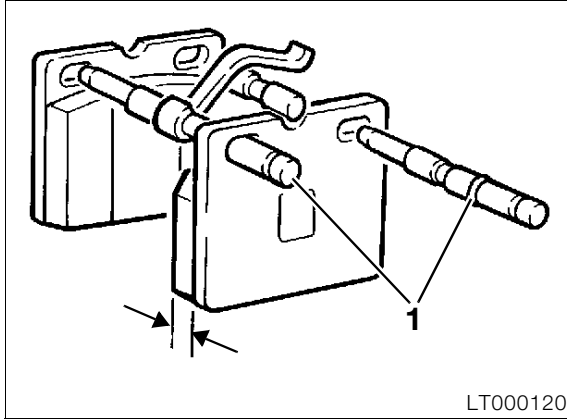

- Lever off cap from brake caliper.
- Drive out retaining pins (1), working from the wheel side.
- Lift brake pads upwards to remove.
- Install in the reverse order of work.
- If necessary, push pistons fully back with resetting tool, **BMW No. 34 1 500**.

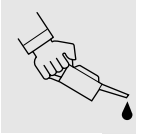
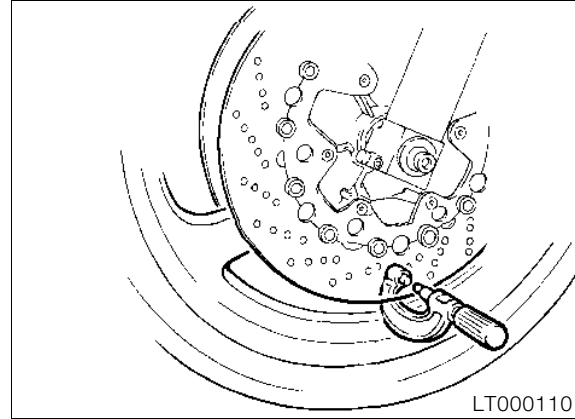

- Carefully inspect brake discs for cracking, damage, distortion, wear and scoring.

**Brake disc wear limit:**..... 4.5 mm (0.177 in)  
**[RS] rear:**..... 4.6 mm (0.181 in)

[GS/R/RT] Renewing brake pads - rear brake

**Checking brake fluid level/topping up**

(Inspection III)

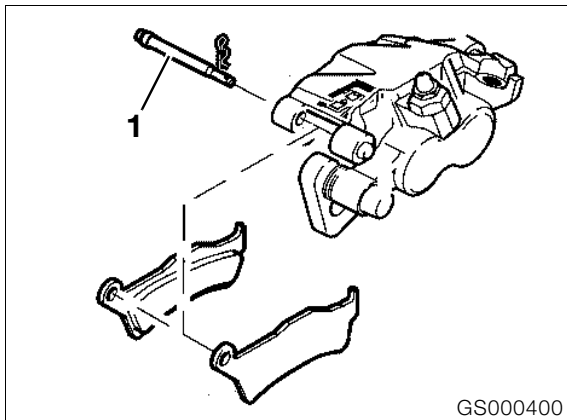

- **[RT]** Take out the rear wheel.
- Unfasten/remove brake caliper.
- Remove keeper from retaining pin (1).
- Drive out retaining pin (1) towards the wheel side.
- Remove brake pads.
- Before installing the brake caliper, depress the piston fully.
- Install in the reverse order of work.

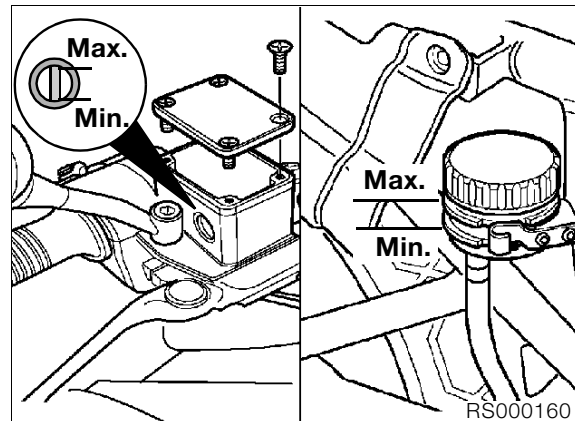

- Remove reservoir cover together with diaphragm.
- Add brake fluid up to the MAX mark.
- Fit diaphragm and reservoir cover.
- Carefully tighten retaining screws.

**Brake fluid grade:**  
 Use only brake fluid of DOT 4 quality classification (e.g. ATE "SL" brake fluid)

**! Tightening torque:**

Brake caliper at rear wheel drive: ..... 40 Nm

## Bleeding/renewing the brake fluid using the handbrake lever/brake pedal

(Inspection III, IV)



### Bleeding front brake circuit/renewing fluid

- Remove front brake pads.



#### Caution:

Do not tilt the brake calipers when removing. There is a risk of damage to the brake pads.

- Unscrew brake fluid reservoir cover and remove together with diaphragm.
- Add brake fluid up to the MAX mark.



#### Caution:

During the bleeding process, brake fluid level must not drop below the MIN mark, or else air will be drawn into the brake system.

If this occurs, repeat the bleeding operation.

- Connect a vessel to the brake caliper to trap brake fluid as it emerges from the bleed screw; slacken off the bleed plug by a half-turn.

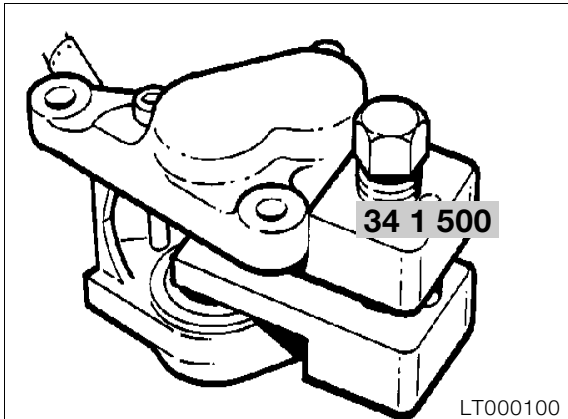

- Press the brake pistons fully back with the piston resetting tool, **BMW No. 34 1 500**.
- Remove the piston resetting tool and insert spacer, **BMW No. 34 1 520**, in its place.

- Press the pistons back in the second brake caliper, and leave the resetting tool in position.
- Apply handbrake lever several times until brake pressure can be detected.
- Maintain pressure on handbrake lever, then open bleed screw while maintaining firm pressure on the handbrake lever.



#### Caution:

Do not release the lever/pedal until the bleed screw has been closed.

- Close bleed screw and release handbrake lever.
- Allow brake fluid to emerge from both brake calipers in succession until it is clear and free from bubbles.
- Close bleed screw.
- Install brake pads/brake calipers.
- Brake fluid level = MAX mark.
- Fit diaphragm and reservoir cover.
- Carefully tighten retaining screws.
- Turn handlebar from lock to lock, actuating brake several times while doing so.
- Perform a functional check on the brake system.

### Bleeding rear brake circuit/renewing brake fluid

- **[RS/GS]** The rear brake caliper does not have to be removed, nor the pistons pushed back.
- **[R/RT]** To bleed, slacken off the brake caliper and position it so that the bleed nipple is at the highest point.
- After this, the procedure is the same as for bleeding/renewing the front brake fluid.

## Grease the centre stand [RS], side stand and clutch cable nipple

(Inspection II, III, IV)

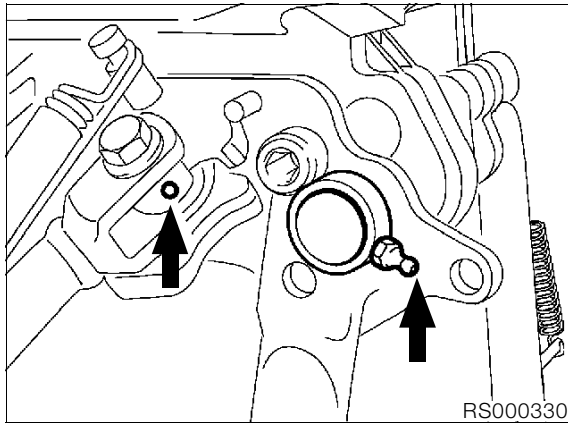

RS000330

- Clean and grease the nipple with a grease gun until grease starts to emerge at the bearing point.

**Lubricant:**..... e.g. Staburags NBU 30 PTM

## [RS] Cleaning and greasing the windshield adjusting shaft

(Inspection III)

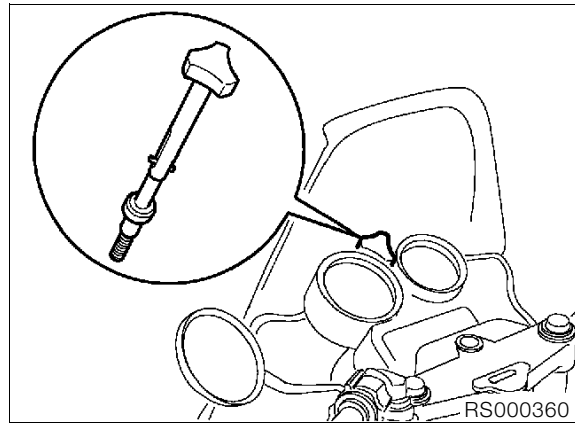

RS000360

- Unscrew, clean and grease the shaft, then screw it back in.

**Lubricant:**..... e.g. Shell Retinax A

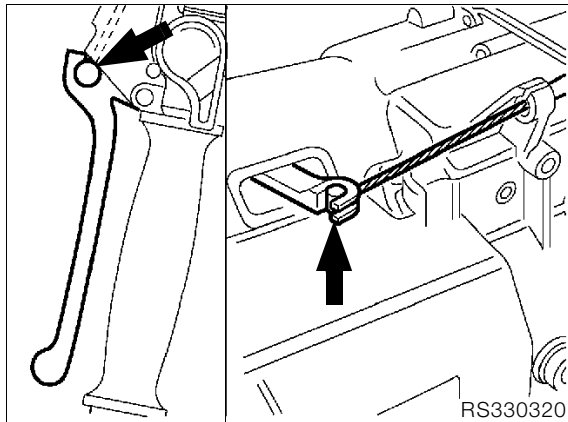

RS330320

## [RS] Grease front suspension strut at its lower attachment lug (version with plain bearing only)

(Inspection II, III)

**Lubricant:**..... e.g. Never Seeze

**Tightening torque:**  
Spring strut to control arm ..... 43 Nm

**Lubricant:**..... e.g. Shell Retinax A

## Checking/adjusting clutch operating clearance

(Inspection I, II, III)

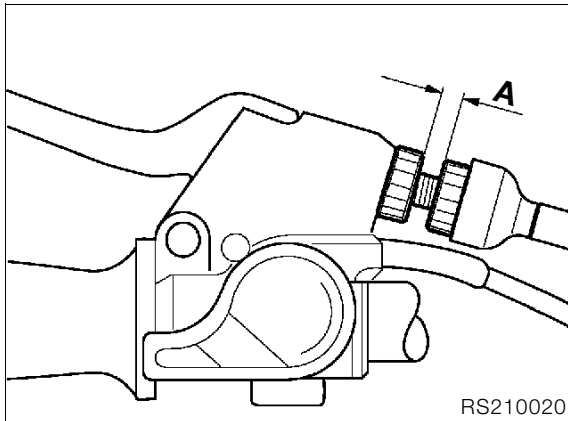

- Set distance A at the adjusting screw.

**Distance A:** ..... 12 mm (0.472 in)

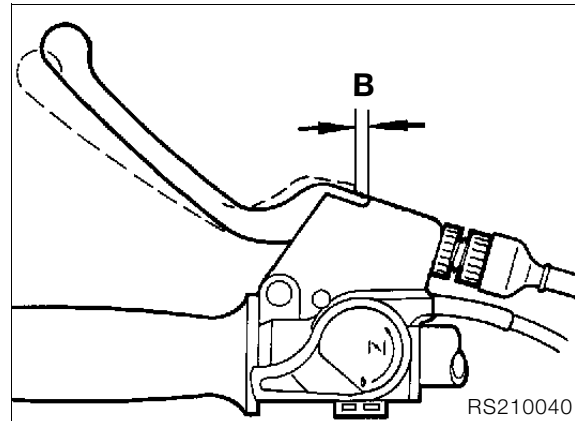

- Set to distance B at the handlebar clutch lever, using the adjusting screw on the release lever.

**Distance B:** ..... 7.0 mm (0.276 in)

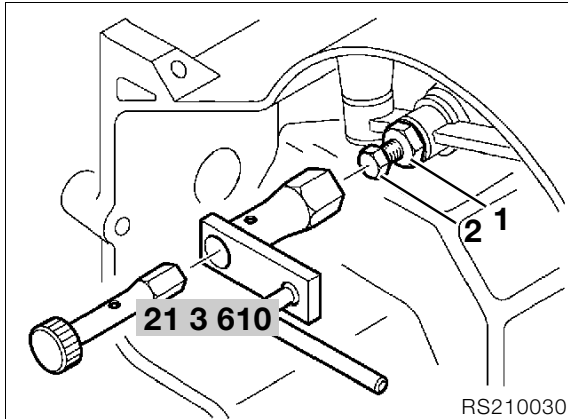

**Tightening torque:**  
Locknut on adjusting screw ..... 22 Nm

- **[GS]** If necessary, slacken off hydraulic spring adjuster with 6 mm Allen key, **BMW No. 31 5 600**.
- **[RT]** Slacken off the power socket holder.
- Using socket wrench, **BMW No. 21 3 610**, slacken off locknut (1) at adjusting screw (2) on the clutch release lever/gearbox.

## Checking tightness of rear wheel studs

(Inspection I)

 **Tightening torque:**  
Rear wheel nuts ..... 105 Nm

## [RS] Check tightness of screws at adjustable handlebar

(Inspection I)

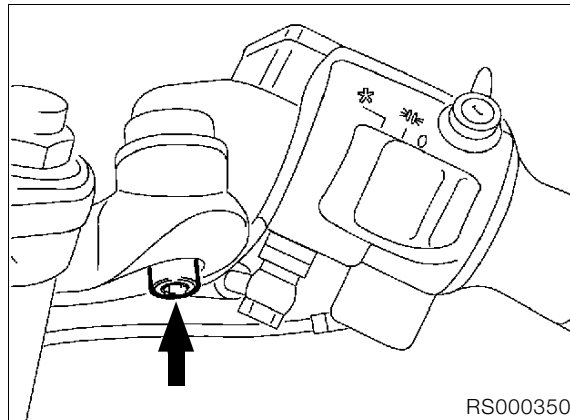

 **Tightening torque:**  
Handlebar adjusting screw ..... 20 Nm

## [R] Check steering damper

(Inspection II, III)

- Freedom from play at ball head.
- Freedom from play at piston rod.
- Turn steering to left and rock to and fro radially at front end of housing.

## Taking up slack on hose clips at intake stub pipe

(Inspection I, III)

 **Tightening torque:**  
Hose clips on air intake pipe ..... 2 Nm

## Checking front wheel bearings/ checking tilt play at rear wheel

(Inspection III)

- Relieve load on front wheel.
- Tilt the front wheel to and fro across the axle.
- No play should be detected.
- If play is detected in the wheel bearings, renew them.
- Tilt the rear wheel to and fro across the wheel axle.
- If play is detected, fit new shims to rear wheel drive or renew bearings.

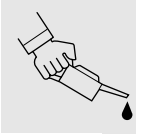

## Checking swinging arm bearings, adjusting if necessary

(Inspection I, II, III)

- Grip rear tyre and try to move it sideways, bracing against the frame.

## Checking/adjusting throttle synchronisation and CO emission value

(Inspection I, II, III, IV)

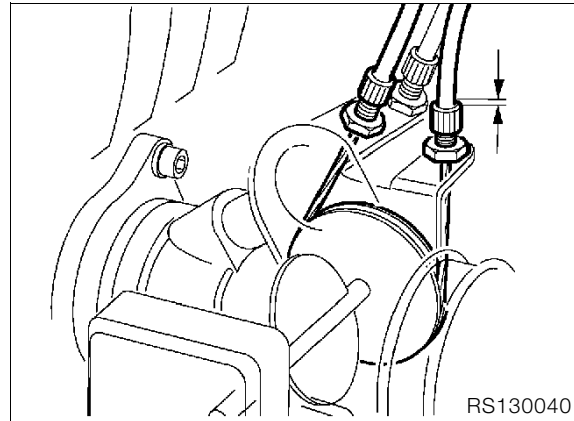
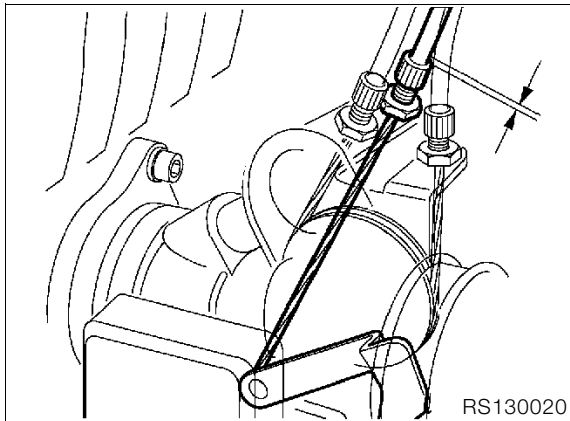

- **Pre-adjust** the wire connecting cable between the throttle stub pipes with the left or right adjusting screw .
- Adjust the connecting cable to zero play.

- **[RT]** Remove left side section of fairing.
- Adjust wire cable for increased idle speed (choke).

**Choke cable play:**..... < 1 mm (0.039 in)

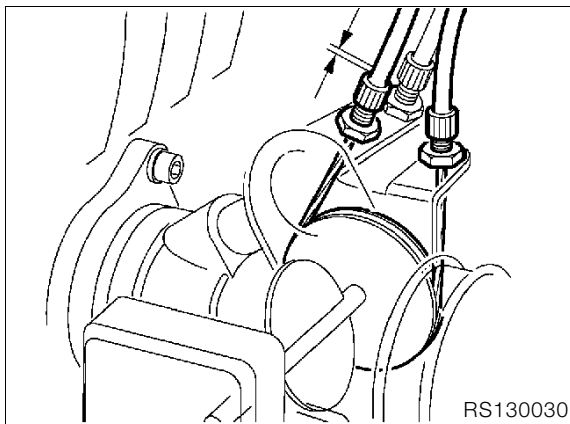

- Adjust the wire cable from the throttle twistgrip when the handlebar is on full right lock.

**Throttle cable play:**..... app. 0.5 mm (0.0197 in)

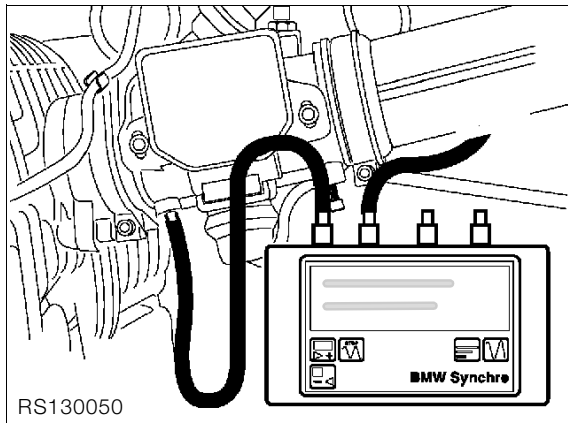

- **[RT]** Remove the flap at the bottom of the right fairing.
- Connect the BMW Synchrotester, **BMW No. 13 0 800**, to the vacuum bores in the throttle stub pipes.
- Ride the motorcycle until the engine is warm, or alternatively allow it to warm up at a standstill for approx. 10 minutes.

**⚠ Caution:**

The engine must not run for more than 20 minutes when the motorcycle is not moving.

**Oil temperature:**.....at least 90 °C  
(FID: at least 5 bars)

- Switch on the Synchrotester and select the bar chart display with maximum resolution..

**📄 Note:**

If the differences between the individual col-umns are very large (greater than 5 mm), switch to graph display and compare the cylinders; carry out fault diagnosis if necessary.

➡ See BMW Synchrotester diagnosis instructions.

- Rectify any faults found.

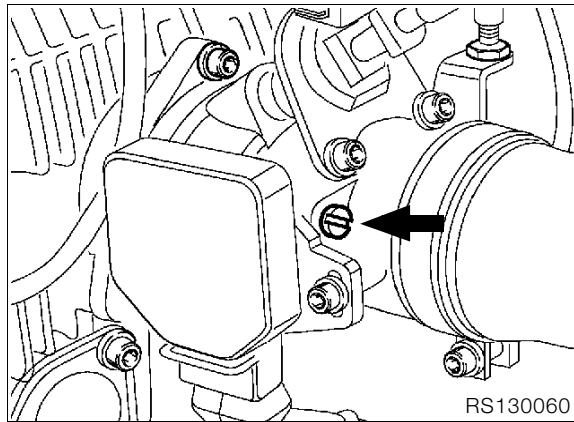

- Set idle speed using recirculating air screws while maintaining synchronous running.



**Note:**

Make sure that both throttle valves are closed.

**Idle speed:**..... 1000 + 150 min<sup>-1</sup>

**⚠ Caution:**

The sealed stop screws on the throttles must not be tampered with, or else the basic idle flow setting will have to be reset by the manufacturer.

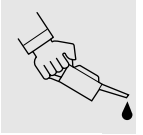

### With cable junction block

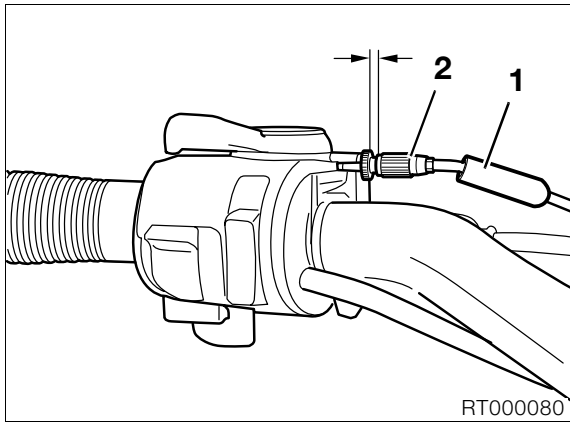

- Push back the protective rubber cap (1) at the throttle and choke cables.
- Turn adjusting screw (2) at the throttle and choke cables to adjust play.

**Choke cable play:** ..... app. 1 mm (0.039 in)

**Throttle cable play:** ..... app. 1 mm (0.039 in)

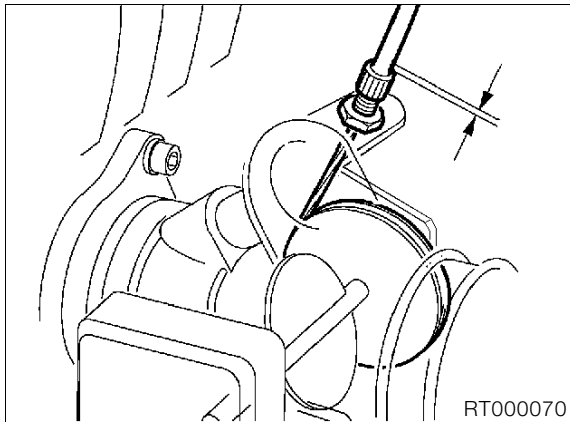

- Turn adjusting screws at the left and right throttles to adjust play.

**Throttle cable play:** ..... app. 2 mm (0.0787 in)

- Connect the BMW Synchrotester, **BMW No. 13 0 800**, to the vacuum bores of the throttles..
- Ride the motorcycle until the engine is warm, or alternatively allow it to warm up at a standstill for approx. 10 minutes.



#### **Caution:**

Engine must not run for more than 20 minutes when motorcycle is not moving.

**Oil temperature:** ..... at least 90 °C  
(FID: at least 5 bars)

- Switch on the Synchrotester and select the bar chart with maximum resolution.



#### **Note:**

If the differences between the individual columns are very large (greater than 5 mm), switch to graph display and compare the cylinders; carry out fault diagnosis if necessary.

➡ See BMW Synchrotester diagnosis instructions.



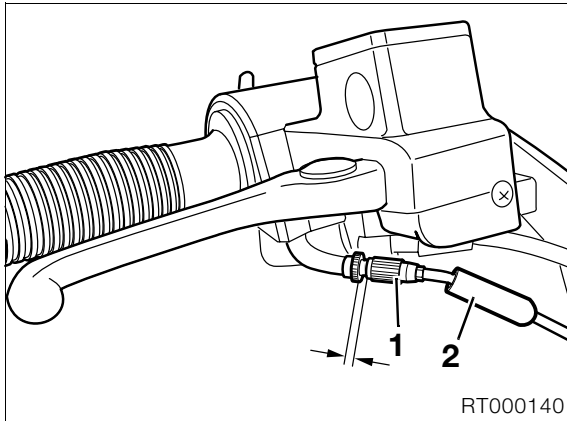

- Push the protective rubber cap (2) back over the adjusting screw.

**Throttle cable play:**..... app. 0.5 mm (0.0197 in)

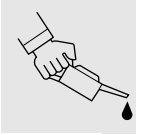
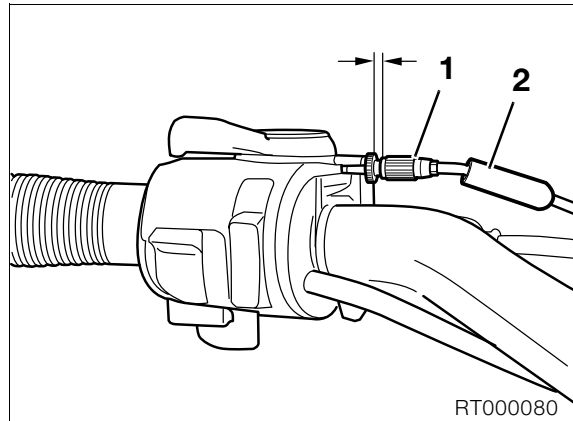

- Rectify any faults found.
- Set idle speed using recirculating air screws while maintaining synchronous running.

**Idle speed:** ..... 1000 + 150 min<sup>-1</sup>



**Note:**

Make sure that both throttle valves are closed.



**Caution:**

The sealed stop screws on the throttles must not be tampered with, or else the basic idle flow setting will have to be reset by the manufacturer.

- Adjust choke cable to zero play at screw (1).
- Push the protective rubber cap (2) over the adjusting screw.
- Check the setting by turning the handlebar between the full right and left lock positions. Engine speed must not change during this check.

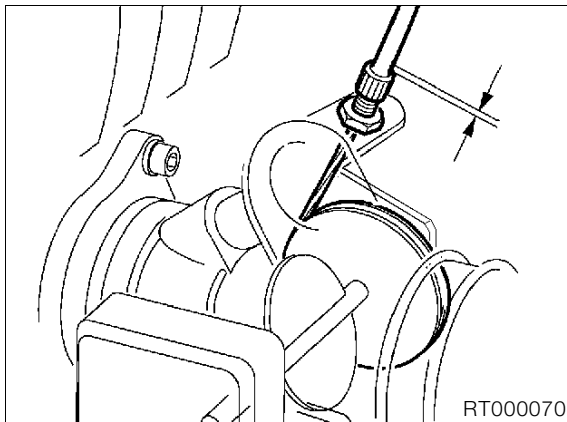

- Carefully reduce play at the left throttle until the bar display on the Syncrotester changes.
- Turn the adjusting screw until the bar display reverts to its original height.
- Tighten the locknut.



**Note:**

The height of the bar display must not change when the locknut is tightened.

- Repeat this procedure at the right throttle



**Note:**

If play is zero, the throttle butterflies may chatter.

- Adjust throttle cable play at screws (1).

## Final inspection with road safety and functional check

(Inspection I, II, III, IV)

### Road safety check

- Check wheels and tyres.
- Check/correct tyre pressures.

### Tyre pressures:

Rider only.....	front 2.2 bar(31.9 psi)
.....	rear 2.5 bar (36.26 psi)
With pillion passenger .....	front 2.5 bar(36.26 psi)
.....	rear 2.7 bar(39.16 psi)
With pillion passenger + luggage.....	.....
.....	front 2.5 bar(36.26 psi)
.....	rear 2.9 bar(42.06 psi)

### Roadworthiness check

- Lights
- Telltale/warning lights
- Horn
- Instruments
- Special equipment
- Clutch
- Gear shift
- Steering
- Foot brake and handbrake
- If necessary, take motorcycle for a trial run.

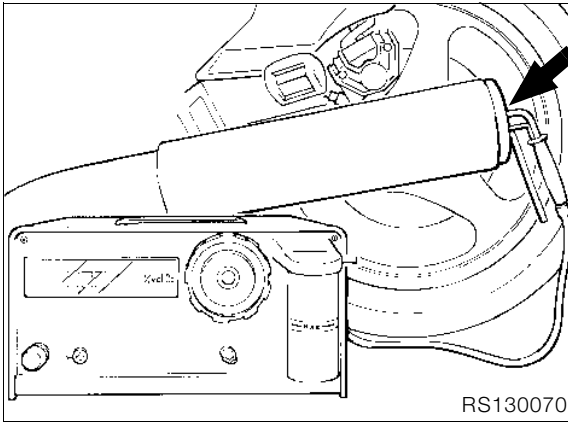

RS130070

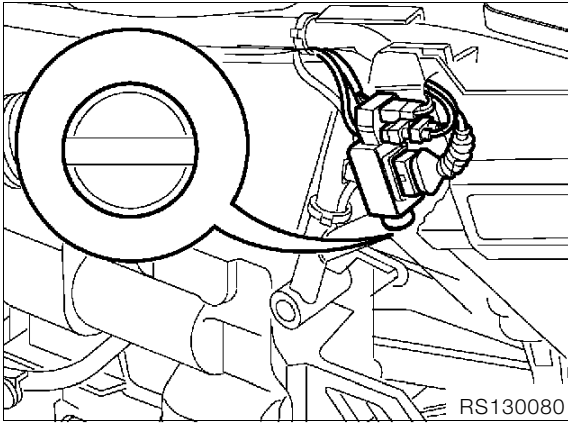

RS130080

- On motorcycles **without catalytic converter** make sure that the idle-speed CO content of the exhaust gas is in accordance with the nominal value and correct at the idle potentiometer if necessary.

**Idle-speed CO content:**.....  $1.5 \pm 0.5$  (% by vol.)

- Check synchronisation of throttles by opening them repeatedly but slowly up to an engine speed of app. 2500 rpm; the vacuum columns on the Synchrotester must drop together. Correct if necessary by turning the adjusting screws for the connecting cable.  
When doing this, ensure that both throttles return to the limit position when closed.



#### Note:

Make sure that both throttle valves close against their stops when the throttle twistgrip is released.

- Tighten locknuts and check synchronous running again.
- Seal the vacuum bores.

# 11 Motor

## Contents

Page

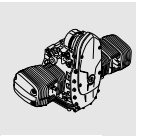

<b>Technical Data</b> .....	5
<b>Sectioned drawing of engine</b> .....	37
<b>Lubricating oil circuit</b> .....	38
<b>Coolant circuit</b> .....	39
<b>Cooling oil circuit (with oil thermostat)</b> .....	40
<b>Removing engine</b> .....	41
Fitting auxiliary frame .....	52
Take off auxiliary frame. ....	53
<b>Dismantling engine</b> .....	54
Removing cylinder head cover .....	55
Locking the engine in the TDC position .....	56
TDC on ignition stroke: .....	56
Removing and installing chain tensioner .....	57
Assembly specification for timing chain tensioner: .....	57
Removing valve gear holder .....	58
Dismantling/reassembling valve gear holder .....	59
Removing cylinder head .....	61
Dismantling, checking, repairing and re-assembling cylinder head .....	62
Removing and installing valves .....	62
Removing valve stem seals .....	62
Checking valves for wear .....	63
Remachining valve seat .....	63
Checking and repairing cylinder head .....	63
Checking valve guide for wear .....	63
Replacing valve guides .....	64
Installing valve and valve stem seal .....	65
Removing cylinder barrel .....	66
Removing/dismantling piston .....	66
Checking pistons and cylinders .....	67
Assemble pistons .....	67

# Contents

Page

Removing/installing conrod .....	68
Removing and installing alternator cover with engine installed .....	69
Removing alternator mount cover .....	69
Renewing radial shaft seal in alternator mount cover .....	70
Renewing radial shaft seal for rotary breather .....	70
Removing auxiliary-shaft drive .....	71
Removing oil pump .....	72
Oil temperature regulator .....	72
Removing radial shaft seal on crank-shaft with engine installed .....	73
Dismantling crankcase .....	74
Removing crankshaft, auxiliary shaft and timing chain tensioning and slide rails .....	76
Removing and installing oil pick-up basket .....	77
Replacing oil level sight glass .....	77
Removing conrods .....	77
Checking conrods .....	77
Measuring main and big end bearing play .....	78
Measuring radial bearing play .....	78
Install main bearings .....	79
Measuring axial bearing play .....	79
Measuring big end bearing play .....	80
<b>Assembling engine</b> .....	81
Installing conrod .....	81
Installing crankshaft .....	82
Installing timing chain tensioning and slide rails .....	82
Installing auxiliary shaft/timing chains .....	82
Assembling engine block .....	83
Installing radial seal on crankshaft .....	85
Installing clutch housing .....	86
Installing oil pump .....	87

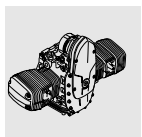

# Contents

Page

Installing auxiliary shaft drive .....	88
Installing pistons .....	89
Installing cylinders .....	90
Installing cylinder head .....	91
Adjusting valve clearances .....	92
Installing right cylinder head .....	93
Adjustment specification .....	93
Installing left cylinder head .....	94
Adjustment specification .....	94
Installing alternator mount cover .....	96
Installing magnetic gate/belt pulley .....	96
Timing the ignition .....	97
Installing alternator .....	98
<b>Installing engine</b> .....	<b>99</b>

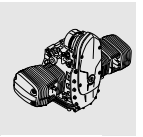

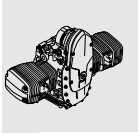

Technical Data		R 1100 RS
<b>Engine, general</b>		
Engine design	Four-stroke flat twin, air-cooled with oil-cooled exhaust ports, installed longitudinally, 4 valves per cylinder, two high-mounted camshafts, electronic fuel injection.	
Location of engine number	Crankcase	
Cylinder bore	mm (in)	99.0 (3.898)
Stroke	mm (in)	70.5 (2.776)
Effective displacement	cc	1085
Compression ratio		10.7 : 1
Power output	kW(bhp)/min <sup>-1</sup>	66(90)/7250
Max. torque	Nm/min <sup>-1</sup>	95/5500
Permissible maximum engine speed	min <sup>-1</sup>	7900
Permissible continuous engine speed	min <sup>-1</sup>	7600
Idle speed	min <sup>-1</sup>	1000 +150
Direction of rotation		Clockwise, looking at ignition system
Compression test pressure		
good	bar (psi)	above 10 (145.04)
normal	bar (psi)	8.5...10 (123.28...145.04)
poor	bar (psi)	below 8.5(123.28)
Intake port dia./cylinder head	mm (in)	44 (1.732)
<b>Lubrication system</b>		
Theoretical volume in circulation at 6000 min <sup>-1</sup>		
Lubricating oil	l (Imp. pints)	36 (63.36)
Cooling oil	l (Imp. pints)	30 (52.8)
Oil filter		Full-flow type
Pressure differential needed to open bypass valve	bar (psi)	1.5 (21.756)
Oil pressure warning light comes on below	bar (psi)	0.2...0.5 (2.9...7.25)
Pressure relief valve opens at	bar (psi)	5.5 (79.77)
Operating pressure	bar (psi)	3.5...6.0 (50.76...87.02)
Oil content		
without filter change	l (Imp. pints)	3.50 (6.16)
with filter change	l (Imp. pints)	3.75 (6.6)
min/max	l (Imp. pints)	0.50 (0.88)
Permissible oil consumption	l/1000 km Imp.pint/miles	1.0 (1.41/500)
<b>Oil pump</b>		
Oil pump		2 Duocentric pumps
Housing depth	mm (in) mm (in)	12.02...12.05 (0.47322...0.47441) 10.02...10.05 (0.3945...0.3957)
Height of rotor	mm (in) mm (in)	11.95...11.98 (0.4705...0.4717) 9.95...9.98 (0.3917...0.3929)
Axial play	mm (in)	0.04...0.1 (0.0016...0.0039)
Wear limit	mm (in)	0.25 (0.0098)

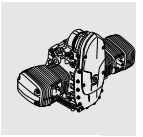

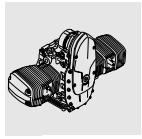

Technical Data		R 1100 RS
<b>Valves</b>		
Included angle between valves	°	41
Valve clearances, engine cold (max. 35 °C)		
Inlet valve	mm (in)	0.15 (0.0059)
Exhaust valve	mm (in)	0.30 (0.0118)
Valve timing		Zero valve clearance. 3 mm (0.1181 in) valve lift
Inlet opens		5° after TDC
Inlet closes		33° after BDC
Exhaust opens		27° before BDC
Exhaust closes		5° before TDC
		Tolerance ± 3°
Valve head dia.		
Inlet	mm (in)	36 (1.4173)
Exhaust	mm (in)	31(1.2205)
		from 1996 mod. year on
Inlet	mm (in)	34 (1.3386)
Exhaust	mm (in)	29 (1.1417)
Stem dia.		
Inlet	mm (in)	5.960...5.975 (0.23465...0.23524)
Wear limit	mm (in)	5.940 (0.23386)
Exhaust	mm (in)	5.945...5.960 (0.23406...0.23465)
Wear limit	mm (in)	5.925 (0.23327)
		from 1996 mod. year on
Inlet	mm (in)	4.966...4.980 (0.16551...0.19606)
Wear limit	mm (in)	4.946 (0.19472)
Exhaust	mm (in)	4.956..4.970 (0.19512...0.19567)
Wear limit	mm (in)	4.936 (0.19433)
Valve head edge thickness		
Inlet	mm (in)	1.00 ± 0.2 (0.03937 ± 0.00787)
Wear limit	mm (in)	0.5 (0.01969)
Exhaust	mm (in)	1.65 ± 0.2 (0.06496 ± 0.00787)
Wear limit	mm (in)	1.0 (0.03937)
		from 1996 mod. year on
Inlet	mm (in)	1.00 ± 0.2 (0.03937 ± 0.00787)
Wear limit	mm (in)	0.5 (0.01969)
Exhaust	mm (in)	1.00 ± 0.2 (0.03937 ± 0.00787)
Wear limit	mm (in)	0.5 (0.01969)
Max. runout of valve head at valve seat		
Inlet, exhaust	mm (in)	0.035 (0.001378)



Technical Data		R 1100 RS
<b>Valve seat ring</b>		
Valve seat angle		
Inlet		45°
Exhaust		30°
		from 1996 mod. year on
Inlet		45°
Exhaust		45°
Valve seat width		
Inlet	mm (in)	1.1 ± 0.15 (0.04331 ± 0.00591)
Wear limit	mm (in)	2.5 (0.09843)
Exhaust	mm (in)	1.4 ± 0.15 (0.05512 ± 0.00591)
Wear limit	mm (in)	3.0 (0.11811)
Valve seat extl. dia. (dimension for valve seat machining)		
Inlet	mm (in)	35.2 ± 0.1 (1.38583 ± 0.003937)
Exhaust	mm (in)	30.3 ± 0.1 (1.19291 ± 0.00393)
		from 1996 mod. year on
Inlet	mm (in)	33.4 ± 0.1 (1.31496 ± 0.00393)
Exhaust	mm (in)	28.4 ± 0.1 (1.11811 ± 0.00393)
Seat ring dia. (oversize +0.2 mm)		
Inlet	mm (in)	37.634...37.650 (1.48165...1.48228)
Exhaust	mm (in)	34.134...34.150 (1.34386...1.34449)
		from 1996 mod. year on
Inlet	mm (in)	36.617...36.633 (1.44161...1.44224)
Exhaust	mm (in)	32.134...32.150 (1.26512...1.26575)
Seat dia. in cylinder head (oversize +0.2 mm)		
Inlet	mm (in)	37.500...37.525 (1.47638...1.47736)
Exhaust	mm (in)	34.000...34.025 (1.33859...1.33957)
		from 1996 mod. year on
Inlet	mm (in)	36.500...36.525 (1.43701...1.43799)
Exhaust	mm (in)	32.000...32.025 (1.25984...1.26083)

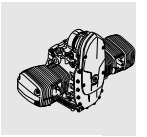

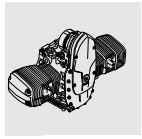

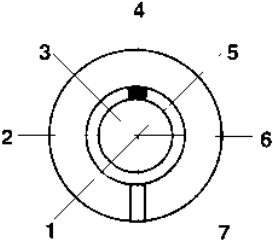

Technical Data			R 1100 RS
<b>Valve guide</b>			
Valve guide	Extl. dia.	mm (in)	12.533...12.544 (0.49343...0.49386)
Bore in cylinder head		mm (in)	12.500...12.518 (0.49213...0.49283)
Overlap		mm (in)	0.015...0.044 (0.00059...0.001732)
<b>Repair stages</b>			
Replacement valve guide	Extl. dia.	mm (in)	12.550...12.561 (0.49409...0.49453)
Oversize valve guide	Extl. dia.	mm (in)	12.733...12.744 (0.501299...0.501732)
Valve guide	Intl. dia.	mm (in)	6.0...6.015 (0.23622...0.23681)
Radial clearance	Inlet	mm (in)	0.025...0.055 (0.000984...0.002165)
		Wear limit	mm (in)
	Exhaust	mm (in)	0.040...0.070 (0.001575...0.002756)
		Wear limit	mm (in)
Valve guide	Intl. dia.	mm (in)	from 1996 mod. year on 5.0...5.012 (0.19685...0.19732)
Radial clearance	Inlet	mm (in)	0.020...0.046 (0.000787...0.001811)
		Wear limit	mm (in)
	Exhaust	mm (in)	0.030...0.056 (0.0011811...0.002205)
		Wear limit	mm (in)
<b>Valve spring</b>			
Spring length,	off-load	mm (in)	41.1 (1.61811)
	Wear limit	mm (in)	39.0 (1.53543)
<b>Rocker</b>			
Bore dia.		mm (in)	16.016...16.027 (0.63055...0.63984)
Rocker shaft dia.		mm (in)	15.973...15.984 (0.62886...0.62929)
Radial clearance		mm (in)	0.032...0.054 (0.001259...0.002126)
	Wear limit	mm (in)	0.1 (0.003937)
Axial play	min.	mm (in)	0.05 (0.001969)
	max.	mm (in)	0.40 (0.01575)

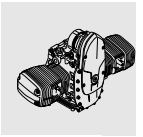
Technical Data		R 1100 RS
<b>Camshaft</b>		
Opening angle, inlet/exhaust cams Cam spread, inlet/exhaust Marking		300° 106°/109°  Marking in position <b>4</b>
		
Inlet valve lift	mm (in)	9.68 (0.3811) (valve clearance = 0)
Exhaust valve lift	mm (in)	9.26 (0.36457) (valve clearance = 0)
Camshaft bearing bore dia.	mm (in)	21.02...21.04 (0.82756...0.828346)
Camshaft dia.	mm (in)	20.97...21.00 (0.82559...0.82677)
Radial clearance	mm (in)	0.02...0.07 (0.000787...0.0027559)
Wear limit	mm (in)	0.15 (0.0059055)
Width of guide bearing	mm (in)	15.92...15.95 (0.62677...0.62795)
Width of camshaft bearing	mm (in)	16.0...16.05 (0.62992...0.6318897)
Axial play	mm (in)	0.08...0.13 (0.0031496...0.005118)
Wear limit	mm (in)	0.25 (0.0098425)
<b>Bucket-type tappet</b>		
Extl. dia.	mm (in)	23.947...23.960 (0.942795...0.9433)
Bore dia. in cylinder head	mm (in)	24.000...24.021 (0.94488...0.94571)
Radial clearance	mm (in)	0.040...0.074 (0.00175...0.002913)
Wear limit	mm (in)	0.18 (0.0070866)
<b>Auxiliary shaft</b>		
Bore dia. in crankcase front/back	mm (in)	25.020...25.041 (0.98504...0.985866)
Auxiliary shaft dia. front/back	mm (in)	24.959...24.980 (0.98264...0.98346)
Radial clearance	mm (in)	0.040...0.082 (0.001575...0.003228)
Wear limit	mm (in)	0.17 (0.006693)

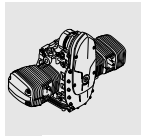



Technical Data		R 1100 RS
<b>Crankshaft</b>		
Marking of main bearing and crankpin on front crank web no paint mark paint mark		Grinding stage 0 Grinding stage 1 -0.25mm (-0.009843 in)
Grinding stage 0 (grinding stage 1= -0.25mm)		
Guide bearing bore dia. mm (in)		64.949...64.969 (2.557047...2.557834)
Guide bearing dia. mm (in)		Green: 59.964...60.003 (2.36079...2.36232) Yellow: 59.974...60.013 (2.36118...2.36272)
Main bearing journal dia. mm (in)		Green: 59.939...59.948 (2.35980...2.360157) Yellow: 59.949...59.958 (2.360197...2.36055)
Radial clearance mm (in)		0.016...0.064 (0.0006299..0.002519)
Wear limit mm (in)		0.1 (0.003937)
Main bearing bore dia. mm (in)		60.000...60.019 (2.3622...2.36295)
Main bearing dia. mm (in)		Green: 54.998...55.039 (2.16528...2.16689) Yellow: 55.008...55.049 (2.16567...2.16728)
Main bearing journal dia. mm (in)		Green: 54.971...54.980 (2.1642...2.164567) Yellow: 54.981...54.990 (2.16461...2.16496)
Radial clearance mm (in)		0.018...0.068 (0.0001086...0.002677)
Wear limit mm (in)		0.13 (0.005118)
Width of guide bearing mm (in)		24.890...24.940 (0.97992...0.98189)
Bearing width of main bearing journal mm (in)		25.020...25.053 (0.98504...0.986339)
Axial play mm (in)		0.080...0.163 (0.0031496...0.006417)
Wear limit mm (in)		0.2 (0.007874)
Grinding stage 0 (grinding stage 1= -0.25mm)		
Crankpin dia. mm (in)		47.975...47.991 (1.88878...1.88941)
Bearing width of crankpin mm (in)		22.065...22.195 (0.86870...0.87381)
<b>Connecting rod</b>		
Big end bore dia. mm (in)		51.000...51.013 (2.00787...2.008386)
Big end bearing dia. mm (in)		48.016...48.050 (1.89039...1.89173)
Radial clearance mm (in)		0.025...0.075 (0.000984...0.0029527)
Wear limit mm (in)		0.13 (0.001118)

Technical Data			R 1100 RS
Width of big end bearing eye	mm (in)		21.883...21.935 (0.86154...0.86358)
Conrod end float	mm (in)		0.130...0.312 (0.005118...0.0122834)
Wear limit	mm (in)		0.5 (0.019685)
Small end bearing bore dia.	mm (in)		22.015...22.025 (0.86673...0.867126)
Radial clearance	mm (in)		0.015...0.030 (0.0005905...0.0018)
Wear limit	mm (in)		0.06 (0.0023622)
Distance between centers	mm (in)		125 (4.92126)
Max. deviation from parallel of conrod bores at 150 mm spacing	mm (in)		0.07 (0.0027559)
<b>Cylinders</b>			
Bore			20 mm (0.7874 in) from top edge
A	mm (in)		98.992...99.000 (3.89732...3.897638)
Wear limit	mm (in)		99.050 (3.899606)
B	mm (in)		99.000...99.008 (3.897638...3.897953)
Wear limit	mm (in)		99.058 (3.899921)
Total wear clearance of piston and cylinder	mm (in)		0.12 (0.0047244)
Permitted out-of-roundness of cylinder bore			
20 mm from the top edge	mm (in)		0.03 (0.0011811)
100 mm from the lower edge	mm (in)		0.04 (0.0015748)
<b>Pistons</b>			
Piston dia.		Measuring plane A –  see Checking pistons and cylinders	
A	mm (in)		98.965...98.977 (3.89626...3.896732)
Wear limit	mm (in)		98.890 (3.8933)
B	mm (in)		98.977...98.989 (3.896732...3.897204)
Wear limit	mm (in)		98.900 (3.8937)
AB	mm (in)		98.973...98.981 (3.89657...3.8968897)
Wear limit	mm (in)		98.895 (3.8935039)
Installed clearance	mm (in)		0.011...0.035 (0.000433...0.0013779)
Total wear clearance of piston and cylinder	mm (in)		0.12 (0.0047244)
Piston pin bore dia.	mm (in)		22.005...22.011 (0.86634...0.866575)
Weight classes			+ and -
Weight difference in one class	g (oz.)		10 (0.35) (complete with pins and rings)
Direction of installation			Arrow on piston crown pointing to exhaust side
			Production location towards exhaust side  (see Installing Piston)

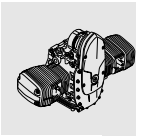

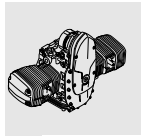

Technical Data		R 1100 RS
<b>Piston rings</b>		
1st groove Micro-taper compression ring		
Height	mm (in)	1.175...1.190 (0.04626...0.04685)
Wear limit	mm (in)	1.1 (0.043307)
Gap clearance	mm (in)	0.1...0.3 (0.003937...0.0118)
Wear limit	mm (in)	0.8 (0.031496)
Side clearance	mm (in)	0.040...0.075 (0.001575...0.002953)
Wear limit	mm (in)	0.15 (0.00591)
2nd groove Micro-taper compression ring		
Height	mm (in)	1.175...1.190 (0.04626...0.04685)
Wear limit	mm (in)	1.1 (0.043307)
Gap clearance	mm (in)	0.1...0.3 (0.003937...0.0118)
Wear limit	mm (in)	0.8 (0.031496)
Side clearance	mm (in)	0.030...0.065 (0.00118...0.002559)
Wear limit	mm (in)	0.15 (0.00591)
3rd groove Equal-chamfer ring + tubular spring		
Height	mm (in)	2.475...2.490 (0.09744...0.09803)
Wear limit	mm (in)	2.4 (0.094488)
Gap clearance	mm (in)	0.30...0.60 (0.011811...0.023622)
Wear limit	mm (in)	1.20 (0.047244)
Side clearance	mm (in)	0.020...0.055 (0.000787...0.002165)
Wear limit	mm (in)	0.15 (0.00591)
Installed direction of piston rings		"Top" marking uppermost
<b>Piston pin</b>		
Piston pin dia.	mm (in)	21.995...22.000 (0.86594...0.86614)
Wear limit	mm (in)	21.960 (0.864567)
Bore dia. in piston	mm (in)	22.005...22.011 (0.866339...0.8665748)
Radial clearance in piston	mm (in)	0.005...0.016 (0.000197...0.0006299)
Wear limit	mm (in)	0.070 (0.0027559)

Technical Data		R 1100 RT
<b>Engine, general</b>		
Engine design	Four-stroke flat twin, air-cooled with oil-cooled exhaust ports, installed longitudinally, 4 valves per cylinder, two high-mounted camshafts, electronic fuel injection.	
Location of engine number	Crankcase	
Cylinder bore	mm (in)	99.0 (3.898)
Stroke	mm (in)	70.5 (2.776)
Effective displacement	cc	1085
Compression ratio		10.7 : 1
Power output	kW(bhp)/min <sup>-1</sup>	66(90)/7250
Max. torque	Nm/min <sup>-1</sup>	95/5500
Permissible maximum engine speed	min <sup>-1</sup>	7900
Permissible continuous engine speed	min <sup>-1</sup>	7600
Idle speed	min <sup>-1</sup>	1000 +150
Direction of rotation		Clockwise, looking at ignition system
Compression test pressure		
good	bar (psi)	above 10 (145.04)
normal	bar (psi)	8.5..10(123.28..145.04)
poor	bar (psi)	below 8.5(123.28)
Intake port dia./cylinder head	mm (in)	44 (1.732)
<b>Lubrication system</b>		
Theoretical vol. in circulation at 6000 min <sup>-1</sup>		
Lubricating oil	l (Imp. pints)	36 (63.36)
Cooling oil	l (Imp. pints)	30 (52.8)
Oil filter		Full-flow type
Pressure differential needed to open bypass valve	bar (psi)	1.5 (21.756)
Oil pressure warning light comes on below	bar (psi)	0.2...0.5 (2.9...7.25)
Pressure relief valve opens at	bar (psi)	5.5 (79.77)
Operating pressure	bar (psi)	3.5...6.0 (50.76...87.02)
Oil content		
without filter change	l (Imp. pints)	3.50 (6.16)
with filter change	l (Imp. pints)	3.75 (6.6)
min/max	l (Imp. pints)	0.50 (0.88)
Permissible oil consumption	l/1000 km Imp.pint/miles	1.0 (1.41/500)
<b>Oil pump</b>		
Oil pump		2 Duocentric pumps
Housing depth	mm (in) mm (in)	12.02...12.05 (0.47322...0.47441) 10.02...10.05 (0.3945...0.3957)
Height of rotor	mm (in) mm (in)	11.95...11.98 (0.4705...0.4717) 9.95...9.98 (0.3917...0.3929)
Axial play	mm (in)	0.04...0.1 (0.0016...0.0039)
Wear limit	mm (in)	0.25 (0.0098)

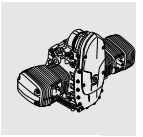

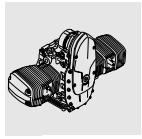

Technical Data		R 1100 RT
<b>Valves</b>		
Included angle between valves	°	41
Valve clearance with engine cold (max. 35 °C)		
Inlet valve	mm (in)	0.15 (0.0059)
Exhaust valve	mm (in)	0.30 (0.0118)
Valve timing		At zero valve clearance and 3 mm (0.1181 in) valve lif
Inlet opens		5° after TDC
Inlet closes		33° after BDC
Exhaust opens		27° before BDC
Exhaust closes		5° before TDC
		Tolerance ± 3°
Valve head dia.		
Inlet	mm (in)	36 (1.4173)
Exhaust	mm (in)	31(1.2205)
		from 1996 mod. year on
Inlet	mm (in)	34 (1.3386)
Exhaust	mm (in)	29 (1.1417)
Stem dia.		
Inlet	mm (in)	5.960...5.975 (0.23465...0.23524)
Wear limit	mm (in)	5.940 (0.23386)
Exhaust	mm (in)	5.945...5.960 (0.23406...0.23465)
Wear limit	mm (in)	5.925 (0.23327)
		from 1996 mod. year on
Inlet	mm (in)	4.966...4.980 (0.16551...0.19606)
Wear limit	mm (in)	4.946 (0.19472)
Exhaust	mm (in)	4.956..4.970 (0.19512...0.19567)
Wear limit	mm (in)	4.936 (0.19433)
Valve head edge thickness		
Inlet	mm (in)	1.00 ± 0.2 (0.03937 ± 0.00787)
Wear limit	mm (in)	0.5 (0.01969)
Exhaust	mm (in)	1.65 ± 0.2 (0.06496 ± 0.00787)
Wear limit	mm (in)	1.0 (0.03937)
		from 1996 mod. year on
Inlet	mm (in)	1.00 ± 0.2 (0.03937 ± 0.00787)
Wear limit	mm (in)	0.5 (0.01969)
Exhaust	mm (in)	1.00 ± 0.2 (0.03937 ± 0.00787)
Wear limit	mm (in)	0.5 (0.01969)
Max. runout of valve head at valve seat		
Inlet, exhaust	mm (in)	0.035 (0.001378)



Technical Data		R 1100 RT
Seat dia. in cylinder head (oversize +0.2 mm)		
Inlet	mm (in)	37.500...37.525 (1.47638...1.47736)
Exhaust	mm (in)	34.000...34.025 (1.33859...1.33957)
from 1996 mod. year on		
Inlet	mm (in)	36.500...36.525 (1.43701...1.43799)
Exhaust	mm (in)	32.000...32.025 (1.25984...1.26083)
<b>Valve seat ring</b>		
Valve seat angle		
Inlet		45°
Exhaust		30°
from 1996 mod. year on		
Inlet		45°
Exhaust		45°
Valve seat width		
Inlet	mm (in)	1.1 ± 0.15 (0.04331 ± 0.00591)
Wear limit	mm (in)	2.5 (0.09843)
Exhaust	mm (in)	1.4 ± 0.15 (0.05512 ± 0.00591)
Wear limit	mm (in)	3.0 (0.11811)
Valve seat extl. dia. (dimension for valve seat machining)		
Inlet	mm (in)	35.2 ± 0.1 (1.38583 ± 0.003937)
Exhaust	mm (in)	30.3 ± 0.1 (1.19291 ± 0.00393)
from 1996 mod. year on		
Inlet	mm (in)	33.4 ± 0.1 (1.31496 ± 0.00393)
Exhaust	mm (in)	28.4 ± 0.1 (1.11811 ± 0.00393)
Seat ring dia. (oversize +0.2 mm)		
Inlet	mm (in)	37.634...37.650 (1.48165...1.48228)
Exhaust	mm (in)	34.134...34.150 (1.34386...1.34449)
from 1996 mod. year on		
Inlet	mm (in)	36.617...36.633 (1.44161...1.44224)
Exhaust	mm (in)	32.134...32.150 (1.26512...1.26575)

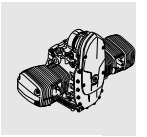

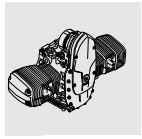

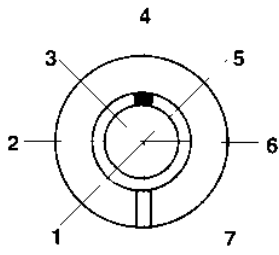

Technical Data			R 1100 RT
<b>Valve guide</b>			
Valve guide	Extl. dia.	mm (in)	12.533...12.544 (0.49343...0.49386)
Bore in cylinder head		mm (in)	12.500...12.518 (0.49213...0.49283)
Overlap		mm (in)	0.015...0.044 (0.00059...0.001732)
<b>Repair stages</b>			
Replacement valve guide	Extl. dia.	mm (in)	12.550...12.561 (0.49409...0.49453)
Oversize valve guide	Extl. dia.	mm (in)	12.733...12.744 (0.501299...0.501732)
Valve guide	Intl. dia.	mm (in)	6.0...6.015 (0.23622...0.23681)
Radial clearance	Inlet	mm (in)	0.025...0.055 (0.000984...0.002165)
		Wear limit	mm (in)
	Exhaust	mm (in)	0.040...0.070 (0.001575...0.002756)
		Wear limit	mm (in)
Valve guide	Intl. dia.	mm (in)	from 1996 mod. year on 5.0...5.012 (0.19685...0.19732)
Radial clearance	Inlet	mm (in)	0.020...0.046 (0.000787...0.001811)
		Wear limit	mm (in)
	Exhaust	mm (in)	0.030...0.056 (0.0011811...0.002205)
		Wear limit	mm (in)
<b>Valve spring</b>			
Spring length,	off-load	mm (in)	41.1 (1.61811)
	Wear limit	mm (in)	39.0 (1.53543)
<b>Rocker</b>			
Bore dia.		mm (in)	16.016...16.027 (0.63055...0.63984)
Rocker shaft dia.		mm (in)	15.973...15.984 (0.62886...0.62929)
Radial clearance		mm (in)	0.032...0.054 (0.001259...0.002126)
	Wear limit	mm (in)	0.1 (0.003937)
Axial play	min.	mm (in)	0.05 (0.001969)
	max.	mm (in)	0.40 (0.01575)

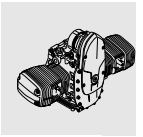
Technical Data		R 1100 RT
<b>Camshaft</b>		
Opening angle, inlet/exhaust cams Cam spread, inlet/exhaust Marking		300° 106°/109°  Marking in position <b>4</b>
		
Inlet valve lift	mm (in)	9.68 (0.3811) (valve clearance = 0)
Exhaust valve lift	mm (in)	9.26 (0.36457) (valve clearance = 0)
Camshaft bearing bore dia.	mm (in)	21.02...21.04 (0.82756...0.828346)
Camshaft dia.	mm (in)	20.97...21.00 (0.82559...0.82677)
Radial clearance	mm (in)	0.02...0.07 (0.000787...0.0027559)
Wear limit	mm (in)	0.15 (0.0059055)
Width of guide bearing	mm (in)	15.92...15.95 (0.62677...0.62795)
Width of camshaft bearing	mm (in)	16.0...16.05 (0.62992...0.6318897)
Axial play	mm (in)	0.08...0.13 (0.0031496...0.005118)
Wear limit	mm (in)	0.25 (0.0098425)
<b>Bucket-type tappet</b>		
Extl. dia.	mm (in)	23.947...23.960
Bore dia. in cylinder head	mm (in)	24.000...24.021 (0.94488...0.94571)
Radial clearance	mm (in)	0.040...0.074 (0.00175...0.002913)
Wear limit	mm (in)	0.18 (0.0070866)
<b>Auxiliary shaft</b>		
Bore dia. in crankcase front/back	mm (in)	25.020...25.041 (0.98504...0.985866)
Auxiliary shaft dia. front/back	mm (in)	24.959...24.980 (0.98264...0.98346)
Radial clearance	mm (in)	0.040...0.082 (0.001575...0.003228)
Wear limit	mm (in)	0.17 (0.006693)

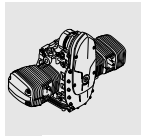



Technical Data		R 1100 RT
<b>Crankshaft</b>		
Marking of main bearing and crankpin on front crank web no paint mark paint mark		Grinding stage 0 Grinding stage 1 (-0.25mm (-0.009843))
Grinding stage 0 (grinding stg. 1=-0.25mm)		
Guide bearing bore dia. mm (in)		64.949...64.969 (2.557047...2.557834)
Guide bearing dia. mm (in)		Green: 59.964...60.003 (2.36079...2.36232) Yellow: 59.974...60.013 (2.36118...2.36272)
Main bearing journal dia. mm (in)		Green: 59.939...59.948 (2.35980...2.360157) Yellow: 59.949...59.958 (2.360197...2.36055)
Radial clearance mm (in)		0.016...0.064 (0.0006299..0.002519)
Wear limit mm (in)		0.1 (0.003937)
Main bearing bore dia. mm (in)		60.000...60.019 (2.3622...2.36295)
Main bearing dia. mm (in)		Green: 54.998...55.039 (2.16528...2.16689) Yellow: 55.008...55.049 (2.16567...2.16728)
Main bearing journal dia. mm (in)		Green: 54.971...54.980 (2.1642...2.164567) Yellow: 54.981...54.990 (2.16461...2.16496)
Radial clearance mm (in)		0.018...0.068 (0.0001086...0.002677)
Wear limit mm (in)		0.13 (0.005118)
Width of guide bearing mm (in)		24.890...24.940 (0.97992...0.98189)
Bearing width of main bearing journal mm (in)		25.020...25.053 (0.98504...0.986339)
Axial play mm (in)		0.080...0.163 (0.0031496...0.006417)
Wear limit mm (in)		0.2 (0.007874)
Grinding stage 0 (grinding stg. 1 = -0.25mm)		
Crankpin dia. mm (in)		47.975...47.991 (1.88878...1.88941)
Bearing width of crankpin mm (in)		22.065...22.195 (0.86870...0.87381)

Technical Data			R 1100 RT
<b>Connecting rod</b>			
Big end bore dia.	mm (in)		51.000...51.013 (2.00787...2.008386)
Big end bearing dia.	mm (in)		48.016...48.050 (1.89039...1.89173)
Radial clearance	mm (in)		0.025...0.075 (0.000984...0.0029527)
Wear limit	mm (in)		0.13 (0.001118)
Width of big end bearing eye	mm (in)		21.883...21.935 (0.86154...0.86358)
Conrod end float	mm (in)		0.130...0.312 (0.005118...0.0122834)
Wear limit	mm (in)		0.5 (0.019685)
Small end bearing bore dia.	mm (in)		22.015...22.025 (0.86673...0.867126)
Radial clearance	mm (in)		0.015...0.030 (0.0005905...0.0018)
Wear limit	mm (in)		0.06 (0.0023622)
Distance between centers	mm (in)		125 (4.92126)
Max. deviation from parallel of conrod bores at 150 mm spacing	mm (in)		0.07 (0.0027559)
<b>Cylinders</b>			
Bore			20mm (0.7874 in) from top edge
A	mm (in)		98.992...99.000 (3.89732...3.897638)
Wear limit	mm (in)		99.050 (3.899606)
B	mm (in)		99.000...99.008 (3.897638...3.897953)
Wear limit	mm (in)		99.058 (3.899921)
Total wear clearance of piston and cylinder	mm (in)		0.12 (0.0047244)
Permitted out-of-roundness of cylinder bore			
20 mm from the top edge	mm (in)		0.03 (0.0011811)
100 mm from the lower edge	mm (in)		0.04 (0.0015748)
<b>Pistons</b>			
Piston dia		Measuring plane A –  see Checking pistons and cylinders	
A	mm (in)		98.965...98.977 (3.89626...3.896732)
Wear limit	mm (in)		98.890 (3.8933)
B	mm (in)		98.977...98.989 (3.896732...3.897204)
Wear limit	mm (in)		98.900 (3.8937)
AB	mm (in)		98.973...98.981 (3.89657...3.8968897)
Wear limit	mm (in)		98.895 (3.8935039)
Installed clearance	mm (in)		0.011...0.035 (0.000433...0.0013779)
Total wear clearance of piston and cylinder	mm (in)		0.12 (0.0047244)

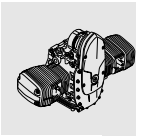

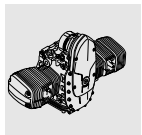

Technical Data		R 1100 RT
Piston pin bore dia.	mm (in)	22.005...22.011 (0.86634...0.866575)
Weight classes		+ and -
Weight difference in one class	g (oz.)	10 (0.35) (complete with pins and rings)
Direction of installation		Arrow on piston crown pointing to exhaust side
		Production locating towards exhaust side ➡ (see Installing piston)
<b>Piston rings</b>		
1st groove Micro-taper compression ring		
Height	mm (in)	1.175...1.190 (0.04626...0.04685)
Wear limit	mm (in)	1.1 (0.043307)
Gap clearance	mm (in)	0.1...0.3 (0.003937...0.0118)
Wear limit	mm (in)	0.8 (0.031496)
Side clearance	mm (in)	0.040...0.075 (0.001575...0.002953)
Wear limit	mm (in)	0.15 (0.00591)
2nd groove Micro-taper compression ring		
Height	mm (in)	1.175...1.190 (0.04626...0.04685)
Wear limit	mm (in)	1.1 (0.043307)
Gap clearance	mm (in)	0.1...0.3 (0.003937...0.0118)
Wear limit	mm (in)	0.8 (0.031496)
Side clearance	mm (in)	0.030...0.065 (0.00118...0.002559)
Wear limit	mm (in)	0.15 (0.00591)
3rd groove Equal-chamfer ring + tubular spring		
Height	mm (in)	2.475...2.490 (0.09744...0.09803)
Wear limit	mm (in)	2.4 (0.094488)
Gap clearance	mm (in)	0.30...0.60 (0.011811...0.023622)
Wear limit	mm (in)	1.20 (0.047244)
Side clearance	mm (in)	0.020...0.055 (0.000787...0.002165)
Wear limit	mm (in)	0.15 (0.00591)
Installed direction of piston rings		"Top" marking uppermost
<b>Piston pin</b>		
Piston pin dia.	mm (in)	21.995...22.000 (0.86594...0.86614)
Wear limit	mm (in)	21.960 (0.864567)
Bore dia. in piston	mm (in)	22.005...22.011 (0.866339...0.8665748)
Radial clearance in piston	mm (in)	0.005...0.016 (0.000197...0.0006299)
Wear limit	mm (in)	0.070 (0.0027559)

Technical Data	R 850 GS	R 1100 GS
<b>Engine, general</b>		
Engine design	Four-stroke flat twin, air-cooled with oil-cooled exhaust ports, installed longitudinally, 4 valves per cylinder, two high-mounted camshafts, electronic fuel injection.	
Location of engine number	Crankcase	
Cylinder bore	mm (in) 87.5 (3.445)	99.0 (3.898)
Stroke	mm (in) 70.5 (2.776)	70.5 (2.776)
Effective displacement	cc 848	1085
Compression ratio	10.3 : 1	10.3 : 1
Power output	kW(bhp)/min <sup>-1</sup> 52(70)/7000	59(80)/6750
Max. torque	Nm/min <sup>-1</sup> 77/5500	97/5250
Permissible maximum engine speed	min <sup>-1</sup> 8100	7800
Permissible continuous engine speed	min <sup>-1</sup> 7800	7600
Idle speed	min <sup>-1</sup> 1000 <sup>+150</sup>	1000 <sup>+150</sup>
Direction of rotation	Clockwise, looking at ignition system	Clockwise, looking at ignition system
Compression test pressure		
good	bar (psi) above 10 (145.04)	above 10 (145.04)
normal	bar (psi) 8.5...10 (123.28...145.04)	8.5...10 (123.28...145.04)
poor	bar (psi) below 8.5(123.28)	below 8.5(123.28)
Intake port dia./cylinder head	mm (in) 44 (1.732)	44 (1.732)
<b>Lubrication system</b>		
Theoretical vol. in circulation at 6000 min <sup>-1</sup>		
Lubricating oil	l (Imp. pints) 36 (63.36)	36 (63.36)
Cooling oil	l (Imp. pints) 30 (52.8)	30 (52.8)
Oil filter	Full-flow type	Full-flow type
Pressure differential needed to open bypass valve	bar (psi) 1.5 (21.756)	1.5 (21.756)
Oil pressure warning light comes on below	bar (psi) 0.2...0.5 (2.9...7.25)	0.2...0.5 (2.9...7.25)
Pressure relief valve opens at	bar (psi) 5.5 (79.77)	5.5 (79.77)
Operating pressure	bar (psi) 3.5...6.0 (50.76...87.02)	3.5...6.0 (50.76...87.02)
Oil content		
without filter change	l (Imp. pints) 3.50 (6.16)	3.50 (6.16)
with filter change	l (Imp. pints) 3.75 (6.6)	3.75 (6.6)
min/max	l (Imp. pints) 0.50 (0.88)	0.50 (0.88)
Permissible oil consumption	l/1000 km Imp.pint/miles 1.0 (1.41/500)	1.0 (1.41/500)
<b>Oil pump</b>		
Oil pump	2 Duocentric pumps	2 Duocentric pumps
Housing depth	mm (in) 12.02...12.05 mm (in) (0.47322...0.47441) 10.02...10.05 (0.3945...0.3957)	12.02...12.05 (0.47322...0.47441) 10.02...10.05 (0.3945...0.3957)
Height of rotor	mm (in) 11.95...11.98 mm (in) (0.4705...0.4717) 9.95...9.98 (0.3917...0.3929)	11.95...11.98 (0.4705...0.4717) 9.95...9.98 (0.3917...0.3929)
Axial play	mm (in) 0.04...0.1 (0.0016...0.0039)	0.04...0.1 (0.0016...0.0039)
Wear limit	mm (in) 0.25 (0.0098)	0.25 (0.0098)

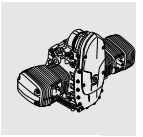

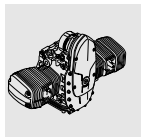

Technical Data		R 850 GS	R 1100 GS
<b>Valves</b>			
Included angle between valves	°	41	41
Valve clearance with engine cold (max. 35 °C)			
Inlet valve	mm (in)	0.15 (0.0059)	0.15 (0.0059)
Exhaust valve	mm (in)	0.30 (0.0118)	0.30 (0.0118)
Valve timing		At zero valve clearance and 3 mm (0.1181 in) valve li	
Inlet opens		1° before TDC	1° before TDC
Inlet closes		29° after BDC	29° after BDC
Exhaust opens		28° before BDC	28° before BDC
Exhaust closes		16° before TDC	16° before TDC
		Tolerance ± 3°	Tolerance ± 3°
Valve head dia.			
Inlet	mm (in)	32 (1.25984)	36 (1.4173)
Exhaust	mm (in)	27 (1.06299)	31(1.2205)
Inlet	mm (in)		from 1996 mod. year on 34 (1.3386)
Exhaust	mm (in)		29 (1.1417)
Stem dia.			
Inlet	mm (in)	4.966...4.980 (0.16551...0.19606)	5.960...5.975 (0.23465...0.23524)
Wear limit	mm (in)	4.946 (0.19472)	5.940 (0.23386)
Exhaust	mm (in)	4.956..4.970 (0.19512...0.19567)	5.945...5.960 (0.23406...0.23465)
Wear limit	mm (in)	4.936 (0.19433)	5.925 (0.23327)
Inlet	mm (in)		from 1996 mod. year on 4.966...4.980 (0.16551...0.19606)
Wear limit	mm (in)		4.946 (0.19472)
Exhaust	mm (in)		4.956..4.970 (0.19512...0.19567)
Wear limit	mm (in)		4.936 (0.19433)
Valve head edge thickness			
Inlet	mm (in)	1.00 ± 0.2 (0.03937 ± 0.00787)	1.00 ± 0.2 (0.03937 ± 0.00787)
Wear limit	mm (in)	0.5 (0.01969)	0.5 (0.01969)
Exhaust	mm (in)	1.00 ± 0.2 (0.03937 ± 0.00787)	1.65 ± 0.2 (0.06496 ± 0.00787)
Wear limit	mm (in)	0.5 (0.01969)	1.0 (0.03937)
Inlet	mm (in)		from 1996 mod. year on 1.00 ± 0.2 (0.03937 ± 0.00787)
Wear limit	mm (in)		0.5 (0.01969)
Exhaust	mm (in)		1.00 ± 0.2 (0.03937 ± 0.00787)
Wear limit	mm (in)		0.5 (0.01969)
Max. runout of valve head at valve seat			
Inlet, exhaust	mm (in)	0.035 (0.001378)	0.035 (0.001378)



Technical Data	R 850 GS	R 1100 GS
<b>Valve seat ring</b>		
Valve seat angle		
Inlet	45°	45°
Exhaust	45°	30°
		from 1996 mod. year on
Inlet		45°
Exhaust		45°
Valve seat width		
Inlet	mm (in) 1.1 ± 0.15 (0.04331 ± 0.00591)	1.1 ± 0.15 (0.04331 ± 0.00591)
Wear limit	mm (in) 2.5 (0.09843)	2.5 (0.09843)
Exhaust	mm (in) 1.4 ± 0.15 (0.05512 ± 0.00591)	1.4 ± 0.15 (0.05512 ± 0.00591)
Wear limit	mm (in) 3.0 (0.11811)	3.0 (0.11811)
Valve seat extl. dia. (dimension for valve seat machining)		
Inlet	mm (in) 31.4 ± 0.1 (1.23622 ± 0.003937)	35.2 ± 0.1 (1.38583 ± 0.003937)
Exhaust	mm (in) 26.4 ± 0.1 (1.03937 ± 0.003937)	30.3 ± 0.1 (1.19291 ± 0.00393)
		from 1996 mod. year on
Inlet	mm (in)	33.4 ± 0.1 (1.31496 ± 0.00393)
Exhaust	mm (in)	28.4 ± 0.1 (1.11811 ± 0.00393)
Seat ring dia. (oversize +0.2 mm)		
Inlet	mm (in) 34.634...34.650 (1.36254...1.36417)	37.634...37.650 (1.48165...1.48228)
Exhaust	mm (in) 30.134...30.150 (1.186378...1.18701)	34.134...34.150 (1.34386...1.34449)
		from 1996 mod. year on
Inlet	mm (in)	36.617...36.633 (1.44161...1.44224)
Exhaust	mm (in)	32.134...32.150 (1.26512...1.26575)
Seat dia. in cylinder head (oversize +0.2 mm)		
Inlet	mm (in) 34.500...34.525 (1.358268...1.359252)	37.500...37.525 (1.47638...1.47736)
Exhaust	mm (in) 30.000...30.025 (1.1811...1.18209)	34.000...34.025 (1.33859...1.33957)
		from 1996 mod. year on
Inlet	mm (in)	36.500...36.525 (1.43701...1.43799)
Exhaust	mm (in)	32.000...32.025 (1.25984...1.26083)

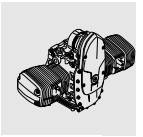

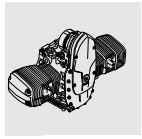

Technical Data			R 850 GS	R 1100 GS
<b>Valve guide</b>				
Valve guide	Extl. dia.	mm (in)	12.533...12.544 (0.49343...0.49386)	12.533...12.544 (0.49343...0.49386)
Bore in cylinder head		mm (in)	12.500...12.518 (0.49213...0.49283)	12.500...12.518 (0.49213...0.49283)
Overlap		mm (in)	0.015...0.044 (0.00059...0.001732)	0.015...0.044 (0.00059...0.001732)
<b>Repair stages</b>				
Replacement valve guide	Extl. dia.	mm (in)	12.550...12.561 (0.49409...0.49453)	12.550...12.561 (0.49409...0.49453)
Oversize valve guide	Extl. dia.	mm (in)	12.733...12.744 (0.501299...0.501732)	12.733...12.744 (0.501299...0.501732)
Valve guide	Intl. dia	mm (in)	5.0...5.012 (0.19685...0.19732)	6.0...6.015 (0.23622...0.23681)
Radial clearance	Inlet	mm (in)	0.020...0.046 (0.000787...0.001811)	0.025...0.055 (0.000984...0.002165)
	Wear limit	mm (in)	0.15 (0.00591)	0.15 (0.00591)
	Exhaust	mm (in)	0.030...0.056 (0.0011811...0.002205)	0.040...0.070 (0.001575...0.002756)
	Wear limit	mm (in)	0.17 (0.006693)	0.17 (0.006693)
Valve guide	Intl. dia	mm (in)		from 1996 mod. year on 5.0...5.012 (0.19685...0.19732)
Radial clearance	Inlet	mm (in)		0.020...0.046 (0.000787...0.001811)
	Wear limit	mm (in)		0.15 (0.00591)
	Exhaust	mm (in)		0.030...0.056 (0.0011811...0.002205)
	Wear limit	mm (in)		0.17 (0.006693)
<b>Valve spring</b>				
Spring length,	off-load	mm (in)	41.1 (1.61811)	41.1 (1.61811)
	Wear limit	mm (in)	39.0 (1.53543)	39.0 (1.53543)
<b>Rocker</b>				
Bore dia.		mm (in)	16.016...16.027 (0.63055...0.63984)	16.016...16.027 (0.63055...0.63984)
Rocker shaft dia.		mm (in)	15.973...15.984 (0.62886...0.62929)	15.973...15.984 (0.62886...0.62929)
Radial clearance		mm (in)	0.032...0.054 (0.001259...0.002126)	0.032...0.054 (0.001259...0.002126)
	Wear limit	mm (in)	0.1 (0.003937)	0.1 (0.003937)
Axial play	min.	mm (in)	0.05 (0.001969)	0.05 (0.001969)
	max.	mm (in)	0.40 (0.01575)	0.40 (0.01575)

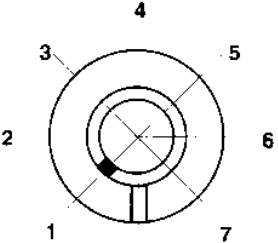
Technical Data	R 850 GS	R 1100 GS
<b>Camshaft</b>		
Opening angle, inlet/exhaust cams Cam spread, inlet/exhaust Marking	300°/284° 103°/112°	300°/284° 103°/112°
	Marking in position <b>1</b>	Marking in position <b>1</b>
Inlet valve lift	mm (in) 9.68 (0.3811) (valve clearance = 0)	9.68 (0.3811) (valve clearance = 0)
Exhaust valve lift	mm (in) 8.55 (0.33661) (valve clearance = 0)	8.55 (0.33661) (valve clearance = 0)
Camshaft bearing bore dia.	mm (in) 21.02...21.04 (0.82756...0.828346)	21.02...21.04 (0.82756...0.828346)
Camshaft dia.	mm (in) 20.97...21.00 (0.82559...0.82677)	20.97...21.00 (0.82559...0.82677)
Radial clearance	mm (in) 0.02...0.07 (0.000787...0.0027559)	0.02...0.07 (0.000787...0.0027559)
Wear limit	mm (in) 0.15 (0.0059055)	0.15 (0.0059055)
Width of guide bearing	mm (in) 15.92...15.95 (0.62677...0.62795)	15.92...15.95 (0.62677...0.62795)
Width of camshaft bearing	mm (in) 16.0...16.05 (0.62992...0.6318897)	16.0...16.05 (0.62992...0.6318897)
Axial play	mm (in) 0.08...0.13 (0.0031496...0.005118)	0.08...0.13 (0.0031496...0.005118)
Wear limit	mm (in) 0.25 (0.0098425)	0.25 (0.0098425)
<b>Bucket-type tappet</b>		
Extl. dia.	mm (in) 23.947...23.960	23.947...23.960
Bore dia. in cylinder head	mm (in) 24.000...24.021 (0.94488...0.94571)	24.000...24.021 (0.94488...0.94571)
Radial clearance	mm (in) 0.040...0.074 (0.00175...0.002913)	0.040...0.074 (0.00175...0.002913)
Wear limit	mm (in) 0.18 (0.0070866)	0.18 (0.0070866)
<b>Auxiliary shaft</b>		
Bore dia. in crankcase front/back	mm (in) 25.020...25.041 (0.98504...0.985866)	25.020...25.041 (0.98504...0.985866)
Auxiliary shaft dia. front/back	mm (in) 24.959...24.980 (0.98264...0.98346)	24.959...24.980 (0.98264...0.98346)
Radial clearance	mm (in) 0.040...0.082 (0.001575...0.003228)	0.040...0.082 (0.001575...0.003228)
Wear limit	mm (in) 0.17 (0.006693)	0.17 (0.006693)

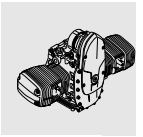

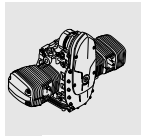

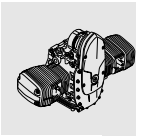

Technical Data		R 850 GS	R 1100 GS
<b>Crankshaft</b>			
Marking of main bearing and crankpin on front crank web			
no paint mark		Grinding stage 0	Grinding stage 0
paint mark		Grinding stage1 (-0.25mm (-0.009843))	Grinding stage 1 (-0.25mm (-0.009843))
Grinding stage 0 (grinding stg. 1=-0.25mm)			
Guide bearing bore dia.	mm (in)	64.949...64.969 (2.557047...2.557834)	64.949...64.969 (2.557047...2.557834)
Guide bearing dia.	mm (in)	Green: 59.964...60.003 (2.36079...2.36232) Yellow: 59.974...60.013 (2.36118...2.36272)	Green: 59.964...60.003 (2.36079...2.36232) Yellow: 59.974...60.013 (2.36118...2.36272)
Main bearing journal dia.	mm (in)	Green: 59.939...59.948 (2.35980...2.360157) Yellow: 59.949...59.958 (2.360197...2.36055)	Green: 59.939...59.948 (2.35980...2.360157) Yellow: 59.949...59.958 (2.360197...2.36055)
Radial clearance	mm (in)	0.016...0.064 (0.0006299..0.002519)	0.016...0.064 (0.0006299..0.002519)
Wear limit	mm (in)	0.1 (0.003937)	0.1 (0.003937)
Main bearing bore dia.	mm (in)	60.000...60.019 (2.3622...2.36295)	60.000...60.019 (2.3622...2.36295)
Main bearing dia.	mm (in)	Green: 54.998...55.039 (2.16528...2.16689) Yellow: 55.008...55.049 (2.16567...2.16728)	Green: 54.998...55.039 (2.16528...2.16689) Yellow: 55.008...55.049 (2.16567...2.16728)
Main bearing journal dia.	mm (in)	Green: 54.971...54.980 (2.1642...2.164567) Yellow: 54.981...54.990 (2.16461...2.16496)	Green: 54.971...54.980 (2.1642...2.164567) Yellow: 54.981...54.990 (2.16461...2.16496)
Radial clearance	mm (in)	0.018...0.068 (0.0001086...002677)	0.018...0.068 (0.0001086...002677)
Wear limit	mm (in)	0.13 (0.005118)	0.13 (0.005118)
Width of guide bearing	mm (in)	24.890...24.940 (0.97992...0.98189)	24.890...24.940 (0.97992...0.98189)
Bearing width of main bearing journal	mm (in)	25.020...25.053 (0.98504...0.986339)	25.020...25.053 (0.98504...0.986339)
Axial play	mm (in)	0.080...0.163 (0.0031496...0.006417)	0.080...0.163 (0.0031496...0.006417)
Wear limit	mm (in)	0.2 (0.007874)	0.2 (0.007874)
Grinding stage 0 (grinding stg. 1 = -0.25mm)			
Crankpin dia.	mm (in)	47.975...47.991 (1.88878...1.88941)	47.975...47.991 (1.88878...1.88941)
Bearing width of crankpin	mm (in)	22.065...22.195 (0.86870...0.87381)	22.065...22.195 (0.86870...0.87381)

Technical Data		R 850 GS	R 1100 GS
<b>Connecting rod</b>			
Big end bore dia.	mm (in)	51.000...51.013 (2.00787...2.008386)	51.000...51.013 (2.00787...2.008386)
Big end bearing dia.	mm (in)	48.016...48.050 (1.89039...1.89173)	48.016...48.050 (1.89039...1.89173)
Radial clearance	mm (in)	0.025...0.075 (0.000984...0.0029527)	0.025...0.075 (0.000984...0.0029527)
Wear limit	mm (in)	0.13 (0.001118)	0.13 (0.001118)
Width of big end bearing eye	mm (in)	21.883...21.935 (0.86154...0.86358)	21.883...21.935 (0.86154...0.86358)
Conrod end float	mm (in)	0.130...0.312 (0.005118...0.0122834)	0.130...0.312 (0.005118...0.0122834)
Wear limit	mm (in)	0.5 (0.019685)	0.5 (0.019685)
Small end bearing bore dia.	mm (in)	22.015...22.025 (0.86673...0.867126)	22.015...22.025 (0.86673...0.867126)
Radial clearance	mm (in)	0.015...0.030 (0.0005905...0.0018)	0.015...0.030 (0.0005905...0.0018)
Wear limit	mm (in)	0.06 (0.0023622)	0.06 (0.0023622)
Distance between centers	mm (in)	125 (4.92126)	125 (4.92126)
Max. deviation from parallel of conrod bores at 150 mm spacing	mm (in)	0.07 (0.0027559)	0.07 (0.0027559)
<b>Cylinders</b>			
Bore		20 mm (0.7874 in) from top edge	20 mm (0.7874 in) from top edge
A	mm (in)	87.492...87.500 (3.444567...3.44489)	98.992...99.000 (3.89732...3.897638)
Wear limit	mm (in)	87.550 (3.44685)	99.050 (3.899606)
B	mm (in)	87.500...87.508 (3.44489...3.4452)	99.000...99.008 (3.897638...3.897953)
Wear limit	mm (in)	87.558 (3.447165)	99.058 (3.899921)
Total wear clearance of piston and cylinder	mm (in)	0.12 (0.0047244)	0.12 (0.0047244)
Permitted out-of-roundness of cylinder bore			
20 mm from the top edge	mm (in)	0.03 (0.0011811)	0.03 (0.0011811)
100 mm from the lower edge	mm (in)	0.04 (0.0015748)	0.04 (0.0015748)
<b>Pistons</b>			
Piston dia.		(Measuring plane A – → see Checking pistons and cylinders)	
A	mm (in)	87.465...87.477 (3.4435...3.443977)	98.965...98.977 (3.89626...3.896732)
Wear limit	mm (in)	87.390 (3.44055)	98.890 (3.8933)
B	mm (in)	87.477...87.485 (3.443976...3.44429)	98.977...98.989 (3.896732...3.897204)
Wear limit	mm (in)	87.400 (3.4409448)	98.900 (3.8937)
AB	mm (in)	87.473...87.481 (3.44382...3.444134)	98.973...98.981 (3.89657...3.8968897)
Wear limit	mm (in)	87.395 (3.44075)	98.895 (3.8935039)
Installed clearance	mm (in)	0.011...0.035 (0.000433...0.0013779)	0.011...0.035 (0.000433...0.0013779)
Total wear clearance of piston and cylinder	mm (in)	0.12 (0.0047244)	0.12 (0.0047244)

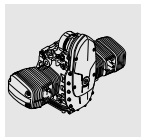



Technical Data		R 850 GS	R 1100 GS
Piston pin bore dia.	mm (in)	22.005...22.011 (0.86634...0.866575)	22.005...22.011 (0.86634...0.866575)
Weight classes		+ and -	+ and -
Weight difference in one class	g (oz.)	10 (0.35) (complete with pins and rings)	10 (0.35) (complete with pins and rings)
Direction of installation		Arrow on piston crown pointing to exhaust side	Arrow on piston crown pointing to exhaust side
		Production locating towards exhaust side (see Installing piston)	Production locating towards exhaust side  (see Installing piston)
<b>Piston rings</b>			
1st groove Micro-taper compression ring	Height	B-Ring SPT TOP 1.170...1.190 (0.04606...0.04685)	1.175...1.190 (0.04626...0.04685)
	Wear limit	mm (in) 1.1 (0.043307)	mm (in) 1.1 (0.043307)
Gap clearance	mm (in)	0.1...0.3 (0.003937...0.0118)	0.1...0.3 (0.003937...0.0118)
	Wear limit	mm (in) 0.8 (0.031496)	mm (in) 0.8 (0.031496)
Side clearance	mm (in)	0.030...0.070 (0.00118...0.0027559)	0.040...0.075 (0.001575...0.002953)
	Wear limit	mm (in) 0.15 (0.00591)	mm (in) 0.15 (0.00591)
2nd groove Micro-taper compression ring	Height	M-Ring m Ø TOP 4 DZ 1.170...1.190 (0.04606...0.04685)	1.175...1.190 (0.04626...0.04685)
	Wear limit	mm (in) 1.1 (0.043307)	mm (in) 1.1 (0.043307)
Gap clearance	mm (in)	0.3...0.5 (0.0118...0.019685)	0.1...0.3 (0.003937...0.0118)
	Wear limit	mm (in) 1.00 (0.03937)	mm (in) 0.8 (0.031496)
Side clearance	mm (in)	0.030...0.070 (0.00118...0.0027559)	0.030...0.065 (0.00118...0.002559)
	Wear limit	mm (in) 0.15 (0.00591)	mm (in) 0.15 (0.00591)
3rd groove Equal-chamfer ring + tubular spring	Height	2.475...2.490 (0.09744...0.09803)	2.475...2.490 (0.09744...0.09803)
	Wear limit	mm (in) 2.4 (0.094488)	mm (in) 2.4 (0.094488)
Gap clearance	mm (in)	0.30...0.60 (0.011811...0.023622)	0.30...0.60 (0.011811...0.023622)
	Wear limit	mm (in) 1.20 (0.047244)	mm (in) 1.20 (0.047244)
Side clearance	mm (in)	0.020...0.060 (0.000787...0.0023622)	0.020...0.055 (0.000787...0.002165)
	Wear limit	mm (in) 0.15 (0.00591)	mm (in) 0.15 (0.00591)
Installed direction of piston rings		"Top" marking uppermost	"Top" marking uppermost
<b>Piston pin</b>			
Piston pin dia.	mm (in)	21.995...22.000 (0.86594...0.86614)	21.995...22.000 (0.86594...0.86614)
	Wear limit	mm (in) 21.960 (0.864567)	mm (in) 21.960 (0.864567)
Bore dia. in piston	mm (in)	22.005...22.011 (0.866339...0.8665748)	22.005...22.011 (0.866339...0.8665748)
Radial clearance in piston	mm (in)	0.005...0.016 (0.000197...0.0006299)	0.005...0.016 (0.000197...0.0006299)
	Wear limit	mm (in) 0.070 (0.0027559)	mm (in) 0.070 (0.0027559)

Technical Data	R 850 R	R 1100 R
<b>Engine, general</b>		
Engine design	Four-stroke flat twin, air-cooled with oil-cooled exhaust ports, installed longitudinally, 4 valves per cylinder, two high-mounted camshafts, electronic fuel injection.	
Location of engine number	Crankcase	
Cylinder bore	mm (in) 87.5 (3.445)	99.0 (3.898)
Stroke	mm (in) 70.5 (2.776)	70.5 (2.776)
Effective displacement	cc 848	1085
Compression ratio	10.3 : 1	10.3 : 1
Power output	kW(bhp)/min <sup>-1</sup> 52(70)/7000	59(80)/6750
Max. torque	Nm/min <sup>-1</sup> 77/5500	97/5250
Permissible maximum engine speed	min <sup>-1</sup> 8100	7800
Permissible continuous engine speed	min <sup>-1</sup> 7800	7600
Idle speed	min <sup>-1</sup> 1000 <sup>+150</sup>	1000 <sup>+150</sup>
Direction of rotation	Clockwise, looking at ignition system	Clockwise, looking at ignition system
Compression test pressure		
good	bar (psi) above 10 (145.04)	above 10 (145.04)
normal	bar (psi) 8.5...10 (123.28...145.04)	8.5...10 (123.28...145.04)
poor	bar (psi) below 8.5(123.28)	below 8.5(123.28)
Intake port dia./cylinder head	mm (in) 44 (1.732)	44 (1.732)
<b>Lubrication system</b>		
Theoretical volume in circulation at 6000 min <sup>-1</sup>		
Lubricating oil	l (Imp. pints) 36 (63.36)	36 (63.36)
Cooling oil	l (Imp. pints) 30 (52.8)	30 (52.8)
Oil filter	Full-flow type	Full-flow type
Pressure differential needed to open bypass valve	bar (psi) 1.5 (21.756)	1.5 (21.756)
Oil pressure warning light comes on below	bar (psi) 0.2...0.5 (2.9...7.25)	0.2...0.5 (2.9...7.25)
Pressure relief valve opens at	bar (psi) 5.5 (79.77)	5.5 (79.77)
Operating pressure	bar (psi) 3.5...6.0 (50.76...87.02)	3.5...6.0 (50.76...87.02)
Oil content		
without filter change	l (Imp. pints) 3.50 (6.16)	3.50 (6.16)
with filter change	l (Imp. pints) 3.75 (6.6)	3.75 (6.6)
min/max	l (Imp. pints) 0.50 (0.88)	0.50 (0.88)
Permissible oil consumption	l/1000 km Imp.pint/miles 1.0 (1.41/500)	1.0 (1.41/500)
<b>Oil pump</b>		
Oil pump	2 Duocentric pumps	2 Duocentric pumps
Housing depth	mm (in) 12.02...12.05 (0.47322...0.47441)	12.02...12.05 (0.47322...0.47441)
	mm (in) 10.02...10.05 (0.3945...0.3957)	10.02...10.05 (0.3945...0.3957)
Height of rotor	mm (in) 11.95...11.98 (0.4705...0.4717)	11.95...11.98 (0.4705...0.4717)
	mm (in) 9.95...9.98 (0.3917...0.3929)	9.95...9.98 (0.3917...0.3929)
Axial play	mm (in) 0.04...0.1 (0.0016...0.0039)	0.04...0.1 (0.0016...0.0039)
Wear limit	mm (in) 0.25 (0.0098)	0.25 (0.0098)

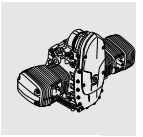

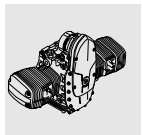

Technical Data		R 850 R	R 1100 R
<b>Valves</b>			
Included angle between valves		° 41	41
Valve clearances, engine cold (max. 35 °C)			
Inlet valve	mm (in)	0.15 (0.0059)	0.15 (0.0059)
Exhaust valve	mm (in)	0.30 (0.0118)	0.30 (0.0118)
Valve timing		At zero valve clearance and 3 mm (0.1181 in) valve lift	
Inlet opens		1° before TDC	1° before TDC
Inlet closes		29° after BDC	29° after BDC
Exhaust opens		28° before BDC	28° before BDC
Exhaust closes		16° before TDC	16° before TDC
		Toleranz ± 3°	Toleranz ± 3°
Valve head dia.			
Inlet	mm (in)	32 (1.25984)	36 (1.4173)
Exhaust	mm (in)	27 (1.06299)	31(1.2205)
Inlet	mm (in)		from 1996 mod. year on 34 (1.3386)
Exhaust	mm (in)		29 (1.1417)
Stem dia.			
Inlet	mm (in)	4.966...4.980 (0.16551...0.19606)	5.960...5.975 (0.23465...0.23524)
Wear limit	mm (in)	4.946 (0.19472)	5.940 (0.23386)
Exhaust	mm (in)	4.956..4.970 (0.19512...0.19567)	5.945...5.960 (0.23406...0.23465)
Wear limit	mm (in)	4.936 (0.19433)	5.925 (0.23327)
Inlet	mm (in)		ab Mj. 96 4.966...4.980 (0.16551...0.19606)
Wear limit	mm (in)		4.946 (0.19472)
Exhaust	mm (in)		4.956..4.970 (0.19512...0.19567)
Wear limit	mm (in)		4.936 (0.19433)
Valve head edge thickness			
Inlet	mm (in)	1.00 ± 0.2 (0.03937 ± 0.00787)	1.00 ± 0.2 (0.03937 ± 0.00787)
Wear limit	mm (in)	0.5 (0.01969)	0.5 (0.01969)
Exhaust	mm (in)	1.00 ± 0.2 (0.03937 ± 0.00787)	1.65 ± 0.2 (0.06496 ± 0.00787)
Wear limit	mm (in)	0.5 (0.01969)	1.0 (0.03937)
Inlet	mm (in)		from 1996 mod. year on 1.00 ± 0.2 (0.03937 ± 0.00787)
Wear limit	mm (in)		0.5 (0.01969)
Exhaust	mm (in)		1.00 ± 0.2 (0.03937 ± 0.00787)
Wear limit	mm (in)		0.5 (0.01969)
Max. runout of valve head at valve seat			
Inlet, exhaust	mm (in)	0.035 (0.001378)	0.035 (0.001378)



Technical Data		R 850 R	R 1100 R
<b>Valve seat ring</b>			
Valve seat angle			
Inlet		45°	45°
Exhaust		45°	30°
			from 1996 mod. year on
Inlet			45°
Exhaust			45°
Valve seat width			
Inlet	mm (in)	1.1 ± 0.15 (0.04331 ± 0.00591)	1.1 ± 0.15 (0.04331 ± 0.00591)
Wear limit	mm (in)	2.5 (0.09843)	2.5 (0.09843)
Exhaust	mm (in)	1.4 ± 0.15 (0.05512 ± 0.00591)	1.4 ± 0.15 (0.05512 ± 0.00591)
Wear limit	mm (in)	3.0 (0.11811)	3.0 (0.11811)
Valve seat extl. dia. (dimension for valve seat machining)			
Inlet	mm (in)	31.4 ± 0.1 (1.23622 ± 0.003937)	35.2 ± 0.1 (1.38583 ± 0.003937)
Exhaust	mm (in)	26.4 ± 0.1 (1.03937 ± 0.003937)	30.3 ± 0.1 (1.19291 ± 0.00393)
			from 1996 mod. year on
Inlet	mm (in)		33.4 ± 0.1 (1.31496 ± 0.00393)
Exhaust	mm (in)		28.4 ± 0.1 (1.11811 ± 0.00393)
Seat ring dia. (oversize +0.2 mm)			
Inlet	mm (in)	34.634...34.650 (1.36254...1.36417)	37.634...37.650 (1.48165...1.48228)
Exhaust	mm (in)	30.134...30.150 (1.186378...1.18701)	34.134...34.150 (1.34386...1.34449)
			from 1996 mod. year on
Inlet	mm (in)		36.617...36.633 (1.44161...1.44224)
Exhaust	mm (in)		32.134...32.150 (1.26512...1.26575)
Seat dia. in cylinder head (oversize +0.2 mm)			
Inlet	mm (in)	34.500...34.525 (1.358268...1.359252)	37.500...37.525 (1.47638...1.47736)
Exhaust	mm (in)	30.000...30.025 (1.1811...1.18209)	34.000...34.025 (1.33859...1.33957)
			from 1996 mod. year on
Inlet	mm (in)		36.500...36.525 (1.43701...1.43799)
Exhaust	mm (in)		32.000...32.025 (1.25984...1.26083)

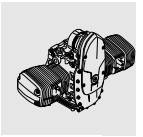

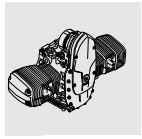

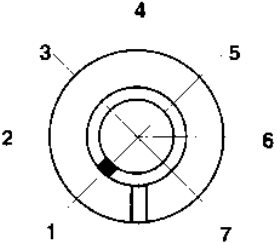

Technical Data				R 850 R	R 1100 R
<b>Valve guide</b>					
Valve guide	Extl. dia.	mm (in)	12.533...12.544 (0.49343...0.49386)	12.533...12.544 (0.49343...0.49386)	
Bore in cylinder head		mm (in)	12.500...12.518 (0.49213...0.49283)	12.500...12.518 (0.49213...0.49283)	
Overlap		mm (in)	0.015...0.044 (0.00059...0.001732)	0.015...0.044 (0.00059...0.001732)	
<b>Repair stages</b>					
Replacement valve guide	Extl. dia.	mm (in)	12.550...12.561 (0.49409...0.49453)	12.550...12.561 (0.49409...0.49453)	
Oversize valve guide	Extl. dia.	mm (in)	12.733...12.744 (0.501299...0.501732)	12.733...12.744 (0.501299...0.501732)	
Valve guide	Intl. dia.	mm (in)	5.0...5.012 (0.19685...0.19732)	6.0...6.015 (0.23622...0.23681)	
Radial clearance	Inlet	mm (in)	0.020...0.046 (0.000787...0.001811)	0.025...0.055 (0.000984...0.002165)	
	Wear limit	mm (in)	0.15 (0.00591)	0.15 (0.00591)	
	Exhaust	mm (in)	0.030...0.056 (0.0011811...0.002205)	0.040...0.070 (0.001575...0.002756)	
	Wear limit	mm (in)	0.17 (0.006693)	0.17 (0.006693)	
Valve guide	Intl. dia.	mm (in)		from 1996 mod. year on 5.0...5.012 (0.19685...0.19732)	
Radial clearancel	Inlet	mm (in)		0.020...0.046 (0.000787...0.001811)	
	Wear limit	mm (in)		0.15 (0.00591)	
	Exhaust	mm (in)		0.030...0.056 (0.0011811...0.002205)	
	Wear limit	mm (in)		0.17 (0.006693)	
<b>Valve spring</b>					
Spring length,	off-load	mm (in)	41.1 (1.61811)	41.1 (1.61811)	
	Wear limit	mm (in)	39.0 (1.53543)	39.0 (1.53543)	
<b>Rocker</b>					
Bore dia.		mm (in)	16.016...16.027 (0.63055...0.63984)	16.016...16.027 (0.63055...0.63984)	
Rocker shaft dia.		mm (in)	15.973...15.984 (0.62886...0.62929)	15.973...15.984 (0.62886...0.62929)	
Radial clearance		mm (in)	0.032...0.054 (0.001259...0.002126)	0.032...0.054 (0.001259...0.002126)	
	Wear limit	mm (in)	0.1 (0.003937)	0.1 (0.003937)	
Axial play	min.	mm (in)	0.05 (0.001969)	0.05 (0.001969)	
	max.	mm (in)	0.40 (0.01575)	0.40 (0.01575)	

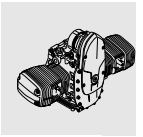
Technical Data	R 850 R	R 1100 R
<b>Camshaft</b>		
Opening angle, inlet/exhaust cams Cam spread, inlet/exhaust Marking	300°/284° 103°/112°	300°/284° 103°/112°
	Marking in position <b>1</b>	Marking in position <b>1</b>
Inlet valve lift	mm (in) 9.68 (0.3811) (valve clearance = 0)	9.68 (0.3811) (valve clearance = 0)
Exhaust valve lift	mm (in) 8.55 (0.33661) (valve clearance = 0)	8.55 (0.33661) (valve clearance = 0)
Camshaft bearing bore dia.	mm (in) 21.02...21.04 (0.82756...0.828346)	21.02...21.04 (0.82756...0.828346)
Camshaft dia.	mm (in) 20.97...21.00 (0.82559...0.82677)	20.97...21.00 (0.82559...0.82677)
Radial clearance	mm (in) 0.02...0.07 (0.000787...0.0027559)	0.02...0.07 (0.000787...0.0027559)
Wear limit	mm (in) 0.15 (0.0059055)	0.15 (0.0059055)
Width of guide bearing	mm (in) 15.92...15.95 (0.62677...0.62795)	15.92...15.95 (0.62677...0.62795)
Width of camshaft bearing	mm (in) 16.0...16.05 (0.62992...0.6318897)	16.0...16.05 (0.62992...0.6318897)
Axial play	mm (in) 0.08...0.13 (0.0031496...0.005118)	0.08...0.13 (0.0031496...0.005118)
Wear limit	mm (in) 0.25 (0.0098425)	0.25 (0.0098425)
<b>Bucket-type tappet</b>		
Extl. dia.	mm (in) 23.947...23.960	23.947...23.960
Bore dia. in cylinder head	mm (in) 24.000...24.021 (0.94488...0.94571)	24.000...24.021 (0.94488...0.94571)
Radial clearance	mm (in) 0.040...0.074 (0.00175...0.002913)	0.040...0.074 (0.00175...0.002913)
Wear limit	mm (in) 0.18 (0.0070866)	0.18 (0.0070866)
<b>Auxiliary shaft</b>		
Bore dia. in crankcase front/back	mm (in) 25.020...25.041 (0.98504...0.985866)	25.020...25.041 (0.98504...0.985866)
Auxiliary shaft dia. front/back	mm (in) 24.959...24.980 (0.98264...0.98346)	24.959...24.980 (0.98264...0.98346)
Radial clearance	mm (in) 0.040...0.082 (0.001575...0.003228)	0.040...0.082 (0.001575...0.003228)
Wear limit	mm (in) 0.17 (0.006693)	0.17 (0.006693)

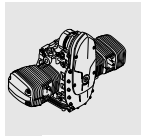



Technical Data	R 850 R	R 1100 R
<b>Crankshaf</b>		
Marking of main bearing and crankpin on front crank web no paint mark paint mark	Grinding stage 0 Grinding stage 1 (-0.25mm (-0.009843))	Grinding stage 0 Grinding stage 1 (-0.25mm (-0.009843))
Grinding stage 0 (grinding stage 1= -0.25mm)		
Guide bearing bore dia. mm (in)	64.949...64.969 (2.557047...2.557834)	64.949...64.969 (2.557047...2.557834)
Guide bearing dia. mm (in)	Green: 59.964...60.003 (2.36079...2.36232) Yellow: 59.974...60.013 (2.36118...2.36272)	Green: 59.964...60.003 (2.36079...2.36232) Yellow: 59.974...60.013 (2.36118...2.36272)
Main bearing journal dia. mm (in)	Green: 59.939...59.948 (2.35980...2.360157) Yellow: 59.949...59.958 (2.360197...2.36055)	Green: 59.939...59.948 (2.35980...2.360157) Yellow: 59.949...59.958 (2.360197...2.36055)
Radial clearance mm (in)	0.016...0.064 (0.0006299..0.002519)	0.016...0.064 (0.0006299..0.002519)
Wear limit mm (in)	0.1 (0.003937)	0.1 (0.003937)
Main bearing bore dia. mm (in)	60.000...60.019 (2.3622...2.36295)	60.000...60.019 (2.3622...2.36295)
Main bearing dia. mm (in)	Green: 54.998...55.039 (2.16528...2.16689) Yellow: 55.008...55.049 (2.16567...2.16728)	Green: 54.998...55.039 (2.16528...2.16689) Yellow: 55.008...55.049 (2.16567...2.16728)
Main bearing journal dia. mm (in)	Green: 54.971...54.980 (2.1642...2.164567) Yellow: 54.981...54.990 (2.16461...2.16496)	Green: 54.971...54.980 (2.1642...2.164567) Yellow: 54.981...54.990 (2.16461...2.16496)
Radial clearance mm (in)	0.018...0.068 (0.0001086...002677)	0.018...0.068 (0.0001086...002677)
Wear limit mm (in)	0.13 (0.005118)	0.13 (0.005118)
Width of guide bearing mm (in)	24.890...24.940 (0.97992...0.98189)	24.890...24.940 (0.97992...0.98189)
Bearing width of main bearing journal mm (in)	25.020...25.053 (0.98504...0.986339)	25.020...25.053 (0.98504...0.986339)
Axial play mm (in)	0.080...0.163 (0.0031496...0.006417)	0.080...0.163 (0.0031496...0.006417)
Wear limit mm (in)	0.2 (0.007874)	0.2 (0.007874)
Grinding stage 0 (grinding stage1= -0.25mm)		
Crankpin dia. mm (in)	47.975...47.991 (1.88878...1.88941)	47.975...47.991 (1.88878...1.88941)
Bearing width of crankpin mm (in)	22.065...22.195 (0.86870...0.87381)	22.065...22.195 (0.86870...0.87381)

Technical Data		R 850 R	R 1100 R
<b>Connecting rod</b>			
Big end bore dia.	mm (in)	51.000...51.013 (2.00787...2.008386)	51.000...51.013 (2.00787...2.008386)
Big end bearing dia.	mm (in)	48.016...48.050 (1.89039...1.89173)	48.016...48.050 (1.89039...1.89173)
Radial clearance	mm (in)	0.025...0.075 (0.000984...0.0029527)	0.025...0.075 (0.000984...0.0029527)
Wear limit	mm (in)	0.13 (0.001118)	0.13 (0.001118)
Width of big end bearing eye	mm (in)	21.883...21.935 (0.86154...0.86358)	21.883...21.935 (0.86154...0.86358)
Conrod end float	mm (in)	0.130...0.312 (0.005118...0.0122834)	0.130...0.312 (0.005118...0.0122834)
Wear limit	mm (in)	0.5 (0.019685)	0.5 (0.019685)
Small end bearing bore dia.	mm (in)	22.015...22.025 (0.86673...0.867126)	22.015...22.025 (0.86673...0.867126)
Radial clearance	mm (in)	0.015...0.030 (0.0005905...0.0018)	0.015...0.030 (0.0005905...0.0018)
Wear limit	mm (in)	0.06 (0.0023622)	0.06 (0.0023622)
Distance between centers	mm (in)	125 (4.92126)	125 (4.92126)
Max. deviation from parallel of conrod bores at 150 mm spacing	mm (in)	0.07 (0.0027559)	0.07 (0.0027559)
<b>Cylinders</b>			
Bore		20 mm (0.7874 in) from top edge	20 mm (0.7874 in) from top edge
A	mm (in)	87.492...87.500 (3.444567...3.44489)	98.992...99.000 (3.89732...3.897638)
Wear limit	mm (in)	87.550 (3.44685)	99.050 (3.899606)
B	mm (in)	87.500...87.508 (3.44489...3.4452)	99.000...99.008 (3.897638...3.897953)
Wear limit	mm (in)	87.558 (3.447165)	99.058 (3.899921)
Total wear clearance of piston and cylinder	mm (in)	0.12 (0.0047244)	0.12 (0.0047244)
Permitted out-of-roundness of cylinder bore			
20 mm from the top edge	mm (in)	0.03 (0.0011811)	0.03 (0.0011811)
100 mm from the lower edge	mm (in)	0.04 (0.0015748)	0.04 (0.0015748)
<b>Pistons</b>			
Piston dia.		(Measuring plane A –  see Checking pistons and cylinders)	
A	mm (in)	87.465...87.477 (3.4435...3.443977)	98.965...98.977 (3.89626...3.896732)
Wear limit	mm (in)	87.390 (3.44055)	98.890 (3.8933)
B	mm (in)	87.477...87.485 (3.443976...3.44429)	98.977...98.989 (3.896732...3.897204)
Wear limit	mm (in)	87.400 (3.4409448)	98.900 (3.8937)
AB	mm (in)	87.473...87.481 (3.44382...3.444134)	98.973...98.981 (3.89657...3.8968897)
Wear limit	mm (in)	87.395 (3.44075)	98.895 (3.8935039)
Installed clearance	mm (in)	0.011...0.035 (0.000433...0.0013779)	0.011...0.035 (0.000433...0.0013779)
Total wear clearance of piston and cylinder	mm (in)	0.12 (0.0047244)	0.12 (0.0047244)

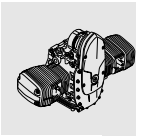

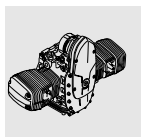

Technical Data		R 850 R	R 1100 R
Piston pin bore dia.	mm (in)	22.005...22.011 (0.86634...0.866575)	22.005...22.011 (0.86634...0.866575)
Weight classes		+ and -	+ and -
Weight difference in one class	g (oz.)	10 (0.35) (complete with pins and rings)	10 (0.35) (complete with pins and rings)
Direction of installation		Arrow on piston crown pointing to exhaust side	Arrow on piston crown pointing to exhaust side
		Production location towards exhaust side (see Installing Piston)	Production location towards exhaust side (see Installing Piston)
<b>Piston rings</b>			
1st groove Micro-taper compression ring	Height	B-Ring SPT TOP 1.170...1.190 (0.04606...0.04685)	1.175...1.190 (0.04626...0.04685)
	Wear limit	mm (in) 1.1 (0.043307)	mm (in) 1.1 (0.043307)
Gap clearance	mm (in)	0.1...0.3 (0.003937...0.0118)	0.1...0.3 (0.003937...0.0118)
	Wear limit	mm (in) 0.8 (0.031496)	mm (in) 0.8 (0.031496)
Side clearance	mm (in)	0.030...0.070 (0.00118...0.0027559)	0.040...0.075 (0.001575...0.002953)
	Wear limit	mm (in) 0.15 (0.00591)	mm (in) 0.15 (0.00591)
2nd groove Micro-taper compression ring	Height	M-Ring m Ø TOP 4 DZ 1.170...1.190 (0.04606...0.04685)	1.175...1.190 (0.04626...0.04685)
	Wear limit	mm (in) 1.1 (0.043307)	mm (in) 1.1 (0.043307)
Gap clearance	mm (in)	0.3...0.5 (0.0118...0.019685)	0.1...0.3 (0.003937...0.0118)
	Wear limit	mm (in) 1.00 (0.03937)	mm (in) 0.8 (0.031496)
Side clearance	mm (in)	0.030...0.070 (0.00118...0.0027559)	0.030...0.065 (0.00118...0.002559)
	Wear limit	mm (in) 0.15 (0.00591)	mm (in) 0.15 (0.00591)
3rd groove Equal-chamfer ring + tubular spring	Height	2.475...2.490 (0.09744...0.09803)	2.475...2.490 (0.09744...0.09803)
	Wear limit	mm (in) 2.4 (0.094488)	mm (in) 2.4 (0.094488)
Gap clearance	mm (in)	0.30...0.60 (0.011811...0.023622)	0.30...0.60 (0.011811...0.023622)
	Wear limit	mm (in) 1.20 (0.047244)	mm (in) 1.20 (0.047244)
Side clearance	mm (in)	0.020...0.060 (0.000787...0.0023622)	0.020...0.055 (0.000787...0.002165)
	Wear limit	mm (in) 0.15 (0.00591)	mm (in) 0.15 (0.00591)
Installed direction of piston rings		"Top" marking uppermost	"Top" marking uppermost
<b>Piston pin</b>			
Piston pin dia.	mm (in)	21.995...22.000 (0.86594...0.86614)	21.995...22.000 (0.86594...0.86614)
	Wear limit	mm (in) 21.960 (0.864567)	mm (in) 21.960 (0.864567)
Bore dia. in piston	mm (in)	22.005...22.011 (0.866339...0.8665748)	22.005...22.011 (0.866339...0.8665748)
Radial clearance in piston	mm (in)	0.005...0.016 (0.000197...0.0006299)	0.005...0.016 (0.000197...0.0006299)
	Wear limit	mm (in) 0.070 (0.0027559)	mm (in) 0.070 (0.0027559)

# Sectioned drawing of engine

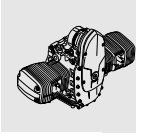
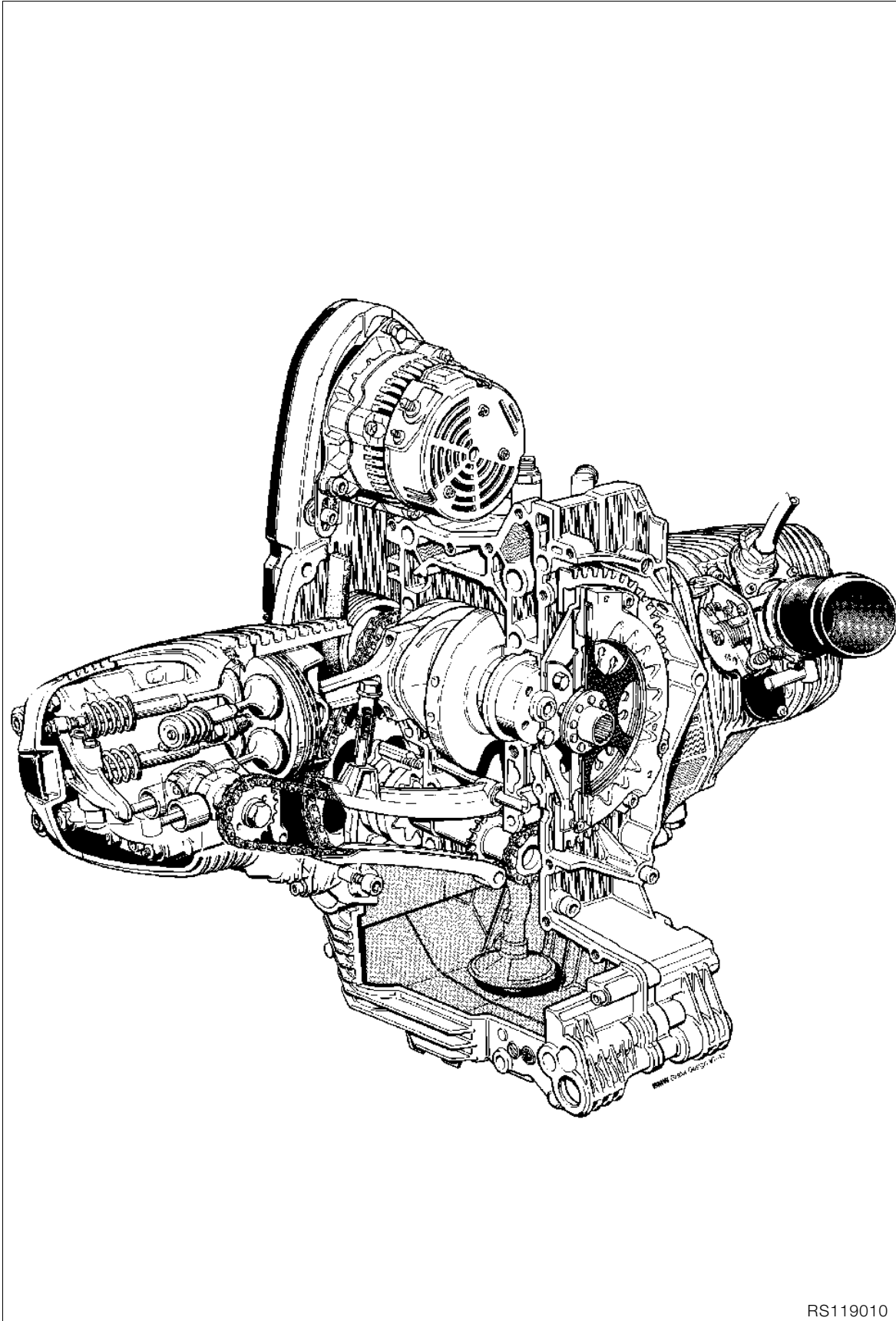

RS119010

## Lubricating oil circuit

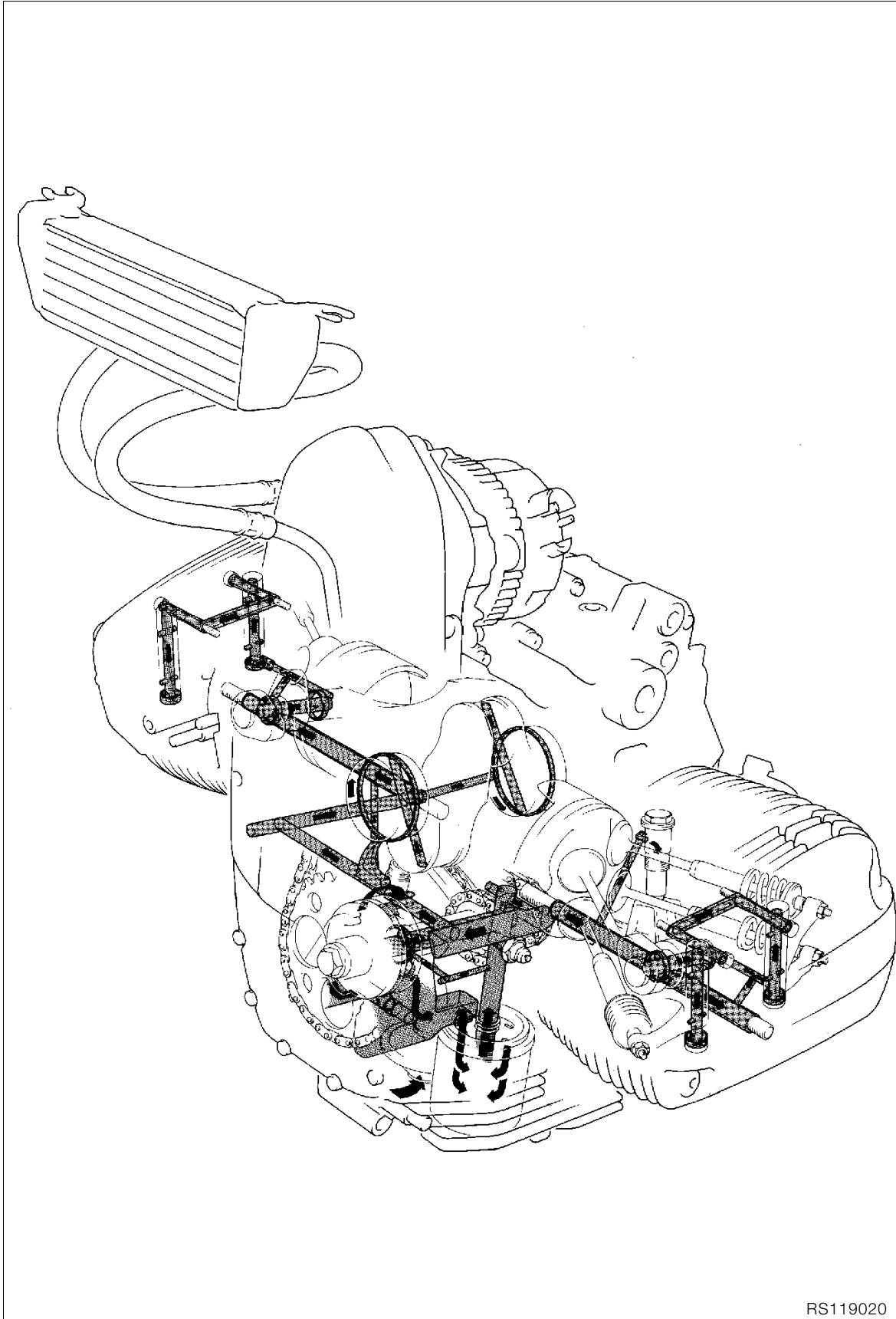
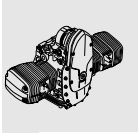

RS119020



## Coolant circuit

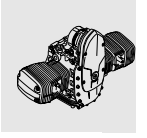
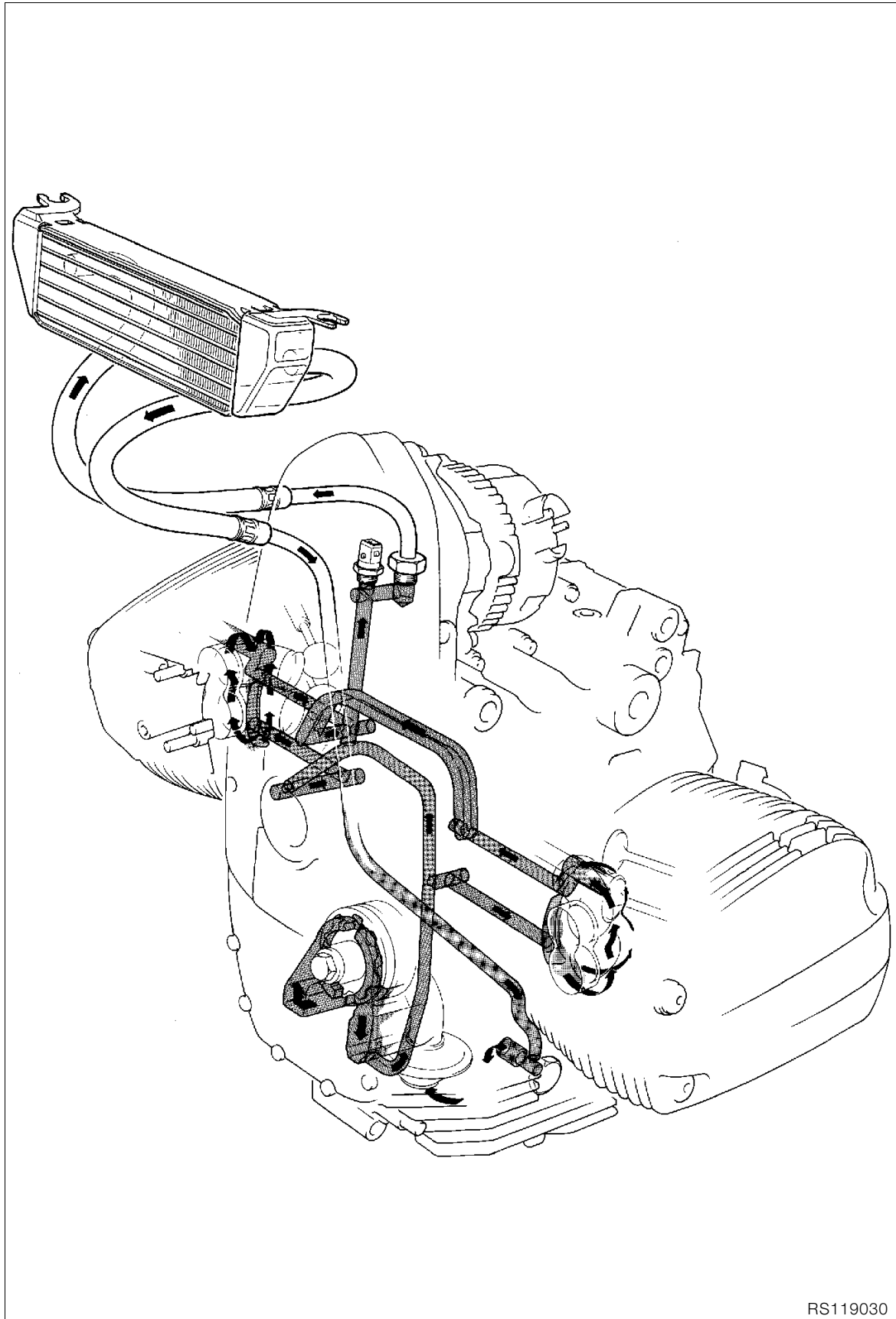

RS119030

## Cooling oil circuit (with oil thermostat)

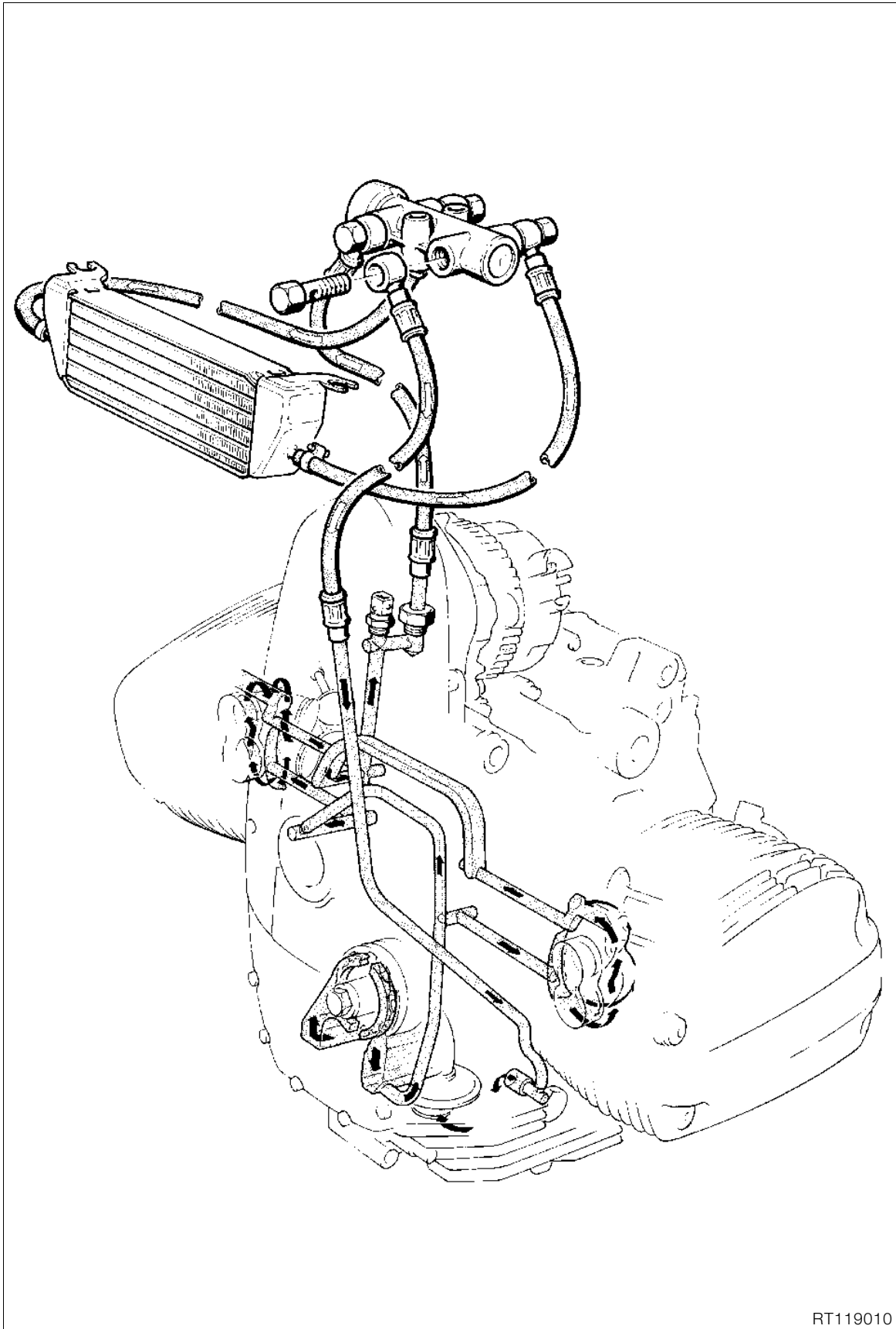
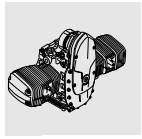

RT119010

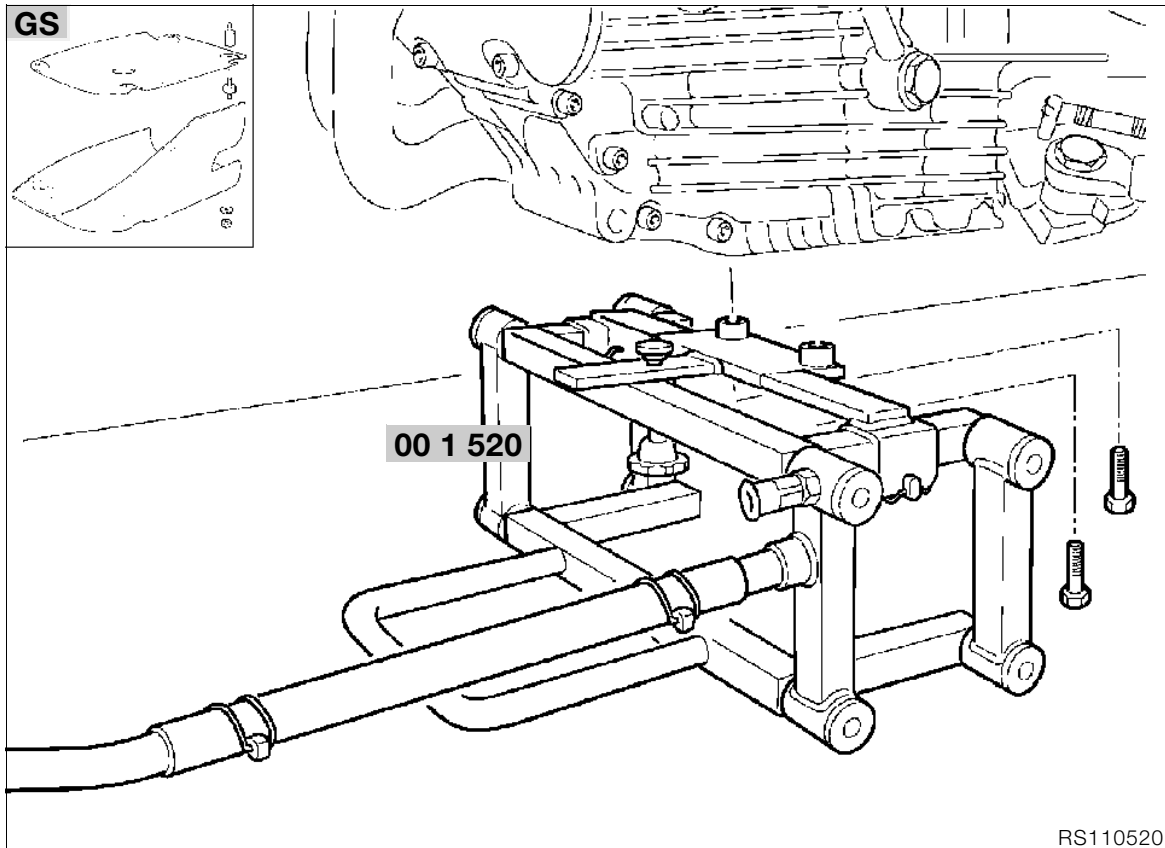

## Removing engine



### Note:

Auxiliary shaft, timing chains, chain tensioner/guide rails and crankshaft can only be dismantled after the engine has been removed. All other components can be dismantled while the engine is still installed.

- Drain engine oil.
- **[RT]** Remove lower section of fairing.
- Attach stand, **BMW No. 00 1 520** to motorcycle.
- **[GS]** Use extension bushings and bolts, **BMW No. 00 1 527**.

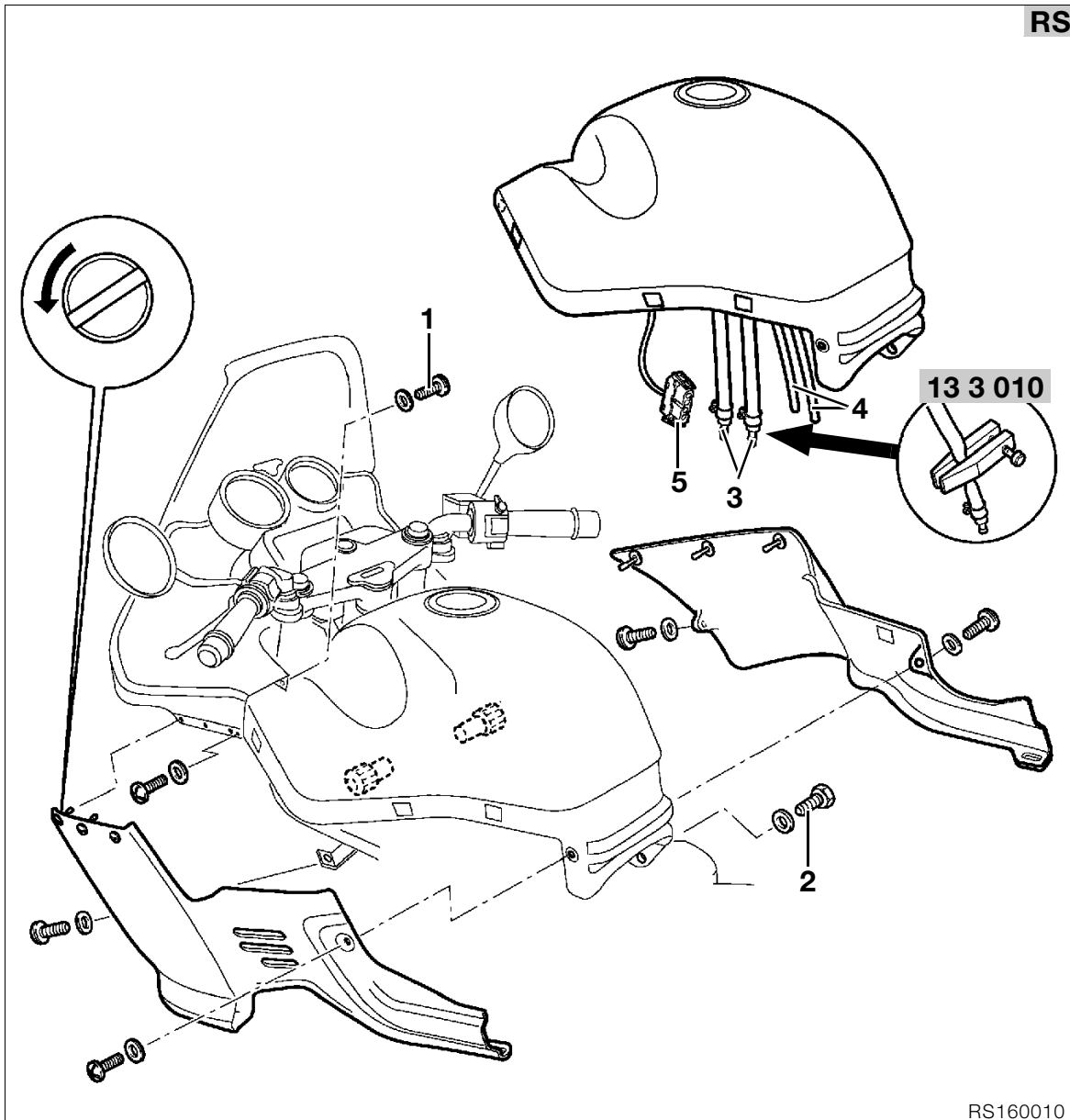
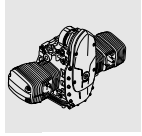

- Remove dual seat.
- **[RS/GS/RT]** Remove side sections of fairing.
- **[RS]** Detach inner cockpit panel (1) at fuel tank.
- **[R]** Unscrew fuel tank cover.
- **[RT]** Detach storage compartment from tank.
- Unfasten fuel tank mount (2).
- Seal, loosen and pull off fuel feed and return line (3) with hose clip, **BMW No. 13 3 010**.
- Remove vent pipes (4).
- Remove connector at fuel pump (5).
- Remove fuel tank.

RT

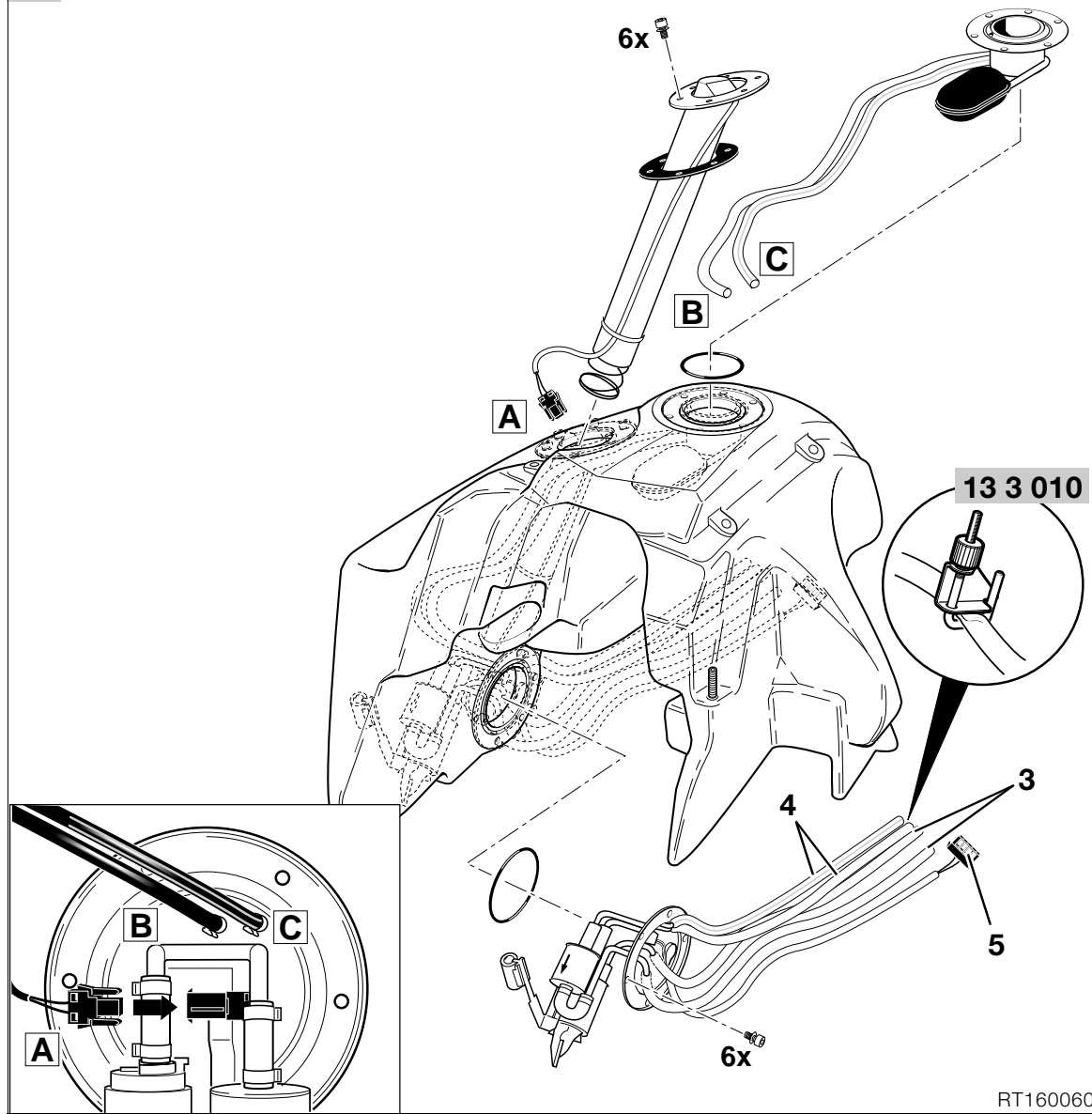

RT160060

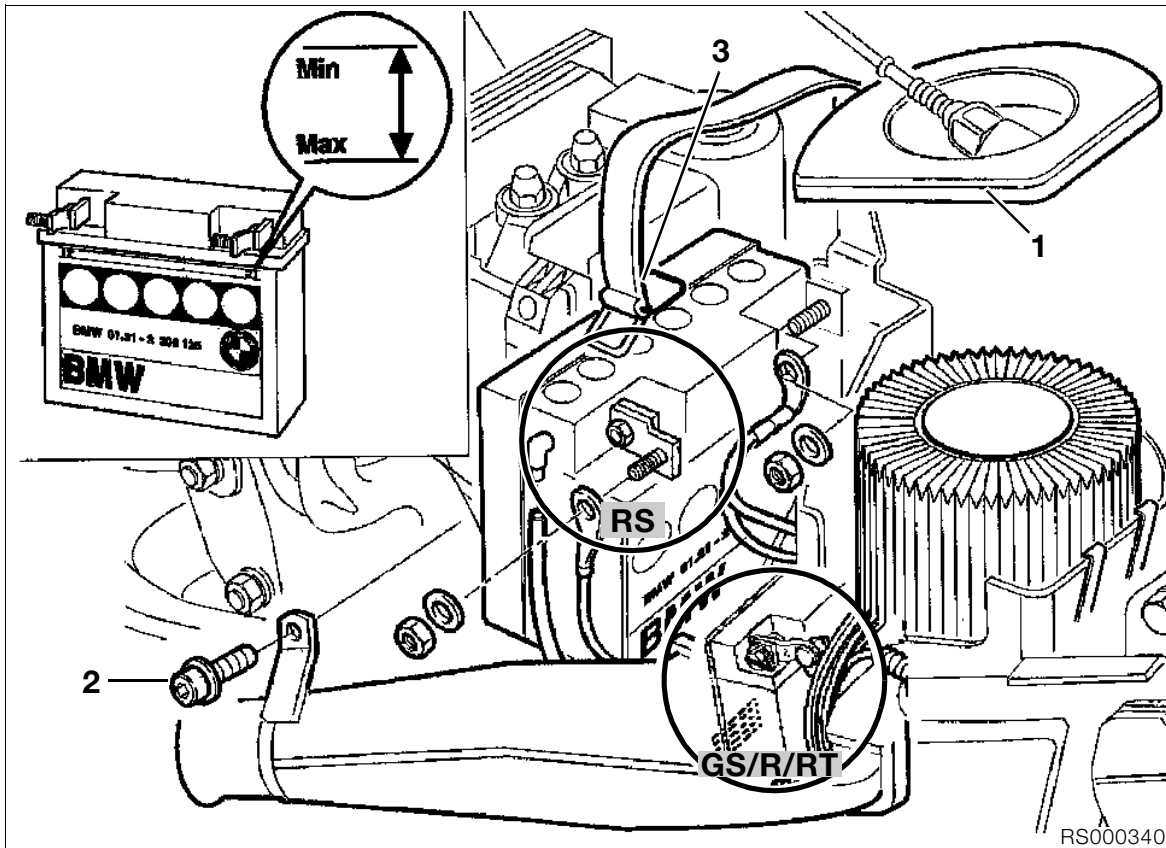
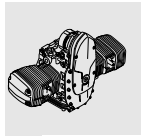

- Remove air filter cover (1) and air intake pipe (2).
- Remove battery (3).

**⚠ Caution:**  
Disconnect negative terminal first, then positive terminal.

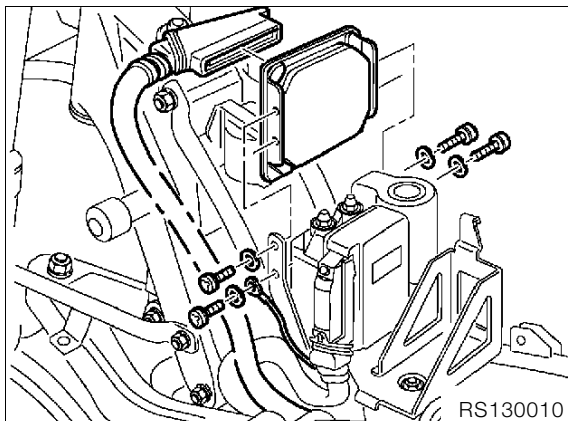

- Remove Motronic control unit.

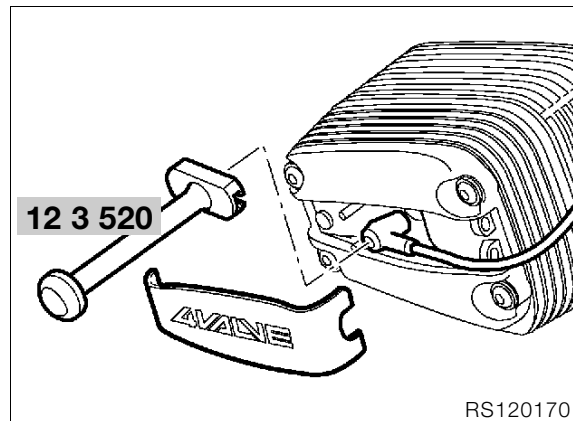

- Remove spark plug covers.
- Pull off spark plug caps with puller, **BMW No. 12 3 520.**

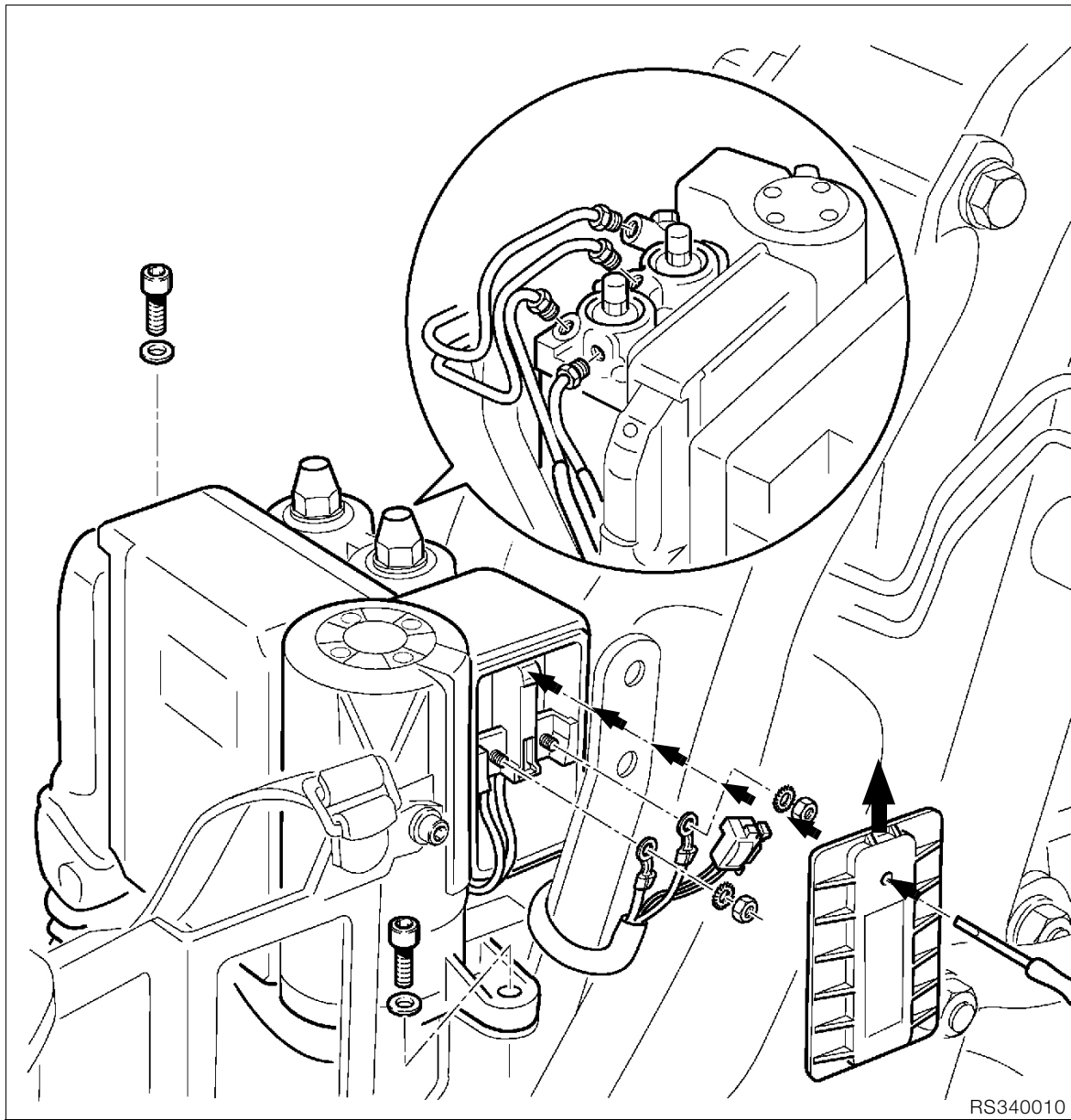

RS340010

- [ABS] unit - remove.



**Note:**

Retain brake lines with cable straps.



**Caution:**

Always follow the instructions in the repair manual  
 See Group 34, Removing and installing ABS unit.

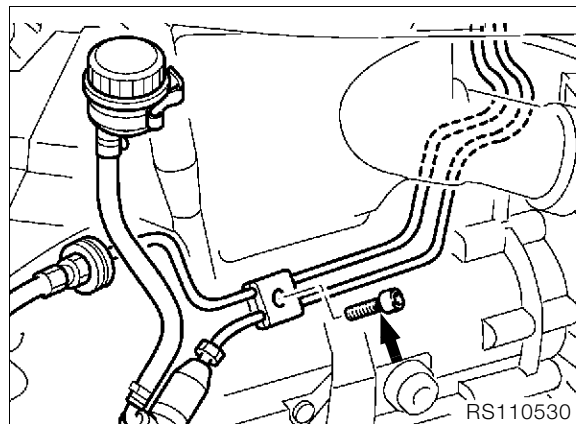

RS110530

- [ABS] Detach brake pipes at gearbox.
- [RT] Detach brake master cylinder.

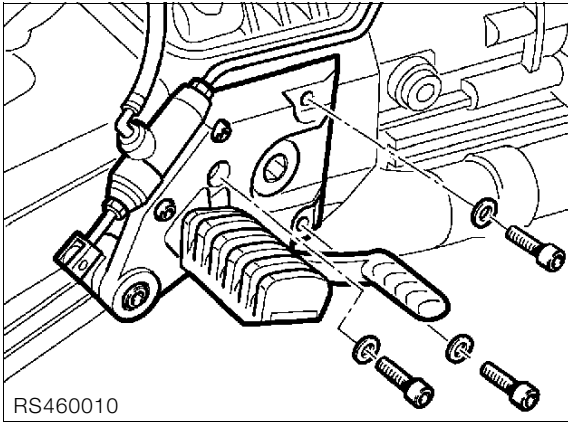
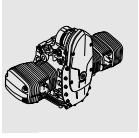

RS460010

- **[RT]** Detach brake master cylinder.
- Unfasten right footrest plate

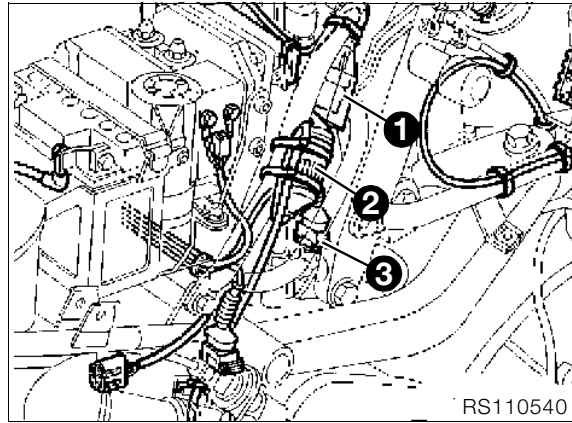

RS110540

- Separate connector/Hall-effect transmitter wire (1).
- Separate connector/oxygen sensor (2).
- Pull off plug/NTC-oil temperature (3).

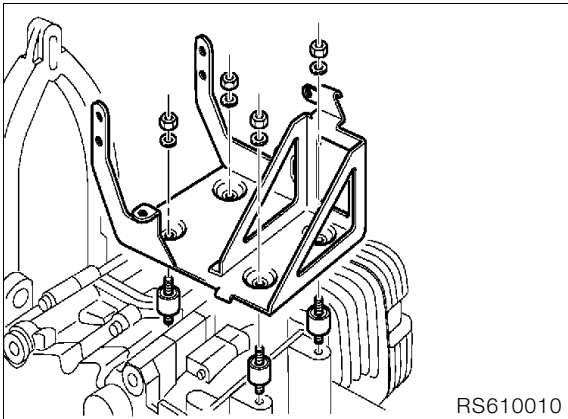

RS610010

- Detach wire cable junction block.
- Remove battery holder

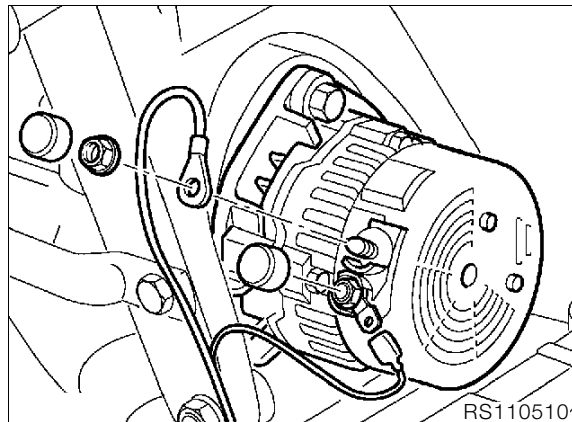

RS110510

- Detach leads from alternator.

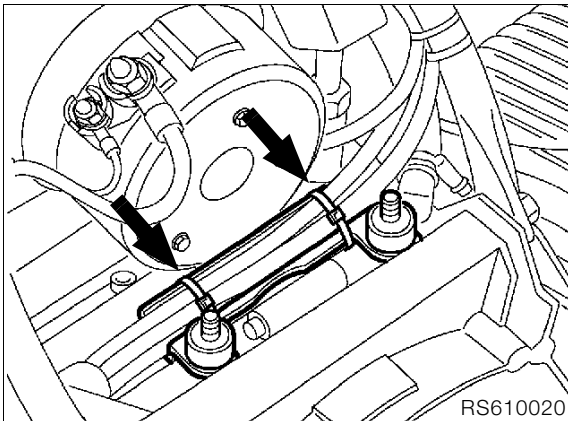

RS610020

- Remove cable strap from cable guide under battery holder.

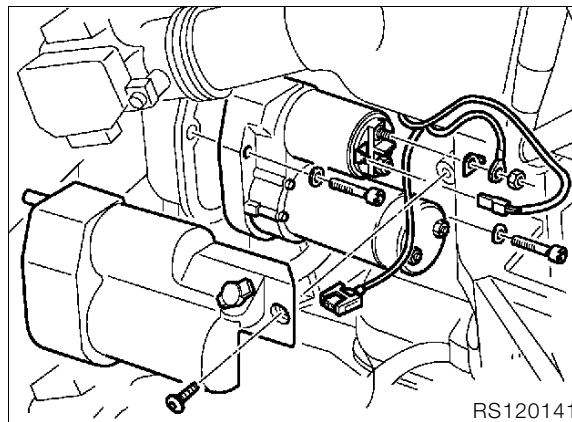

RS120141

- **[RS/GS/RT]** Detach starter-motor cover/pull off socket cable.
- Detach leads on starter motor/remove starter motor.



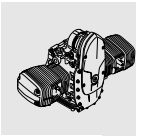
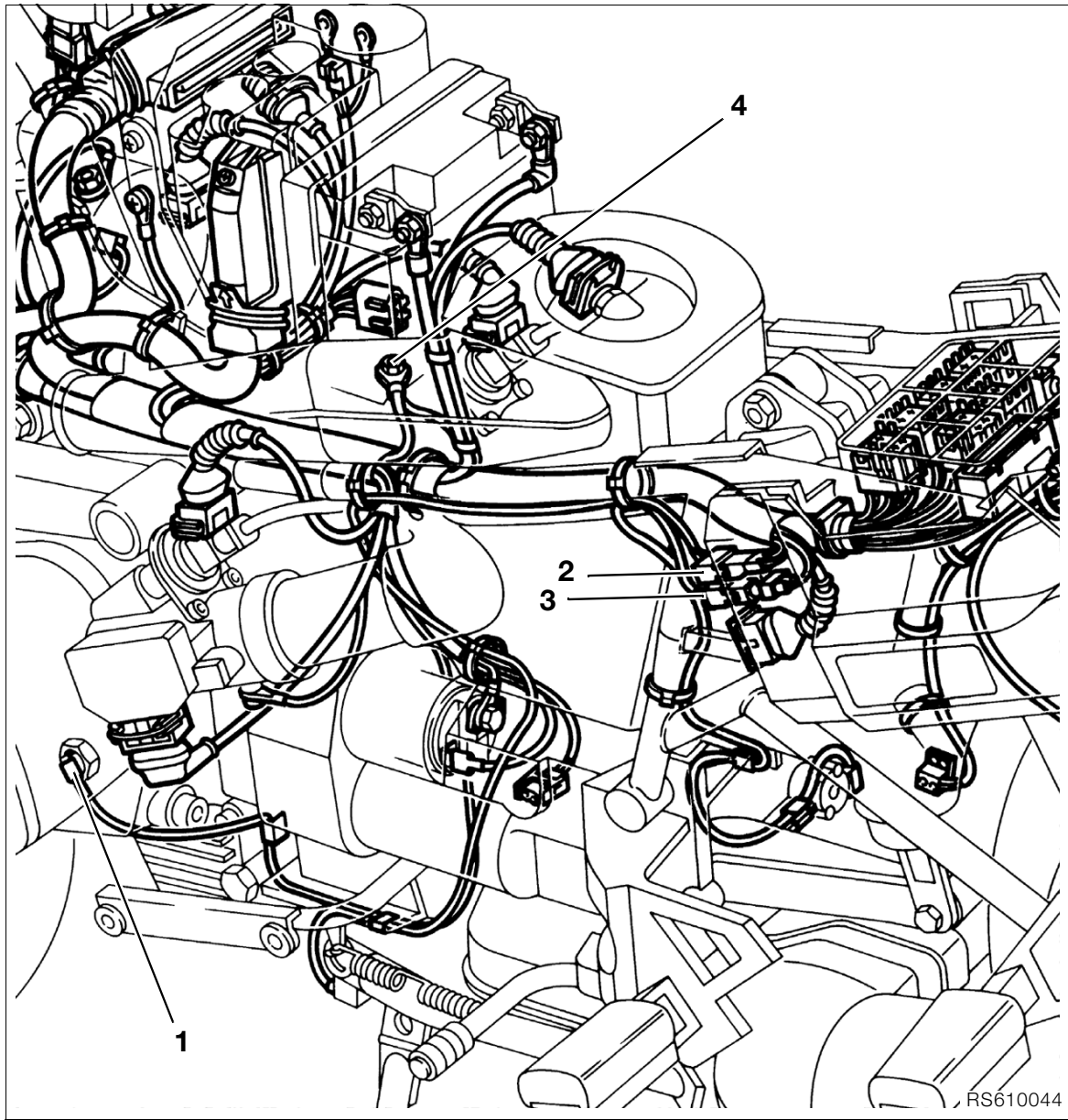

- Disconnect oil pressure switch (1).
- Separate plug connection for side stand switch (2).
- Separate plug connection for gearbox neutral-indicator switch (3).
- Detach ground (earth) strap (4).

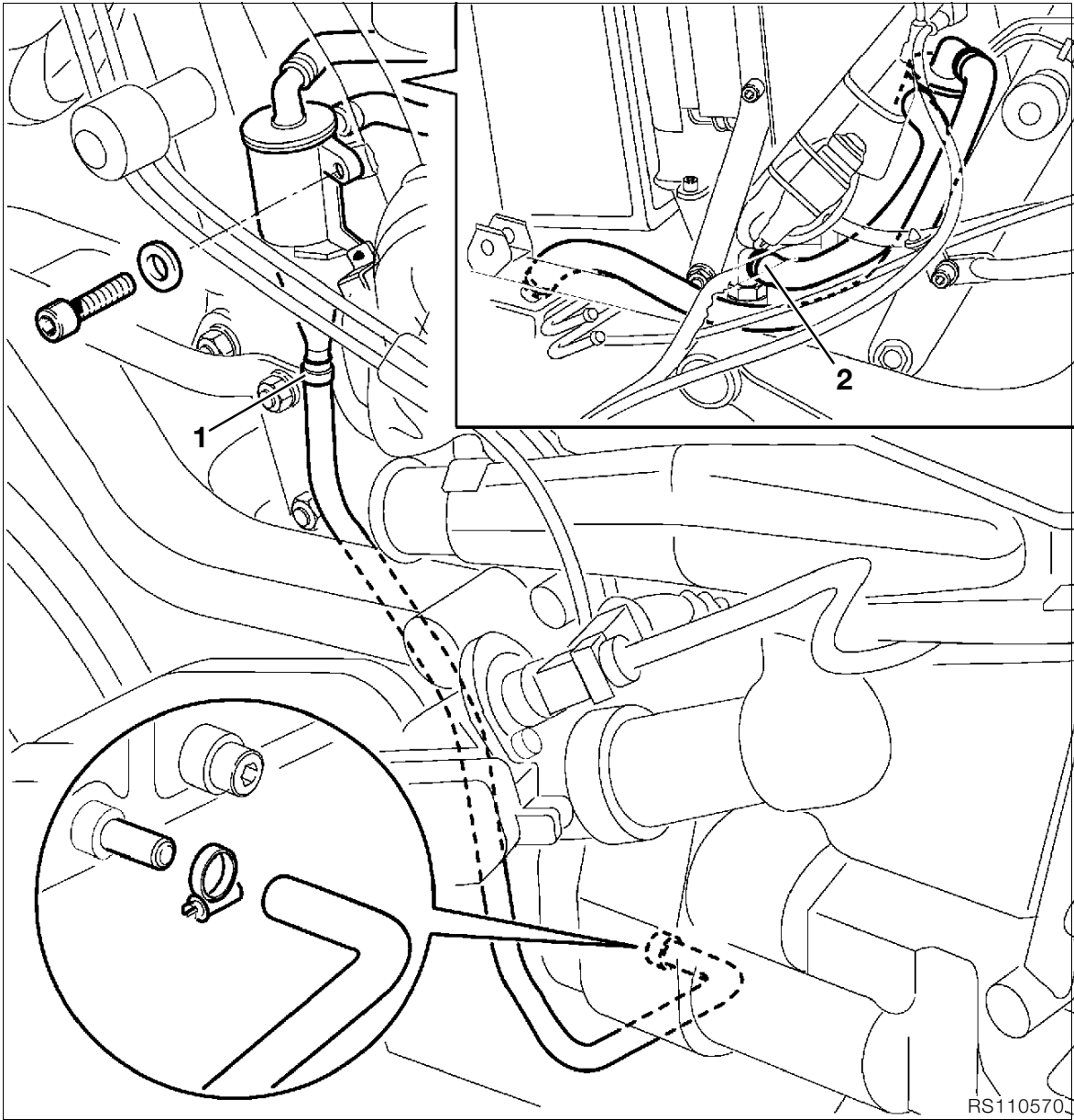
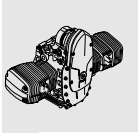

- **[RS]** (Version without rotary breather) Detach oil return line at oil trap (1).
- Detach engine breather pipe from engine (2)

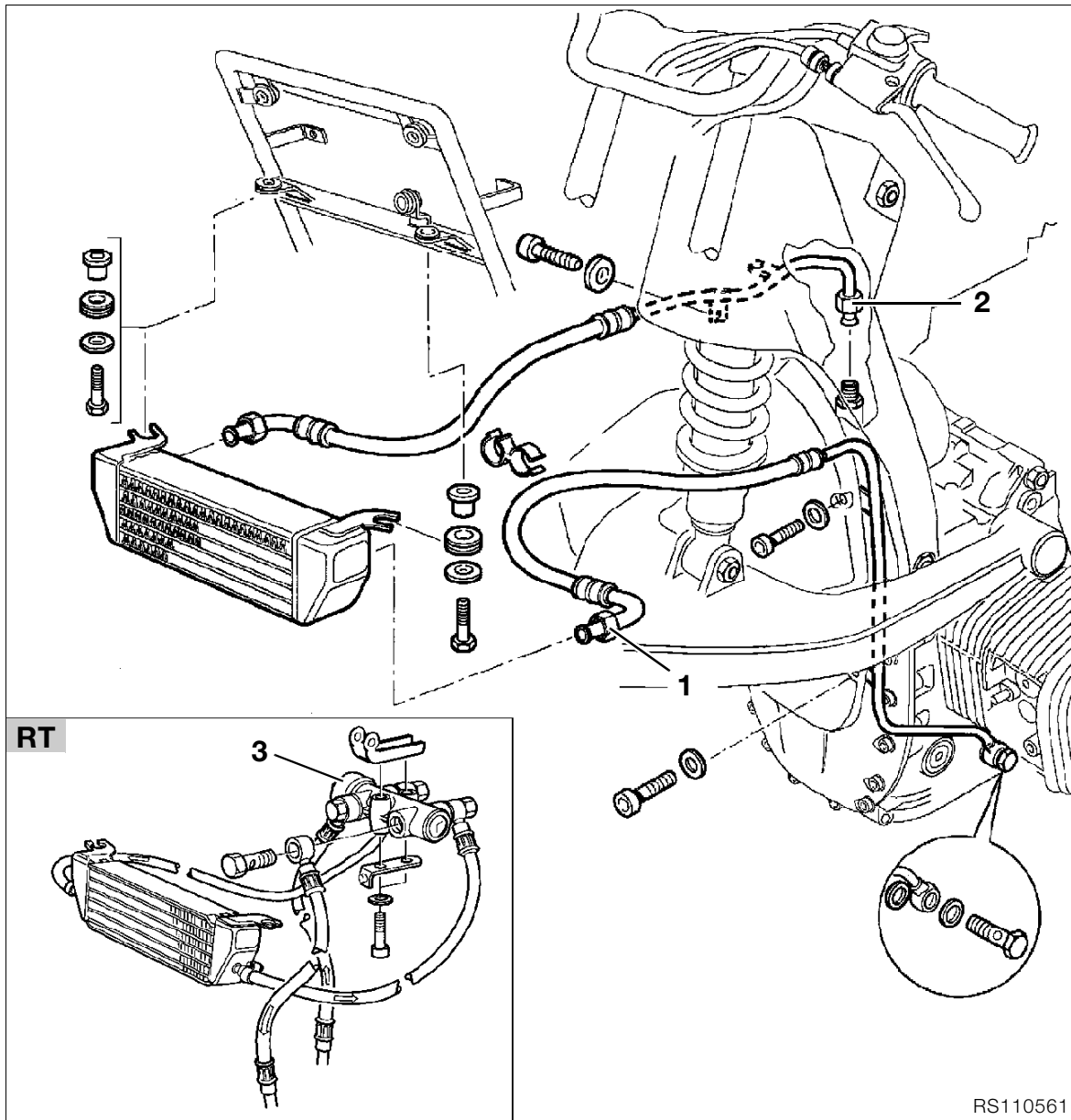

- Detach oil cooler pipe (1) at left of oil cooler.
- **[RT]** Detach oil cooler line at oil thermostat (3).
- Detach right oil cooler line from engine (2).
- **[R]** Detach oil cooler holder and remove together with oil cooler.
- Unscrew hose clips/throttle stub pipe and insert stub pipe into air cleaner box.
- Remove rear brake caliper/tie up to rear frame with cable strap.
- **[ABS]/[GS/R/RT]** Detach ABS sensor.
- Disconnect clutch cable.

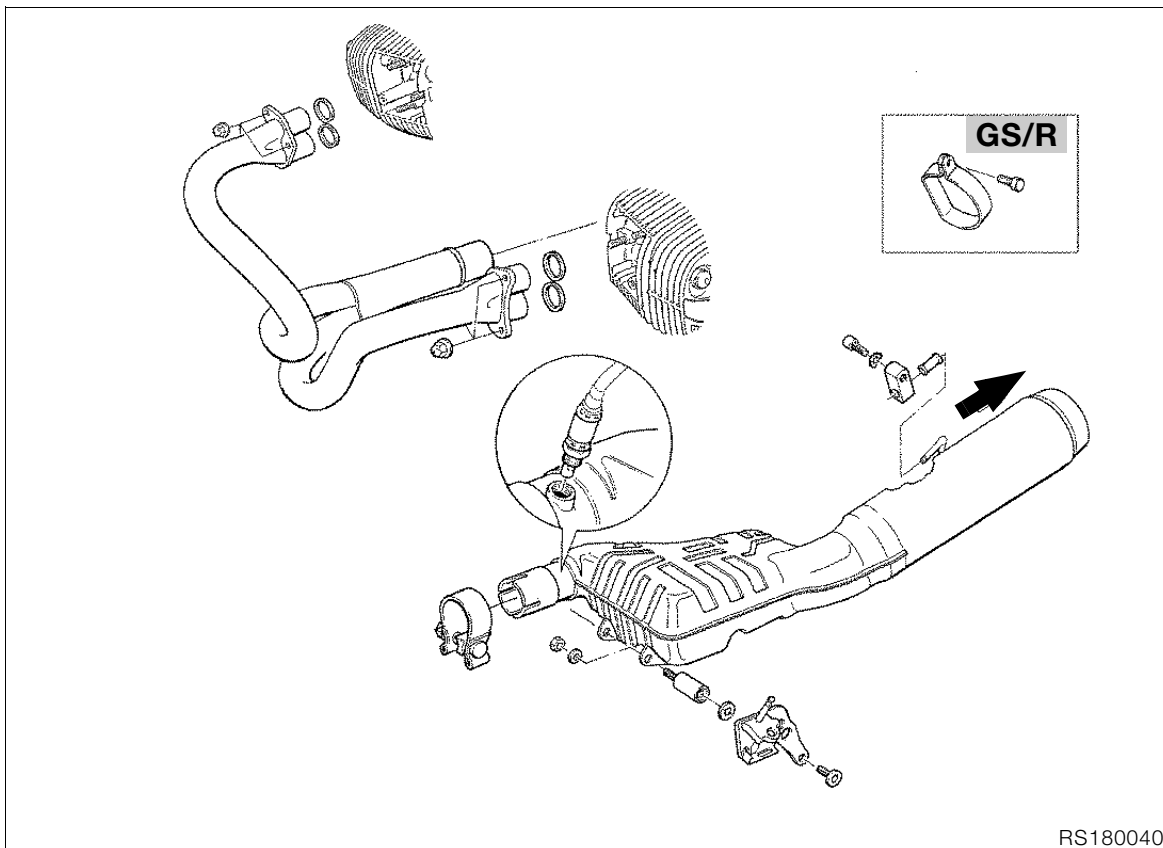
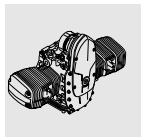

- Remove muffler (silencer).
- Remove manifold pipes.



**Caution:**

Detach oxygen sensor cable - do not subject to tension.

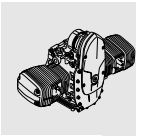
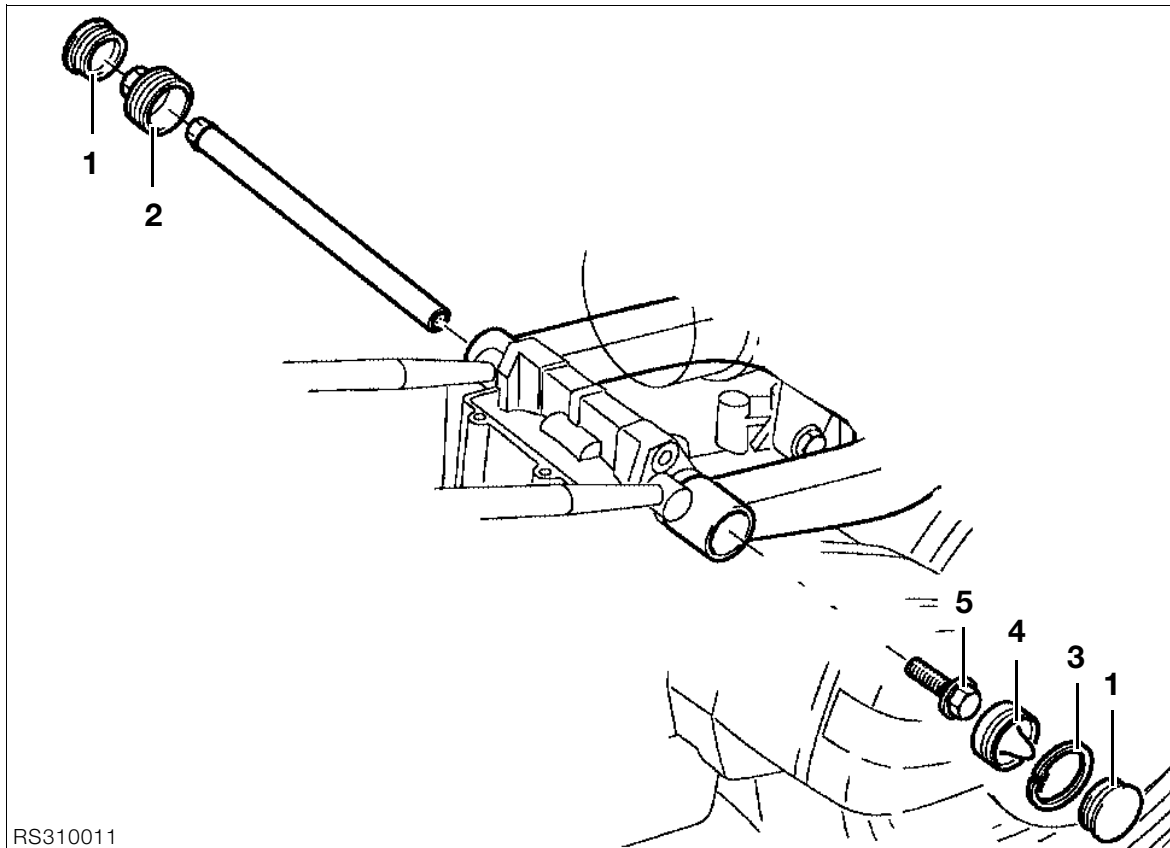

- Remove covers (1) on leading link pivots.
- Unfasten left screw cap (2).
- Remove right retaining ring (3).
- Remove retaining cap (4).
- Take out bolt (5) at right.

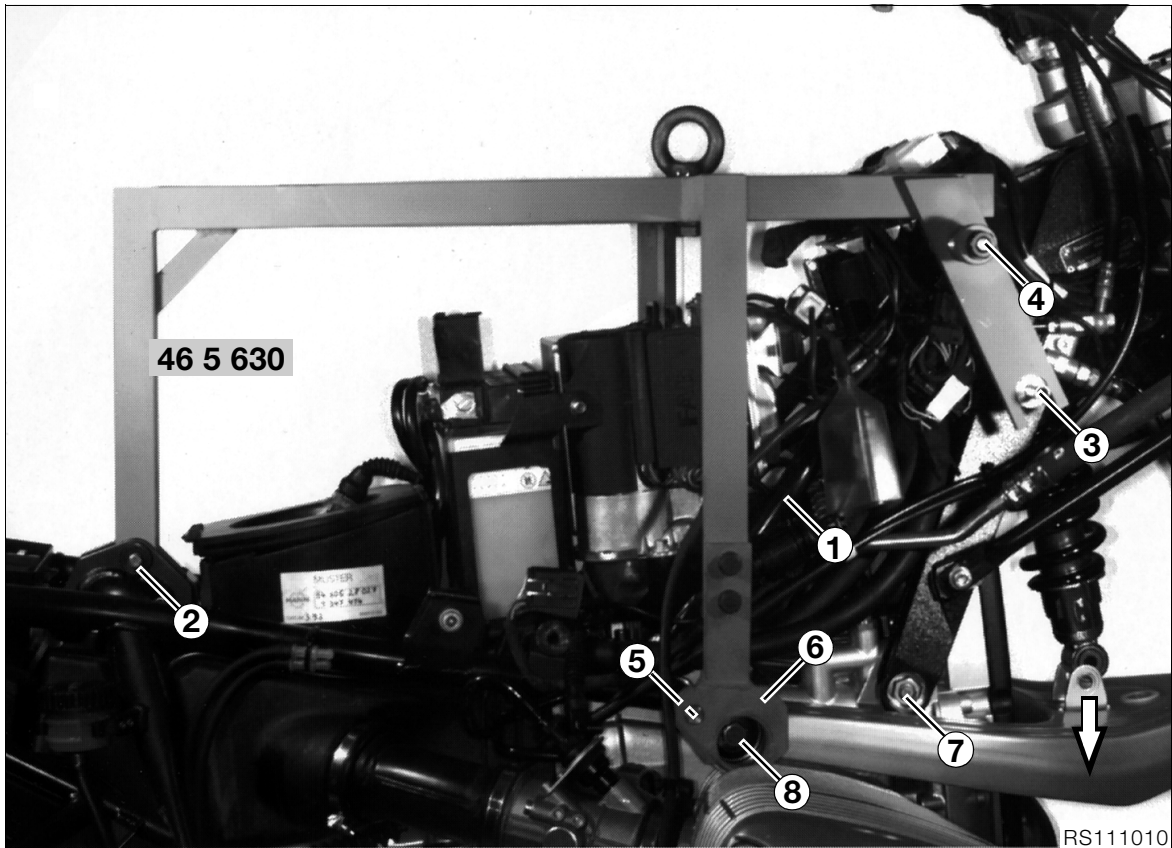
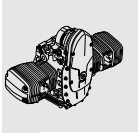

#### Fitting auxiliary frame

- Remove the rear wheel.
- Remove rear suspension strut.
- Install the rear wheel.
- Remove upper retaining screw and lower pin in connecting struts (1) between engine and frame.
- Attach auxiliary frame, **BMW No. 46 5 630**, at rear suspension strut pivot (2).
- Hook the auxiliary frame to the front tank mount (3).
- Center the auxiliary frame over the plane surface of the tank mount, insert threaded bushes (4) fully into the connecting struts/frame and tighten firmly.



#### Caution:

Protect tank mount with adhesive tape to prevent scratching.

- Unfasten rear frame screw connection (5) at front left/right.
- Insert adapter (6) into the leading link/rear frame mount and secure it to the auxiliary frame.
- Unfasten lower front suspension strut mount.
- Press front of leading link down (arrow), or pull rear section downwards.
- Unscrew and remove pin (7) securing the frame to the engine.



#### Caution:

Protect tank mount with adhesive tape to prevent scratching.

- Secure front suspension strut at bottom.
- Detach rear left/right of rear frame.
- Detach left intake pipe at cylinder head and pull downwards.
- Withdraw leading link shaft (8) to the left.
- Raise frame assembly at the front.

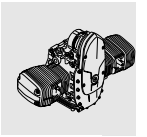
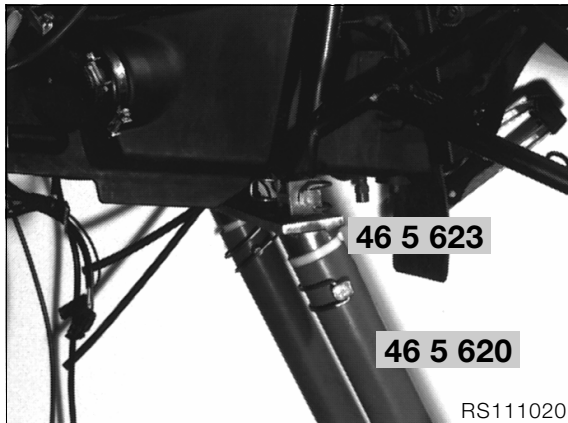

- Attach frame support, **BMW No. 46 5 620**, with adapter, **BMW No. 46 5 623**, to the frame unit.
- Remove gearbox/swinging arm/rear axle/rear wheel together.

**Take off auxiliary frame.**

- Lower frame assembly at the front.



**Caution:**

Ensure that all components are correctly located. Do not damage electrical wiring, leads or wire cables.

- Detach left intake pipe at cylinder head and pull downwards.
- Apply a light coating of grease to the leading link shaft, insert from the left and secure tightly.
- Unfasten lower front suspension strut mount.
- Press front of leading link downwards or pull rear section downwards.
- Using mandrel, **BMW No. 46 5 630**, align the front frame bores with the engine bore from the left, insert the pin from the right and screw up tightly.



**Caution:**

Do not scratch leading link - apply adhesive masking tape if necessary.

- Secure front suspension strut at bottom.
- Remove auxiliary frame.

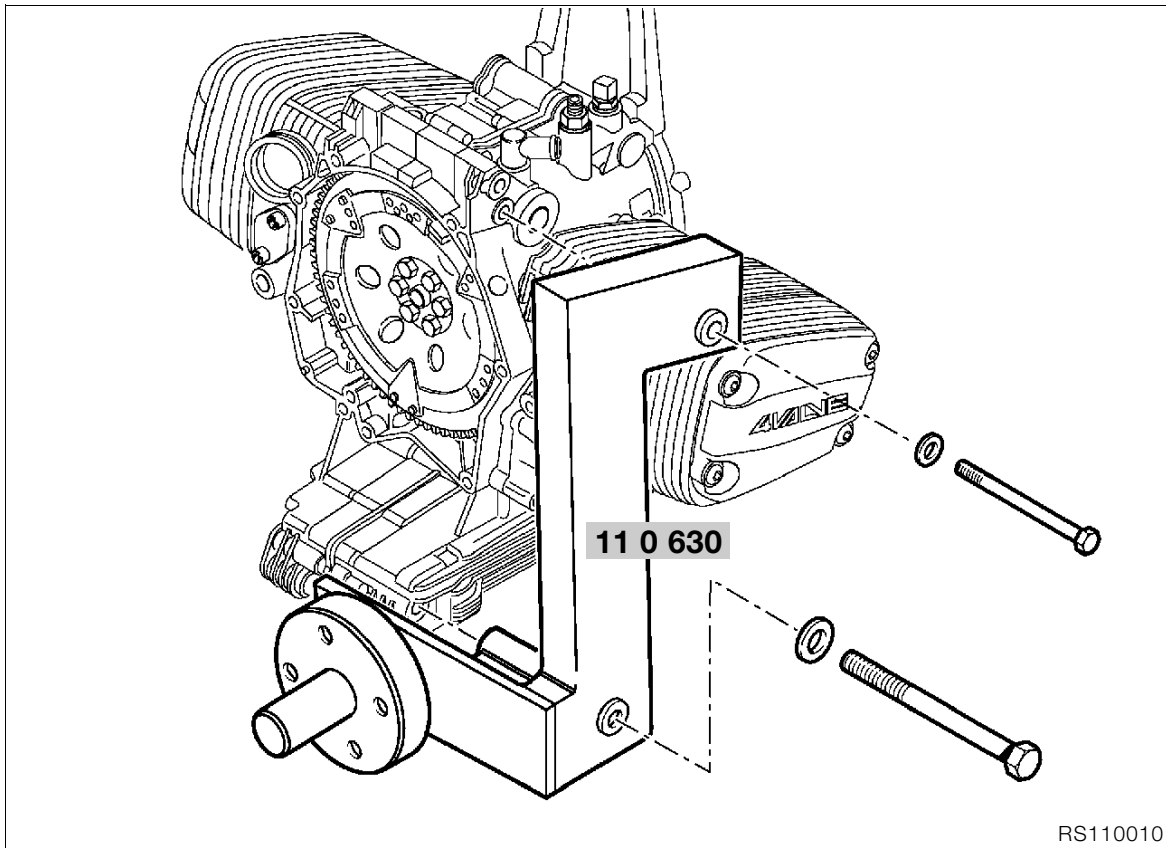
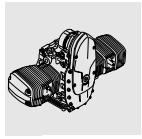

### Dismantling engine

- Attach engine mount, **BMW No. 11 0 630**, to engine block.
- Transfer engine to assembly frame.

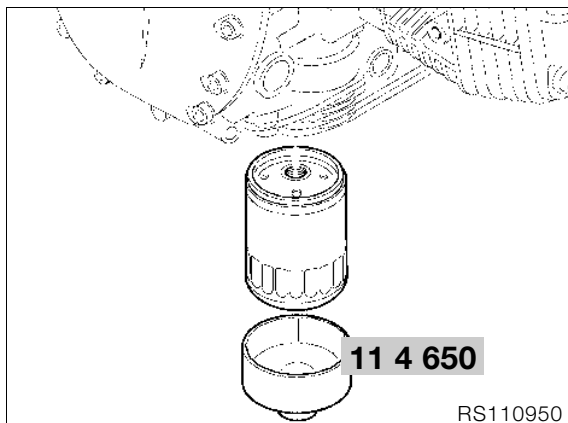

- Drain engine oil.
- Remove oil filter, using oil filter wrench, **BMW No. 11 4 650**.



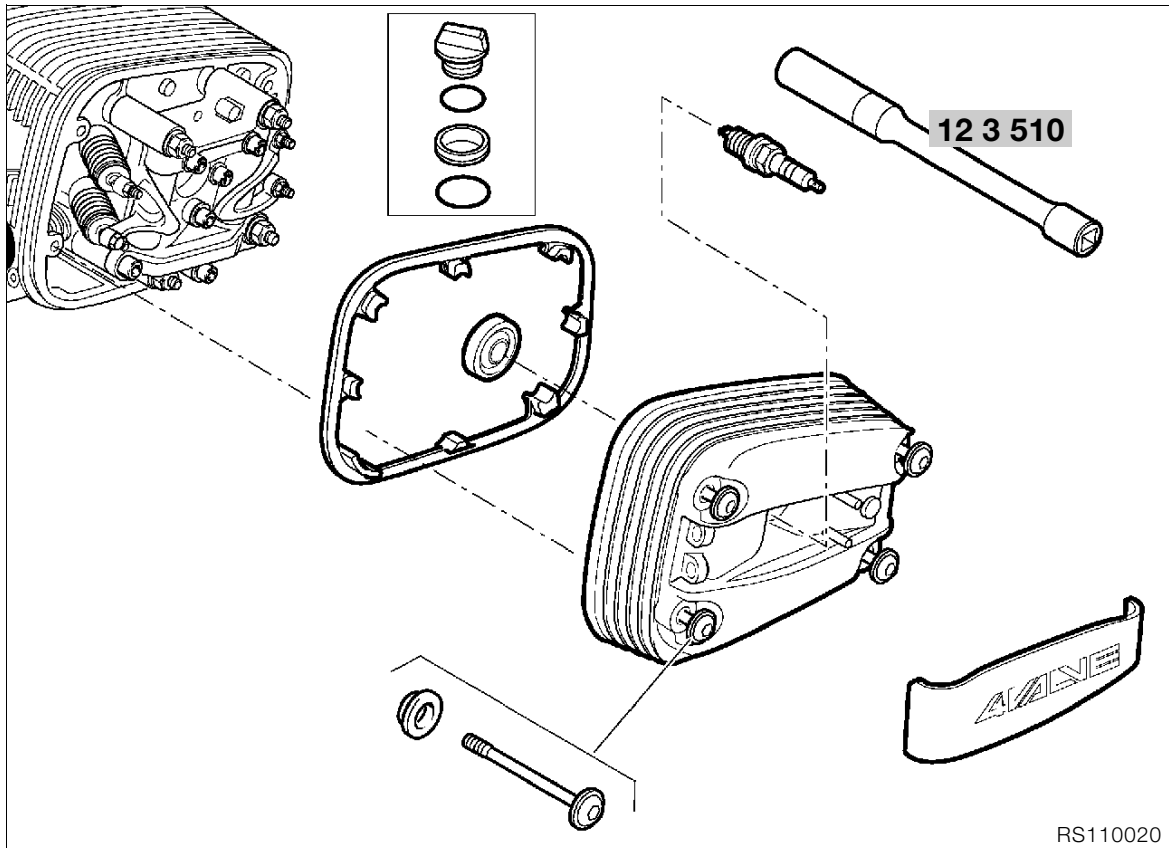

### Removing cylinder head cover

- Unscrew and remove spark plugs with spark plug wrench, **BMW No. 12 3 510**.
- Remove cylinder head cover.



**Caution:**  
Trap escaping oil.

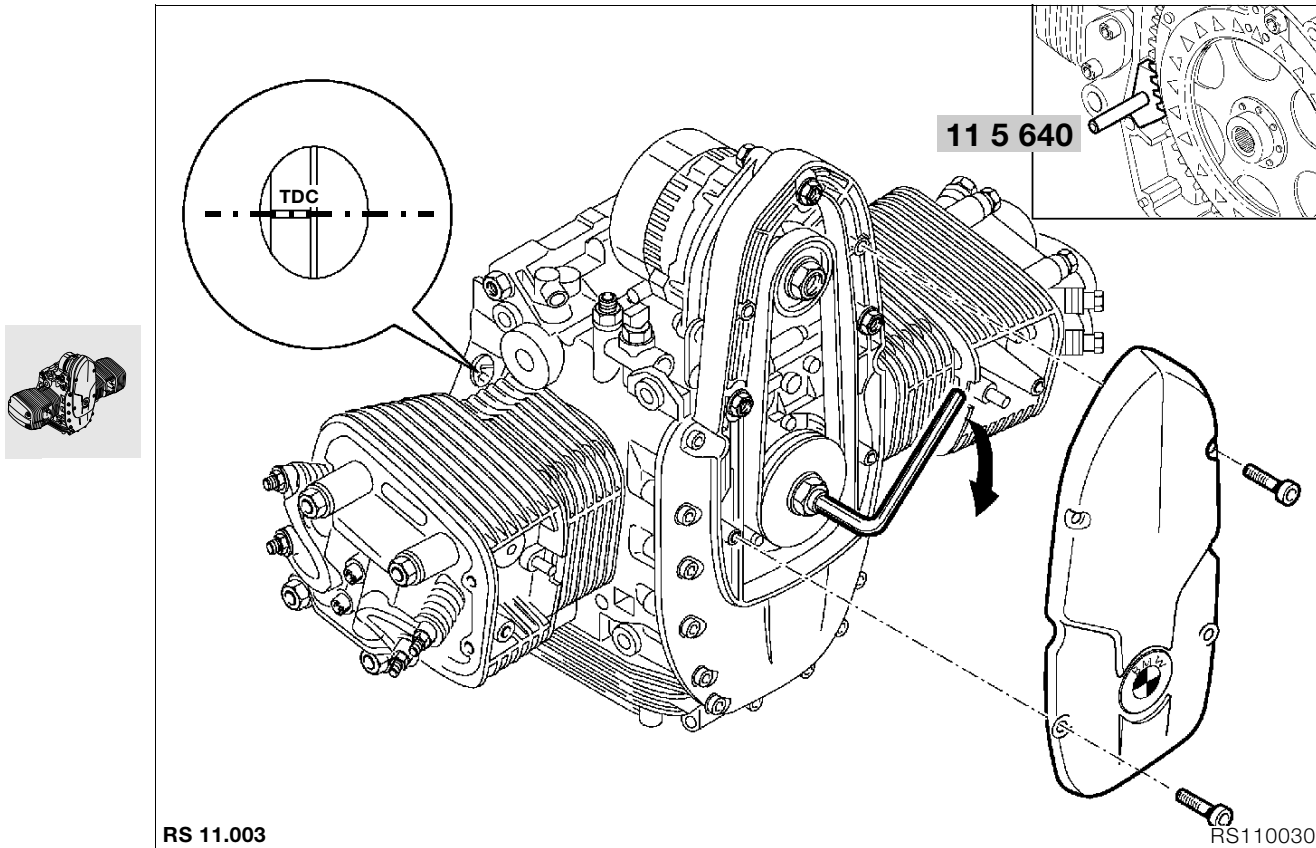

### Locking the engine in the TDC position

- Remove front cover.
- Turn the belt pulley to move the piston to TDC on the ignition stroke.

#### TDC on ignition stroke:

1. TDC mark is visible, and
  2. the inlet and exhaust valves in the cylinder in question are closed.
- Secure the clutch housing with locking device, **BMW No. 11 5 640**.

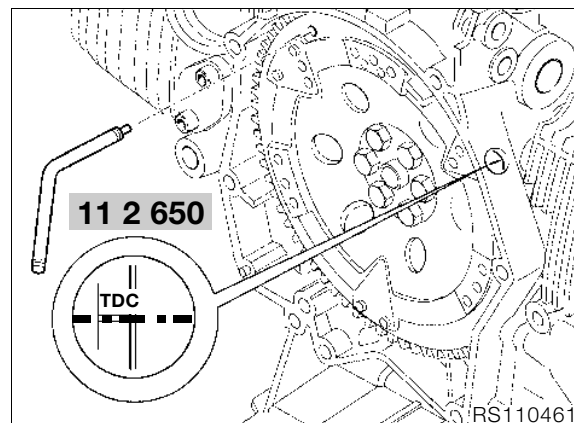

#### Note:

The engine can be set to top dead center with the TDC pin, **BMW No. 11 2 650**, which is inserted into the clutch housing and the engine block at TDC.

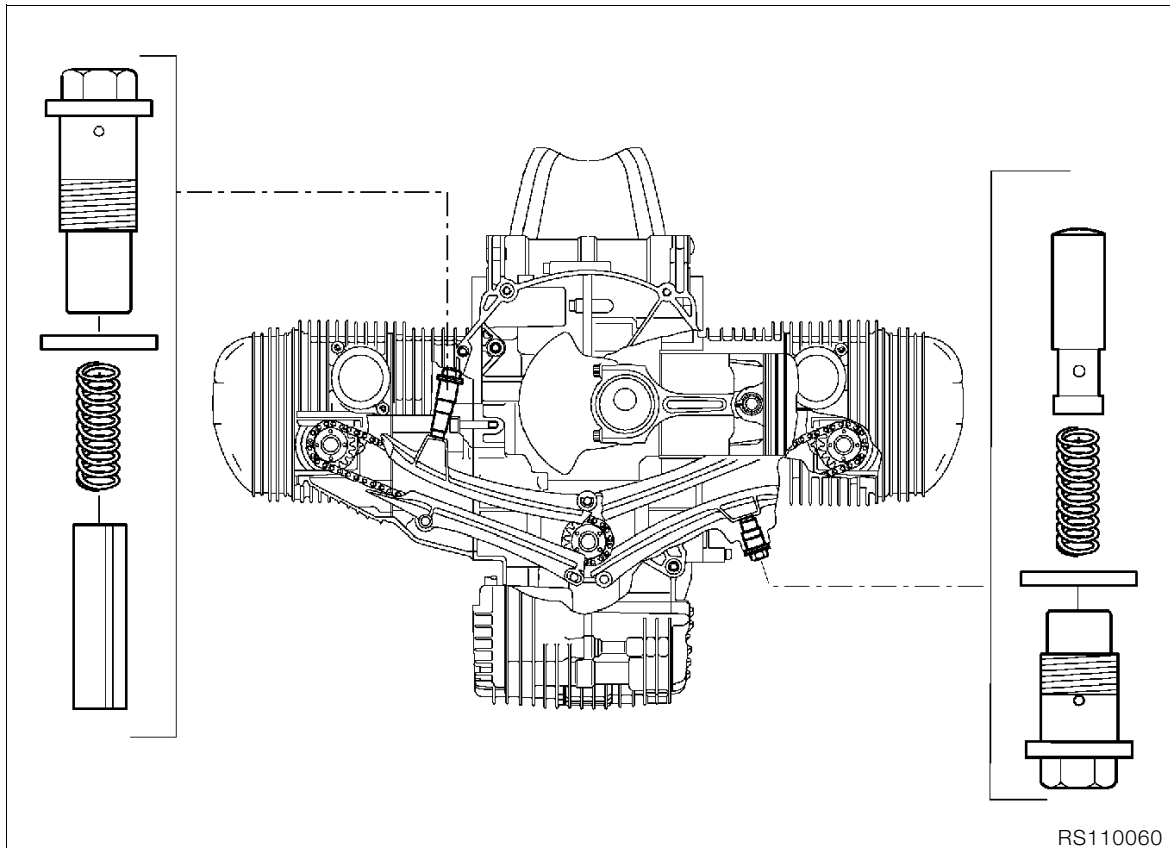

## Removing and installing chain tensioner



### Caution:

Do not accidentally confuse the chain tensioner pistons. When installing, fit a new gasket.

### Assembly specification for timing chain tensioner:

#### Removal:

- Remove timing chain tensioner, then remove cam-shaft sprocket from camshaft.

#### Installation:

- First install camshaft sprocket, then timing chain tensioner.



### Caution:

Failure to observe this sequence can cause the chain tensioner piston to fall into the left side of the timing chain cavity.



### Tightening torque:

Chain tensioner ..... 32 Nm

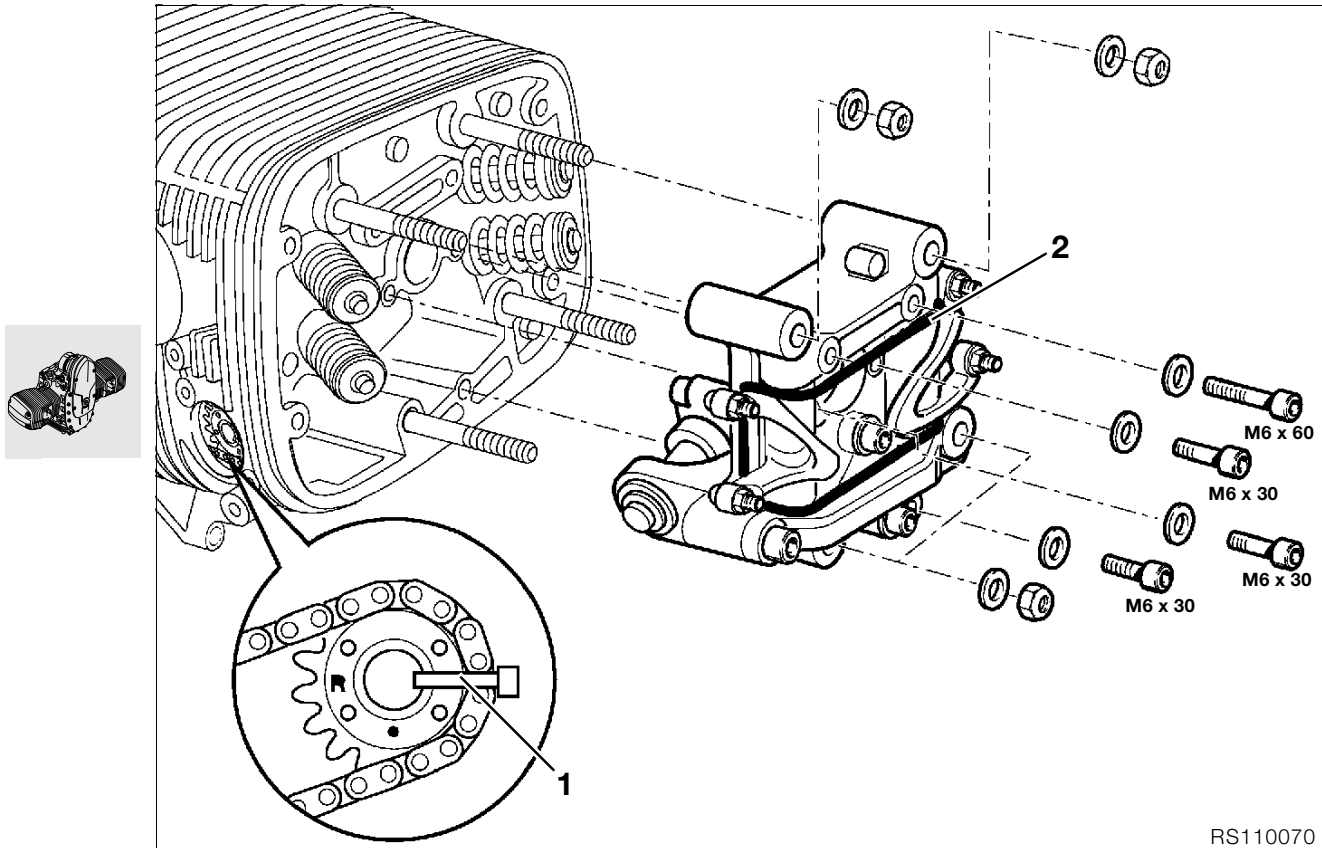

RS110070

### Removing valve gear holder

- Remove valve gear holder.
- Secure rockers with a rubber band (2).

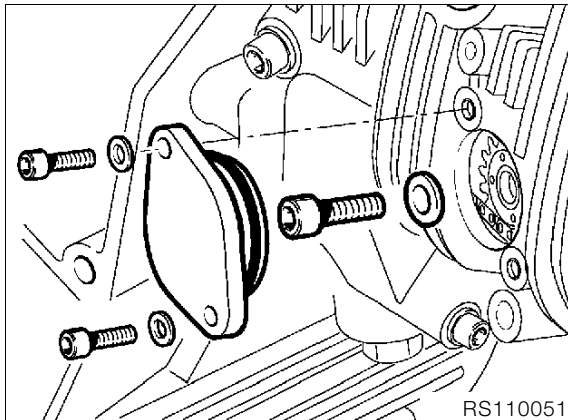

RS110051

- Remove camshaft sprocket cover.
- Unscrew/press off camshaft sprocket.



**Note:**

If the camshaft sprocket (1) is not removed after loosening, it must be held firmly and prevented from falling into the engine block (e.g. with a cable strap).



**Note:**

If no work is carried out on the valve gear holder, remove it together with the cylinder head.

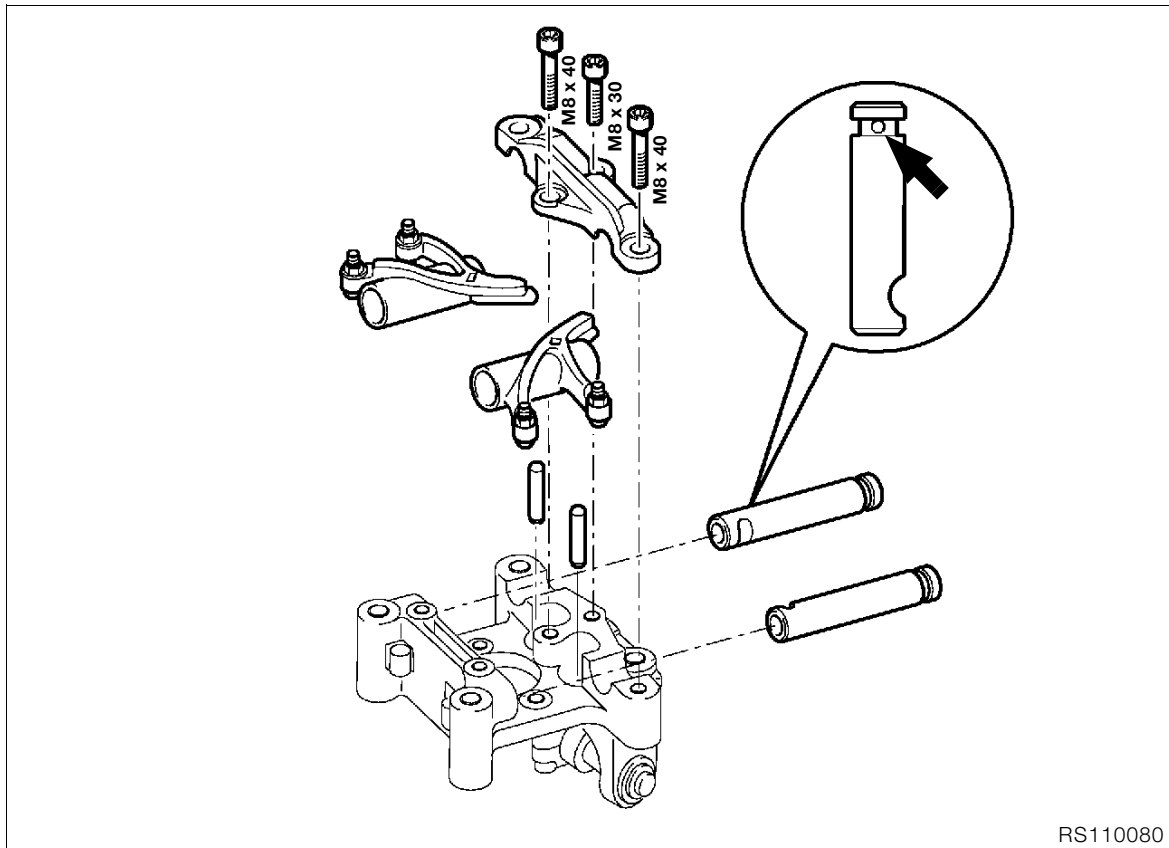

### Dismantling/reassembling valve gear holder

- Remove bearing cap.
- Insert a suitable drift into the bore (arrow) of the rocker shaft, and pull the shaft out of the mount by twisting it in both directions.
- Remove pushrods.



**Caution:**

Do not accidentally confuse rocker shafts and pushrods.

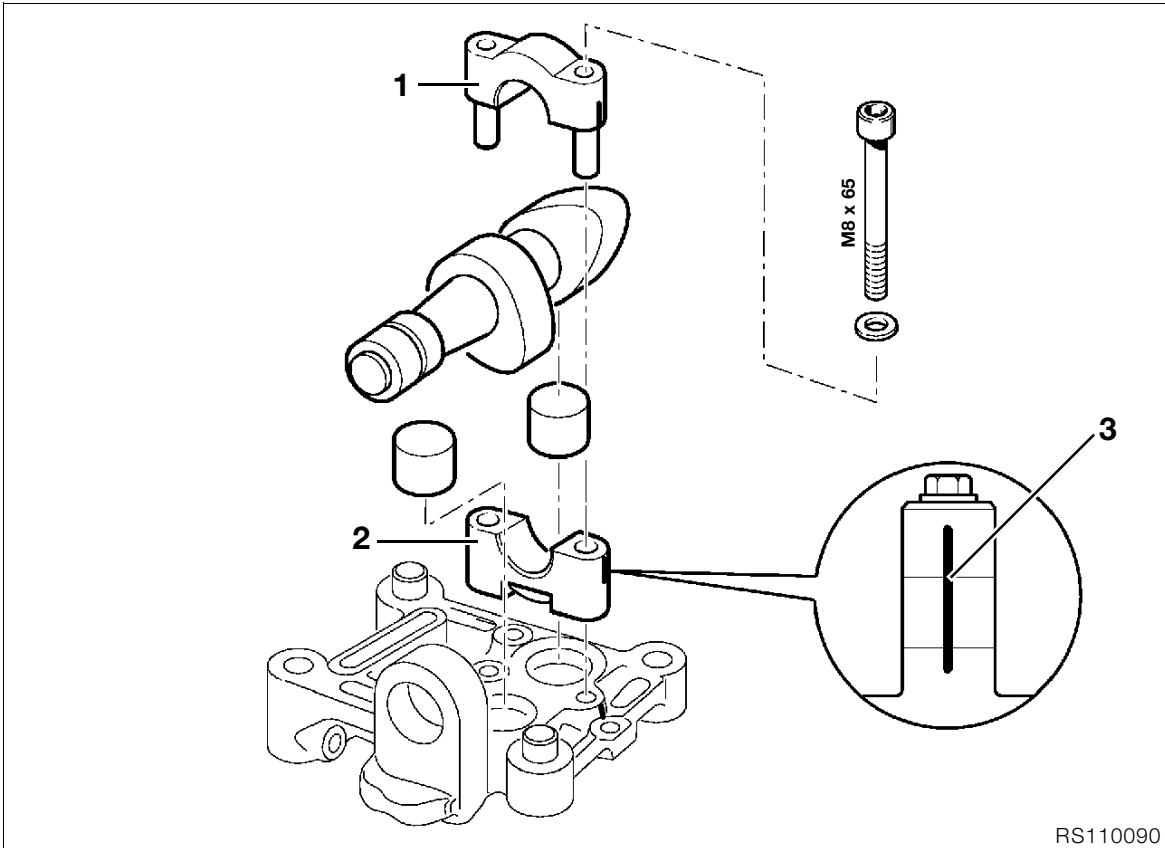
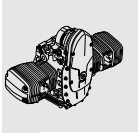

RS110090

- Remove camshaft bearing cap (1).
- Remove camshaft and bearings (2).
- Remove bucket-type tappets.



**Caution:**

Do not accidentally confuse the bucket-type tappets.

- Reassemble in the reverse order of work.



**Caution:**

Note direction of installation (3) for camshaft bearing cap. The cutout on the rocker shafts must be aligned with the retaining holes.



**Note:**

Locate pushrods in ball cups on rockers and hold the rockers together with a rubber band to secure the pushrods in position.

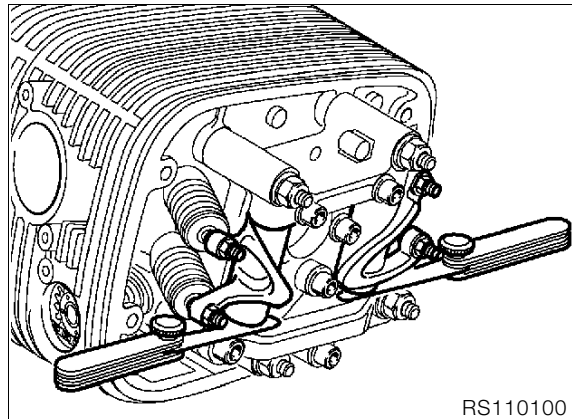

RS110100

- Reposition the bearings until minimum endplay is obtained.

**End float of rocker:**

min..... 0.05 mm (0.00197 in)  
 max..... 0.40 mm (0.01575 in)



**Tightening torque:**

M 8 screw in rocker shaft bearing cap ..... 15 Nm  
 M 8 screw for camshaft bearing cap ..... 15 Nm

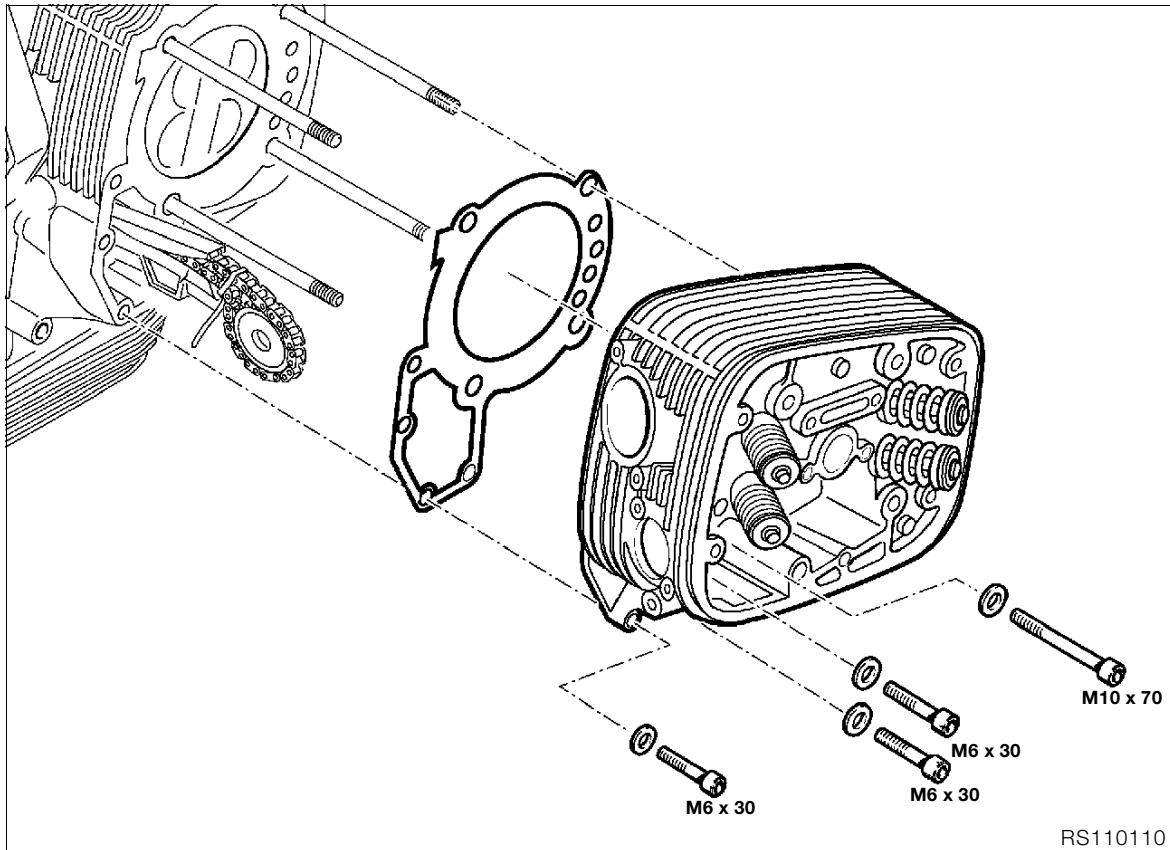

Removing cylinder head

RS110110

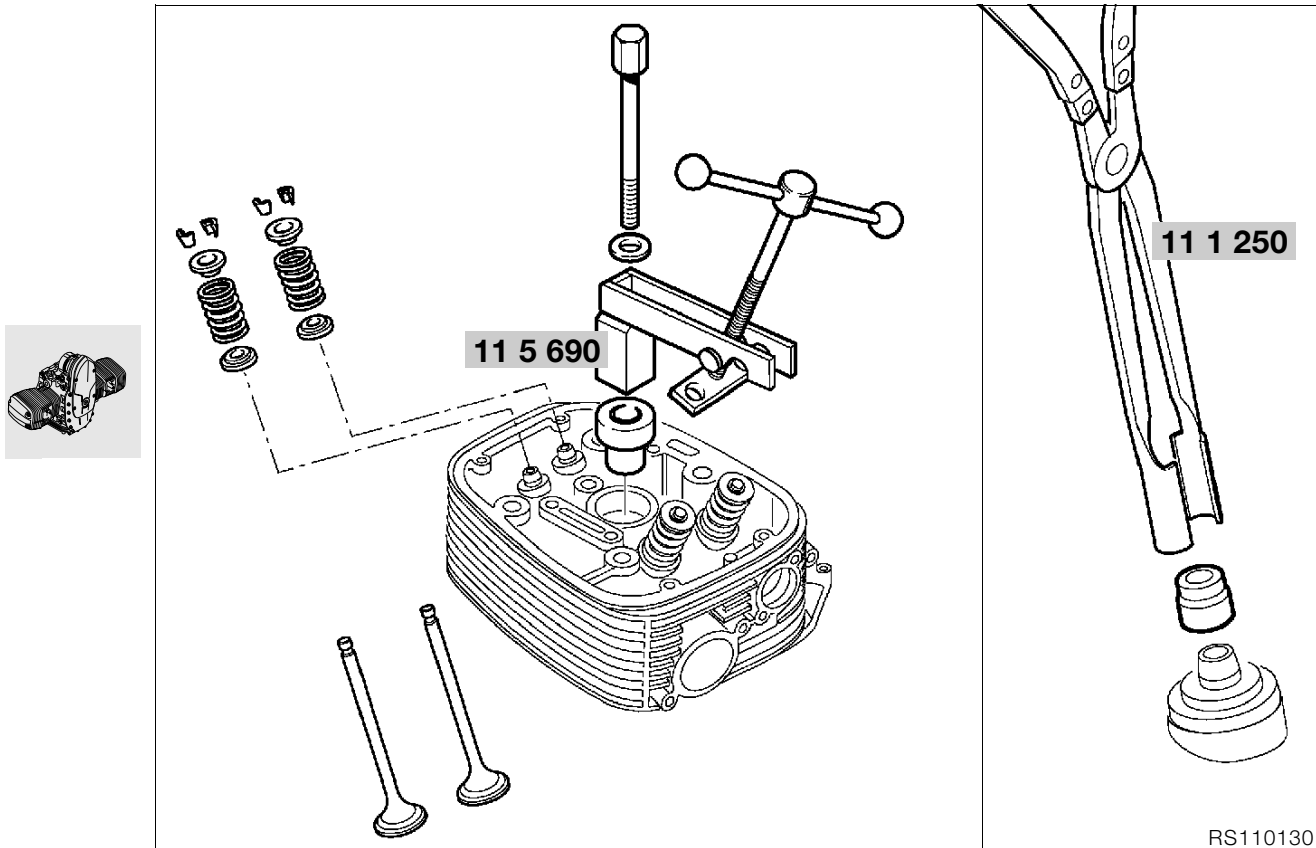

Dismantling, checking, repairing and re-assembling cylinder head

#### Removing and installing valves



#### Caution:

Do not scratch sealing face on cylinder head. Place the head on a clean, scratch-free surface.

- Attach valve spring tensioner, **BMW No. 11 5 690**, to cylinder head.
- Clamp the valve springs.
- Separate valve collet from spring plate by striking the valve head gently.
- Remove valve collet sections.
- Relieve tension on valve springs.
- Remove top/bottom spring plates, valve springs and valves

#### Removing valve stem seals

- Pull off valve stem seal with pliers, **BMW No. 11 1 250**.



#### Note:

If a valve is removed, the valve stem seal must be renewed.



### Checking valves for wear

- Clean combustion residue from valves.
  - Check valve dimensions.
- ⇒ See Technical Data.

### Remachining valve seat

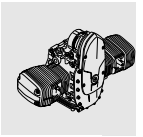
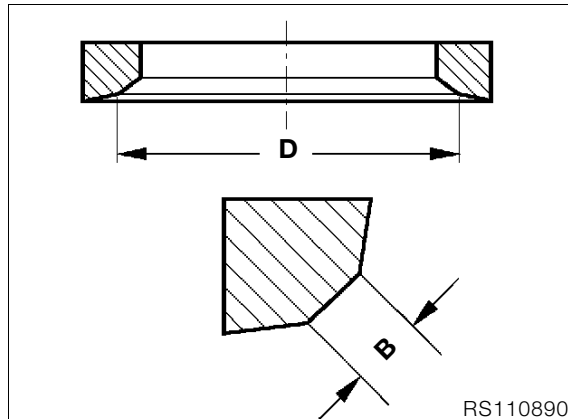

#### Caution:

Width (B) and diameter (D) must always be maintained when remachining the valve seat.

⇒ See Technical Data.

### Checking and repairing cylinder head

- Remove combustion residues from combustion chamber.
- Check sealing face for damage/distortion, and skim flat if necessary.

#### Skimming sealing face:

.....max. 0.2 mm (0.00787 in) metal re-moval

### Checking valve guide for wear

- Check valve guide bore.
- ⇒ See Technical Data.

### Replacing valve guides

- Heat cylinder head slowly and uniformly to 200 °C in a suitable oven.



#### Caution:

Wear protective gloves when handling heated parts.

- Drive out valve guides with 6/5 mm (0.236/0.197 in) dia. extractor pin, **BMW No. 11 5 672/674**, from the combustion chamber side.
- Allow cylinder head to cool down to room temperature (app. 20 °C).
- Examine valve guide bore for:
  - wear,
  - widening taper and
  - correct dimensions in H7 tolerance range (12.500...12.518 mm)(0.4921...0.4928 in).

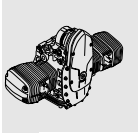

#### Note:

Valve guides are installed in the cylinder head with an interference fit of 0.015...0.044 mm (0.00059...0.00173 in).

### If valve guide bore is undamaged and dimensions are within correct 12.5 H7 tolerance range:

- Use original 12.5 U6 (12.533...12.544 mm) (0.4934...0.4939 in) valve guide.
- Measure valve guides with micrometer.

### If valve guide bore is undamaged but slightly larger than the 12.5 H7 tolerance range:

- Use replacement valve guide 12.550...12.561 mm (0.4941...0.4945 in).

### If valve guide bore is damaged or not to correct dimensions in 12.5 H7 tolerance range:

- Use an oversize 12.7U6 (12.733...12.744 mm) (0.5013...0.5017 in) valve guide.

#### Repair method 1 – ream out the bore

(if bore is damaged or not to correct dimensions)

- Determine actual diameter of valve guide using micrometer.
- Open out bore with Ø12.7 H7 mm (12.700...12.718 mm) (0.5...0.50071 in) reamer.

#### Repair method 2 – lathe-turn the valve guide (bore must not be damaged)

- Determine actual diameter of bore with internal measuring tool.
- Calculate the nominal diameter of the valve guide:

Nominal diameter of valve guide = bore dia. + interference-fit value (0.015...0.044 mm) (0.00059...0.00173 in).

- Use an oversize 12.7 U6 (12.733...12.744 mm) (0.5013...0.5017 in) valve guide.
- Turn down oversize valve guide to nominal dimension.
- Slowly heat cylinder head to 200 °C in a suitable oven.
- Immerse valve guide in liquid grinding paste.
- Freeze valve guide with dry ice..



#### Caution:

Immediately before pressing in, the temperature must be -40 °C.

- Place heated cylinder head flat on workbench or a similar surface.
- Attach chilled valve guide to 6/5 mm (0.236/0.197 in) dia. pressing-in arbor **BMW No. 11 5 671/673**.
- Insert valve guides into cylinder head with no delay.
- Allow cylinder head to cool down to room temperature, app. 20 °C.
- Inspect bore in valve guide.



#### Note:

Valve guides for repair purposes have an internal diameter of 6.01 H7 mm (5.01 H7 mm/R 850). In most cases, the bore after pressing in the valve guide is in the 6.00 H7 mm (5.00 H7 mm/R 850) tolerance range.

If the bore is too narrow, it should be opened out.

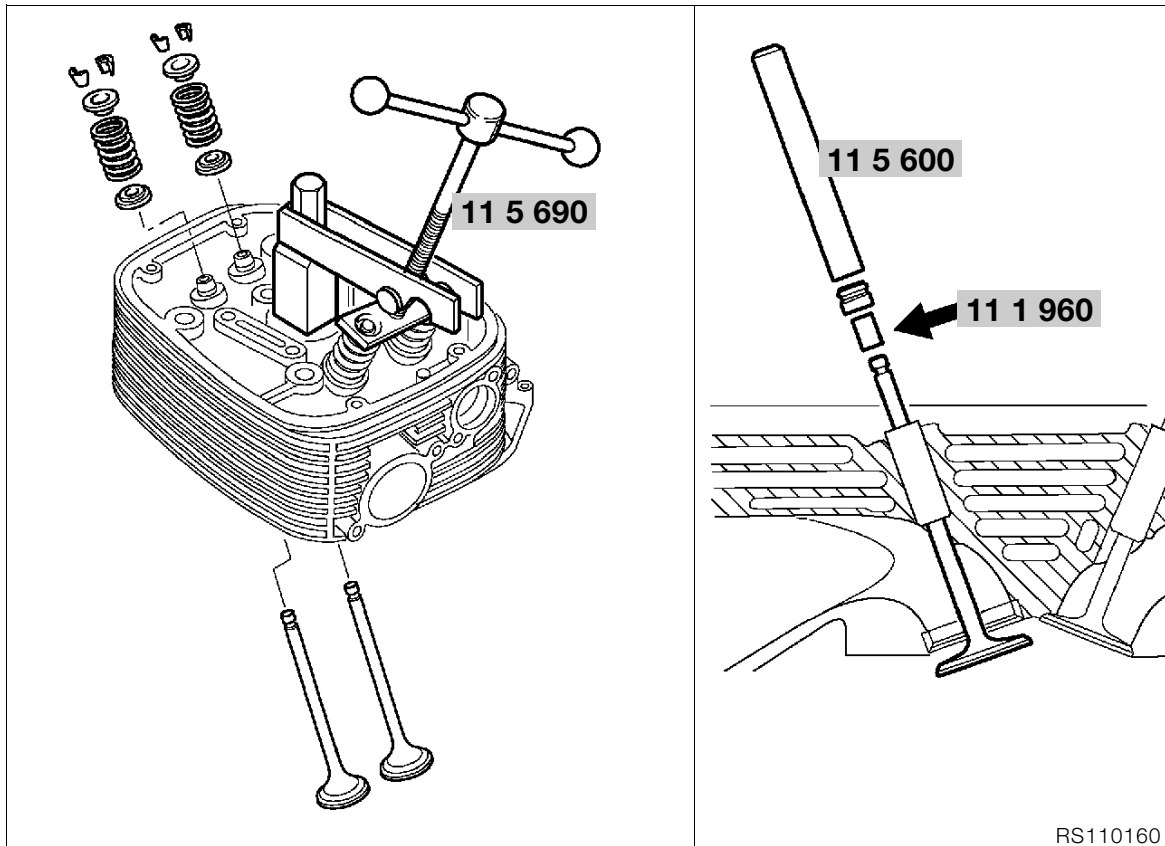

RS110160

#### Installing valve and valve stem seal



##### Note:

If a valve was removed, the valve stem seal must be renewed.

- Oil the stem when installing the valve.
- Push the 6 mm (0.236 in) dia. assembly sleeve (arrow), **BMW No. 11 1 960**, on to the valve stem.
- On 5 mm (0.197 in) dia. valve stems, shrink a short section of shrink-fit tube on the end of the valve stem.
- Install the valve stem seal with a 6/5 mm (0.236/0.197 in) dia. drift, **BMW No. 11 5 601/602**.



##### Caution:

Remove the assembly sleeve and the shrink-fit tube.

- Fit lower spring plate, valve spring and upper spring plate.
- Compress the valve springs with the clamping tool, **BMW No. 11 5 690**



##### Note:

Insert the taper valve collets using grease (to simplify assembly).



##### Caution:

Ensure that valve collets are correctly seated in the valve stem grooves.

- Relieve tension on valve springs.
- Check valves for leakage (blow-by).

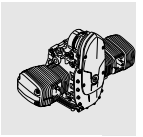

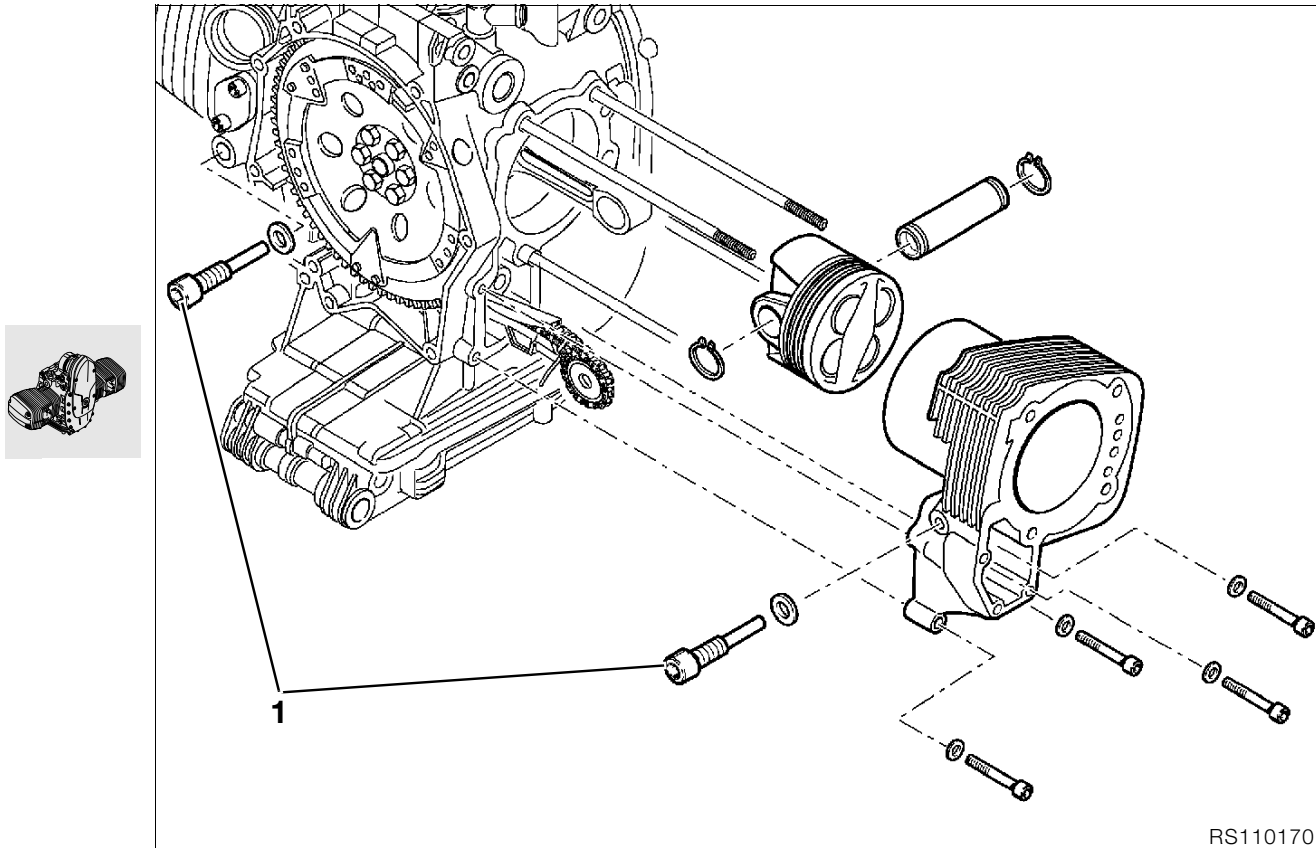

## Removing cylinder barrel

- Unscrew and remove guide rail bearing screw (1).
- Unscrew and remove cylinder retaining screws, and remove cylinder



### Caution:

When removing cylinder, ensure that the piston does not strike the engine block.

## Removing/dismantling piston

- Remove both retaining rings on piston pin.
- Press out piston pin by hand.
- Remove piston.
- Carefully remove piston rings with piston ring pliers.
- Remove carbonized oil from base of piston/clean the piston.



### Caution:

Do not accidentally confuse pistons, piston pins or piston rings.

## Checking pistons and cylinders

### Reference temperature

for measurements: .....20 °C.

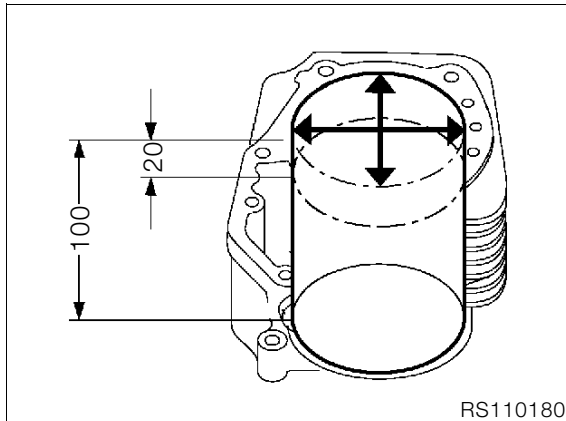

RS110180

- Measure cylinder bore with internal probe at 20 mm (0.787 in) and 100 mm (3.937 in) from the top in direction of piston pin, and again at a right angle to the first measurement.

➡ See Technical Data.

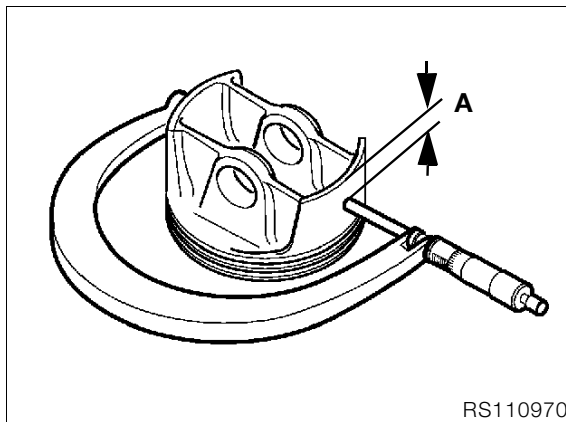

RS110970

**Measuring plane A :** ..... 6 mm (0.236 in)

➡ See Technical Data.

- Install piston rings in cylinder.

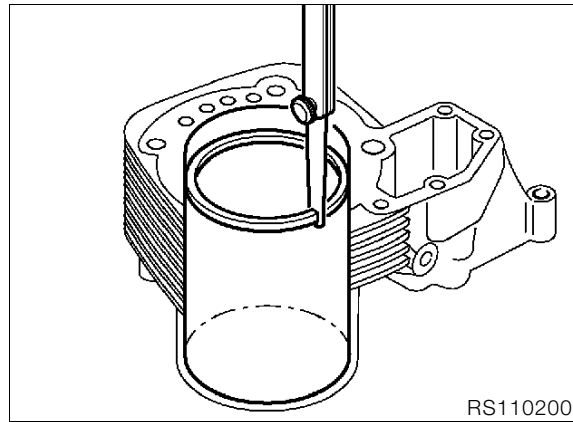

RS110200

- Determine piston ring clearance using feeler gauge.

➡ See Technical Data

## Assemble pistons

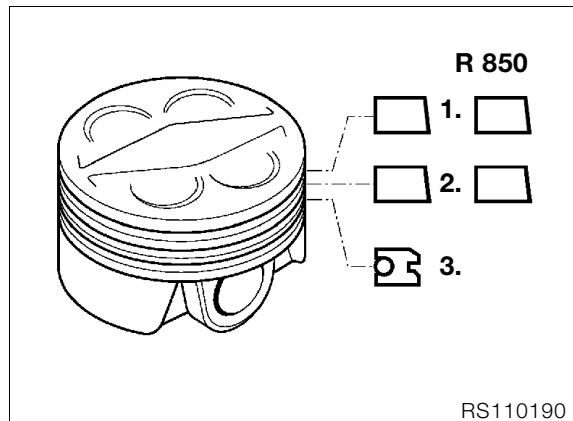

RS110190

- Carefully fit piston rings to piston in the following sequence, using piston ring pliers:
  - 3rd groove Equal-chamfer ring
  - 2nd groove Micro-taper compression ring
  - M-ring (R 850) m Ø TOP 4 DZ
  - 1st groove Micro-taper compression ring
  - B-ring (R 850) SPT TOP

- Determine top runout of piston rings.

➡ See Technical Data

### **⚠ Caution:**

The tubular-spring ring gap must be at 180° to the equal-chamfer ring gap.  
Install with the "Top" uppermost.

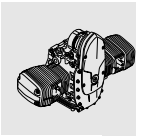

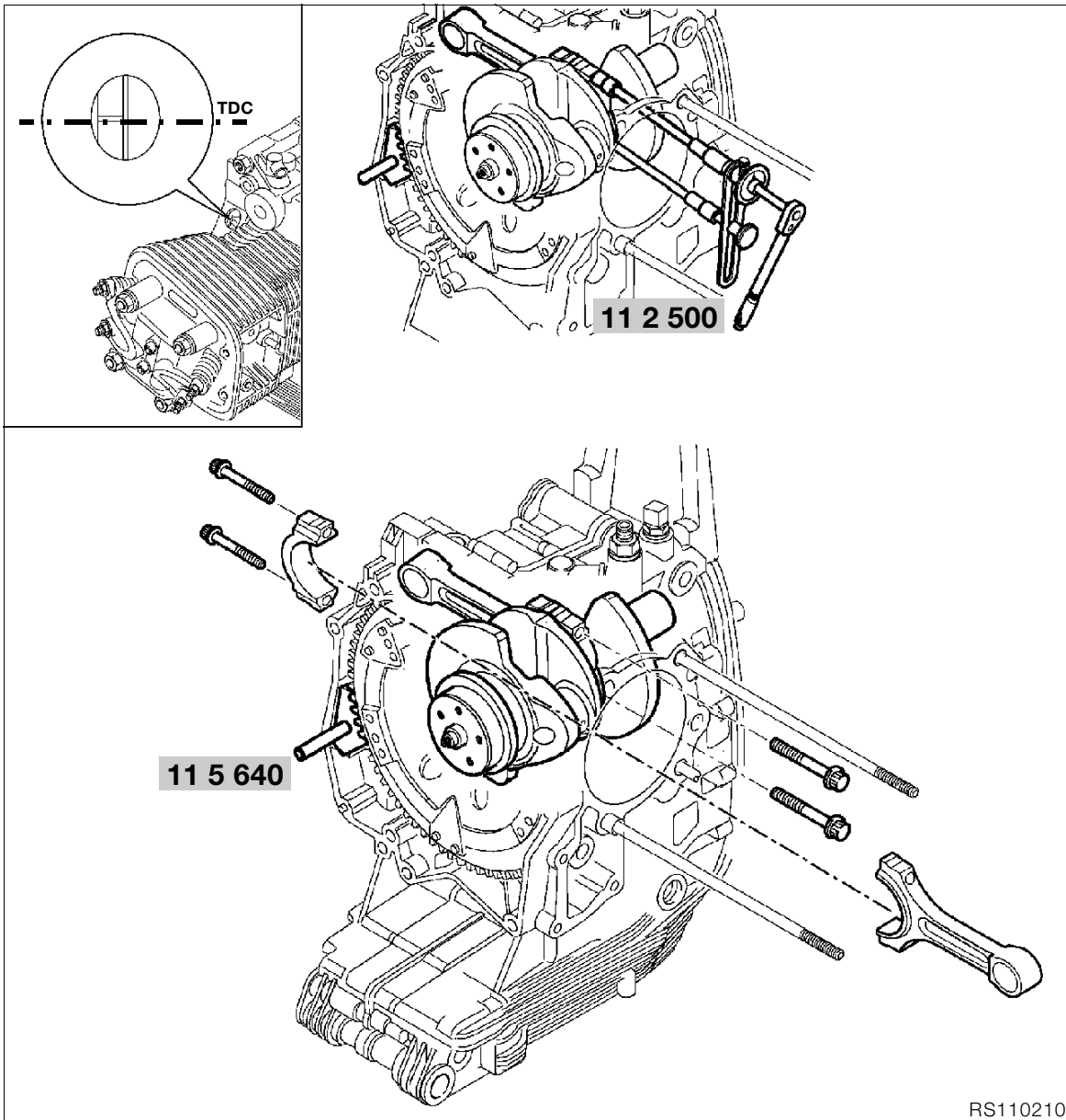
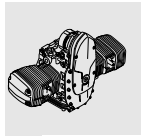

### Removing/installing conrod

- Turn crankshaft to TDC position.
- Lock the clutch housing with retaining fixture, **BMW No. 11 5 640**.
- Remove conrod.



**Note:**

Conrods can also be removed/installed with the crankshaft removed.



**Caution:**

Do not accidentally confuse conrods or bearing shells.

- Install conrods.

**Installed direction of conrods:**

.....lettering facing up



**Caution:**

Oil the bearings.

- Screw the big end bolts in by hand, then tighten with an angle-indicating wrench, **BMW No. 11 2 500**.



**Caution:**

Use big end bolts once only.



**Tightening torque:**

Big end bolts oiled  
 Joint torque..... 20 Nm  
 Wrench angle..... 80 °

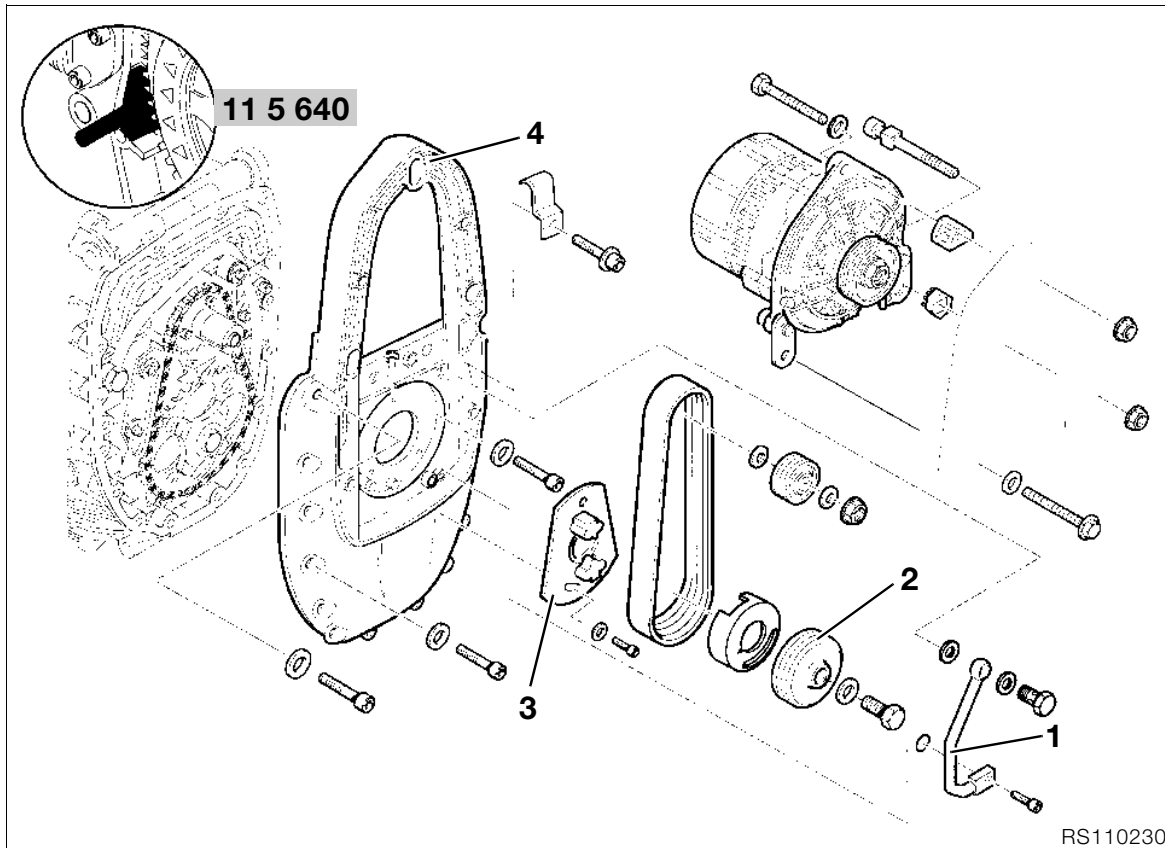

RS110230

### Removing and installing alternator cover with engine installed

- Remove dualseat.
- **[RS/GS/RT]** Remove side fairings.
- Remove fuel tank.



#### Caution:

Disconnect ground (earth) lead from battery.  
Insulate ground (earth) lead.

- **[RS/GS/R]** Remove starter motor cover.
- Remove starter motor.
- Remove rear leading link mount.

### Removing alternator mount cover

- Remove alternator.
- Remove rotary breather line (1).
- Lock clutch housing with retaining device, **BMW No. 11 5 640**.
- Remove pulley (2).
- Remove magnetic gate (3).



#### Note:

If complete alternator mount cover is removed, leave magnetic gate (3) installed.

- Remove alternator mount cover (4).

## Renewing radial shaft seal in alternator mount cover

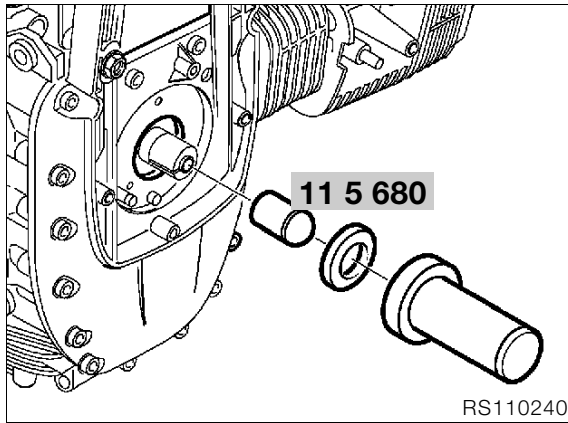
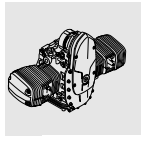

- Carefully lever radial shaft seal out, using a screwdriver.
- Drive in a new radial shaft sealing ring with drift and sleeve, **BMW No. 11 5 680**,



### Note:

Slide new radial shaft seal over taper on sliding sleeve, pre-shape and pull off.

## Renewing radial shaft seal for rotary breather

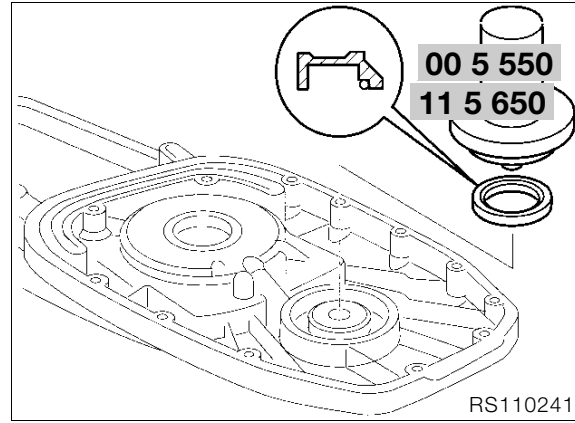

- Carefully lever radial shaft seal out, using a screwdriver.
- Carefully pre-form the lip of the radial shaft seal by hand.
- Drive in the new radial shaft seal (oiled lightly) using handle, **BMW No. 00 5 550**, and drift, **BMW No. 11 5 650**.



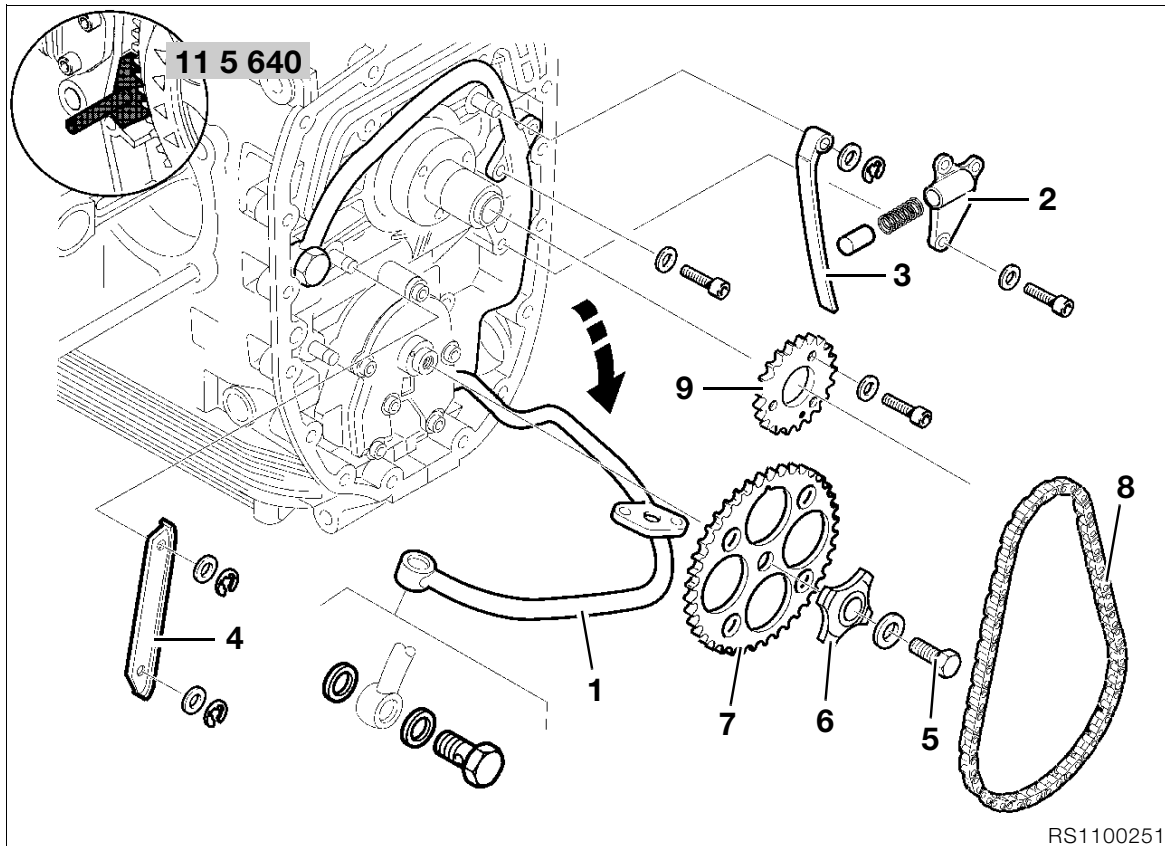

RS1100251

### Removing auxiliary-shaft drive

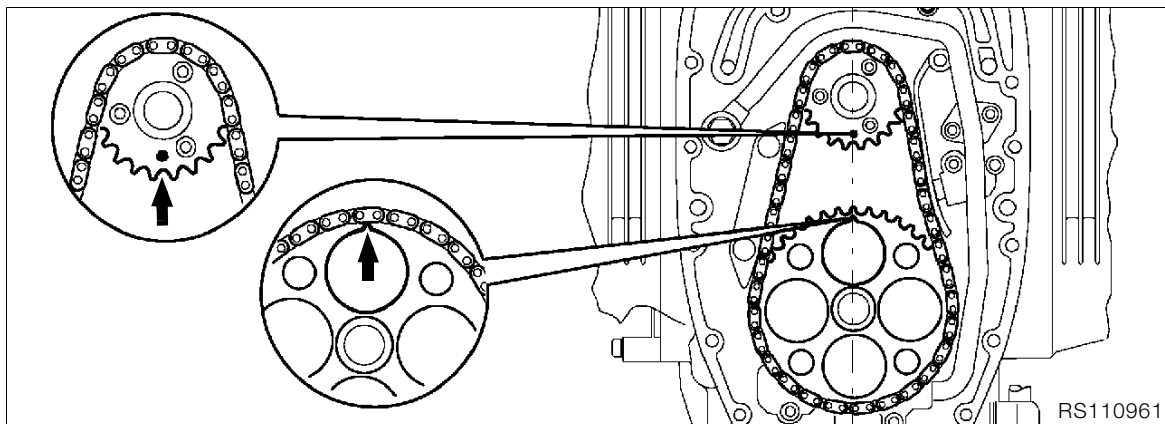

RS110961

- Align markings (arrows) on timing pinion and chain sprocket.
- Unscrew and remove cooling oil pipe (1)/swing the pipe forwards.
- Remove chain tensioner (2).
- Remove chain tensioning rail (3).
- Remove chain guide rail (4).
- Lock the clutch housing with retaining device, **BMW No. 11 5 640**.
- Unscrew and remove chain sprocket retaining bolt (5).
- Remove rotor (6) with chain sprocket (7) and timing chain (8).
- If necessary, remove chain sprocket (9).

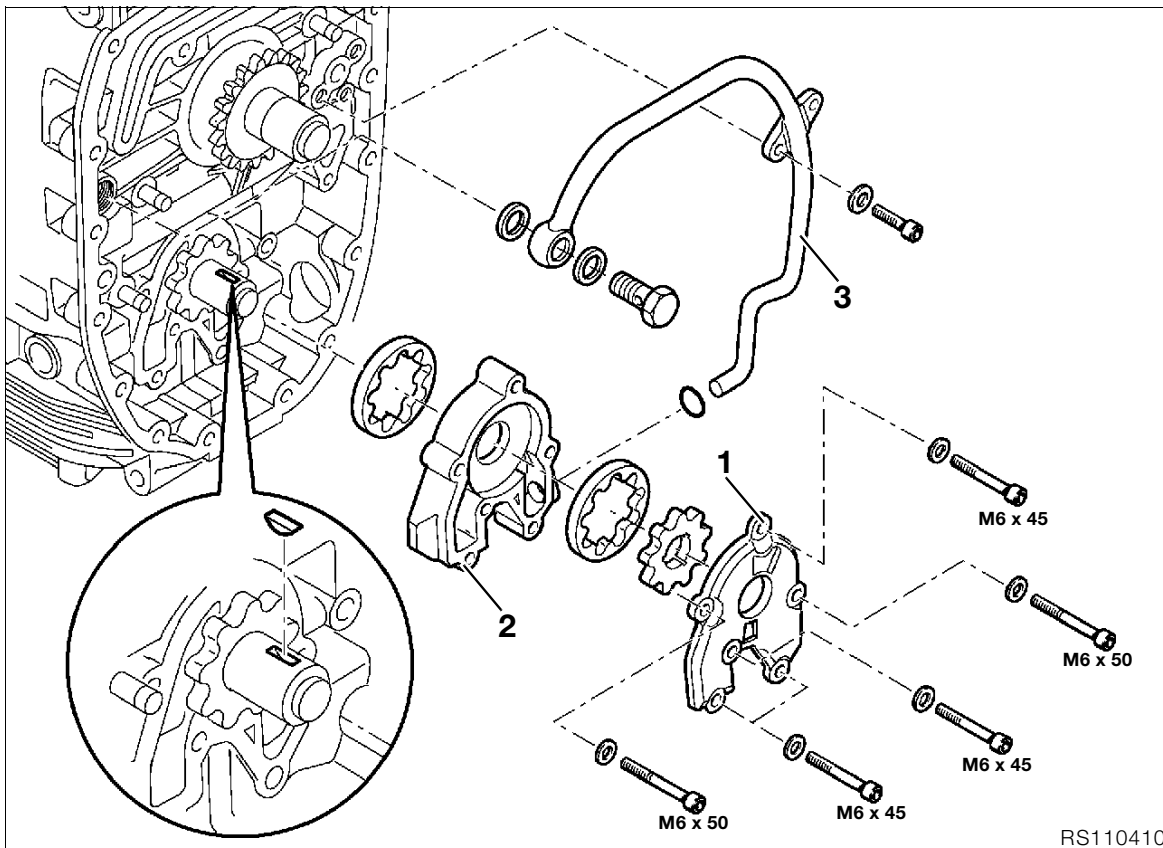
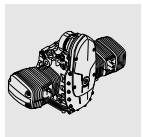

### Removing oil pump

- Remove oil pump cover (1).
- Remove complete oil pump (2) together with cooling oil pipe (3), and dismantle.

#### **Caution:**

Check installed positions of parts which have already been run together.

### Oil temperature regulator

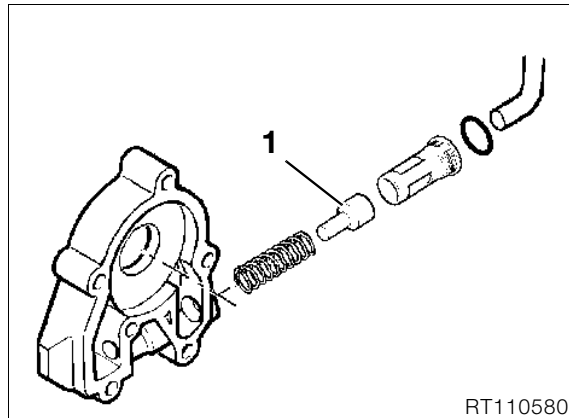

- Expanding element (1).



#### **Note:**

Do not dismantle the oil temperature regulator.

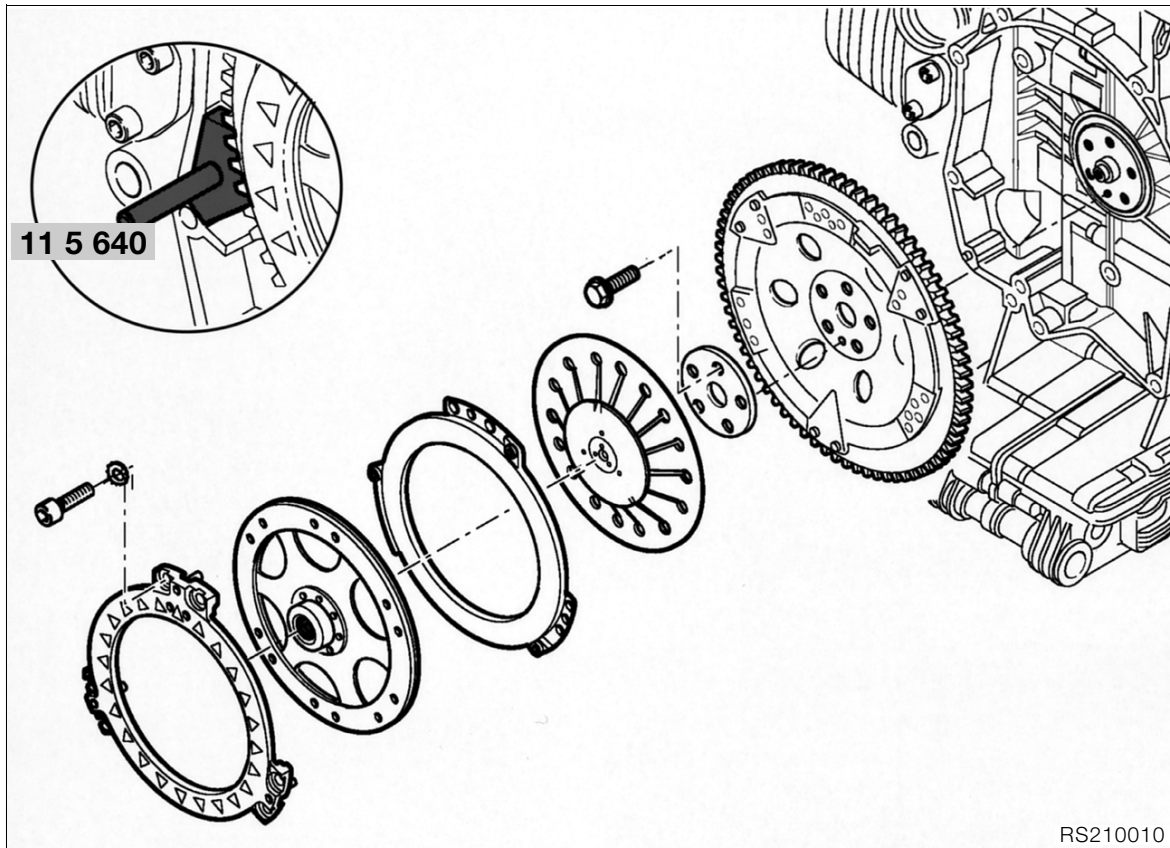

RS210010

### Removing radial shaft seal on crankshaft with engine installed

- Lock clutch housing with retaining device, **BMW No. 11 5 640**.
- Remove clutch.

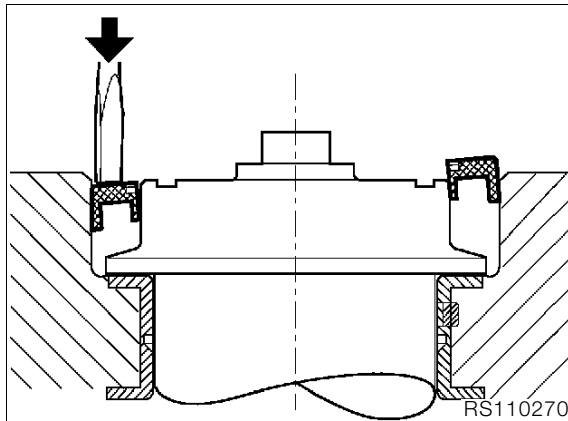

- Carefully lever radial shaft seal out, using a screwdriver.

#### **Caution:**

Avoid damaging the sealing faces on the housing and the crankshaft.

#### **Note:**

When dismantling the crankcase, the radial seal can be taken out.

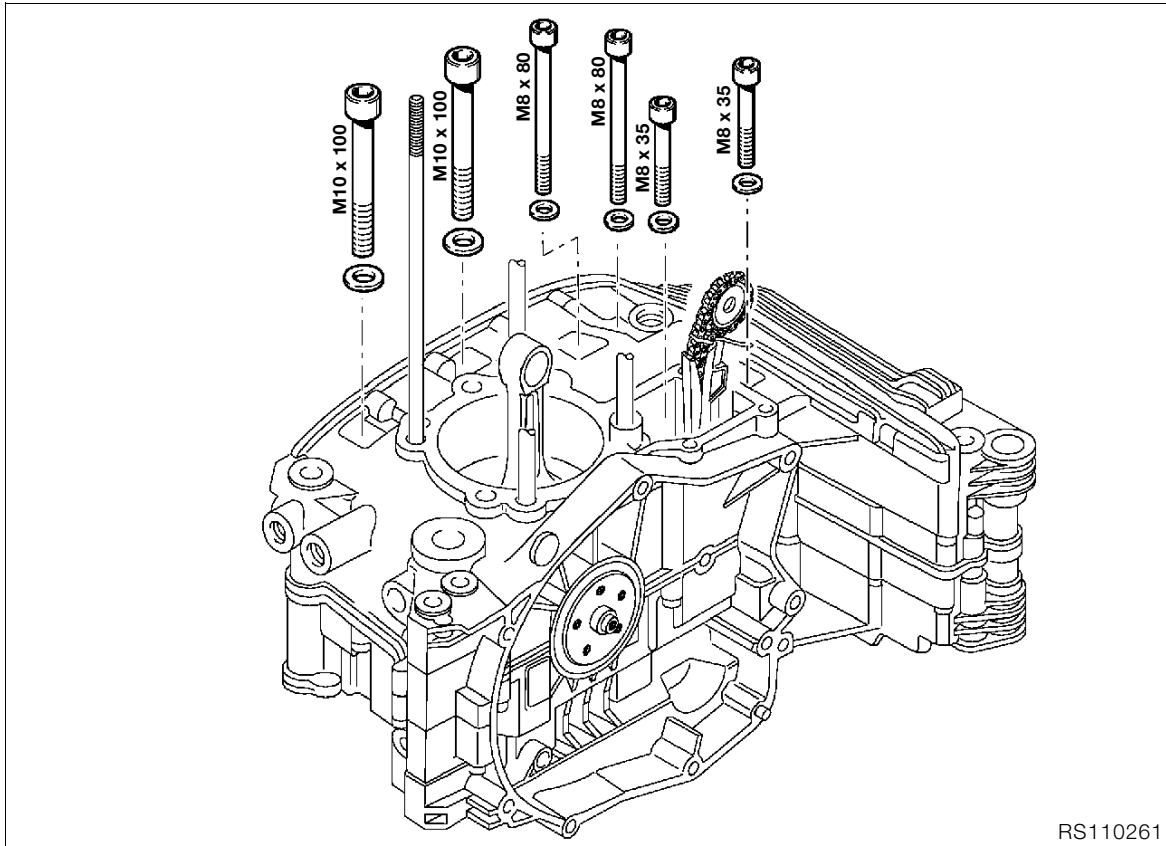
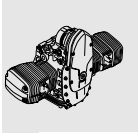

### Dismantling crankcase

- Turn engine on to its side.
- Remove screws on right side.

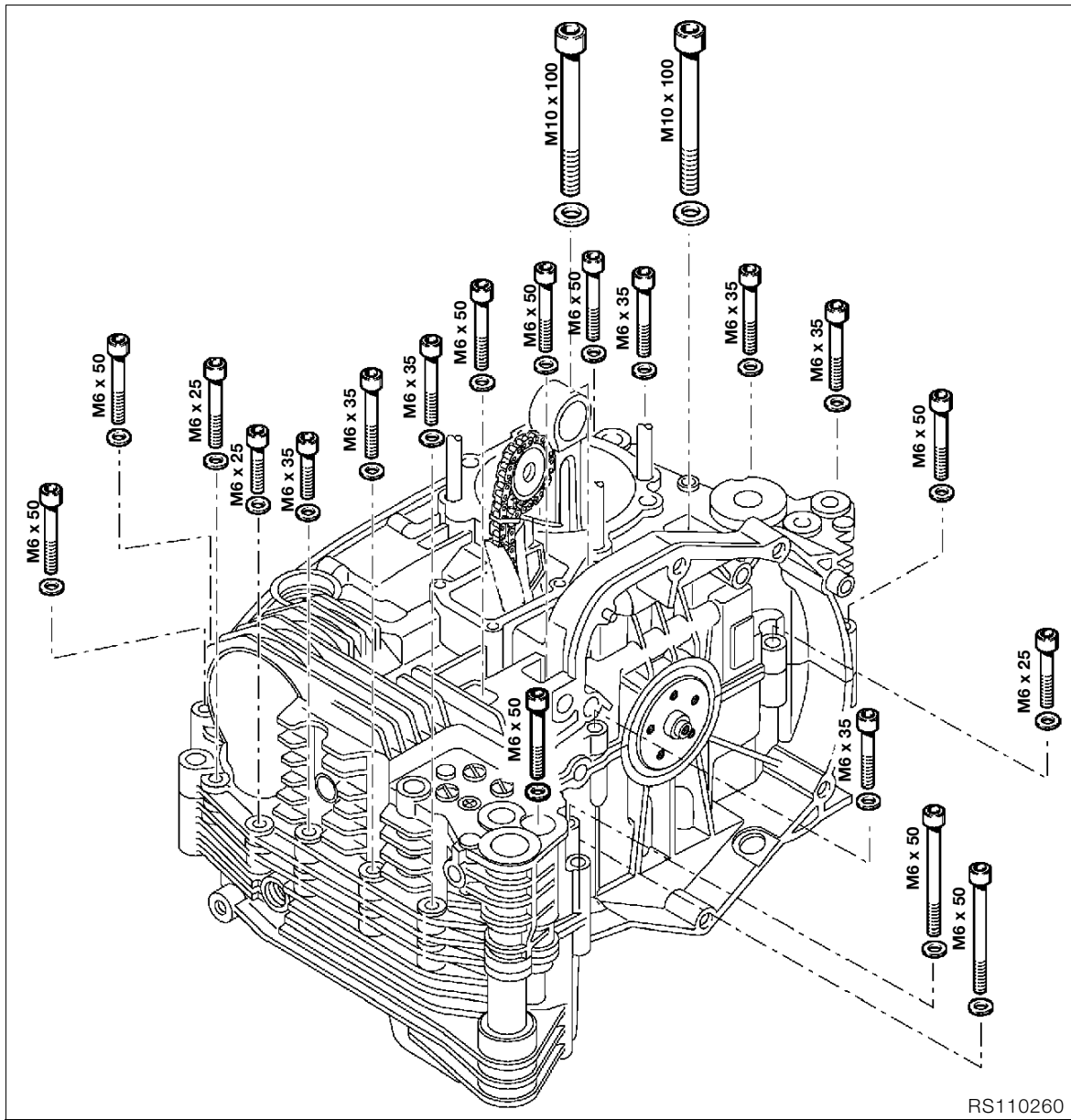

- Turn engine on to its side.
- Remove screws on left side.
- Remove upper section of crankcase.

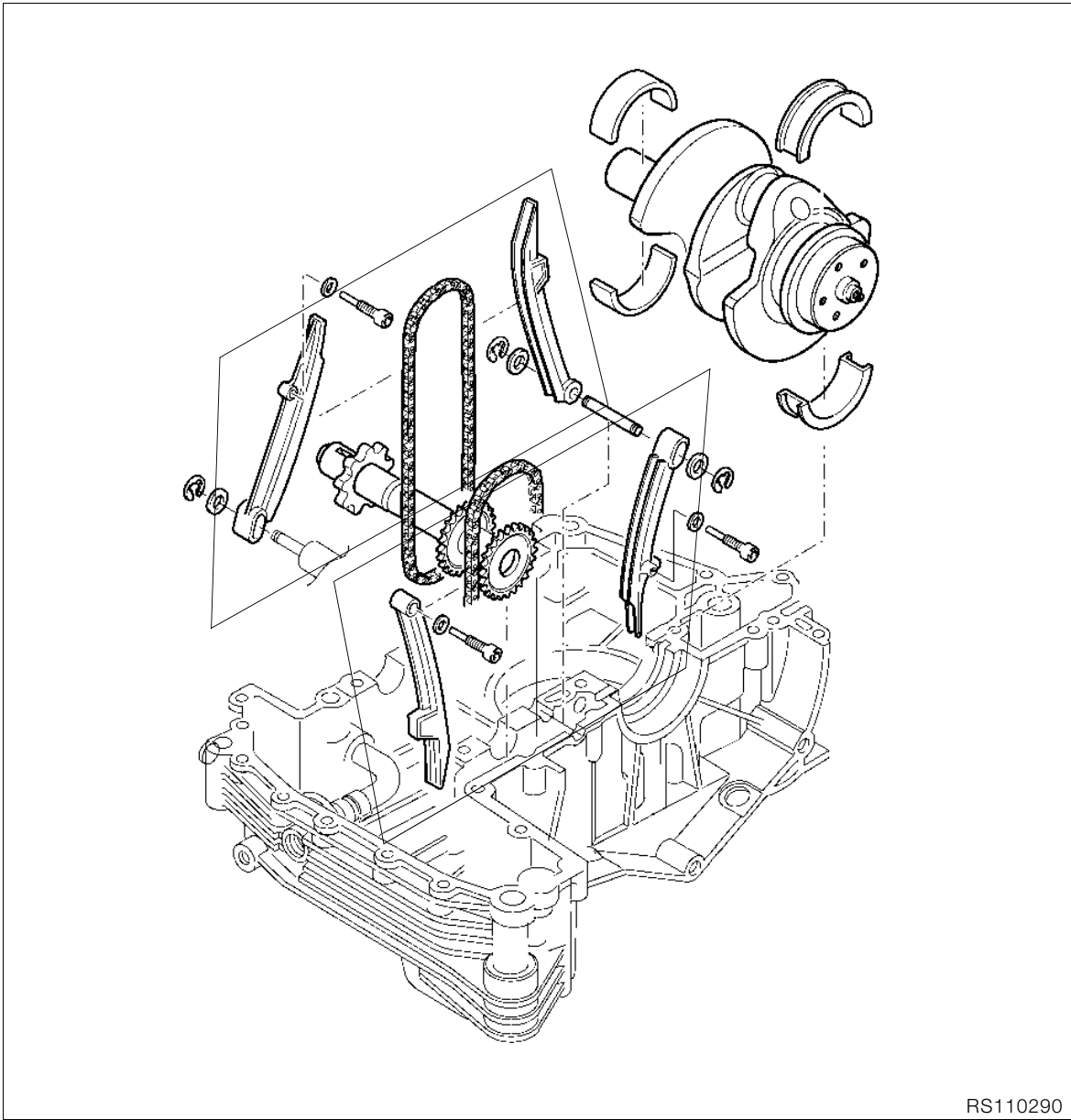
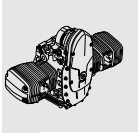



RS110290

Removing crankshaft, auxiliary shaft  
and timing chain tensioning and slide  
rails

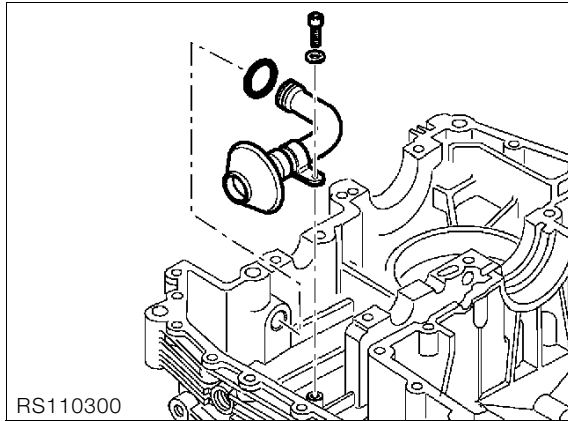
## Removing and installing oil pick-up basket



 **Tightening torque:**  
M6 screw .....9 Nm (0.354 in)

 **Caution:**  
Make sure that the O-ring is not omitted, and is installed undamaged.

## Replacing oil level sight glass

- Pierce the plastic disc with a large screwdriver and lever out the oil level sight glass.
- Coat the sealing face of the new oil level sight glass with engine oil and drive it in with drift, **BMW No. 00 5 550**.

## Removing conrods

- Clamp crankshaft in a vise provided with protective jaws.
- Remove conrod

 **Caution:**  
Do not accidentally confuse the conrods.

## Checking conrods

- Check conrod dimensions.  
➔ See Technical Data.

 **Caution:**  
Sintered-metal conrods must never be straightened – risk of fracture.

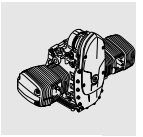

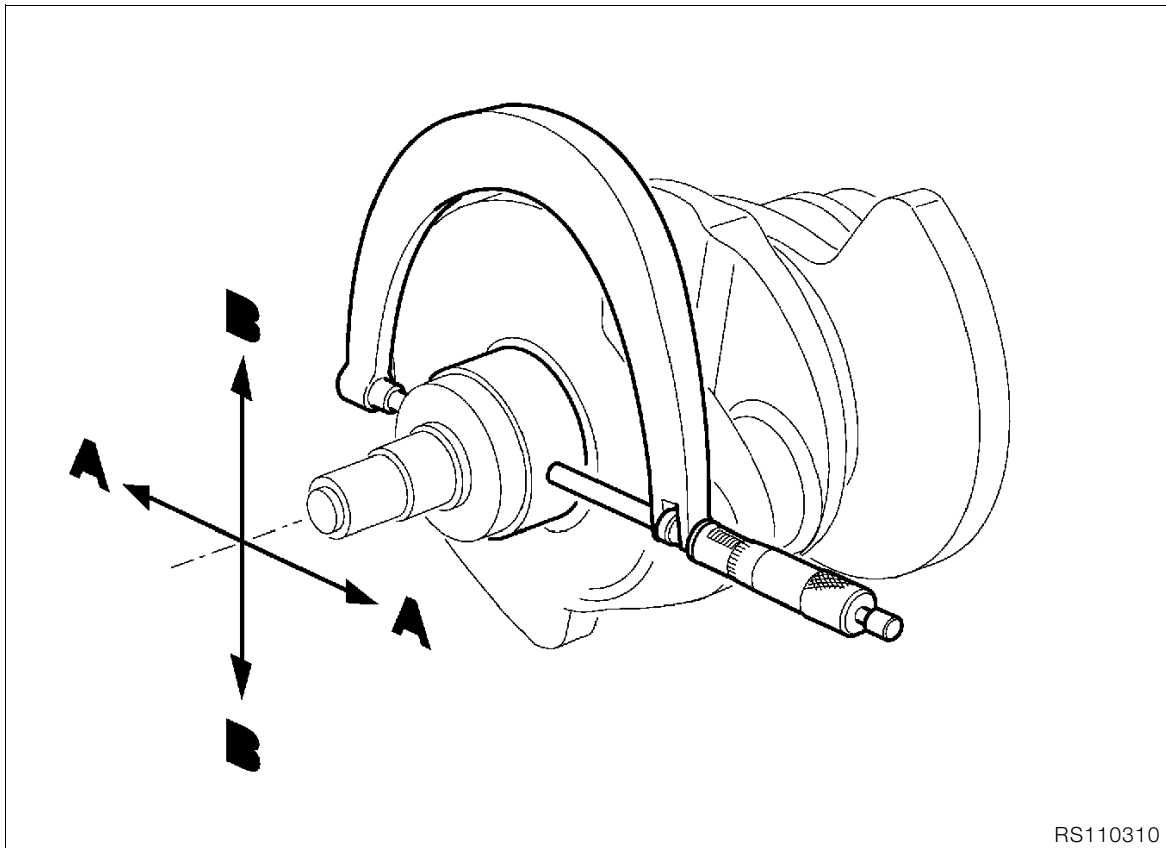
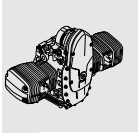

## Measuring main and big end bearing play

### Measuring radial bearing play

- Measure main bearing journal with an external micrometer crosswise in two planes, A and B.
  - Enter measured values on record sheet.
- ➡ See Technical Data.



### Caution:

The crankshaft can only be reground in grinding stage 0; after this it must be rehardened and finished. Grinding stages are identified by a paint mark on the front crank web.

➡ See Technical Data

If the bearing shells have to be replaced, note colored marks on crankpins and big end bearings.



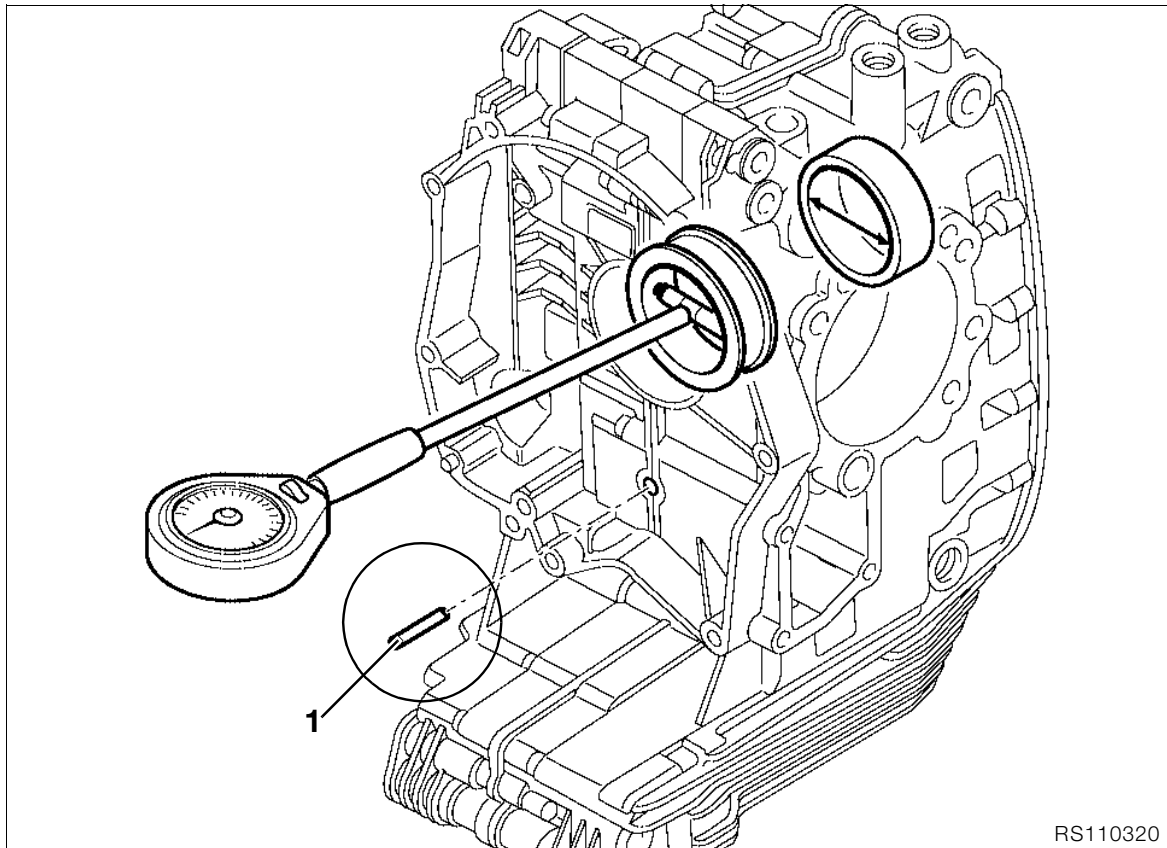

RS110320

### Install main bearings

- Insert tensioner rail/slide rail pivot pin (1) for centering purposes.
- Tighten M8 and M10 housing screws..

### Tightening torque/tightening sequence:

1. M10 screw (oiled) ..... 45 Nm
2. M8 screw (oiled) ..... 20 Nm

- Measure main bearings front/back in the load direction.
  - Enter measured values on record sheet and determine main bearing play values.
- ➡ See Technical Data.

### Measuring axial bearing play

- Place crankshaft in engine block.
- Insert tensioning rail/slide rail pivot pin (1) for centering purposes.
- Tighten housing screws.

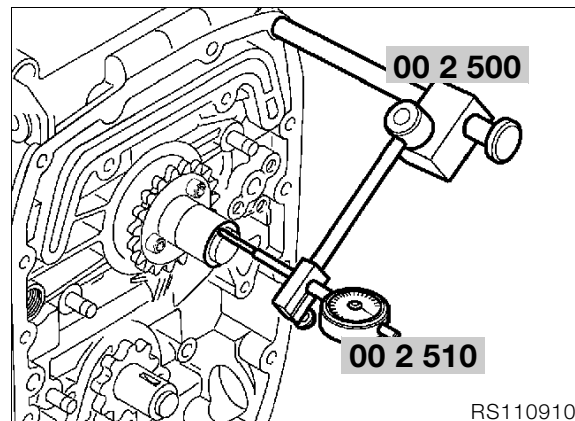

RS110910

- Screw measuring device **BMW No. 00 2 500**, with dial gauge, **BMW No. 00 2 510**, in the tapped hole for the alternator mount cover.
  - Move crankshaft forwards and backwards, and read off play at dial gauge.
- ➡ See Technical Data.

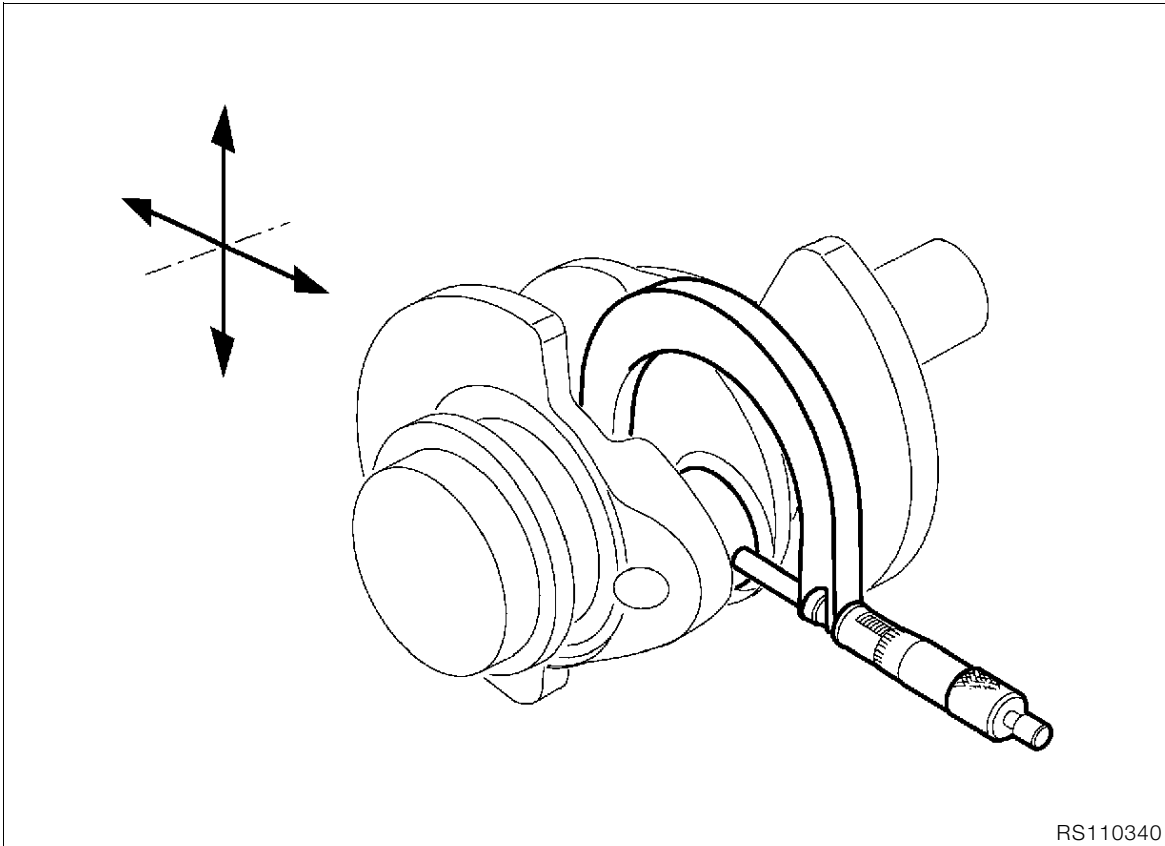
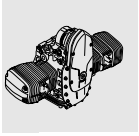

RS110340

### Measuring big end bearing play

- Measure crankpin with an external micrometer in the thrust direction and offset through 90°.

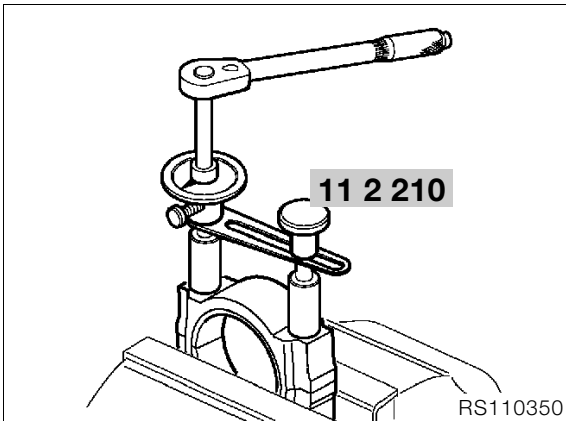

RS110350

- Install bearing shells and assemble conrods.
- Tighten big end bolt with tightening angle indicator, **BMW No. 11 2 210**.



#### ! Tightening torque:

Big end bolts oiled  
 Joint torque ..... 20 Nm  
 Wrench angle ..... 80°

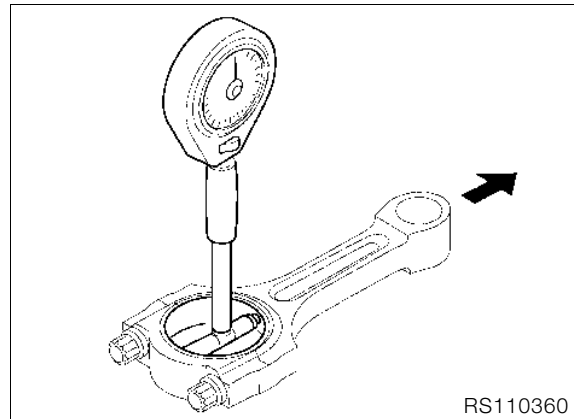

RS110360

- Measure big end bearing with internal gauge in thrust direction.
  - Enter measured values on record sheet and determine big end bearing clearances.
- ➔ See Technical Data.

## Assembling engine

### Installing conrod

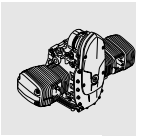
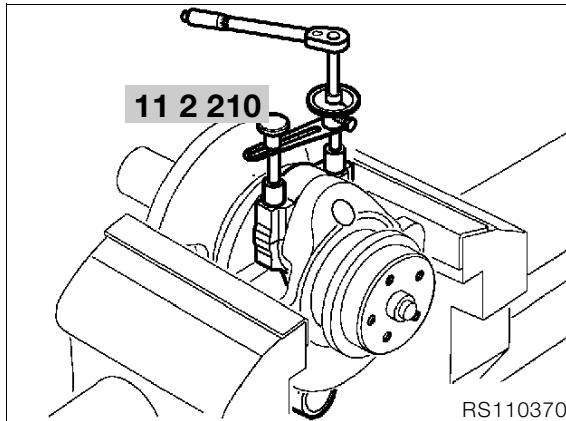

- Clamp crankshaft in a vise provided with protective jaws.
- Screw big end bolts (oiled) in by hand and tighten with tightening angle indicator, **BMW No. 11 2 210**.



#### **Caution:**

Oil the bearings. Do not accidentally confuse conrods or bearing shells. Always use new big end bolts.

#### **Installed direction of conrods:**

.....lettering facing up



#### **Tightening torque:**

Big end bolts (oiled)  
Joint torque ..... 20 Nm  
Wrench angle ..... 80°

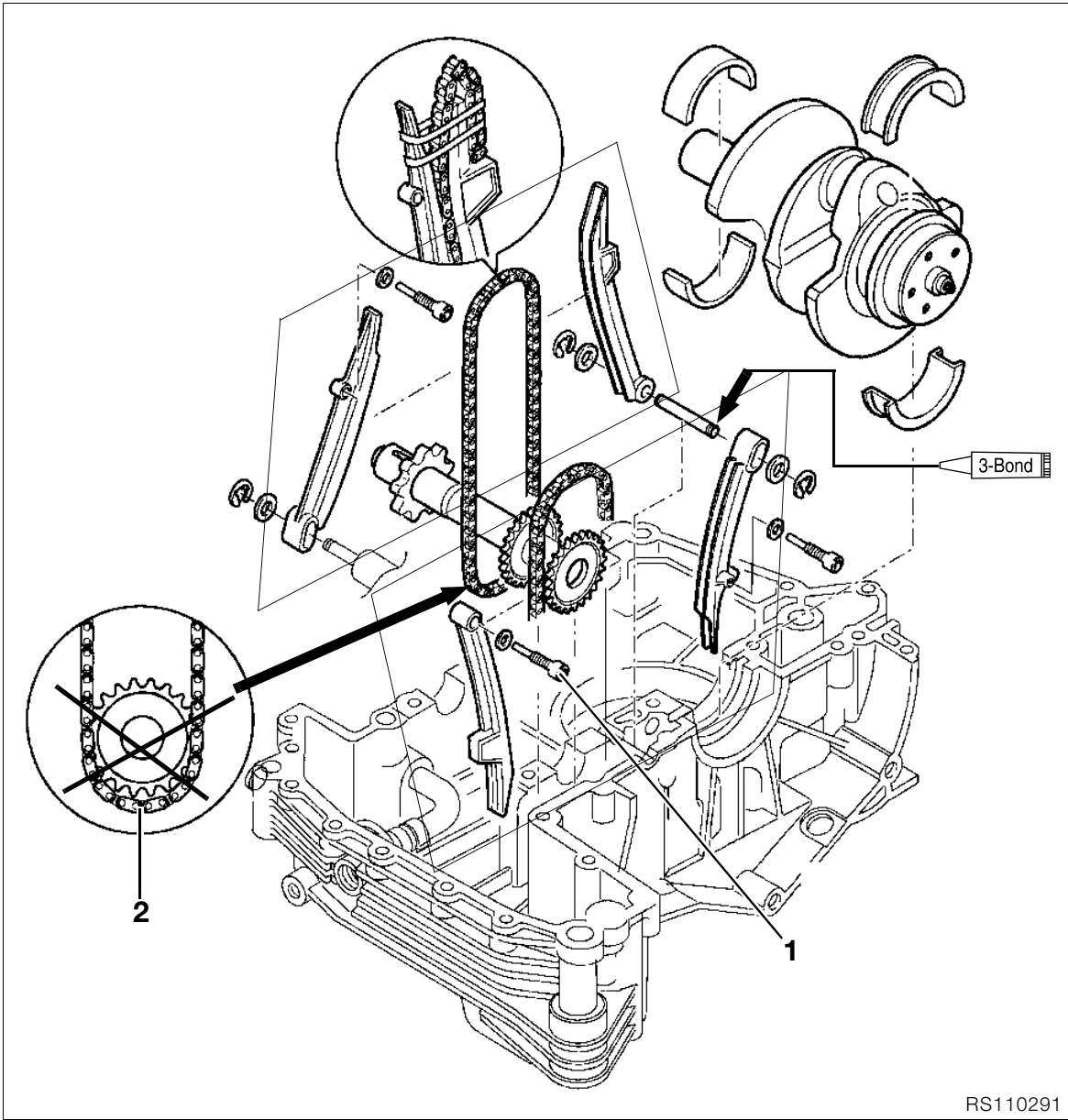
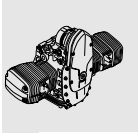

### Installing crankshaft

**⚠ Caution:**  
Oil the bearings.

### Installing auxiliary shaft/timing chains

**⚠ Caution:**  
Timing chains (2) must mesh fully with auxiliary shaft sprockets.

### Installing timing chain tensioning and slide rails

- Seal pivot pin for tensioning rail/slide rail at clutch side (arrow) with **3-Bond 1209**.
- Insert pivot screw (1) into chain tensioner rail, using a new sea.

**⚠ Tightening torqu:**  
Chain guide rail pivot pin ..... 18 Nm

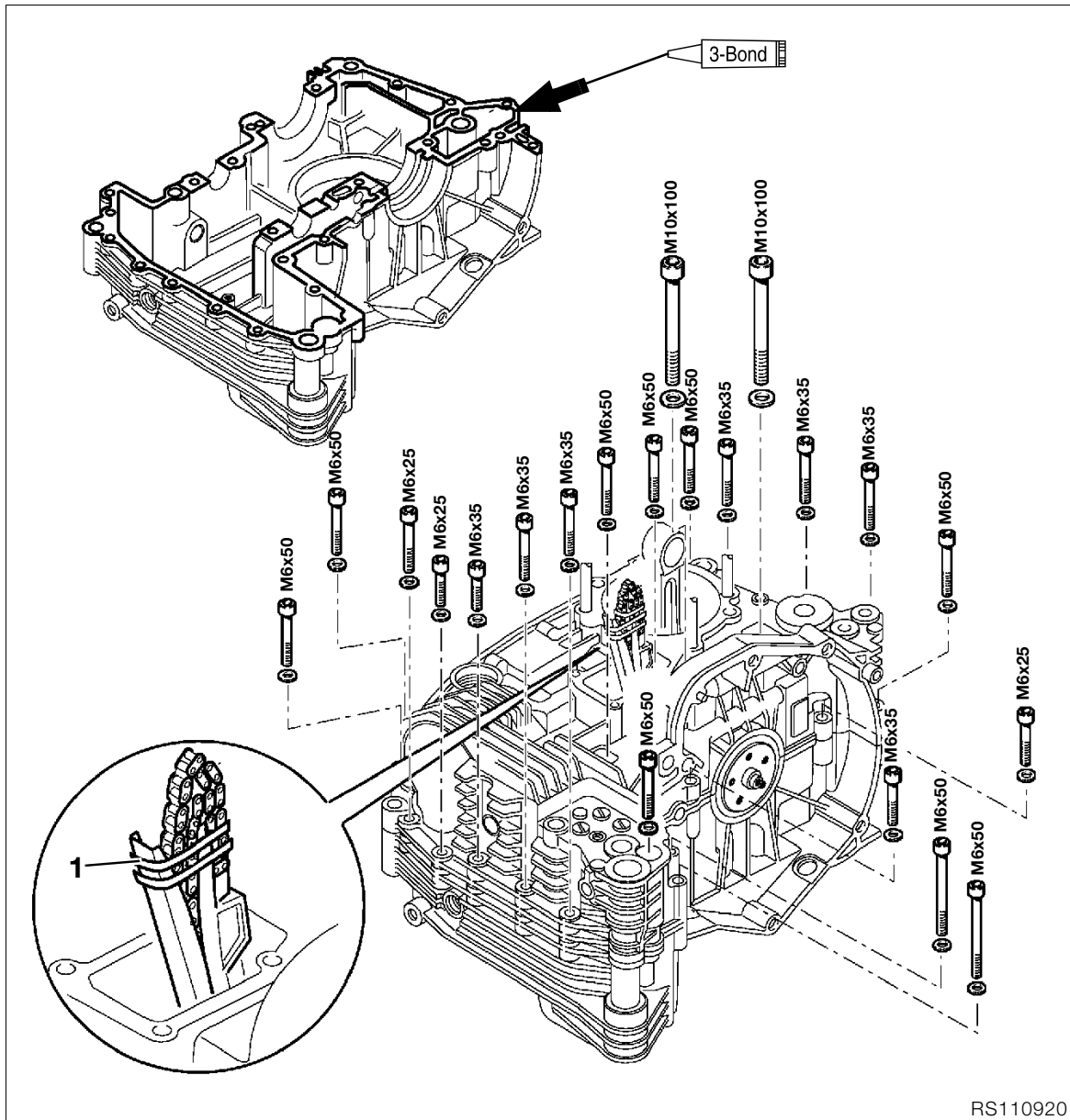

RS110920

### Assembling engine block

- Coat clean, grease-free sealing faces (arrow) with **3-Bond 1209**.
- Secure the timing chain with rubber band (1) to the timing chain tensioning and slide rail.

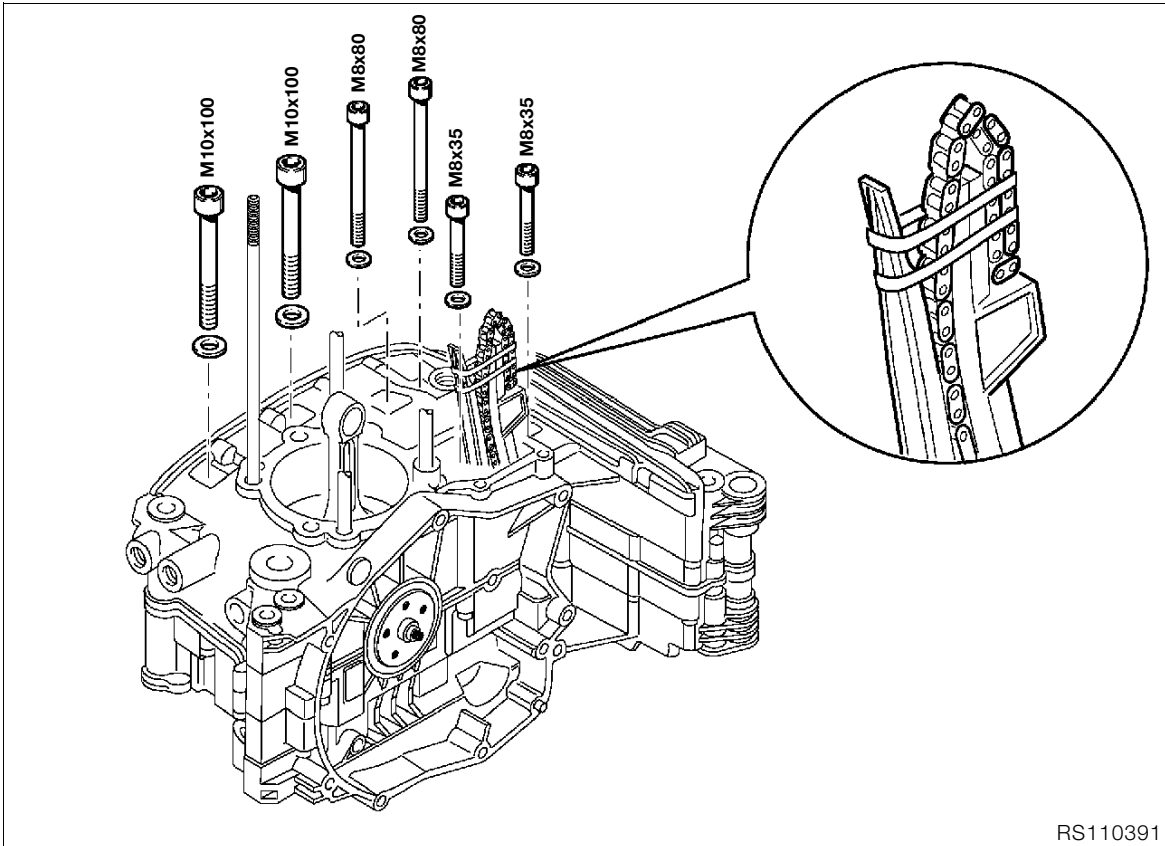
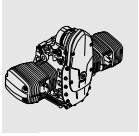

- Bolt the crankcase sections together.

**Tightening torque/tightening sequence:**

1. M10 screw (oiled) ..... 45 Nm
2. M 8 screw (oiled) ..... 20 Nm
3. M 6 screw ..... 9 Nm

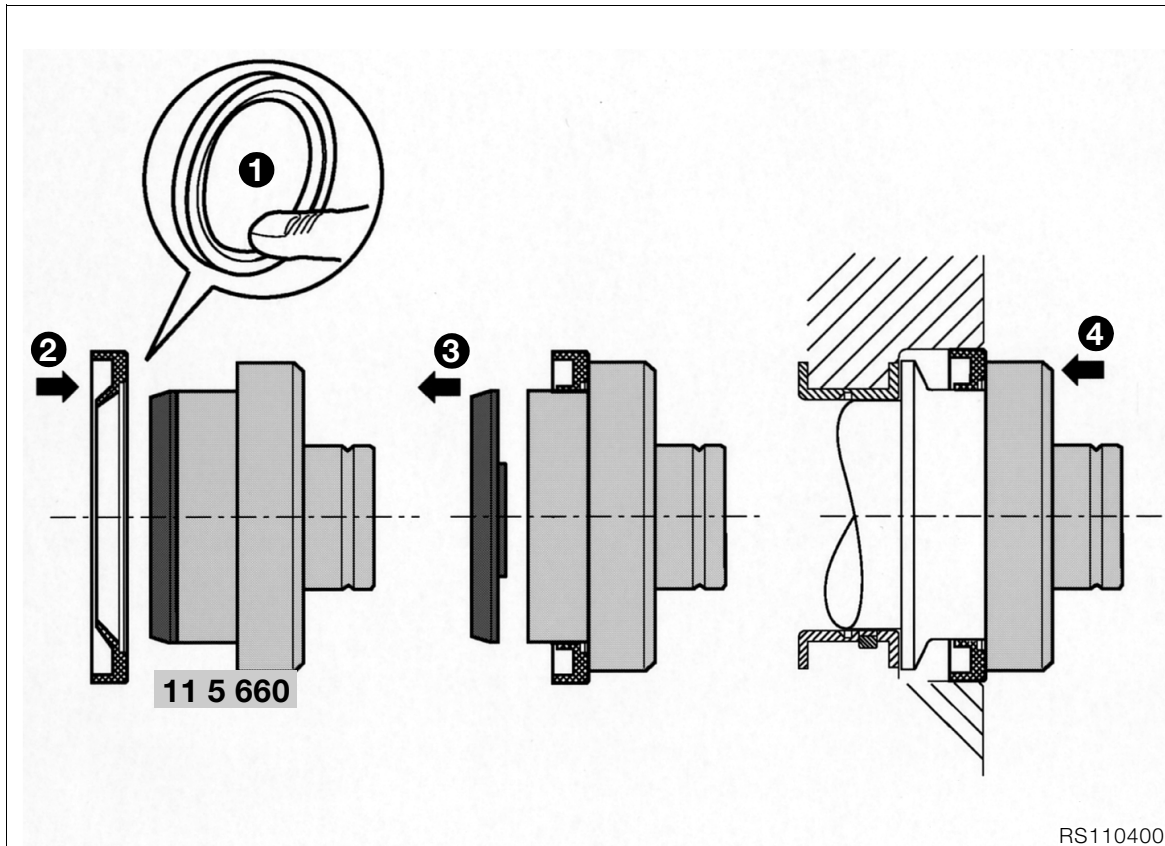

### Installing radial seal on crankshaft

- Pre-form the lip of the radial shaft seal carefully by hand (1).
- Oil the radial shaft seal at the sealing/contact surface.
- Place radial seal over sliding sleeve (2)/remove sliding sleeve (3).
- Drive radial shaft seal in with handle, **BMW No. 00 0 500**, and drift with sliding sleeve, **BMW No. 11 5 660** (4).

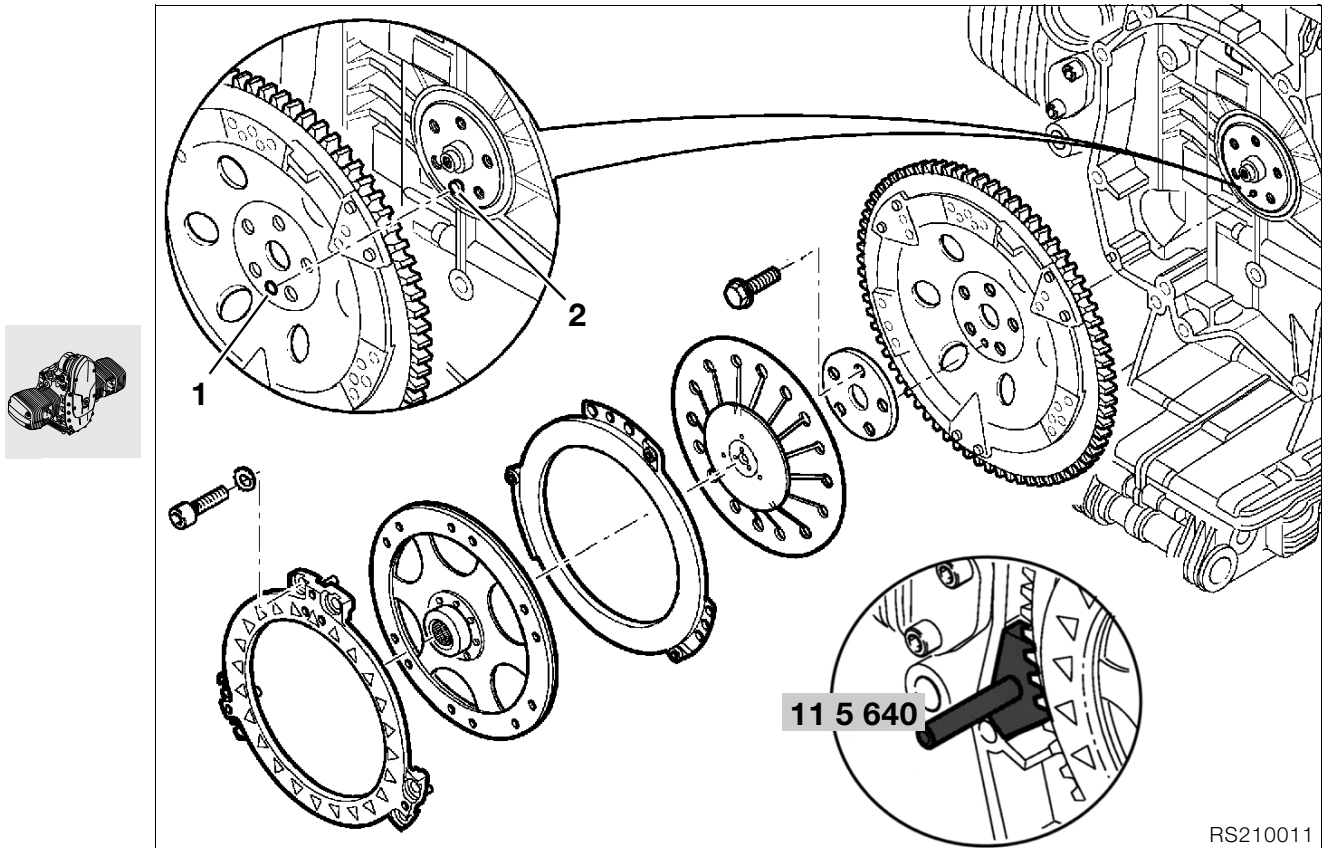

## Installing clutch housing



### Caution:

Always use new bolts for housing and cover.

- Install clutch housing with mark (1) aligned with crankshaft mark (2).
- Lock clutch housing with retaining device, **BMW No. 11 5 640**.
- Insert all screws by hand and tighten down.



### Tightening torque:

Clutch housing to crankshaft  
(screw threads oiled) ..... 40 Nm  
Additional wrench angle ..... 32°



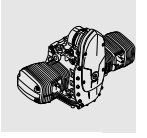
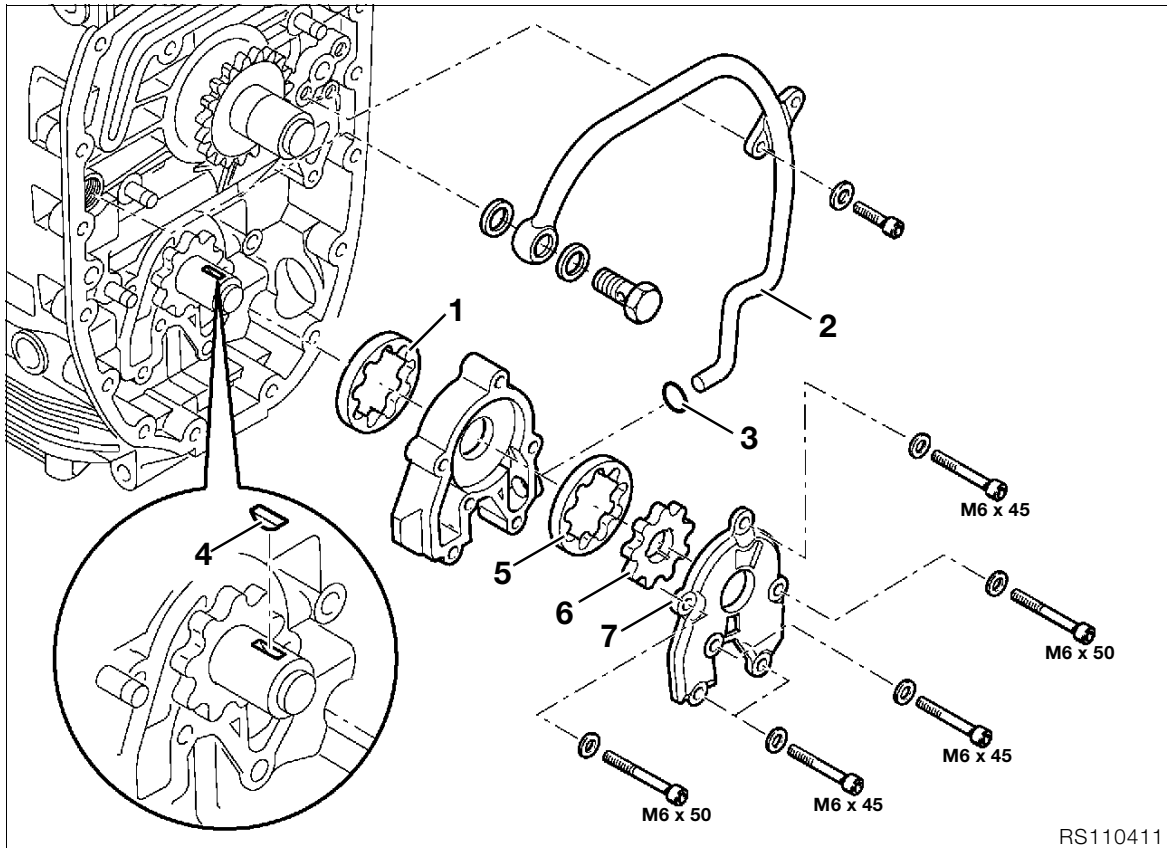

## Installing oil pump



### Caution:

Oil the sliding-contact faces.

- Install outer rotor (1) of oil pump in pump housing.
- Install oil pump housing with cooling oil pipe (2).



### Caution:

O-ring (3) must be in good condition.

- Install Woodruff key (4), outer rotor (5) and inner rotor (6) in cooling oil pump.
- Screw housing cover (7) on to oil pump.



### Caution:

Note: different lengths of screw.



### Tightening torque:

M 6 screw .....	9 Nm
Pressure relief valve .....	35 Nm
Oil pressure switch.....	30 Nm

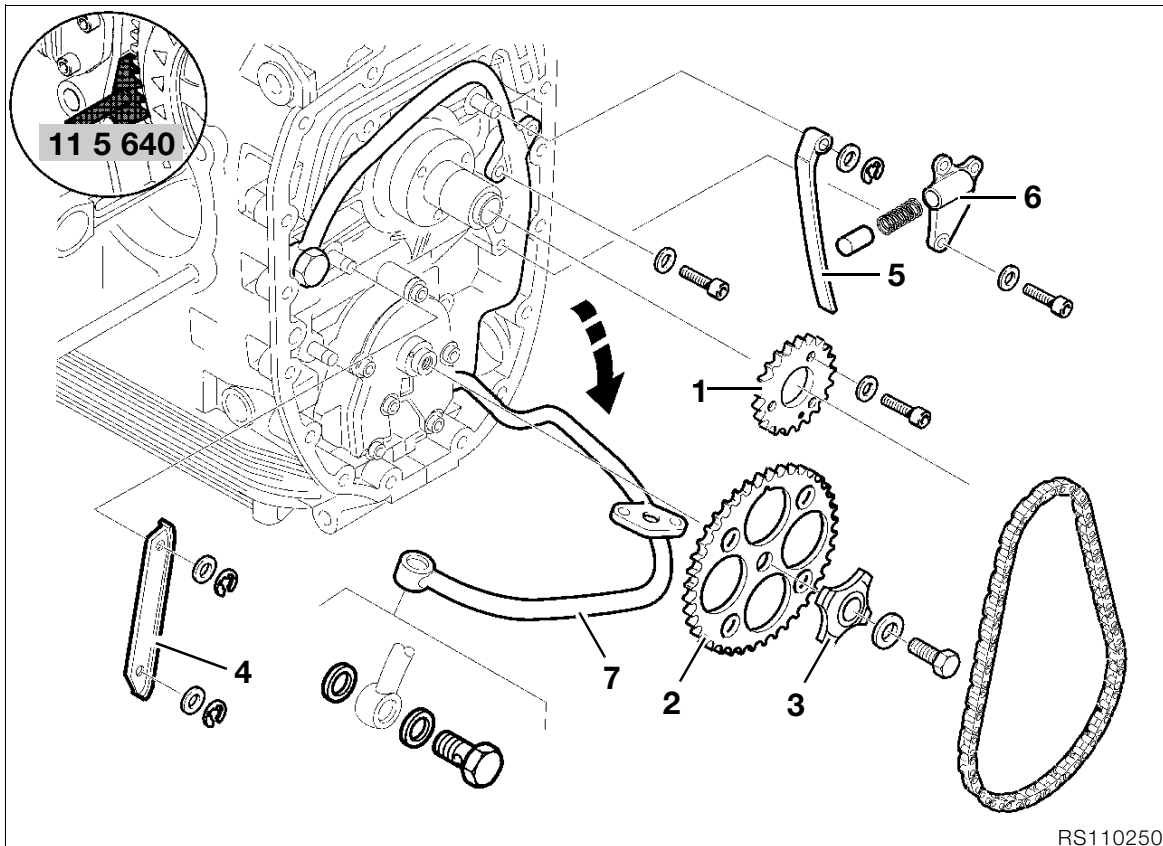

RS110250

### Installing auxiliary shaft drive

- Set crankshaft mark against mark on auxiliary shaft.

#### **Caution:**

Perform the work in accordance with the adjustment specification

➔ See Installing cylinder head.

- Lock clutch housing with retaining device, **BMW No. 11 5 640**.
- Install chain sprocket (1).

#### **Tightening torque:**

M 6 screw ..... 10 Nm

- Install drive-shaft chain with chainwheel (2) and rotor (3).

#### **Tightening torque:**

Retaining screw at chainwheel ..... 70 Nm

- Install/secure chain guide rail (4).
- Install/secure chain tensioner rail (5).
- Install chain tensioner housing (6) with piston and spring.

#### **Tightening torque:**

M 6 screw ..... 9 Nm

- Tighten down cooling oil line (7).

#### **Caution:**

Use a new sealing ring.

#### **Tightening torque:**

M 6 screw .....	10 Nm
Banjo screw for cooling oil line .....	25 Nm
Banjo screw for cooling oil line with oil vent valve .....	25 Nm

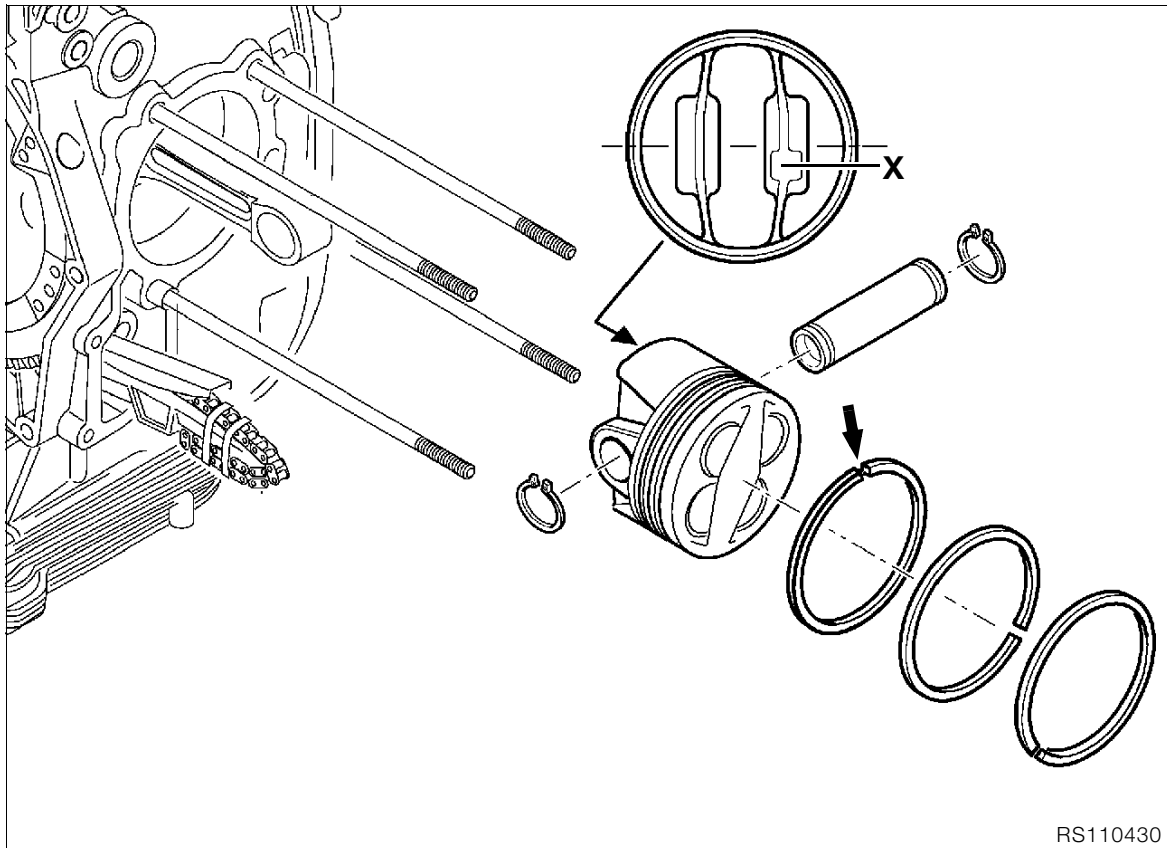

RS110430

## Installing pistons

- Turn joint in oil scraper ring (arrow) so that it faces upwards.
- Install piston ring gap offset by 120° in each case.

Production locating point **X** = install on exhaust side.



### Caution:

Ensure that retaining rings are properly seated on piston pin. Oil the sliding-contact faces. Always use pistons of the same weight class in any one engine.

**Markings:** ..... + or -  
 ➡ See Technical Data



### Caution:

Always install pistons and cylinders in pairs. Do not accidentally confuse pistons or piston pins

### Piston size identificatio

On piston crown A, B, AB (for either A or B cylinder), and on cylinder A, B

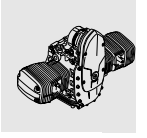

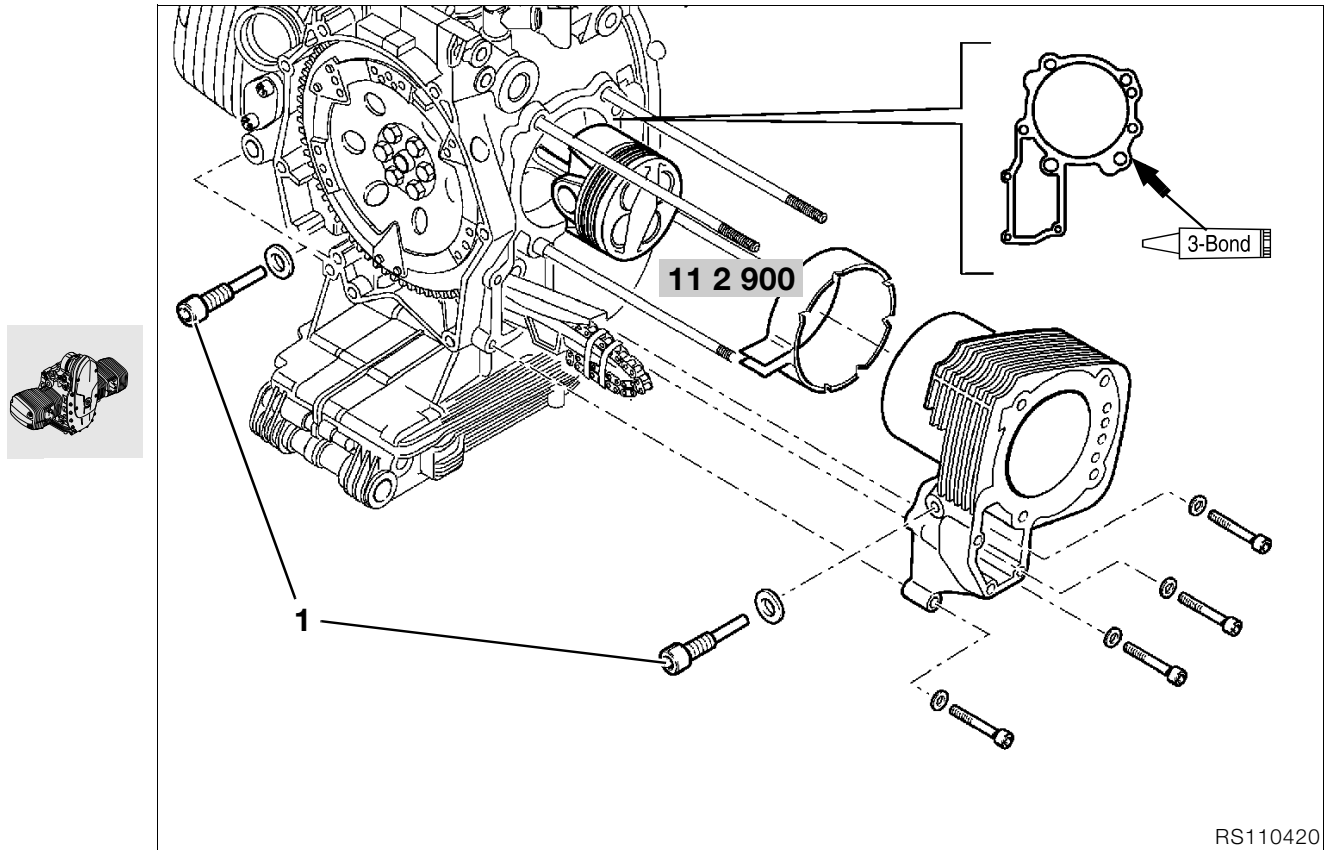

### Installing cylinders

- Apply **3-Bond 1209** to the cylinder base sealing face, which must be clean and free from grease.
- Oil the cylinder wall.
- Using piston ring clamp strap, **BMW No. 11 2 900/11 2 905**, compress the piston rings.
- Install the cylinder and at the same time pass the timing chain and the tensioning and guide rail through the timing case cavity.
- Tighten cylinder down firmly.
- Fit new seal to pivot pin for chain guide rail (1).
- Install chain sprocket.

**Tightening torque/tightening sequence:**

- 1. M 8 screw ..... 20 Nm
- 2. M 6 screw ..... 9 Nm
- 3. Pivot screw for chain guide rail ..... 18 Nm

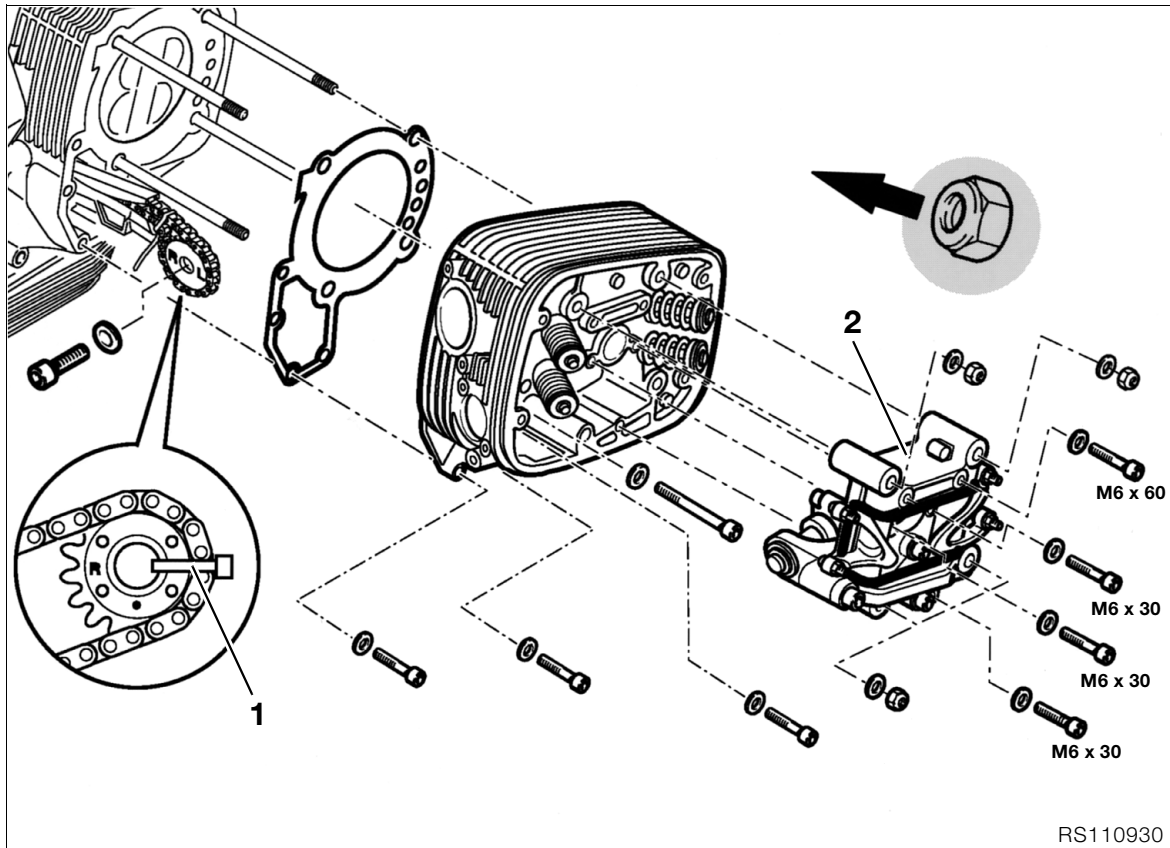

## Installing cylinder head

- Install cylinder head gasket.
- Fit cylinder head/insert correctly positioned camshaft chain sprocket (1) and timing chain into chain cavity.
- Install valve gear support (2).
- Tighten cylinder head down.

### **Caution:**

Install collar (arrow) of cylinder head nut towards cylinder head.

### **Tightening torque/tightening sequence:**

1. Tighten cylinder head nuts (oiled) crosswise
  - 1.1 Tighten all nuts ..... 20 Nm
  - 1.2 Tighten all nuts to correct angle ..... 90°
  - 1.3 Tighten all nuts to correct angle ..... 90°
2. M 10 screw ..... 40 Nm
3. M 6 screw ..... 9 Nm

### **Tightening torque:**

take up slack after 1000 km (app. 600 miles)  
Tighten cylinder head nuts crosswise

1. Unfasten one nut
2. Tighten one nut to initial value ..... 20 Nm
3. Tighten nut to wrench angle ..... 180°
4. Unfasten/retighten M10 screw ..... 40 Nm

- Fit camshaft chain sprocket in accordance with adjustment specification.
- Lock clutch housing with retaining device, **BMW No. 11 5 640**.
- Tighten camshaft chain sprocket.

### **Tightening torque:**

Camshaft sprocket retaining screw ..... 65 Nm

- Insert the left-side camshaft sprocket with pin into the camshaft and set the left cylinder to TDC on the ignition stroke.
- Fit camshaft chain sprocket in accordance with adjustment specification.
- Tighten camshaft chain sprocket.
- Install chain tensioner.
- Check that marks on camshaft sprockets are in accordance with adjustment specification.

### **Tightening torque:**

Chain tensioner ..... 32 Nm

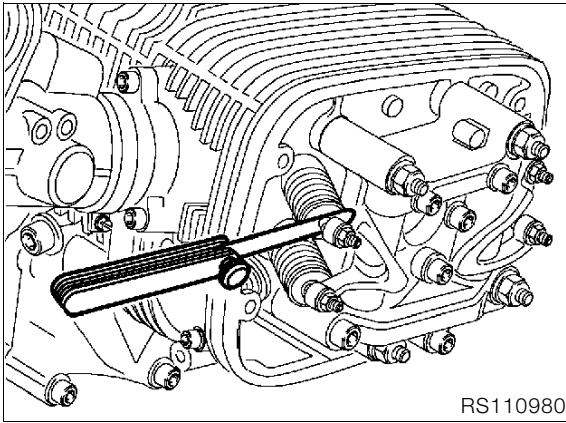

RS110980

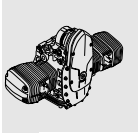

## Adjusting valve clearances

- Set piston to TDC on the ignition stroke.
- Measure valve clearance with feeler gauge.
- Correct valve clearance with adjusting screw and lock into position.

### Valve clearances with engine cold (max. 35 °C):

Inlet..... 0.15 mm (0.0059 in)  
Exhaust..... 0.30 mm (0.0118 in)



### Tightening torque:

Locknut..... 8 Nm

- Check valve clearance again; it must be possible to insert the feeler gauge between valve stem and rocker with only slight resistance to movement.

## Installing right cylinder head

### Adjustment specification



#### Caution:

When assembling, **always** start with the **right** cylinder.

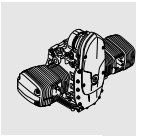
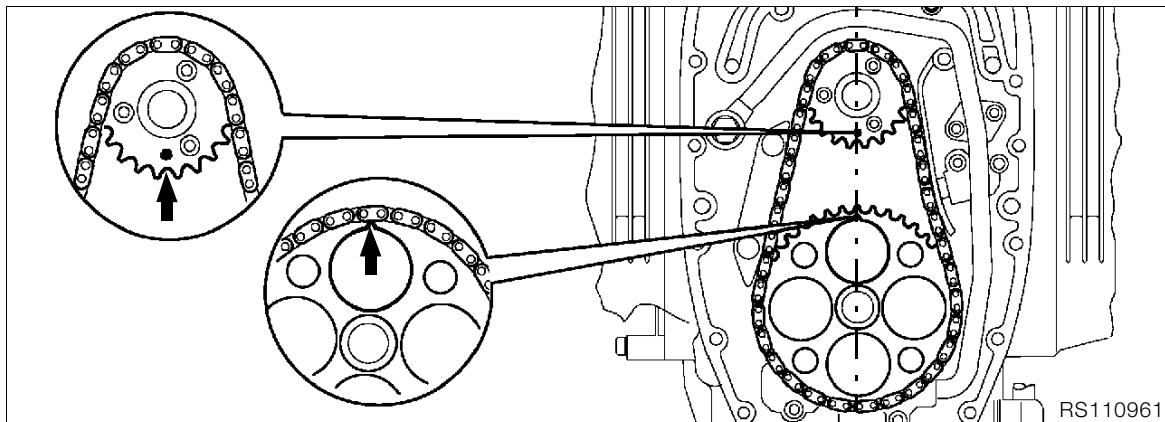

Right cylinder = at TDC on ignition stroke:  
marks (arrows) on chainwheel/auxiliary shaft and  
chain sprocket/crankshaft are aligned.

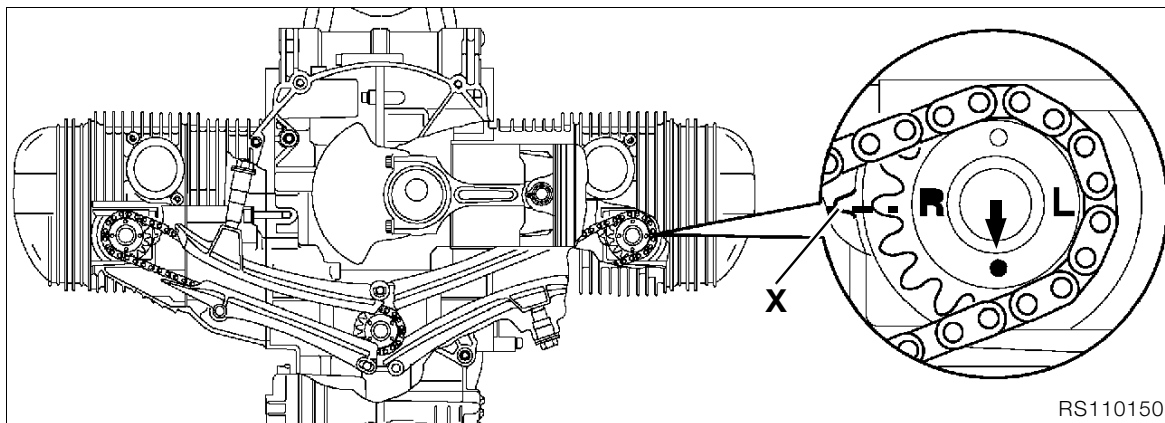

- Locate ignition-stroke TDC with insert pin, **BMW No. 11 2 650**, at hole in clutch housing and engine block.

Right cylinder = at TDC on ignition stroke  
Locating pin (arrow) on right camshaft sprocket  
points downwards.

Mark (**R** or **arrow**) and tip of tooth on right camshaft  
sprocket is **precisely** aligned with mark **X** on timing  
gear carrier.

- Check setting again with timing chain tensioner installed.

## Installing left cylinder head

### Adjustment specification



#### Caution:

When installing, **always** begin with the **right** cylinder.

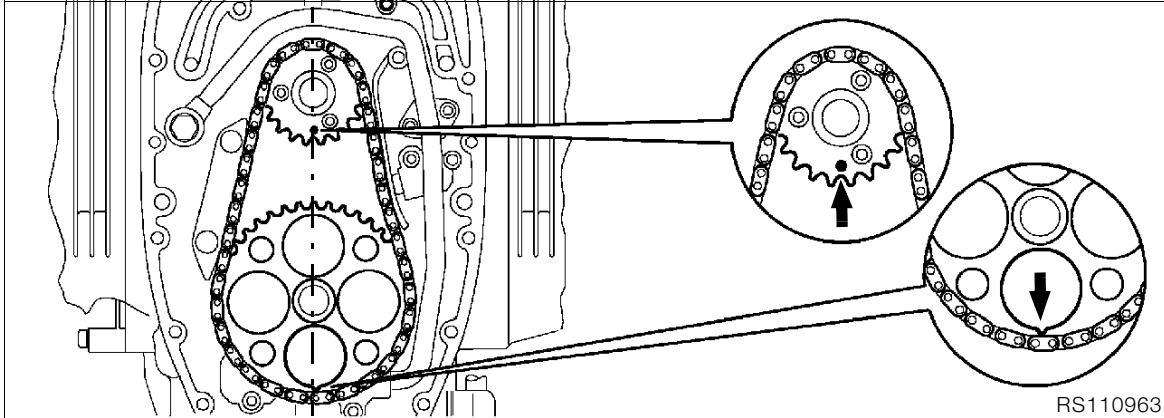

Left cylinder = at TDC on ignition stroke:  
Marks (arrows) on chainwheel/auxiliary shaft and  
chain sprocket/crankshaft point downwards.

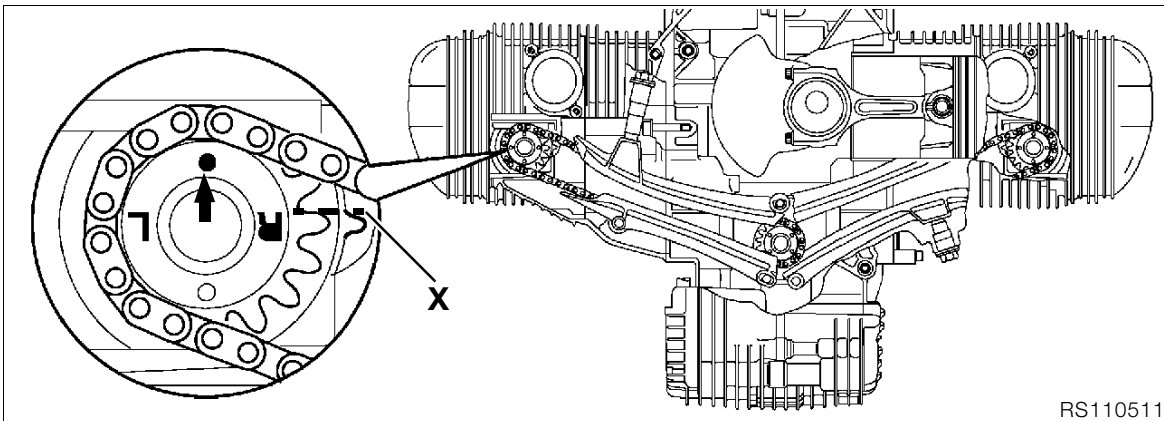

- Locate ignition-stroke TDC with insert pin, **BMW No. 11 2 650**, at hole in clutch housing and in engine block.

Left cylinder = at TDC on ignition stroke:  
Locating pin (arrow) on left camshaft sprocket points upwards.

Mark (**R** or **arrow**) and tip of tooth at left camshaft sprocket is aligned **precisely** with mark **X** on timing gear carrier.

- Check setting again with timing chain tensioner installed.



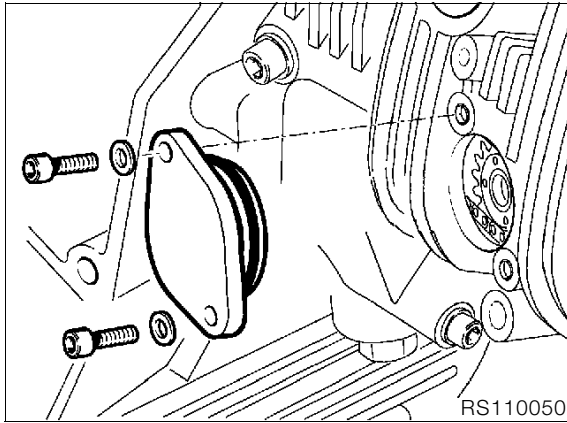

- Install the end cover with an O-ring which is in good condition.

**! Tightening torque:**

M 6 screw ..... 9 Nm

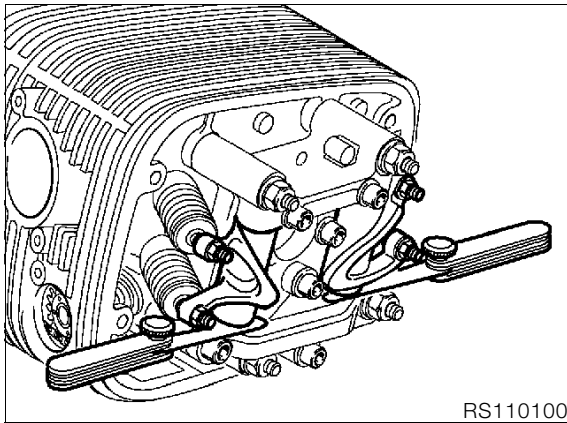

- If necessary, reduce end play to a minimum by repositioning the bearings.

**Rocker end float:**

min. .... 0.05 mm (0.00197 in)  
 max. .... 0.40 mm (0.0157 in)

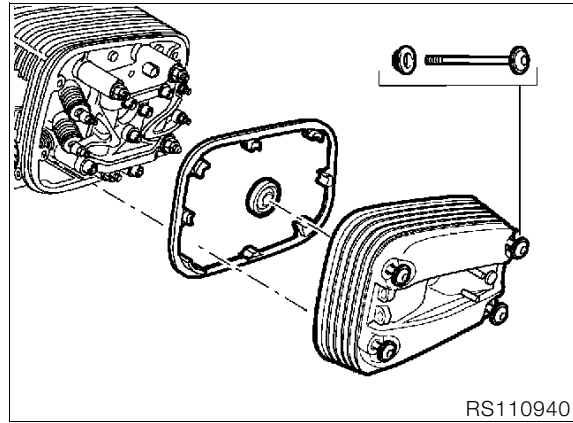

- Install cylinder head cover.

**! Caution:**

Ensure that gaskets are properly seated. Gaskets and sealing face must be free from oil and grease

**! Tightening torque:**

Cover screw ..... 8 Nm

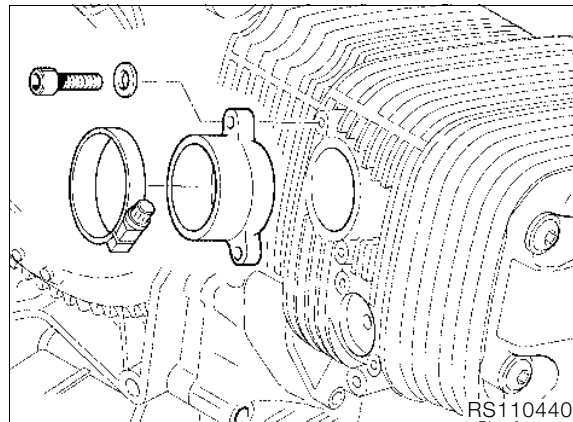

- Tighten air intake stub pipe.

**! Tightening torque:**

M 6 screw ..... 9 Nm

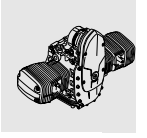

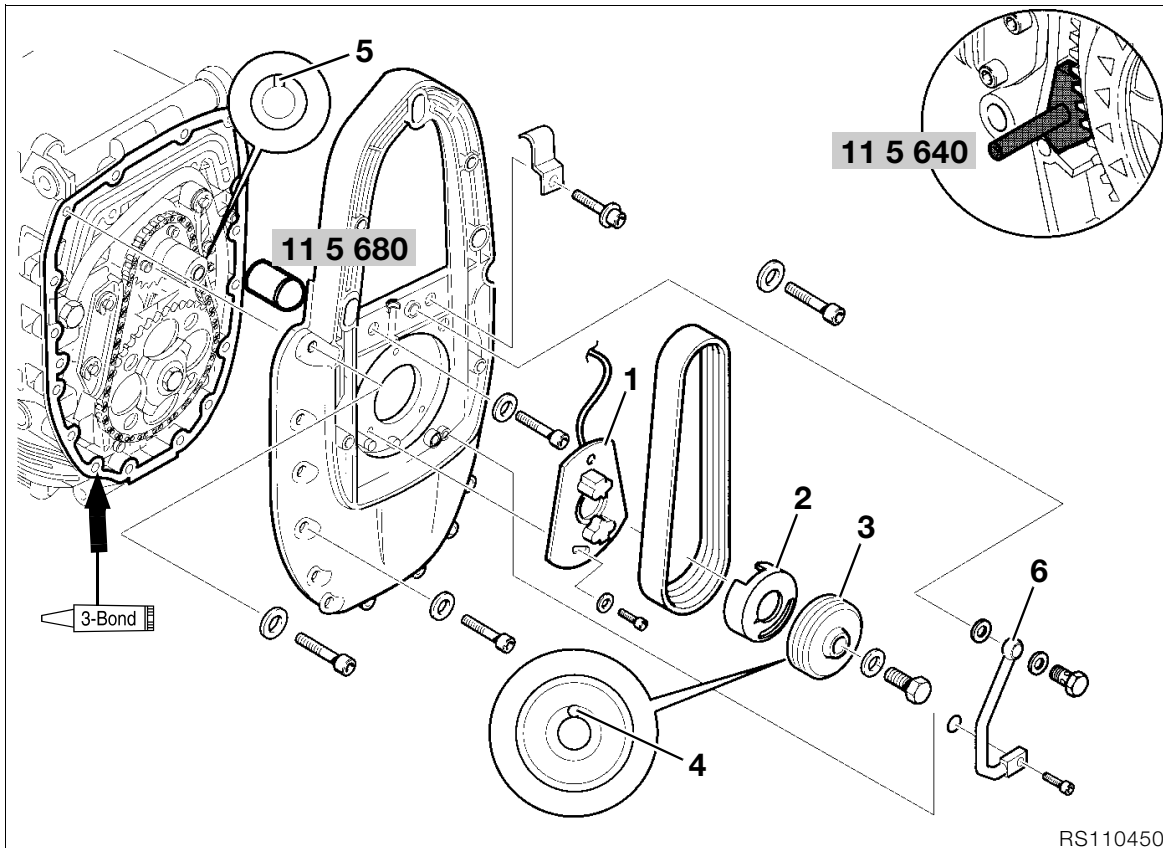

### Installing alternator mount cover

- Place sliding sleeve, **BMW No. 11 5 680**, on crankshaft.
- Apply **3-Bond 1209** to the sealing face (arrow), which must be clean and free from grease.
- Install alternator mount cover.

 **Tightening torque:**

M 8 screw .....	20 Nm
M 6 screw .....	9 Nm

### Installing magnetic gate/belt pulley

- Install Hall-effect trigger plate (1).
- Lock clutch housing with retaining device, **BMW No. 11 5 640**.
- **[from 1995 model year on]** Prevent rotor (2) of Hall-effect gate from moving with (for example) **Loctite instant adhesive** at Poly-V belt pulley (3).
- Install the Poly-V belt pulley.

 **Caution:**

Install the belt pulley lock (4) (from model year 1995 on, rotor location at Hall-effect gate) at the groove/crankshaft (5).

 **Tightening torque:**

Retaining screw for belt pulley ..... 50 Nm

- Install rotary breather pipe (3) with new sealing rings.

 **Tightening torque:**

Vent line to alternator mount cover  
M 8 screw ..... 20 Nm  
Banjo screw ..... 25 Nm

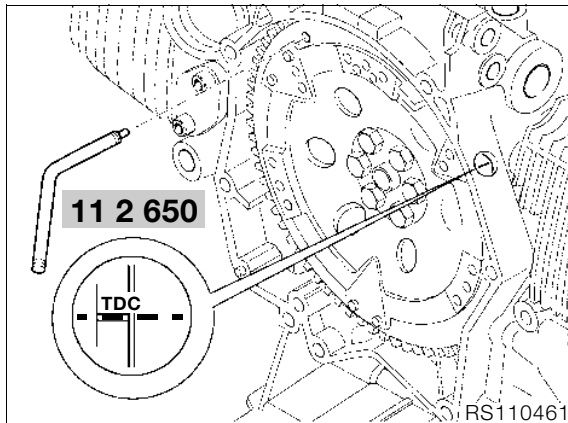

### Timing the ignition

- Prevent clutch housing from moving with TDC insert pin, **BMW No. 11 2 650**.

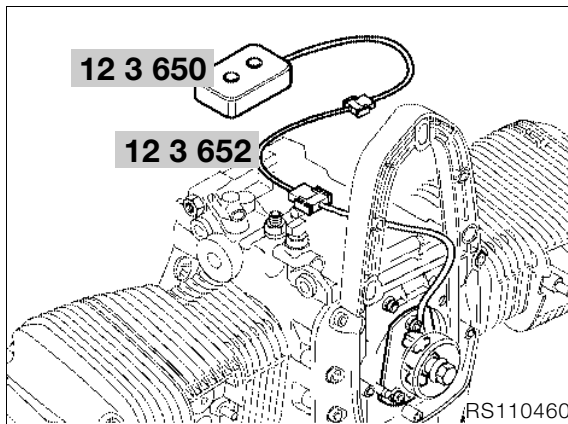

- Connect ignition tester, **BMW No. 12 3 650**, and adapter lead, **BMW No. 12 3 652**, to magnetic gate.
- Turn the Hall-effect gate plate until the telltale lamp just goes out.
- Tighten plate on Hall-effect trigger.
- Remove the TDC insert pin.

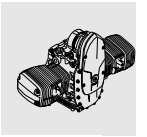

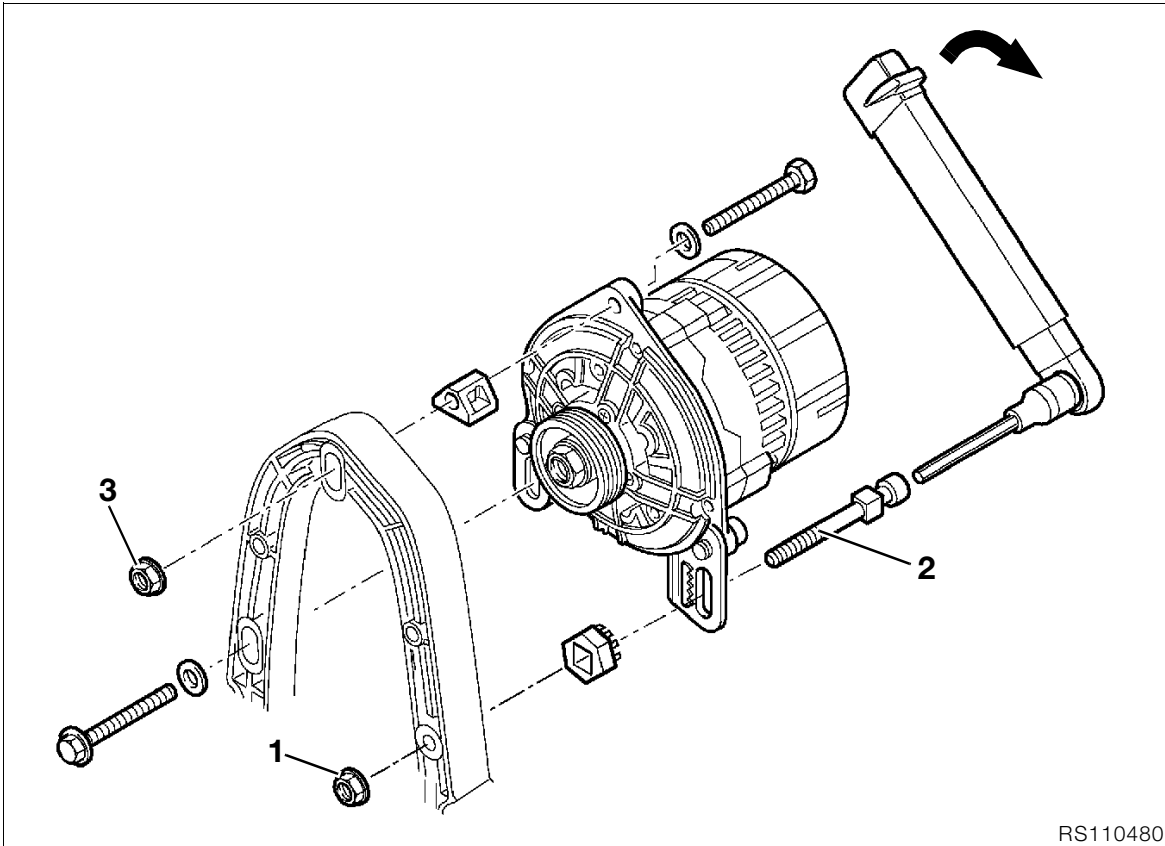
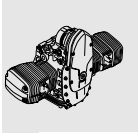

RS110480

### Installing alternator

- Install alternator.

#### Adjusting procedure for Poly-V belt:

Installation procedure for Poly-V belt:

- Place Poly-V belt in position, tension, turn the engine over once and relieve belt tension.

Poly-V belt tensioning procedure:

- Screw up hex nut (1) at adjusting screw (2) lightly by hand, **(using no tools)**.
- Tighten adjusting screw (2) with a torque wrench, fully tighten retaining nut (3), slacken adjusting screw and tighten screws fully.

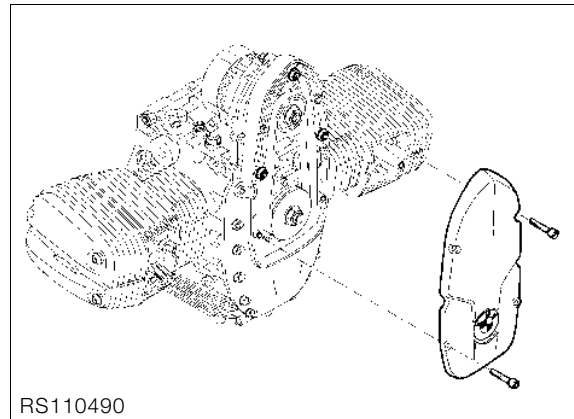

RS110490

#### **Tightening torque:**

Pre-tension Poly-V belt  
with adjusting screw..... 8 Nm  
Alternator to alternator support cover..... 20 Nm

- Install front cover.

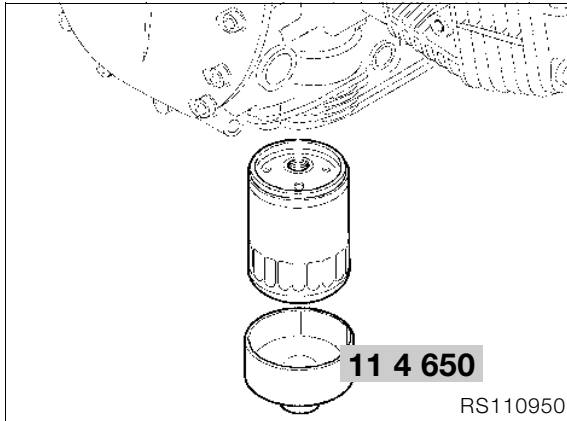

## Installing engine

- Work in reverse order to that stated for removal.

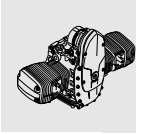

- Install oil filter with oil filter wrench, **BMW No. 11 4 650**.
- Insert and tighten oil drain plug with a new seal.

**! Tightening torque:**  
 Oil filter (sealing face lightly oiled) ..... 11 Nm  
 Oil drain plug ..... 32 Nm

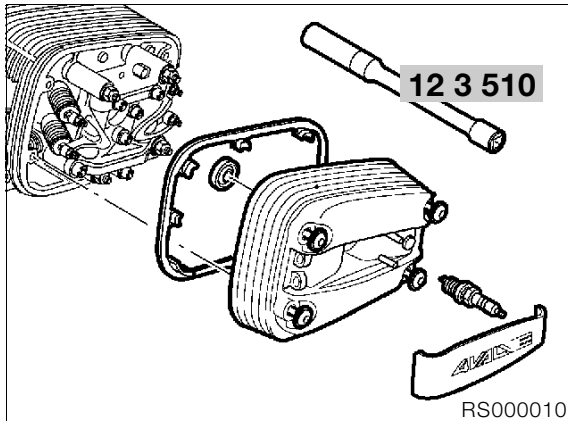

- Install spark plugs with spark plug wrench, **BMW No. 12 3 510**.

**! Tightening torque:**  
 Spark plug ..... 20 Nm

# 12 Engine electrics

Contents	Page
<b>Technical Data</b> .....	3
<b>Removing and installing coil and ignition lead</b> .....	7
Checking ignition coil resistance .....	7
<b>Removing and installing alternator</b> .....	8
Adjusting procedure for Poly-V belt: .....	9
<b>Dismantling/reassembling alternator</b> .....	10
Checking alternator .....	11
Checking armature for short to ground (earth) .....	11
<b>Removing and installing starter motor</b> .....	12
<b>Dismantling/reassembling starter motor</b> .....	13
Renewing carbon brushes .....	13
Checking starter motor .....	13
Checking starter relay .....	13
<b>Removing and installing magnetic gate</b> .....	14
Timing the ignition .....	15

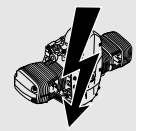



Technical Data		R 1100 RS
<b>Starter motor</b>		
Type	Permanent-magnet motor with planetary gear drive	
Gear ratio		Planetary gears 5,5 : 1
Power rating	kW	1,1
<b>Alternator</b>		
Type	Three-phase alternating-current generator with integrated all-electronic voltage regulator	
Drive		Poly-V belt
Gear ratios		1 : 1,5
Maximum output rating	W/V	700/14
Maximum current at engine speed 4000 min <sup>-1</sup>	A	50
Nominal current at engine speed 1000 min <sup>-1</sup>	A	18
Max. operating speed	min <sup>-1</sup>	20 000
Aluminum Poly-V belt pulley Extl. dia., measured at tips of teeth Wear dimension	mm (in)	
<b>Spark plug</b>		
Bosch		FR 6 DDC
Electrode gap	mm (in)	0,8 (0.0315)
Wear limit	mm (in)	1,0 (0.0394)
Thread	metric	M 14 x 1,25
<b>Ignition</b>		
Ignition system	Motronic (mapped characteristic control)	
Ignition trigger	Two magnetic gates (Hall-effect transmitters) driven from crankshaft	
Ignition timing	°KW	0° – + 43° before TDC
Static ignition timing	°KW	Adjustment at TDC
	Motronic converts TDC value into 6° before TDC	
<b>Ignition coil</b>		
Twin-spark coil		
Resistance: Primary, between terminals 15 and 1	Ω	~0,5
Secondary, between terminals 4a and 4b	kΩ	~13







Technical Data		R 1100 RT
<b>Starter motor</b>		
Type	Permanent-magnet motor with planetary gear drive	
Gear ratio		Planetary gears 5,5 : 1
Power rating	kW	1,1
<b>Alternator</b>		
Type	Three-phase alternating-current generator with integrated all-electronic voltage regulator	
Drive		Poly-V belt
Gear ratios		1 : 1,5
Maximum output rating	W/V	700/14
Maximum current at engine speed 4000 min <sup>-1</sup>	A	50
Nominal current at engine speed 1000 min <sup>-1</sup>	A	18
Max. operating speed	min <sup>-1</sup>	20 000
Aluminum Poly-V belt pulley Extl. dia., measured at tips of teeth Wear dimension	mm (in)	
<b>Spark plug</b>		
Bosch		FR 6 DDC
Electrode gap	mm (in)	0,8 (0.0315)
Wear limit	mm (in)	1,0 (0.0394)
Thread	metric	M 14 x 1,25
<b>Ignition</b>		
Ignition system	Motronic (mapped characteristic control)	
Ignition trigger	Two magnetic gates (Hall-effect transmitters) driven from crankshaft	
Ignition timing	°KW	0° – + 43° before TDC
Static ignition timing	°KW	Adjustment at TDC
		Motronic converts TDC value into 6° before TDC
<b>Ignition coil</b>		
Twin-spark coil		
Resistance: Primary, between terminals 15 and 1	Ω	~0,5
Secondary, between terminals 4a and 4b	kΩ	~13

Technical Data	R 850 GS	R 1100 GS
<b>Starter motor</b>		
Type	Permanent-magnet motor with planetary gear drive	
Gear ratio	Planetary gears 5,5 : 1	Planetary gears 5,5 : 1
Power rating	kW 1,1	1,1
<b>Alternator</b>		
Type	Three-phase alternating-current generator with integrated all-electronic voltage regulator	
Drive	Poly-V belt	Poly-V belt
Gear ratios	1 : 1,5	1 : 1,5
Maximum output rating	W/V 700/14	700/14
Maximum current at engine speed 4000 min <sup>-1</sup>	A 50	50
Nominal current at engine speed 1000 min <sup>-1</sup>	A 18	18
Max. operating speed	min <sup>-1</sup> 20 000	20 000
Aluminum Poly-V belt pulley Extl. dia., measured at tips of teeth Wear dimension	mm (in)	55,5 (2.185)
<b>Spark plug</b>		
Bosch	FR 6 DDC	FR 6 DDC
Electrode gap	mm (in) 0,8 (0.0315)	0,8 (0.0315)
Wear limit	mm (in) 1,0 (0.0394)	1,0 (0.0394)
Thread	metric M 14 x 1,25	M 14 x 1,25
<b>Ignition</b>		
Ignition system	Motronic (mapped characteristic control)	
Ignition trigger	Two magnetic gates (Hall-effect transmitters) driven from crankshaft	
Ignition timing	°KW 0° – + 43° before TDC	0° – + 43° before TDC
Static ignition timing	°KW Adjustment at TDC	Adjustment at TDC
	Motronic converts TDC value to 6° before TDC	
<b>Ignition coil</b>		
Twin-spark coil		
Resistance: Primary, between terminals 15 and 1	Ω ~0,5	~0,5
Secondary, between terminals 4a and 4b	kΩ ~13	~13





Technical Data		R 850 R	R 1100 R
<b>Starter motor</b>			
Type		Permanent-magnet motor with planetary gear drive	
Gear ratio		Planetary gears 5,5 : 1	Planetary gears 5,5 : 1
Power rating	kW	1,1	1,1
<b>Alternator</b>			
Type		Three-phase alternating-current generator with integrated all-electronic voltage regulator	
Drive		Poly-V belt	Poly-V belt
Gear ratios		1 : 1,5	1 : 1,5
Maximum output rating	W/V	700/14	700/14
Maximum current at engine speed 4000 min <sup>-1</sup>	A	50	50
Nominal current at engine speed 1000 min <sup>-1</sup>	A	18	18
Max. operating speed	min <sup>-1</sup>	20 000	20 000
Aluminum Poly-V belt pulley Extl. dia., measured at tips of teeth Wear dimension	mm (in)	55,5 (2.185)	55,5 (2.185)
<b>Spark plug</b>			
Bosch		FR 6 DDC	FR 6 DDC
Electrode gap	mm (in)	0,8 (0.0315)	0,8 (0.0315)
Wear limit	mm (in)	1,0 (0.0394)	1,0 (0.0394)
Thread	metric	M 14 x 1,25	M 14 x 1,25
<b>Ignition</b>			
Ignition system		Motronic (mapped characteristic control)	
Ignition trigger		Two magnetic gates (Hall-effect transmitters) driven from crankshaft	
Ignition timing	°KW	0° – + 43° before TDC	0° – + 43° before TDC
Static ignition timing	°KW	Adjustment at TDC	Adjustment at TDC
		Motronic converts TDC value to 6° before TDC	
<b>Ignition coil</b>			
Twin-spark coil			
Resistance: Primary, between terminals 15 and 1	Ω	~0,5	~0,5
Secondary, between terminals 4a and 4b	kΩ	~13	~13

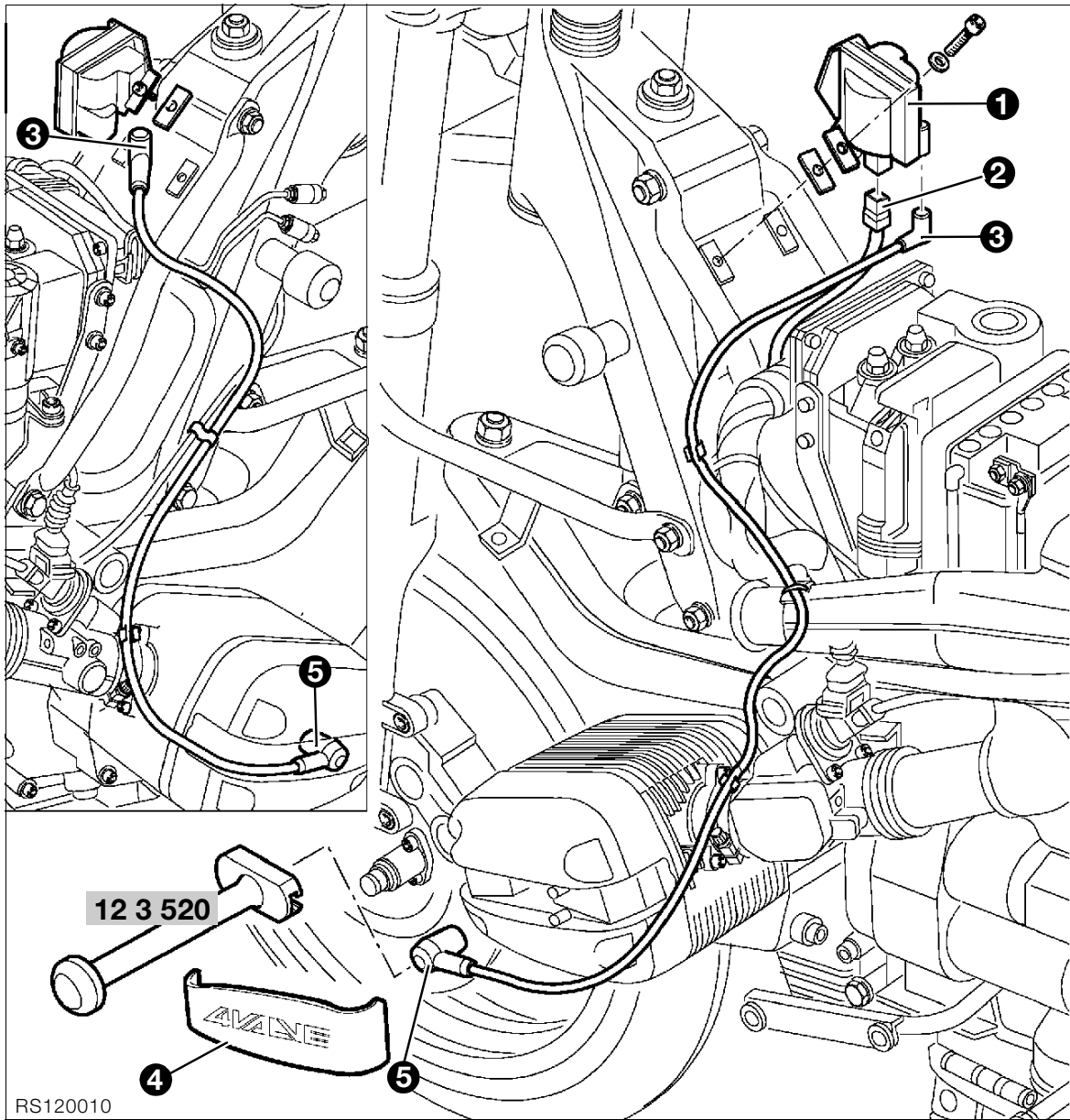

## Removing and installing coil and ignition lead

- Remove dualseat.
- **[RS/GS/RT]** Remove side sections of fairing.
- **[RS]** Remove inner fairing panel at fuel tank.
- **[R]** Remove tank cover.
- Unscrew fuel tank mount.
- Seal, loosen and pull off fuel feed and return line with hose clip **BMW No. 13 0 010**.
- Remove vent pipes.
- Separate plug for fuel pump.
- Remove fuel tank.

### Caution:

Switch off ignition. Disconnect ground (earth) cable at battery and insulate it.

- **[GS/R]** Detach Motronic control unit and pull it out upwards.
- Remove ignition coil (1).
- Separate plug connector (2).
- Pull off ignition lead (3).
- Remove spark plug cover (4).
- Remove plug cap (5) with puller, **BMW No. 12 3 520**.
- Remove ignition lead.
- Install in the reverse order of work.

## Checking ignition coil resistance

➡ See Technical Data.

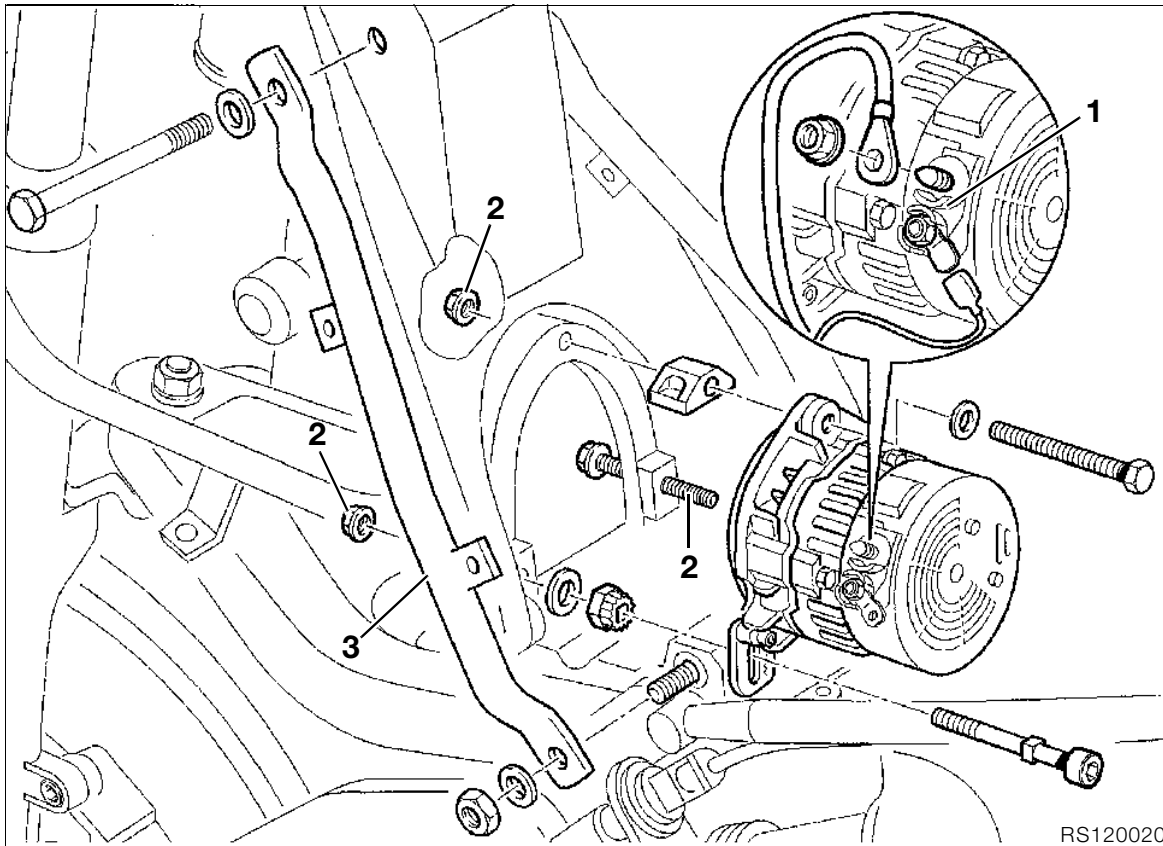

## Removing and installing alternator

- Remove dualseat.
- **[RS/GS/RT]** Remove side sections of fairing.



### Caution:

Disconnect ground (earth) lead from battery. Insulate ground (earth) lead.

- **[RS]** Remove inner fairing panel at fuel tank.
- **[R]** Remove fuel tank cover.
- Unscrew fuel tank mount.
- Seal, loosen and pull off fuel feed and return line with hose clip, **BMW No. 13 0 010**.
- Remove vent pipes.
- Separate plug for fuel pump.
- Remove fuel tank.

- Remove Motronic control unit.
- **[ABS]** - detach pressure modulator.
- Remove front cover from engine.
- Detach connecting leads (1) from alternator.
- Loosen Poly-V belt pulley at alternator.
- Unscrew alternator mount (2).
- Take off Poly-V belt pulley and belt.
- Remove strut (3) from frame at left.
- Remove alternator.



### Caution:

Do not scratch other parts; disconnect if necessary.

- Install in the reverse order of work.

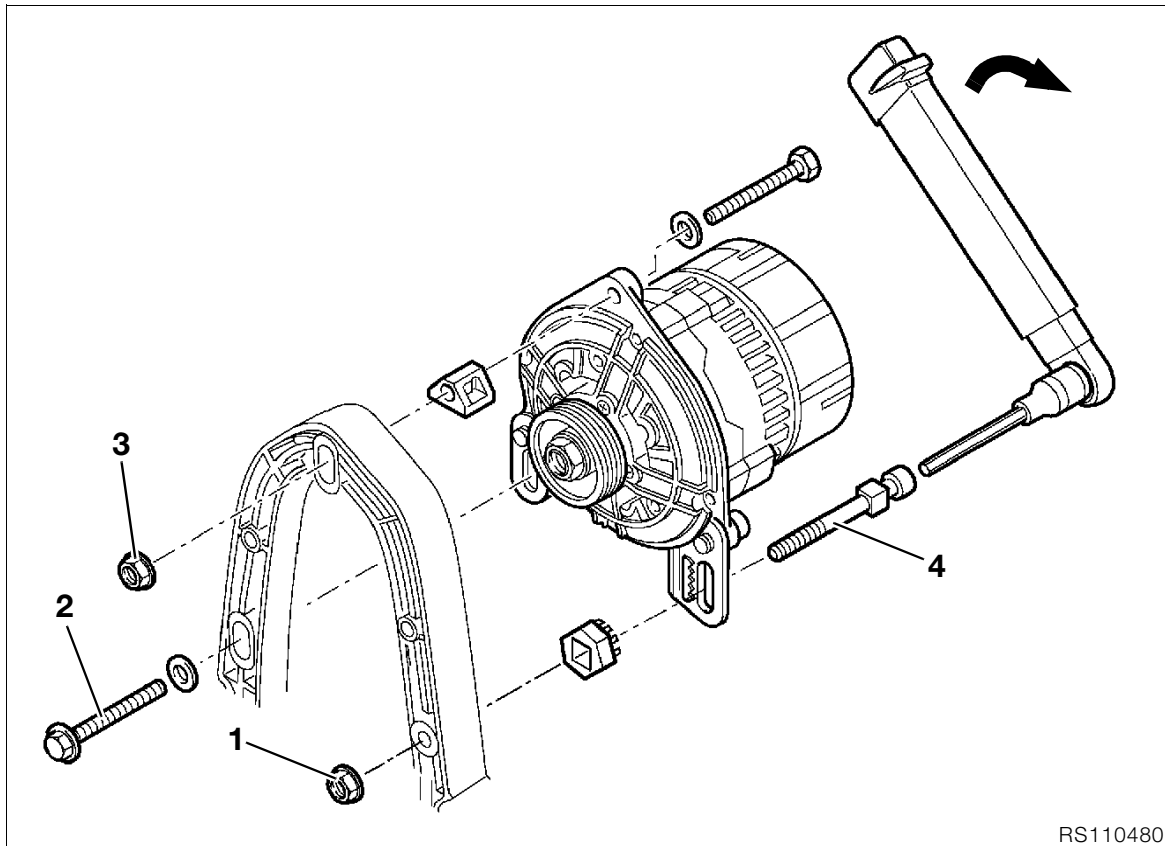

**Adjusting procedure for Poly-V belt:**

Poly-V belt installation procedure:

- Place the Poly-V belt in position, tension it, turn the engine over once, then relieve belt tension

Poly-V belt tensioning procedure:

- Loosen alternator mount (1, 2, 3).
- Screw up hex nut (1) at adjusting screw (4) lightly by hand (**using no tools**)
- Tighten adjusting screw (4) using torque wrench; fully tighten retaining nut (3), slacken off adjusting screw and tighten down screws.



**Note:**

Siehe auch Serviceinformation 12 020 95 (700).



**Tightening torque:**

Poly-V belt preload.....	8 Nm
Alternator to alternator support cover.....	20 Nm
Positive lead to alternator.....	15 Nm
Belt pulley at alternator.....	50 Nm



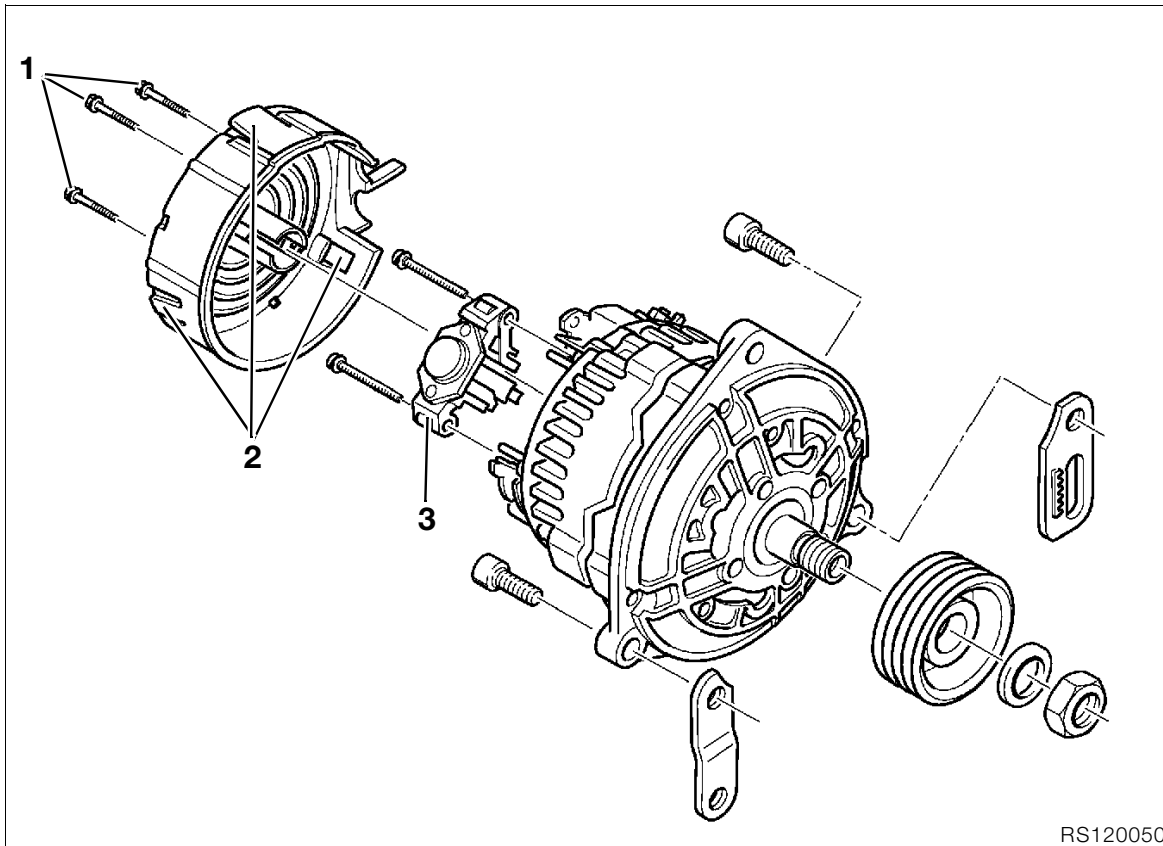

## Dismantling/reassembling alternator

- Take out the cover retaining screws (1).
- Release clips (2) and remove the cover.
- Remove voltage regulator (3).
- Remove the Poly-V belt pulley.
- Install in the reverse order of work.

 **Tightening torque:**  
 Belt pulley at alternator..... 50 Nm

## Checking alternator



### Note:

Before each  $\Omega$  measurement, calibrate to zero with the BMW diagnosis tester:  
Connect the positive (yellow) and negative (green) leads together.  $\Omega$ -key is to be pressed until the digital display reads 0.00  $\Omega$ .

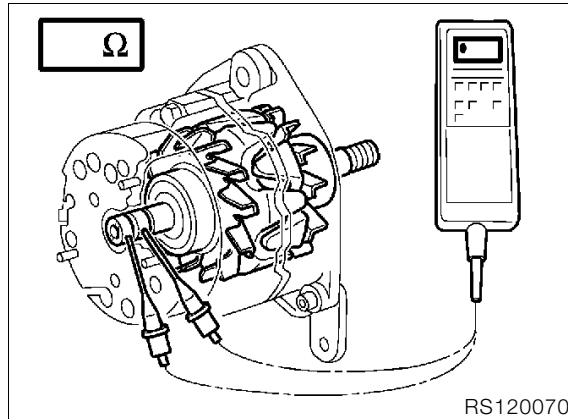

- Using BMW Diagnosis tester, **BMW No. 61 1 510**, measure resistance between the sliprings.

**Nominal resistance:**..... 3  $\Omega$

Checking armature for short to ground (earth)

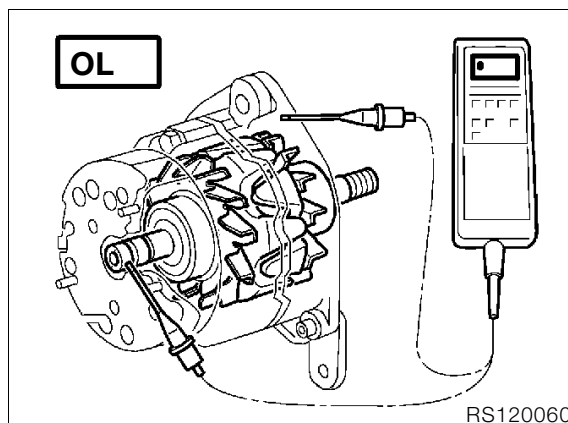

- Measure resistance between sliprings and armature

**Measured result:**..... OL = open line





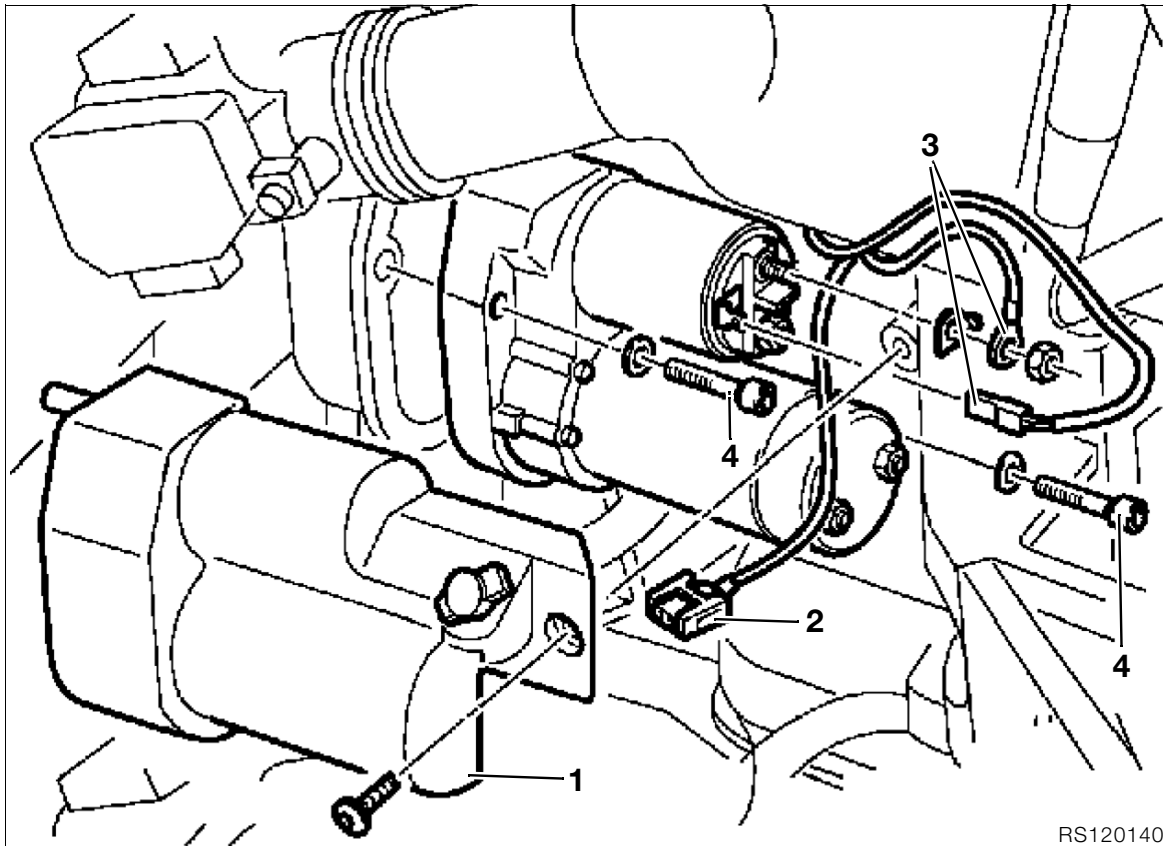

RS120140

## Removing and installing starter motor

- Remove dualseat.
- **[RS/RT]** Remove left side section of fairing.



### Caution:

Disconnect ground (earth) lead from battery. Insulate ground (earth) lead.

- **[RS/GS/R]** Remove cover (1) for starter motor and pull off wire (2) for power socket.
- Detach connecting lead (3).
- Take out retaining screws (4) and remove the starter motor.
- Install in the reverse order of work.



### Tightening torque:

Starter motor to engine ..... 20 Nm  
 Starter motor cover to gearbox housing ..... 7 Nm  
 Positive lead to starter motor..... 10 Nm

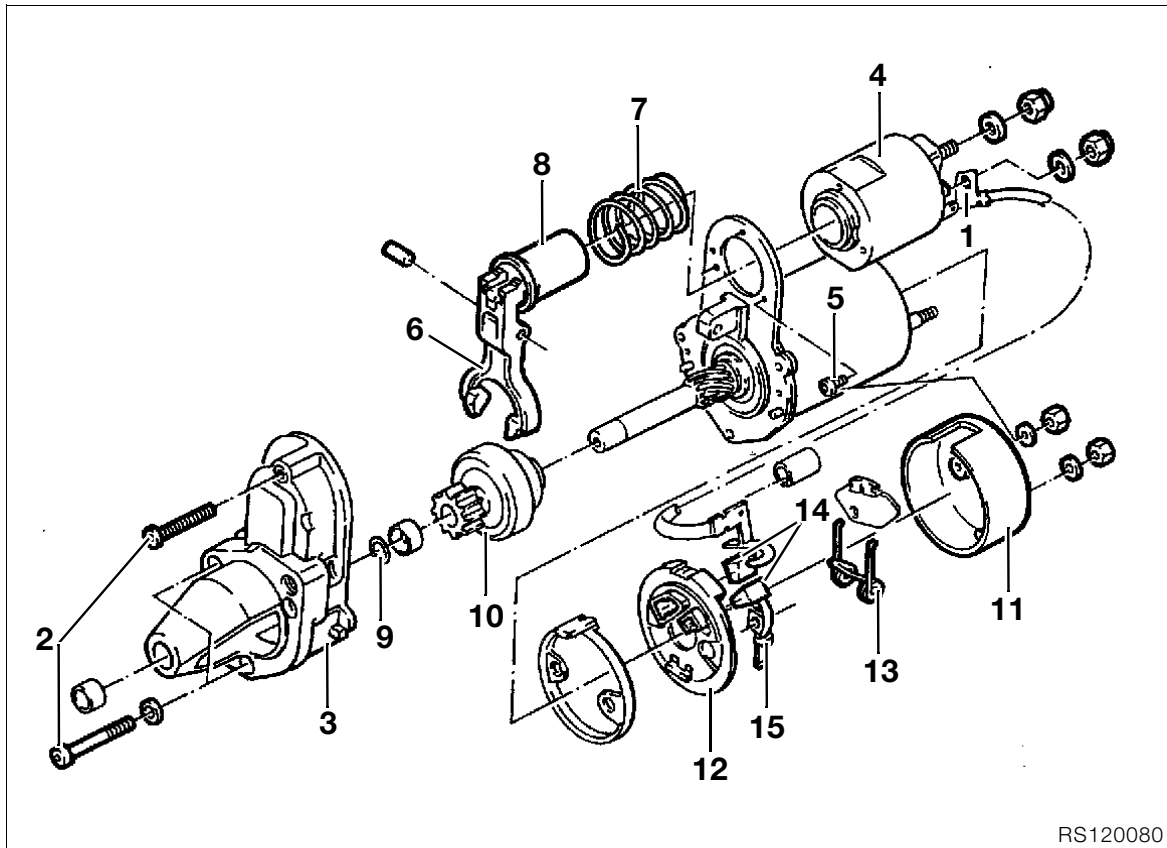

RS120080

## Dismantling/reassembling starter motor

- Detach lead (1).
- Remove retaining screws (2).
- Remove flange (3).
- Remove solenoid switch (4) after taking out the retaining screws (5).
- Remove release lever (6) and spring (7) from solenoid switch (8).
- Remove retaining ring (9) and take starter motor gear assembly (10) off shaft.
- Install in the reverse order of work.
- Coat the steep-angle thread and the engaging ring with **Bosch PZ 2 V 3 silicone grease**.

## Renewing carbon brushes

- Detach lead (1).
- Remove cover (11).
- Remove holder (12) for carbon brushes.
- Lift up retaining springs (13) and remove carbon brushes (14).
- Install carbon brushes with retaining plate.
- Slide short lead (15) on to threaded pin.
- Install cover (11).
- Attach lead (1).

## Checking starter motor

Engine temperature > 20 °C

- Ammeter in positive lead to starter motor.

### Starter is in good working order at:

.....app. 80...150 A

- Voltmeter connected to (+) and (-) on starter motor

### Starter is in good working order at:

.....app. 10...11 V

## Checking starter relay



### Note:

Before each  $\Omega$  measurement, calibrate to zero with the BMW diagnosis tester:  
Connect the positive (yellow) and negative (green) leads. Press the  $\Omega$  key until the digital display reads 0.00  $\Omega$ .

- After calibration, insert the  $\Omega$  meter between terminals 30 and 87.

$\Omega$  value .....0  $\Omega$

- Connect positive supply to terminal 85 and negative supply to terminal 86. Then:  
Connect (+) to terminal 85, (-) to terminal 86b.

The relay must be energized.

$\Omega$  value: ..... 0  $\Omega$

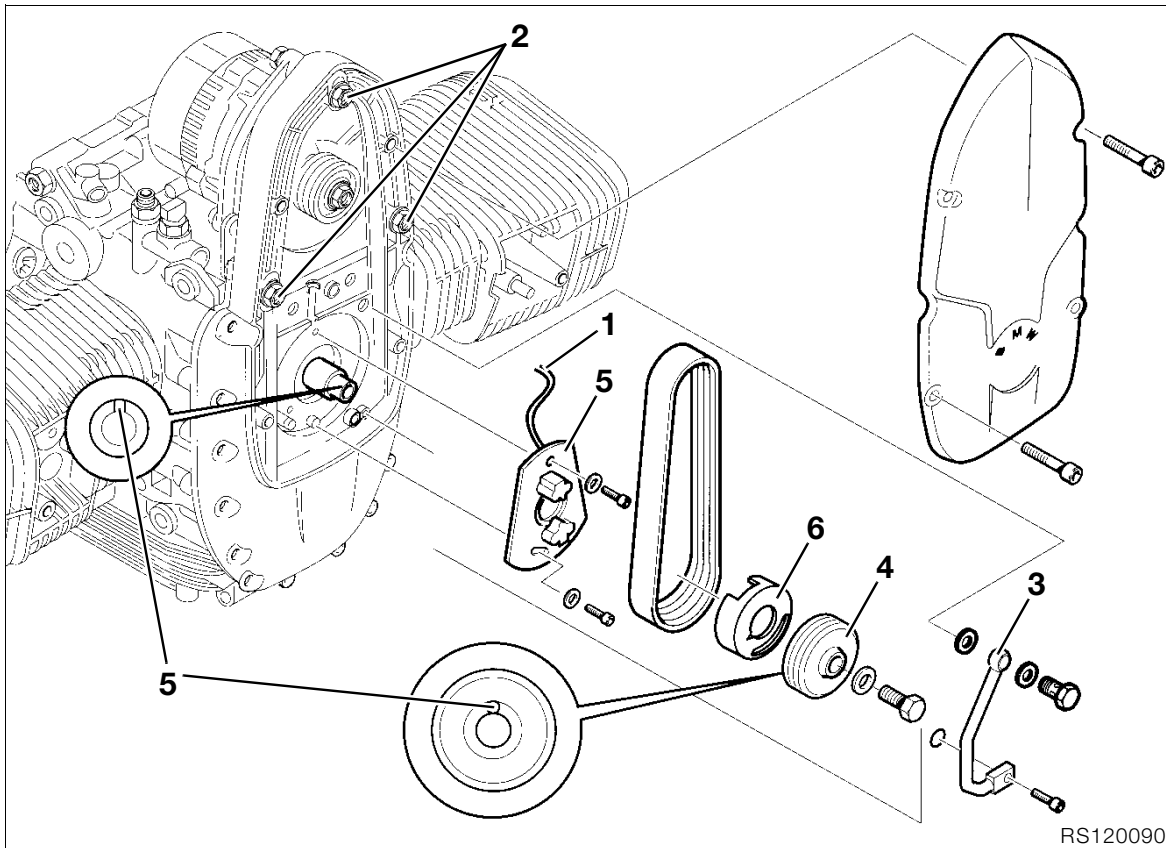

RS120090

## Removing and installing magnetic gate

- Remove dualseat.
- **[RS/GS/RT]** Remove side sections of fairing.
- **[RS]** Remove inner fairing panel at fuel tank.
- **[R]** Remove tank cover.
- Unscrew fuel tank mount and carefully move the tank to the rear.



### Caution:

Do not scratch paint; place foam rubber mat or similar item under tank.

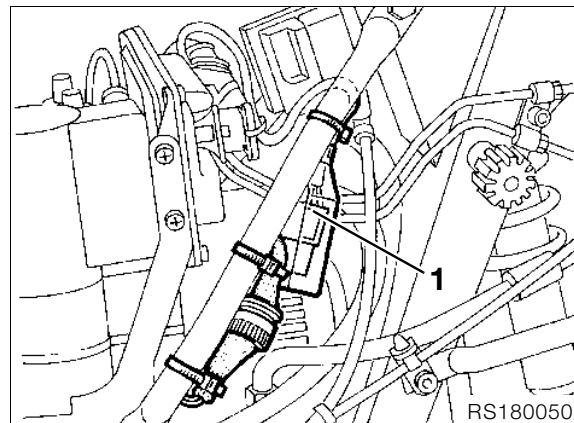

RS180050



### Caution:

Disconnect ground (earth) lead from battery. Insulate the ground (earth) lead!

- Separate plug connection (1) for magnetic trigger.
- Remove front cover from engine.
- Slacken off alternator mount (2) and relieve tension on Poly-V belt.
- **[RS/GS/R]** Remove starter motor cover/pull off power socket lead.
- Remove starter motor.
- Lock clutch housing with retaining device, **BMW No. 11 5 640.**

- Remove rotary breather pipe (3).
- Remove pulley (4).



**Note:**

Ggf. Einbaulage der Magnetschranke für Wiedereinbau kennzeichnen.

- Remove magnetic trigger (5).
- Install in reverse order of work.
- **[from 1995 model year on]** Secure rotor (6) of Hall-effect gate with **Loctite instant adhesive** or similar to the Poly-V belt.



**Caution:**

Install lock (7) for belt pulley **[from 1995 model year on]** location at Hall-effect gate rotor] in groove/crankshaft (7). Carefully dismantle magnetic trigger lead. Tension Poly-V belt according to installation procedure.



**Tightening torque:**

Pre-tension of Poly-V belt ..... 8 Nm  
 Alternator to alternator mount cover ..... 20 Nm  
 Belt pulley to crankshaft ..... 50 Nm

Timing the ignition

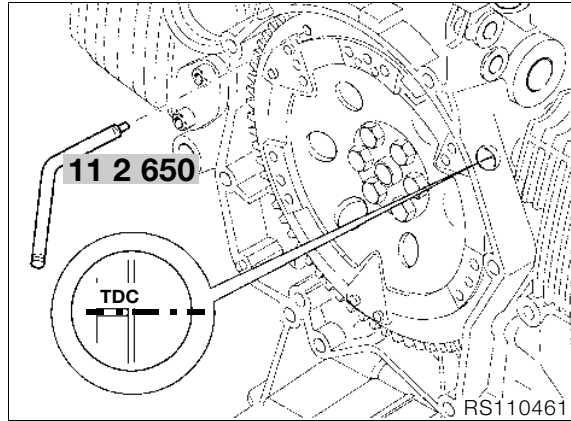

- Lock the clutch housing with the TDC insert pin, **BMW No. 11 2 650**.

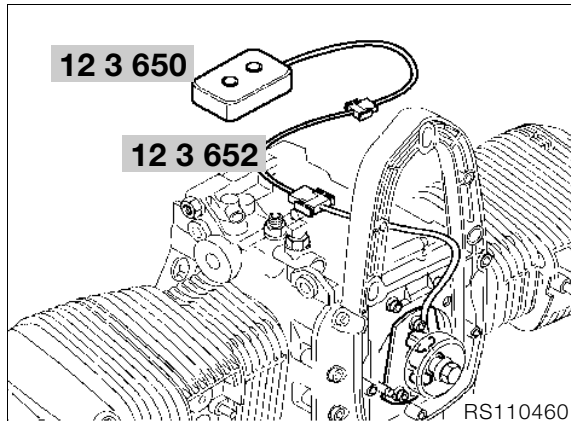

- Connect ignition tester, **BMW No. 12 3 650**, and adapter lead, **BMW No. 12 3 652**, to Hall-effect trigger plate.
- Slacken off plate of Hall-effect trigger.
- Turn plate until telltale lamp just goes out.
- Tighten plate on Hall-effect trigger.
- Remove OT (TDC) insert pin.

# 13 Fuel preparation and control

<b>Contents</b>	Page
<b>Technical Data</b> .....	3
<b>Removing and installing air cleaner</b> .....	7
<b>Removing and installing throttle stub pipe</b> .....	8
Removing and installing injectors .....	9
<b>Removing and installing Motronic control unit</b> .....	9

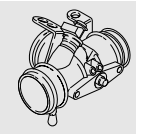

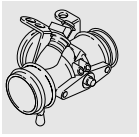

Technical Data		R 1100 RS
Fuel grade		Super (premium), unleaded, 95 octane (RON)
Mixture preparation		Motronic MA 2.2
Throttle stub pipe intl. dia.	mm (in)	45 (1.772)
Throttle angle in rest position	°	10
Air cleaner		Circular paper element

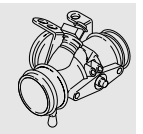

Technical Data		R 1100 RT
Fuel grade		Super (premium), unleaded, 95 octane (RON)
Mixture preparation		Motronic MA 2.2
Throttle stub pipe intl. dia.	mm (in)	45 (1.772)
Throttle angle in rest position	°	10
Air cleaner		Circular paper element

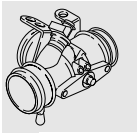



Technical Data	R 850 GS	R 1100 GS
Fuel grade	Super (premium), unleaded, 95 octane (RON)	Super (premium), unleaded, 95 octane (RON)
Mixture preparation	Motronic MA 2.2	Motronic MA 2.2
Throttle stub pipe intl. dia.	mm (in) 45 (1.772)	45 (1.772)
Throttle angle in rest position	° 10	10
Air cleaner	Circular paper element	Circular paper element

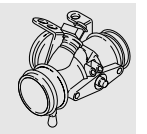

Technical Data	R 850 R	R 1100 R
Fuel grade	Super (premium), unleaded, 95 octane (RON)	Super (premium), unleaded, 95 octane (RON)
Mixture preparation	Motronic MA 2.2	Motronic MA 2.2
Throttle stub pipe intl. dia.	mm (in) 45 (1.772)	45 (1.772)
Throttle angle in rest position	° 10	10
Air cleaner	Circular paper element	Circular paper element



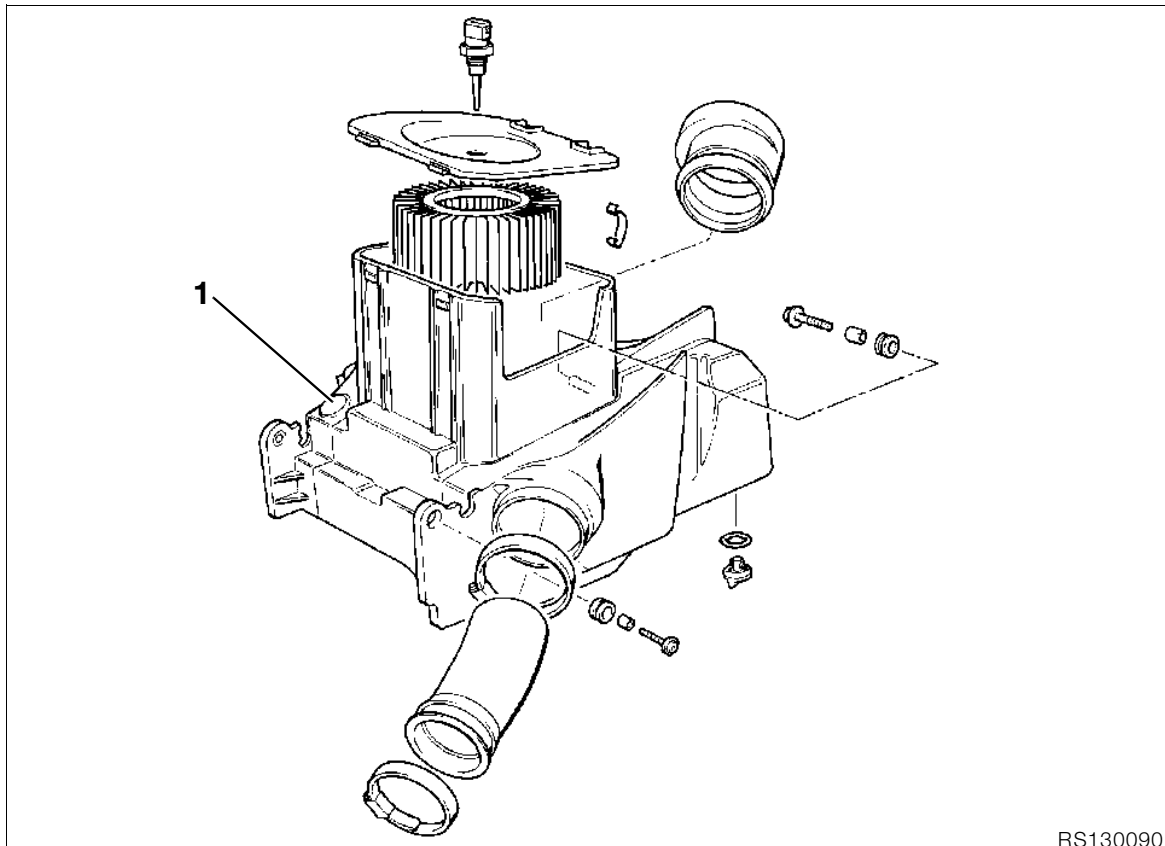

RS130090

## Removing and installing air cleaner

- Remove dualseat.
- **[RS/GS/RT]** Remove side sections of fairing.
- **[R]** Remove the tank cover.
- Remove fuel tank.
- Remove plug from air temperature sensor.
- Remove air cleaner cover.
- Remove air intake pipe.
- Remove brake fluid reservoir from holder.
- Remove rear brake pipe from holder.
- Disconnect plug for brake light switch and detach lead.
- Remove front/rear air cleaner box.
- Remove cable connector/wiring harness from air cleaner box.
- Separate connector between neutral switch and side stand switch and detach lead.
- Unfasten intake pipe from throttle body.
- Motorcycles with throttle-cable divider: disengage throttle cables.
- Remove rear muffler (silencer).
- **[ABS]** Detach brake caliper.
- **[ABS]/[GS/R/RT]** Detach ABS sensor.
- Remove rear wheel.
- Remove suspension strut.

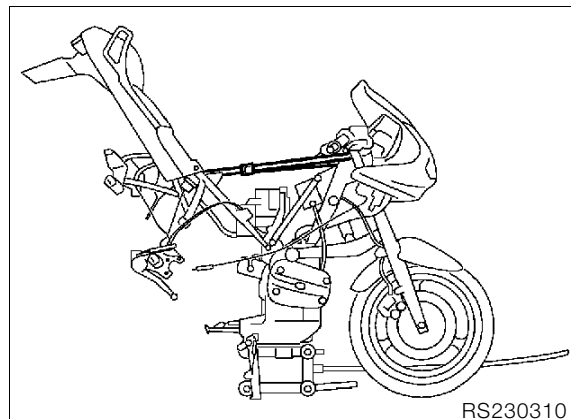

RS230310

- Tilt rear frame upwards and secure with strap.
- Detach return pipe from oil trap at air cleaner box (1).
- Remove air cleaner box.
- Install in the reverse order of work.



### Caution:

Place support under rear wheel drive.

- Unfasten screw connection on rear frame/only loosen mount at front of struts.

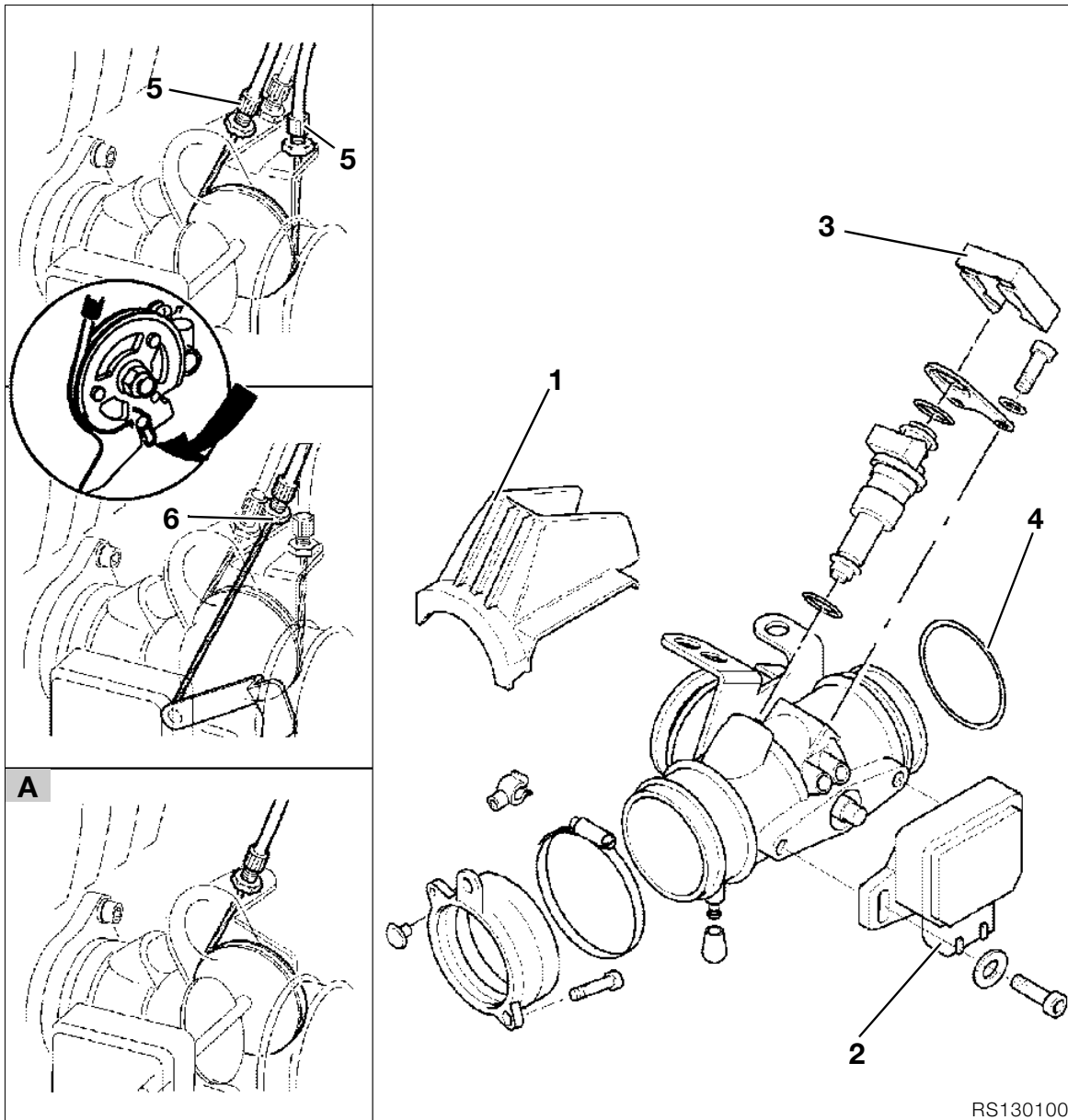

RS130100

## Removing and installing throttle stub pipe

- Remove cover (1).
- Press in the spring catch on the multi-pin plug at the throttle position sensor (2) and pull off the plug.



### Note:

Do not remove the throttle position sensor unless it has to be renewed (basic adjustment necessary – see Motronic diagnosis instructions).

- Unfasten retainer (3) for fuel pipe and pull off the pipe.
- Slacken off hose clips.
- Slide intake connection into air cleaner box and remove throttle body.



### Caution:

Make sure that the O-ring (4) at the throttle stub pipe is in good condition

- Disconnect throttle cable (5) from the right, then from the left, throttle body.
- Motorcycle with throttle-cable divider.
- ➔ Figure (A)
- Disconnect cable (6) for choke.
- Install in the reverse order of work

Adjusting choke, idle speed and synchronization

➔ See Group 00

## Removing and installing injectors

- Unfasten retainer (3) for fuel pipe and pull off the pipe.
- Press in the spring catch at the injector plug (5) and pull off the plug.
- Remove injector.



### Caution:

Make sure that O-rings at injector are in good condition.

- Install in the reverse order of work.

## Removing and installing Motronic control unit

- Remove fuel tank.



### Caution:

Switch off ignition; disconnect ground (earth) lead at battery and insulate it.

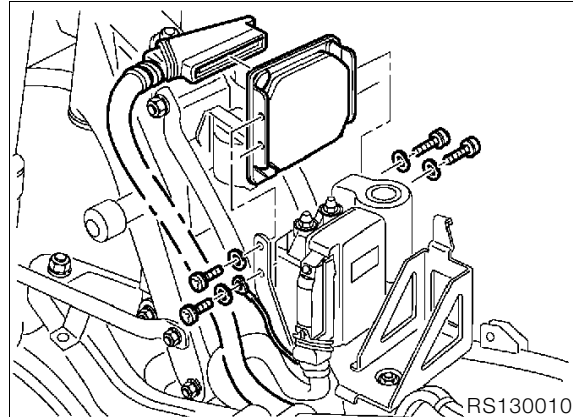

- Remove Motronic control unit.
- Remove connector strip.
- Install in the reverse order of work.

# 16 Fuel tank and lines

<b>Contents</b>	Page
<b>Technical Data</b> .....	3
<b>Removing and installing fuel tank</b> .....	7
<b>Removing and installing fuel filter, fuel pump and fuel level sensor</b> .....	9
Removing and installing fuel filter .....	10
Removing and installing fuel pump and fuel level sensor .....	10
Checking fuel pump pressure .....	11
<b>Removing and installing fuel distributor and pressure regulator</b> .....	11





Technical Data		R 1100 RS
<b>Fuel tank</b>		
Tank capacity	l (Imp. pints)	23 (40.48)
including reserve of	l (Imp. pints)	6 (10.56)
<b>Fuel pump</b>		
Type		Gear-type
Make		VDO
Operating voltage	V	12
Fuel pressure	bar (psi)	3 (43.512)
Delivery volume	l/h (Imp. pints/h)	110 (193.6)





Technical Data		R 1100 RT
<b>Fuel tank</b>		
Tank capacity	l (Imp. pints)	26 (45.75)
including reserve of	l (Imp. pints)	6 (10.56)
<b>Fuel pump</b>		
Type		Gear-type
Make		VDO
Operating voltage	V	12
Fuel pressure	bar (psi)	3 (43.512)
Delivery volume	l/h (Imp. pints/h)	110 (193.6)



Technical Data		R 850 GS	R 1100 GS
<b>Fuel tank</b>			
Tank capacity	l (Imp. pints)	25 (44)	25 (44)
including reserve of	l (Imp. pints)	6 (10.56)	6 (10.56)
<b>Fuel pump</b>			
Type		Gear-type	Gear-type
Make		VDO	VDO
Operating voltage	V	12	12
Fuel pressure	bar (psi)	3 (43.512)	3 (43.512)
Delivery volume	l/h (Imp. pints/h)	110 (193.6)	110 (193.6)



Technical Data		R 850 R	R 1100 R
<b>Fuel tank</b>			
Tank capacity	l (Imp. pints)	21 (36.96)	21 (36.95)
including reserve of	l (Imp. pints)	6 (10.56)	6 (10.56)
<b>Fuel pump</b>			
Type		Gear-type	Gear-type
Make		VDO	VDO
Operating voltage	V	12	12
Fuel pressure	bar (psi)	3 (43.512)	3 (43.512)
Delivery volume	l/h (Imp. pints/h)	110 (193.6)	110 (193.6)



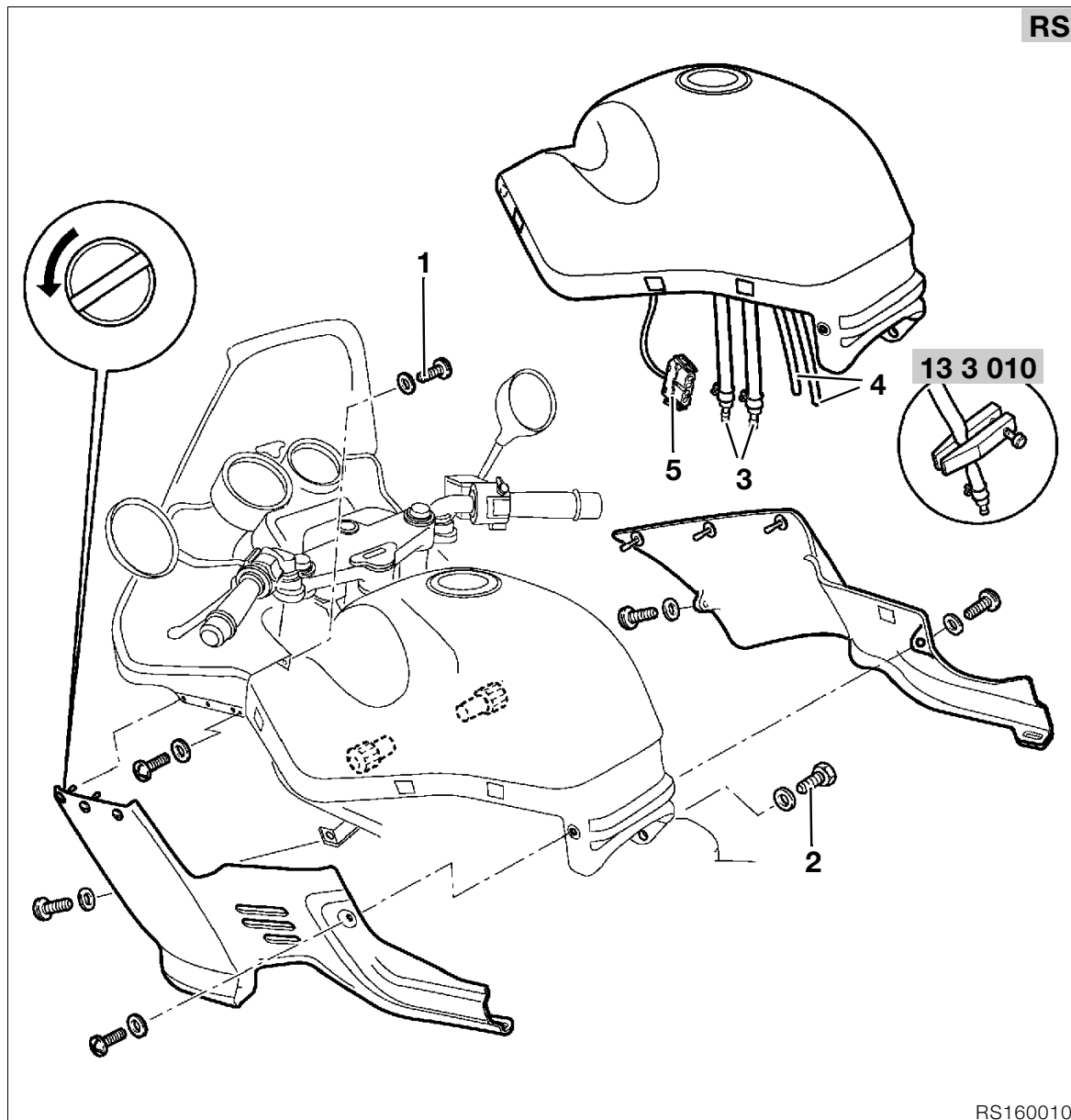

## Removing and installing fuel tank

- Remove dualseat.
- **[RS/GS/RT]** Remove side sections of fairing.
- **[RS]** Detach inner cockpit panel (1) at fuel tank.
- **[R]** Remove fuel tank cover.
- Remove fuel tank retaining screw (2).
- Seal, loosen and pull off fuel feed and return line (3) with hose clip, **BMW No. 13 3 010**.
- Remove vent pipes (4).
- Separate plug pipe connector (5) for fuel pump.
- Lift off fuel tank.
- Install in the reverse order of work.

**Tightening torque:**  
 Fuel tank to rear frame ..... 22 Nm

RT

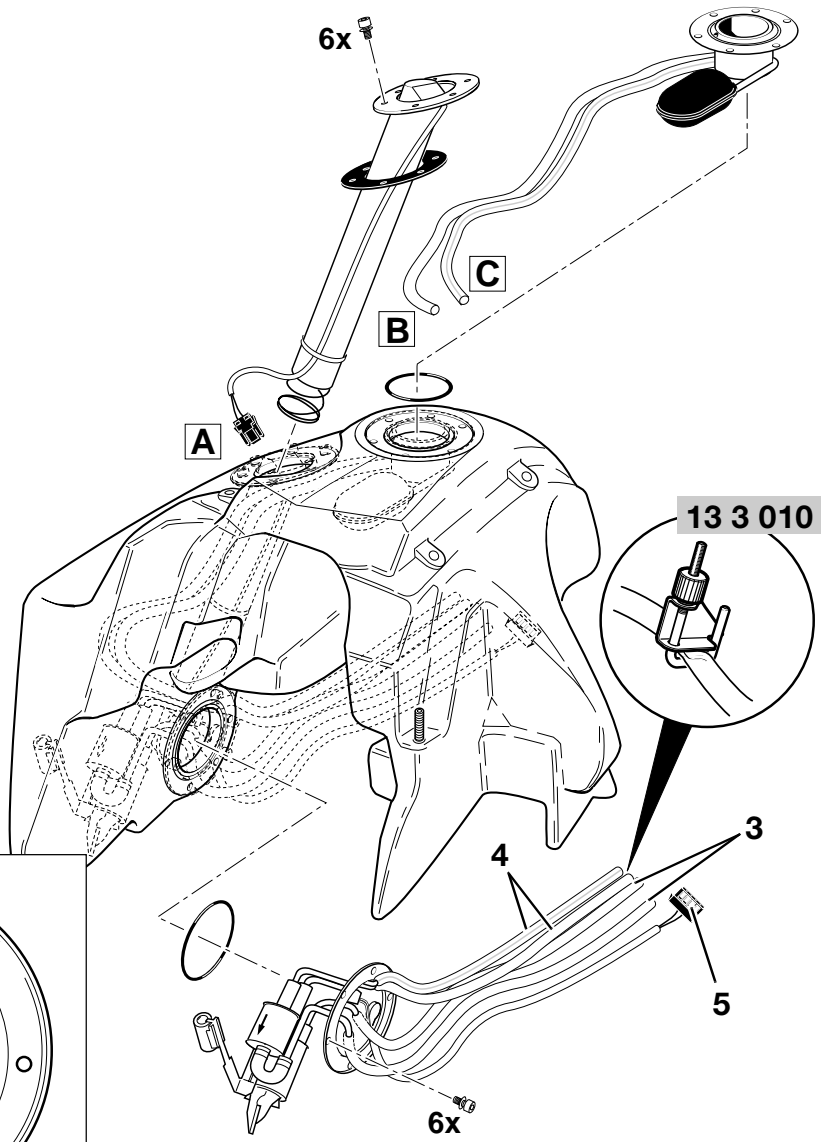
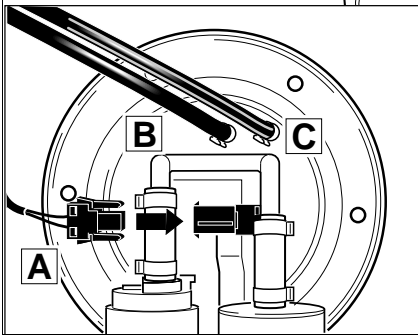

RT160060

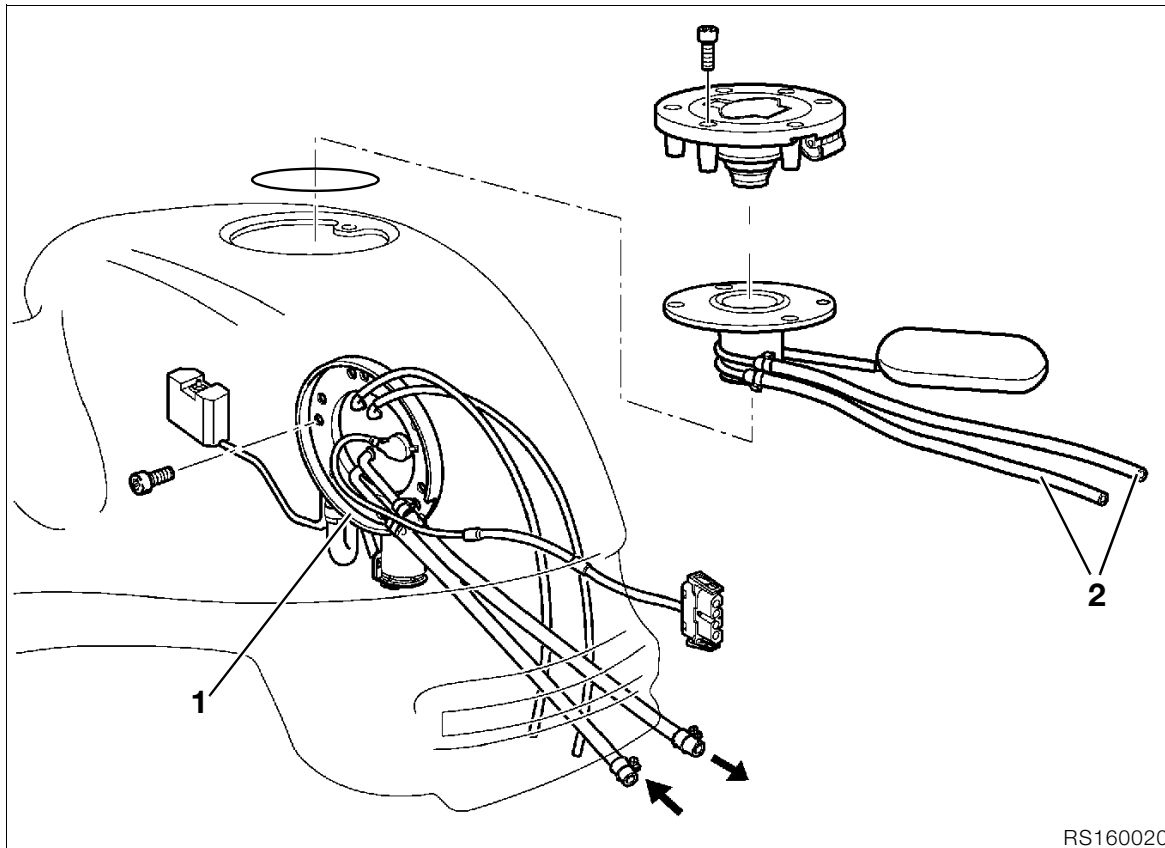

RS160020



## Removing and installing fuel filter, fuel pump and fuel level sensor



### Caution:

Fuel is flammable and a hazard to health.  
Observe relevant safety regulations.

- Drain fuel tank.
- Remove fuel pump unit (1) and detach hoses (2).

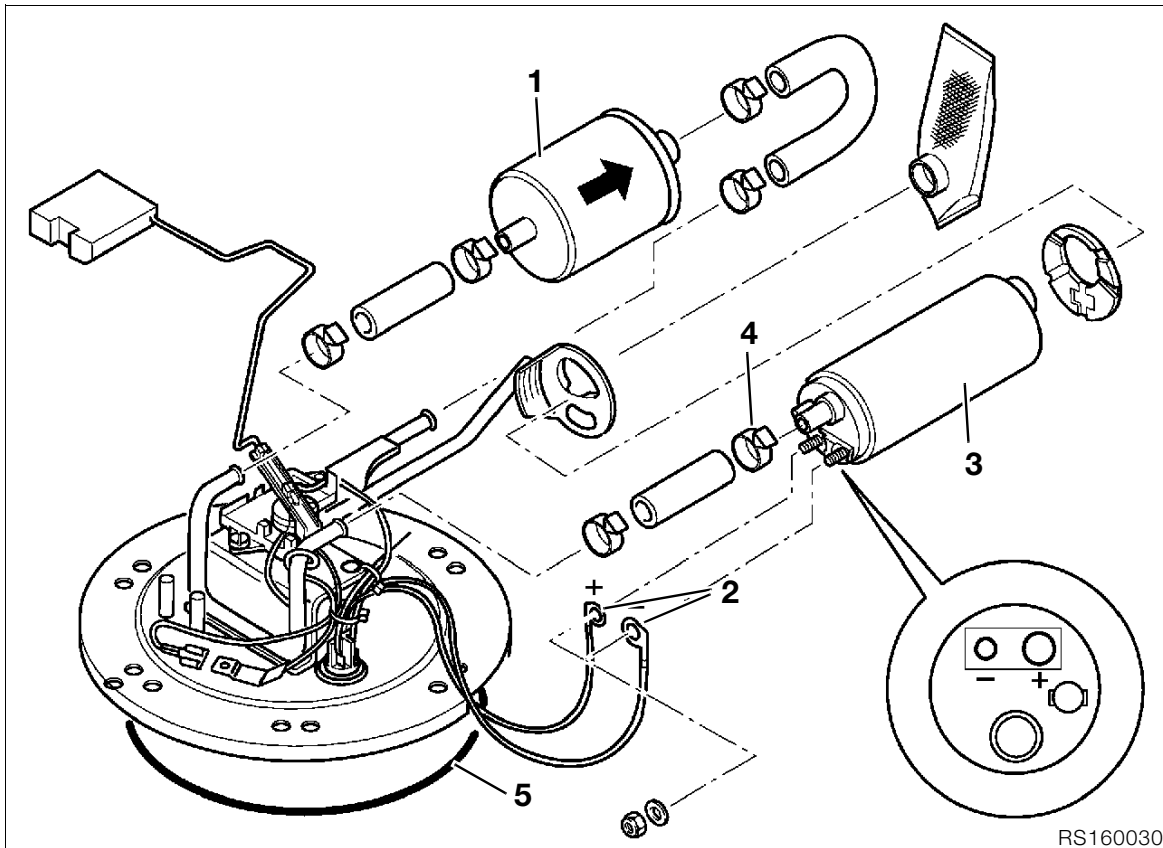

RS160030

### Removing and installing fuel filter



**Caution:**

Note direction of fuel flow through filter (1).

### Removing and installing fuel pump and fuel level sensor

- Unfasten electrical connections (2) at fuel pump (3).
- Unscrew hose clip (4).
- Remove fuel pump.
- Install in the reverse order of work.
- Tighten non-reusable hose clips with special pliers, **BMW No. 13 1 500**.



**Caution:**

Use only an O-ring (5) in good condition. After assembly, check fuel pump unit for leaks.



**Tightening torque:**

Fuel pump assembly to tank ..... 6 Nm

## Checking fuel pump pressure

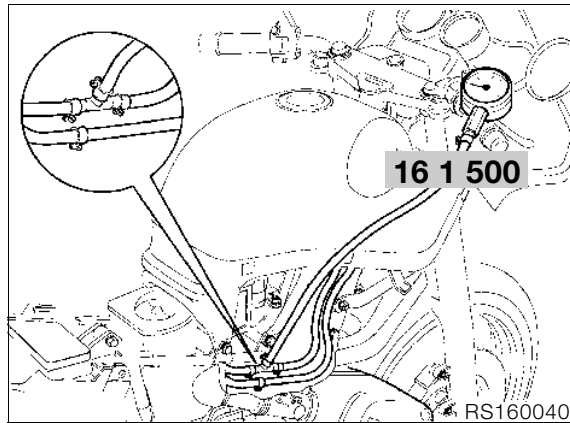

- Connect test pressure gauge, **BMW No. 16 1 500**, on the discharge side.
- Run engine at idle speed.

### Fuel pressure:

Nominal value..... 3 bar (43.51 psi)



#### Note:

If fuel pressure is low, check pump, fuel filter, pressure regulator and fuel line.

## Removing and installing fuel distributor and pressure regulator

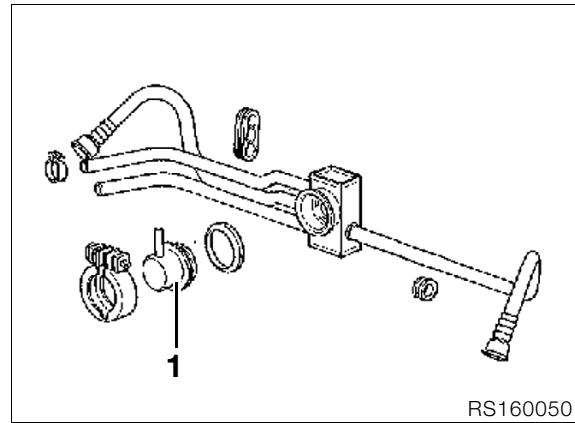

- Remove air cleaner box.  
→ See Group 23, Removing gearbox
- Pressure regulator (1).





# 18 Exhaust system

## Contents

Page

<b>Removing and installing exhaust system</b> .....	3
Removing and installing muffler (silencer) .....	3
Removing and installing front exhaust pipes .....	4

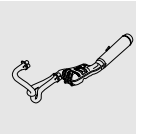

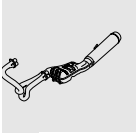

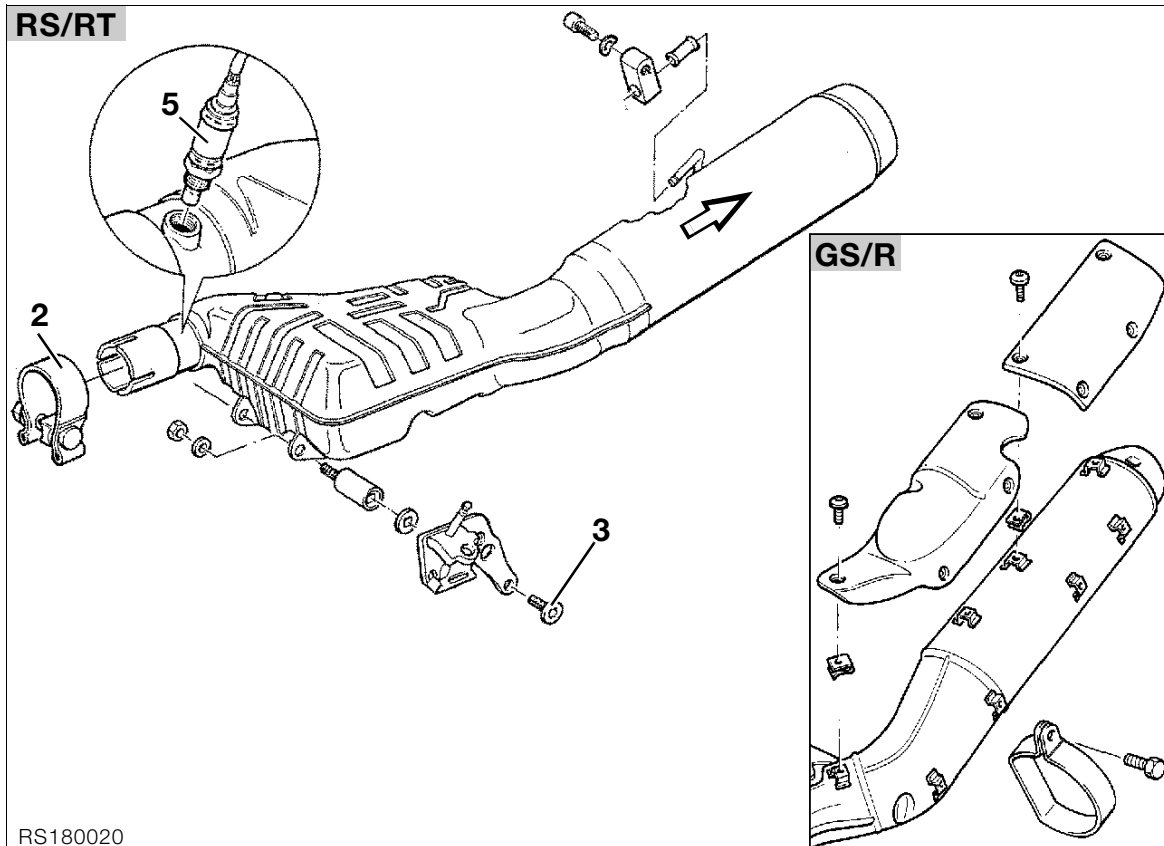

## Removing and installing exhaust system

### Removing and installing muffler (silencer)

- Loosen pipe clip (2).
- Unfasten retaining screws (3).
- **[RS/RT]** Take off the retainer at the rear muffler mount.
- **[GS/R]** Unscrew the rear pipe clip.
- Remove rear muffler.
- Install in the reverse order of work.

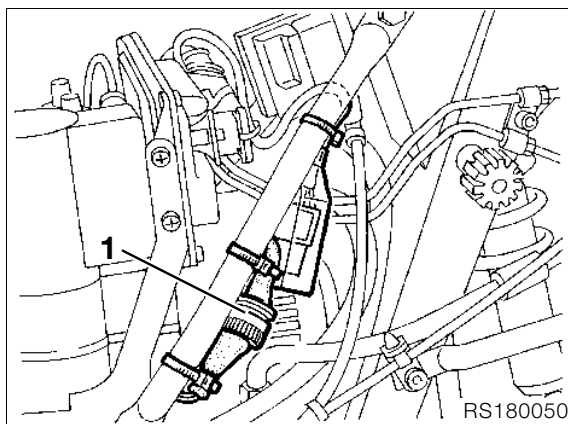
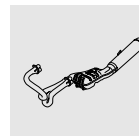

- **[KAT]** Detach fuel tank and pull it to rear.
- Separate plug connector (1) for oxygen sensor and detach cable.

**! Caution:**  
Do not pull the oxygen sensor cable.

**! Caution:**  
Note position of wiring for oxygen sensor.

**! Tightening torque:**  
**RS/RT]** Muffler to footrest ..... 35 Nm  
**[GS/R]** Muffler at rear frame ..... 24 Nm  
 Muffler to support plate for center stand ..... 20 Nm  
 Clip on muffler  
 (Grease clamping surface with Never Seeze) 50 Nm

- **[CAT]** Remove and install oxygen sensor (5).

**! Caution:**  
After trial run, read out Motronic fault memory.

**! Tightening torque:**  
 Oxygen sensor  
 (Grease with Never Seez) ..... 55 Nm

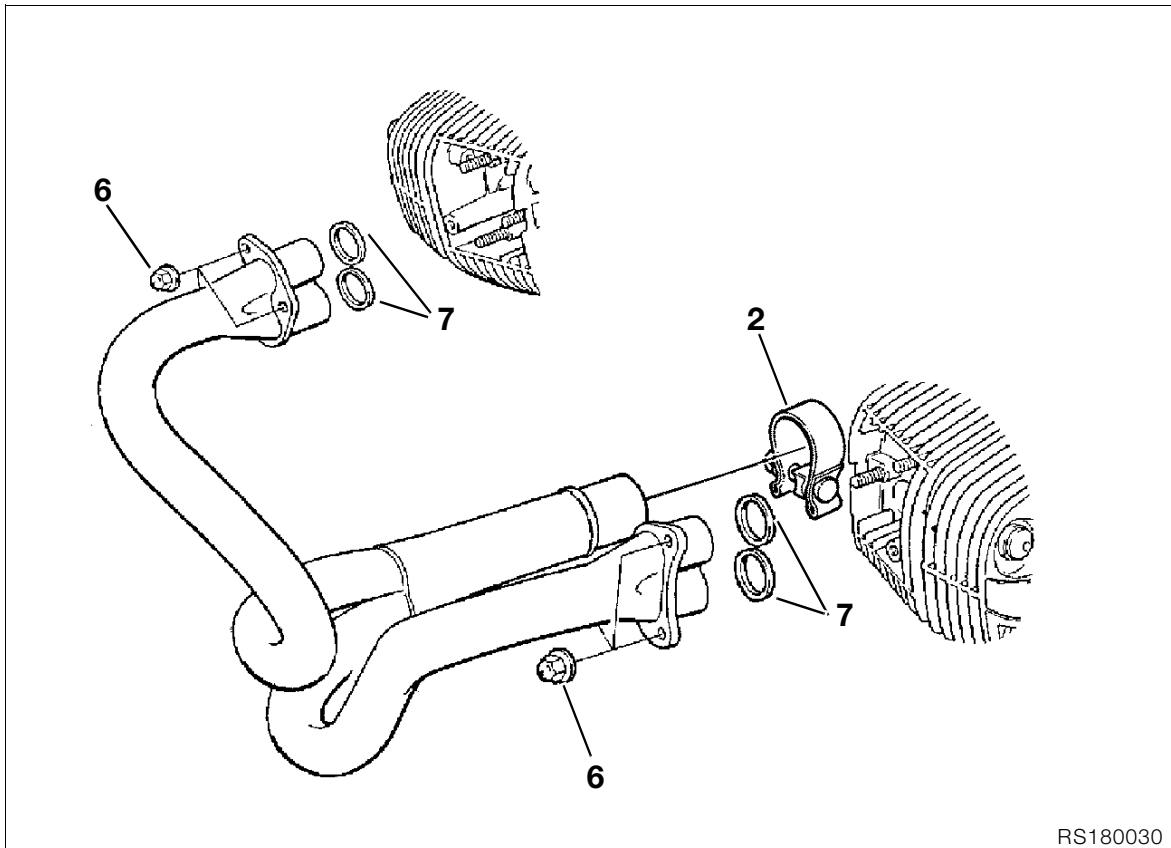

RS180030

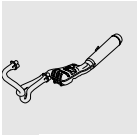

## Removing and installing front exhaust pipes

- Loosen pipe clip (2).
- Unscrew exhaust pipe mount (6).
- Take off front exhaust pipes.
- Install in the reverse order of work.



### Note:

When installing, use new seals (7).



### Tightening torque:

Front exhaust pipes  
 (with plate) at cylinder head ..... 22 Nm  
 Front exhaust pipes  
 (with outer pipe) at cylinder head ..... 18 Nm  
 Clip at muffler  
 (coat clamping surface with Never Seez) ..... 50 Nm

# 21 Clutch

<b>Contents</b>	Page
<b>Technical Data</b> .....	3
<b>Removing and installing clutch</b> .....	7
Removing clutch .....	9
Installing clutch .....	9
<b>Adjusting clutch operating clear-ance</b> .....	10





Technical Data		R 1100 RS
Type of clutch		Single dry plate with increased-leverage diaphragm spring
Operation		Mechanical, with release lever and thrust rod passing through hollow gearbox shaft
Clutch plate dia.	mm (in)	180 (7.0879)
Wear dimension	mm (in)	4,5 (0.177)
		(measured on rivets of clutch plate using tips of sliding caliper, pressed together by hand)
Manual effort required	Nm	65
Clutch operating clearance at handlebar lever	mm (in)	7 (0.276)
Distance for basic clutch adjustment (free thread length at adjusting screw on handlebar lever)	mm (in)	12 (0.472)

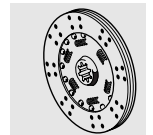

Technical Data			R 1100 RT
Type of clutch		Single dry plate with increased-leverage diaphragm spring	
Operation		Mechanical, with release lever and thrust rod passing through hollow gearbox shaft	
Clutch plate dia.	mm (in)		180 (7.0879)
Wear dimension	mm (in)		4,5 (0.177)
		(measured on rivets of clutch plate using tips of sliding caliper, pressed together by hand)	
Manual effort required	Nm		65
Clutch operating clearance at handlebar lever	mm (in)		7 (0.276)
Distance for basic clutch adjustment (free thread length at adjusting screw on handlebar lever)	mm (in)		12 (0.472)

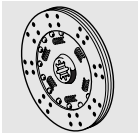



Technical Data		R 850 GS	R 1100 GS
Type of clutch		Single dry plate with increased-leverage diaphragm spring	
Operation		Mechanical, with release lever and thrust rod passing through hollow gearbox shaft	
Clutch plate dia.	mm (in)	180 (7.0879)	180 (7.0879)
Wear dimension	mm (in)	4,5 (0.177)	4,5 (0.177)
		(measured on rivets of clutch plate using tips of sliding caliper, pressed together by hand)	
Manual effort required	Nm	65	65
Clutch operating clearance at handlebar lever	mm (in)	7 (0.276)	7 (0.276)
Distance for basic clutch adjustment (free thread length at adjusting screw on handlebar lever)	mm (in)	12 (0.472)	12 (0.472)



Technical Data		R 850 R	R 1100 R
Type of clutch		Single dry plate with increased-leverage diaphragm spring	
Operation		Mechanical, with release lever and thrust rod passing through hollow gearbox shaft	
Clutch plate dia.	mm (in)	180 (7.0879)	180 (7.0879)
Wear dimension	mm (in)	4,5 (0.177)	4,5 (0.177)
		(measured on rivets of clutch plate using tips of sliding caliper, pressed together by hand)	
Manual effort required	Nm	65	65
Clutch operating clearance at handlebar lever	mm (in)	7 (0.276)	7 (0.276)
Distance for basic clutch adjustment (free thread length at adjusting screw on handlebar lever)	mm (in)	12 (0.472)	12 (0.472)



## Removing and installing clutch

- Remove dualseat.
- **[RT]** Remove mirror.
- **[RS/GS/RT]** Remove side sections of fairing.
- **[RS]** Detach inner cockpit panel at fuel tank.
- **[R]** Remove fuel tank cover.
- Unscrew fuel tank mount.
- Seal, loosen and pull off fuel feed and return line with hose clip, **BMW No. 13 0 010**.
- Remove vent pipes.
- Separate plug for fuel pump.
- Remove fuel tank.
- Remove battery.



### Caution:

Disconnect negative terminal from battery first, then positive terminal. Connect the positive battery terminal first, then the negative terminal.

- Motorcycles with throttle-cable divider, release Bowden-cable divider.
- Unscrew rear battery mount.
- Remove plug from air temperature sensor.
- Remove air cleaner cover.
- Detach air intake pipe and push it into the air cleaner housing.
- Remove front/rear air cleaner box.
- Remove muffler.
- Unfasten plug connector for neutral switch and side stand switch/detach leads.
- Disconnect plug for brake light switch and detach lead.
- **[ABS]/[GS/R/RT]** Detach the plug connection at the rear sensor line and the line itself.
- Remove brake fluid reservoir from holder.
- Remove rear brake pipe from holder.
- Unfasten screw connection on rear frame/only loosen mount at front of struts.
- Remove suspension strut.

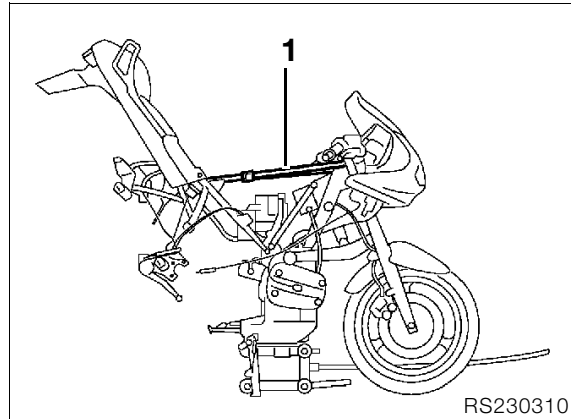

- Tilt rear frame upwards and secure with strap (1).
- **[ABS]** Detach rear brake caliper.
- **[ABS]** Take off right footrest plate.
- Unfasten/remove fuel pipe from injector.
- Remove cable connector/wiring harness from air cleaner box.
- Detach return line/oil trap from air cleaner box.
- Remove air cleaner box.
- Disconnect clutch cable from gearbox.
- **[RS/GS/R]** Take off starter motor cover/pull off wire to power socket.
- Detach leads at starter motor.
- Remove starter motor.

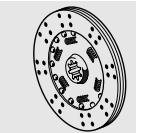

- Detach lead to oil pressure switch.
- Detach lead to side stand switch.
- Detach lead for injector.
- Detach lead for throttle angle sensor.

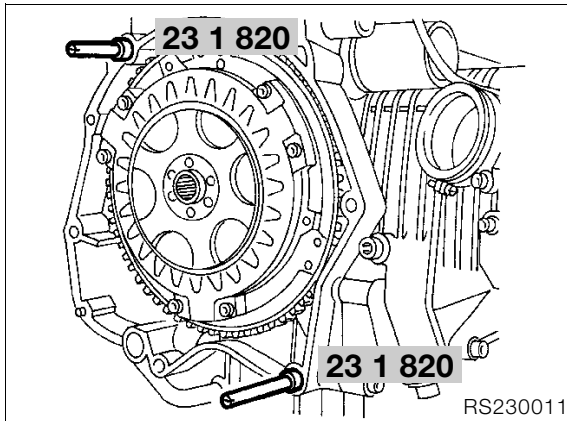

- Locate the gearbox when removing and installing with oiled guide pins, **BMW No. 23 1 820**.
- Remove rear wheel, rear wheel drive unit and swinging arm together with gearbox.



**Caution:**

Hold gearbox at installation height until entire clutch push rod is visible, or else this may be bent.

- Install in the reverse order of work.



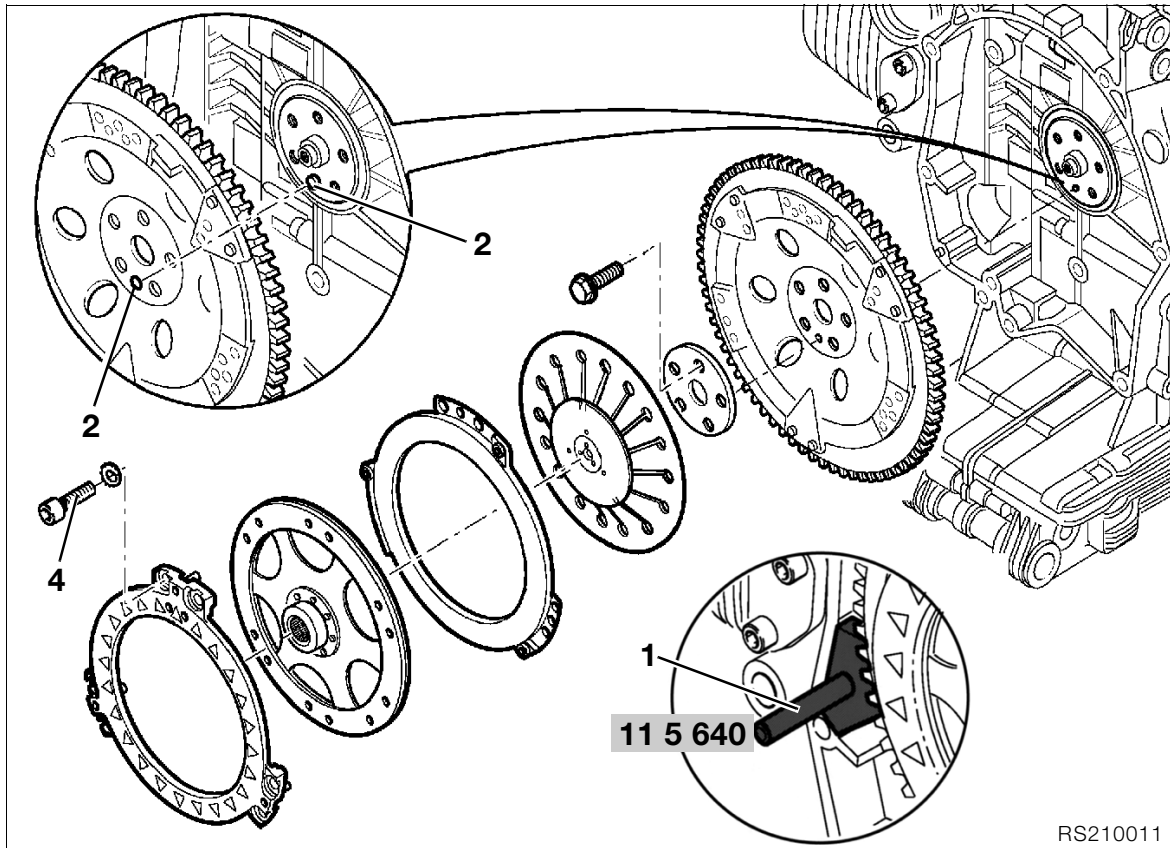

RS210011

## Removing clutch

- Lock the clutch housing with retaining device (1), **BMW No. 11 5 640**.
- Remove clutch.

## Installing clutch

### ! Caution:

Always use new bolts for housing and cover.

- Install clutch housing with mark (2) aligned with crankshaft mark (2).
- Lock the clutch housing with retaining device (1), **BMW No. 11 5 640**.
- Insert all screws by hand and tighten down.

### ! Tightening torque:

Clutch housing to crankshaft  
(oil screw threads lightly)  
Initial tightening ..... 40 Nm  
Wrench angle ..... 32°

- Install clutch.

### ! Caution:

Offset the color marks on the clutch housing, driven plate and housing cover through 120° in each case.

- Secure clutch with retaining screws (4).
- Center the clutch plate with centering pin, **BMW No. 21 3 680**.
- Tighten retaining screws alternately in a cross-wise pattern.

### Lubrication points:

Splines on clutch plate and input shaft  
Diaphragm spring contact surface at clutch housing  
Diaphragm spring contact surface at driven plate  
..... Optimoly MP3 paste

### ! Tightening torque:

Housing cover to flywheel ..... 18 Nm



## Adjusting clutch operating clearance

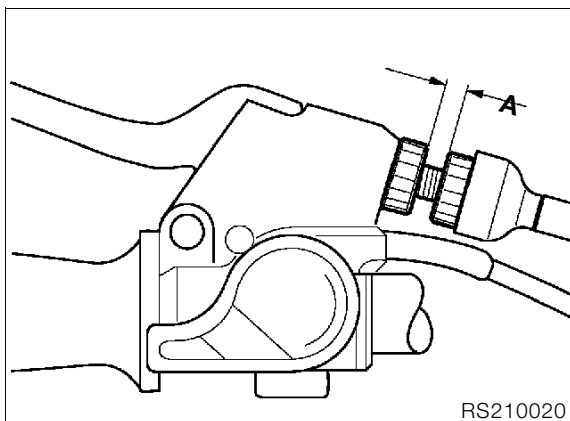

- Turn adjusting screw to obtain distance A.

**Distance A:** ..... 12 mm (0.472 in)

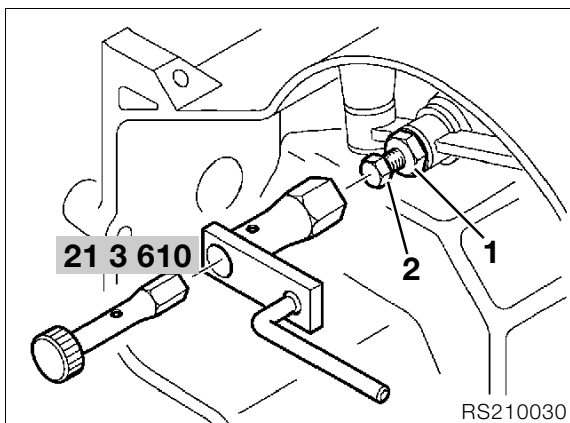

- **[GS]** If necessary, detach the hydraulic spring adjusted with a 6 mm (0.24 in) Allen key, **BMW No. 31 5 600**.
- **[RT]** If necessary, detach the power socket holder.
- Using socket wrench, **BMW No. 21 3 610**, loosen locknut (1) for adjusting screw (2) at clutch release lever.

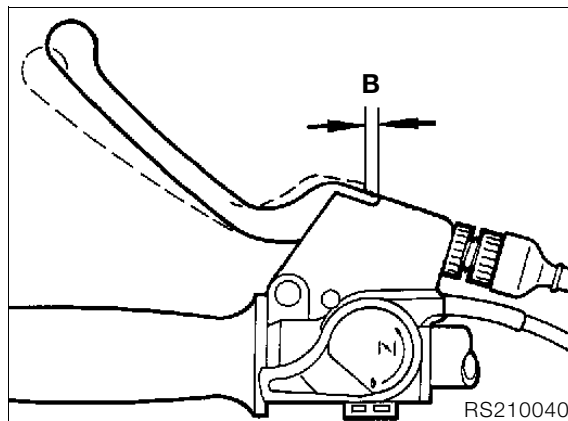

- Set to distance B at the handlebar lever by turning adjusting screw (2) on the clutch release lever.

**Distance B:** ..... 7 mm (0.276 in)

**Tightening torque:**  
Locknut on adjusting screw ..... 22 Nm

# 23 Gearbox

<b>Contents</b>	<b>Page</b>
<b>Technical Data</b> .....	3
<b>Gearbox - sectioned drawing</b> .....	7
<b>Removing and installing clutch bearing/thrust rod/release lever</b> .....	9
<b>Removing and installing gear shift pedal</b> .....	10
<b>Removing gearbox</b> .....	10
<b>Dismantling/reassembling</b> .....	12
Replacing shaft seal on neutral switch .....	12
Removing gearbox cover .....	13
Removing selector drum .....	14
Removing gearbox shafts .....	15
Removing and installing input shaft sealing ring at housing end .....	15
Removing/dismantling/reassembling selector shaft .....	16
Removing and installing detent lever .....	17
Removing and installing shift pawls .....	17
Removing and installing torsion spring .....	17
Removing and installing selector shaft seal .....	17
Removing deep-groove ball bearing from selector drum .....	18
Shimming selector drum .....	18
Removing taper roller bearing race from input shaft and roller bearing from idler shaft .....	18
Installing deep-groove ball bearing on selector drum .....	19
Installing taper roller bearing race on input shaft and roller bearing for idler shaft .....	19
Removing and installing deep-groove ball bearing and race/roller bearing for idler shaft .....	20
Dismantling/reassembling input shaft .....	21
Disassembling/assembling input shaft (Clean Bearing) .....	23

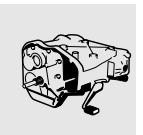

# Contents

Page

Dismantling/reassembling output shaft .....	25
Removing deep-groove ball bearing .....	25
Removing spur gears .....	26
Installing spur gears .....	27
Installing gearbox shafts .....	29
Removing and installing output shaft seal .....	30
Installing selector shaft .....	31
Installing selector forks .....	32
Installing selector drum .....	32
Shimming gearbox shafts .....	33
Measuring shaft bearing play .....	33
Measuring gearbox cover .....	34
<b>Shimming the gearbox shafts (without Clean Bearing) .....</b>	<b>35</b>
Example .....	35
<b>Shimming the gearbox shafts (with Clean Bearing) .....</b>	<b>35</b>
Example .....	35
Removing and installing taper roller bearing race .....	36
Checking friction coefficient of input shaft taper roller bearing .....	36
Installing gearbox cover .....	37
Removing and installing input shaft seal at housing cover end .....	38
Completing assembly of gearbox .....	39
<b>Installing gearbox .....</b>	<b>40</b>

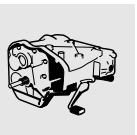



Technical Data	R 1100 RS	
Type of gearbox	5-speed gearbox with claw-action shift and integral reaction damper for all gears	
Type of selector mechanism	Pedal-operated lever and selector drum with overshoot detent	
Gear ratios	up to 1993 model year	
1st gear	4,030	
2nd gear	2,576	
3rd gear	1,886	
4th gear	1,538	
5th gear	1,318	
Gear ratios	from 1994 (gearbox No. ....M94)	
1st gear	4,163	
2nd gear	2,914	
3rd gear	2,133	
4th gear	1,740	
5th gear	1,450	
Oil grade (all the year round)	Brand-name SAE 90 hypoid gear oil, API Class GL 5	
Filling capacity	Initial filling	
	l (Imp. pints)	1.0 (1.76) (to lower edge of filler screw)
		When oil is changed
	l (Imp. pints)	approx. 0.8 (1.408) (to lower edge of filler screw)
End float on idler shaft	mm (in)	0,05...0,15 (0.00196...0.0059)
End float on output shaft	mm (in)	0,05...0,15 (0.00196...0.0059)
End float, input shaft (Clean Bearing)	mm (in)	0,05...0,15 (0.00196...0.0059)
Preload on input shaft		0.2 mm (0.00787) = 0.5...1.0 Nm frictio
End float at selector drum/deep-groove ball bearing	mm (in)	< 0,1 (0.0039)
End float at deep-groove ball bearing/housing	mm (in)	< 0,1 (0.0039)
<b>Input-shaft conversion to Clean Bearing</b>	As of gearbox No. 10483 DAF 10776 DAH 12958 DAK 12650 DAL 12405 DAG 7864 DAJ 131 DCF 101 DCH	
<b>Full conversion to Clean Bearing BMW No.: 2.325.222...227</b>	As of gearbox No. 101 DAQ 101 DAR 101 DAS 101 DAT 101 DAU 101 DAV 101 DCQ 101 DCR	

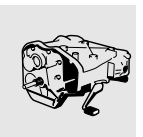

Technical Data		R 1100 RT
Type of gearbox	5-speed gearbox with claw-action shift and integral reaction damper for all gears	
Type of selector mechanism	Pedal-operated lever and selector drum with overshoot detent	
Gear ratios	from 1994 (gearbox No. ....M94)	
1st gear	4,163	
2nd gear	2,914	
3rd gear	2,133	
4th gear	1,740	
5th gear	1,450	
Oil grade (all the year round)	Brand-name SAE 90 hypoid gear oil, API Class GL 5	
Filling capacity	Initial filling	
	I (Imp. pints)	1.0 (1.76) (to lower edge of filler screw)
		When oil is changed
	I (Imp. pints)	approx. 0.8 (1.408) (to lower edge of filler screw)
End float on idler shaft	mm (in)	0,05...0,15 (0.00196...0.0059)
End float on output shaft	mm (in)	0,05...0,15 (0.00196...0.0059)
End float, input shaft (Clean Bearing)	mm (in)	0,05...0,15 (0.00196...0.0059)
Preload on input shaft		0.2 mm (0.00787) = 0.5...1.0 Nm frictio
End float at selector drum/deep-groove ball bearing	mm (in)	< 0,1 (0.0039)
End float at deep-groove ball bearing/housing	mm (in)	< 0,1 (0.0039)
<b>Input-shaft conversion to Clean Bearing</b>		As of gearbox No. 10483 DAF 10776 DAH 12958 DAK 12650 DAL 12405 DAG 7864 DAJ 131 DCF 101 DCH
<b>Full conversion to Clean Bearing BMW No.: 2.325.222...227</b>		As of gearbox No. 101 DAQ 101 DAR 101 DAS 101 DAT 101 DAU 101 DAV 101 DCQ 101 DCR



Technical Data	R 850 GS	R 1100 GS
Type of gearbox	5-speed gearbox with claw-action shift and integral reaction damper for all gears	
Type of selector mechanism	Pedal-operated lever and selector drum with overshoot detent	
Gear ratios		
1st gear	4,163	4,163
2nd gear	2,914	2,914
3rd gear	2,133	2,133
4th gear	1,740	1,740
5th gear	1,450	1,450
Oil grade (all the year round)	Brand-name SAE 90 hypoid gear oil, API Class GL 5	Brand-name SAE 90 hypoid gear oil, API Class GL 5
Filling capacity	Initial filling	Initial filling
I (Imp. pints)	1.0 (1.76) (to lower edge of filler screw)	1.0 (1.76) (to lower edge of filler screw)
I (Imp. pints)	When oil is changed approx. 0.8 (1.408) (to lower edge of filler screw)	When oil is changed approx. 0.8 (1.408) (to lower edge of filler screw)
End float on idler shaft	mm (in) 0,05...0,15 (0.00196...0.0059)	0,05...0,15 (0.00196...0.0059)
End float on output shaft	mm (in) 0,05...0,15 (0.00196...0.0059)	0,05...0,15 (0.00196...0.0059)
End float, input shaft (Clean Bearing)	mm (in) 0,05...0,15 (0.00196...0.0059)	0,05...0,15 (0.00196...0.0059)
Preload on input shaft	0.2 mm (0.00787) = 0.5...1.0 Nm frictio	0.2 mm (0.00787) = 0.5...1.0 Nm frictio
End float at selector drum/deep-groove ball bearing	mm (in) < 0,1 (0.0039)	< 0,1 (0.0039)
End float at deep-groove ball bearing/housing	mm (in) < 0,1 (0.0039)	< 0,1 (0.0039)
<b>Input-shaft conversion to Clean Bearing</b>		As of gearbox No. 10483 DAF 10776 DAH 12958 DAK 12650 DAL 12405 DAG 7864 DAJ 131 DCF 101 DCH
<b>Full conversion to Clean Bearing BMW No.: 2.325.222...227</b>		As of gearbox No. 101 DAQ 101 DAR 101 DAS 101 DAT 101 DAU 101 DAV 101 DCQ 101 DCR

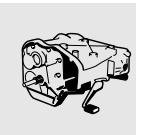

Technical Data	R 850 R	R 1100 R
Type of gearbox	5-speed gearbox with claw-action shift and integral reaction damper for all gears	
Type of selector mechanism	Pedal-operated lever and selector drum with overshoot detent	
Gear ratios		
1st gear	4,163	4,163
2nd gear	2,914	2,914
3rd gear	2,133	2,133
4th gear	1,740	1,740
5th gear	1,450	1,450
Oil grade (all the year round)	Brand-name SAE 90 hypoid gear oil, API Class GL 5	Brand-name SAE 90 hypoid gear oil, API Class GL 5
Filling capacity	Initial filling	Initial filling
I (Imp. pints)	1.0 (1.76) (to lower edge of filler screw)	1.0 (1.76) (to lower edge of filler screw)
I (Imp. pints)	When oil is changed approx. 0.8 (1.408) (to lower edge of filler screw)	When oil is changed approx. 0.8 (1.408) (to lower edge of filler screw)
End float on idler shaft	mm (in) 0,05...0,15 (0.00196...0.0059)	0,05...0,15 (0.00196...0.0059)
End float on output shaft	mm (in) 0,05...0,15 (0.00196...0.0059)	0,05...0,15 (0.00196...0.0059)
End float, input shaft (Clean Bearing)	mm (in) 0,05...0,15 (0.00196...0.0059)	0,05...0,15 (0.00196...0.0059)
Preload on input shaft	0.2 mm (0.00787) = 0.5...1.0 Nm frictio	0.2 mm (0.00787) = 0.5...1.0 Nm frictio
End float at selector drum/deep-groove ball bearing	mm (in) < 0,1 (0.0039)	< 0,1 (0.0039)
End float at deep-groove ball bearing/housing	mm (in) < 0,1 (0.0039)	< 0,1 (0.0039)
<b>Input-shaft conversion to Clean Bearing</b>	As of gearbox No. 10483 DAF 10776 DAH 12958 DAK 12650 DAL 12405 DAG 7864 DAJ 131 DCF 101 DCH	As of gearbox No. 10483 DAF 10776 DAH 12958 DAK 12650 DAL 12405 DAG 7864 DAJ 131 DCF 101 DCH
<b>Full conversion to Clean Bearing BMW No.: 2.325.222...227</b>	As of gearbox No. 101 DAQ 101 DAR 101 DAS 101 DAT 101 DAU 101 DAV 101 DCQ 101 DCR	As of gearbox No. 101 DAQ 101 DAR 101 DAS 101 DAT 101 DAU 101 DAV 101 DCQ 101 DCR

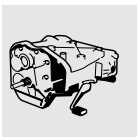

# Gearbox - sectioned drawing

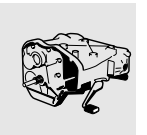
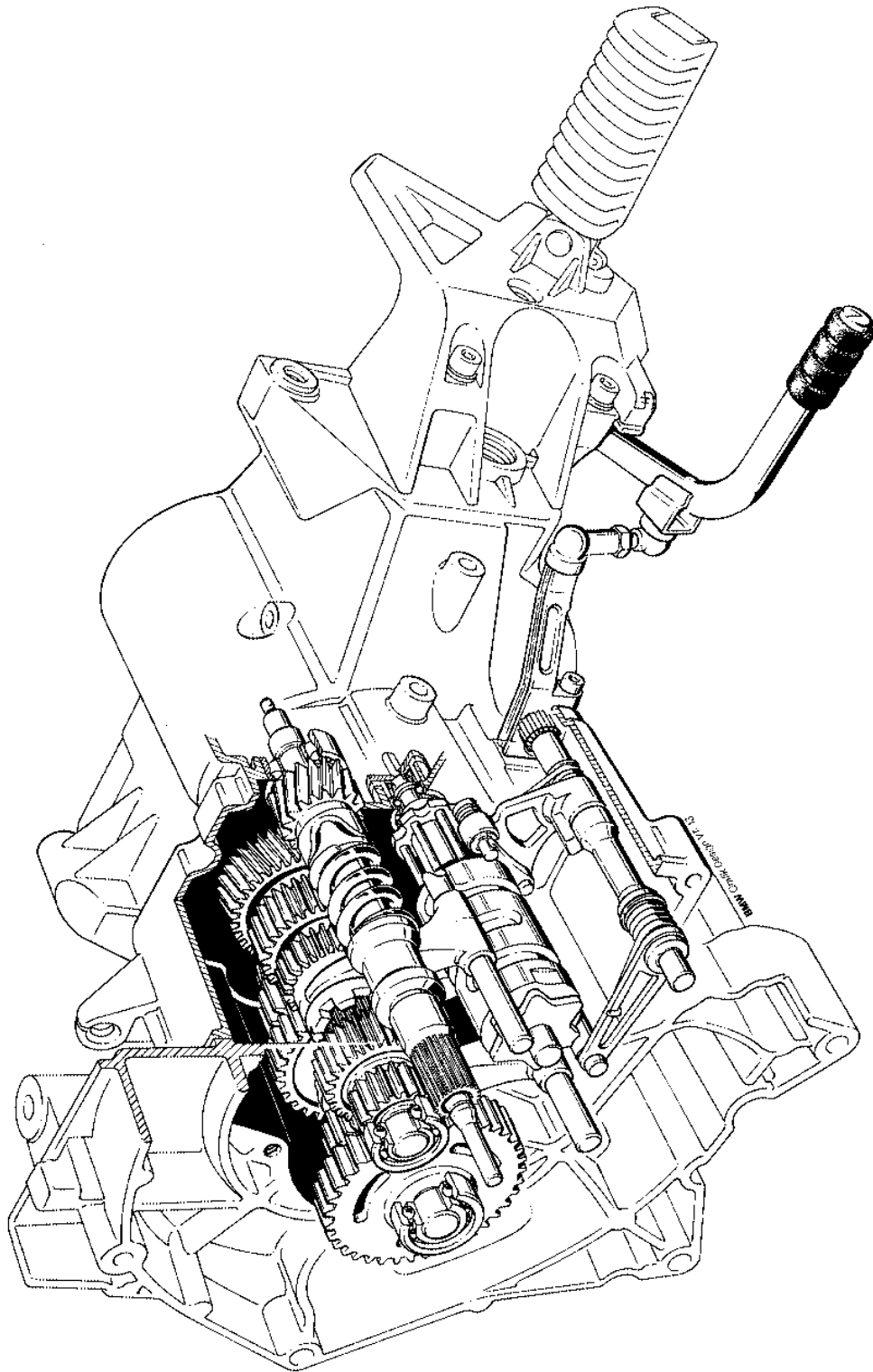

RS239010

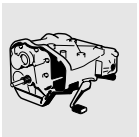

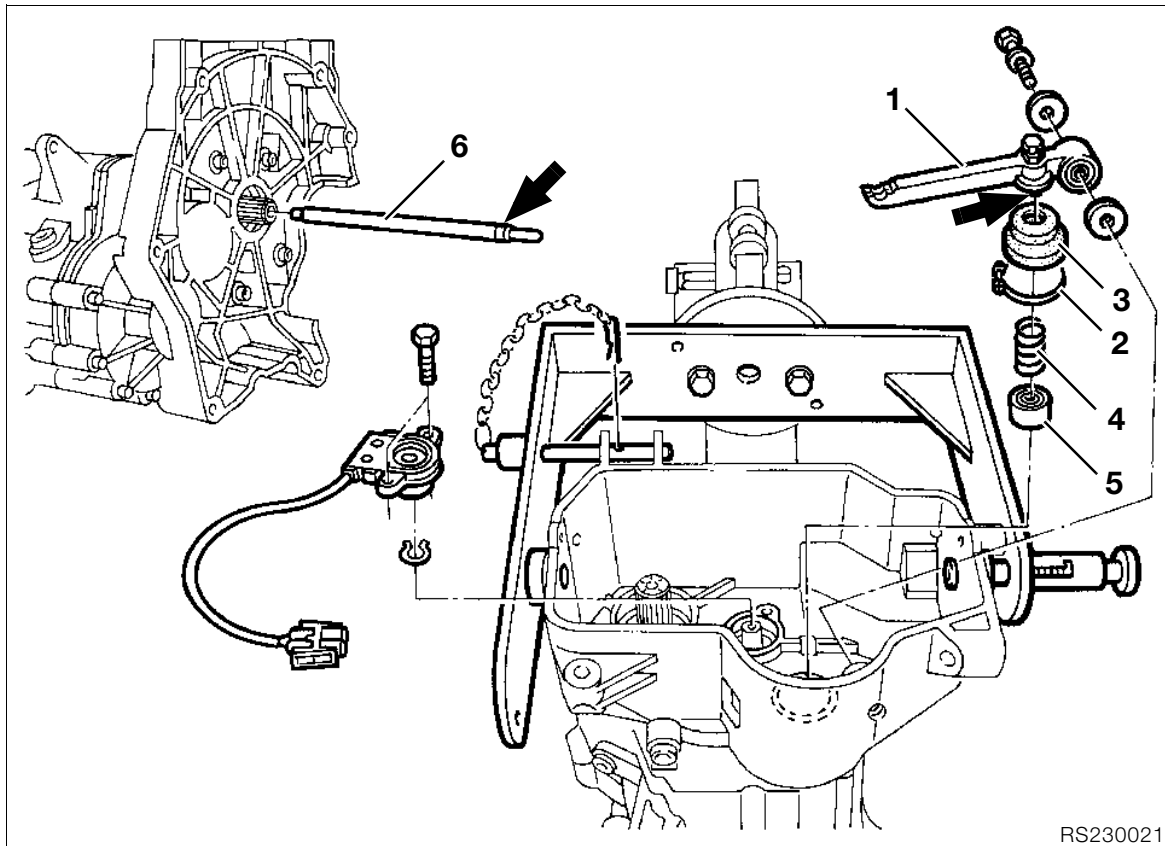

### Removing and installing clutch bear-ing/thrust rod/release lever

- Unfasten and remove brake caliper.
- **[ABS]/[GS/R/RT]** Detach plug connector for rear sensor and wire.
- Remove rear wheel.
- Remove rear wheel drive assembly/heat pivot pin to max. 120 °C /remove.
- **[RT]** Remove the footrest plates.
- Remove swinging arm and drive shaft/heat pivot pin to max. 120 °C /remove.
- Disconnect clutch cable from release lever.
- Remove release lever (1).
- Unscrew clip (2).
- Remove sleeve and spring (3/4).
- Remove clutch piston (5).
- Withdraw clutch thrust rod (6).

#### Lubricating points (arrow):

.....Optimoly MP3 compound

- Install in the reverse order of work.



#### Note:

Check/adjust clutch operating clearance.



#### Note:

Check clutch release bearing at piston (5); make sure that it moves freely, is not worn and is adequately greased.

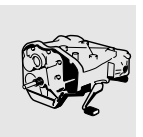

## Removing and installing gear shift pedal

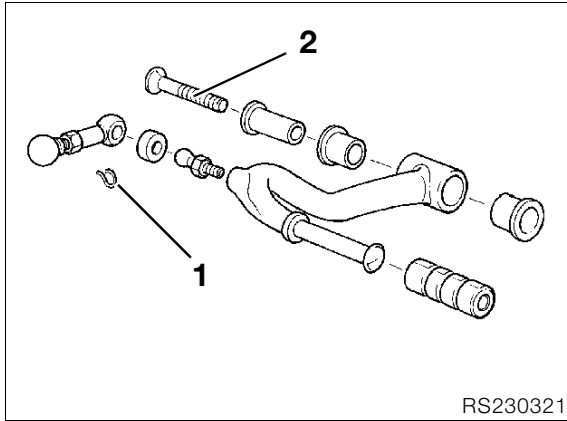

- Remove retaining bracket (1) and unfasten ball head.
- Remove retaining screw (2) on gear shift pedal.



### ! Tightening torque:

Gear shift pedal to footrest plate

<b>[RS/GS/R]</b> .....	35 Nm
<b>[RT]</b> .....	18 Nm

## Removing gearbox

- Remove dualseat.
- **[RS/GS/RT]** Remove side sections of fairing.
- **[RS]** Detach inner cockpit panel at fuel tank.
- **[R]** Remove fuel tank cover.
- Unscrew fuel tank mount.
- Seal, loosen and pull off fuel feed and return line using hose clip, **BMW No. 13 0 010**.
- Remove vent pipes.
- Separate plug for fuel pump.
- Remove fuel tank.
- Remove battery.



### Caution:

Disconnect the negative battery terminal first, then the positive terminal. Connect the positive battery terminal first, then the negative terminal.

- Motorcycles with throttle-cable divider, release Bowden-cable divider.
- Unscrew rear battery mount.
- Remove plug from air temperature sensor.
- Remove air cleaner cover.
- Detach air intake pipe and push it into the air cleaner box.
- Unfasten air cleaner box at front and rear.
- Remove muffler.
- Separate connector between neutral switch and prop stand switch and detach lead.
- Remove connector from brake light switch and lead.
- **[ABS]/[GS/R/RT]** Disconnect the plug for the rear sensor line and the wire itself.
- **[ABS]** brake master cylinder - detach at footrest plate.

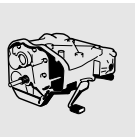



- Remove brake fluid reservoir from holder.
- Remove rear brake pipe from holder.
- Detach retaining clip from ball head/shift linkage and remove ball head.
- Take off the footrest plates.
- Unfasten rear frame screw connections but only loosen front strut mounts.
- Remove suspension strut.

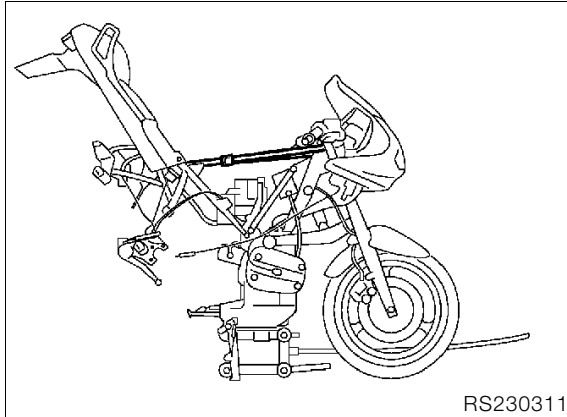

- Tilt rear frame upwards and secure with strap.

- Remove rear brake caliper.
- Unfasten strut at gearbox housing.
- Heat rear wheel drive pivot pin to max. 120 °C/loosen.
- Remove rear wheel.
- Remove rear wheel drive unit.
- Remove swinging arm/heat pivot pin to max. 120 °C and remove.
- Press off drive shaft.
- Unfasten fuel line from injector and remove.
- Remove cable connector/wiring harness from air cleaner box.
- Detach return line/oil trap from air cleaner box.
- Remove air cleaner box.
- Disconnect clutch cable from gearbox.
- **[RS/GS/R]** Detach starter motor cover and pull off wire to power socket.
- Detach cable from starter motor.
- Detach oil pressure sensor cable.
- Detach side stand switch cable.
- Detach injector cable
- Detach throttle angle sensor cable.

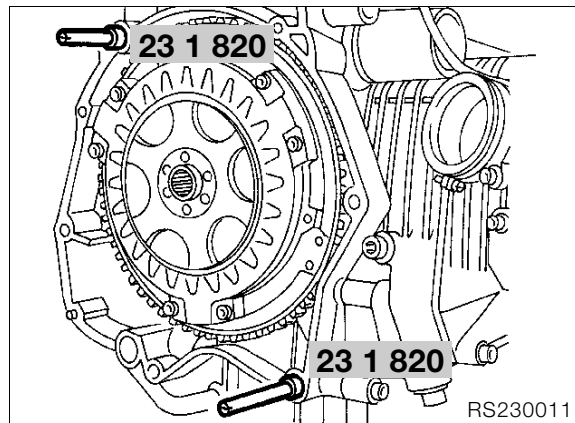

- When removing gearbox, pull it out on guide pins, **BMW No. 23 1 820**.

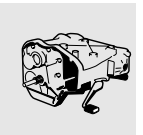

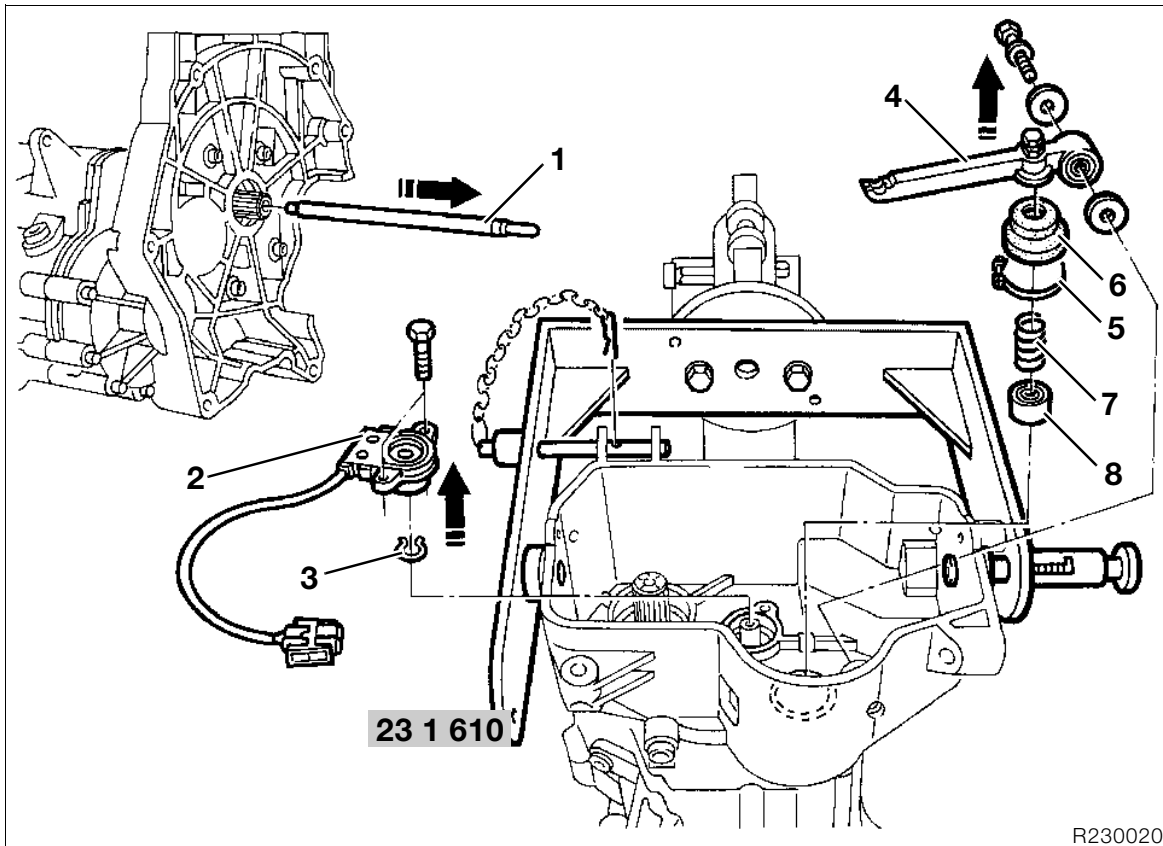

### Dismantling/reassembling

- Drain gearbox oil.
- Remove clutch thrust rod (1).
- Secure gearbox with assembly fixture, **BMW No. 23 1 610**, to assembly stand.
- Remove neutral switch (2).
- Remove retaining ring (3) from selector drum.
- Unfasten retaining screw on clutch lever (4).
- Unfasten hose clip (5).
- Remove sleeve (6), coil spring (7) and clutch piston (8).

### Replacing shaft seal on neutral switch

- Remove shaft seal using a suitable tool.
- Using light fingertip pressure, insert the shaft seal fully.

#### Direction of installation:

..... spring facing oil chamber

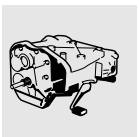

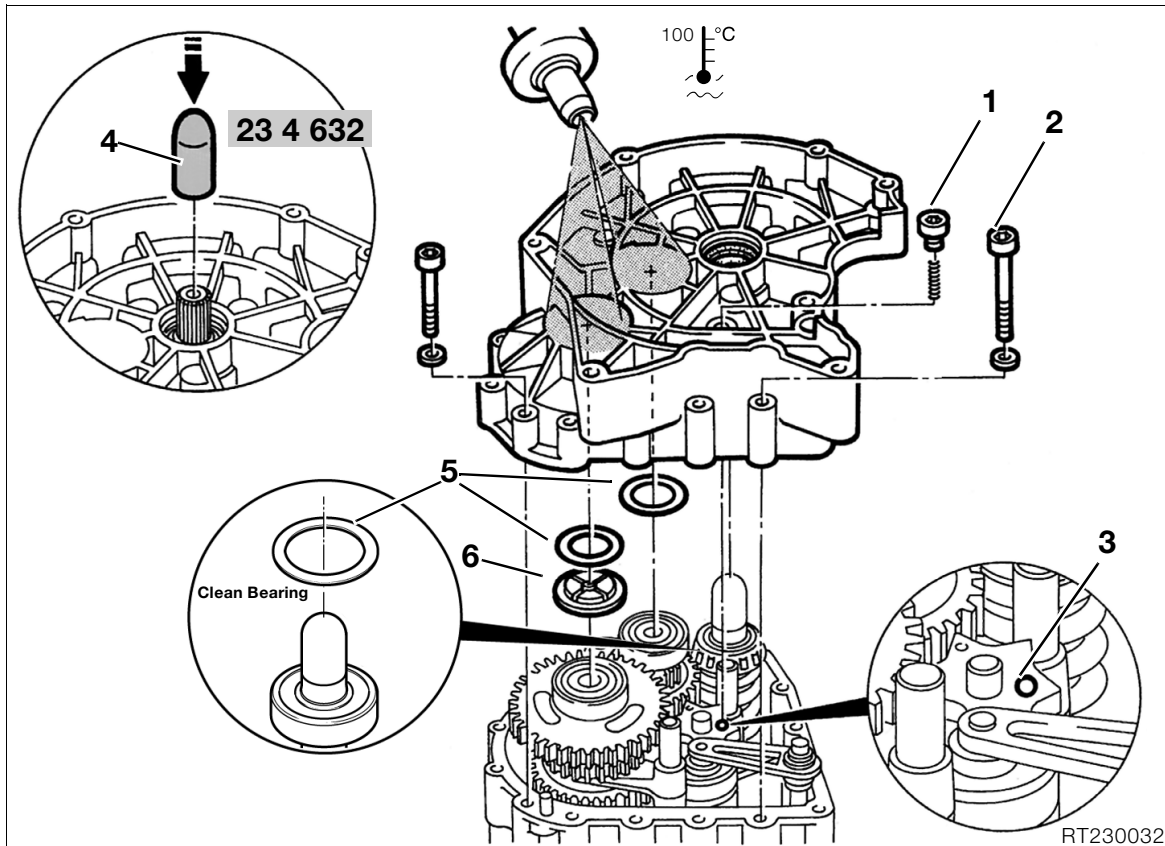

## Removing gearbox cover

- Unfasten screw (1) for idle speed detent and remove coil spring (2).
- Remove retaining screws from gearbox cover.
- Heat gearbox cover to 100 °C at the bearing seats.
- Place sliding sleeve, **BMW No. 23 4 632**, on the input shaft.
- Press off gearbox cover evenly.
- Remove ball (3) from neutral stop.
- Remove spacers (5)/oil baffle plate (6).



### Caution:

Do not accidentally confuse spacers!

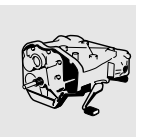

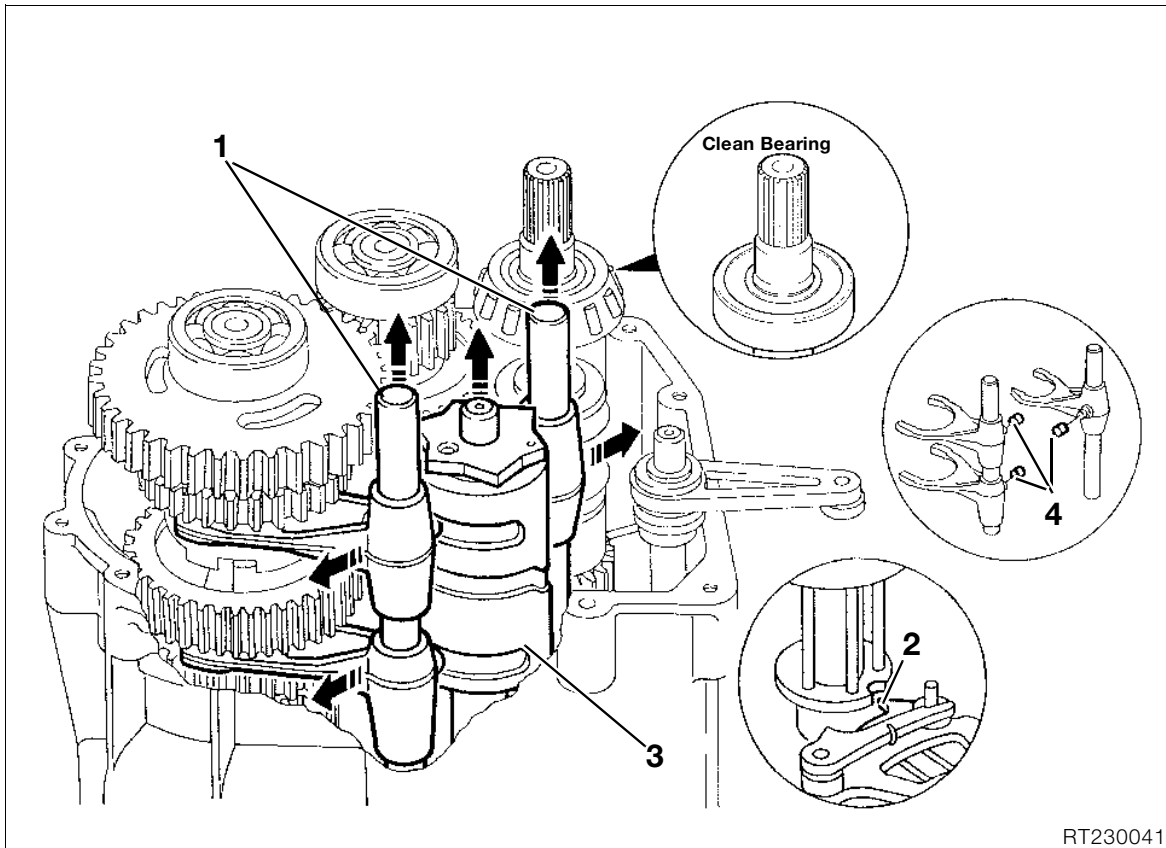

RT230041

## Removing selector drum

- Withdraw selector fork shafts (1) from gearbox housing.
- Turn selector forks outwards.
- Position pawl (2) opposite recess in selector drum.



### Note:

Avoid damage to rollers (4) on guide pins of selector forks.

- Withdraw selector drum (3), turning it slightly at the same time.
- Remove selector forks.



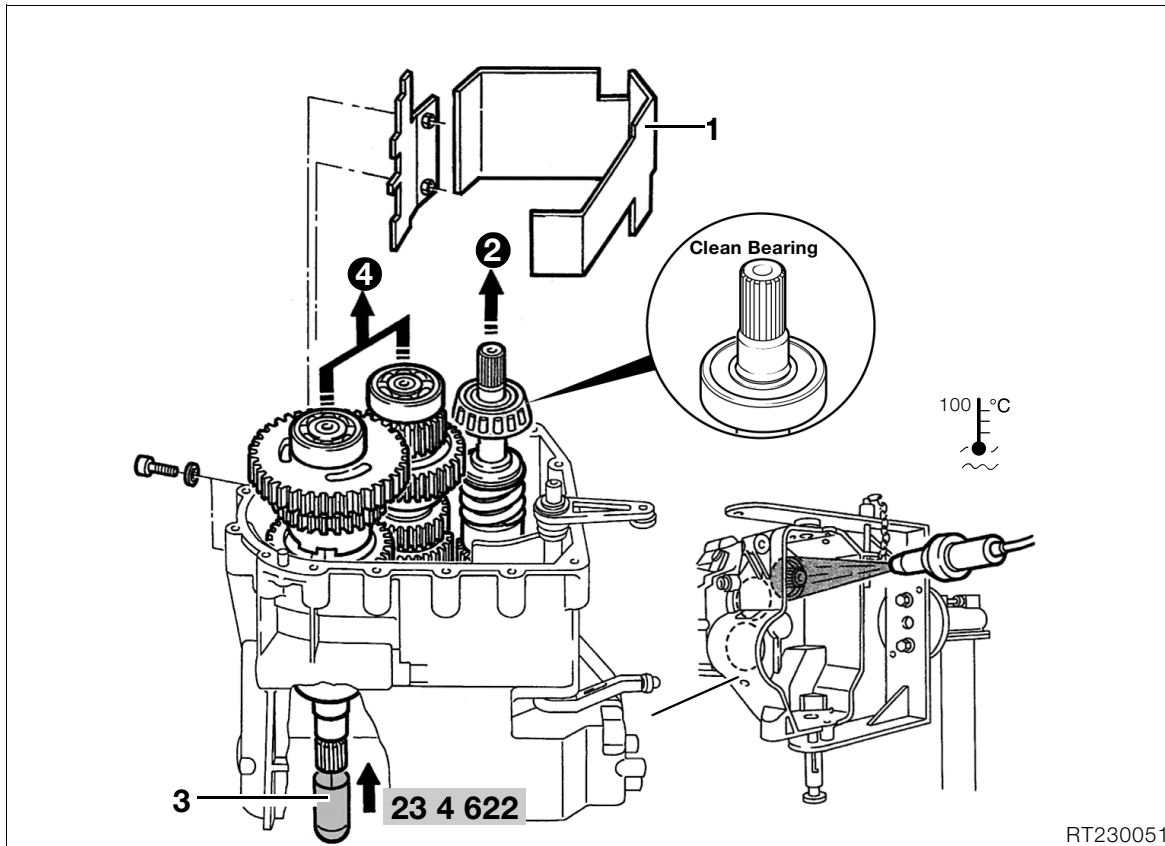

RT230051

### Removing gearbox shafts

- Remove oil baffle plates (1).
- **[1993 model year]** Pull input shaft (2) out of gearbox housing.
- Heat output shaft bearing point to 100 °C
- **[Clean Bearing input shaft]** Heat bearing journals of input shaft and output shaft to 100 °C
- **[Full Clean Bearing kit]** Heat all 3 bearing journals to 100 °C.
- Place sliding sleeve (3), **BMW No. 23 4 622**, on output shaft..
- **[1993 model year]** Pull the idler and output shaft (4) out of the gearbox housing together.
- **[from 1994 model year on]** Pull the input, idler and output shaft out of the gearbox housing together.

### Removing and installing input shaft sealing ring at housing end

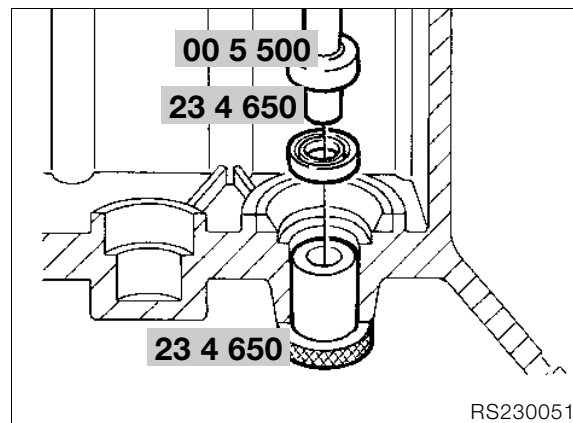

RS230051

- Force shaft seal inwards using drift.
- Drive in the sealing ring with a drift and guide sleeve, **BMW No. 23 4 650**, and with handle, **BMW No. 00 5 500**.

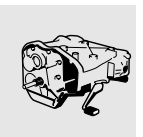

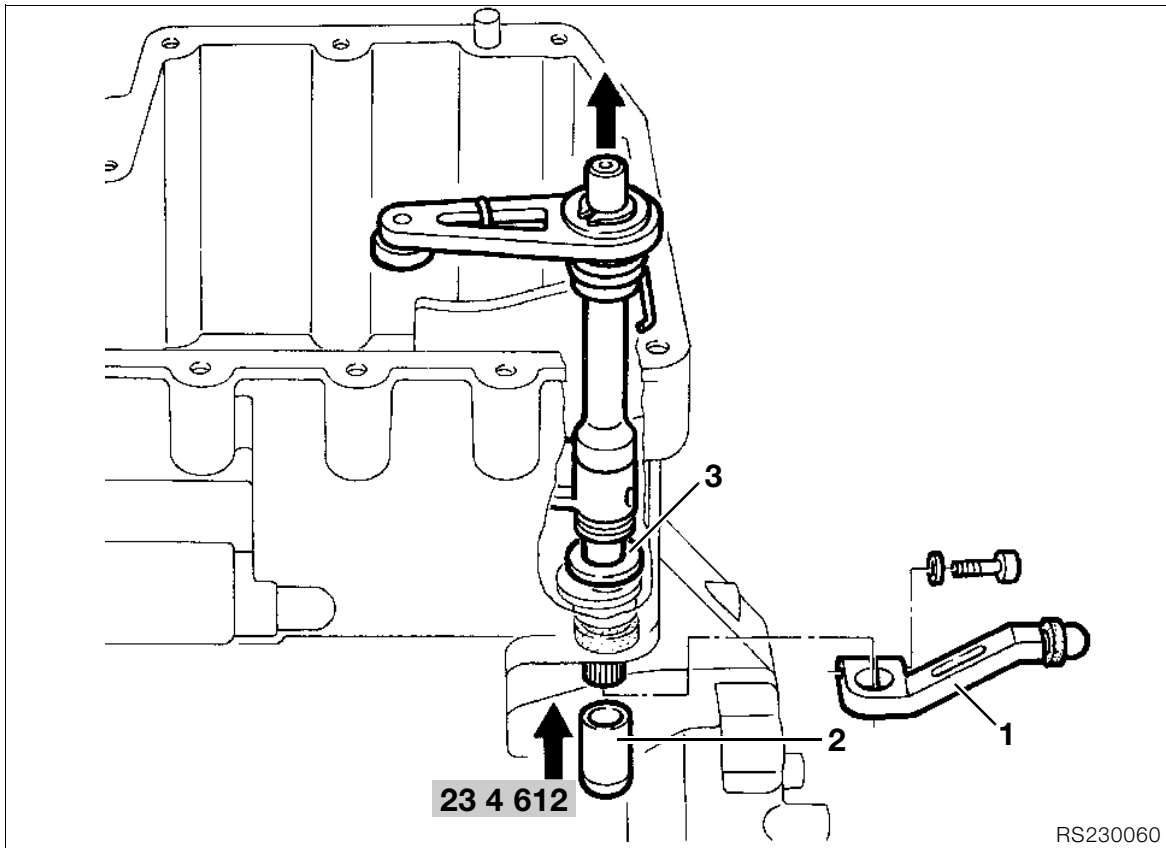

### Removing/dismantling/reassembling selector shaft

- Remove selector shaft (1).
- Attach sliding sleeve (2), **BMW No. 23 4 612**, and pull out selector shaft with washer (3).

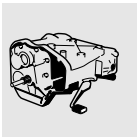

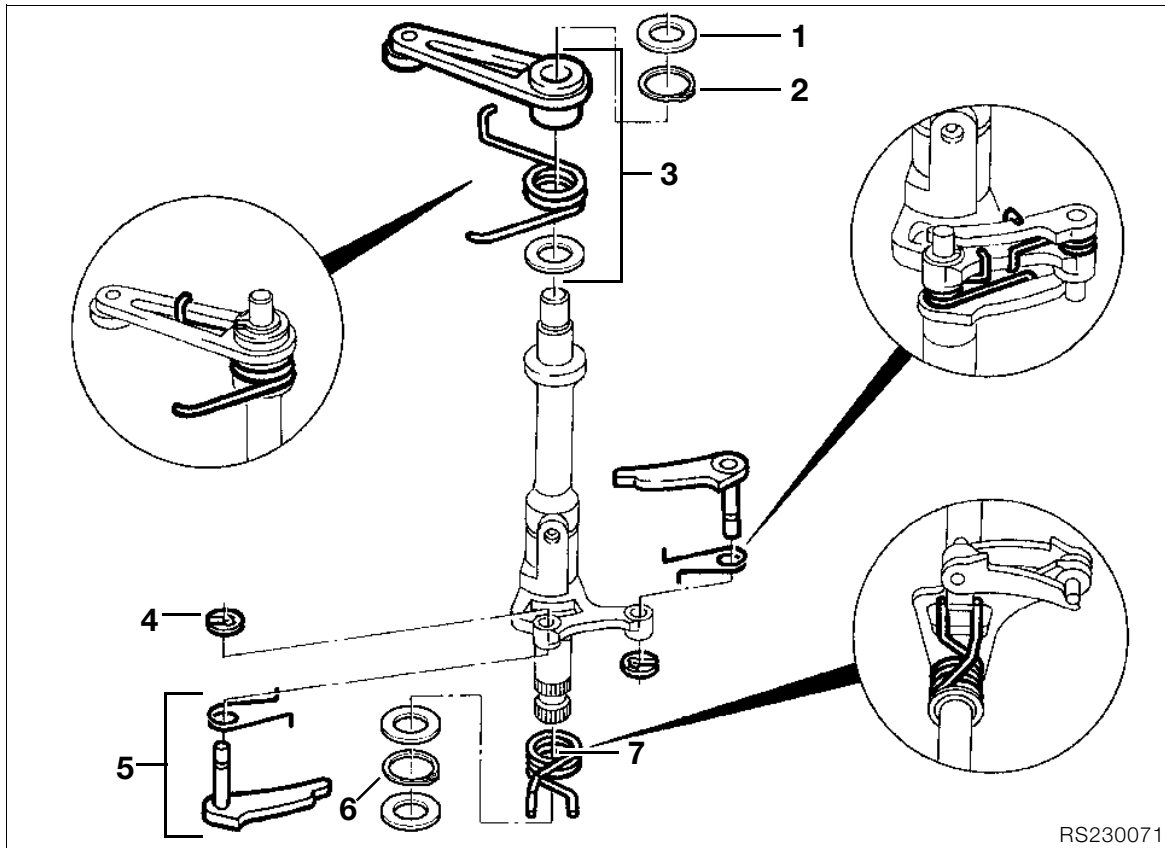

RS230071

#### Removing and installing detent lever

- Remove washer (1).
- Remove keeper (2).
- Remove stop lever (3) with spring and washer.

#### Removing and installing shift pawls

- Remove keeper (4).
- Remove pawl (5) and spring from pawl holder.

#### Removing and installing torsion spring

- Remove retaining ring (6).
- Remove torsion spring (7) with washers.

#### Removing and installing selector shaft seal

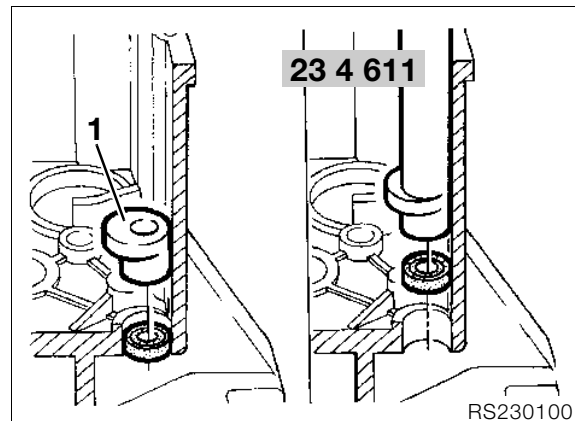

RS230100

- Remove bearing bushing (1) from sliding seat.
- Force out shaft seal with drift, working from the inside
- Drive in the seal with drift, **BMW No. 23 4 611**.
- Install bearing bushing.

### Removing deep-groove ball bearing from selector drum

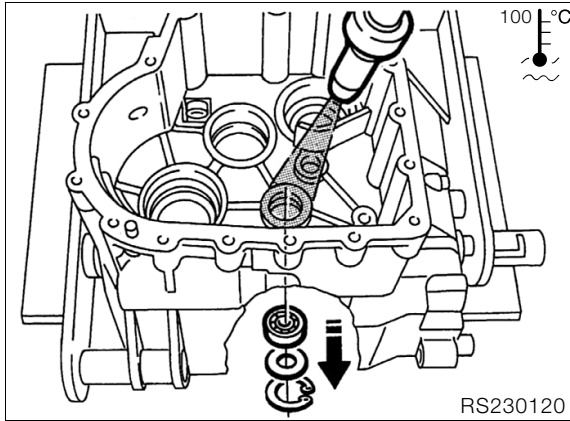

- Remove retaining ring and spacers.
- Heat gearbox housing to 100 °C.
- When heated, deep-groove ball bearing will slide out of seat.

### Shimming selector drum

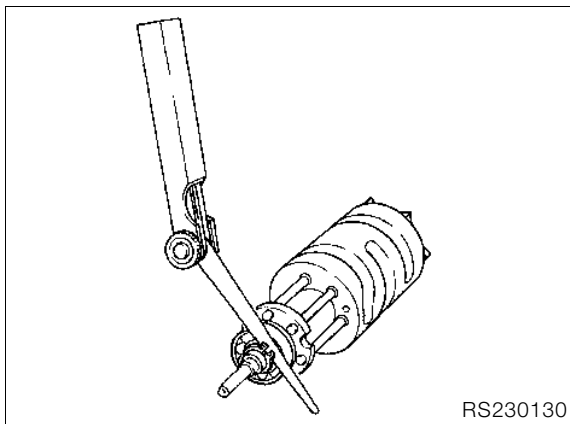

- Fit deep-groove ball bearing.



#### Note:

Retaining ring must locate firmly in groove.

- Install retaining ring, width 1.0 mm (0.039 in).
- Measure clearance with feeler gage.

**End-play:**..... < 0.1 mm (0.0039 in)

- If necessary, use a wider retaining ring to eliminate play.

### Removing taper roller bearing race from input shaft and roller bearing from idler shaft

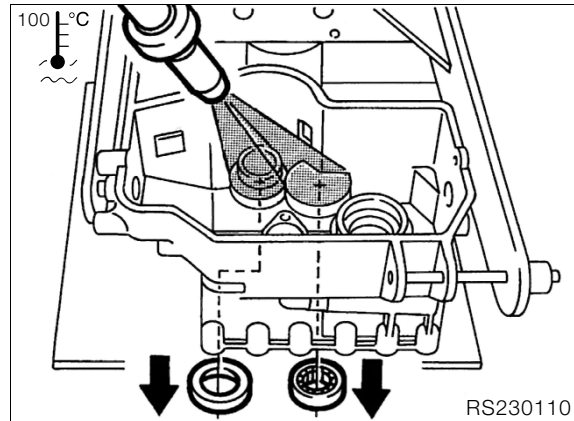

- Heat gearbox housing to 100 °C.
- Depending on tolerance, the bearing races may already slide out of their seat when the housing is heated.
- Pull out taper roller bearing race, if necessary using counter-support, **BMW No. 00 8 562**, and internal puller, **BMW No. 00 8 561**.
- Pull out roller bearing, if necessary with counter-support, **BMW No. 00 8 572**, and internal puller, **BMW No. 00 8 573**.



Installing deep-groove ball bearing on selector drum

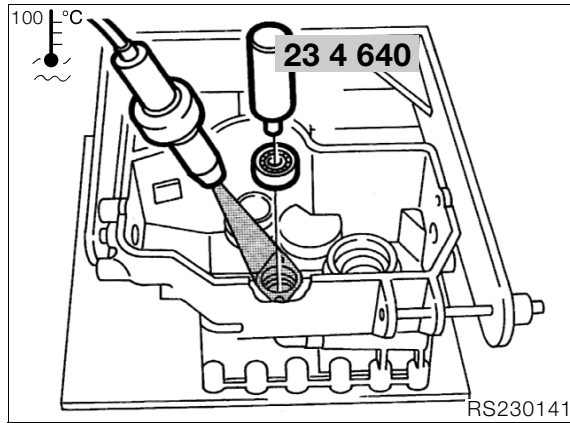

- Heat gearbox housing to 100 °C.
- Using drift, **BMW No. 23 4 640**, insert the deep-groove ball bearing.



**Caution:**

Bearing must be firmly located.

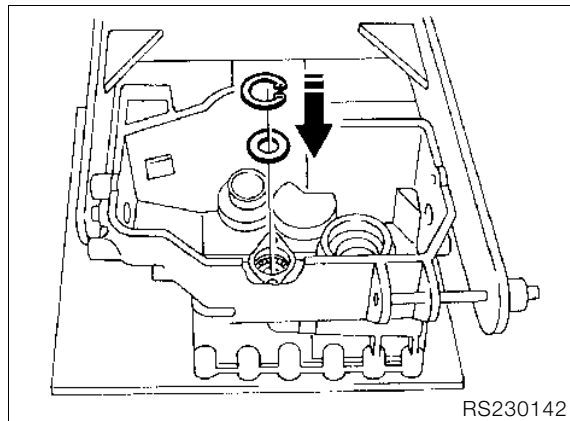

- Shim out bearing (zero backlash)/insert retaining ring.

**End-play:** ..... < 0.1 mm (0.0039 in)

Installing taper roller bearing race on input shaft and roller bearing for idler shaft

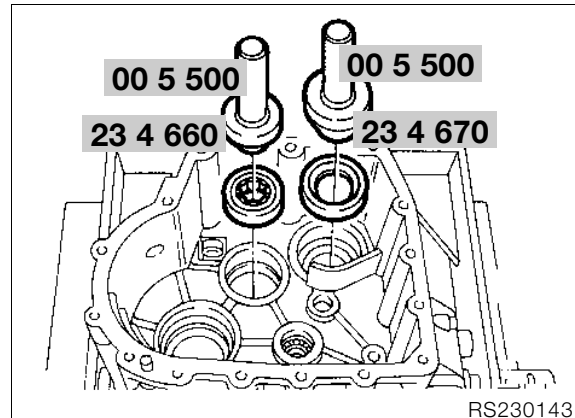

- Heat gearbox housing to 100 °C.
- Insert roller bearing with drift, **BMW No. 23 4 660**, and handle, **BMW No. 00 5 500**.
- Insert taper roller bearing race with drift, **BMW No. 23 4 670**, and handle, **BMW No. 00 5 500**.



**Caution:**

Bearing must be firmly located. Note different diameters of taper roller bearing outer races on input shaft.

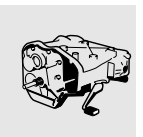

## Removing and installing deep-groove ball bearing and race/roller bearing for idler shaft



### Note:

If defective, the complete idler shaft must be replaced.

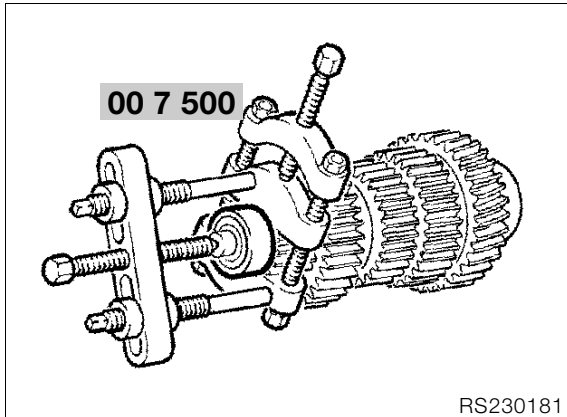

- Pull off deep-groove ball bearing or race/roller bearing with universal puller, **BMW No. 00 7 500**.
- To install deep-groove ball bearing or race/roller bearing, heat to 80 °C and push into position.



### Caution:

If necessary, drive further on by striking inner race only.



### Caution:

Be careful of the sealing washer as you heat the bearing (Clean Bearing); risk of damage.

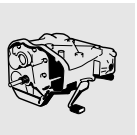

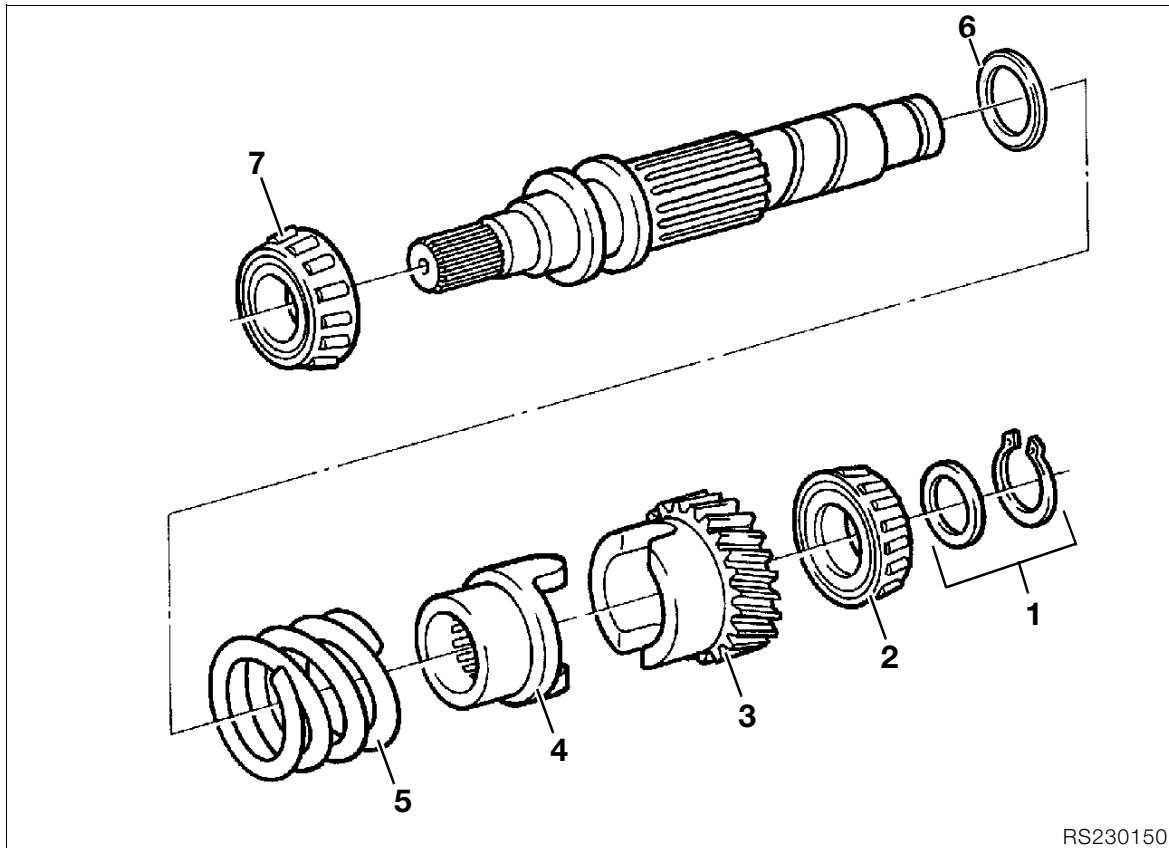

RS230150

### Dismantling/reassembling input shaft

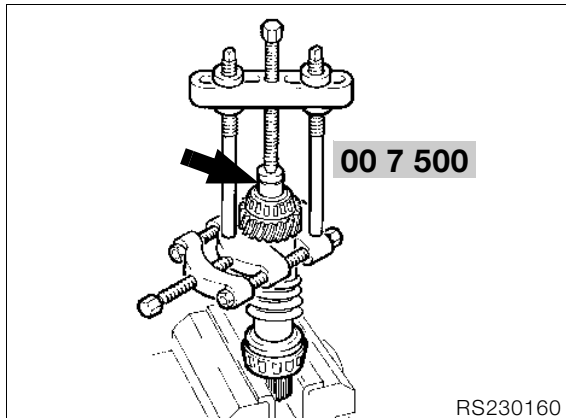

RS230160

- Using a universal puller, **BMW No. 00 7 500**, and pressure head (arrow), pull off spur gear (3) together with taper roller bearing (2).
- Remove washer (6), coil spring (5), pressure piece (4) and spur gear (3).
- Pull off the taper roller bearing (7) in the same way.
- Slide on washer (6) with chamfer facing the end away from the spring.
- Slide coil spring (5), pressure piece (4) and spur gear (3) onto shaft.

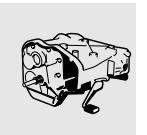

- Clamp input shaft spline in vise with chuck jaws.
- Relieve tension on retaining ring (1), if necessary with gentle blow on bearing inner race.
- Remove retaining ring/washer (1)

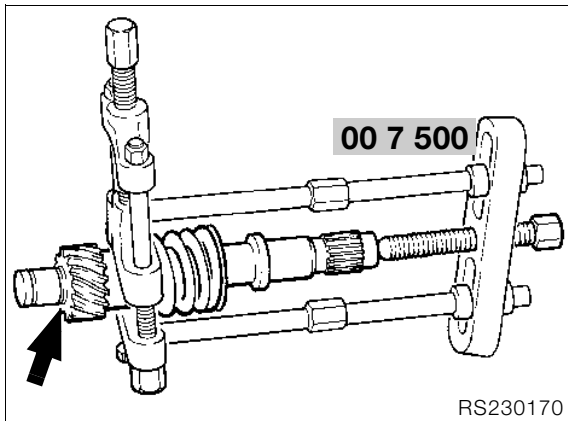

- Use universal puller to tension spur gear against coil spring until entire step (arrow) protrudes from the spur gear.
- To install using a press, press on taper roller bearing cold, or heat it to 80 °C and position it on the input shaft.



**Caution:**

If necessary, drive further on by striking inner race only.

- Install retaining ring/washer (1) in front of taper roller bearing.

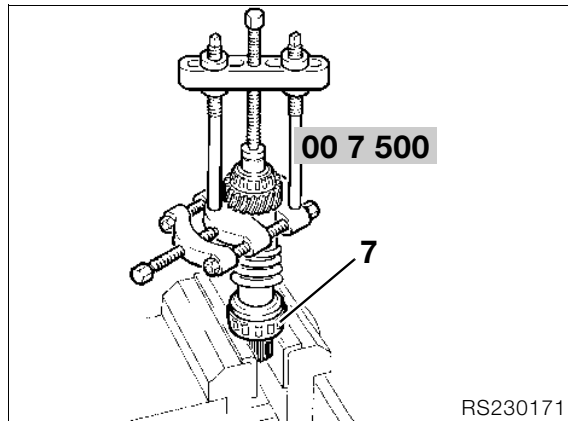

- Fit universal puller under spur gear and press taper roller bearing firmly against retaining ring.



**Caution:**

To prevent measuring errors when installing shims later, zero backlash is required between bearing and retaining ring.

- Using a press, press on taper roller bearing (7) cold, or heat it to 80 °C and position it on the input shaft.



**Note:**

If the input shaft has to be shimmed again, do not install taper roller bearing (7) until measuring work is complete.



**Caution:**

If necessary, drive further on by striking inner race only.

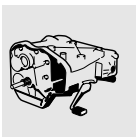

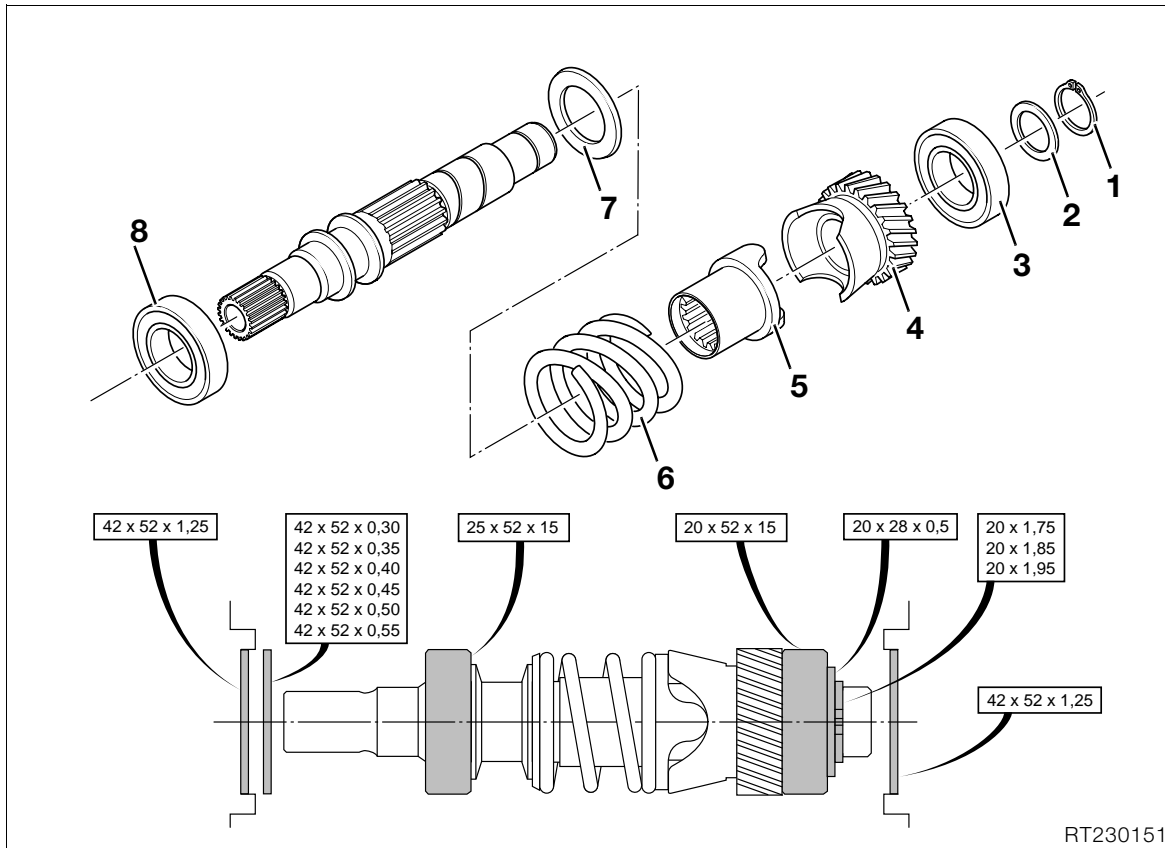

## Disassembling/assembling input shaft (Clean Bearing)



### Note:

The 42x52x1.25 (1.65x2.05x0.049) washers are installed only for the "interim solution". Calculate distances DAn and GAn.  
 If  $DAn = 41.28^{+0.08}$  ( $1.625^{+0.00315}$ )  
 and  $GAn = 100.23^{+0.08}$  ( $3.946^{+0.00315}$ )  
 install a 42x52x1.25 (1.65x2.05x0.049) washer for each.  
 If  $DAn = 39.5^{+0.1}$  ( $1.555^{+0.00393}$ )  
 and  $GAn = 99.0^{+0.1}$  ( $3.898^{+0.00393}$ )  
 do not install 42x52x1.25 (1.65x2.05x0.049) washers.

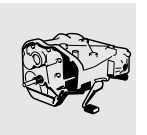

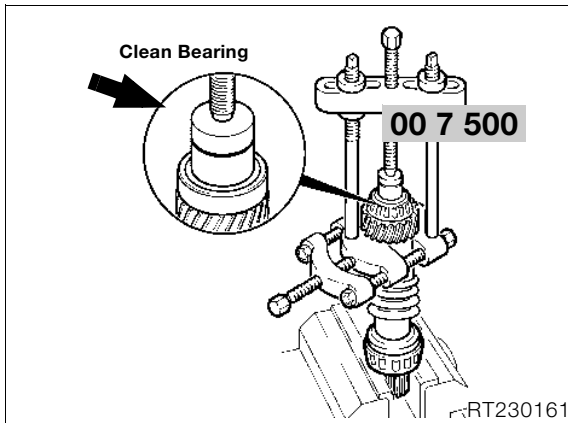

- Clamp splined end of input shaft in vice fitted with jaw protectors.
- Relieve strain on locking ring (1), if necessary lightly tap bearing inner ring to release.
- Remove locking ring and washer (1/ 2).
- Using universal puller, **BMW No. 00 7 500**, and thrust adapter (arrow) to apply uniform pressure, remove spur gear (4) complete with bearing (3).
- Remove washer (7), spring (6), thrust piece (5) and spur gear (4).
- Remove bearing (8) in the same way.
- Slip washer (7) into position with bevel facing away from the spring.
- Slip spring (6), thrust piece (5) and spur gear (4) onto shaft.
- Press on bearing (3) cold, using press, or heat to 80 °C and position on input shaft.

**⚠ Caution:**  
If necessary, drive further on by striking inner race only.

**⚠ Caution:**  
Be careful of the sealing washer as you heat the bearing (Clean Bearing); risk of damage.

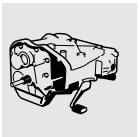

- Install spacer (2).
- Install locking ring (1) and make sure that assembly is free of play.
- Position universal puller under spur gear and seat bearing against locking ring

**⚠ Caution:**  
In order to avoid measuring errors when shims are subsequently installed, make sure that there is no clearance between bearing and locking ring.

- Press on grooved ball bearing (8) cold, using press, or heat to 80 °C (176 °F) and position on input shaft..

**⚠ Caution:**  
If necessary, drive further on by striking inner race only.

**⚠ Caution:**  
Be careful of the sealing washer as you heat the bearing (Clean Bearing); risk of damage.

- **By preference**, press on grooved ball bearing (8) cold, using press, or alternatively heat to 80 °C (176 °F) and position on input shaft.

**📄 Note:**  
If input shaft has to be shimmed, do not install grooved ball bearing (8) until all measurements have been completed.

**⚠ Caution:**  
Be careful of the sealing washer as you heat the bearing (Clean Bearing); risk of damage.

**⚠ Caution:**  
When seating components on the input shaft while removed from engine, apply pressure to the inner ring only.

**⚠ Caution:**  
If the Clean Bearing input shaft is installed, do not strike shaft/bearing as otherwise, the bearing might no longer be correctly seated on the locking ring.

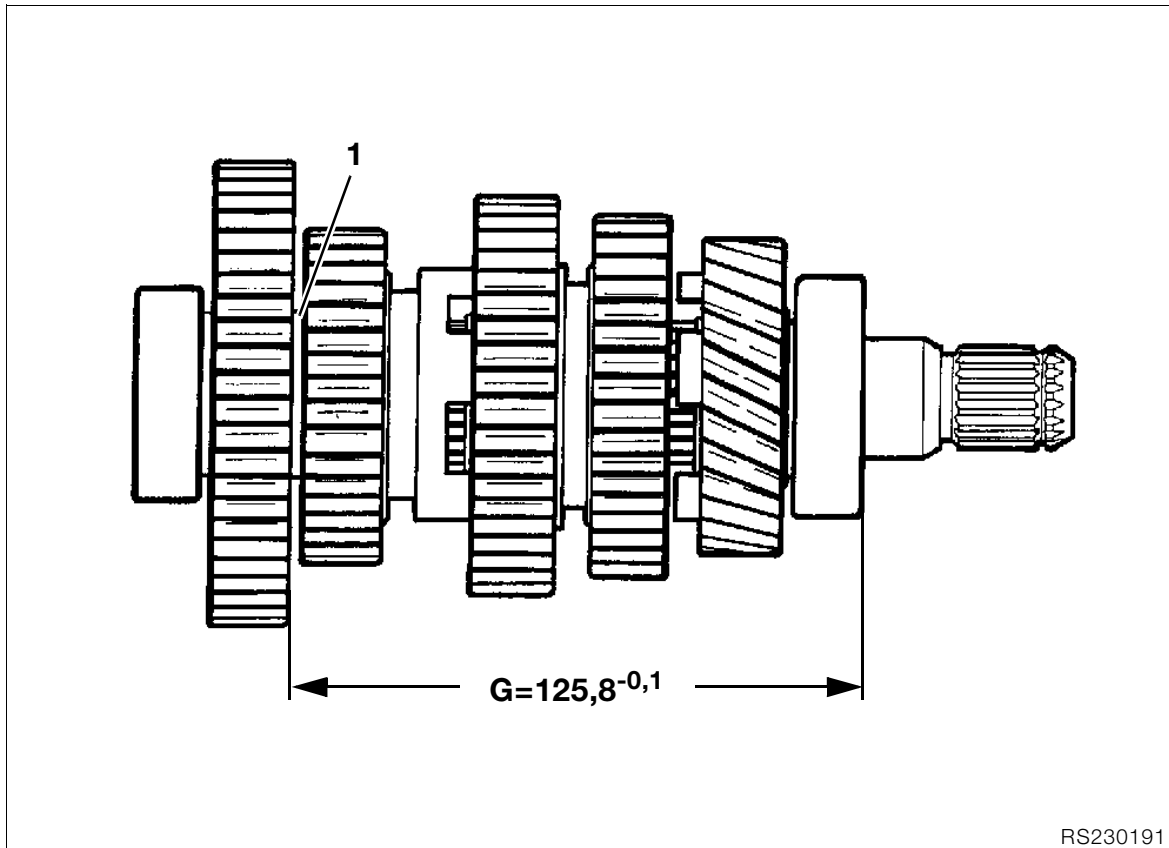

RS230191

#### Dismantling/reassembling output shaft

- **[1993 model year]** When determining total distance G, include spacing washer (1); if necessary, adjust distance G with shims.
- **[from 1994 model year]** Measurement and adjustment of G are no longer needed.

#### Removing deep-groove ball bearing

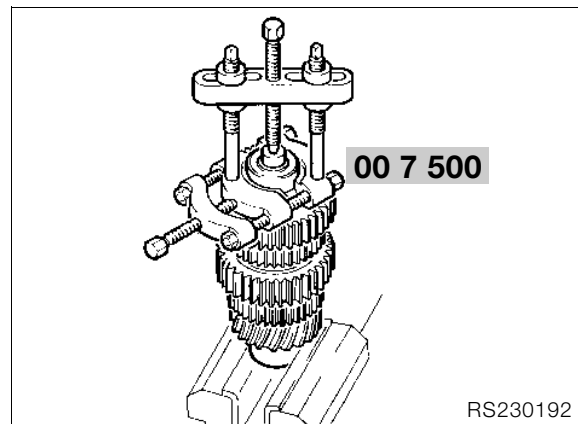

RS230192

- Clamp the output shaft into a vise with soft jaws.
- Using universal puller, **BMW No. 00 7 500**, and pressure head, pull off the deep-groove ball bearing.

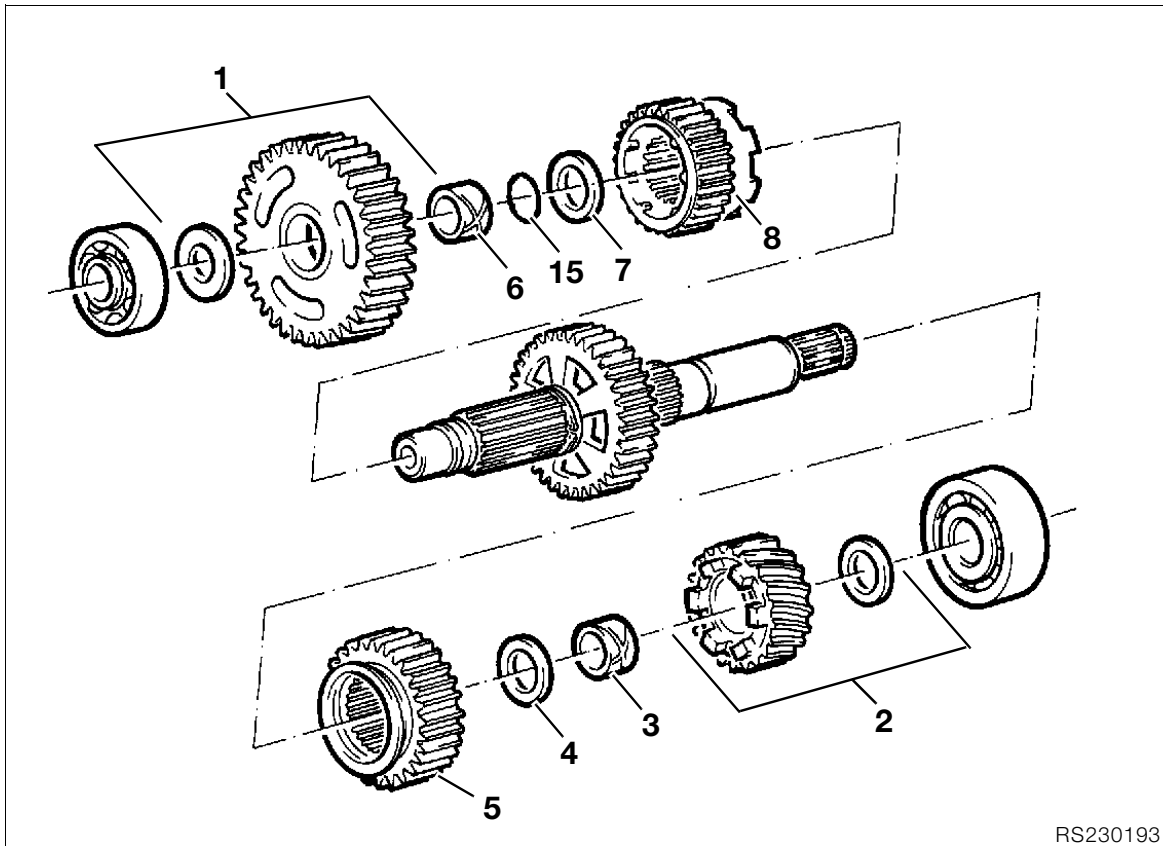

RS230193

#### Removing spur gears

- Remove spur gear for 1st (1) and 5th gear (2) with thrust washers.

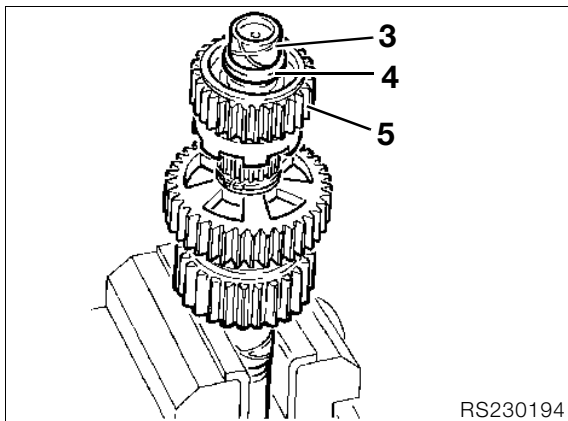

RS230194

- Remove thrust washer (4) and bearing bushing (3) with spur gear for 3rd gear (5).
- **[from 1994 model year on]** take off the O-ring (15).
- Remove spacer (7) and bearing bushing (6) with spur gear for 4th gear (8).

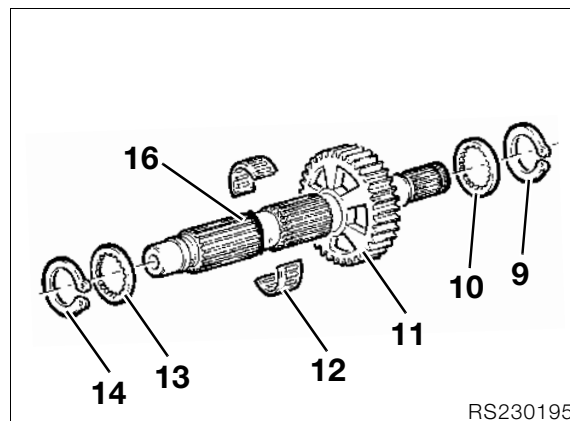

RS230195

- Remove retaining ring (9).
- Remove toothed disk (10).
- Remove spur gear for 2nd gear (11).
- Remove split needle cage (12).
- Remove toothed disk (13) and retaining ring (14).
- **[from 1994 model year on]** Take off O-ring (16).



## Installing spur gears

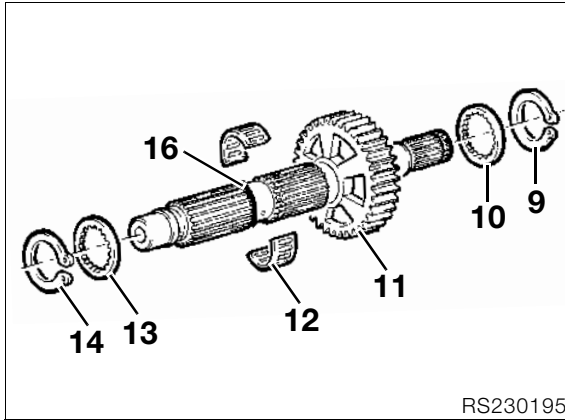

- Slide toothed disk (13) up to front of bearing seat.
- Slide on retaining ring (14) and locate in groove.
- **[from 1994 model year on]** Push O-ring (16) onto seat.



### Caution:

Use a new O-ring.

- Fit split needle cage (12) to output shaft.
- First slide spur gear for 2nd gear (11) over needle cage, with apertures at top.
- Install toothed disk (10), then retaining ring (9).

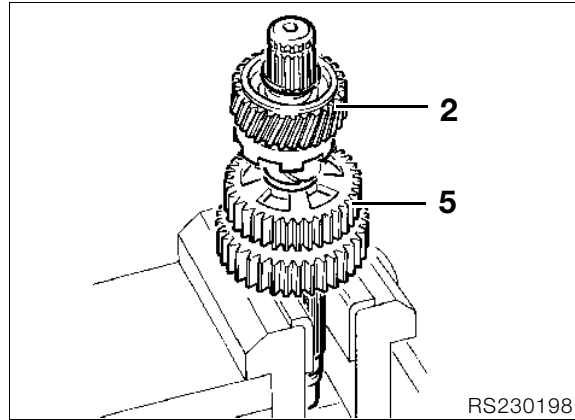

- Clamp output shaft into vise with soft jaws; the drive shaft splines must face upwards.
- Slide spur gear for 3rd gear (5) onto output shaft with apertures facing upwards.
- Fit thrust washer.
- Heat the wide race (3) to 80 °C and push it onto the output shaft as far as the support washer.
- Fit spur gear for 5th gear (2) with dogs facing downwards.
- Fit thrust washer.
- Press on grooved ball bearing cold, using press, or heat to 80 °C and position on input shaft.



### Caution:

If necessary, drive further on by striking inner race only.



### Caution:

Be careful of the sealing washer as you heat the bearing (Clean Bearing); risk of damage.

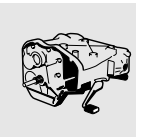

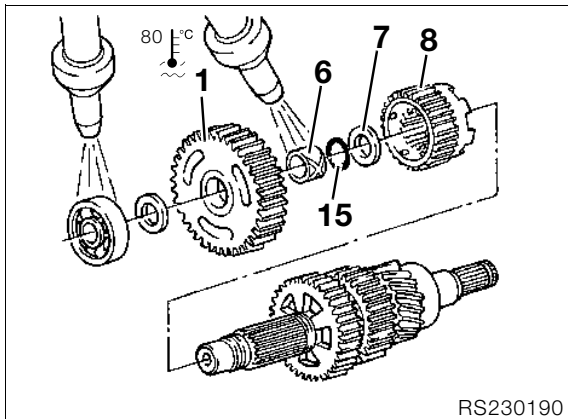

- Invert output shaft in vise with spline tracks facing downwards.
- Slide spur gear for 4th gear (8) onto output shaft with dogs facing downwards.
- Fit spacer (7).
- **[from 1994 model year on]** Push O-ring (15) onto seat.

**⚠ Caution:**  
Use a new O-ring.

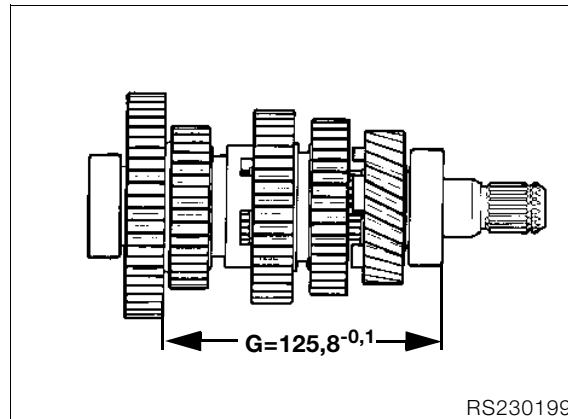

- **[1993 model year]** Measure distance G and shim as necessary.
- **[1993 model year]** Heat the narrow race (6) to 80 °C and push it onto the output shaft as far as the spacing washer.
- **[from 1994 model year on]** Heat the narrow race (6) to 80 °C and push it on flush with the step in the shaft.
- Slide spur gear for 1st gear (1) onto output shaft with aperture and shift teeth facing downwards.
- Fit thrust washer.
- Press on grooved ball bearing cold, using press, or heat to 80 °C and position on input shaft.

**⚠ Caution:**  
If necessary, drive further on by striking inner race only.

**⚠ Caution:**  
Be careful of the sealing washer as you heat the bearing (Clean Bearing); risk of damage.



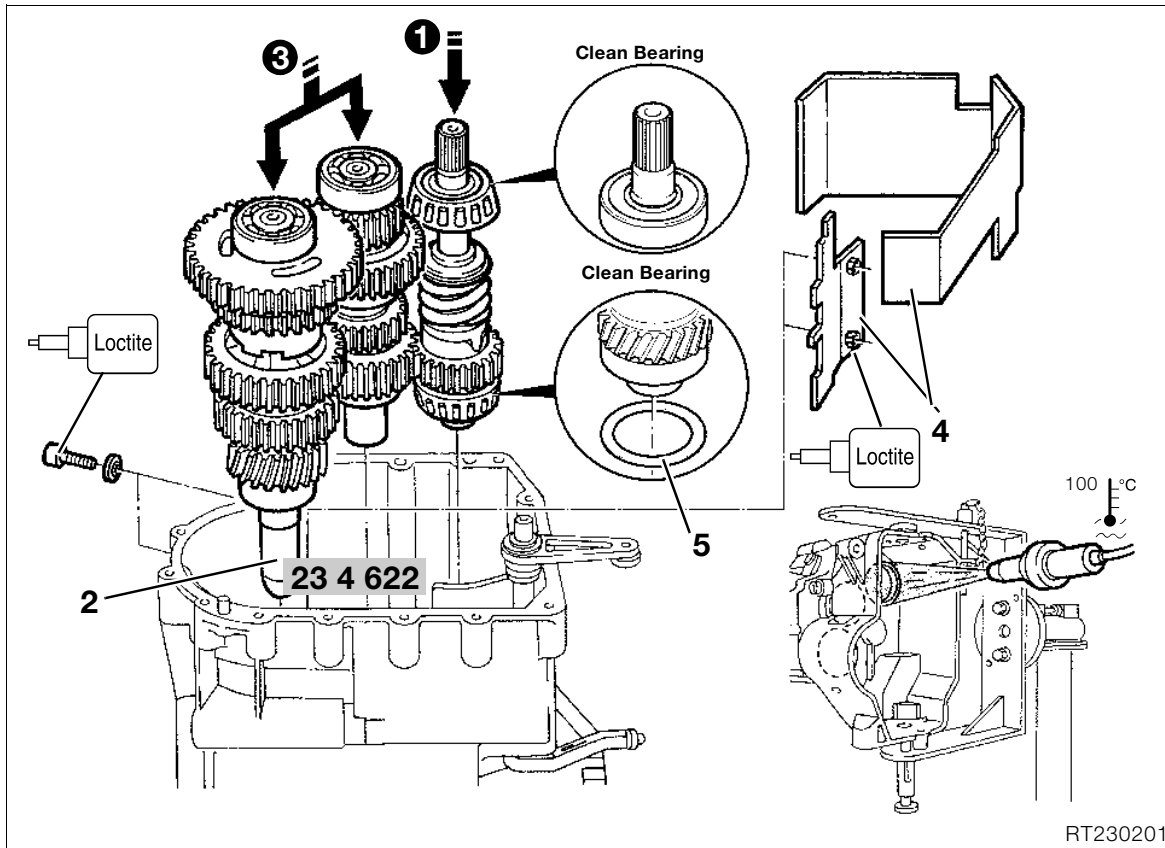

## Installing gearbox shafts



### Note:

If the input shaft has to be shimmed, do not install the input-side bearing until all measurements have been completed.

- Heat the output shaft bearing point to 100 °C.
  - **[1993 model year]** First insert the input shaft (1).
  - Push sliding sleeve (2), **BMW No. 23 4 622**, onto the output shaft.
  - **[1993 model year]** Insert the idler shaft and output shaft (3) into the gearbox housing together.
  - **[Clean Bearing]** Install spacer (5).
- page 23.22
- **[from 1994 model year on]** Insert the input, idler and output shafts into the gearbox housing together.
  - With gentle blows of a plastic-faced hammer, check that bearing is firmly seated.



### Caution:

Do not strike the seat of a Clean Bearing shaft, as otherwise the bearing might no longer be correctly seated on the locking ring.

- Install oil baffle plates (4).



### Caution:

After installation of the oil baffle plates, turn the gears and check for ease of movement..



### Tightening torque:

Oil baffle plate retaining screws  
(clean thread + Loctite 573, also apply Loctite 573 to the sealing face on the oil baffle plate where it contacts the gearbox housing) ..... 9 Nm

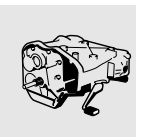

## Removing and installing output shaft seal

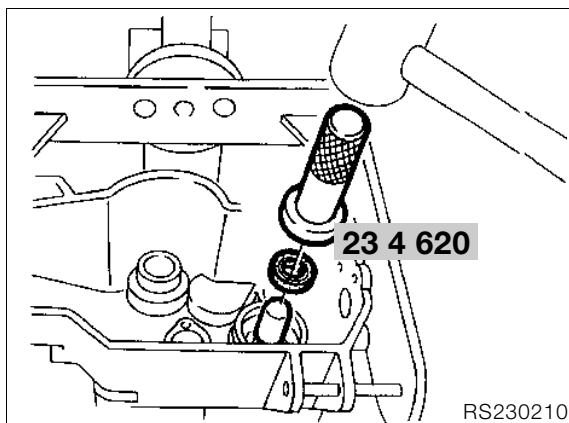

- Force out shaft seal with drift, working from the inside
- Drive in the new shaft seal with drift and sliding sleeve, **BMW No. 23 4 620**.

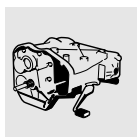

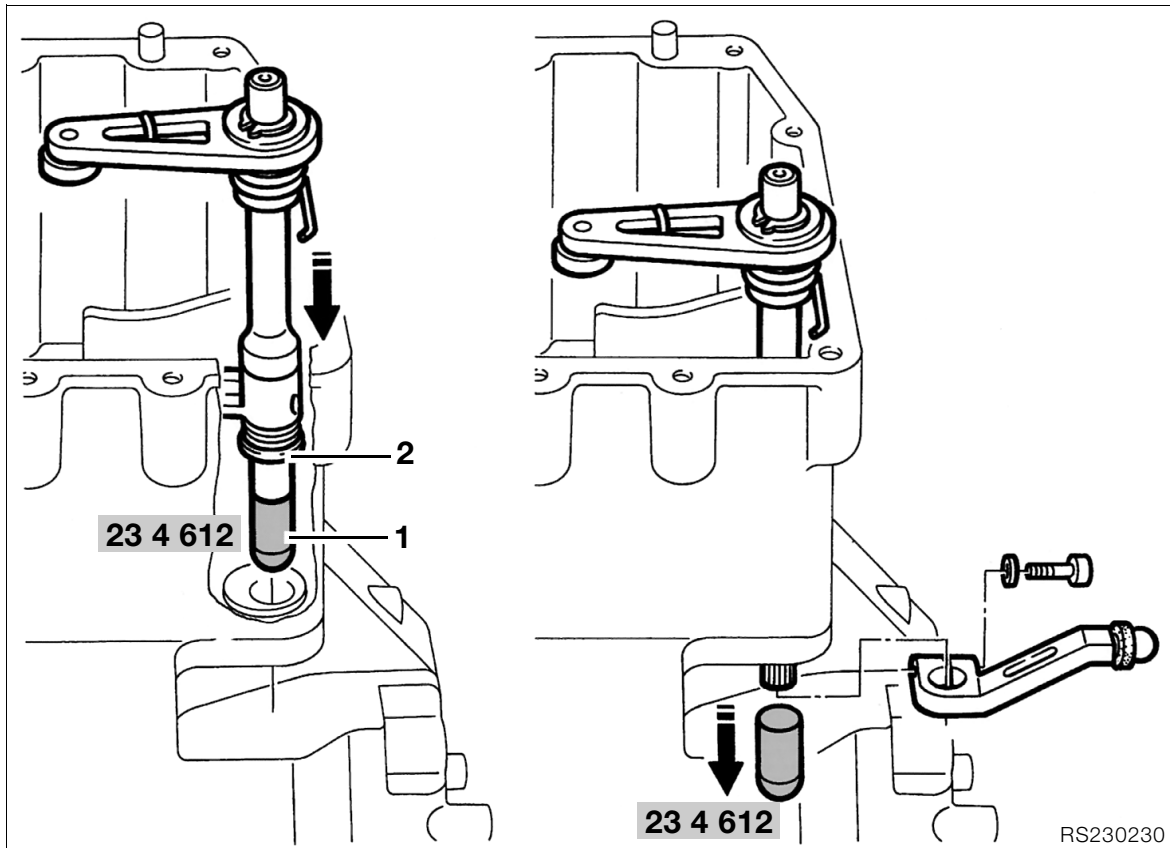

### Installing selector shaft

- Insert selector shaft with sliding sleeve (1), **BMW No. 23 4 612.**

 **Note:**  
Note washer (2).

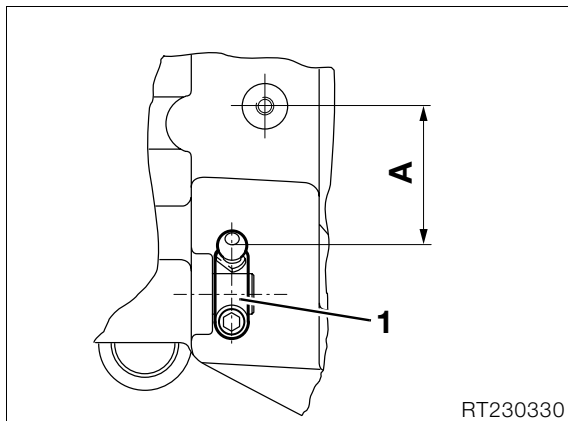

- **[RT/GS]** Attach gear shift pedal (1) horizontally, making sure that distance A is correct.

**Distance A:**..... 51.9 ±1.8 mm (2.043 ±0.07 mm)

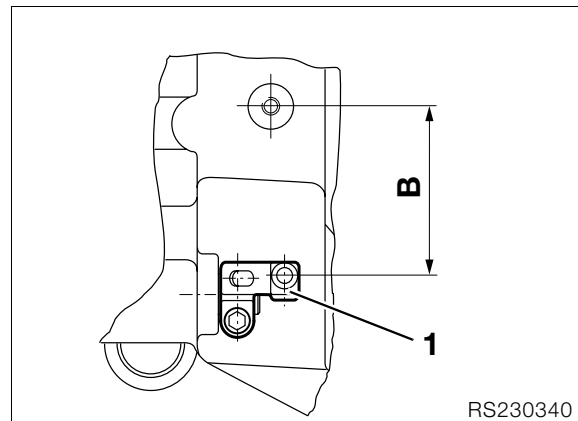

- **[RS/R]** Attach gear shift pedal (1) horizontal, noting distance B.

**Maß „B“:**..... 61.2 ±1.8 mm (2.409 ±0.07 mm)

 **Tightening torque:**  
Gear shift pedal..... 9 Nm

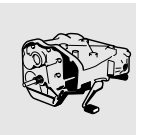

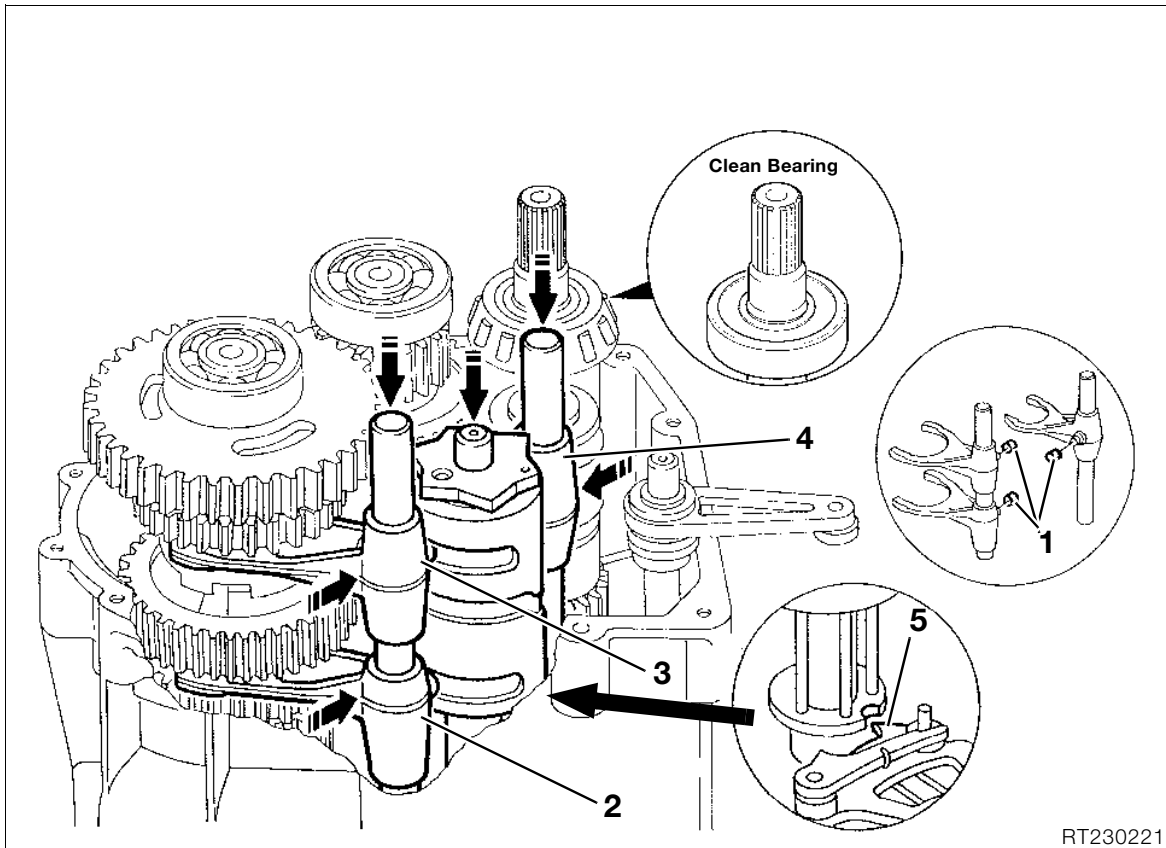

### Installing selector forks



**Note:**

Fit rollers (1) on guide pins and apply some grease to the pins.

- Install selector fork (2) for 5th gear in underside of output shaft with short end of guide facing upwards.
- Install selector fork (3) for 1st and 2nd gears with central guide in top of output shaft.
- Install selector fork (4) for 3rd and 4th gears in idler shaft with short end of guide pointing downwards.

### Installing selector drum

- Swing the selector forks over to the edge of the housing.
- Install selector drum with its recess facing the selector shaft pawl (5).



**Note:**

If necessary, secure needle rollers with grease.

- Insert selector fork guide pins into selector drum.
- Install shift fork shafts.

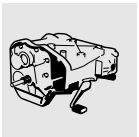

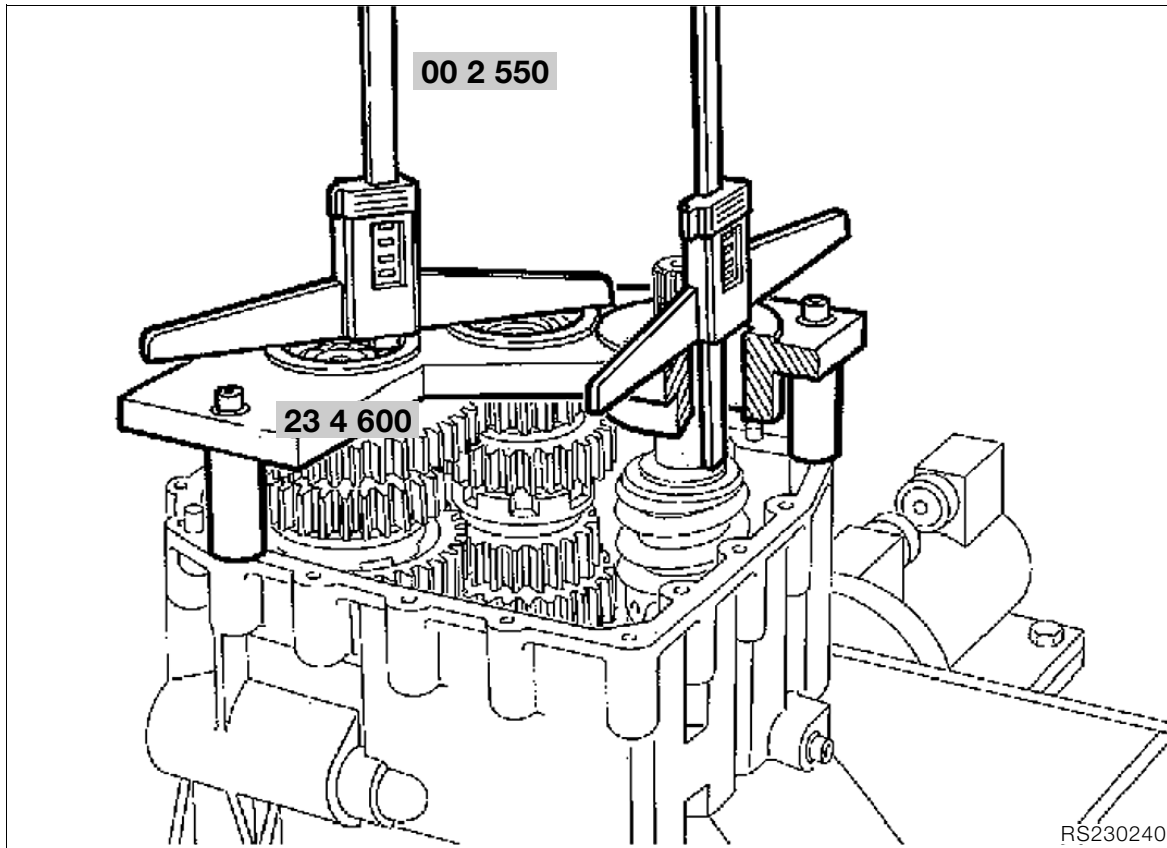

RS230240

## Shimming gearbox shafts

### Measuring shaft bearing play

- Bolt gearbox measuring plate, **BMW No. 23 4 600**, to the sealing face, which must be clean.

**Tightening torque:** ..... 9 Nm

- Using depth gauge, **BMW No. 00 2 550**, measure distance between measuring plate and outer race of deep-groove ball bearing.



### Note:

Before measuring, strike the shaft in question (output/idler shaft) with a plastic-faced hammer (dead action) to force it down onto the base of its seat; then measure without delay.



### Caution:

Do not strike the seat of a Clean Bearing shaft, as otherwise the bearing might no longer be correctly seated on the locking ring.

- Measure distance between measuring plate and bearing collar on input shaft.
  - Enter all measurements in a table.
- ➔ see page 23.28

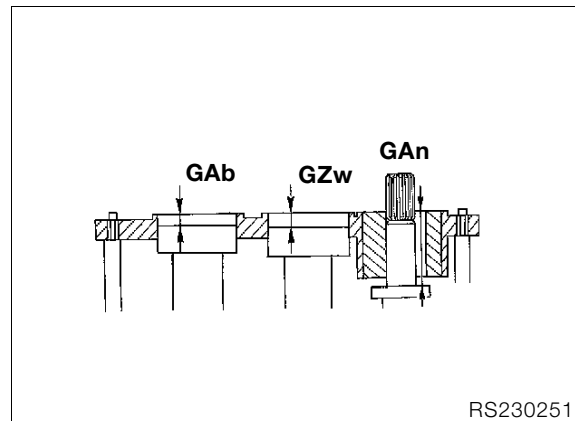

RS230251

### Key to abbreviations used in measurements:

- MAB = Dimension between measuring plate and output shaft  
 MZw = Dimension between measuring plate and idler shaft  
 MAn = Dimension between measuring plate and input shaft  
 H = Height of measuring plate

### Overall dimensions:

- GAb ..... = H – MAB  
 GZw ..... = H – MZw  
 GAn ..... = H – MAn

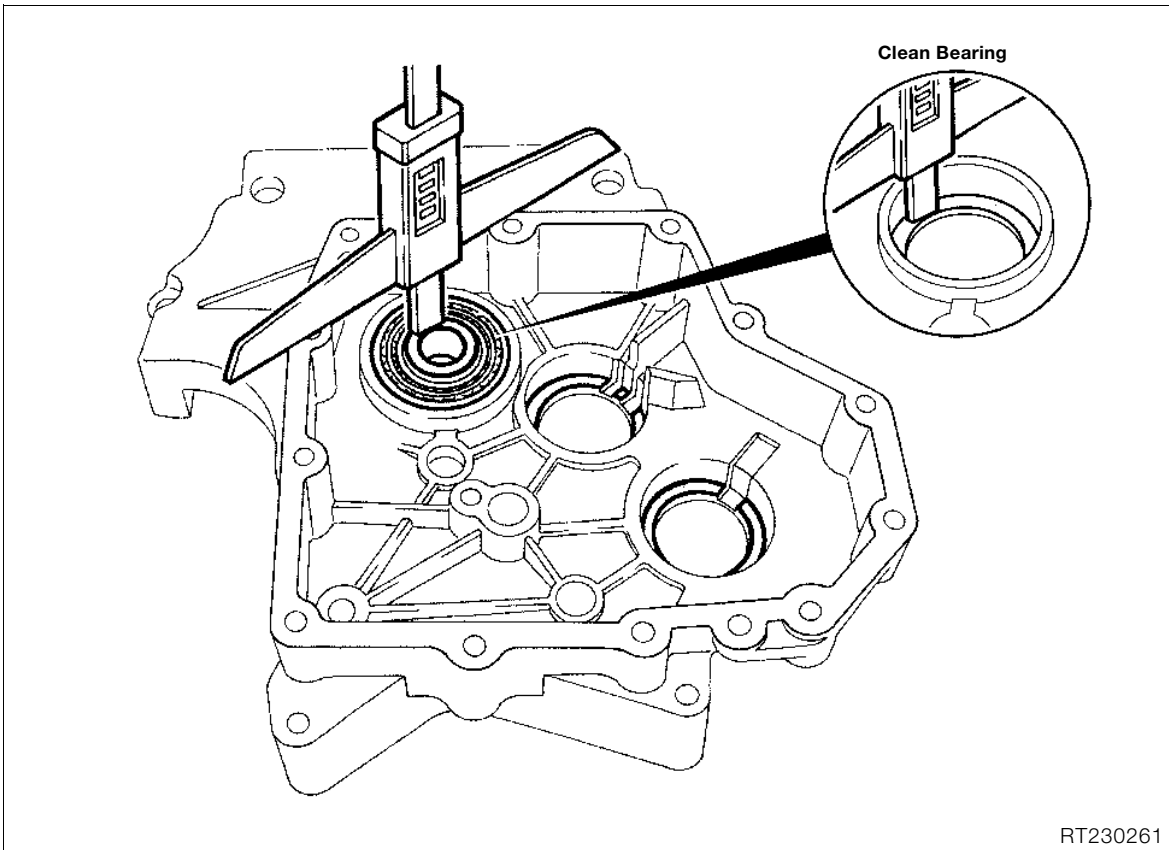

RT230261

**Measuring gearbox cover**

- Measure dimension between gearbox cover joint face and base of bearing seat, taper roller bearing to bearing inner race.

**⚠ Caution:**

Always measure taper roller bearing with oil baffle plate removed. The oil baffle plate is slightly corrugated, which can falsify the measurement.

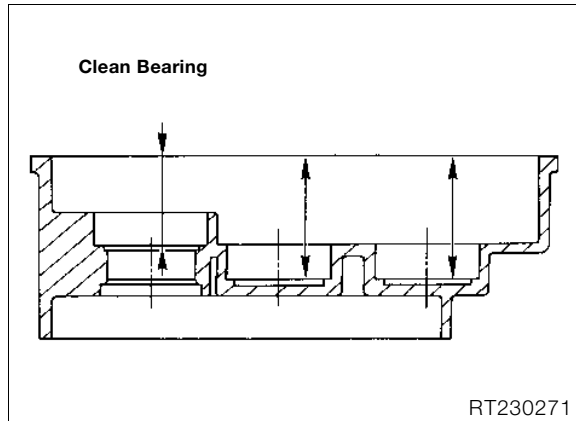
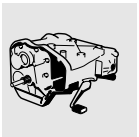

RT230271

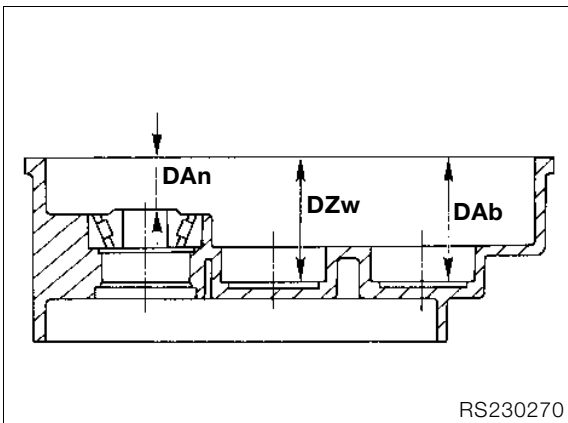

RS230270

**Key to abbreviations used in measurements:**

- DAb..... = Cover dimension, output shaft
- DZw..... = Cover dimension, idler shaft
- DAn..... = Cover dimension, input shaft

- Enter all measurements in a table
- ➡ see page 23.28.



## Shimming the gearbox shafts (without Clean Bearing)

### Example

Dimensions in millimeters	Output shaft "Ab"	Idler shaft "Zw"	Input shaft "An"
H	60,00 mm (2.362 in)	60,00 mm (2.362 in)	60,00 mm (2.362 in)
- M (measure!)			
= G			
D (measure!)			
- G			
= clearance without spacers			
- specified end float	0,05 – 0,15 mm (0.00196...0.0059 in)	0,05 – 0,15 mm (0.00196...0.0059 in)	
+ permitted preload			0,20 mm (0.00787 in)
= thickness of spacers			



#### Caution:

To check friction coefficient of taper roller bearings on input shaft, only install input shaft in gearbox.  
Bearings must be oiled.

## Shimming the gearbox shafts (with Clean Bearing)

### Example

Dimensions in millimeters	Output shaft "Ab"	Idler shaft "Zw"	Input shaft "An"
H	60,00 mm (2.362 in)	60,00 mm (2.362 in)	60,00 mm (2.362 in)
- M (measure!)			
= G			
D (measure!)			
- G			
= Clearance without shims and input-shaft bearing			
- specified end float	0,05 – 0,15 mm (0.00196...0.0059 in)	0,05 – 0,15 mm (0.00196...0.0059 in)	0,05 – 0,15 mm (0.00196...0.0059 in)
= Bearing (input shaft) and shim thickness			

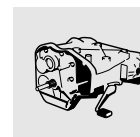

## Removing and installing taper roller bearing race

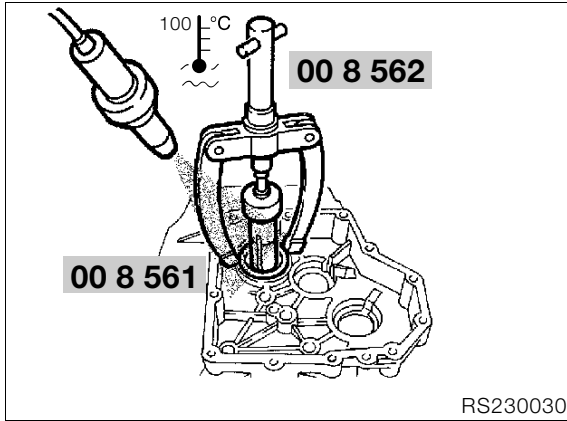

- Gearbox cover temperature at bearing seat 100 °C.
- Depending on tolerance, the bearing shell may already slide out of its seat when the housing is heated. If necessary, pull bearing race out with Kukko counter-support, **BMW No. 00 8 562**, and internal puller, **BMW No. 00 8 561**.
- Remove spacing washers/oil baffle plate.

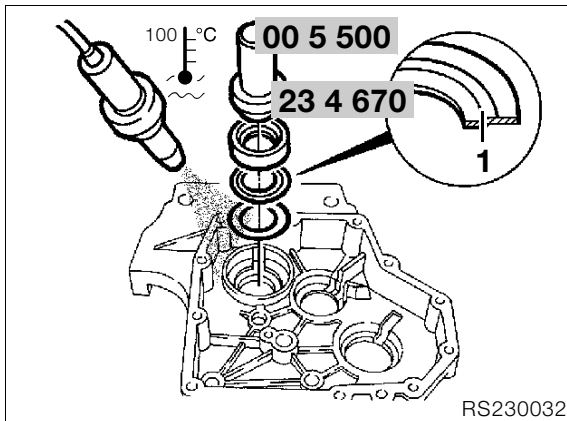

- Gearbox cover temperature at bearing seat 100 °C.
- Place shims of the calculated thickness in the gearbox cover/include the oil retaining plate (1).
- Using drift, **BMW No. 23 4 670**, and handle, **BMW No. 00 5 500**, insert the bearing race in the gearbox cover while it is still hot.

## Checking friction coefficient of input shaft taper roller bearing

- Install gearbox cover

**Tightening torque:**  
Retaining screws..... 10 Nm

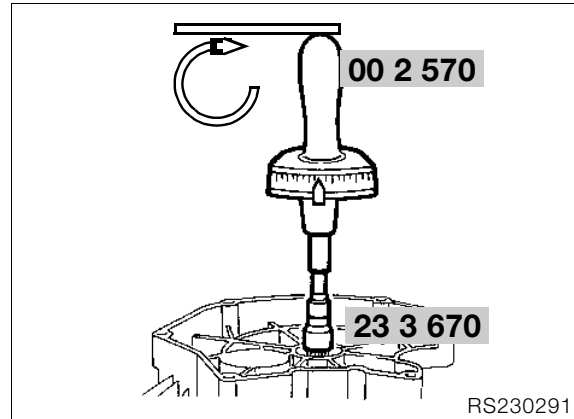

- Using adapter, **BMW No. 23 3 670**, and friction meter, **BMW No. 00 2 570**, check friction in the input shaft taper roller bearing by turning at app. 1 revolution per second.

### **Caution:**

To check friction coefficient of taper roller bearing on input shaft, only install the input shaft in the gearbox.  
Bearings must be oiled.

### **Friction value:**

Preload 0.2 mm (0.00787 in) =  
friction value 0.5 – 1.0 Nm

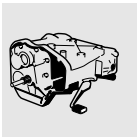

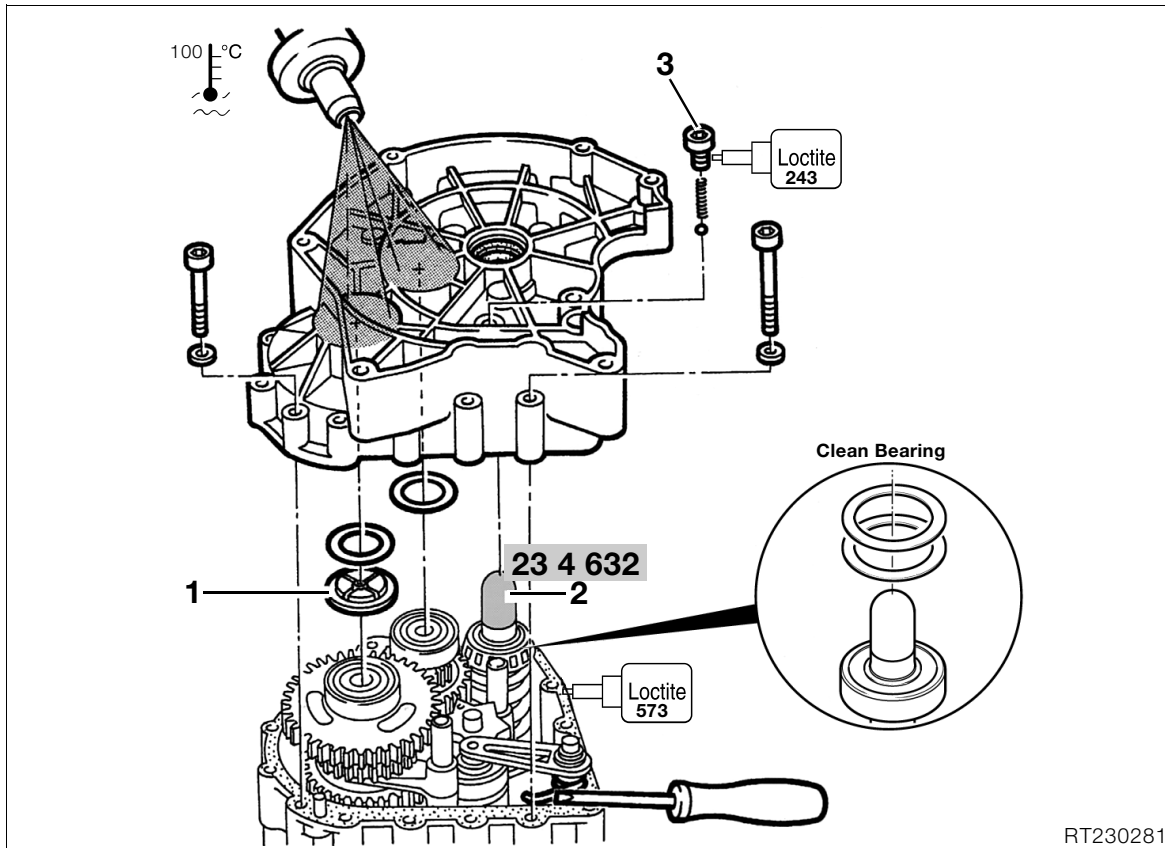

RT230281

## Installing gearbox cover

- Slightly grease the shims of the calculated thickness for the idler and output shafts (include oil trap plate (1) in the shim thickness) and place then flush on the deep-groove ball bearing.
- Place sliding sleeve (2), **BMW No. 23 4 632**, on the input shaft.
- Apply a thin coat of **Loctite 573** to the housing joint face, which must be clean and free from grease.
- Heat the gearbox cover to 100 °C.
- Fit gearbox cover/insert selector shaft and selector drum in bearings.
- Preload arm of stop lever spring, attach and completely fit gearbox cover.

### Tightening torque::

Retaining screws on gearbox cover ..... 10 Nm  
 Neutral detent screw  
 (clean thread + Loctite 243)..... 13 Nm

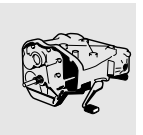

### Caution:

Arm of spring at clutch end of gearbox housing must be under preload and must not be displaced towards the output end of housing.

- Tighten down gearbox cover.
- Insert idle stop (3) (ball and spring) into gearbox.
- Insert the neutral detent screw with **Loctite 243**.

## Removing and installing input shaft seal at housing cover end

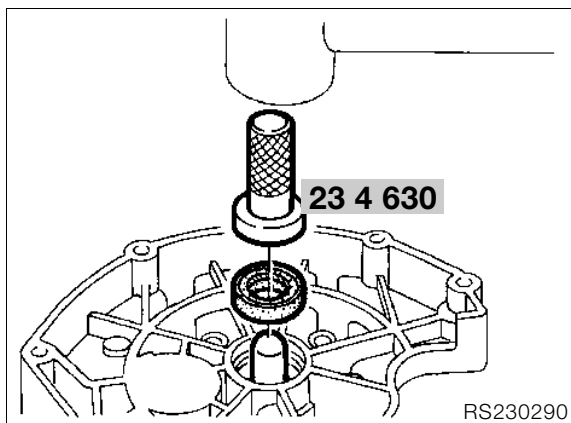

- Drive out shaft sealing ring with punch from the inside.
- Drive in the new sealing ring with a drift and sliding sleeve, **BMW No. 23 4 630**.

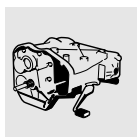

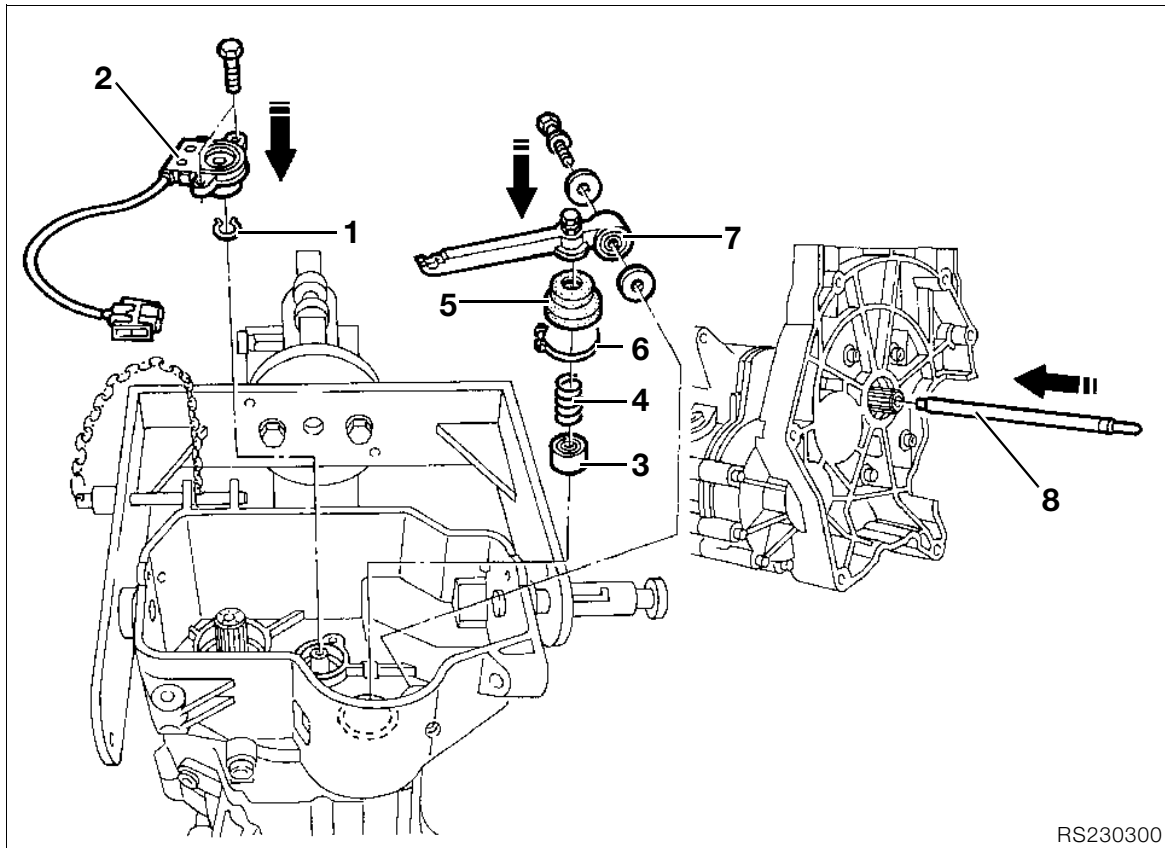

RS230300

## Completing assembly of gearbox

- Install retaining ring (1) in selector drum.
- Install neutral switch (2).
- If applicable, install gear display switch



### Caution:

Make sure that the O-ring is in good condition.

- Install clutch piston (3), coil spring (4) and sleeve (5).
- Attach hose clip (6).
- Install clutch lever (7).
- Install thrust rod (8).



### Tightening torque:

Retaining screw on clutch lever..... 18 Nm

### Lubrication points:

Splines on clutch plate and input shaft  
 Diaphragm spring contact face at clutch housing  
 Diaphragm spring contact face at driven plate  
 Release lever adjusting screw contact face at clutch piston.

**Lubricant:**..... Optimoly MP3 paste

### Oil fill quantity to lower edge of filler screw:

API GL 5 SAE 90 ..... 1.0 l (1.76 Imp. pints)

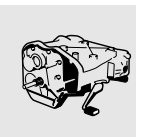

## Installing gearbox

- Check centering of driving plate with centering pin, **BMW No. 21 3 680**.

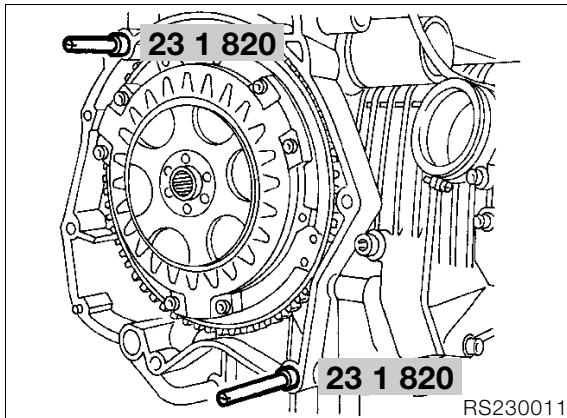

- Screw in guide pins (oiled), **BMW No. 23 1 820**, and push the gearbox carefully on to them.



### ! Tightening torque:

Gearbox to engine block ..... 22 Nm

- Installation is performed in the reverse order to the removal procedure.

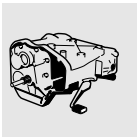

# 31 Front fork

<b>Contents</b>	<b>Page</b>
<b>Technical Data</b> .....	3
<b>Removing and installing telescopic fork</b> .....	7
Removing and installing telescopic fork without fork bridge .....	7
[RS] Removing and installing fork bridge .....	8
[GS/R/RT] Removing and installing fork bridge .....	8
Removing and installing pot-type joints .....	9
Removing and installing ball thrust bearing .....	10
Removing and installing slider tube bridge .....	11
Removing and installing ball joint .....	11
[RS] Checking ball joint friction .....	11
[GS/R/RT] Checking ball joint/ball thrust bearing friction .....	11
Assembly specification for telescopic fork: .....	12
<b>Dismantling/reassembling telescopic fork</b> .....	13
Dismantling telescopic fork .....	13
Assembling telescopic fork .....	14
<b>Measuring telescopic fork</b> .....	14
Check slider tube bridge .....	14
Checking runout of fixed tube .....	14
<b>Removing and installing leading link</b> .....	15
<b>Dismantling/reassembling leading link</b> .....	15
<b>Removing and installing front suspension strut</b> .....	16
<b>[R] Removing and installing steering damper</b> .....	16
Removing and installing ball head .....	16
Checking the steering damper .....	16



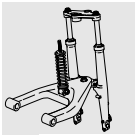



Technical Data		R 1100 RS
<b>Front suspension</b>		
Type	BMW Telelever with external suspension strut	
<b>Telescopic fork</b>		
Front wheel caster in normal-load position (with rider weighing 85 kg (187.425 lb))	mm (in)	111 (4.37)
Steering lock angle	°	32
Total suspension travel	mm (in)	120 (4.7244)
Fixed tube surface		Hard chrome plate
Extl. dia. of fixed fork tubes	mm (in)	35,0 (1.3779)
Maximum permissible runout of fixed fork tube	mm (in)	0,4 (0.01574)
Telescopic fork oil – approved grades		BMW telescopic fork oil
Fill quantity in each fork leg	l (Imp. pints)	0.470 (0.827)
<b>Suspension strut</b>		
Type	Suspension strut with coil spring and twin-tube, gas-filled shock absorber	



Technical Data		R 1100 RT
<b>Front suspension</b>		
Type	BMW Telelevr with external suspension strut	
<b>Telescopic fork</b>		
Front wheel caster in normal-load position (with rider weighing 85 kg (187.425 lb))	mm (in)	122 (4.803)
Steering lock angle	°	34
Total suspension travel	mm (in)	120 (4.7244)
Fixed tube surface		Hard chrome plated
Extl. dia. of fixed fork tubes	mm (in)	35,0 (1.3779)
Maximum permissible runout of fixed fork tube	mm (in)	0,4 (0.01574)
Telescopic fork oil – approved grades		BMW telescopic fork oi
Fill quantity in each fork leg	l (Imp. pints)	0.470 (0.827)
<b>Suspension strut</b>		
Type	Suspension strut with coil spring and twin-tube, gas-filled shock absorber	

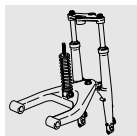

Technical Data		R 850 GS	R 1100 GS
<b>Front suspension</b>			
Type		BMW Telelever with external suspension strut	
<b>Telescopic fork</b>			
Front wheel caster in normal-load position (with rider weighing 85 kg (187.425 lb))	mm (in)	115 (4.5275)	115 (4.5275)
Steering lock angle	°	42	42
Total suspension travel	mm (in)	190	190
Fixed tube surface		Hard chrome plated	Hard chrome plated
Extl. dia. of fixed fork tubes	mm (in)	35,0 (1.3779)	35,0 (1.3779)
Maximum permissible runout of fixed fork tube	mm (in)	0,4 (0.01574)	0,4 (0.01574)
Telescopic fork oil – approved grades		BMW telescopic fork oil	BMW telescopic fork oil
Fill quantity in each fork leg	l (Imp. pints)	0.470 (0.827)	0.470 (0.827)
<b>Suspension strut</b>			
Type		Suspension strut with 5 spring preload settings, twin-tube, gas-filled shock absorber	



Technical Data		R 850 R	R 1100 R
<b>Front suspension</b>			
Type		BMW Telelever with external suspension strut	
<b>Telescopic fork</b>			
Front wheel caster in normal-load position (with rider weighing 85 kg (187.425 lb))	mm (in)	127 (5)	127 (5)
Steering lock angle	°	37	37
Total suspension travel	mm (in)	120 (4.7244)	120 (4.7244)
Fixed tube surface		Hard chrome plated	Hard chrome plated
Extl. dia. of fixed fork tubes	mm (in)	35,0 (1.3779)	35,0 (1.3779)
Maximum permissible runout of fixed fork tube	mm (in)	0,4 (0.01574)	0,4 (0.01574)
Telescopic fork oil – approved grades		BMW telescopic fork oil	BMW telescopic fork oil
Fill quantity in each fork leg	l (Imp. pints)	0.470 (0.827)	0.470 (0.827)
<b>Suspension strut</b>			
Type		Suspension strut with twin-tube gas-filled shock absorber	

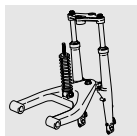

## Removing and installing telescopic fork

### Removing and installing telescopic fork without fork bridge

- Remove mudguard.
- Remove front wheel.
- **[ABS]** Detach sensor.
- Detach brake line retainer.
- **[R]** Heat steering damper mount at slider tube bridge to max. 120 °C, and take it of.

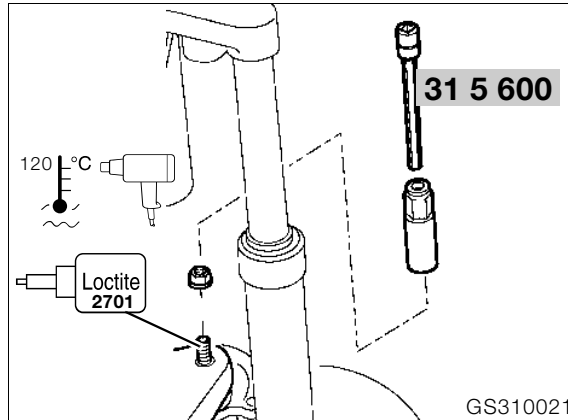

- Heat leading link mount at front to max. 120 °C and unscrew.
- **[RS]** Loosen fixed-tube clamp at upper fork bridge and pull telescopic fork out downwards.

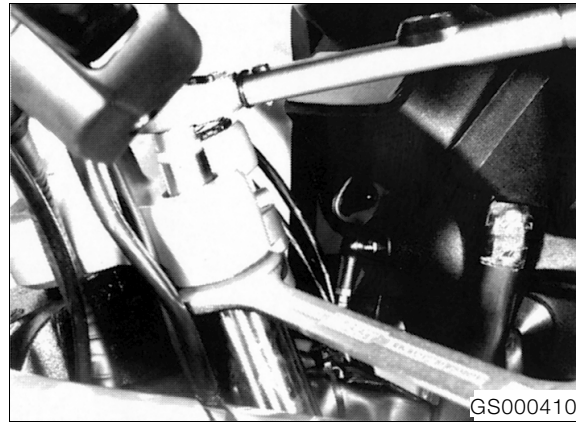

- **[R/RT]** Take off the handlebar.
- **[GS/R/RT]** Slacken off the threaded connection for the fixed tube at the upper fork bridge, holding the hexagon on the fixed tube to prevent it from turning; pull telescopic fork out downwards.
- Install in the reverse order of work.
- Tighten ball joint at leading arm with socket wrench insert and internal hexagon, **BMW No. 31 5 600**, on leading link.

#### **! Caution:**

To prevent grease from escaping and the ingress of dirt, ensure that sleeve is correctly located on ball joint.

- **[ABS]** Check sensor gap and adjust if necessary.

**ABS - Sensor gap:** ..... 0.50...0.55 mm  
..... (0.0197...0.0217 in)

#### **! Tightening torque:**

Ball joint at leading link:  
(clean thread + Loctite 2701)..... 130 Nm

Mount, fixed tube/fork bridge  
**[RS]** ..... 22 Nm  
Threaded connection, fixed tube/fork bridge  
(free from oil or grease) .....  
**[GS/R/RT]** ..... 45 Nm  
Handlebar to fork bridge  
**[R/RT]** ..... 21 Nm  
Steering damper at slider tube bridge mount  
(clean thread + Loctite 2701)  
**[R]** ..... 20 Nm  
Steering damper mount at slider tube bridge  
(clean thread + Loctite 2701)  
**[R]** ..... 9 Nm



## [RS] Removing and installing fork bridge

- Separate connecting plug for ignition/steering lock.
- Unscrew handlebar mount on fork bridge.

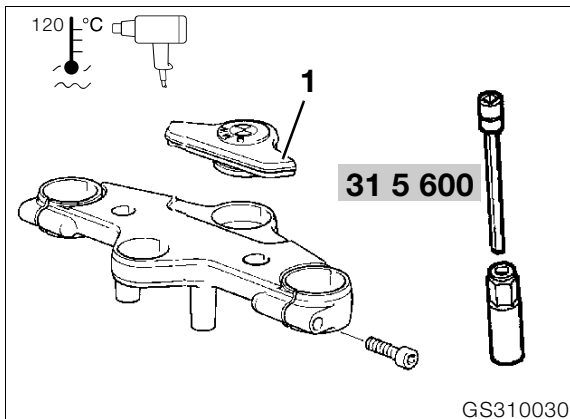

- Remove trim (1).
- Heat ball joint mount on fork bridge to max. 120 °C and unscrew using Allen key socket wrench insert, **BMW No. 31 5 600**.
- Unscrew fixed tube clamp mount at top of fork bridge.
- Remove fork bridge.
- Remove ignition/steering lock.
- Install in the reverse order of work.

**Projection of fixed tube beyond fork bridge:**  
 ..... 5 ± 0.5 mm (0.1969 ± 0.01969 in)

**Tightening torque:**  
 Mount, fixed tube/fork bridge ..... 22 Nm  
 Ball joint at fork bridge  
 (clean thread + Loctite 2701)..... 130 Nm

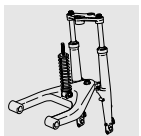

## [GS/R/RT] Removing and installing fork bridge

- Unscrew fuel tank and pull to the rear.
- Separate connecting plug for ignition/steering lock.
- Detach handlebar from fork bridge.

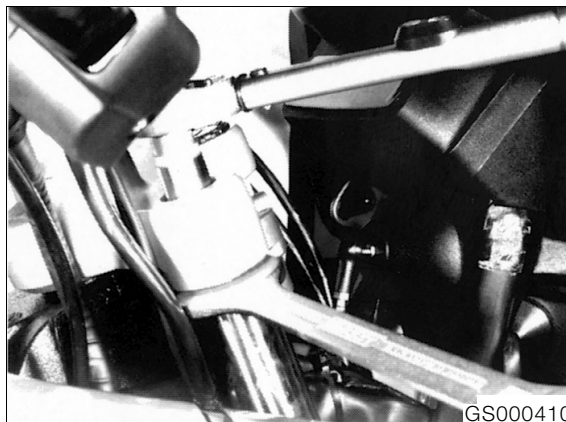

- Unfasten fixed tube screw connection at fork bridge, preventing movement by holding hexagon on fixed tube.
- Unfasten screw connection between fork bridge and frame.



### Note:

Screw pin is a press fit in ball thrust bearing; remove complete unit.

- **[R]** Scheinwerferhalterung nach vorne ziehen.
- Gabelbrücke abnehmen.
- Zündlenkschloß ausbauen.
- Einbau in umgekehrter Reihenfolge.



### Tightening torque:

Screw connection between fork bridge and frame  
 (clean thread + Loctite 243)..... 130 Nm  
 Threaded connection between fork bridge and fixed  
 tube (free from oil and grease)..... 45 Nm  
 Handlebar to fork bridge ..... 21 Nm

## Removing and installing pot-type joints

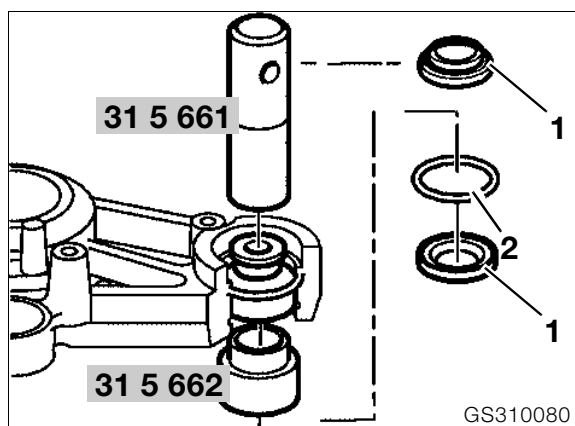

- Remove dust covers (1).
- Remove top snap ring (2).
- Press out pot-type joint using drift and bushing, **BMW No. 31 5 660**.

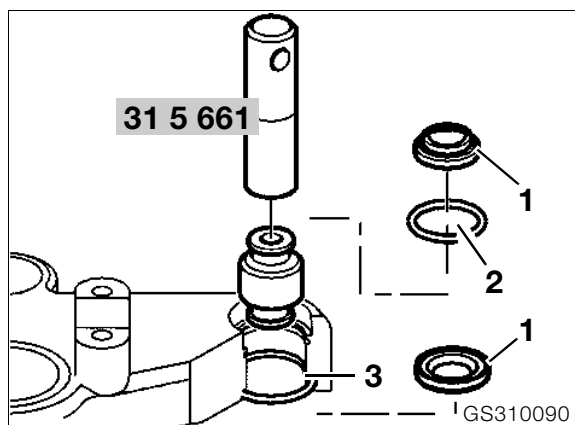

- Snap ring (3) is installed.
- Press in pot-type joint using drift, **BMW No. 31 5 661**.
- Install snap ring (2).
- Install dust covers (1).



## Removing and installing ball thrust bearing

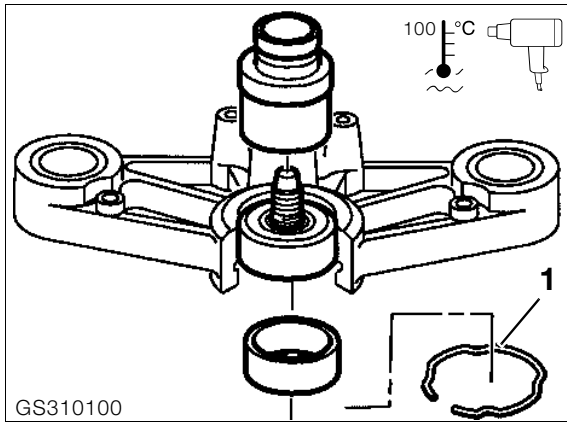

- Remove retaining ring (1).
- Heat fork bridge to 100 °C.
- Remove ball thrust bearing, if necessary striking lightly with a plastic-faced hammer.

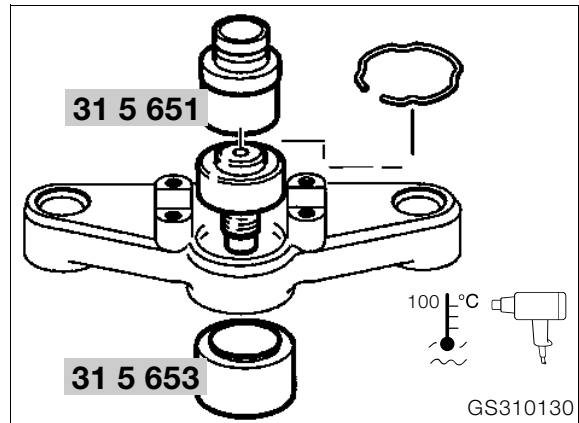

- Heat the fork bridge to 100 °C and press the ball thrust bearing in with pin, **BMW No. 31 5 651** and bushing, **BMW No. 31 5 653**.
- Install retaining ring.

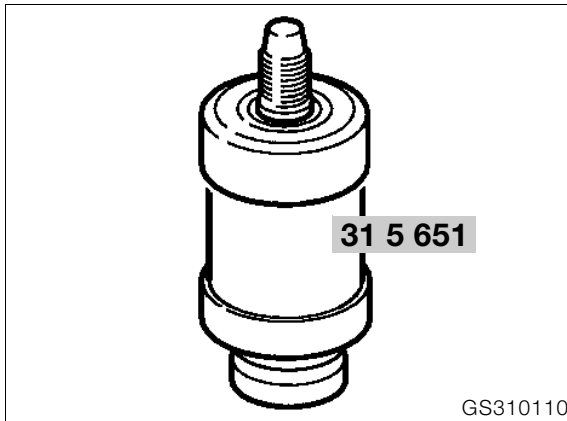

- Press out the threaded journal using a pin, **BMW No. 31 5 651**, as a support.

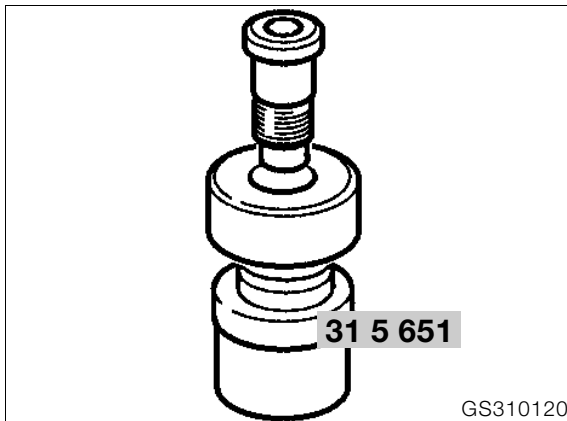

- Press the threaded journal into the ball thrust bearing using a pin, **BMW No. 31 5 651**, as a support.





## Removing and installing slider tube bridge

- Remove front mudguard.
- Heat ball joint mount at slider tube bridge to max. 120 °C and detach it.
- **[R]** Heat the steering damper mount at the slider tube bridge to max. 120 °C and detach it..

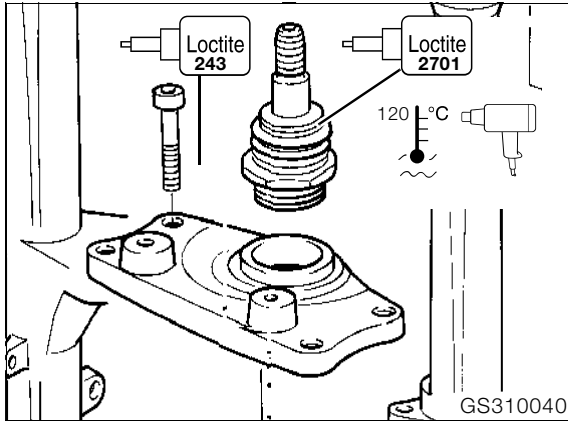

- **[RS/GS]** Detach the brake line distributor block.
- **[ABS]** Detach the sensor line from the slider tube bridge.
- Unscrew slider tube bridge.
- Install in the reverse order of work.
- Secure the ball joint to the leading link using socket wrench insert and Allen key, **BMW No. 31 5 600**.

### **Caution:**

Comply with assembly instructions for telescopic fork.

### **Tightening torque:**

Bridge to fork slider  
(clean thread + Loctite 243)..... 22 Nm  
Ball joint on control arm  
(clean thread + Loctite 2701)..... 130 Nm

### **Removing and installing ball joint**

- Mount the slider tube bridge in retaining fixture, **BMW No. 31 5 620**.
- Unscrew/tighten ball joint with 46 mm (1.811 in) socket wrench insert, **BMW No. 31 5 630**.

### **Tightening torque:**

Ball joint to fork slider bridge ..... 230 Nm

## [RS] Checking ball joint friction

## [GS/R/RT] Checking ball joint/ball thrust bearing friction

- Motorcycle must be supported on center stand with front wheel clear of the ground.
- Measure the breakaway torque to left and right from the central position of the handlebar with friction gauge, **BMW No. 00 2 57**.



### **Note:**

To determine the friction value, increase torque very slowly.

### **Friction value:**

Measure at room temperature (above 20 °C)

Nominal value: ..... 1.0...4.0 Nm



**Assembly specification for telescopic fork:**

**⚠ Caution:**

To ensure that the fork is installed without trapped stresses, observe the following instructions and the specified working sequence precisely.

- The front suspension strut is removed.

**⚠ Caution:**

Protect painted parts from scratching: apply adhesive masking tape if necessary.

- Bolt fork bridge to frame.

**🔧 Tightening torque:**

Fork bridge to ball joint  
(clean thread + Loctite 2701)  
**[RS]** ..... 130 Nm  
Threaded journal to frame  
(clean thread + Loctite 243)  
**[GS/R/RT]** ..... 130 Nm

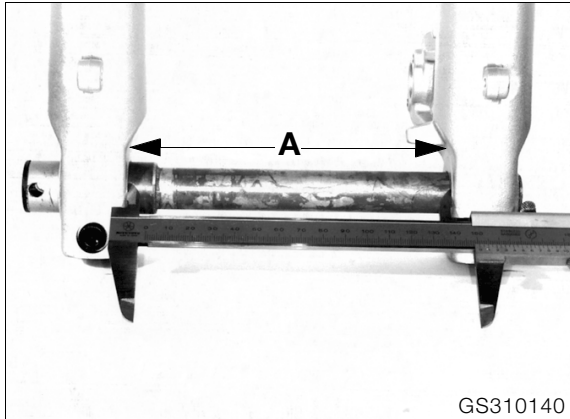

- Pre-assemble fork legs with quick-release axle/ adjust distance A.

**Distance A:**..... 165 ± 0.5 mm (6.496 ± 0.01969 in)

**🔧 Tightening torque:**

Quick-release axle clamps ..... 22 Nm

**📄 Note:**

If the quick-release axle was not removed, for instance when only the fork slider tube bridge was removed/installed, the above work stage is omitted.

- Secure slider tube bridge/do not tighten to specified torque at this point.
- Screw slider tube bridge to leading link.

**🔧 Tightening torque:**

Leading link at ball joint  
(clean thread + Loctite 2701)..... 130 Nm

- Using a strap or similar, pull fork towards frame until the fully retracted fixed tubes only need to be pulled out slightly to secure them to the fork bridge. Secure fixed tubes to the fork bridge.
- Secure fixed tubes to the fork bridge.

**🔧 Tightening torque:**

Clamp between fixed tubes and fork bridge  
**[RS]** ..... 22 Nm  
Screw connection between fixed tube and fork bridge (oil/grease free)  
**[GS/R/RT]**..... 45 Nm

- Tighten down slider tube bridge.

**🔧 Tightening torque:**

Bridge to fork slider (clean thread + Loctite 243)..... 22 Nm

- Check that the system moves freely by compressing and extending the suspension (but without the suspension strut) in the straight-ahead and left/right steering lock positions.
- Remove quick-release axle.

**⚠ Caution:**

When being reassembled, the quick-release axle must well aligned; it should be possible to install it by rotating it slightly.

- Install suspension strut.

**🔧 Tightening torque:**

Spring strut to frame ..... 47 Nm  
Spring strut to leading link  
**[RS]** (8.8 bolt)..... 43 Nm  
**[RS]** (10.9 bolt)..... 50 Nm  
**[GS/R/RT]** (10.9 bolt)..... 50 Nm

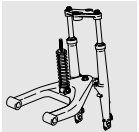

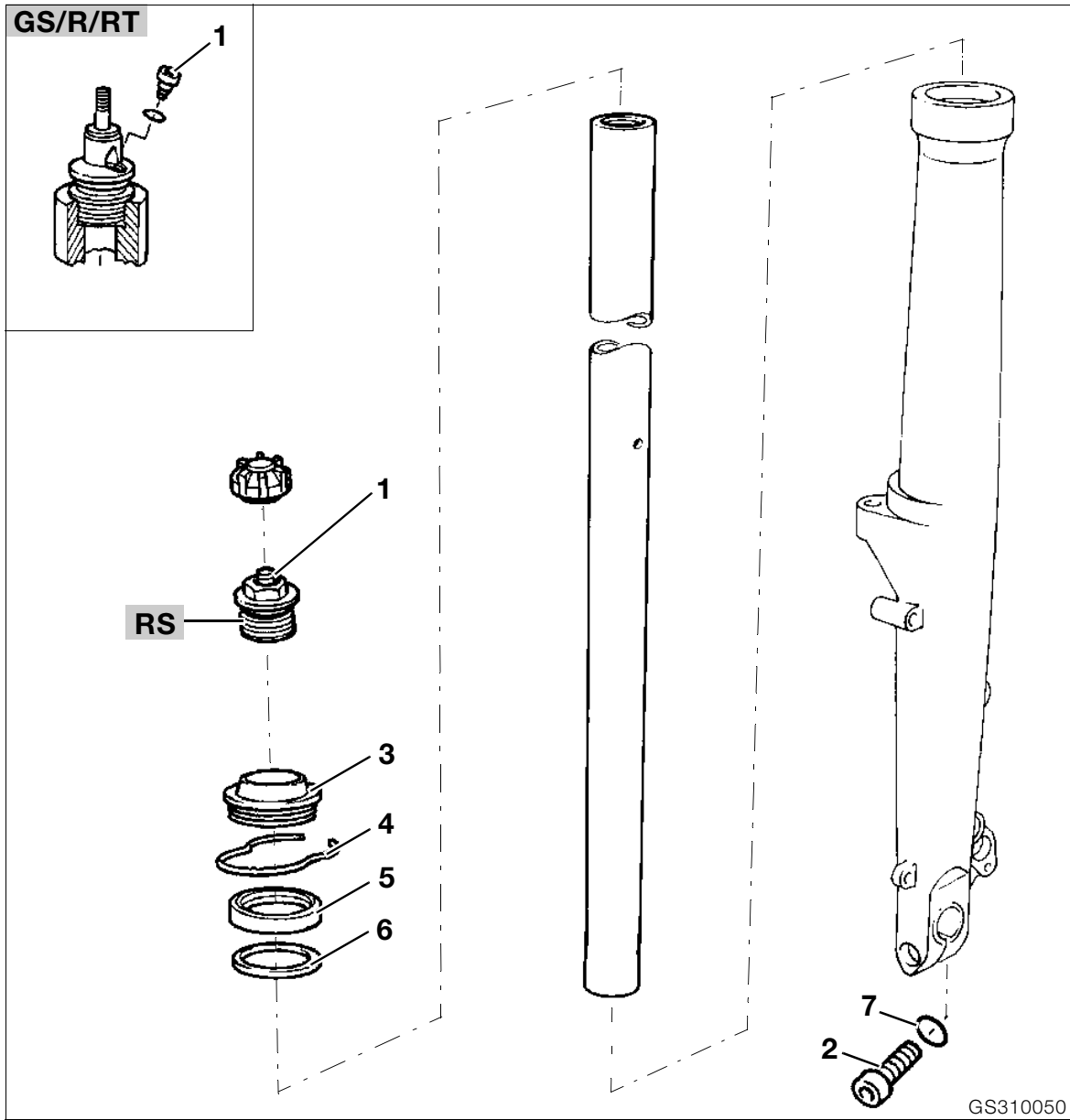

## Dismantling/reassembling telescopic fork

### Dismantling telescopic fork

- Remove bleed screw (1).
- Remove drain plug (2)/drain oil.
- Remove fixed tube.
- Remove dust cover (3)/retaining ring (4).
- Lever out shaft seal (5)



#### Caution:

Do not damage fork slider tube.

- Remove washer (6).



## Assembling telescopic fork

- Insert oil drain plug.



### Caution:

Install a new O-ring (7). Make sure the O-ring is correctly seated.

- Fill with oil.

### Fill quantity per fixed tube:

**[RS/GS/R/RT]** .....0.470 l (0.827 Imp. pints)

### Oil grade in telescopic fork:

.....BMW telescopic fork oil



### Note:

No oil changes required during services: unit is maintenance-free.

- Install fixed tube.
- Install washer (6).
- Oil the shaft seal slightly and push it on as far as possible (to stop on slider tube) by striking it lightly with drift, **BMW No. 31 5 610**, and reducing adapter, **BMW No. 31 5 613**.
- Install retaining ring and dust cover.
- Insert bleed screw (1).
- Bleed telescopic fork in no-load position.



### Tightening torque:

**[RS]** Threaded plug at fixed tube ..... 18 Nm

**[GS/R/RT]** Threaded plug at fixed tube

..... press-fit - do not remove!

## Measuring telescopic fork



### Caution:

After an accident, always examine the telescopic fork for cracks and signs of damage.

### Check slider tube bridge

- Check that the slider tube bridge is flat.



### Caution:

Renew slider tube bridge if distorted.

### Checking runout of fixed tube

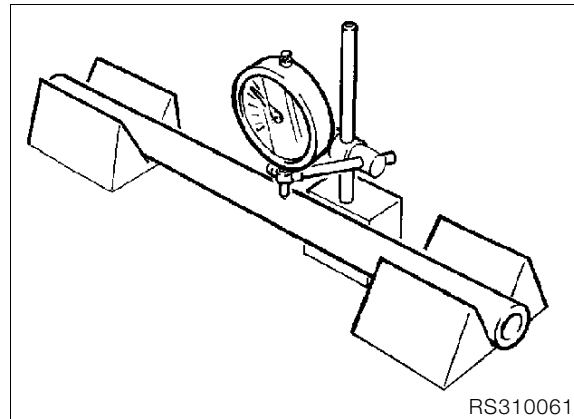

- Place both ends of fixed tube in V-blocks.
- Rotate fixed tube slowly and check with dial gauge while doing so.



### Caution:

Do not straighten distorted fixed tubes: always renew them.

**Permissible runout:** ..... 0.4 mm (0.0157 in)

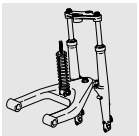

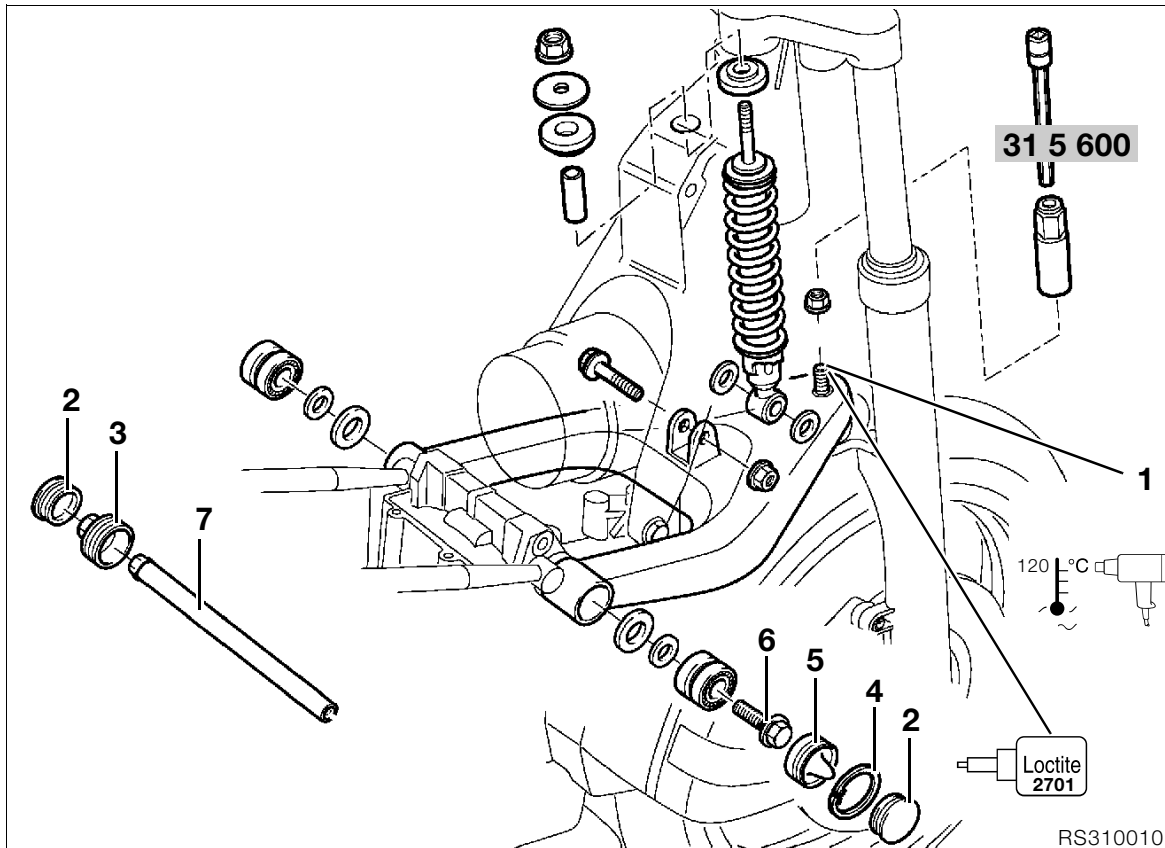

## Removing and installing leading link

- **[RT]** Remove side sections of fairing.
- **[R]** Detach steering damper mount at leading link.
- Unscrew bottom of spring strut.
- Heat ball joint mount (1) at leading link to max. 120 °C and detach it.
- Remove covers (2) from leading link pivots.
- Remove left screw cap (3).
- Remove right retaining ring (4) and retaining cap (5).
- Take out right screw (6) and remove shaft (7) by pulling to the left.
- Pull telescopic fork forwards and carefully remove leading link by pulling forwards.

### ⚠ Caution:

Protect painted parts from scratching: apply adhesive masking tape if necessary

- Install in the reverse order of work.
- Apply a light coating of grease to the axle before installing.
- Using socket wrench insert and Allen key, **BMW No. 31 5 600**, tighten the ball joint at the leading link.
- **[RS]** Coat the lower suspension strut mount with **Never Seez**.

### 📄 Note:

Only applies to plain bearings

### 🔧 Tightening torque:

Right control arm on engine .....	73 Nm
Left screw cap (coat thread lightly with Never Seez).....	42 Nm
Leading link to ball joint (clean thread + Loctite 2701).....	130 Nm
Spring strut to leading link <b>[RS]</b> (8.8 bolt).....	43 Nm
<b>[RS]</b> (10.9 bolt).....	50 Nm
<b>[GS/R/RT]</b> (10.9 bolt).....	50 Nm
Steering damper mount to leading link <b>[R]</b> .....	20 Nm

## Dismantling/reassembling leading link

- Press bearing out/in using suitable tool.

### ⚠ Caution:

Always install bearing by applying pressure to outer race.



## Removing and installing front suspension strut

- **[RS]** Coat lower suspension strut pivot with **Never Seize**.



### Note:

Only applies to plain bearings.



### Tightening torque:

Spring strut to frame .....	47 Nm
Spring strut to leading link	
<b>[RS]</b> (8.8 bolt) .....	43 Nm
<b>[RS]</b> (10.9 bolt) .....	50 Nm
<b>[GS/R/RT]</b> (10.9 bolt) .....	50 Nm

## [R] Removing and installing steering damper

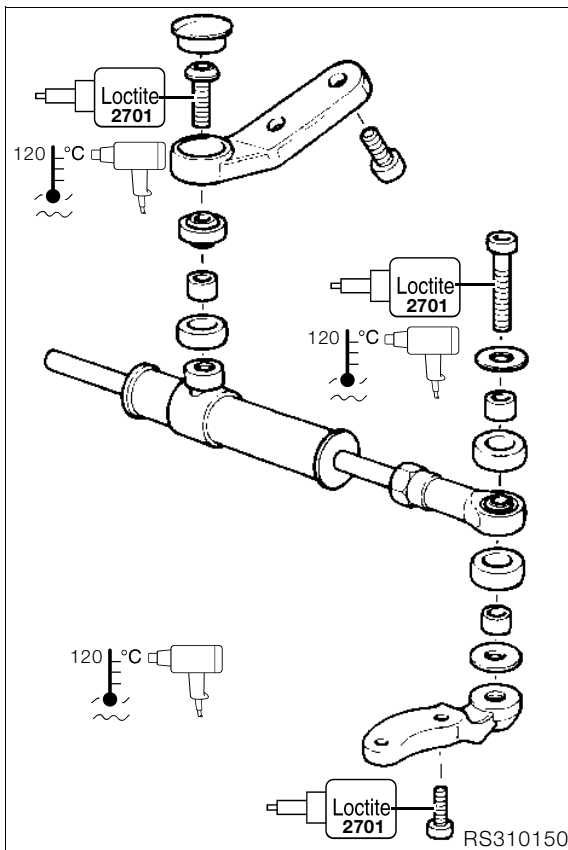

- Heat steering damper mount to max. 120 °C and detach it.

## Removing and installing ball head

- Unscrew ball head.
- When installing, locknut must make contact with piston rod/end of thread; lock ball head against nut.



### Caution:

Do not dismantle the steering damper.



### Tightening torque:

Steering damper at slider tube bridge mount (clean thread + Loctite 2701).....	20 Nm
Steering damper mount at slider tube bridge (clean thread + Loctite 2701).....	9 Nm
Steering damper at leading link mount (clean thread + Loctite 2701).....	20 Nm
Steering damper mount to leading link.....	20 Nm
Joint head to locknut.....	20 Nm

## Checking the steering damper

- Freedom from play at ball head.
- Freedom from play at piston rod.
- Turn the steering to the left and try to rock the front end of the housing radially to and fro.

# 32 Steering

Contents	Page
<b>Technical Data</b> .....	3
<b>Removing and installing left handlebar fitting</b> .....	7
With heated handlebar grips .....	7
Without heated handlebar grips .....	7
<b>Removing and installing right handlebar fitting</b> .....	8
With heated handlebar grips .....	8
Without heated handlebar grips .....	8
<b>[RS] Removing and installing handlebar</b> .....	9
<b>[GS/R/RT] Removing and installing handlebar</b> .....	10
<b>Removing and installing wire cable distributor block</b> .....	11
<b>Removing and installing throttle cable</b> .....	12
With wire cable distribution block .....	13
<b>Removing and installing cold-start cable</b> .....	14
With wire cable distribution block .....	14
<b>Removing and installing clutch cable</b> .....	15

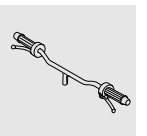

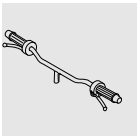



Technical Data		R 1100 RS
Steering lock angle	°	2 x 32
Steering head tube dia.	mm (in)	22 (0.866)
Handlebar width with weights	mm (in)	738 (29.055)

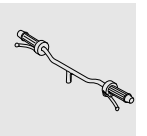

Technical Data		R 1100 RT
Steering lock angle	°	2 x 34
Steering head tube dia.	mm (in)	22 (0.866)
Handlebar width with weights	mm (in)	775 (30.512)

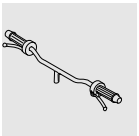

Technical Data	R 850 GS	R 1100 GS
Steering lock angle °	2 x 42	2 x 42
Steering head tube dia. mm (in)	22 (0.866)	22 (0.866)
Handlebar width with weights mm (in)	890 (35.0397)	890 (35.0397)

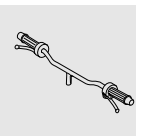

<b>Technical Data</b>		<b>R 850 R</b>	<b>R 1100 R</b>
Steering lock angle	°	2 x 37	2 x 37
Steering head tube dia.	mm (in)	22 (0.866)	22 (0.866)
Handlebar width with weights	mm (in)	780 (30.7087)	780 (30.7087)

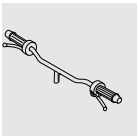

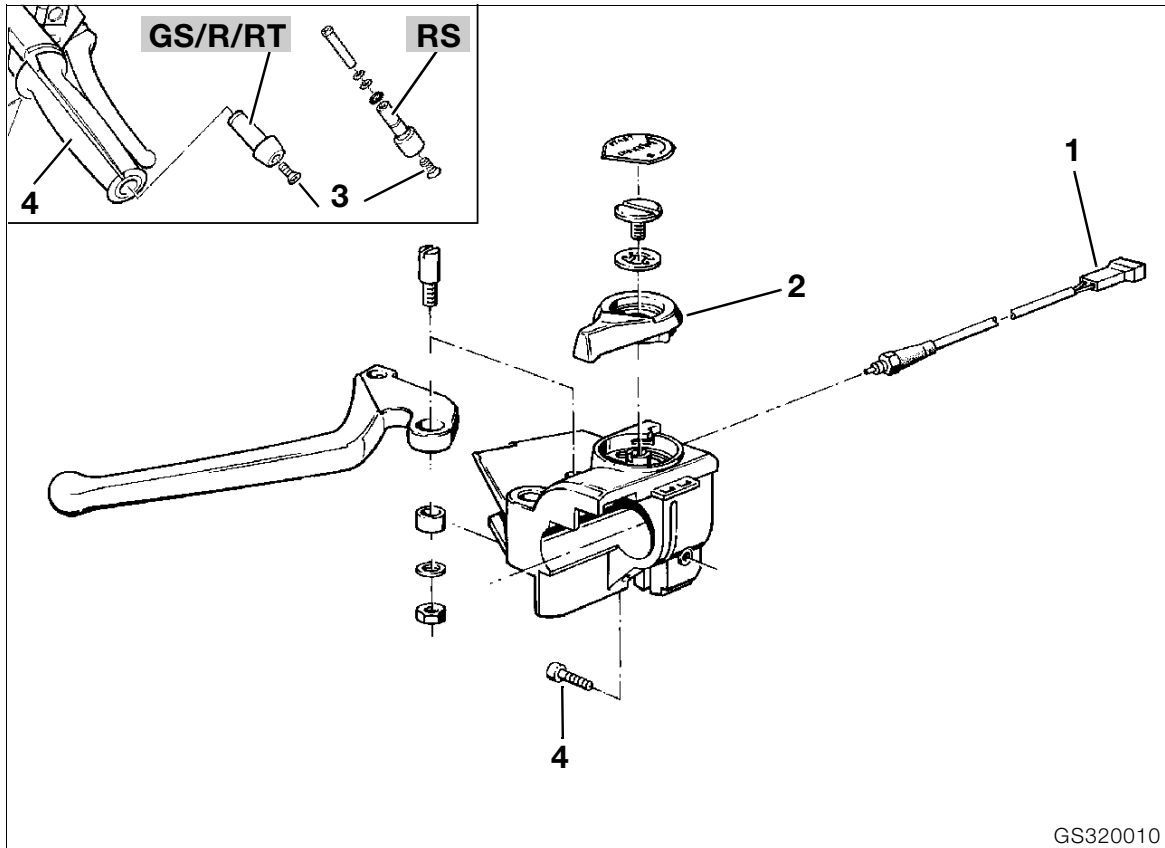

## Removing and installing left handlebar fitting

- **[RS]** Remove left side fairing.
- **[GS/R]** Detach fuel tank and pull to the rear.
- **[RT]** Remove upper section of fairing.
- Separate plug connection (1) at clutch switch.
- Disconnect cable for raised idle speed (choke) at actuating lever (2).
- Disconnect clutch cable from release lever, then from handlebar lever.
- Unfasten screw (3) and pull out handlebar weight.
- Remove combination switch.

### With heated handlebar grips

- Fold back rubber grip at handlebar fitting end.
- Unfasten retaining screws for heated handlebar grip.
- Separate connector to heated handlebar grip.
- Unfasten cable shoes at connector.
- Pull lead through handlebar.

### Without heated handlebar grips

- Cut through rubber grip and pull it off.
- Loosen clamp screw (4) on handlebar fitting.
- Remove fitting from handlebar.
- Install in the reverse order of work.
- Align slot of handlebar fitting (arrow) with punch-mark on handlebar.
- Secure handlebar grip with **Loctite 638 adhe-sive and surface activator**.
- Adjust clutch cable and lubricate pivot with **Shell Retinax A**.
- ➡ See Group 00
- Check/adjust raised idle speed (choke) setting.
- ➡ See Group 00

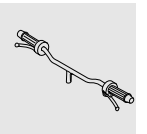

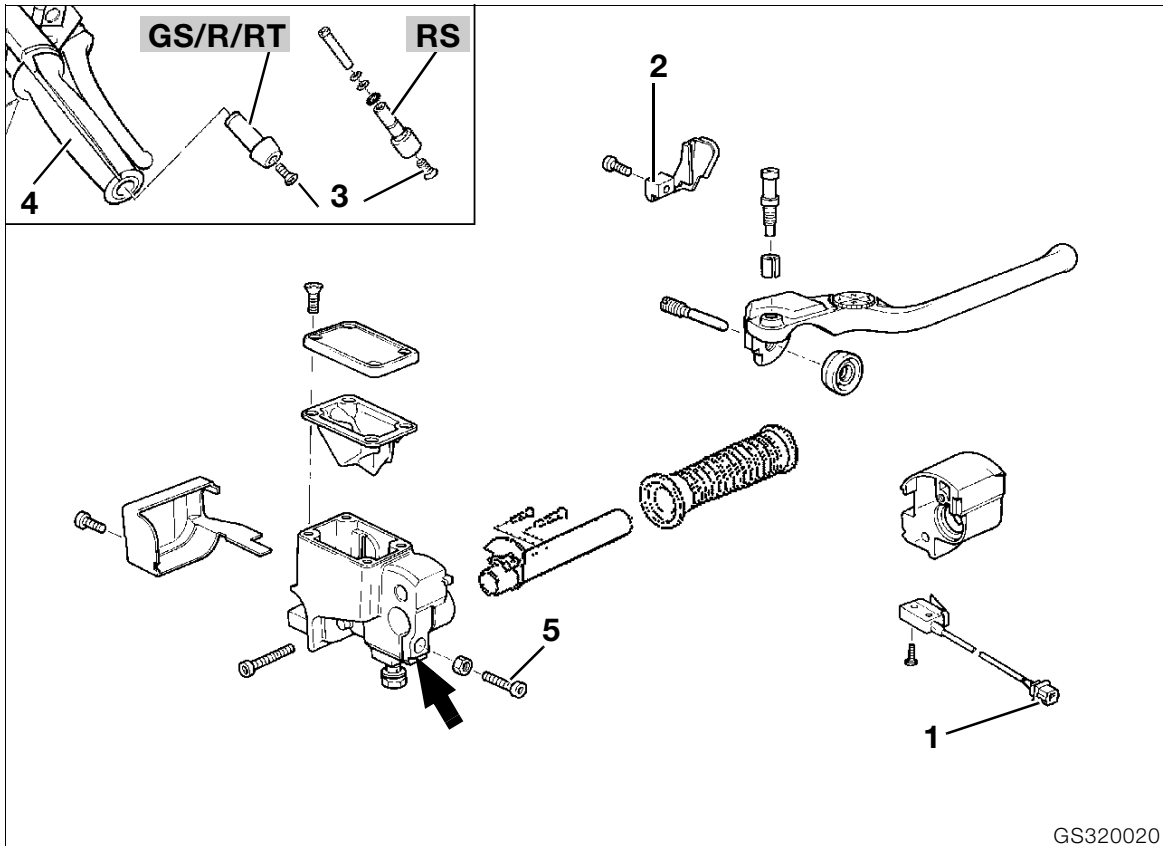

## Removing and installing right handlebar fitting

- **[RS]** Remove left side trim.
- **[GS/R]** Detach fuel tank and pull it to the rear.
- **[RT]** Remove upper section of fairing.
- Separate connector (1) at brake light switch.
- Detach brake line and seal off.

### ⚠ Caution:

Do not allow brake fluid to come into contact with painted parts of the motorcycle, because brake fluid destroys paint.

- Remove combination switch.
- Unfasten throttle cable cover (2) and disconnect throttle cable.
- Unfasten screw (3) and pull out handlebar weight.

### With heated handlebar grips

- Fold back rubber grip at handlebar fitting end.
- Unfasten retaining screws for heated handlebar grip.
- Separate connector to heated handlebar grip.
- Unfasten cable shoes at connector.
- Pull lead through handlebar.

### Without heated handlebar grips

- Cut open rubber grip (4) and pull off.
- Unfasten clamp screw (5) from fitting housing.
- Remove handlebar fitting.
- Install in the reverse order of work.
- Align slot of handlebar fitting (arrow) with punch-mark on handlebar.
- Secure rubber handlebar grip with **Loctite 638 adhesive and surface activator**.

### ⚠ Caution:

Top up brake fluid, bleed brake system.

**- Adjustable handlebar -** In the center position the brake hose fitting at the master brake cylinder must have sufficient clearance (app. 5 ... 10 mm (0.1969...0.3937in)) from the center section of the handlebar. If necessary, unfasten the wiring harness.

### ⚠ Tightening torque:

Brake hose to fitting ..... 7 Nm

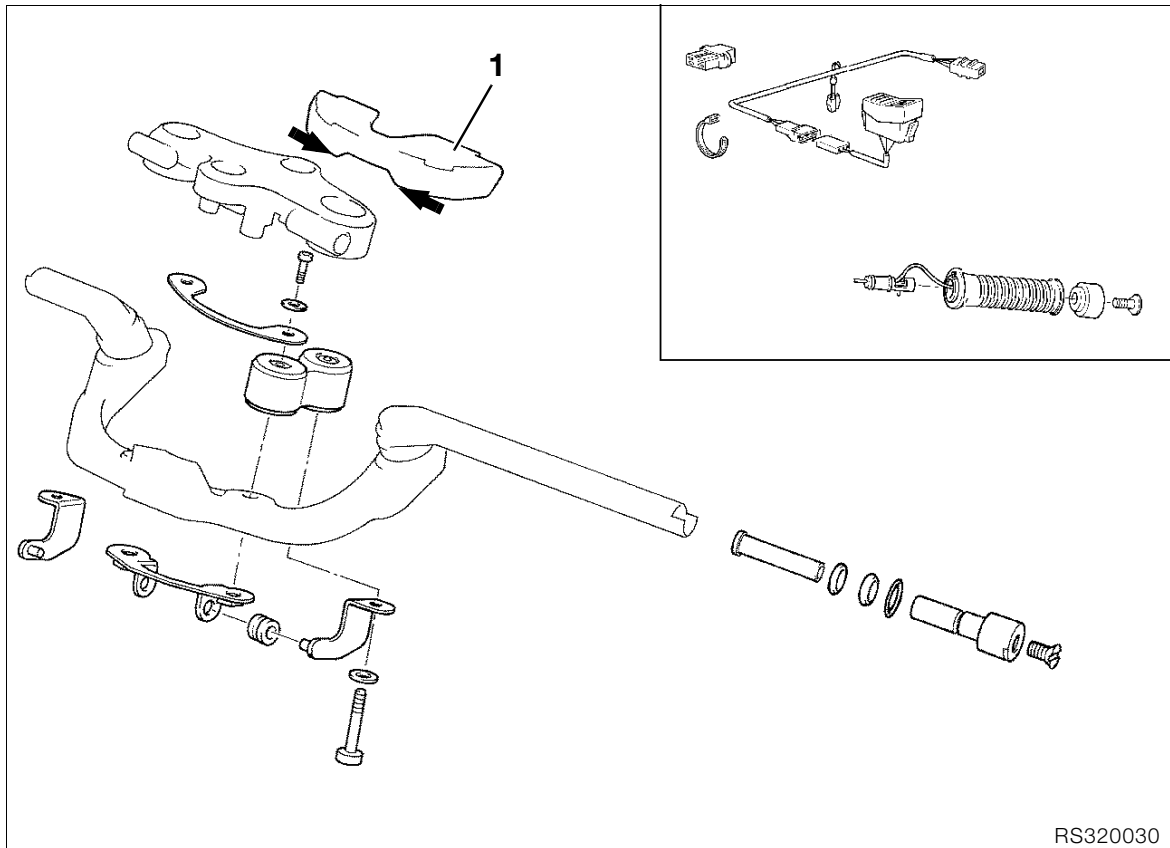

## [RS] Removing and installing handlebar

- Remove left/right handlebar fittings.
- Remove trim (1) from fork bridge (press hooks in direction of arrow).
- Remove handlebar.
- Install in the reverse order of work.



### Caution:

Ensure that brake hoses are correctly located.



### Tightening torquet:

Handlebar at rubber mount .....	40 Nm
Rubber mount at fork bridge .....	40 Nm
Handlebar weight to fixed handlebar .....	20 Nm
Handlebar weight to adjustable handlebar (clean thread + Loctite 2701).....	7 Nm

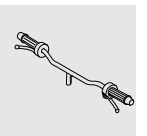

**GS**

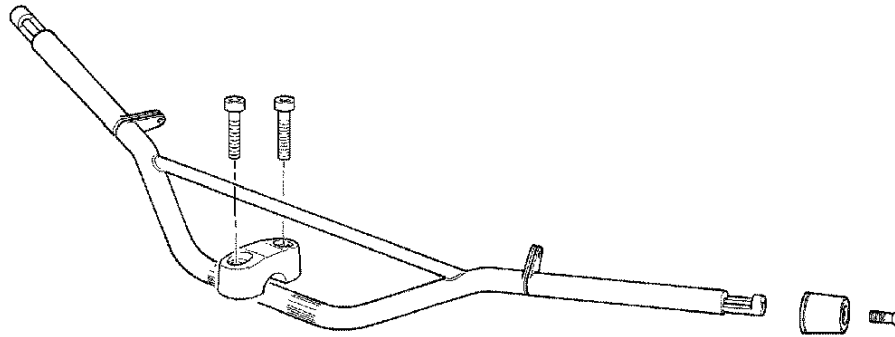

**R/RT**

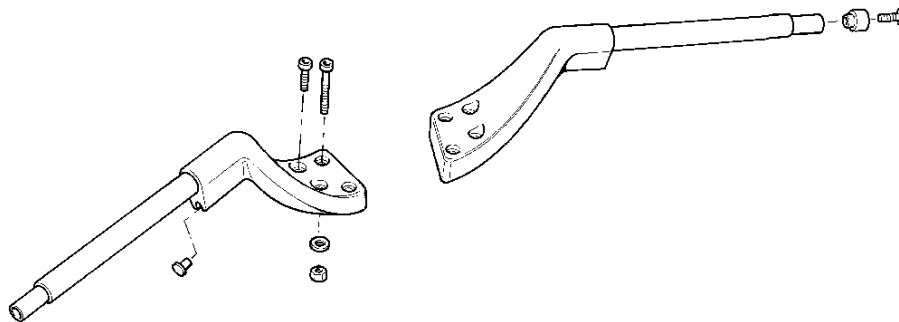

GS320030

### [GS/R/RT] Removing and installing handlebar

- Remove left/right handlebar fittings.
- Remove handlebar.
- Install in the reverse order of work.



**Caution:**

Make sure that brake hoses are correctly routed.  
**[GS]** Align punch mark on handlebar with gap between clamp blocks.



**Tightening torque::**

Clamp to fork bridge	
<b>[GS]</b> .....	21 Nm
Handlebar to fork bridge	
<b>[R/RT]</b> .....	21 Nm
Weight to handlebar .....	20 Nm

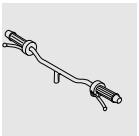



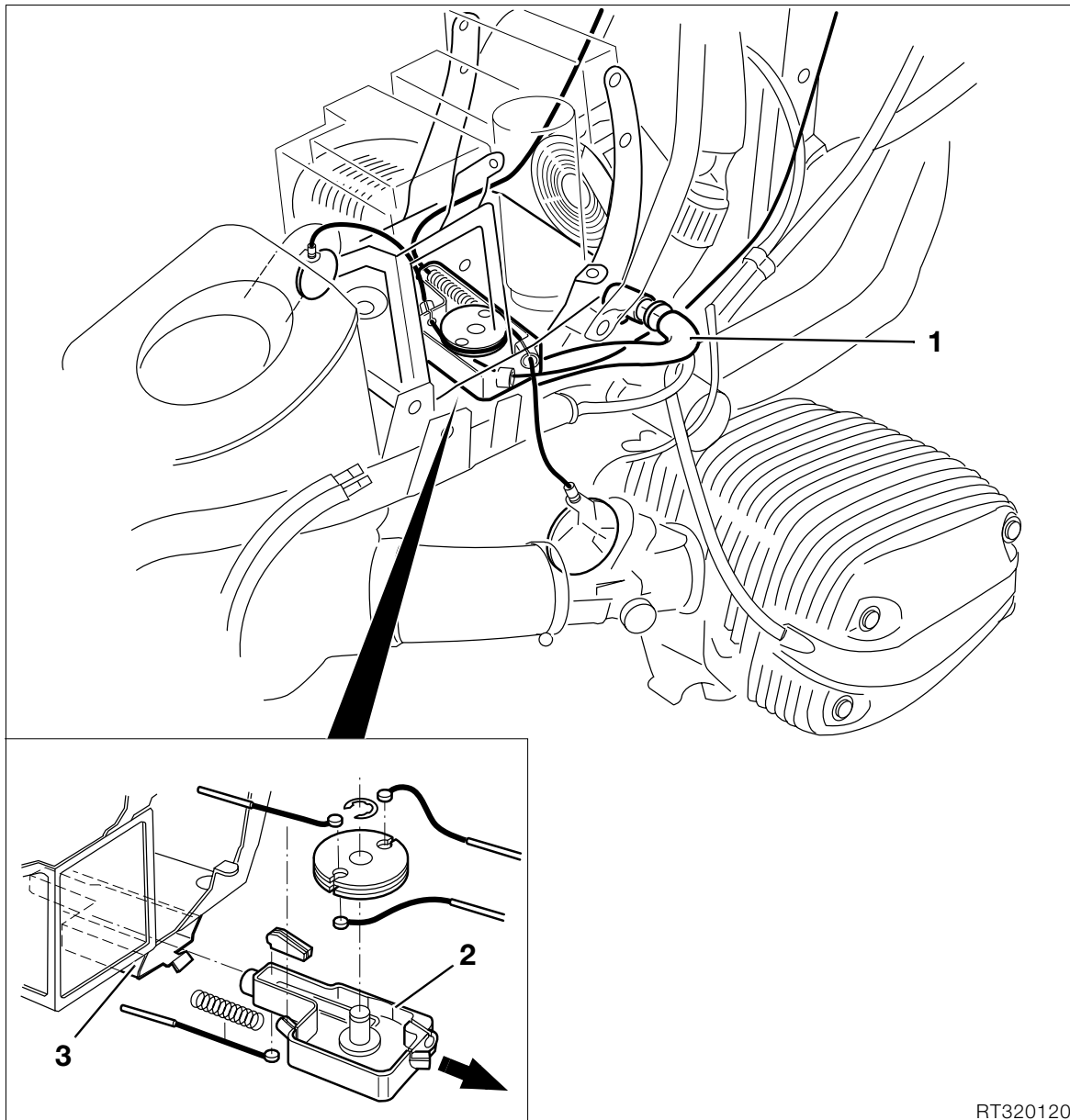

RT320120

## Removing and installing wire cable distributor block

- **[RS/RT]** Remove side fairings.
  - Unscrew fuel tank and pull to the rear.
  - Remove cold-start lever (increased idle speed)/ disconnect the wire cable.
  - Remove the cable cover at the throttle operating fitting.
  - Detach the wire cables at the left and right throttle stub pipes.
  - Release the cable straps.
  - Detach the engine breather pipe (1) from the engine.
  - Pull the wire cable distributor block (2) out of holder (3) in the direction of the arrow.
  - Install in the reverse order of work.
  - Adjust the wire cables.
- ➡ See Group 00

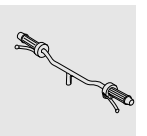

## Removing and installing throttle cable

- [RS] Remove left side fairing.
- [GS/RT] Detach fuel tank and pull it to the rear.

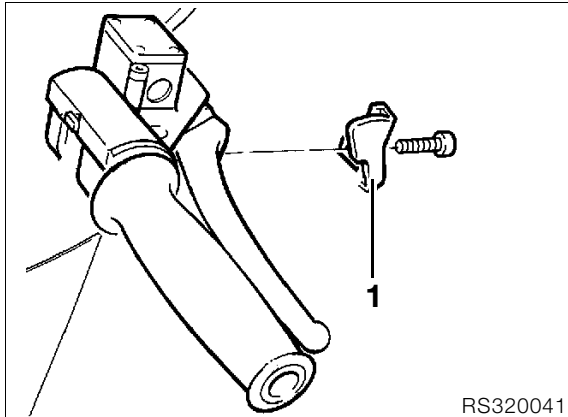

- Remove cable cover (1) from handlebar fitting and disconnect cable.

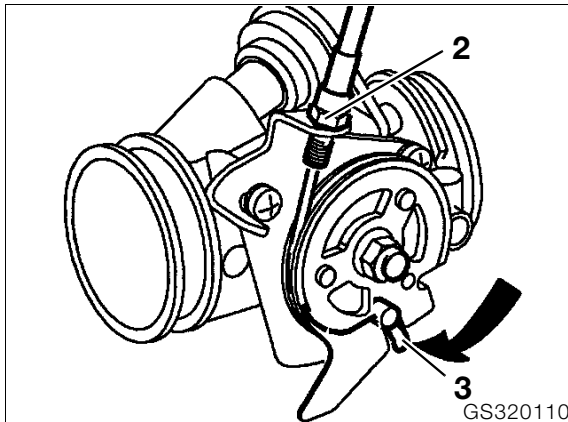

- Unfasten cable adjusting screw (2) on the right throttle body.
- Press in retaining spring (3) and disconnect cable.

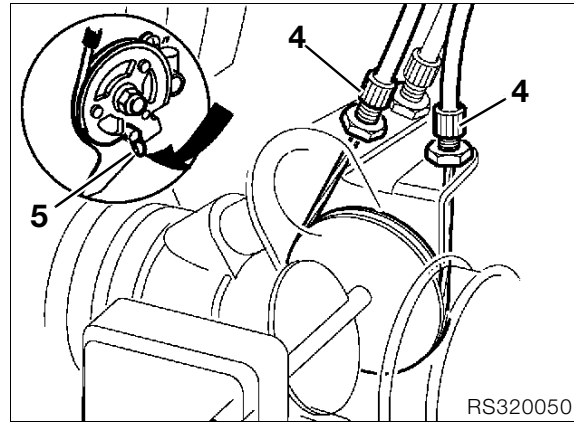

- Unfasten both cable adjusting screws (4) on left throttle body
- Press in retaining spring (5) and disconnect cable
- Install in the reverse order of work.

**⚠ Caution:**  
Install wire cable without kinking.

- Adjust wire cable.  
➡ See Group 00

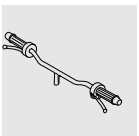

### With wire cable distribution block

- Remove cable cover (1) at fitting/disconnect the cable.
- Remove the choke lever/disconnect the cable.
- Remove the wire cable adjusting screws (2) at the right and left throttle stub pipes.
- Press in retaining spring (3) and disconnect the cables.

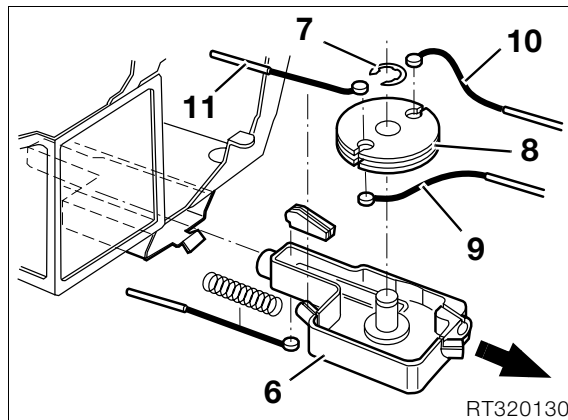

- Pull out the cable distribution block (6) in the direction of the arrow.
  - Release the keeper (7) and remove the distributing disk (8).
  - Disconnect cables (9), (10) and (11).
  - Install in the reverse order of work.
  - Adjust the wire cables.
- ➡ See Group 00

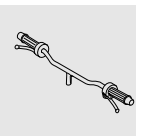

## Removing and installing cold-start cable

- [RS/RT] Remove the left fairing.
- [GS] Detach the fuel tank and pull it to the rear.

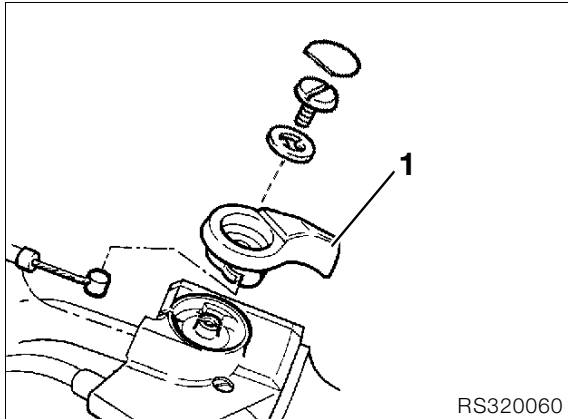

- Remove actuating lever (1)/disconnect cable

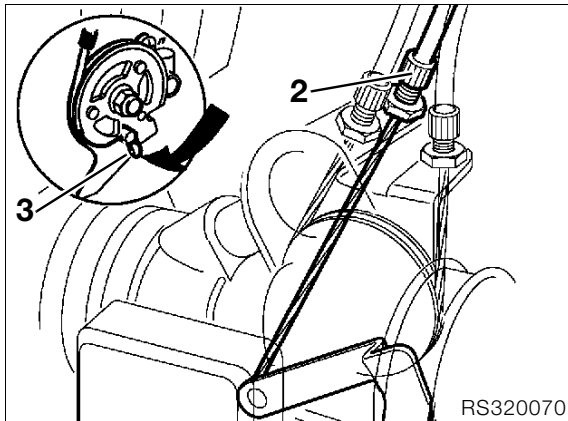

- Slacken off cable adjustment screw (2) on left throttle body
- Press in retaining spring (3) and disconnect cable.
- Install in the reverse order of work..



### Caution:

Install wire cable without kinking.

- Adjust wire cable.
- ➡ See Group 00

## With wire cable distribution block

- Remove cable cover at throttle fitting/disconnect the cable.
- Remove actuating lever (1)/disconnect cable.
- Remove the cable adjusting screws at the right and left throttle stub pipes.
- Press in the retaining spring and remove the cable

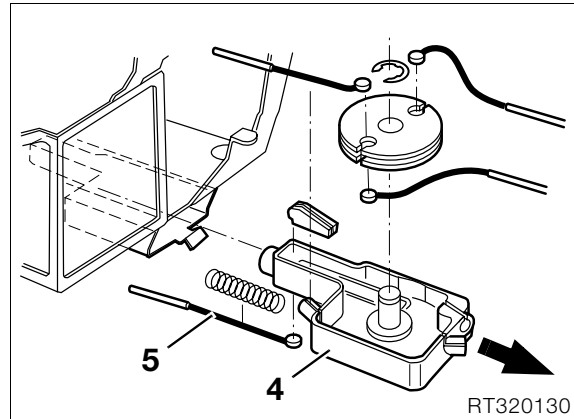

- Remove the wire cable distribution block (4) in the direction of the arrow.
- Detach cable (5).
- Install in the reverse order of work.
- Adjust wire cable
- ➡ See Group 00

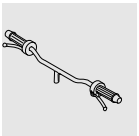

## Removing and installing clutch cable

- Remove right side trim.
- **[RT]** Detach fuel tank and pull it to the rear.

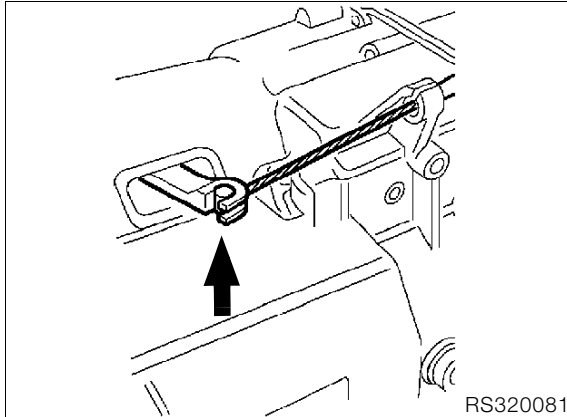

- Disconnect clutch cable from release lever/gearbox.

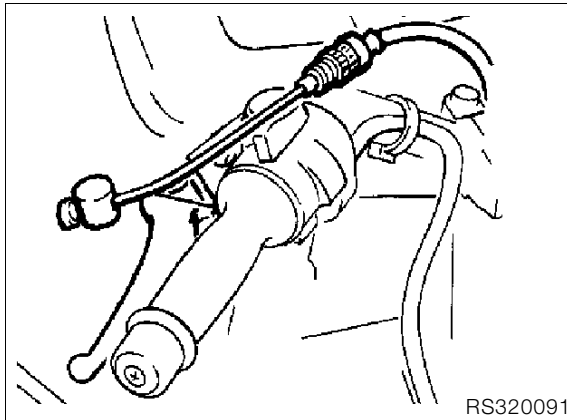

- Disconnect clutch cable from handlebar lever.
- Install in the reverse order of work.



### Caution:

Install wire cable without kinking.

- Adjust wire cable.
- ⇒ See Group 00

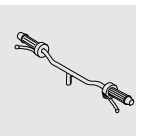

# 33 Rear wheel drive

<b>Contents</b>	Page
<b>Technical Data</b> .....	3
<b>Rear wheel drive-sectioned drawing</b> .....	7
<b>Removing, dismantling, reassembling and installing rear wheel drive</b> .....	9
Removing rear wheel drive .....	9
Removing input bevel pinion .....	9
Disassembling input bevel pinion .....	11
Removing needle roller bearing for input bevel pinion .....	12
Installing needle roller bearing for input bevel pinion .....	12
Assembling input bevel pinion .....	13
Installing input bevel pinion .....	14
Removing and installing taper roller bearing in rear wheel drive .....	15
Removing crown wheel .....	16
Installing crown wheel .....	17
Checking/adjusting backlash .....	18
Checking tooth contact pattern .....	19
Shimming housing cover .....	20
Installing housing cover .....	20
Installing splined element .....	20
Installing rear wheel drive .....	21
<b>Removing, dismantling, reassembling and installing rear swinging arm</b> ....	23
Removing rear swinging arm .....	23
Removing and installing taper roller bearing .....	23
Removing and installing flexible gaiter .....	24
Removing drive shaft .....	24
Checking universal joint for wear .....	24
Installing drive shaft .....	24
Installing rear swinging arm .....	25
<b>Removing and installing suspension strut</b> .....	26

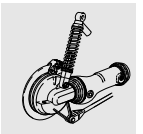

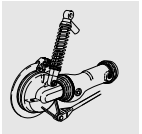

Technical Data		R 1100 RS
<b>Rear wheel drive</b>		
Gear tooth pattern	Klingelnberg-Palloid spiral bevel	
Gear ratios	Number of teeth	up to 1993 model year 3.09 : 1 34 : 11
	Number of teeth	from 1994 model year on 2.81 : 1 31 : 11
Backlash	mm (in)	0.07...0.16 (0.00276...0.0063)
Taper roller bearing preload	mm (in)	0.05...0.1 (0.00197...0.03937)
Oil grades	Brand-name hypoid gear oil, SAE 90 GL 5	
Filling capacity	l(Imp. pints)	Initial filling 0.25 (0.44)
	l(Imp. pints)	Oil changes 0.23 (0.405)
<b>Drive shaft</b>		
Layout	Two-piece drive shaft with integral torsional vibration damper enclosed in single swinging arm (BMW PARALEVER), universal joints at both ends, sliding joint at rear wheel drive end.	
<b>Swinging arm</b>		
Swinging arm length	mm (in)	355 (13.976)
<b>Rear suspension</b>		
Suspension strut	Suspension strut with single-tube, gas-filled shock absorber, continuously variable rebound-stage damping, seven spring preload settings.	
Suspension travel	mm (in)	135 (5.315)

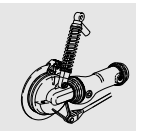



Technical Data		R 1100 RT
<b>Rear wheel drive</b>		
Gear tooth pattern	Klingelnberg-Paloid spiral bevel	
Gear ratios		2.91 : 1
Number of teeth		32 : 11
Number of teeth		
Backlash	mm (in)	0.07...0.16 (0.00276...0.0063)
Taper roller bearing preload	mm (in)	0.05...0.1 (0.00197...0.03937)
Oil grades	Brand-name hypoid gear oil, SAE 90 GL 5	
Filling capacity		Initial filling
I (Imp. pints)		0.25 (0.44)
I (Imp. pints)		Oil changes
		0.23 (0.405)
<b>Drive shaft</b>		
Layout	Two-piece drive shaft with integral torsional vibration damper enclosed in single swinging arm (BMW PARALEVER), universal joints at both ends, sliding joint at rear wheel drive end.	
<b>Swinging arm</b>		
Swinging arm length	mm (in)	355 (13.976)
<b>Rear suspension</b>		
Suspension strut		Suspension strut with single-tube gas-filled shock absorber, continuously variable rebound-stage damping and continuous hydraulic spring preload.
Suspension travel	mm (in)	135 (5.315)

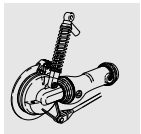

Technical Data	R 850 GS	R 1100 GS
<b>Rear wheel drive</b>		
Gear tooth pattern	Klingelnberg-Paloid spiral bevel	
Gear ratios	3.36 : 1	3.00 : 1
Number of teeth	37 : 11	33 : 11
Backlash mm (in)	0.07...0.16 (0.00276...0.0063)	0.07...0.16 (0.00276...0.0063)
Taper roller bearing preload mm (in)	0.05...0.1 (0.00197...0.03937)	0.05...0.1 (0.00197...0.03937)
Oil grades	Brand-name hypoid gear oil, SAE 90 GL 5	
Filling capacity	Initial filling	Initial filling
l (Imp. pints)	0.25 (0.44)	0.25 (0.44)
	Oil changes	Oil changes
l (Imp. pints)	0.23 (0.405)	0.23 (0.405)
<b>Drive shaft</b>		
Layout	Two-piece drive shaft with integral torsional vibration damper enclosed in single swinging arm (BMW PARALEVER), universal joints at both ends, sliding joint at rear wheel drive end.	
<b>Swinging arm</b>		
Swinging arm length mm (in)	355 (13.976)	355 (13.976)
<b>Rear suspension</b>		
Suspension strut	Suspension strut with single-tube gas-filled shock absorber, continuously variable rebound-stage damping and continuous hydraulic spring preload.	Suspension strut with single-tube gas-filled shock absorber, continuously variable rebound-stage damping and continuous hydraulic spring preload.
Suspension travel mm (in)	200 (7.874)	200 (7.874)

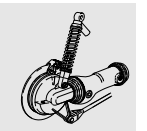

Technical Data	R 850 R	R 1100 R
<b>Rear wheel drive</b>		
Gear tooth pattern	Klingelnberg-Paloid spiral bevel	
Gear ratios	3.36 : 1	3.00 : 1
Number of teeth	37 : 11	33 : 11
Backlash mm (in)	0.07...0.16 (0.00276...0.0063)	0.07...0.16 (0.00276...0.0063)
Taper roller bearing preload mm (in)	0.05...0.1 (0.00197...0.03937)	0.05...0.1 (0.00197...0.03937)
Oil grades	Brand-name hypoid gear oil, SAE 90 GL 5	
Filling capacity	Initial filling	Initial filling
I (Imp. pints)	0.25 (0.44)	0.25 (0.44)
	Oil changes	Oil changes
I (Imp. pints)	0.23 (0.405)	0.23 (0.405)
<b>Drive shaft</b>		
Layout	Two-piece drive shaft with integral torsional vibration damper enclosed in single swinging arm (BMW PARALEVER), universal joints at both ends, sliding joint at rear wheel drive end.	
<b>Swinging arm</b>		
Swinging arm length mm (in)	355 (13.976)	355 (13.976)
<b>Rear suspension</b>		
Suspension strut	Suspension strut with single-tube gas-filled shock absorber, continuously variable rebound-stage damping and seven-position adjustable spring preload.	Suspension strut with single-tube gas-filled shock absorber, continuously variable rebound-stage damping and seven-position adjustable spring preload.
Suspension travel mm (in)	135 (5.315)	135 (5.315)

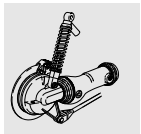

# Rear wheel drive-sectioned drawing

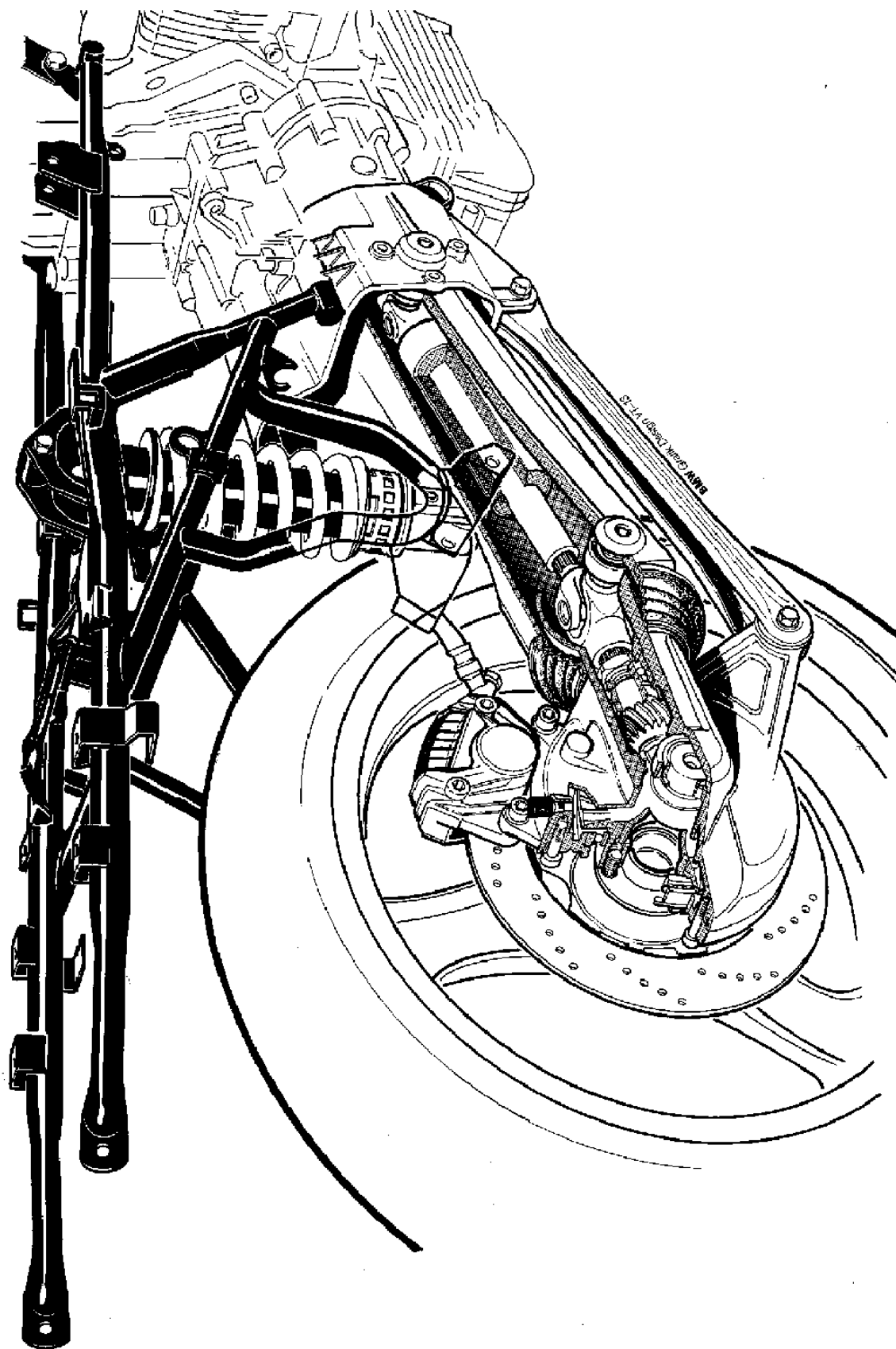

RS339011

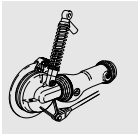

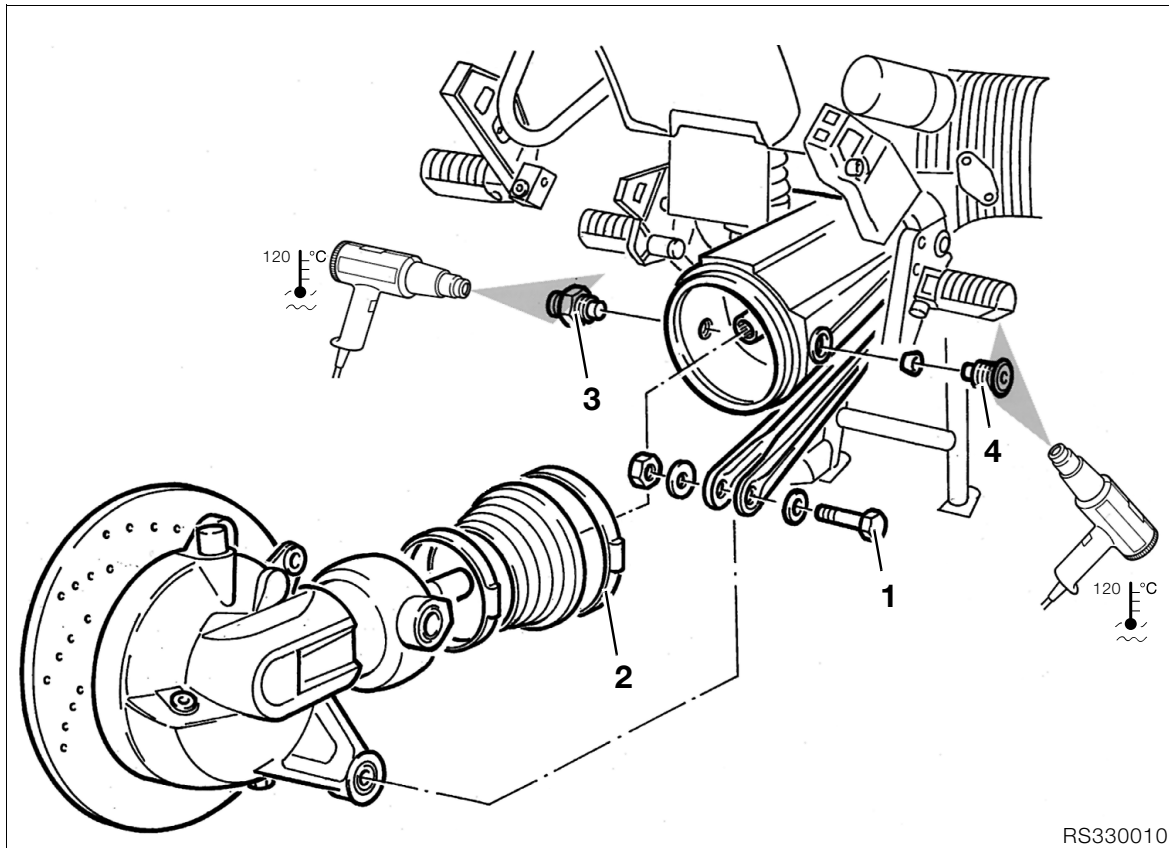

## Removing, dismantling, reassembling and installing rear wheel drive

- Drain the oil.
- **[RS]** Remove number plate carrier.
- **[GS]** Remove rear wheel cover at rear wheel drive.
- Unfasten brake caliper/secure to rear frame with cable strap.
- **[ABS]/[GS/R/RT]** Remove sensor.

### Removing rear wheel drive

- Remove rear wheel.
- Loosen strut at rear wheel drive (1).
- Release clamping strap (2).
- Heat free bearing journal (3) to max. 120 °C/loosen; heat fixed bearing journal (4) to max. 120 °C/loosen.
- **[RS/R/RT]** Remove brake disk/heat retaining bolts to 120 °C, with **[ABS]** mark position before removing.
- Remove free bearing/fixed bearing journal (3/4).



**Note:**  
Inner races of needle bearings.

- Detach strut from rear wheel drive.
- Disconnect rear wheel drive from drive shaft.



### Note:

If rear wheel drive is filled with oil, do not place on side prior to installation: this will cause oil to escape later, when the bike is ridden (suction effect).

### Removing input bevel pinion

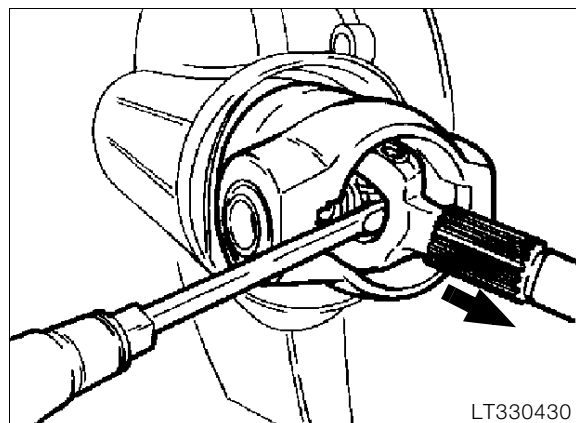

- Press out splined section of shaft.
- If necessary, remove/install circlip.

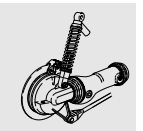

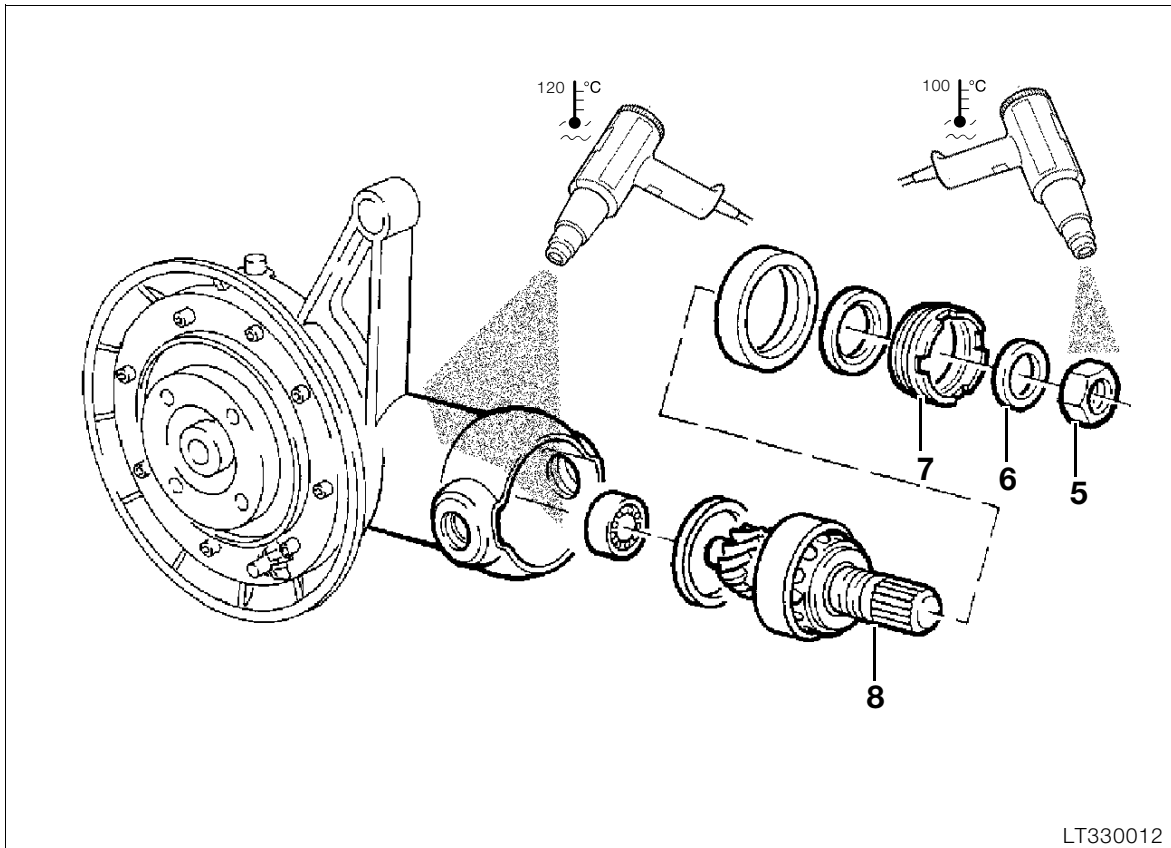

LT330012

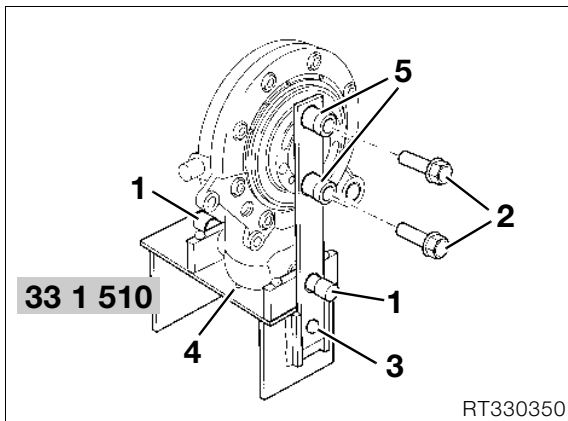

RT330350

- Bolt rear wheel drive centrally onto retaining fixture, **BMW No. 33 1 510**, with bearing journal (1).
- Bolt the locking arm (3) on tight.
- Move threaded sockets (5) up to rear wheel drive.
- Tighten with wheel studs (2).
- Tighten grub screws (4) until they make contact.

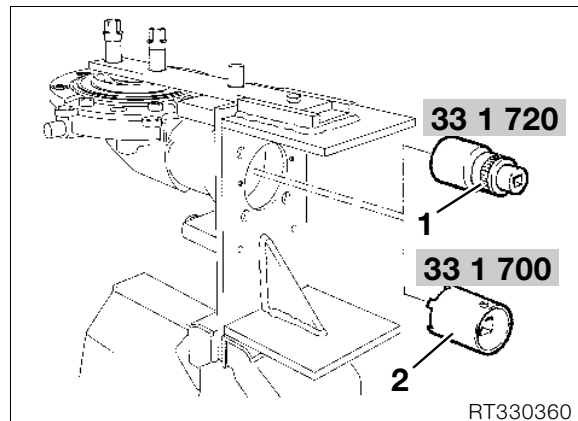

RT330360

- Heat hex nut (5) at input bevel pinion to 100 °C and unscrew it with 36 mm socket wrench insert and reducing adapter (1), **BMW No. 33 1 720**



**Caution:**

Never use a hammer when loosening the hex nut: this could damage the splines.

- Remove thrust ring (6).
- Heat housing to 120 °C and unscrew threaded ring (7) with pin wrench (2), **BMW No. 33 1 700**.
- To remove the input bevel pinion (8), heat bearing seat to 120 °C.

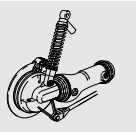

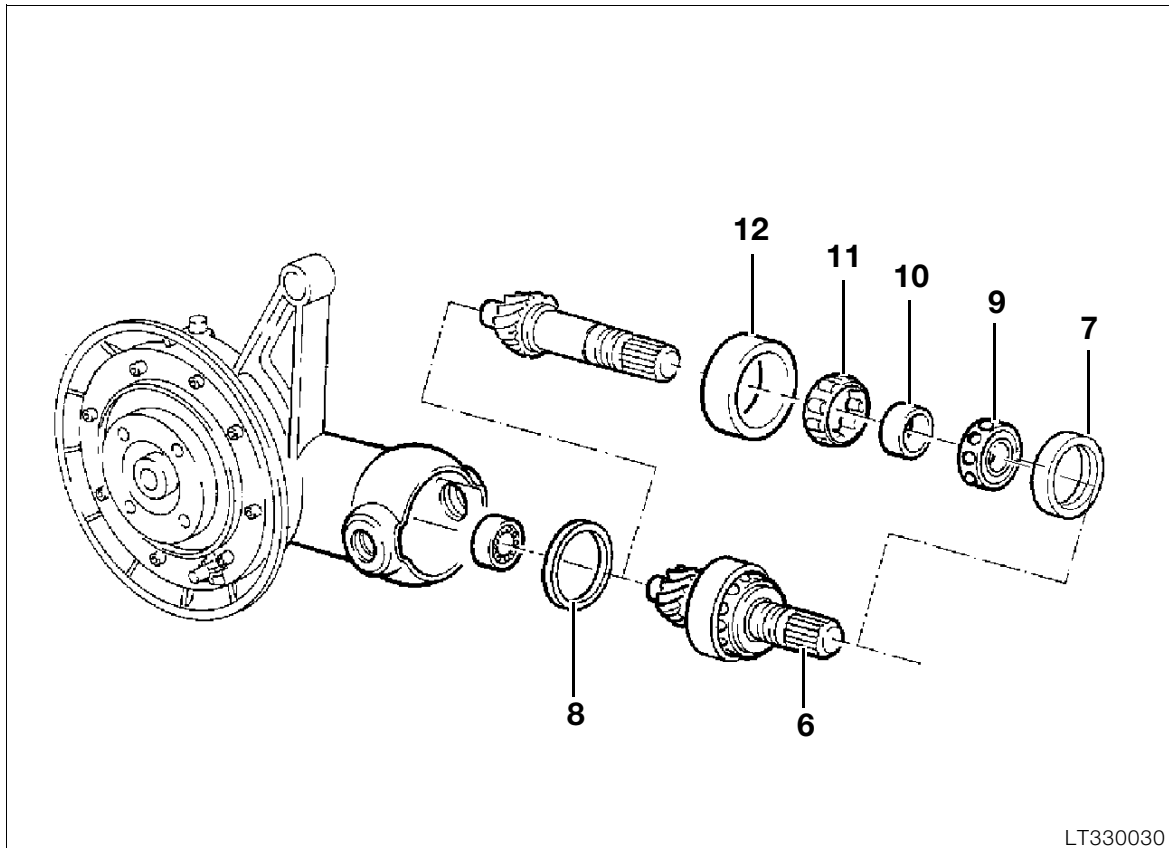

### Disassembling input bevel pinion

- Remove outer bearing race (7).
- Remove spacer ring (8) from housing.
- Clamp input bevel pinion (6) into vise with protective jaws (splines facing upwards).

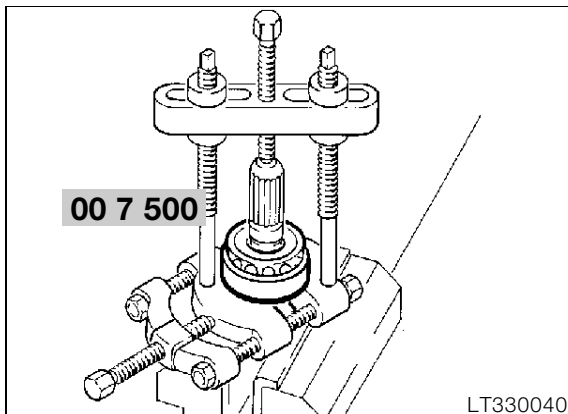

- Using puller, **BMW No. 00 7 500**, pull off both bearings at the same time.
- Take off ball thrust bearing (9), inner race (10), roller bearing cage (11) and outer race (12)

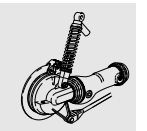



### Removing needle roller bearing for input bevel pinion

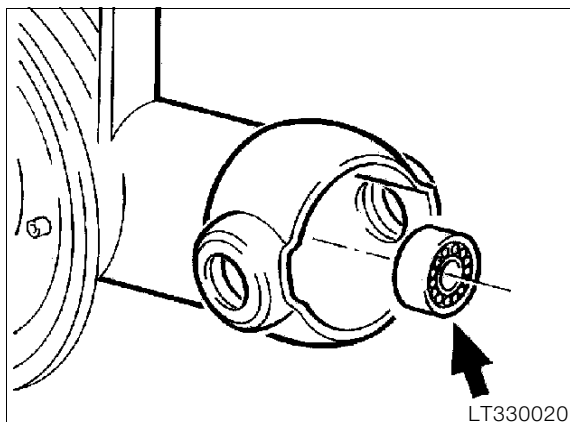

- Split the needle roller bearing cage open.
- Heat the housing to 130 °C..

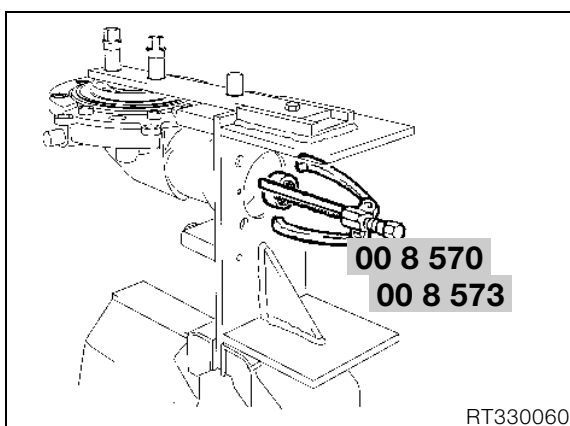

- Pull out the needle roller bearing outer race with internal puller, **BMW No. 00 8 573**, and counter-support, **BMW No. 00 8 570**.

### Installing needle roller bearing for input bevel pinion

- Heat the needle roller bearing seat to 100 °C.
- Press in needle roller bearing using drift or the input bevel pinion.

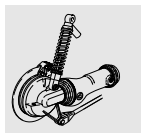

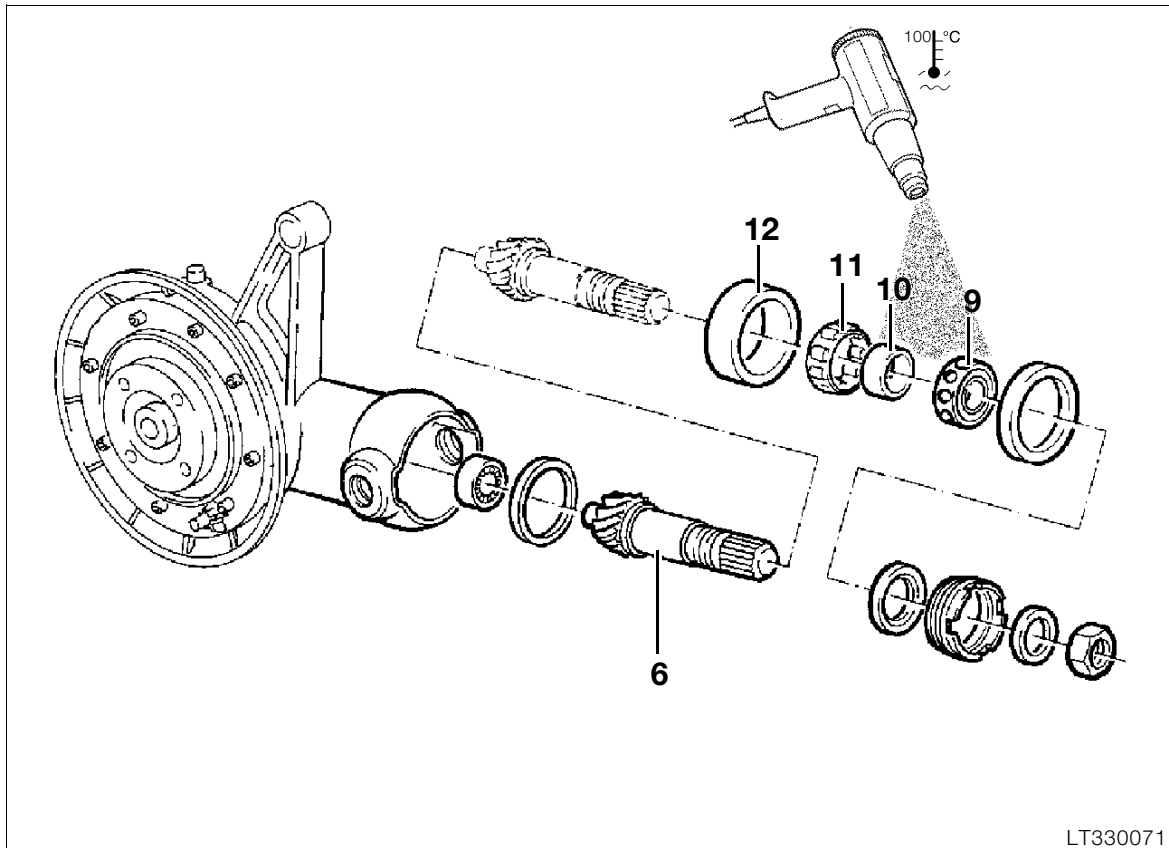

LT330071

### Assembling input bevel pinion

- Heat the inner race (10) to 100 °C and push onto input bevel pinion (6) as far as the stop.
- Slide outer race (12) together with roller cage (11) onto inner race (10).
- Heat ball thrust bearing (9) to 100 °C and push onto input bevel pinion (6) as far as the stop.
- Allow input bevel pinion to cool down.

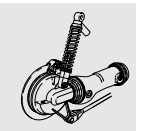

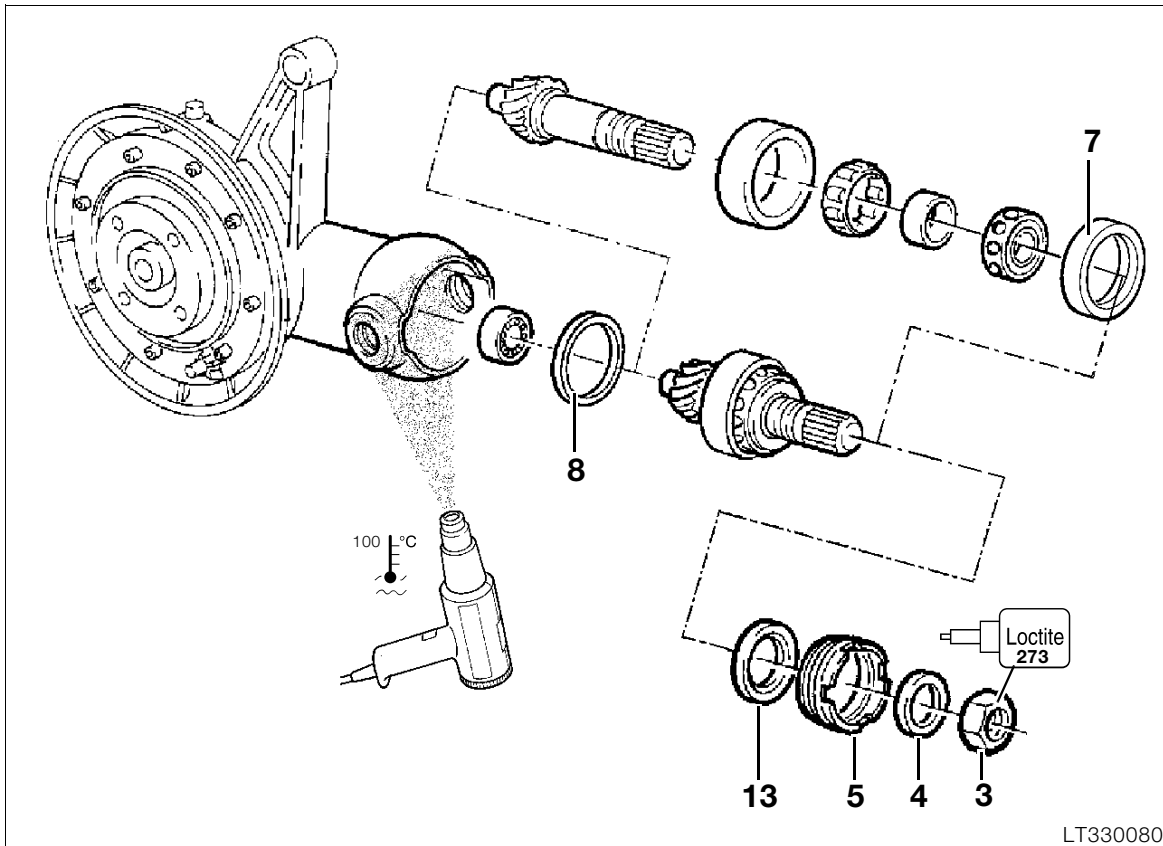

### Installing input bevel pinion

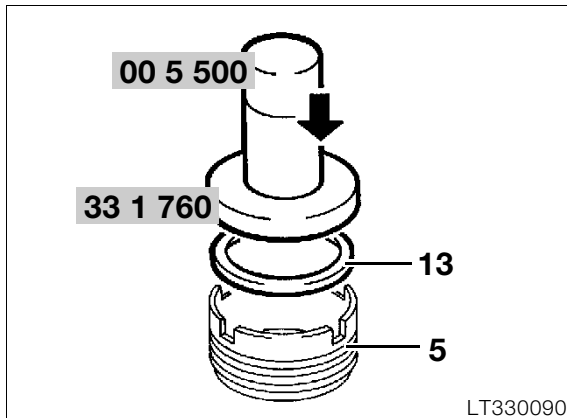

#### Note:

Ensure that lip of shaft seal is perfectly aligned on thrust ring.

- Tighten hex nut (3), using **Loctite 273**.



#### Caution:

Nut must not damage shaft sealing ring.



#### Tightening torque:

Threaded ring  
(thread cleaned + Hylomar SQ 32 M) ..... 118 Nm  
Nut for input bevel pinion  
(thread cleaned + Loctite 273)..... 200 Nm

- Drive sealing ring (13) into threaded ring (5) with drift, **BMW No. 00 5 550**, and handle, **BMW No. 33 1 760**.
- Heat the housing to 120 °C.
- Install input bevel pinion together with spacer disc (8).
- Insert outer race (7).
- Coat threaded ring (5) with **Hylomar SQ 32 M**.
- Tighten threaded ring with pin wrench, **BMW No. 33 1 700**.
- Install thrust ring (4).

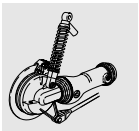

## Removing and installing taper roller bearing in rear wheel drive

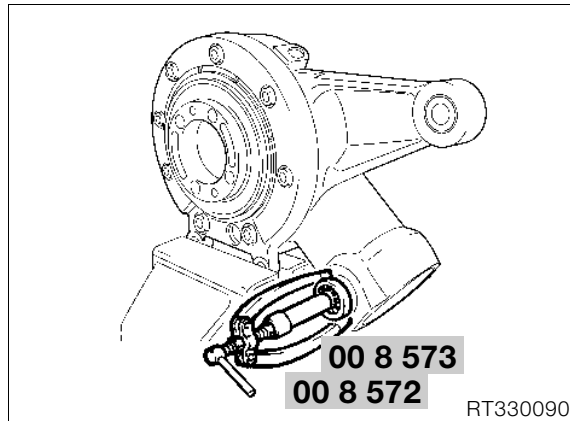

- Pull out needle roller bearing using counter-support 22/1, **BMW No. 00 8 572**, and internal puller 21/4, **BMW No. 00 8 573**.
- Heat neck of housing to 120 °C.
- Press in needle roller bearing with inner race on drift, **BMW No. 36 3 700**.

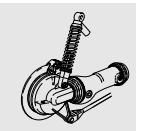

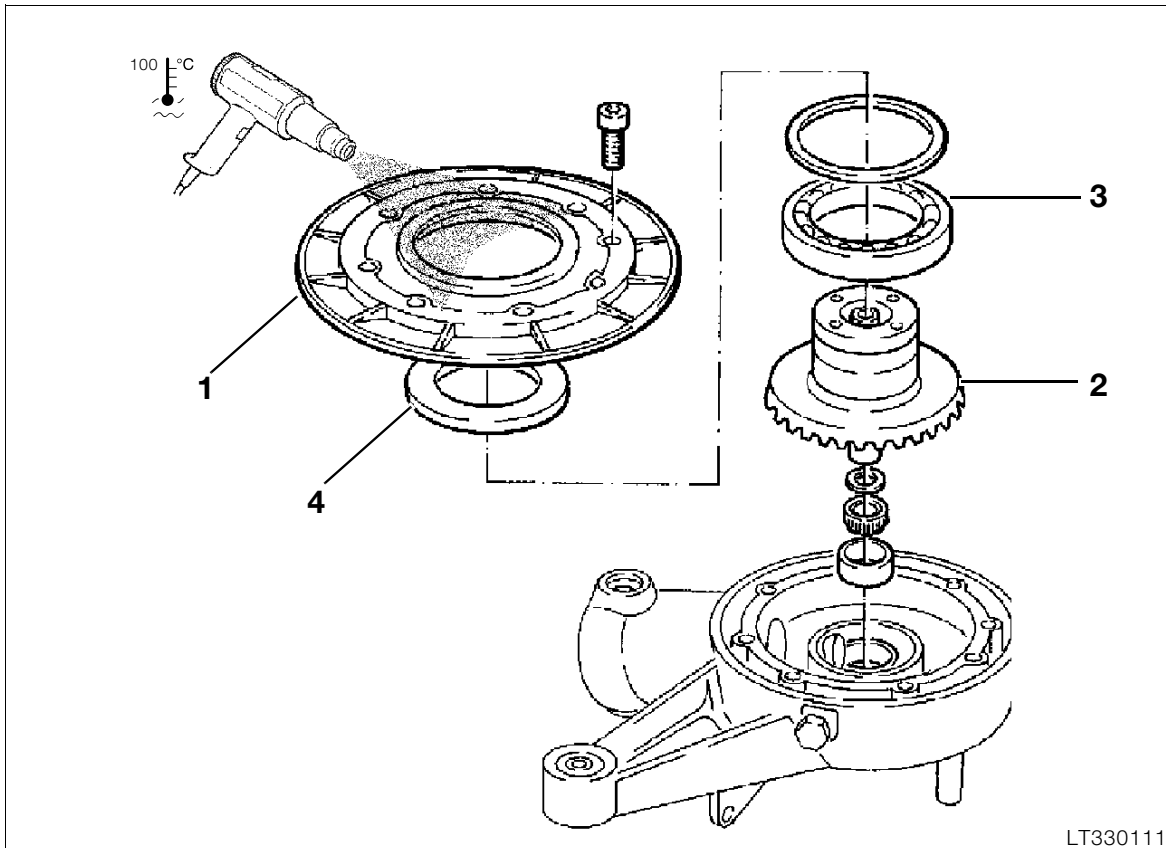

### Removing crown wheel

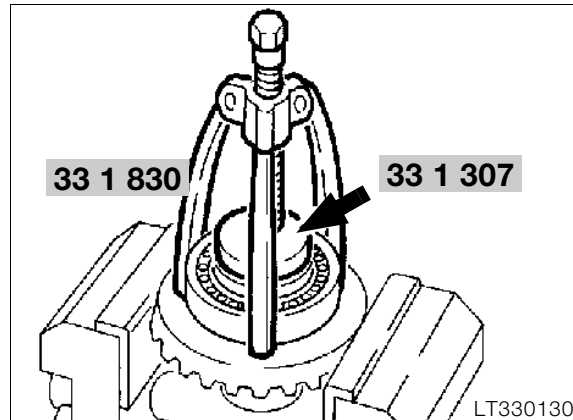
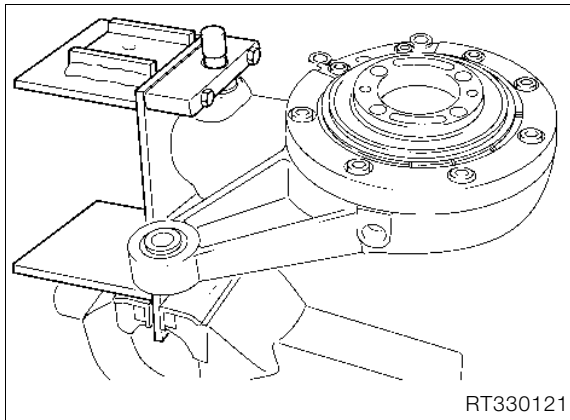

- Remove housing cover (1) with crown wheel (2) and bearing (3).
- Heat housing cover to 100 °C and pull it off.
- Force shaft seal (4) out of housing cover with drift.

- Clamp crown wheel in vise with protective jaws..
- Insert pressure block, **BMW No. 33 1 307** (arrow).
- Using puller, **BMW No. 33 1 830**, pull off the deep-groove ball bearing.

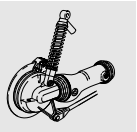

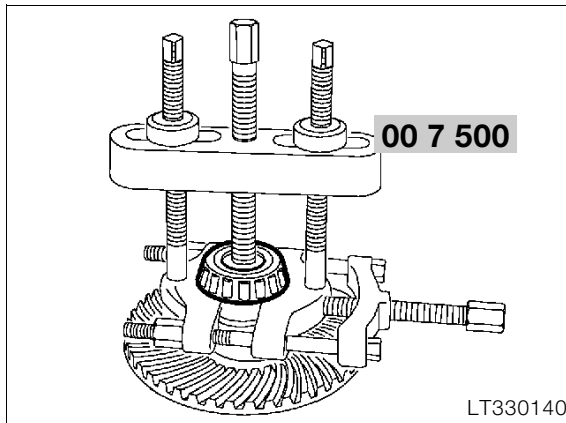

- Using puller, **BMW No. 00 7 500**, pull taper roller bearing off crown wheel.

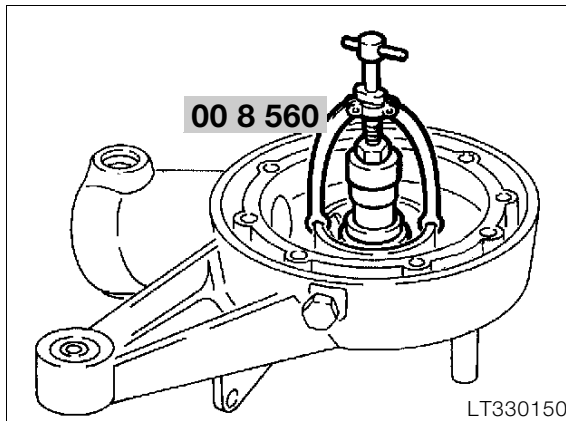

- Pull out the outer race using internal puller, **BMW No. 00 8 560**.

## Installing crown wheel

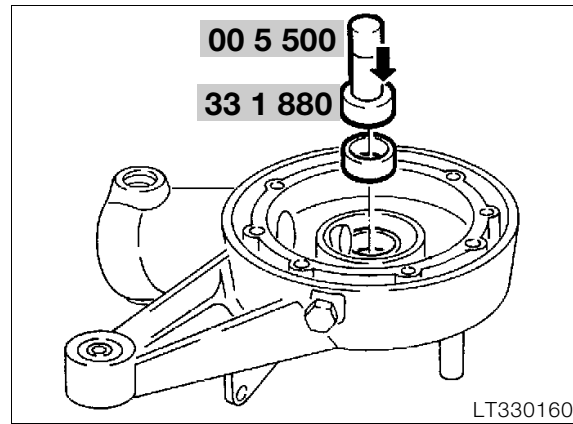

- Heat the housing to 80 °C.
- Insert the outer race in the bearing seat with drift, **BMW No. 33 1 880**, and handle, **BMW No. 00 5 500**.
- Check that outer race is correctly fitted by striking gently.



### Note:

If new parts are installed (e.g. taper roller bearing), check tooth backlash and adjust if necessary.

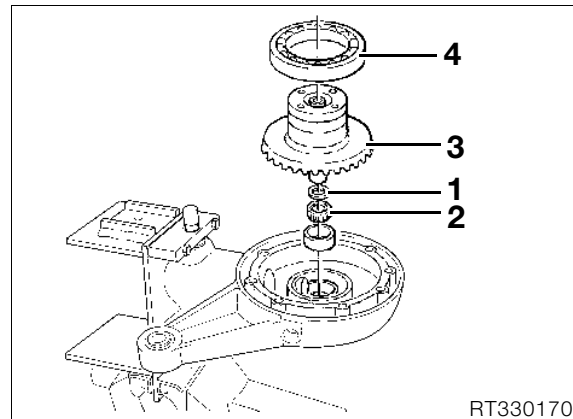

- Place the existing spacer ring (1) on the crown wheel.
- Heat taper roller bearing (2) to 80 °C and push it on.
- Install crown wheel (3).
- Heat deep-groove ball bearing (4) to 80 °C and place it in position.

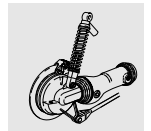

## Checking/adjusting backlash

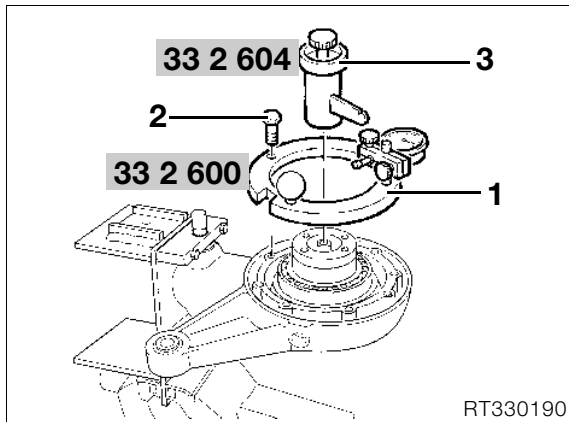

- Place measuring fixture (1), **BMW No. 33 2 600**, with dial gauge on the crown wheel and secure to housing with knurled screw (2).
- Attach measuring arm (3), **BMW No. 33 2 604**, centrally to crown wheel

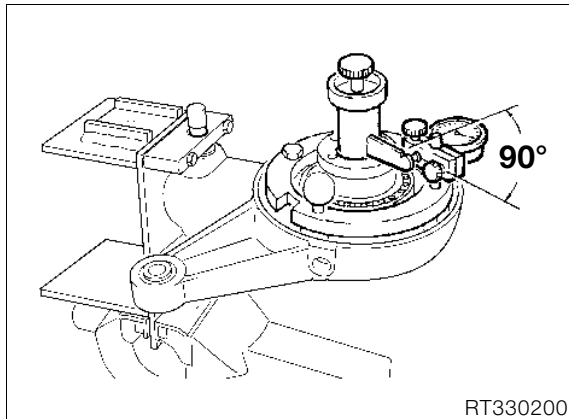

- With the palm of the hand, press the crown wheel into the housing and turn to and fro to check tooth backlash.



### Note:

Check tooth backlash at three points 120 degrees apart; turn the bevel pinion with the crown wheel.

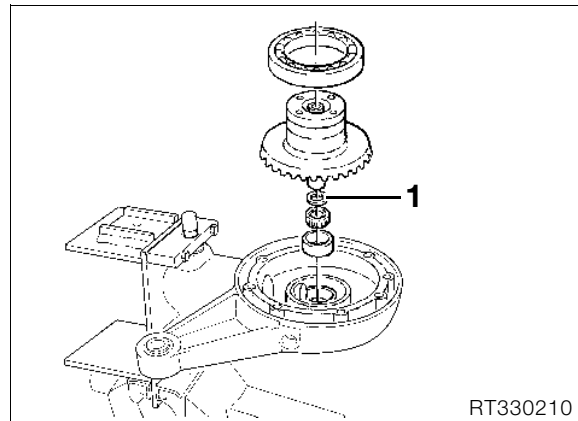

- Compensate for excessive backlash by inserting a thinner shim washer, and for insufficient backlash by inserting a thicker shim washer (1).

### Backlash:

(adjusting without oil).....0.07...0.16 mm  
 ..... (0.00276...0.0063 in)

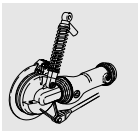

## Checking tooth contact pattern

- The tooth contact pattern must be checked if the gear set, housing or input bevel pinion bearing have been renewed

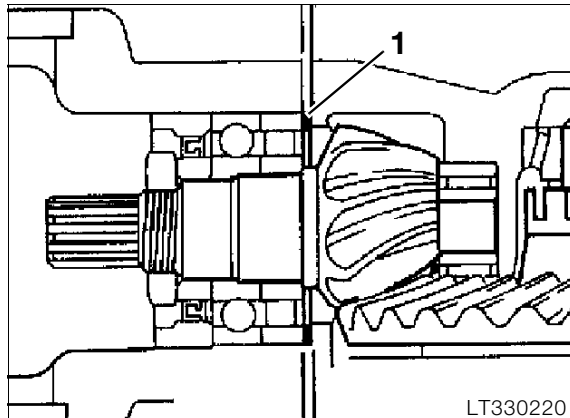

### Note:

The contact pattern is adjusted at the shim washer (1) on the input bevel pinion.

- Degrease the tooth flanks on crown wheel and pinion, and coat with **engineer's blue**.
- Insert the crown wheel, press into housing with the palms of the hands and turn to and fro.

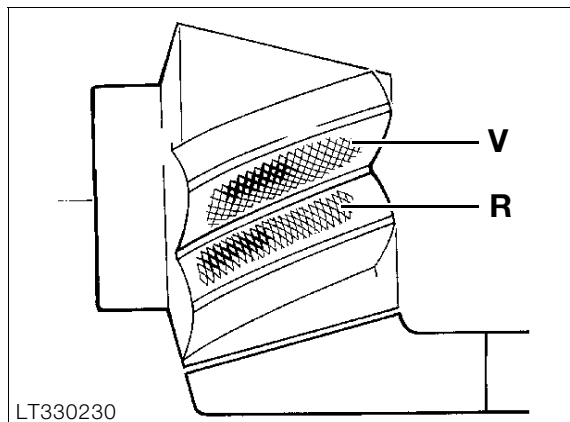

- If the correct spacer disc is installed, the following contact pattern appears when no load is applied.



### Note:

The contact point is central on front flank V.  
The contact point is closer to the larger diameter on back flank R.



### Caution:

Teeth should never make contact at the smaller diameter.

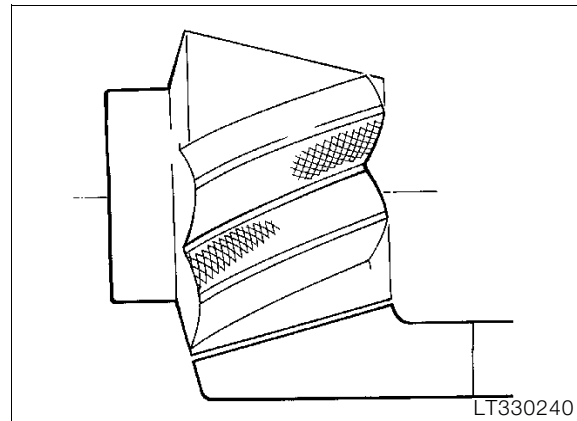

- If this contact pattern is obtained, a thinner shim washer must be installed.

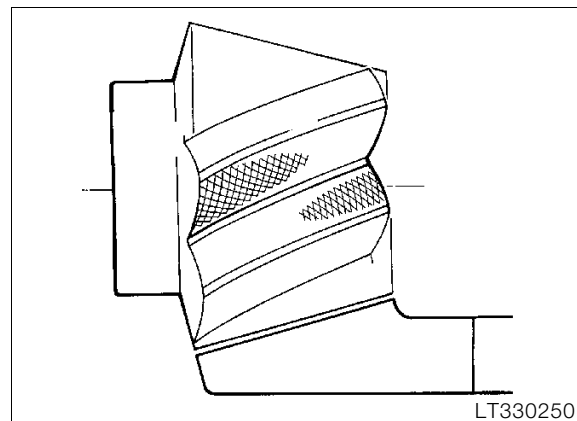

- If this contact pattern is obtained, a thicker shim washer must be installed.

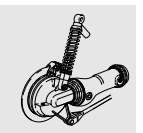



## Shimming housing cover

- To obtain the correct roller bearing preload, the housing cover must be shimmed

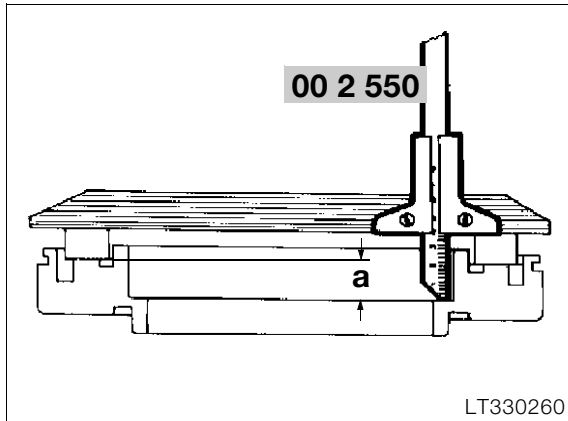

- Using depth gauge, **BMW No. 00 2 550**, measure distance a.

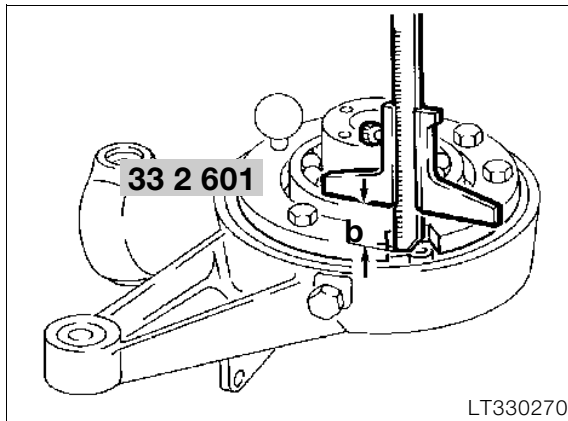

- Place measuring ring, **BMW No. 33 2 601**, in position and secure.
- Measure from the outer ball bearing race through the cutout in the measuring ring to the housing joint face and determine distance b.
- Distance a – distance b = shim thickness (without preload).
- Apply a light coat of grease to the selected shim washer, and install it.

**Preload:**..... 0.05...0.1 mm (0.00197...0.03937in)

## Installing housing cover

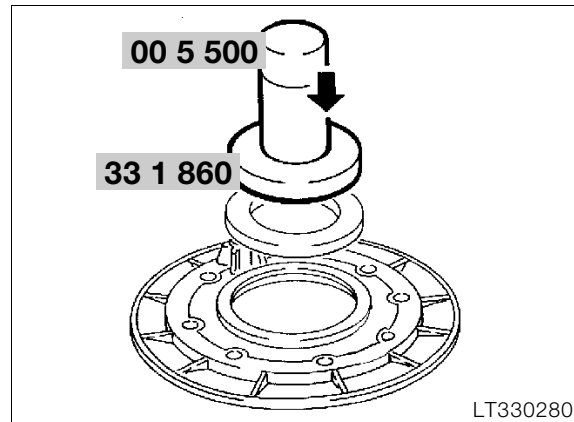

- Using drift, **BMW No. 00 5 500**, and handle, **BMW No. 33 1 860**, drive in the sealing ring.
- Install O-ring and apply a light coat of oil/grease.
- Heat housing cover to 80 °C/install.
- Tighten retaining bolts in a crosswise pattern

**Tightening torque:**  
Housing cover..... 35 Nm

## Installing splined element

- Coat splines on input pinion with **Staburags NBU 30 PTM**.
- Fit sliding element to drive pinion.
- Locate retaining ring with gentle blows (plastic hammer).

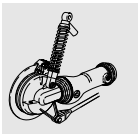

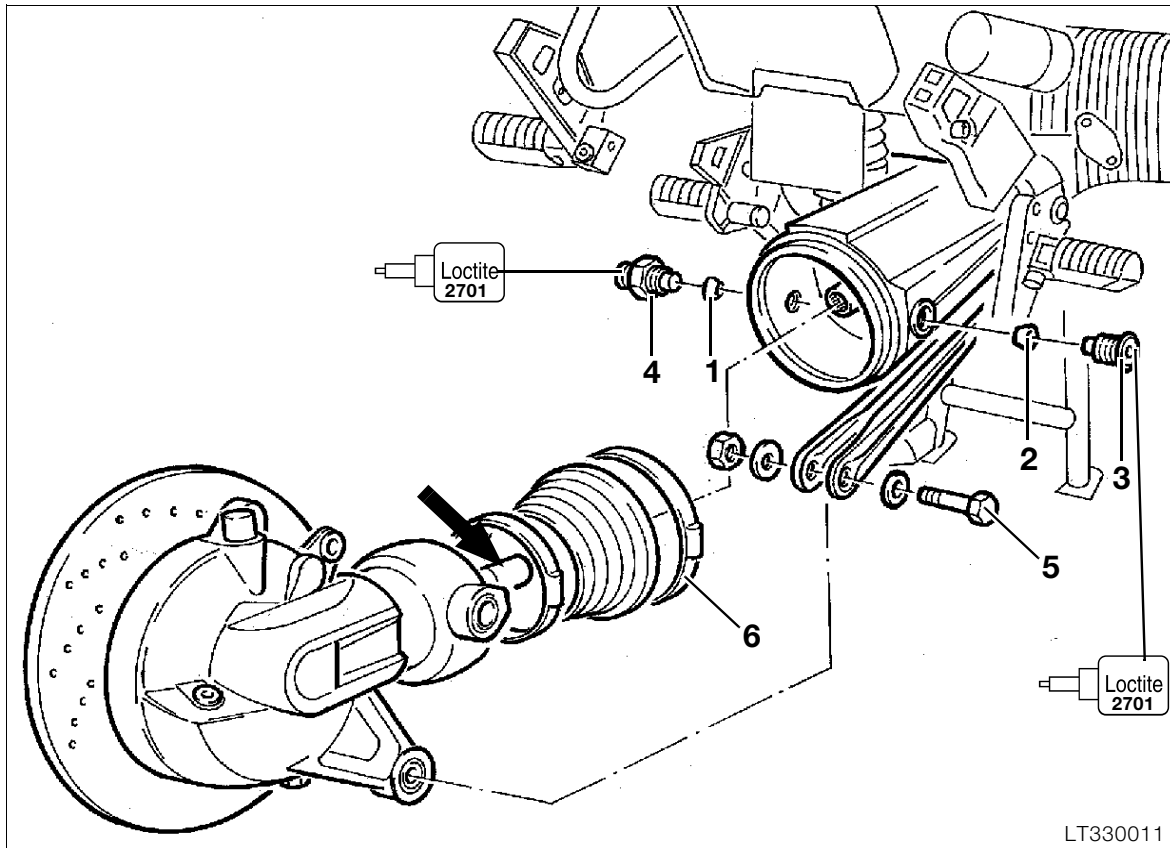

### Installing rear wheel drive

- Coat splines at sliding element (arrow) with **Staburags NBU 30 PTM**.
- Apply a small amount of grease to the inner race (1, 2) of the left needle roller bearing and install it.
- Install rear wheel drive with gaiter; insert sliding section into drive shaft.

**! Caution:**  
Support the rear wheel drive.

- Screw in fixed bearing journal (3) using **Loctite**.

**! Caution:**  
The inner race must never press against the ends of the needles.

- Apply **Loctite** to the entire length of the thread on free bearing pin (4), and screw it in.
- Tighten fixed bearing of swinging arm.

**! Tightening torque:**  
Fixed bearing journal  
(thread cleaned + Loctite 2701)..... 150 Nm

**! Caution:**  
When threaded connections are made with the aid of Loctite 2701, they must be tightened to their final torque without delay.  
The Loctite hardening time is at least 3 hours.

**! Note:**  
Use an acetone-based cleaning agent, e.g.  
Loctite Rapid Cleanser 706  
Loctite Order No. 70636-AC

- Tighten idler bearing for swinging arm.

**! Tightening torque:**  
Free bearing journal  
(thread cleaned + Loctite 2701 applied to complete length of thread on free bearing pin)..... 7 Nm  
Locknut..... 105 Nm

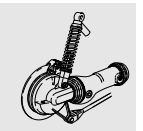

- Apply a weight of approx. 85 kg to the motorcycle and tighten the strut (5) previously loosened.

 **Tightening torque:**

Reaction link to rear wheel drive..... 43 Nm

- Tighten clamping strap (6) on gaiter.
- If necessary, fill with oil.

**Fill quantity:**

Initial filling.....0.25 l (0.44 Imp. pints)

During oil changes .....0.23 l (0.405 Imp. pints)

**Oil grade:**

Brand-name hypoid gear oil, SAE 90, API class GL 5

- **[ABS]/[RS/R/RT]** Install the brake disc in the previously marked position.
- Install the rear wheel.
- Install brake caliper.



**Caution:**

Do not damage brake pads; do not tilt when installing.

- **[GS/R/RT]/[ABS]** Install the sensor.
- **[ABS]** Check that sensor gap is correct.

**ABS rear sensor gap:** .....0,45...0,55 mm  
 ..... (0.0177...0.02165 in)

- **[RS]** Install the number plate holder.
- **[GS]** Install the rear wheel cover.

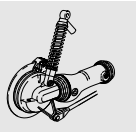

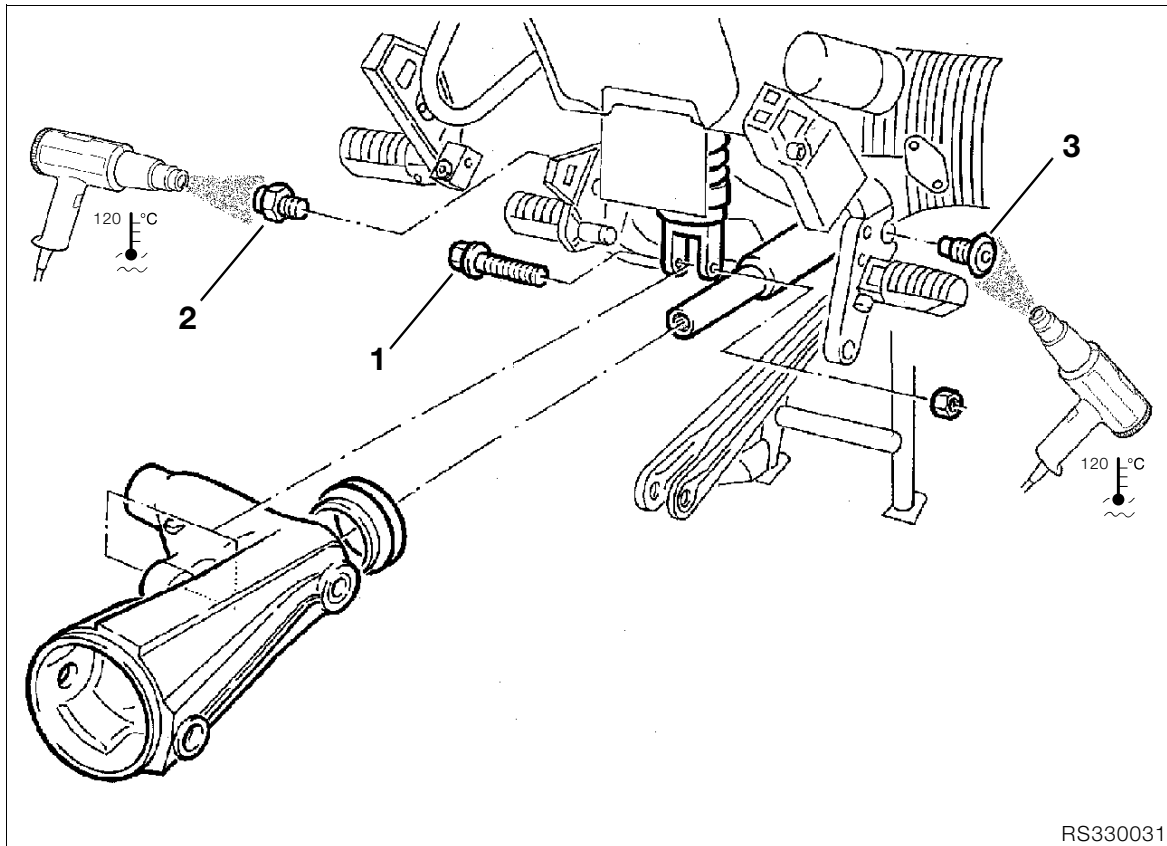

RS330031

## Removing, dismantling, reassembling and installing rear swinging arm

### Removing rear swinging arm

- Unfasten suspension strut mount (1).
- **[RT]** Detach brake master cylinder from right footrest plate.
- **[RT]** Detach gear shift linkage from left footrest plate.
- **[RT]** Remove right and left footrest plates.
- Heat free swinging arm bearing (2) to max. 120 °C/loosen.
- Heat fixed swinging arm bearing (3) to max. 120 °C/unscrew.
- Unfasten free swinging arm bearing

### Removing and installing taper roller bearing

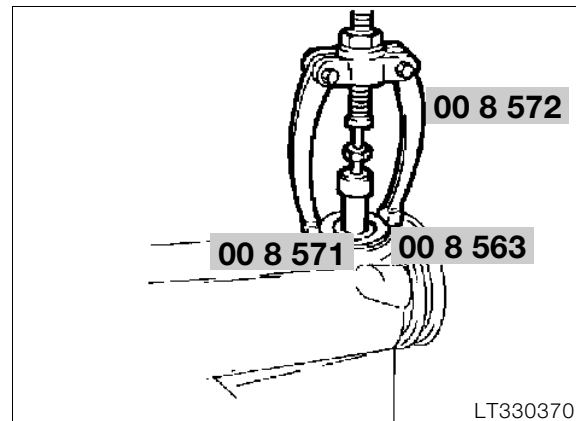

LT330370

- Using counter-support, **BMW No. 00 8 572**, and internal puller 21/2, **BMW No. 00 8 571**, pull out taper roller bearing.
- Pull out outer race with internal puller 21/5, **BMW No. 00 8 563**.
- To install the bearing, heat the swinging arm to 80 °C.

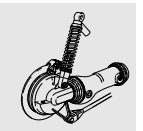

## Removing and installing flexible gaiter

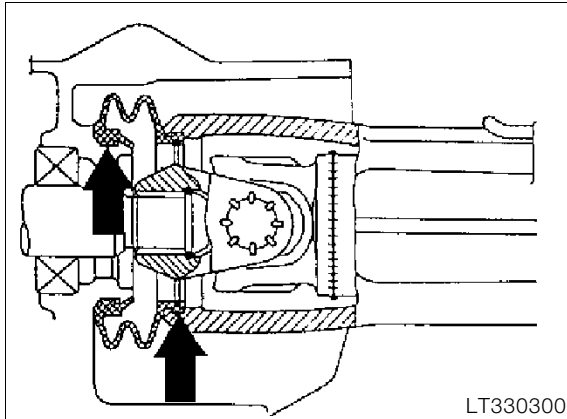

- Remove inner retaining ring; remove gaiter from swinging arm.
- When installing, coat inner and outer sealing lips (arrows) with **Staburags NBU 30 PTM**.



### Caution:

Drive shaft clearance when suspension is compressed: aperture in retaining ring must be horizontal.

## Checking universal joint for wear

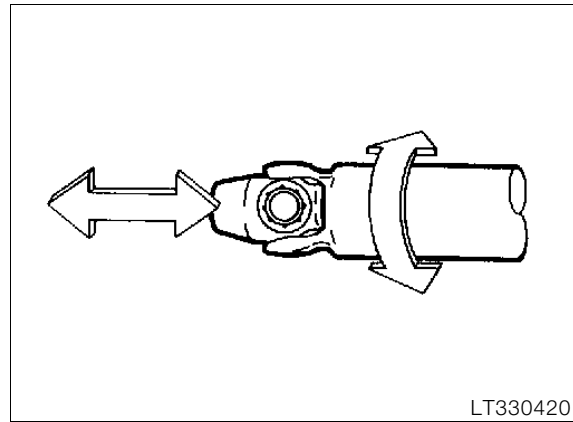

- Determine end float and face runout.

## Installing drive shaft

- Coat the splines on the output shaft with **Staburags NBU 30 PTM**.
- Fit drive shaft to output shaft.
- Engage the snap ring with gentle blows (plastic hammer).

## Removing drive shaft

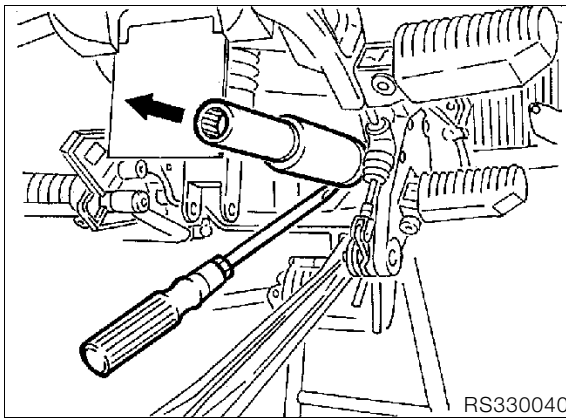

- Press off drive shaft.



### Caution:

Do not scratch painted components: if necessary, use a rubber mat.

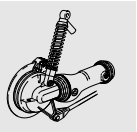

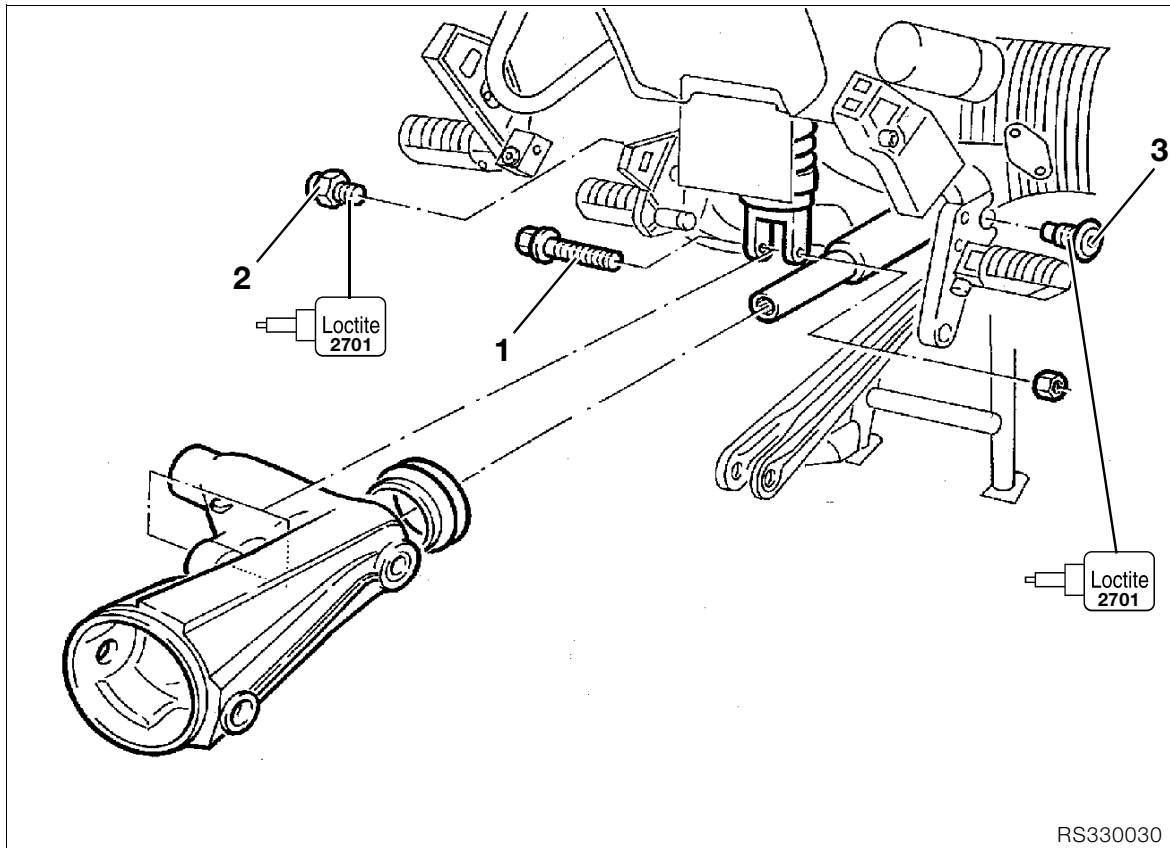

## Installing rear swinging arm

- Slide swinging arm over drive shaft as far as possible until rubber gaiter connects on housing neck.
- Screw in fixed bearing journal (3) with **Loctite**.
- Apply **Loctite** to the entire length of the thread on free bearing pin (2) and screw it in.
- Tighten fixed bearing journal.

### **Tightening torque:**

Fixed bearing journal  
(thread cleaned + Loctite 2701) ..... 150 Nm

### **Caution:**

When threaded connections are made using Loctite 2701, the final tightening torque must be applied without delay.  
The Loctite has a hardening time of at least 3 hours.

### **Note:**

Use acetone-based cleaning agents, e.g.  
Loctite Rapid Cleanser 706  
Loctite Order No. 70636-AC

- Tighten free bearing journal.

### **Tightening torque:**

Free bearing journal  
(Thread cleaned + Loctite 2701 applied to entire  
length of thread on free bearing journal)  
..... 7 Nm  
Locknut..... 105 Nm

- **[RT]** Attach gear shift linkage to left footrest plate.
- **[RT]** Install left and right footrest plates.
- **[RT]** Attach brake master cylinder to right footrest plate.
- Secure suspension strut (1).

### **Tightening torque:**

Suspension strut to swinging arm  
**[RS]** (8.8 screw) ..... 43 Nm  
**[RS]** (10.9 screw) ..... 50 Nm  
**[GS/R/RT]** (10.9 screw) ..... 50 Nm

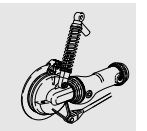

## Removing and installing suspension strut

- Remove dualseat.
- **[RT]** Remove small left/right side sections of fairing.
- Remove rear wheel.

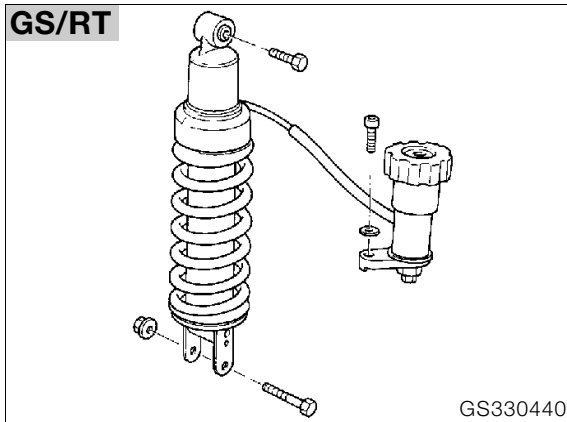
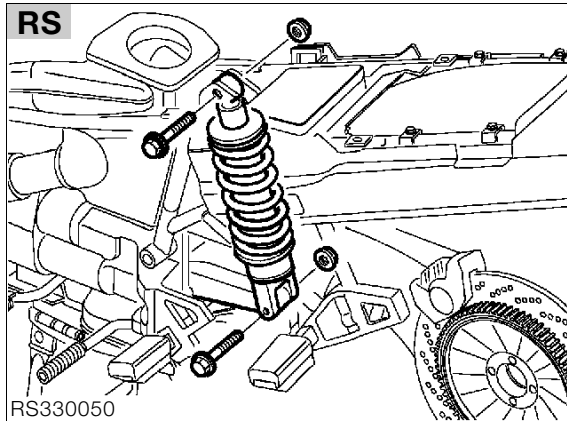

- **[GS]** Unscrew hydraulic spring adjuster using 6 mm Allen key, **BMW No. 31 5 600**.
- Remove/install suspension strut.



### ! Tightening torque:

Suspension strut on swinging arm/rear frame	
<b>[RS]</b> (8.8 screw) .....	43 Nm
<b>[RS]</b> (10.9 screw) .....	50 Nm
<b>[GS/R/RT]</b> (10.9 screw) .....	50 Nm
Hydraulic spring adjuster at footrest plate .....	22 Nm

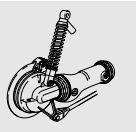

# 34 Brakes

## Contents

Page

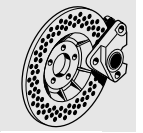

<b>Technical Data</b> .....	3
<b>Removing and installing front brake caliper</b> .....	7
<b>Dismantling and assembling front brake caliper</b> .....	8
Dismantling front brake caliper .....	8
Assembling front brake caliper .....	8
<b>Removing and installing rear brake caliper</b> .....	9
<b>[RS] Dismantling and assembling rear brake caliper</b> .....	10
Dismantling rear brake caliper .....	10
Assembling rear brake caliper .....	11
<b>[GS/R/RT] Dismantling and re-assembling rear brake caliper</b> .....	12
Dismantling rear brake caliper .....	12
Assembling rear brake caliper .....	12
<b>Removing and installing front brake disc</b> .....	13
<b>[RS] Removing and installing rear brake disc (attached to rear wheel drive)</b> .....	14
<b>[GS/R] Removing and installing rear brake disc (attached to rear wheel hub)</b> .....	14
<b>[RT/R] Removing and installing rear brake disc (attached to rear wheel drive)</b> .....	15
<b>[RS] Removing and installing front ABS sensor</b> .....	16
<b>[GS/R] Removing and installing front ABS sensor</b> .....	17
<b>[RT] Removing and installing front ABS sensor</b> .....	18
<b>[ABS] Adjusting front sensor gap</b> .....	19
Marking sensor wheel .....	19
Checking and adjusting sensor gap .....	19
<b>[RS] Removing and installing rear ABS sensor</b> .....	20
<b>[GS/R/RT] Removing and installing rear ABS sensor</b> .....	21



# Contents

Page

## **[RS] Adjusting rear ABS sensor gap** .....22

Marking sensor wheel .....22

Checking and adjusting sensor gap .....22

## **[GS/R/RT] Adjusting rear ABS sensor gap** .....23

Marking sensor wheel .....23

Checking and adjusting sensor gap .....23

## **Removing, installing, dismantling and assembling front brake master cylinder** .....24

Adjusting specification for handbrake lever .....24

## **Removing and installing rear brake master cylinder** .....25

Checking and adjusting relief clear-ance of piston rod .....25

## **Removing and installing brake pedal** .....26

## **Removing and installing ABS unit** .....27

Removing the ABS unit .....28

Installing the ABS unit .....28

## **Removing and installing ABS relay and relay base** .....29

Removing ABS relay .....29

Installing the ABS relay .....29

Removing ABS relay base .....30

Installing the ABS relay base .....30

## **Removing and installing brake line (with ABS)** .....32

Removing and installing front ABS brake line .....32

## **Removing and installing rear ABS brake line** .....33

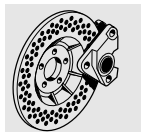

Technical Data		R 1100 RS
Brake fluid		DOT 4
Minimum lining thickness	mm (in)	1.5 (0.059)
<b>Front wheel</b>		
Brake disc dia.	mm (in)	305 (12.0079)
Brake disc thickness	mm (in)	5 $\pm$ 0.1 (0.1969 $\pm$ 0.003937)
Minimum thickness	mm (in)	4.5 (0.1772)
Brake pad surface area	cm <sup>2</sup> (sq.in)	100 (15,5)
Piston dia. in brake caliper	mm (in)	32/34 (1.2598/1.3386)
Piston diameter in handlebar lever cylinder	mm (in)	20 (0.787)
Sensor gap, front	mm (in)	0.45...0.55 (0.0177...0.02165)
Brake pad		Sintered metal
<b>Rear wheel</b>		
Brake disc dia.	mm (in)	285 (11.22)
Brake disc thickness	mm (in)	5.0 (0.1969)
Minimum thickness	mm (in)	4.6 (0.1811)
Permissible lateral runout	mm (in)	0.20 (0.00787)
Brake pad surface area	cm <sup>2</sup> (sq.in)	41.5 (6.4325)
Piston dia. in brake caliper	mm (in)	38 (1.496)
Piston dia. in foot brake cylinder	mm (in)	12 (0.4724)
Sensor gap, rear	mm (in)	0.45...0.55 (0.0177...0.02165)
Brake pad		Semi-metallic

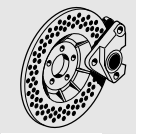



Technical Data		R 1100 RT
Brake fluid		DOT 4
Minimum lining thickness	mm (in)	Wear indicator
<b>Front wheel</b>		
Brake disc dia.	mm (in)	305 (12.0079)
Brake disc thickness	mm (in)	5± 0.1 (0.1969± 0.003937)
Minimum thickness	mm (in)	4.5 (0.1772)
Brake pad surface area	cm <sup>2</sup> (sq.in)	100 (15,5)
Piston dia. in brake caliper	mm (in)	32/34 (1.2598/1.3386)
Piston diameter in handlebar lever cylinder	mm (in)	20 (0.787)
Sensor gap, front	mm (in)	0.45...0.55 (0.0177...0.02165)
Brake pad		Semi-metallic
<b>Rear wheel</b>		
Brake disc dia.	mm (in)	276 (10.866)
Brake disc thickness	mm (in)	5.0 (0.1969)
Minimum thickness	mm (in)	4.5 (0.177)
Permissible lateral runout	mm (in)	0.15 (0.0059)
Brake pad surface area	cm <sup>2</sup> (sq.in)	34 (5.27)
Piston dia. in brake caliper	mm (in)	26 (1.0236) with insulating piston
Piston dia. in foot brake cylinder	mm (in)	12 (0.4724)
Sensor gap, rear	mm (in)	0.45...0.55 (0.0177...0.02165)
Brake pad		Semi-metallic

Technical Data		R 850 GS	R 1100 GS
Brake fluid		DOT 4	DOT 4
Minimum lining thickness	mm (in)	Wear indicator	Wear indicator
<b>Front wheel</b>			
Brake disc dia.	mm (in)	305 (12.0079)	305 (12.0079)
Brake disc thickness	mm (in)	5± 0.1 (0.1969± 0.003937)	5± 0.1 (0.1969± 0.003937)
Minimum thickness	mm (in)	4.5 (0.1772)	4.5 (0.1772)
Brake pad surface area	cm <sup>2</sup> (sq.in)	100 (15,5)	100 (15,5)
Piston dia. in brake caliper	mm (in)	32/34 (1.2598/1.3386)	32/34 (1.2598/1.3386)
Piston diameter in handlebar lever cylinder	mm (in)	20 (0.787)	20 (0.787)
Sensor gap, front	mm (in)	0.45...0.55 (0.0177...0.02165)	0.45...0.55 (0.0177...0.02165)
Brake pad		Semi-metallic	Semi-metallic
<b>Rear wheel</b>			
Brake disc dia.	mm (in)	276 (10.866)	276 (10.866)
Brake disc thickness	mm (in)	5.0 (0.1969)	5.0 (0.1969)
Minimum thickness	mm (in)	4.5 (0.177)	4.5 (0.177)
Permissible lateral runout	mm (in)	0.15 (0.0059)	0.15 (0.0059)
Brake pad surface area	cm <sup>2</sup> (sq.in)	34 (5.27)	34 (5.27)
Piston dia. in brake caliper	mm (in)	26/28 (1.0236/1.10236)	26/28 (1.0236/1.10236)
Piston dia. in foot brake cylinder	mm (in)	13 (0.512)	13 (0.512)
Sensor gap, rear	mm (in)	0.45...0.55 (0.0177...0.02165)	0.45...0.55 (0.0177...0.02165)
Brake pad		Semi-metallic	Semi-metallic

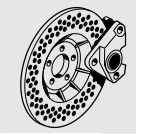



Technical Data		R 850 R	R 1100 R
Brake fluid		DOT 4	DOT 4
Minimum lining thickness	mm (in)	Wear indicator	Wear indicator
<b>Front wheel</b>			
Brake disc dia.	mm (in)	305 (12.0079)	305 (12.0079)
Brake disc thickness	mm (in)	5± 0.1 (0.1969± 0.003937)	5± 0.1 (0.1969± 0.003937)
Minimum thickness	mm (in)	4.5 (0.1772)	4.5 (0.1772)
Brake pad surface area	cm <sup>2</sup> (sq.in)	100 (15,5)	100 (15,5)
Piston dia. in brake caliper	mm (in)	32/34 (1.2598/1.3386)	32/34 (1.2598/1.3386)
Piston diameter in handlebar lever cylinder	mm (in)	20 (0.787)	20 (0.787)
Sensor gap, front	mm (in)	0.45...0.55 (0.0177...0.02165)	0.45...0.55 (0.0177...0.02165)
Brake pad		Semi-metallic	Semi-metallic
<b>Rear wheel</b>			
Brake disc dia.	mm (in)	276 (10.866)	276 (10.866)
Brake disc thickness	mm (in)	5.0 (0.1969)	5.0 (0.1969)
Minimum thickness	mm (in)	4.6 (0.1811)	4.5 (0.177)
Permissible lateral runout	mm (in)	0.15 (0.0059) Spoked wheel	0.15 (0.0059) Spoked wheel
	mm (in)	0.15 (0.0059) Cast wheel	0.15 (0.0059) Cast wheel
Brake pad surface area	cm <sup>2</sup> (sq.in)	34 (5.27)	34 (5.27)
Piston dia. in brake caliper	mm (in)	26/28 (1.0236/1.10236) with insulating piston	26/28 (1.0236/1.10236) with insulating piston
Piston dia. in foot brake cylinder	mm (in)	12 (0.4724)	12 (0.4724)
Sensor gap, rear	mm (in)	0.45...0.55 (0.0177...0.02165)	0.45...0.55 (0.0177...0.02165)
Brake pad		Semi-metallic	Semi-metallic

## Removing and installing front brake caliper

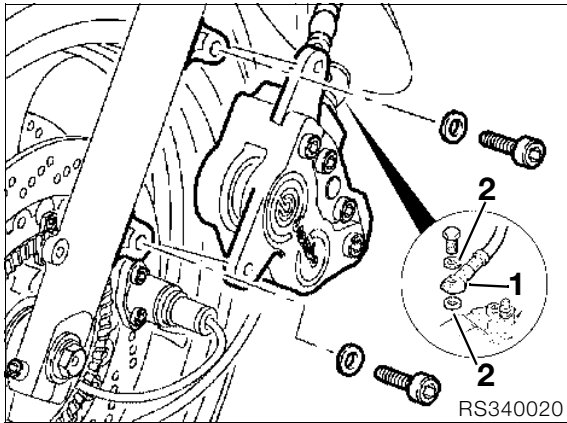

- Drain fluid from brake system.
- Detach brake line (1).

### **⚠ Caution:**

Do not allow brake fluid to come into contact with painted parts of the motorcycle, because brake fluid destroys paint.

- Unscrew the brake caliper.

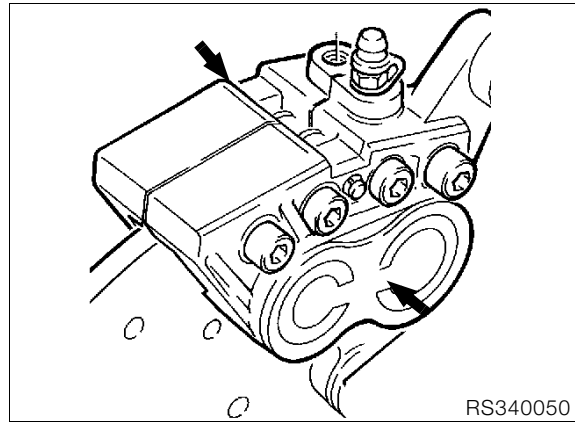

- Force back the brake pads/pistons (arrows).
- Carefully remove the brake caliper.

### **⚠ Caution:**

**[RS/R/RT]** Do not scratch the wheel rim; if necessary, mask off the brake caliper with tape. Do not damage brake pads.

- Install in the reverse order of work.
- Force back the brake pads/pistons.
- Fill/bleed the brake system.

### **⚠ Caution:**

Use new sealing rings (2). Do not damage brake pads.

### **⚠ Tightening torque:**

Brake caliper to slider tube ..... 40 Nm  
 Brake hose to brake caliper ..... 15 Nm  
 Bleed screw at brake caliper ..... 7 Nm

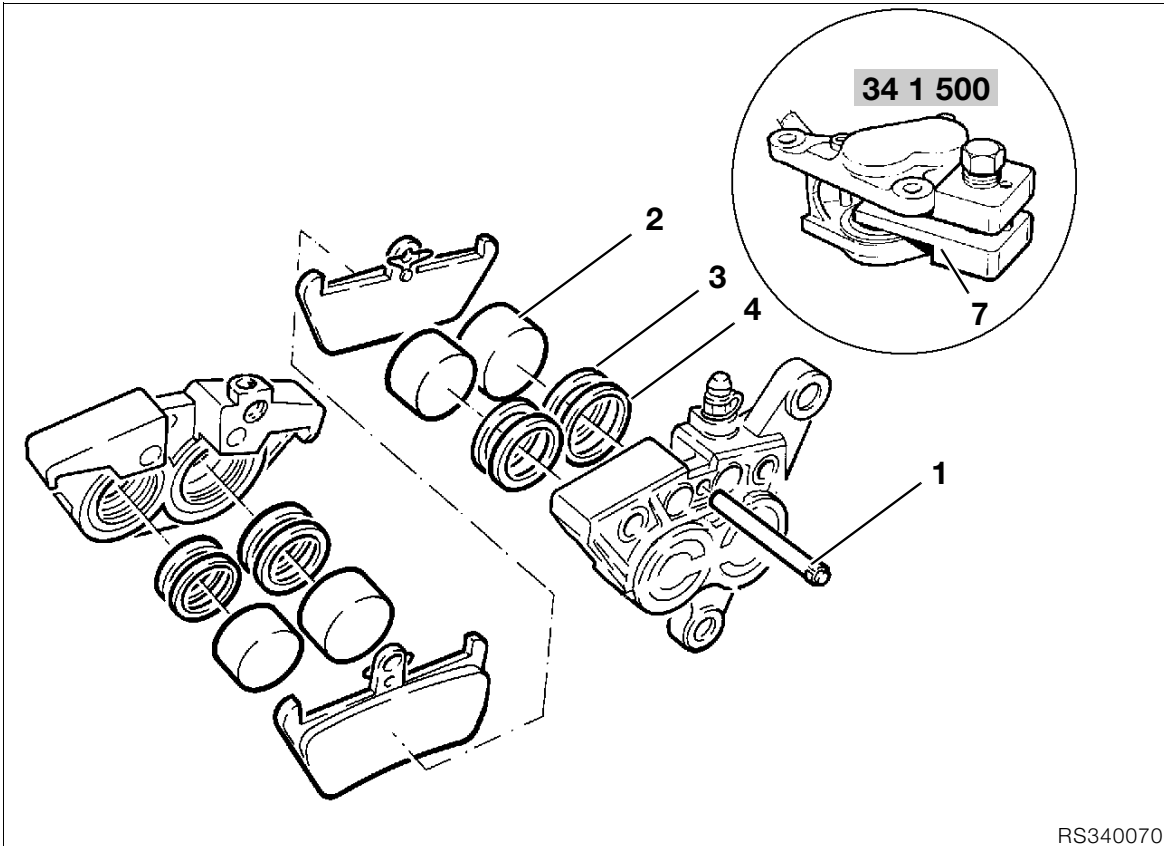

RS340070

## Dismantling and assembling front brake caliper



### Caution:

The brake caliper halves **must not be un-screwed!**

### Dismantling front brake caliper

- Remove the brake caliper.
- Remove keeper from retaining pin (1).
- Drive out the retaining pin (1) from the wheel side.
- Pull the brake pads out downwards.
- Seal the bleed screw.



### Tightening torque:

Bleed screw at brake caliper ..... 7 Nm

- Hold a cloth over the brake caliper.
- **Carefully** press out brake pistons (2), using a compressed air gun at the brake line connection.



### Caution:

Do not allow your fingers to become trapped between the pistons; risk of injury.

- Remove the two sealing rings (3,4) from the left/right brake cylinder bores.
- Examine the brake caliper pistons for damage.

### Assembling front brake caliper

- Coat new sealing rings (3,4) with brake fluid and install.
- Coat brake caliper pistons (2) with brake fluid and insert.



### Caution:

Do not tilt the brake pistons when installing.

- If necessary, press the pistons fully back with re-setting tool (7), **BMW No. 34 1 500**.
- Install the brake pads.

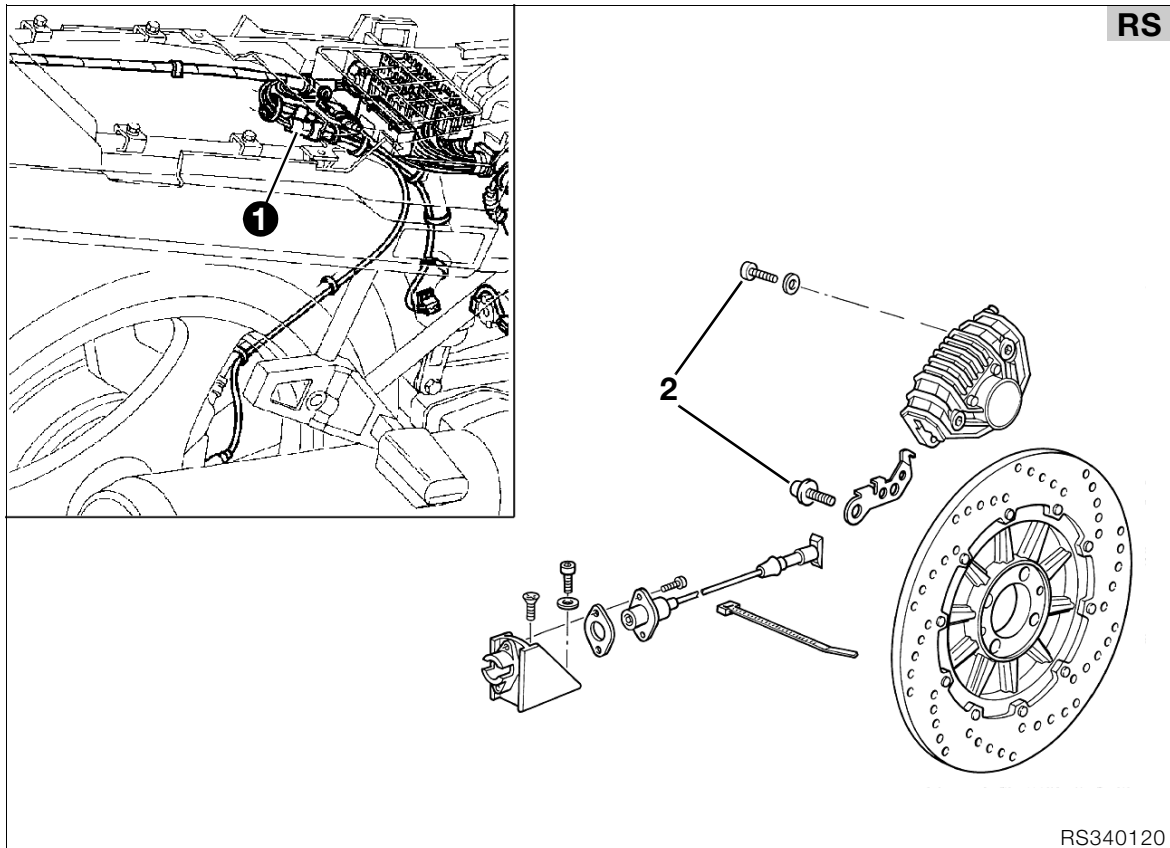

## Removing and installing rear brake caliper

- Drain fluid from brake system

### **Caution:**

Do not allow brake fluid to come into contact with painted parts of the motorcycle, because brake fluid destroys paint.

- Detach the brake line from the brake caliper.
- **[RS/ABS]** Detach the sensor line plug (1).
- Unscrew the brake caliper (2).
- Install in the reverse order of work.
- Force back the brake pads/pistons.
- Fill/bleed the brake system.
- **[R/RT]** To bleed, detach the brake caliper and position it with the bleed nipple at the highest point.

### **Caution:**

Renew sealing rings for brake line. Do not damage brake pads.

**[ABS]** Check sensor gap and adjust if necessary with spacing plate.

**Sensor gap:**... 0,45...0,55 mm ( 0.0177...0.02165in)

### **Tightening torque:**

Brake caliper to rear wheel drive ..... 40 Nm  
 Brake line to brake caliper..... 15 Nm  
 Bleed screw at brake caliper

**[RS]** ..... 7 Nm  
**[GS/R/RT]** ..... 4 Nm



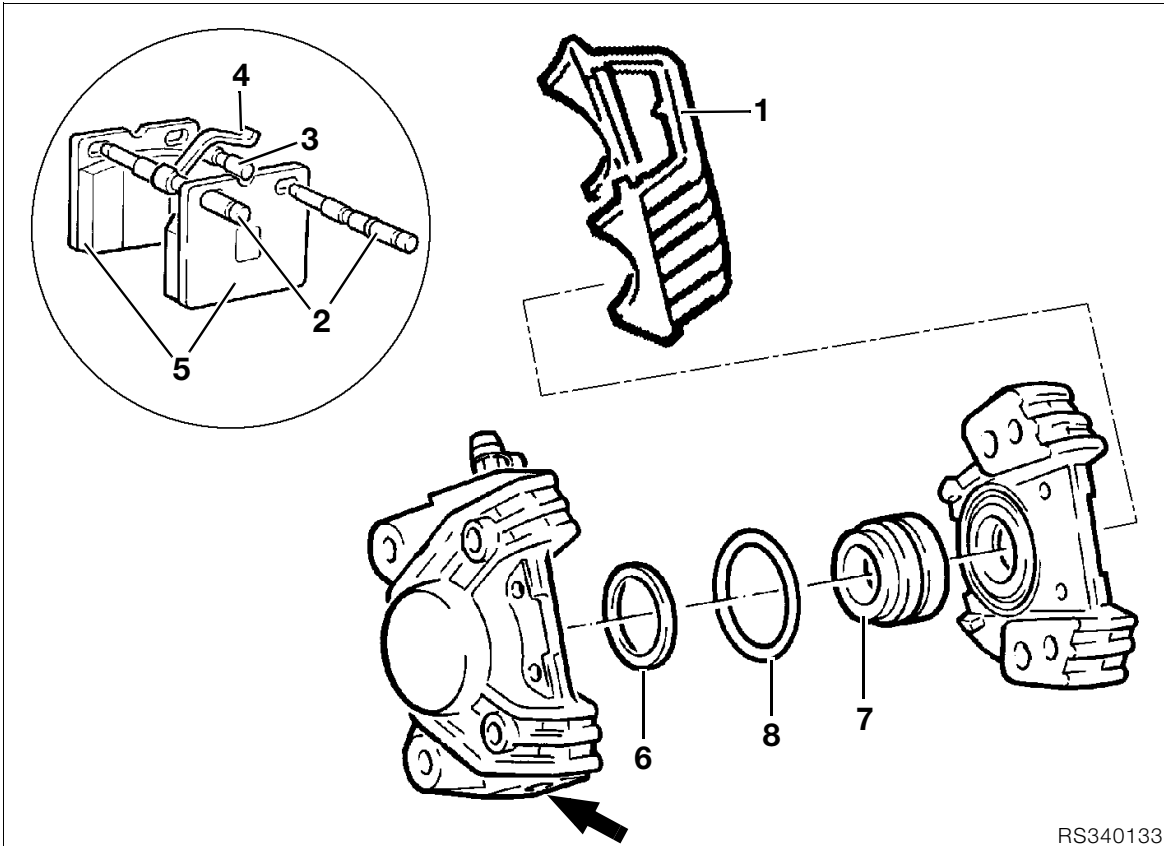

RS340133

## [RS] Dismantling and assembling rear brake caliper

### Dismantling rear brake caliper



#### Caution:

The two halves of the brake caliper **must not be unscrewed!**

- Remove protective cap (1).
- Drive out retaining pins (2) from the wheel side.
- Take out clamping pin/curved spring (3/4).
- Take out brake pads (5).
- Take out dust protection sleeve (6) at left/right.
- Seal the bleed screw.



#### Tightening torque:

Bleed screw at brake caliper ..... 7 Nm

- Hold a cloth over the brake caliper.
- **Carefully** press our brake piston (7) with a compressed air gun at the connecting bore, working at low air pressure.



#### Caution:

Do not allow your fingers to be trapped by the piston; risk of injury!

- Remove sealing ring (8) from the left/right wheel brake cylinders.
- Inspect the brake caliper piston for hairline cracks/score-marks/other damage.

## Assembling rear brake caliper

- Coat new sealing rings (8) with brake fluid and insert them into the left/right brake cylinders.
- Coat both brake caliper pistons (7) with brake fluid and install them.



### Caution:

Do not tilt the brake pistons when assembling.

- Insert the dust protection sleeve (6) at left and right

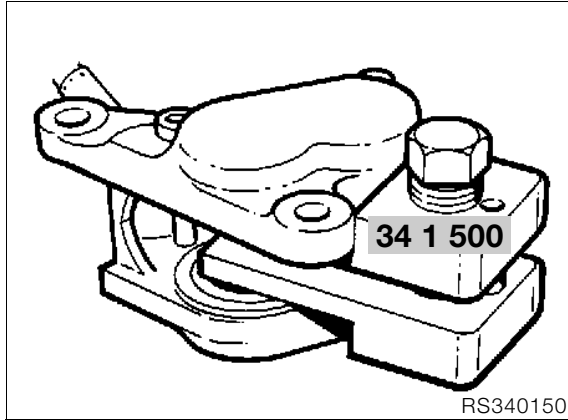

- Before installing the new brake pads, press the pistons back into the brake calipers with the resetting device, **BMW No. 34 1 500**.

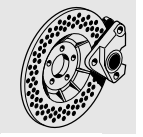

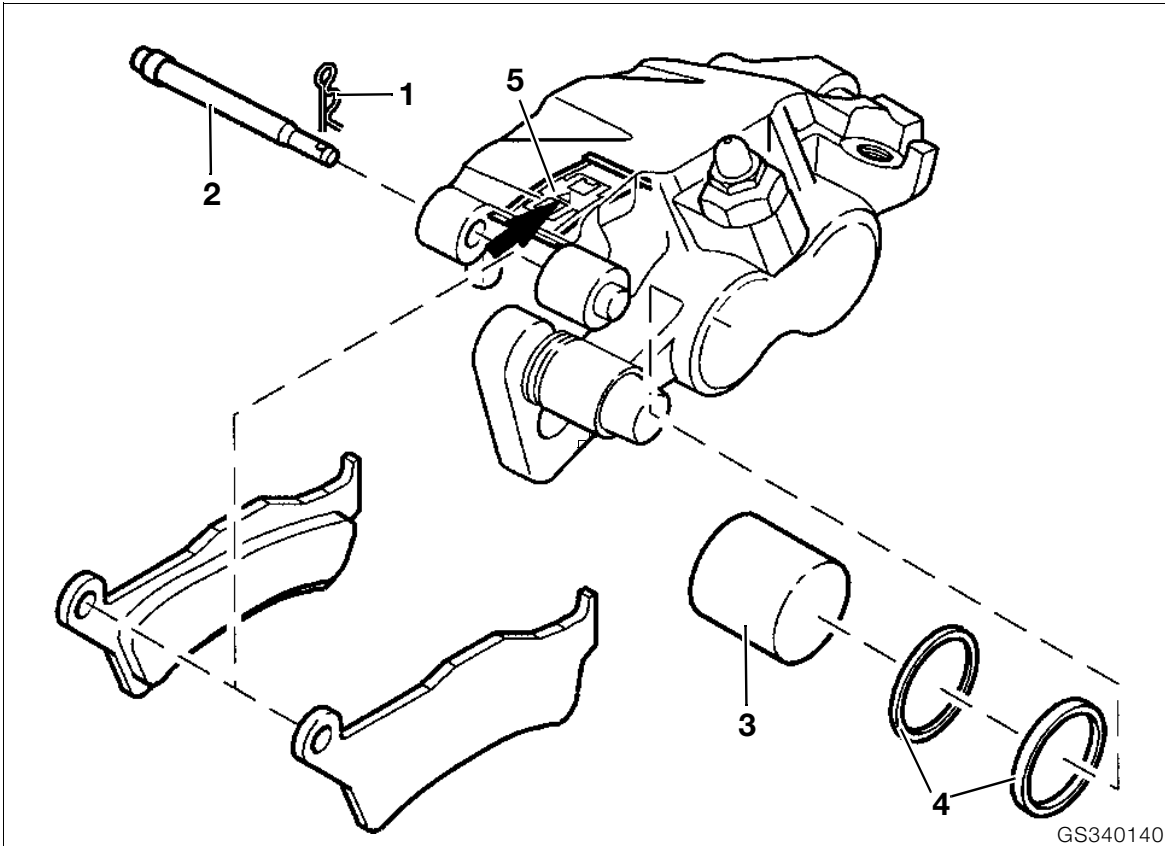

## [GS/R/RT] Dismantling and re-assembling rear brake caliper

### Dismantling rear brake caliper

- Remove keeper (1).
- Drive out retaining pin (2).
- Take out brake pads.
- Seal the bleed screw.



#### ! Tightening torque:

Bleed screw at brake caliper ..... 4 Nm

- Hold a cloth over the brake caliper piston.
- **Carefully** press out brake piston (3) with a compressed air gun applied to the connecting bore; work at low air pressure



#### ! Caution:

Keep fingers away from gap between pistons and side contact face of brake pads; risk of injury.

- Remove sealing rings (4) from left/right cylinder.
- Inspect the brake caliper piston for hairline cracks/score-marks/other damage.

### Assembling rear brake caliper

- Coat the new sealing rings with brake fluid and insert them into the left/right brake caliper cylinders.
- Coat both brake caliper pistons with brake fluid and install them.



#### ! Caution:

Do not tilt the brake pistons when installing.

- Coat the adapter plate locating pins with **Shell Retinax A** and install the adapter plate.
- Insert locating plate (5) into brake caliper.



#### Note:

The installed position must be correct (arrow pointing in forward-travel direction).

- Insert brake pads and secure with retainers.

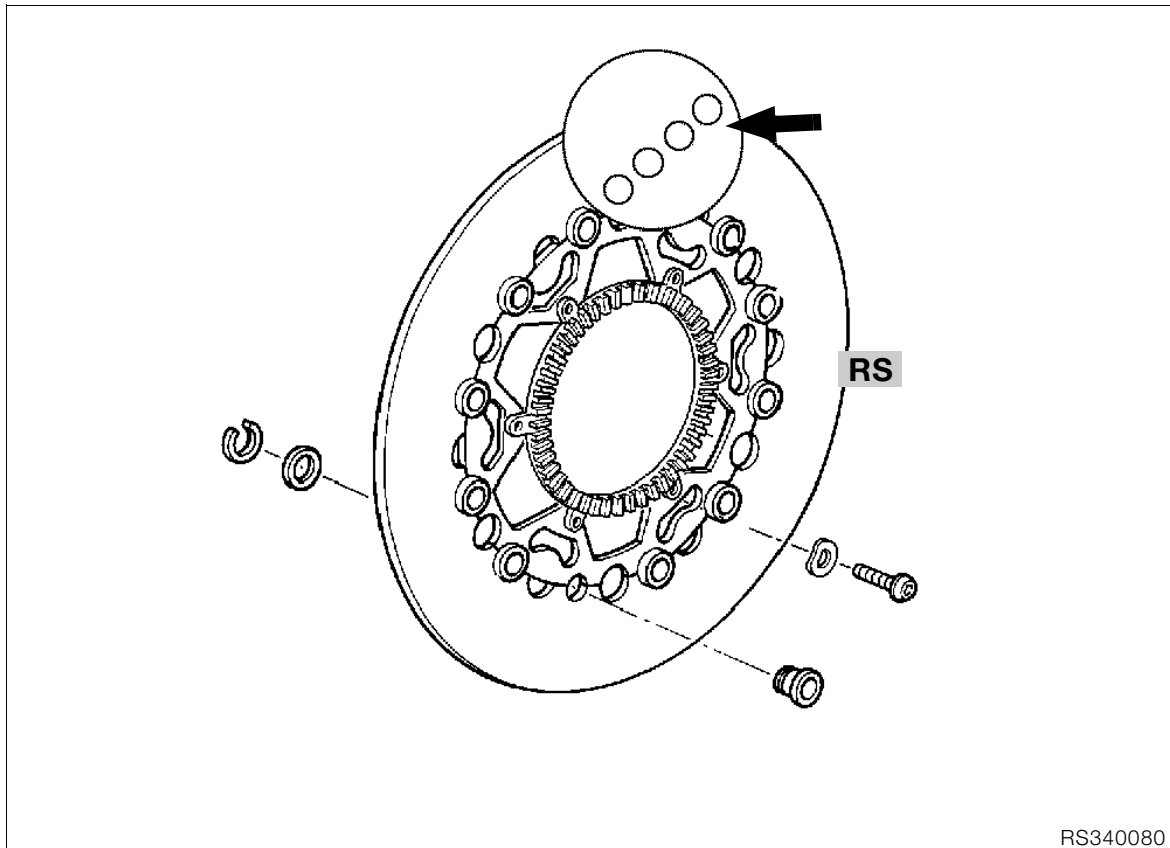

## Removing and installing front brake disc

- Remove front wheel.
- Remove/install brake disc.
- Degrease brake discs before installing.



### Note:

Installed direction (arrow) of brake discs must be correct.



### Tightening torque:

Brake disc to front wheel

**[RS/RT]** ..... 21 Nm

**[GS]** (clean thread + Loctite 243)..... 24 Nm

**[R]** Cast alloy front wheel ..... 21 Nm

**(R)** Spoked front wheel

(clean thread + Loctite 243)..... 24 Nm



### Caution:

Check/adjust sensor gap; if exchanged, apply a new sensor gap measuring mark.

**Sensor gap:**.. 0.45...0.55 mm (0.0177...0.02165 in)

**[RS] Removing and installing rear brake disc (attached to rear wheel drive)**

- Remove the brake caliper.
- Remove rear wheel.

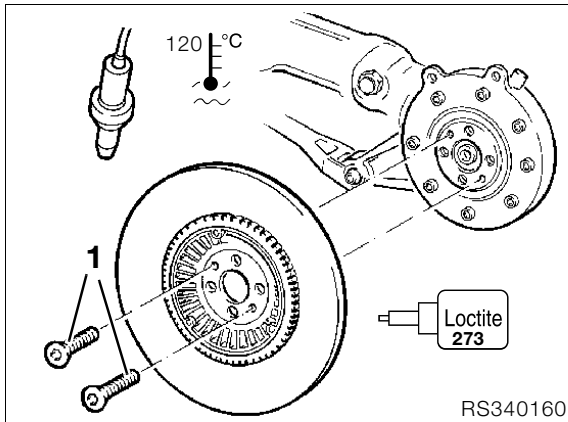

- Heat brake disc retaining screws (1) to 120 °C/ remove.



**Note:**

Mark the installed position of the brake disc, so that vertical runout of the sensor wheel does not change.

- Install in the reverse order of work.
- Degrease the brake disc before installing.



**Caution:**

**[ABS]** Check sensor gap and adjust with spacing plates if necessary.

**[ABS]** If the brake disc and therefore the sensor wheel are renewed, the disc's vertical runout must be determined/marked.

**Sensor gap:**.. 0.45...0.55 mm (0.0177...0.02165 in)



**Tightening torque:**

Brake disc to rear wheel drive  
(clean thread + Loctite 273)..... 21 Nm

**[GS/R] Removing and installing rear brake disc (attached to rear wheel hub)**

- Remove the brake caliper.
- Remove rear wheel.

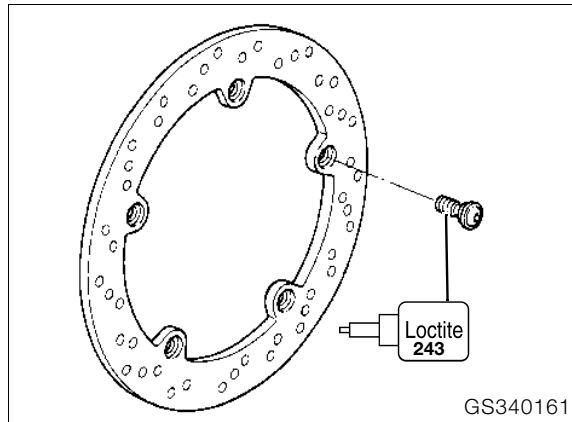

- Remove brake disc.
- Install in the reverse order of work.
- Degrease the brake disc before installing.



**Caution:**

**[ABS]** Check sensor gap and adjust with spacing plates if necessary.

**Sensor gap:**.. 0.45...0.55 mm (0.0177...0.02165 in)



**Tightening torque:**

Brake disc to rear wheel drive  
(clean thread + Loctite 243)..... 21 Nm

## [RT/R] Removing and installing rear brake disc (attached to rear wheel drive)

- Remove the brake caliper.
- Remove rear wheel.

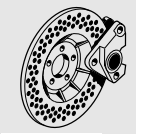
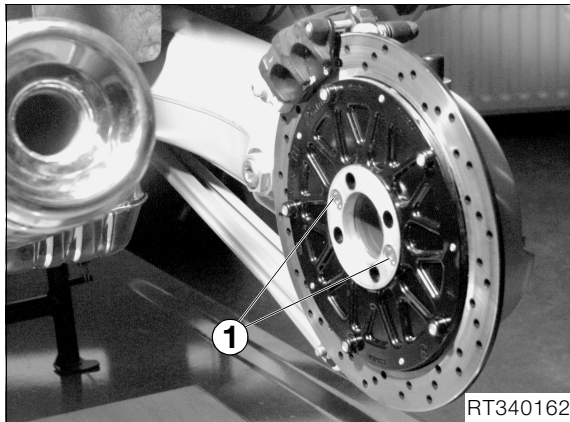

- Heat the brake disc retaining screws (1) to 120 °C/remove.



### Note:

Mark installed position of brake disc, so that lateral runout of sensor wheel is not changed.

- Install in the reverse order of work.
- Degrease the brake disc before installing.



### Caution:

**[ABS]** Check sensor gap and adjust with spacing plates if necessary.

**[ABS]** If the brake disc and therefore the sensor wheel are renewed, the disc's lateral runout must be determined/marked.

**Sensor gap:**.. 0.45...0.55 mm (0.0177...0.02165 in)



### Tightening torque:

Brake disc to rear wheel drive  
(clean thread + Loctite 273)..... 21 Nm

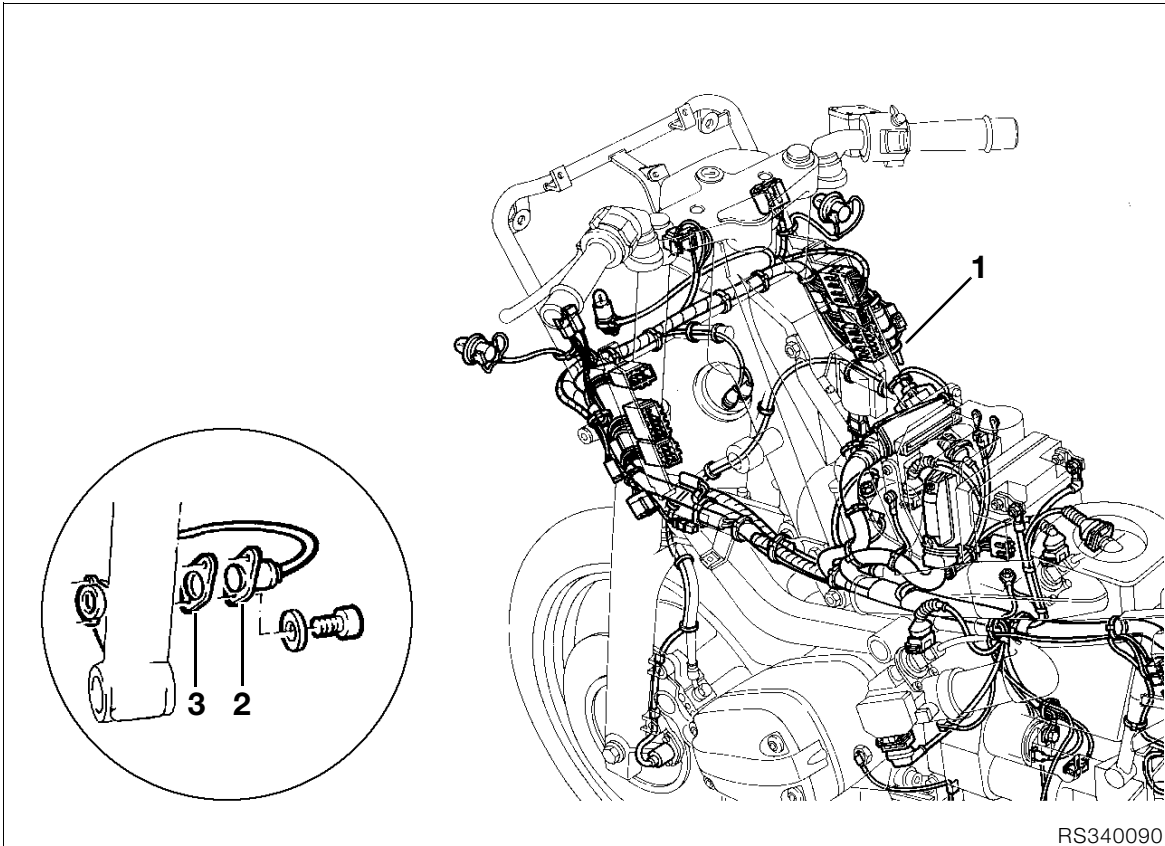

RS340090

## [RS] Removing and installing front ABS sensor

- Remove the right side section of the fairing.
- Remove front mudguard.
- Separate plug connector (1) in sensor line.
- Remove sensor (2) with **Torx T 25**.
- Install in the reverse order of work.



### Caution:

Run the sensor line correctly.  
Check sensor gap and adjust if necessary with spacer plate (3).

**Sensor gap:**... 0.45...0.55 mm (0.0177...0.02165 in)



### Tightening torque:

Sensor .....handtight, 4 Nm

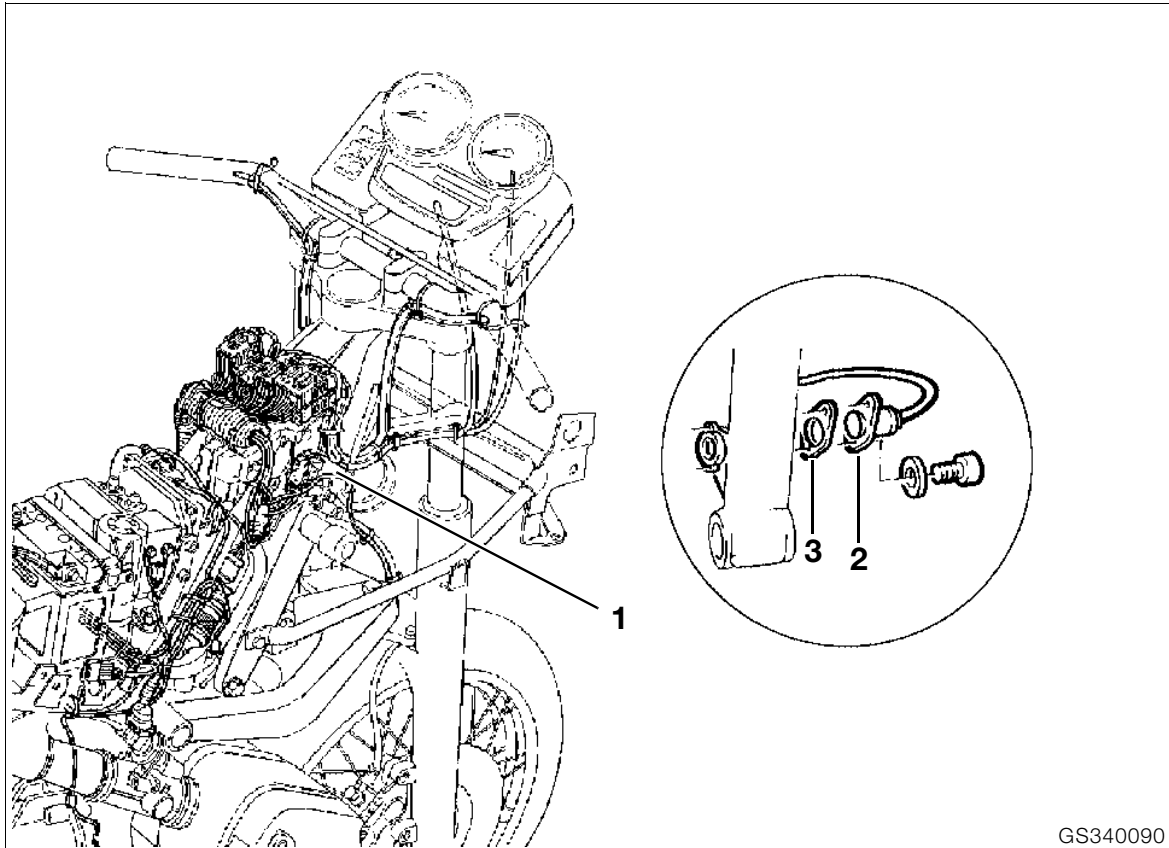

GS340090

## [GS/R] Removing and installing front ABS sensor

- [GS] Remove front wheel.
- [GS] Remove front mudguard.
- Remove fuel tank.
- Separate plug connector (1) in sensor line.
- Remove sensor (2) with **Torx T 25**.
- Install in the reverse order of work.



### Caution:

Run the sensor line correctly.  
Check sensor gap and adjust if necessary with spacer plate (3)..

**Sensor gap:**.. 0.45...0.55 mm (0.0177...0.02165 in)



### Tightening torque:

Sensor .....handtight, 4 Nm



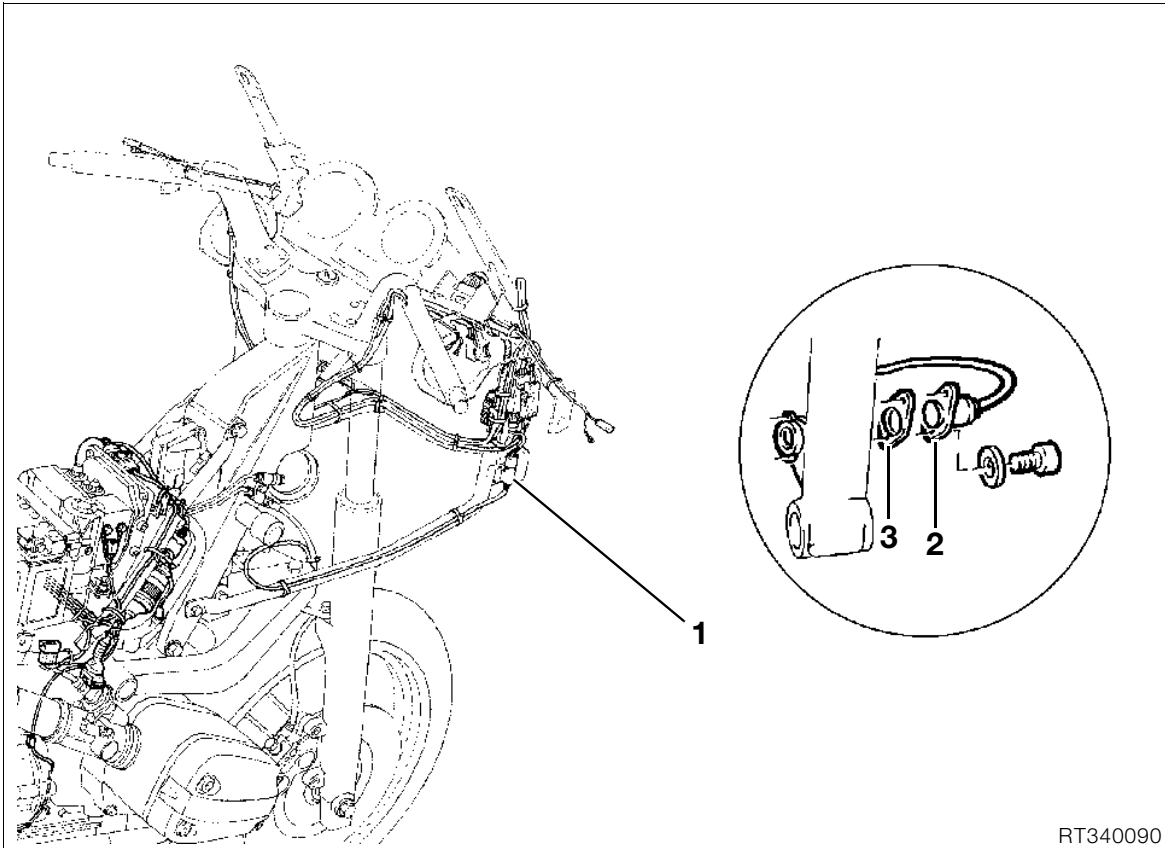

RT340090

### [RT] Removing and installing front ABS sensor

- Remove right side sections of fairing.
- Remove front mudguard.
- Separate plug connector (1) in sensor line.
- Remove sensor (2) with **Torx T 25**.
- Install in the reverse order of work.



**Caution:**

Run the sensor line correctly.  
Check sensor gap and adjust if necessary with spacer plate (3).

**Sensor gap:**... 0.45...0.55 mm (0.0177...0.02165 in)



**Tightening torque:**

Sensor .....handtight, 4 Nm

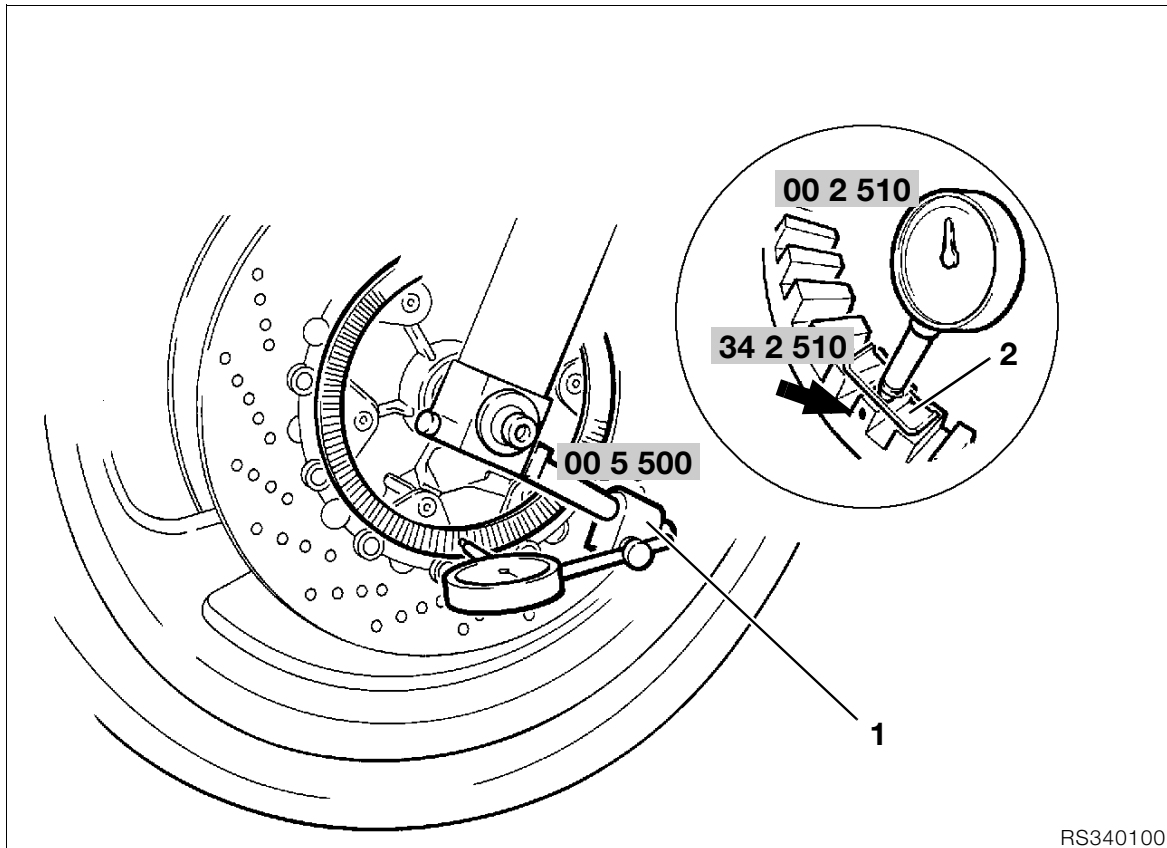

RS340100

## [ABS] Adjusting front sensor gap

### Marking sensor wheel

- Take load off front wheel/lift clear of ground.
- Attach dial gauge holder (1), **BMW No. 00 2 500**, with dial gauge, **BMW No. 00 2 510** and measuring shoe (2), **BMW No. 34 2 510**, to fork slider tube.
- Zero the dial gauge.
- Measure axial runout over the entire circumference.
- Using a paint pencil, make a permanent mark at the point where the sensor is farthest away from the sensor wheel (arrow).



### Caution:

If parts are replaced (brake disc etc.) and a used or previously marked sensor wheel is installed, the sensor ring must be measured and marked again. Remove the old marking.

### Checking and adjusting sensor gap

- Check/adjust at the marked point.
- If necessary, remove/install sensor with **Torx T 25** and adjust sensor gap with spacing plates.

**Sensor gap:**.. 0.45...0.55 mm (0.0177...0.02165 in)



### Caution:

After adjusting, check that the sensor wheel is free to turn at all points on its circumference.

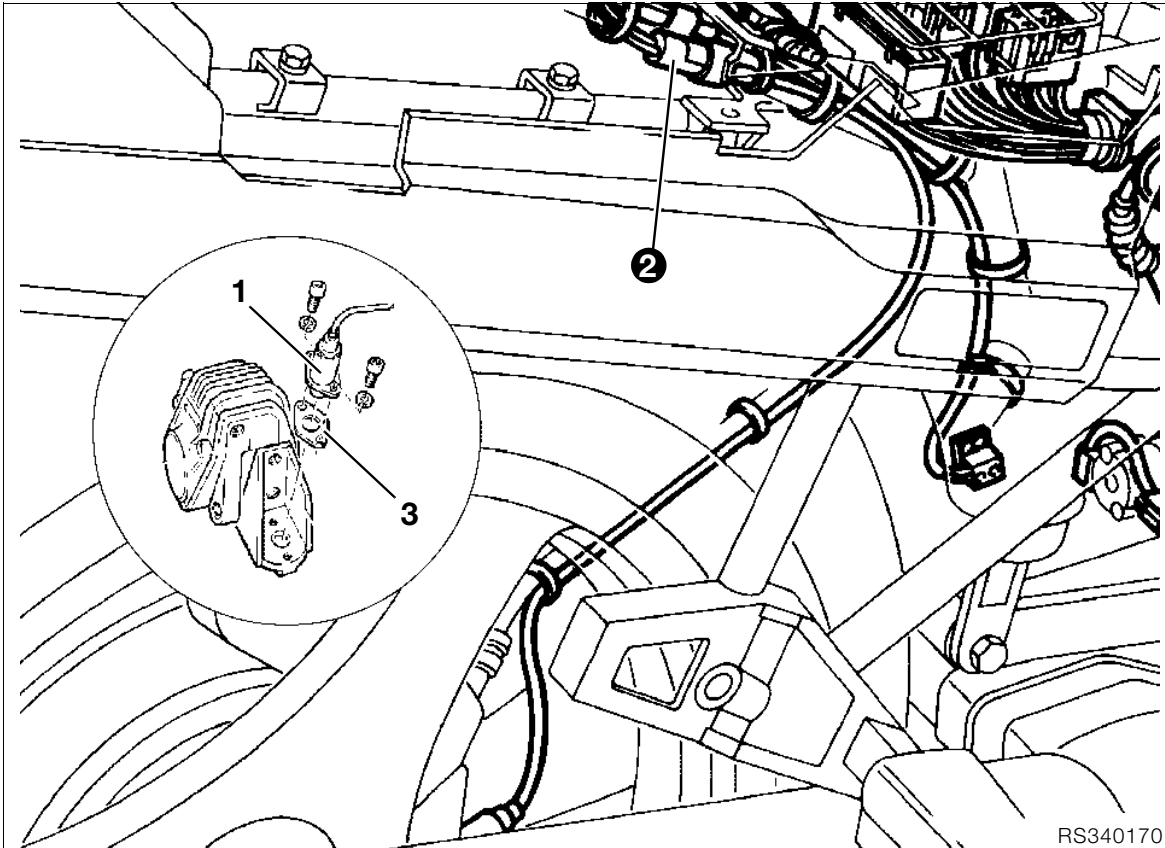

### [RS] Removing and installing rear ABS sensor

- Remove brake caliper but do not detach brake line.
- Using **Torx T 25**, detach sensor (1).
- Separate the plug connector (2) in the sensor line.
- Install in the reverse order of work.



**Caution:**

Check sensor gap and adjust if necessary with spacer plates (3).  
Run the sensor line correctly.

**Sensor gap:**... 0.45...0.55 mm (0.0177...0.02165 in)



**Tightening torque:**

Sensor .....handtight, 4 Nm

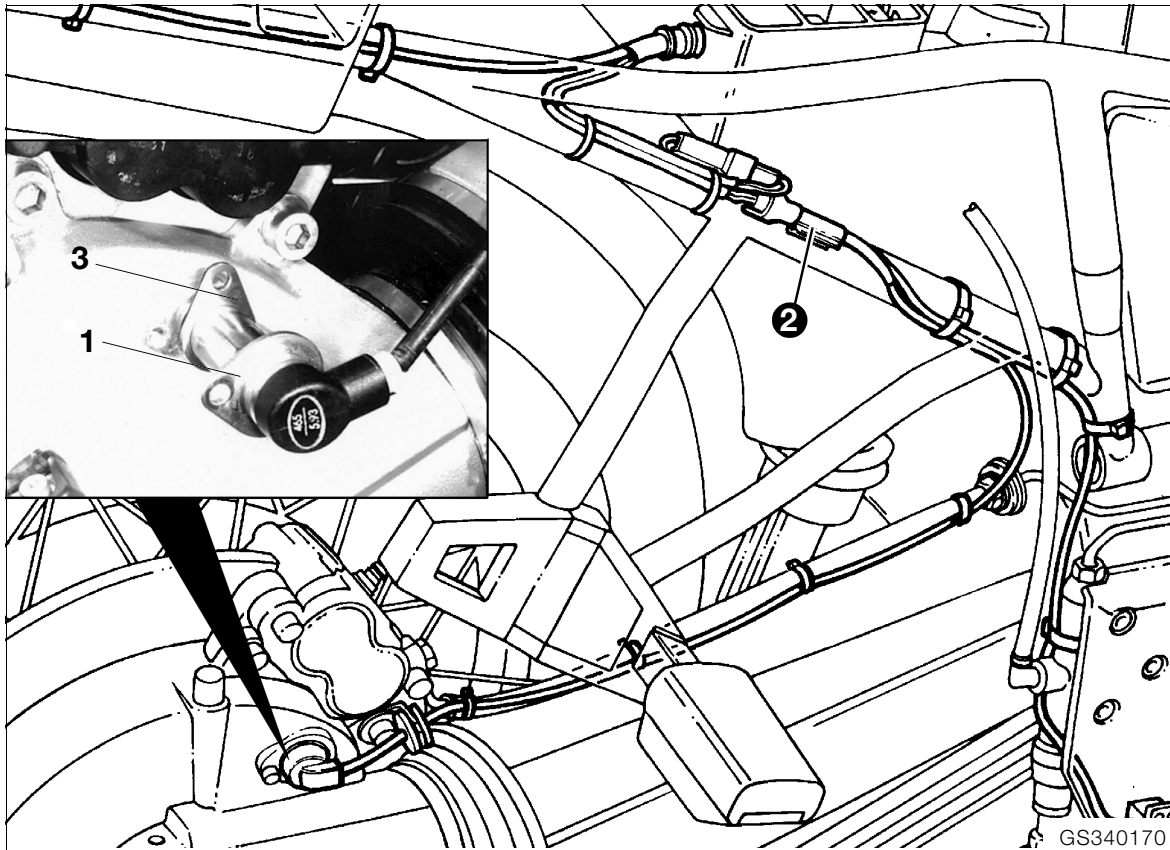

**[GS/R/RT] Removing and installing rear ABS sensor**

- **[RT]** Remove small right side section of fairing.
- Before removing/installing, clean the sensor bore.
- Detach sensor (1) with **Torx T 25**.
- Separate plug connector (2) in the sensor line.
- Install in the reverse order of work.
- Coat O-rings with oil before installing



**Caution:**

Run the sensor line correctly.  
 Check sensor gap and adjust if necessary with spacer plates (3).

**Sensor gap:**.. 0.45...0.55 mm (0.0177...0.02165 in)



**Tightening torque:**

Sensor .....handtight, 4 Nm

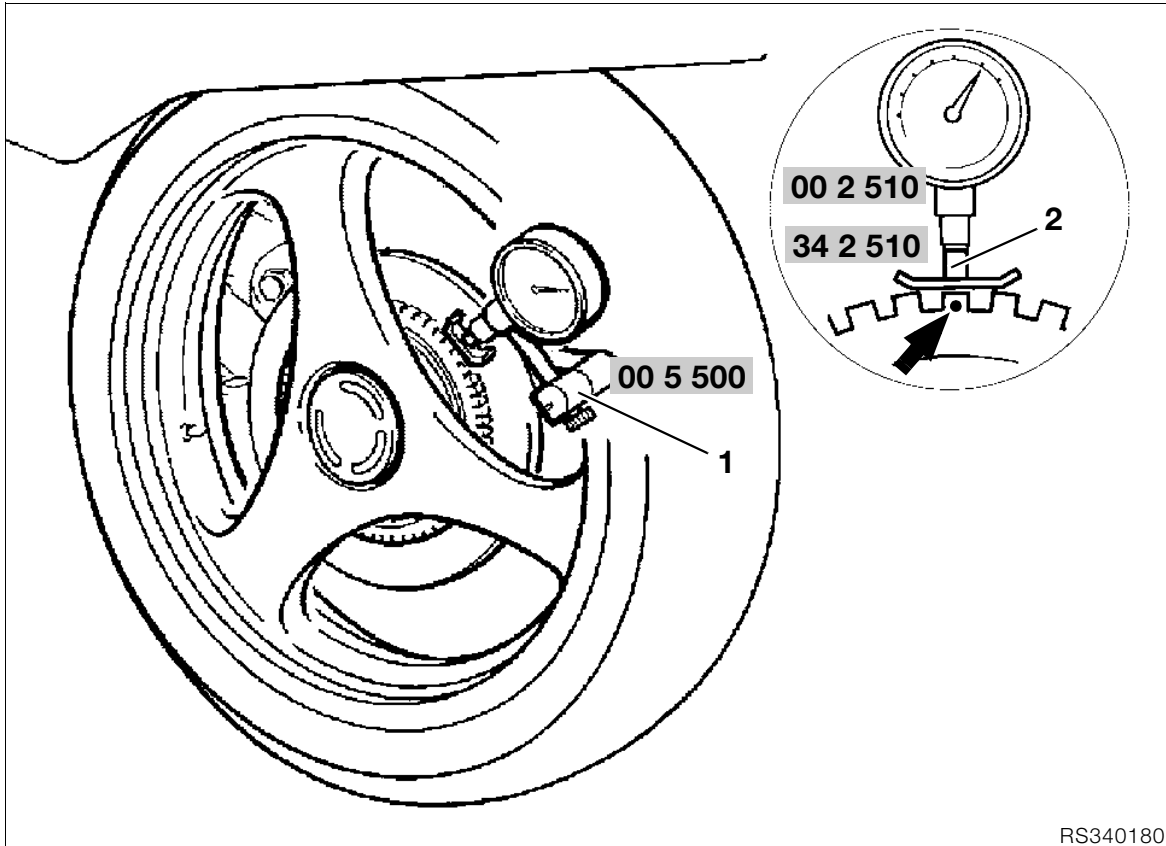

RS340180

## [RS] Adjusting rear ABS sensor gap

## Checking and adjusting sensor gap

### Marking sensor wheel

- Remove the brake caliper.
- Remove rear wheel.
- Fasten measuring adapter, **BMW No. 36 4 600**, with a M 8 x 60 mm bolt to the brake caliper mount.
- Attach dial gauge holder (1), **BMW No. 00 2 500**, with dial gauge, **BMW No. 00 2 510** and measuring shoe (2), **BMW No. 34 2 510**.
- Zero the dial gauge.
- Measure radial runout over the entire circumference.
- Make a permanent paint pencil mark at the point where the sensor wheel is farthest away from the sensor (arrow).

- Check/adjust at the marked point
- In necessary, remove/install sensor with **Torx T 25** and adjust sensor gap with spacing plates.

### ⚠ Caution:

After adjusting, check that the sensor wheel is free to turn at all points on its circumference.

**Sensor gap:**.. 0.45...0.55 mm (0.0177...0.02165 in)

### 🔧 Tightening torque:

Sensor .....handtight, 4 Nm

### ⚠ Caution:

If parts are replaced (brake disc etc.) and a used or previously marked sensor wheel is installed, the sensor ring must be measured and marked again. Remove the old marking.

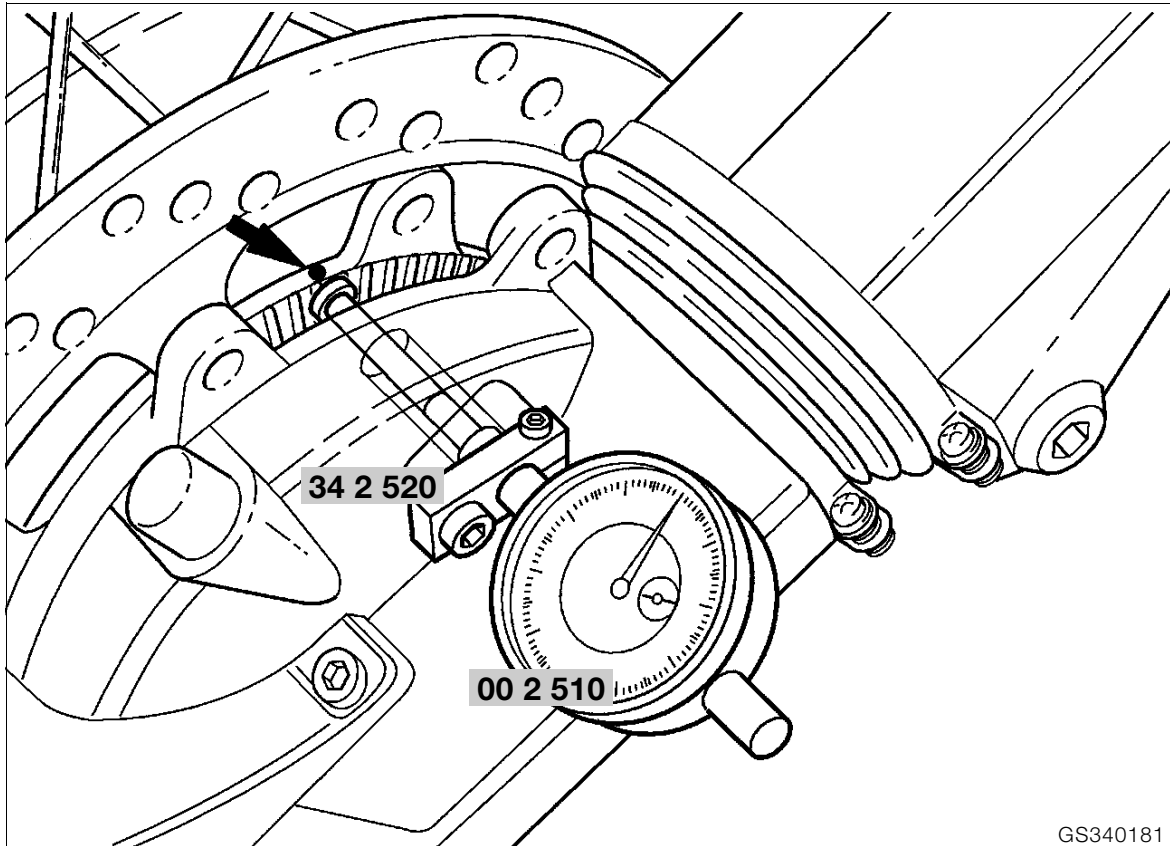

GS340181

## [GS/R/RT] Adjusting rear ABS sensor gap

### Marking sensor wheel

- Before removing/installing, clean sensor and bore.
- Using **Torx T 25**, detach the sensor.
- Bolt dial gauge holder with measuring shoe, extension **BMW No. 34 2 520** and dial gauge, **BMW No. 00 2 510**, to sensor mount.
- Zero the dial gauge.
- Measure axial runout over the entire circumference.
- Make a permanent paint pencil mark at the point where the sensor wheel is farthest away from the sensor (arrow).

### **Caution:**

If parts are replaced (rear wheel etc.) and a used or previously marked sensor wheel is installed, the sensor ring must be measured and marked again. Remove the old marking.

### Checking and adjusting sensor gap

- Check/adjust at the marked point
- If necessary, remove/install sensor with **Torx T 25** and adjust sensor gap with spacing plates.

### **Caution:**

After adjusting, check that the sensor wheel is free to turn at all points on its circumference.

**Sensor gap:**.. 0.45...0.55 mm (0.0177...0.02165 in)

### **Tightening torque:**

Sensor .....handtight, 4 Nm

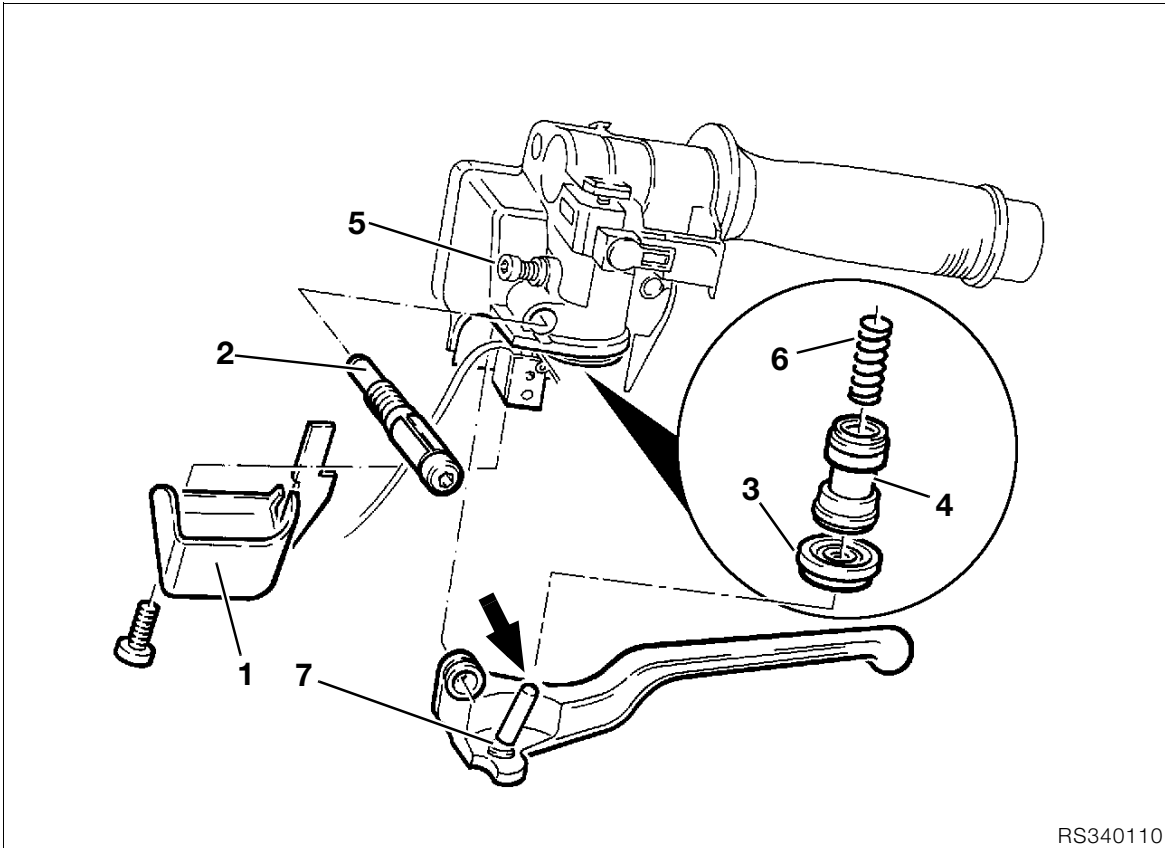

RS340110

### Removing, installing, dismantling and assembling front brake master cylinder

- Drain fluid from brake system.

#### **Caution:**

Do not allow brake fluid to come into contact with painted parts of the motorcycle, because brake fluid destroys paint.

- Remove cover (1).
- Remove handbrake lever pivot pin (2).
- Pull off dust protection sleeve (3).
- Press piston (4) in slightly.
- Slacken off stop screw (5).

#### **Caution:**

Piston (4) is spring-loaded.

- Take out piston (4) with spring (6).
- Install in the reverse order of work.
- Coat pistons and sleeves with brake fluid before installing.

#### **Caution:**

Sealing lips of sleeves face the pressure chamber.

- Fill/bleed the brake system.

### Adjusting specification for handbrake lever

- Clean grub screw (7), coat it with **Loctite 270** and screw it in until there is no play at the handlebar lever; then tighten it further by precisely **one half-turn**.

#### **Caution:**

Never tighten the grub screw by more than this additional half-turn, or else the brake could fail or be locked on.

- Seal grub screw (7) with paint.
- Grease thrust pin (arrow) at handlebar lever lightly with **Shell Retinax A**.

#### **Note:**

The pivot pin is secured with **Tuflok blue**. Threads secured with this material can be unscrewed and retightened several times.

#### **Tightening torque:**

Pivot pin (2) ..... 8 Nm  
(Threads secured with Tuflok blue can be unscrewed and tightened several times.)

## Removing and installing rear brake master cylinder

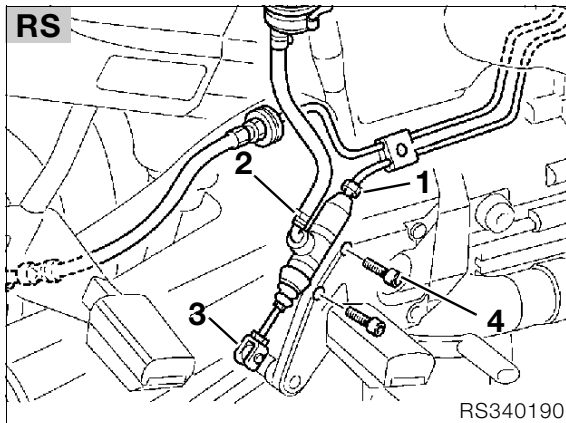

- Drain fluid from brake system.

### **Caution:**

Do not allow brake fluid to come into contact with painted parts of the motorcycle, because brake fluid destroys paint.

- **[RS/GS/R]** Detach brake line (1) and hose (2).
- **[RS/GS/R]** Release pin (3).
- **[RS/GS/R]** Detach brake master cylinder (4).
- **[RT]** Remove right side sections of fairing.
- **[RT]** Detach brake line (1).
- **[RT]** Release pin (3).
- **[RT]** Detach brake master cylinder (4).
- **[RT]** Remove brake fluid reservoir with hose (2) and master cylinder.
- **[RT]** Detach hose (2) from master cylinder.
- Install in the reverse order of work.
- Tighten non-reusable hose clip (2) with pliers, **BMW No. 13 1 500**.

### **Caution:**

Bleed the brake system carefully.  
Check/adjust piston rod snifting-action play.



### **Tightening torque:**

Master cylinder to footrest plate ..... 9 Nm

## Checking and adjusting relief clearance of piston rod

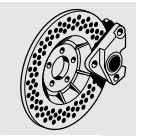
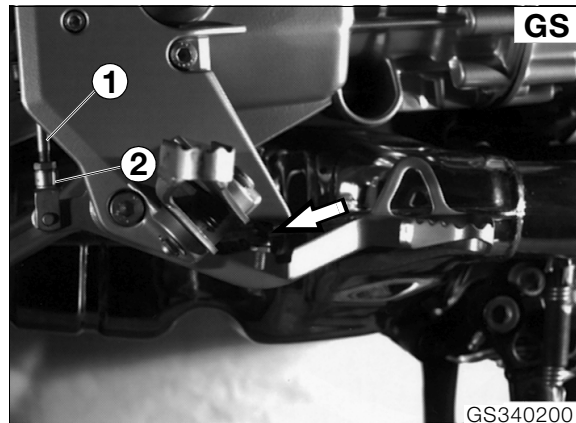

- Insert a feeler gauge of the correct thickness between the adjusting screw/brake lever and the stop (arrow).

**Feeler gauge thickness:** ..... 0.2 mm (0.00787 in)

- Release locknut (1).
- Insert piston rod (2), turning to right until clearance is present.
- Turn the piston rod carefully to the left to withdraw it again until no clearance is present; lock it in this position.
- Tighten locknut/check clearance again.



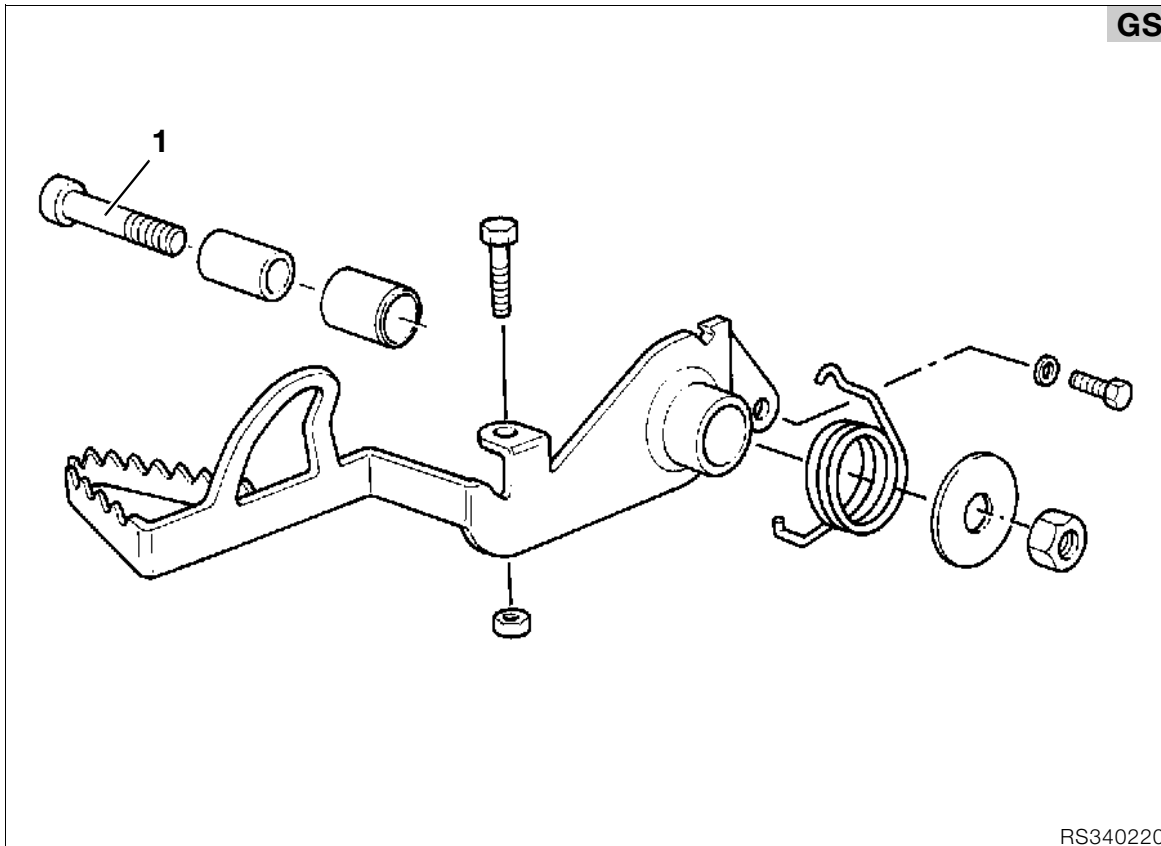

RS340220

## Removing and installing brake pedal

- Release pin on brake linkage.
- Remove brake pedal retaining pin (1).
- Remove brake pedal with spiral spring.
- Install in the reverse order of work.
- Lubricate pivot bushing with **Shell Retinax A**.



### Caution:

Check/adjust piston rod relief clearance.  
See removal and installation of brake master cylinder.  
The brake light must come on as soon as the rear brake begins to take effect.



### Tightening torque:

Brake pedal to footrest plate  
(free from grease)..... 37 Nm

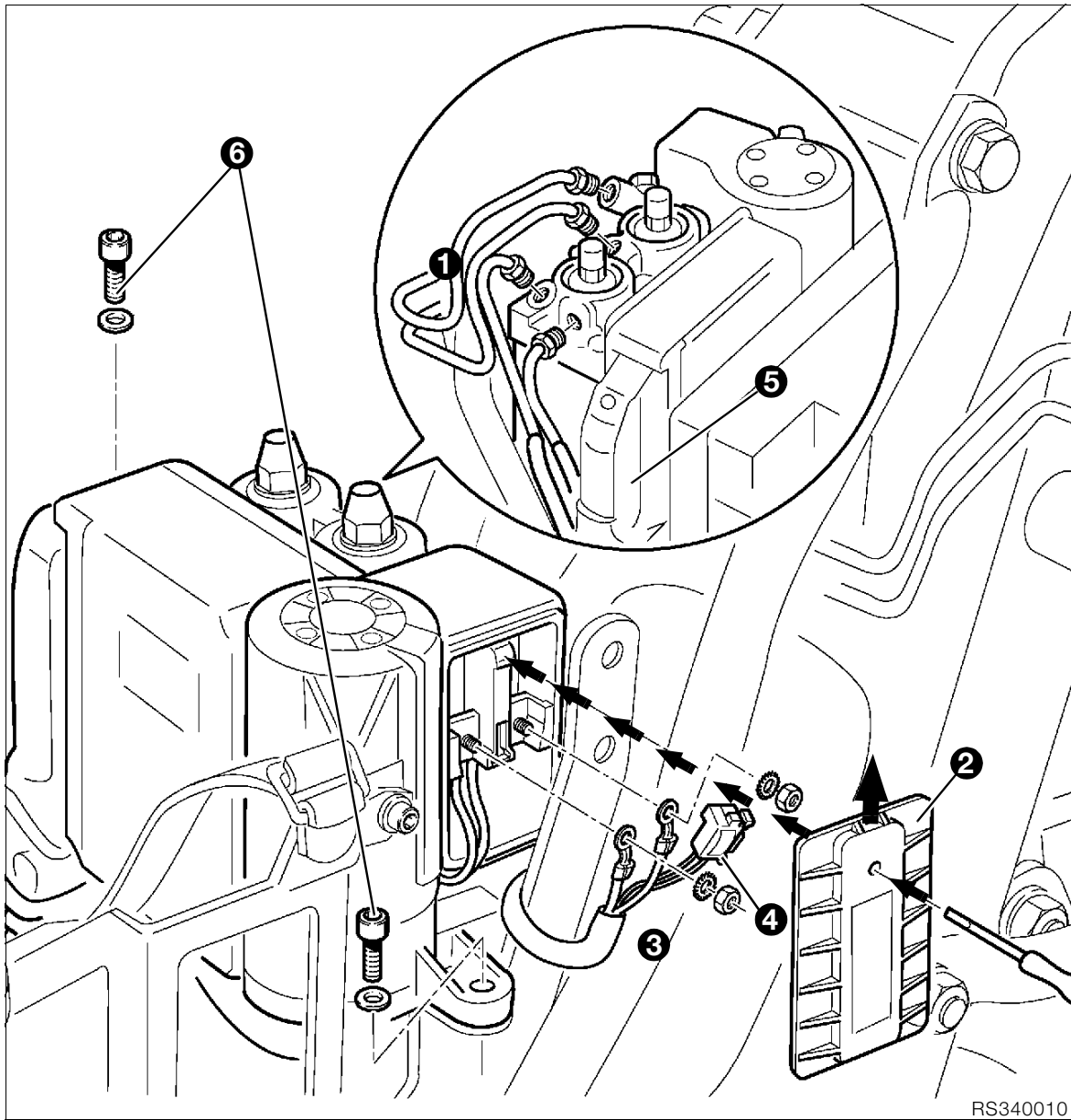

## Removing and installing ABS unit



### Caution:

Work on the ABS unit is only to be performed by an authorized BMW workshop.

## Removing the ABS unit

- Remove fuel tank.
- Disconnect ABS brake lines (1) at ABS unit



### Caution:

If brake fluid escapes, it may damage paint. Line connections **must be** protected against dirt penetration; if necessary seal/cover over.



- Hold the front brake lever against the handlebar grip with a rubber band (to close the brake fluid feed bore).



### Caution:

Switch off ignition, disconnect and insulate the ground (earth) strap.

- Remove cover (2) from ABS control unit, press the lock in with a screwdriver and pull the cover up.
- Detach wires (3).
- Pull off 2-pin plug (4).
- Pull off the central plug (5).
- Remove the ABS unit (6).

## Installing the ABS unit

- Install the ABS unit (6).
- Connect the central plug (5).



### Caution:

Make sure the cable is not at an angle, or its insulation may be damaged.

- Reconnect the 2-pin plug in the correct position, pushing the two halves fully together, and press the two wires into the center (smaller) cable entries.
- Push the two plugs for the connecting cable/wiring harness onto the threaded pins with the crimp at the front.
- Press the two cables into the remaining free cable entries.
- Tighten the nuts.



### Caution:

Always use new self-locking nuts.



### Tightening torque:

Battery -/M5 ..... 3.5 Nm  
Battery +/M4 ..... 3 Nm

- Install a new cover.



### Caution:

When sliding the cover on, make sure that all cables are correctly located in their cable entries. **Discard** the old cover.

- Screw ABS brake lines (1) to ABS unit.
- Fill/bleed the brake system.
- Install the fuel tank.



### Tightening torque:

ABS unit to holder  
M6 screw ..... 9 Nm  
M6 screw (Torx) ..... 5 Nm  
Brake line to ABS unit ..... 15 Nm  
Bleed screw at ABS unit ..... 9 Nm

## Removing and installing ABS relay and relay base

### Removing ABS relay

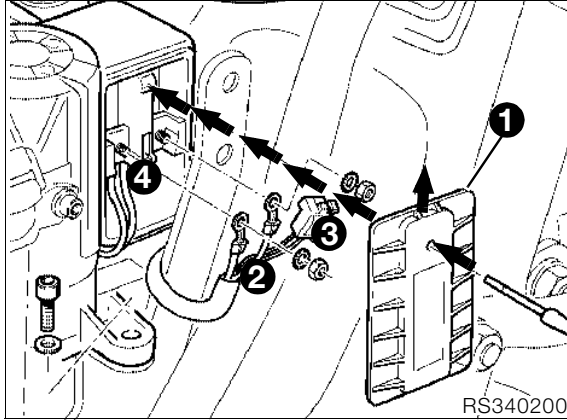

#### **Caution:**

Switch off ignition, disconnect and insulate the ground (earth) strap.

- Remove cover (1) from ABS control unit, press in the lock with a screwdriver and pull the cover up.
- **Discard** the old cover (1).
- Detach lines (2) and **discard** nuts.

#### **Caution:**

Make sure the cable is not at an angle or its insulation may be damaged.

- Pull off 2-pin plug (3).
- Take out relay base (4).
- **Slacken off** screws on relay base by app. 2 turns with **Torx T20**.
- Pull the relay off upwards.

### Installing the ABS relay

- Insert the ABS relay with the FAG inscription facing the detent hook.
- Tighten the screws at the relay base.
- Push the relay base into the relay housing, at the same time pressing both engine cables into the left cable entries on the relay housing (red at bottom, black at top).
- Attach black engine cable to left threaded pin (M5) with crimp at back.



#### **Caution:**

Make sure the cable is not at an angle, or its insulation may be damaged.

- Attach 2-pin plug in correct position, pushing it on fully and press the two wires into the center (smaller) cable entries.
- Push the two plugs for the connecting cable/wiring harness onto the threaded pins with the crimp at the front..
- Press the two cables into the remaining free cable entries.
- Tighten the nuts.



#### **Caution:**

Always use new selflocking nuts.

- Install a new cover (1).



#### **Caution:**

When sliding the cover on, make sure that all cables are correctly located in their cable entries. **Scrap** the old cover.

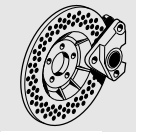

## Removing ABS relay base



### Caution:

Switch off ignition, disconnect and insulate the ground (earth) strap.



- Remove cover (1) from ABS control unit, press in the lock with a screwdriver and pull the cover out upwards.
- **Scrap** the old cover (1).
- Detach the wires (2); **scrap** the nuts.



### Caution:

Make sure the cable is not at an angle, or its insulation may be damaged.

- Pull off the 2-pin plug (3).
- Take out relay base (4).
- Remove screws at relay base with **Torx T20**.
- Remove the ABS relay.
- Press the contact interlock out of the relay base.
- Working from the relay side, release the plug with special tool **Art. No. 50000-017-507 from the Grote und Hartmann company**.



### Caution:

The contact has a double detent. When pulling the plug out of the relay base, avoid applying too much tension to the cable. If the cable breaks, the complete ABS unit will have to be exchanged.

## Installing the ABS relay base

- Bend up the contact interlock on the plug.
- Insert the contact into the relay base.



### Caution:

The contact must be heard to engage and must be firmly located.

- Insert the ABS relay with the FAG inscription facing the detent hook.
- Insert a Torx screw into the ring shoe of the red engine cable.



### Note:

The crimp side is towards the screw head.

**Caution:**

The same Torx screws must be re-used because of their self-locking effect.

When inserting the screws again, make sure that they pick up with the existing thread in the sheet-metal element.

Failing this, vibration could cause the screws to work loose.

---

- Place the ring show (with two cables) on the bore of the insert at the rear of the relay base, with the crimp side towards the relay base, and screw on together the red engine cable, using the Torx screw.
- Use the second Torx screw to secure the flat plug to the relay.
- Press the contact interlock into the relay base at the side.
- Push the relay base into the relay housing, at the same time pressing both engine cables into the left cable entries on the relay housing (red at bottom, black at top).
- Attach black engine cable to left threaded pin (M5) with crimp at back.

**Caution:**

Make sure the cable is not at an angle or its insulation may be damaged.

---

- Push the 2-pin plug fully on in the correct position and press the two wires into the center (smaller) cable entries.
- Push the two plugs for the connecting cable/wiring harness onto the threaded pins with the crimp at the front.
- Press the two cables into the remaining free cable entries.
- Tighten the nuts.

**Caution:**

Always use new self-locking nuts.

---

- Install a new cover (1).

**Caution:**

When sliding the cover on, make sure that all cables are correctly located in their cable entries.

---

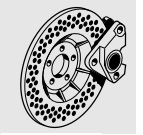

## Removing and installing brake line (with ABS)

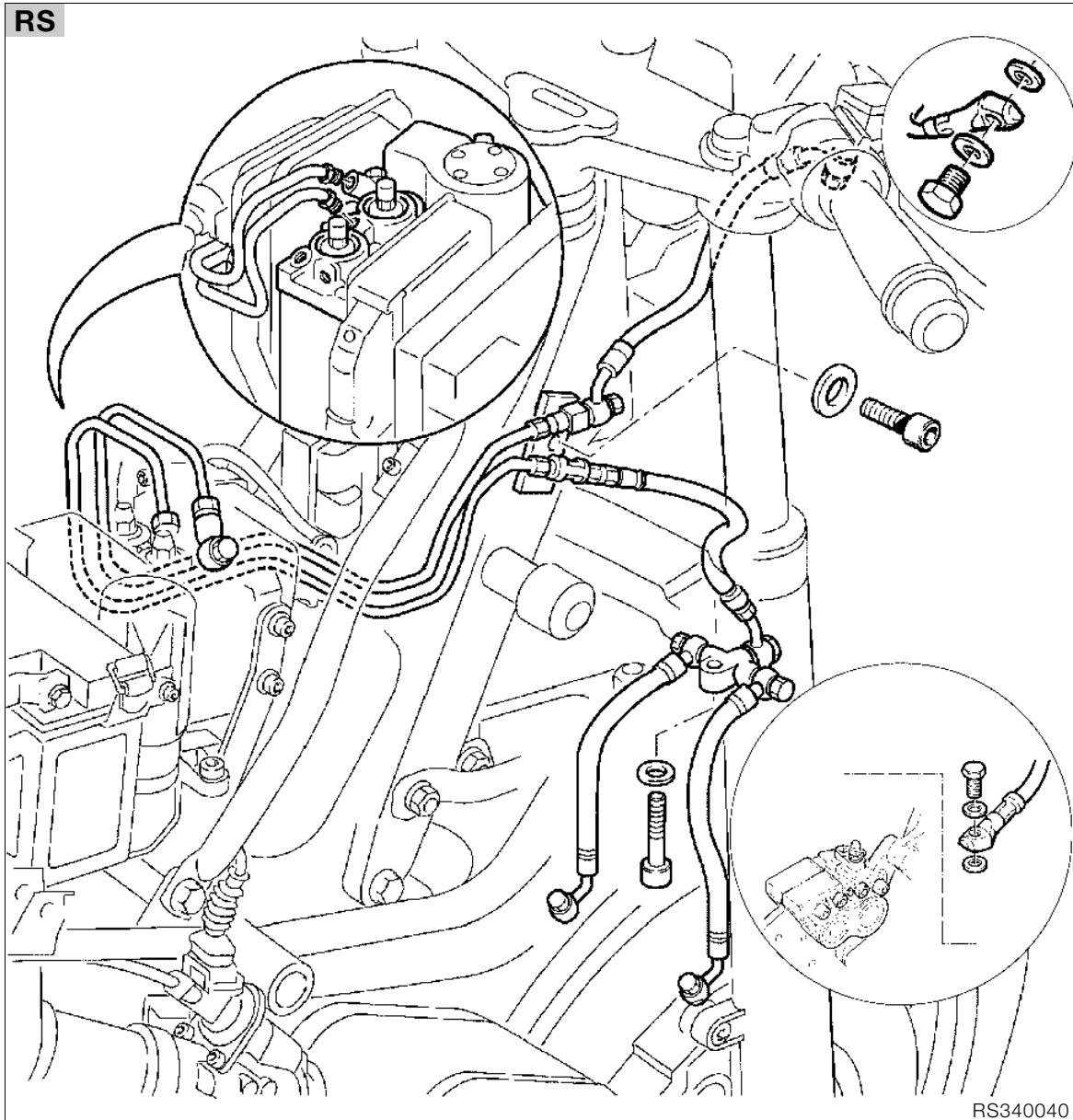
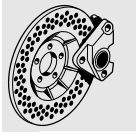

## Removing and installing front ABS brake line

RS

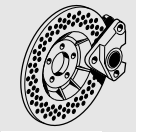
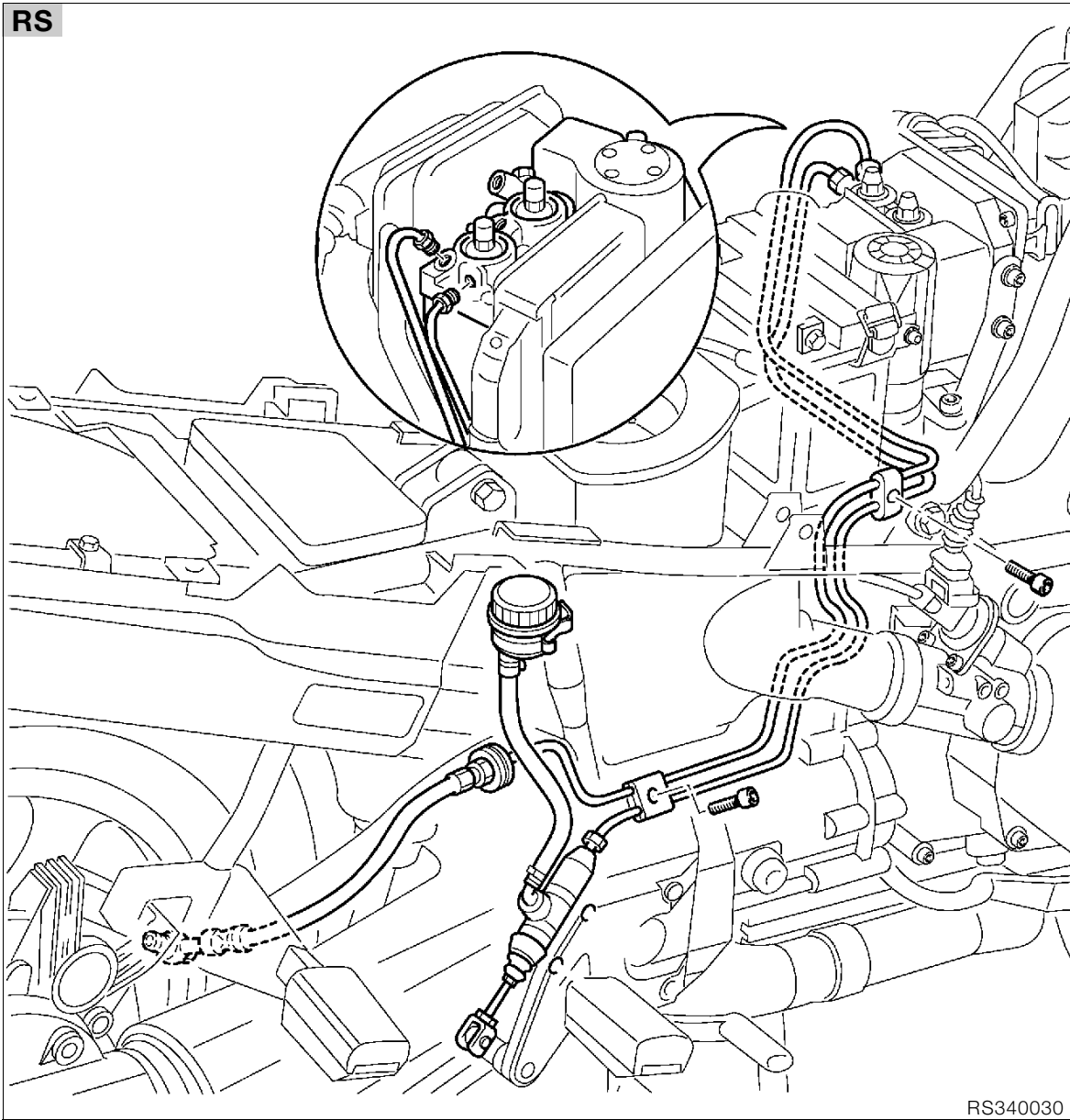

RS340030

### Removing and installing rear ABS brake line



- Drain fluid from brake system.



**Caution:**

Do not allow brake fluid to come into contact with painted parts of the motorcycle, because brake fluid destroys paint.

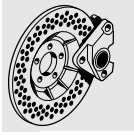

- **[ABS]** Removing fuel tank.
- **[RS]** Removing front section of front mudguard.
- **[GS]** Removing front mudguard.
- Remove brake lines.
- Install in the reverse order of work.



**Caution:**

Renew sealing rings for brake line.

Attach brake line to master cylinder so that it cannot become kinked or abraded when the handlebar is turned.

**[RS/adjustable handlebar]** In its center position, the brake hose fitting must have adequate clearance at the center section of the handlebar (app. 5...10 mm (0.11969...0.3937in)). If necessary, unfasten the wiring harness.

- Fill/bleed the brake system.



**Tightening torque:**

Brake line to fitting .....	15 Nm
Brake line to front/rear brake caliper .....	15 Nm
Brake line at fluid distributor .....	15 Nm
Flow distributor to slider tube bridge	
<b>[RS/GS]</b> .....	9 Nm
Flow distributor to holder/slider tube	
<b>[R/RT]</b> .....	9 Nm
Bleed screws .....	7 Nm
Bleed screw on rear brake caliper	
<b>[GS/R/RT]</b> .....	4 Nm
<b>[ABS]</b> Bleed screw at ABS unit .....	9 Nm
<b>[ABS]</b> Distributor block to frame .....	9 Nm
<b>[ABS]</b> Brake line at ABS unit .....	15 Nm

# 36 Wheels and tyres

Contents	Page
<b>Technical Data</b> .....	3
<b>Removing and installing front wheel</b> .....	7
Removing front wheel .....	7
Installing front wheel .....	7
Removing and installing wheel bearings .....	8
<b>[RS/R/RT] Removing and installing rear wheel (cast alloy)</b> .....	10
Removing rear wheel .....	10
Installing rear wheel .....	10
<b>[GS/R] Removing and installing rear wheel (spoked)</b> .....	11
Removing rear wheel .....	11
Installing rear wheel .....	11
<b>Static balancing of front wheel/rear wheel</b> .....	12
<b>Checking front/rear wheel rim for runout</b> .....	13
<b>[GS/R (spoked wheel)] Removing and installing spokes</b> .....	14
<b>[GS/R (spoked wheel)] Centering wheel rim</b> .....	14
Centering horizontal runout .....	14

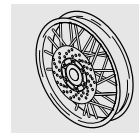

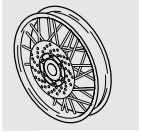

Technical Data			R 1100 RS	
Rim size	front		3.50 x 17 MT H 2	
	rear		4.50 x 18 MT H 2	
Max. vertical/lateral runout	front	mm (in)	Cast wheel 0.5 (0.0197)	
	rear	mm (in)	0.3 (0.0118)	
Tyre size	front		Cast wheel 120/70 ZR 17 Tubeless	
	rear		160/60 ZR 18 Tubeless	
Tyre pressure (cold)	Solo	front	bar (psi)	2.2 (31.91)
		rear	bar (psi)	2.5 (36.26)
	With pillion passenger	front	bar (psi)	2.5 (36.26)
		rear	bar (psi)	2.7 (39.16)
	With pillion passenger and luggage	front	bar (psi)	2.5 (36.25)
		rear	bar (psi)	2.9 (42.06)

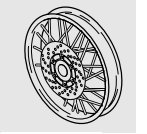

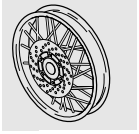

Technical Data			R 1100 RT
Rim size	front		3,50 x 17 MT H 2
	rear		4,50 x 18 MT H 2
Max. vertical/lateral runout	front	mm (in)	Cast wheel 0.5 (0.0197)
	rear	mm (in)	0.3 (0.0118)
Tyre size	front		Cast wheel 120/70 ZR 17 Tubeless
	rear		160/60 ZR 18 Tubeless
Tyre pressure (cold)	Solo		
	front	bar (psi)	2.2 (31.91)
	rear	bar (psi)	2.5 (36.26)
With pillion passenger	front	bar (psi)	2.5 (36.26)
	rear	bar (psi)	2.7 (39.16)
With pillion passenger and luggage	front	bar (psi)	2.5 (36.25)
	rear	bar (psi)	2.9 (42.06)

Technical Data				R 850 GS	R 1100 GS
Rim size		front		2,50 x 19 MT H 2	2,50 x 19 MT H 2
		rear		4,00 x 17 MT H 2	4,00 x 17 MT H 2
Max. vertical/lateral runout		front	mm (in)	Spoked wheel 1.3 (0.0512)	Spoked wheel 1.3 (0.0512)
		rear	mm (in)	1.3 (0.0512)	1.3 (0.0512)
Tyre size		front		Spoked wheel 110/80 R 19 59 H Tubeless	Spoked wheel 110/80 R 19 59 H Tubeless
		rear		150/70 R 17 69 H Tubeless	150/70 R 17 69 H Tubeless
Tyre pressure (cold)					
Solo		front	bar (psi)	2.2 (31.91)	2.2 (31.91)
		rear	bar (psi)	2.5 (36.26)	2.5 (36.26)
With pillion passenger		front	bar (psi)	2.5 (36.26)	2.5 (36.26)
		rear	bar (psi)	2.7 (39.16)	2.7 (39.16)
With pillion passenger and luggage		front	bar (psi)	2.5 (36.25)	2.5 (36.25)
		rear	bar (psi)	2.9 (42.06)	2.9 (42.06)

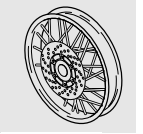

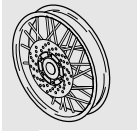

Technical Data				R 850 R	R 1100 R
Rim size	front			Cast wheel	Cast wheel
				3,50 x 17 MT H 2	3,50 x 17 MT H 2
	rear			4,50 x 18 MT H 2	4,50 x 18 MT H 2
				Spoked wheel	Spoked wheel
front			2,50 x 18 MT H 2	2,50 x 18 MT H 2	
			rear		
Max. vertical/lateral runout	front	mm (in)		Cast wheel	Cast wheel
				0.5 (0.0197)	0.5 (0.0197)
	rear	mm (in)		0.3 (0.0118)	0.3 (0.0118)
				Spoked wheel	Spoked wheel
front	mm (in)		1.3 (0.0512)	1.3 (0.0512)	
			rear	mm (in)	
Tyre size	front			Cast wheel	Cast wheel
				120/70 ZR 17 Tubeless	120/70 ZR 17 Tubeless
	rear			160/60 ZR 18 Tubeless	160/60 ZR 18 Tubeless
				Spoked wheel	Spoked wheel
front			110/80 ZR 18 Tubeless	110/80 ZR 18 Tubeless	
			rear		
Tyre pressure (cold)	Solo	front	bar (psi)	2.2 (31.91)	2.2 (31.91)
				rear	bar (psi)
	With pillion passenger	front	bar (psi)	2.5 (36.26)	2.5 (36.26)
				rear	bar (psi)
	With pillion passenger and luggage	front	bar (psi)	2.5 (36.25)	2.5 (36.25)
				rear	bar (psi)

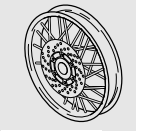
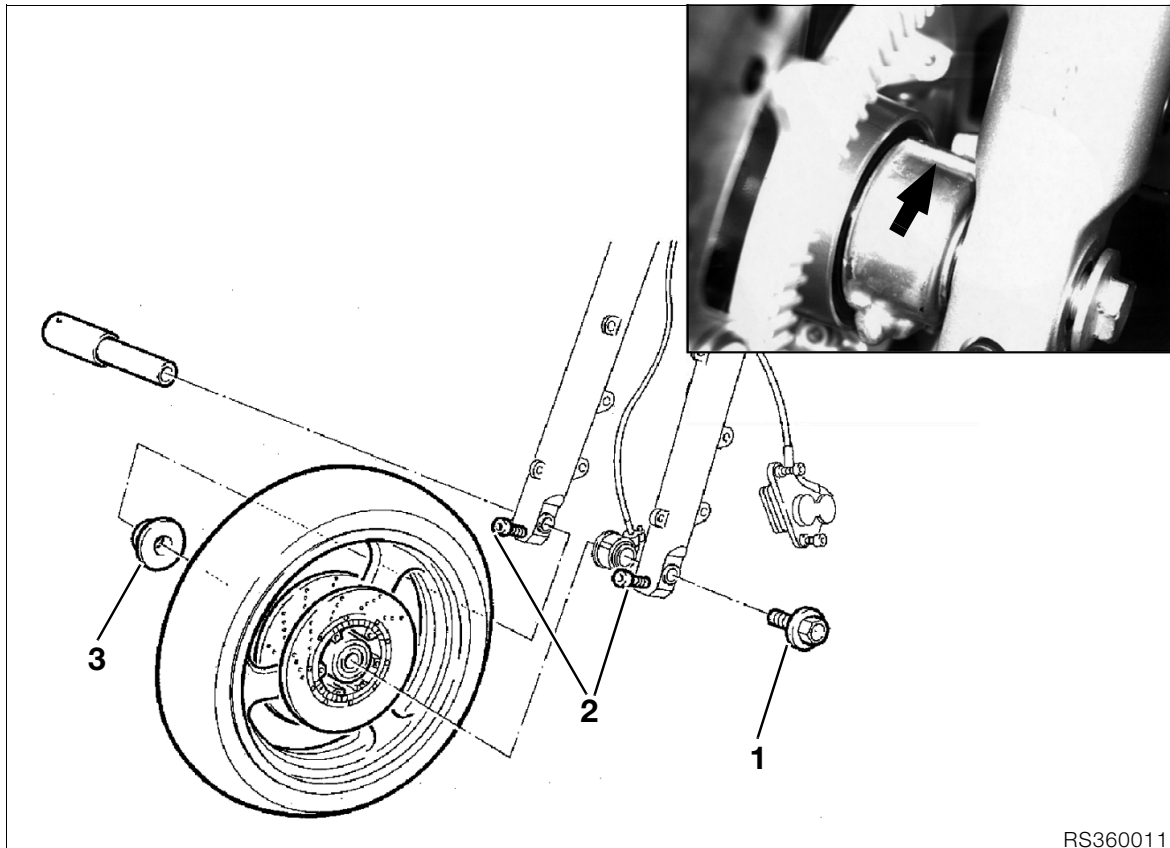

RS360011

## Removing and installing front wheel

### Removing front wheel

- **[RS/RT]** Remove front mudguard.
- Remove brake calipers.



#### Caution:

**[RS/R/RT]** Do not scratch rim; mask off with tape if necessary. Do not tilt the brake caliper: risk of damage to brake pads.



#### Note:

Do not apply handbrake lever with brake calipers removed/front wheel removed.

- Remove retaining screw (1).
- Loosen clamping screws (2).
- Remove quick-release axle.
- Remove spacer bushing (3) and speedometer drive.
- Remove front wheel.

### Installing front wheel

- Install front wheel.
- Install spacer bushing and speedometer drive.



#### Caution:

Anti-twist device (arrow) on speedometer drive is located in front of stop on slider tube.

- Apply a light coating of **Molykote paste** to the quick-release axle/install it.
- Tighten retaining screw (1).
- Press forks down firmly several times.
- Tighten clamping screws (2).
- Install brake calipers.
- **[RS/RT]** Install front mudguard.
- **[ABS]** Check sensor gap and adjust if necessary.

**ABS sensor gap** ..... 0.45...0.55 mm  
 ..... (0.0177...0.02165 in)



#### Tightening torque:

Screw connection, quick-release axle ..... 30 Nm  
 Clamping screws, quick-release axle ..... 22 Nm  
 Brake caliper to slider tube ..... 40 Nm



## Removing and installing wheel bearings

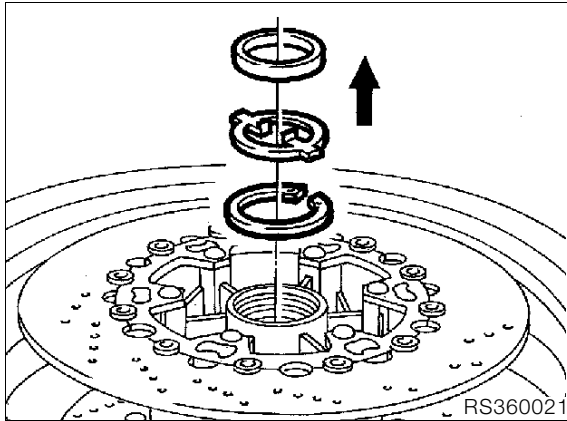
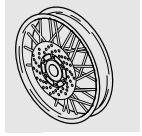

- Remove shaft seal, driver and retaining ring.

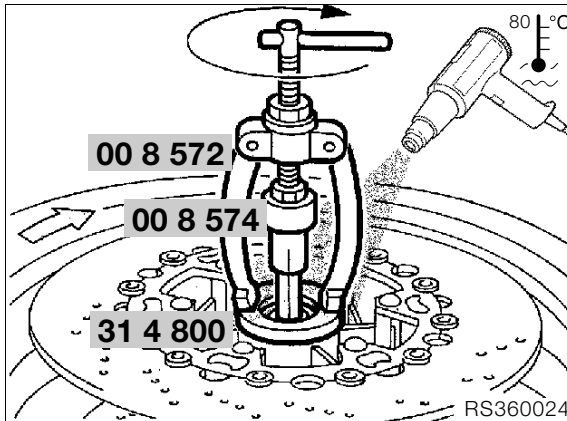

- Clamp arbor, **BMW No. 36 5 511**, in vise and place wheel on it with the broad bearing in contact with the arbor.
- Place spacing ring, **BMW No. 31 4 800**, between wheel hub/right side of wheel and claws of internal puller.
- Heat bearing seat to 80 °C.
- Pull out wheel bearing with counter-support 22/1, **BMW No. 00 8 572**, and internal puller 21/3, **BMW No. 00 8 574**.

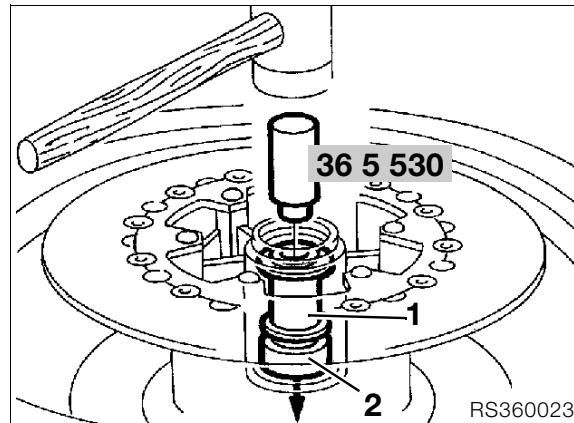

- Press out spacing bushing (1) and wheel bearing (2) with drift, **BMW No. 36 5 530**.
- Press reducing bushing out of bearing with drift, **BMW No. 36 5 530/** into new bearing.
- Degrease bearing seats.

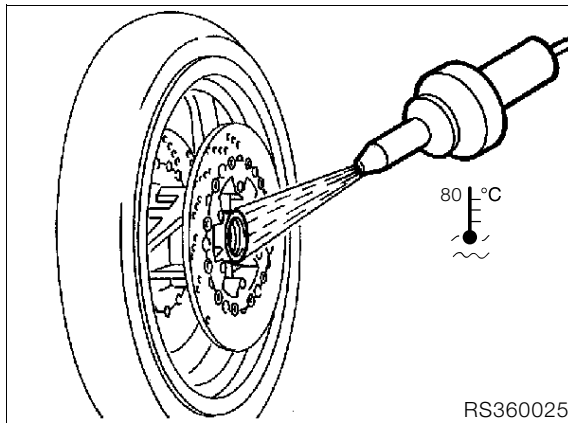

- Heat bearing seat.

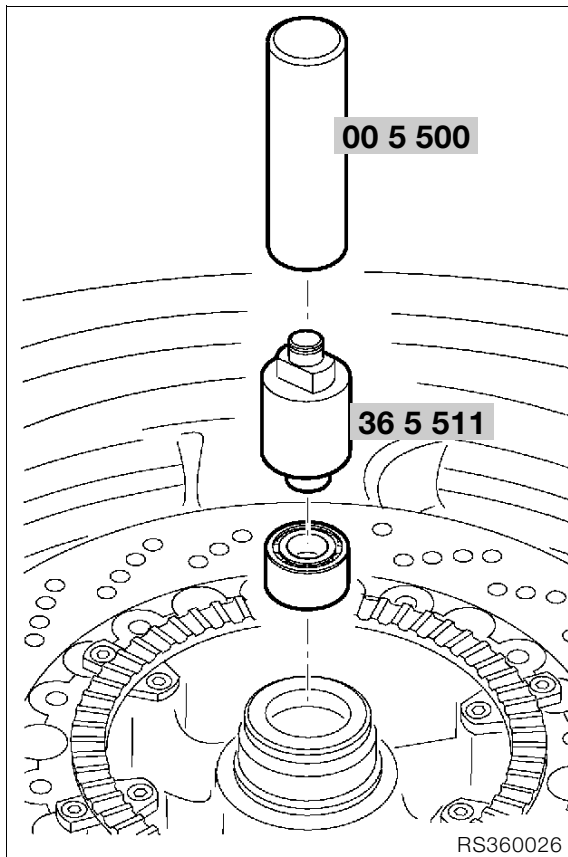

- **First** insert wide bearing using drift, **BMW No. 36 5 511**, and handle, **BMW No. 00 5 500**.

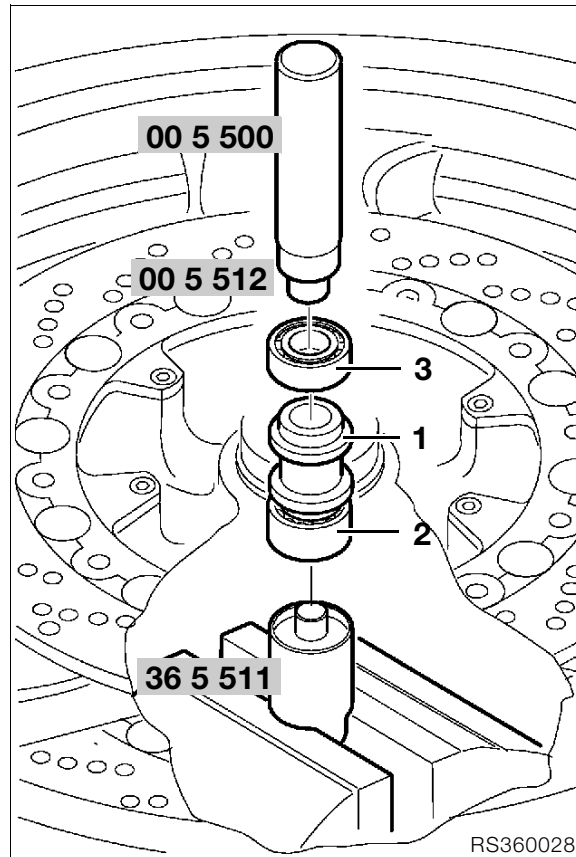

- Clamp arbor, **BMW No. 36 5 511**, in vise and place wheel on it with wide bearing (2) in contact with arbor.
- Install spacer tube (1).
- Bearing seat temperature 80 °C.
- Insert narrow bearing (3) with drift, **BMW No. 36 5 512**, and handle, **BMW No. 00 5 500**.

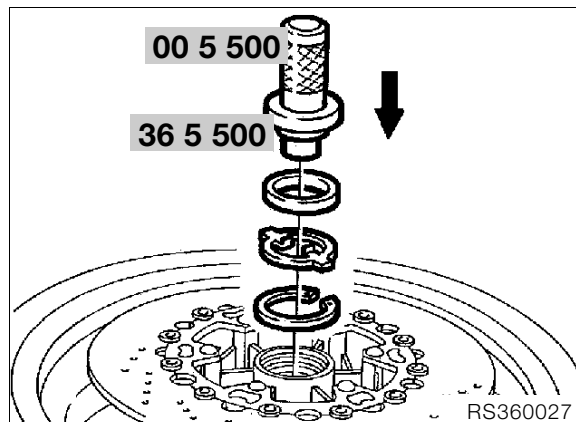

- Install retaining ring and driver.
- Drive in shaft sealing ring with drift, **BMW No. 36 5 500**, and handle, **BMW No. 00 5 500**.

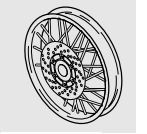

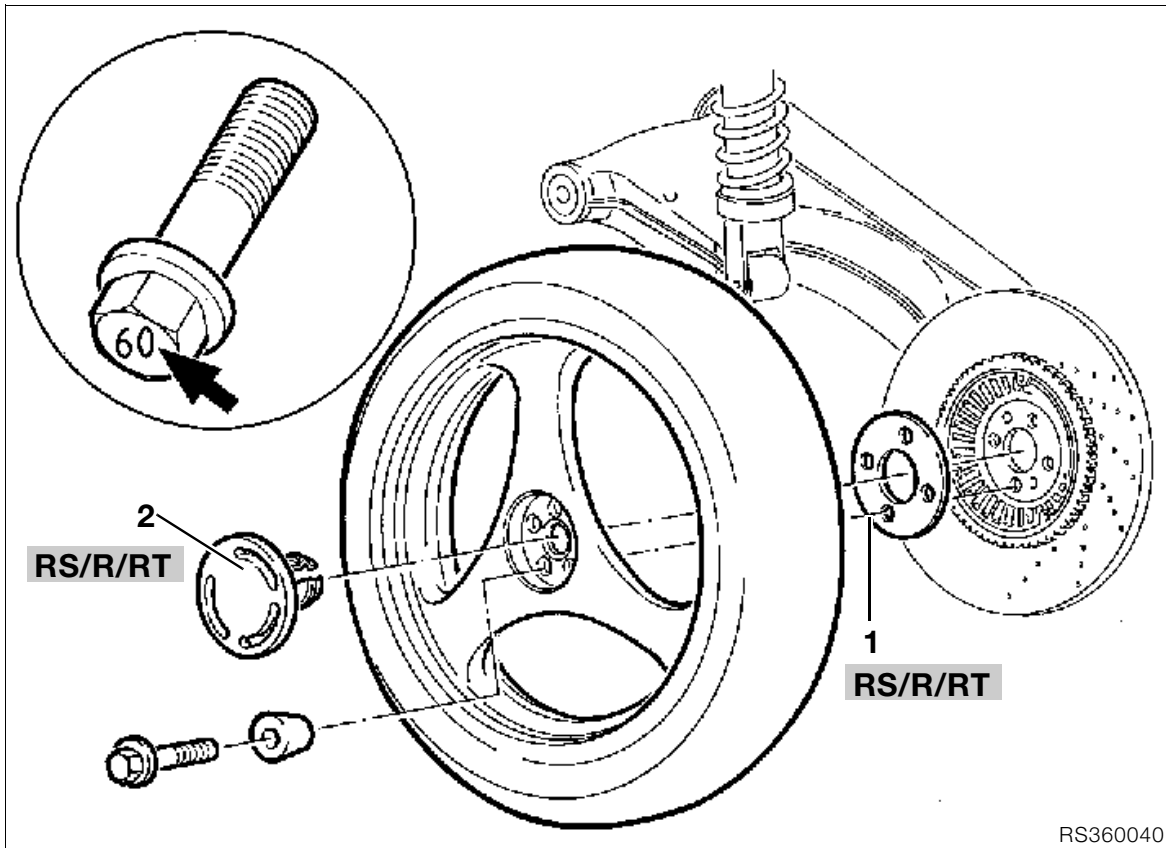
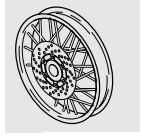

RS360040

### [RS/R/RT] Removing and installing rear wheel (cast alloy)

#### Removing rear wheel

- [RS] Remove number plate carrier.
- [RS/ABS] Detach muffler (silencer) mount/press muffler outwards/carefully remove the rear wheel.

#### Installing rear wheel

##### **Caution:**

The spacing washer (1) and the contact faces on the rear wheel drive and the hub must be clean and free from grease.

- [RS/ABS] Press the muffler outwards.
- Fit rear wheel to rear wheel drive with spacer disc (1) and insert wheel studs hand-tight.

##### **Caution:**

Only use wheel studs with length code 60. Do not oil or grease wheel studs!

- Tighten wheel studs.
- Install hub cap (2).



##### **Note:**

Insert lug on cover in recess in wheel.

- Install number plate holder.
- [RS/ABS] Bolt on the muffler mount.



##### **Tightening torque:**

Screw in wheel studs handtight, then tighten them in a crosswise pattern

Initial tightening .....	50 Nm
Final tightening .....	105 Nm

## [GS/R] Removing and installing rear wheel (spoked)

### Removing rear wheel

- Unfasten/remove brake caliper.
- Remove rear wheel.



---

**Note:**

**[GS]** To remove the wheel, carefully bend the rear wheel cover to the right/do not remove it.

---

### Installing rear wheel

**Caution:**

Contact faces on rear wheel drive and hub must be clean and free of grease.

---

- Fit rear wheel to rear wheel drive and screw in wheel studs hand-tight.

**Caution:**

Only use wheel studs with length code 60.  
Do not oil or grease wheel studs!

---

- Tighten wheel studs.

**Tightening torque:**

Screw in the wheel studs handtight and tighten them in a crosswise pattern

Initial tightening ..... 50 Nm

Final tightening ..... 105 Nm

- Install brake caliper.
- **[ABS]** Check sensor gap.

**[ABS] Sensor gap** ..... 0.45...0.55 mm  
..... (0.0177...0.02165 in)

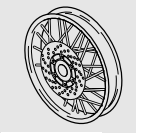

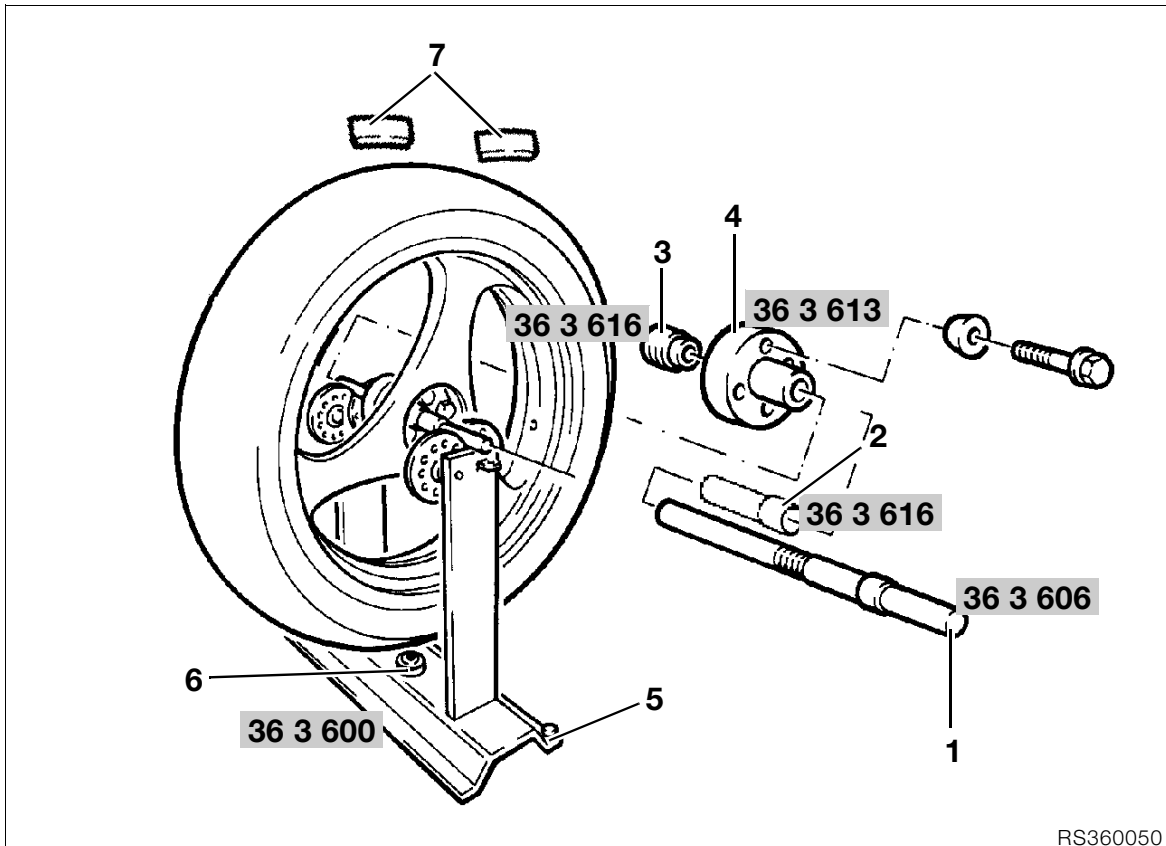
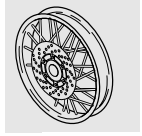

## Static balancing of front wheel/rear wheel

- Install balancing shaft (1), **BMW No. 36 3 606**, with measuring bushing (2) and nut (3), **BMW No. 36 3 616**, in the front wheel bearings.
- Lightly preload bearing with knurled nut (3).
- At the rear wheel, attach mounting fixture (4), **BMW No. 36 3 613**, on the centering collar side with the wheel studs and spacing washer, then install the balancing shaft.
- Align the balancing fixture, **BMW No. 36 3 600**, with knurled screws/bubble gauge (5/6).
- Allow wheel to settle.
- Clean point of adhesion.
- Attach adhesive weights (7) opposite heaviest point of wheel (arrow), evenly distributed on both sides (left/right) of rim.



### Caution:

Maximum balancing weight 60 g (2.1 oz.).

- Repeat balancing procedure as a check.

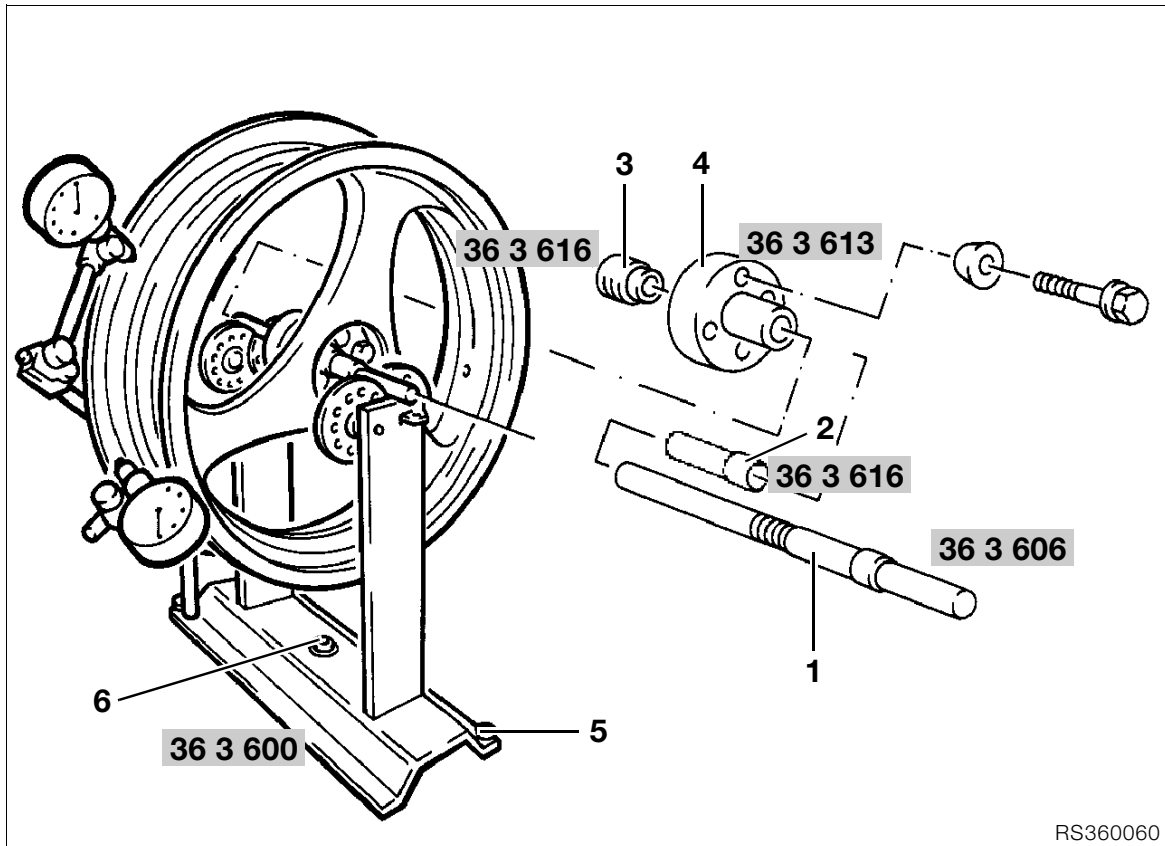

RS360060

## Checking front/rear wheel rim for runout

- Remove tyre.
- Install balancing shaft (1), **BMW No. 36 3 606**, together with measuring bushing (2) and nut (3), **BMW No. 36 3 616**, in the front wheel bearings.
- Lightly preload bearing with knurled nut (3).
- Prevent balancing shaft from turning by inserting pin at balancing frame.
- At the rear wheel, attach the mounting fixture (4), **BMW No. 36 3 613**, on the centering collar side with the wheel studs and a spacing washer, then install the balancing shaft.
- Clamp locating discs, **BMW No. 36 3 615**, on the balancing shaft at left and right so that the shaft cannot wander.
- Align the balancing fixture, **BMW No. 36 3 600**, with knurled screws/bubble gauge (5/6).
- Check radial/axial runout.



### Caution:

Only apply dial gauge to machined inner face of wheel rim.

### Max. vertical runout/lateral runo

#### Cast alloy wheel

front ..... 0.5 mm (0.0197 in)  
 rear ..... 0.3 mm (0.0118 in)

#### Spoked wheel

front/back..... 1.3 mm (0.0512 in)

## [GS/R (spoked wheel)] Removing and installing spokes

## Centering horizontal runout

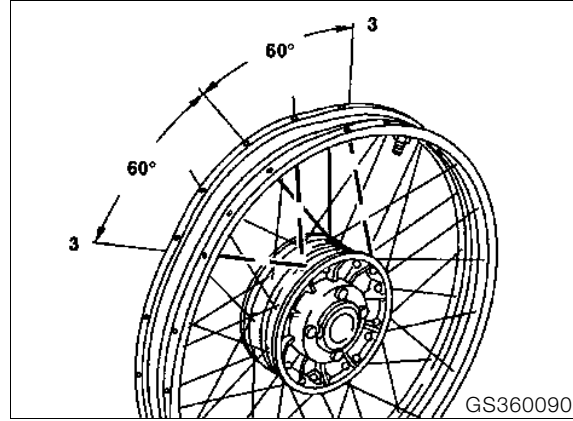
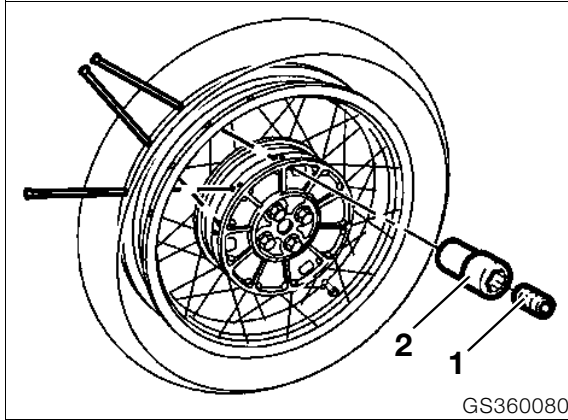
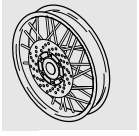

### Caution:

It is not permitted to replace more than one spoke.

- Unfasten grub screw (1).
- Unfasten spoke nipple (2)/remove spoke.
- Install new spoke.
- Center the wheel rim.

- Determine maximum deviation (plus (+) and minus (-)).
- To center the wheel, the spoke nipples must be tightened on the side directly opposite the largest deviation.
- Remove grub screw from relevant spoke nipple before tightening.
- Working forwards and backwards from the maximum and minimum value points, take up slack at every 3rd spoke nipple.



### Tightening torque:

Spoke nipple ..... 5 Nm



### Caution:

Never attempt to compensate for the entire horizontal runout at only one or two spokes.

## [GS/R (spoked wheel)] Centering wheel rim

**Max. permissible lateral/vertical runout**... 1.3 mm  
..... (0.0512 in)

**Max. horizontal runout which can be eliminated by centering**..... 2.0 mm  
..... (0.0787 in)



### Note:

Vertical runout cannot be compensated for by centering the rim.

- At the point where the maximum plus and minus values occur, take up slack at 2 spokes.
- Four spokes are therefore tightened during each centering operation.
- Check horizontal runout with a dial gauge.
- After every correction of horizontal runout, check vertical runout again.
- If necessary, repeat the centering operation.
- Lock tightened spokes into place with grub screws.



### Tightening torque:

Spoke nipple ..... 5 Nm  
Grub screw ..... 1 Nm

# 46 Frame

<b>Contents</b>	<b>Page</b>
<b>Technical Data</b> .....	3
<b>General view, frame</b> .....	7
<b>[RT] General view of fairing sections</b> .....	8
<b>[RT] Removing and installing front mudguard</b> .....	9
<b>[RT] Removing and installing fairing sections</b> .....	10
<b>[RT] Removing and installing wind-shield</b> .....	11
<b>[RT] Removing and installing inner fairing panel</b> .....	12
<b>[RT] Removing and installing upper section of fairing</b> .....	13
<b>[RT] Removing and installing fairing holder</b> .....	14
<b>[RT] Removing and installing luggage rack/case holder</b> .....	15
<b>[RT] Removing and installing rear fairing</b> .....	16
<b>[RT] Removing and installing number plate mount</b> .....	17
<b>[RT] Removing and installing lower rear section</b> .....	18
<b>[RT/GS/R] Removing and installing center stand</b> .....	19
<b>Removing and installing side stand</b> .....	20
<b>[RT] Removing and installing left footrest plate</b> .....	21
<b>[RT] Removing and installing right footrest plate</b> .....	22
<b>[RT] Removing and installing frame</b> .....	23
<b>[RS] Removing and installing front mudguard</b> .....	24
<b>[RS] Removing and installing side sections of fairing</b> .....	25
<b>[RS] Removing and installing side sections of full fairing</b> .....	26
<b>[RS] Removing and installing wind-shield</b> .....	27
<b>[RS] Removing and installing adjustable windshield</b> .....	28
<b>[RS] Removing and installing inner fairing panel</b> .....	29
<b>[RS] Removing and installing top section of fairing</b> .....	30
<b>[RS] Removing and installing fairing holder</b> .....	31





# Contents

Page

<b>Removing and installing frame</b> .....	32
<b>[RS] Removing and installing grab handle/case holder</b> .....	33
<b>[RS] Removing and installing rear fairing</b> .....	34
<b>[RS] Removing and installing number plate bracket</b> .....	35
<b>[RS] Removing and installing lower rear section</b> .....	36
<b>Removing and installing rear section of frame</b> .....	37
<b>[RS] Removing and installing center stand</b> .....	38
<b>[RS] Removing and installing rear footrest plate</b> .....	40
<b>[RS/R] Removing and installing front footrest plate</b> .....	41
<b>[GS/R] Removing and installing front mudguard</b> .....	42
<b>[GS] Removing and installing windshield</b> .....	43
<b>[GS] Removing and installing front fairing</b> .....	44
<b>[GS] Removing and installing fairing holder</b> .....	45
<b>[GS] Removing and installing luggage rack</b> .....	46
<b>[GS/R] Removing and installing number plate bracket</b> .....	47
<b>[GS/R] Removing and installing rear mudguard</b> .....	48
<b>[GS/R] Removing and installing rear footrest plate</b> .....	49
<b>[GS] Removing and installing front footrest plate</b> .....	50
<b>[R] Removing and installing rear fairing</b> .....	51
<b>Checking running gear</b> .....	52
<b>Measuring wheel track offset</b> .....	52



Technical Data		R 1100 RS
Location of manufacturer's type plate / frame number		On frame, at right
Length, overall	mm (in)	2175 (85.63)
Max. height excl. mirrors	mm (in)	1286 (50.63)
Width over handlebar, with weights	mm (in)	735 (28.937)
Width over pillion footrests	mm (in)	667 (26.26)
Height of seat at unladen weight	mm (in)	800 (31.496)
- with adjustable seat	mm (in)	780/800/820 (30.71/31.496/32.28)
Wheelbase in normal-load position	mm (in)	1473 (57.99)
Ground clearance in normal-load position	mm (in)	153 (6.024)
Caster angle in normal-load position	mm (in)	111 (4.37)
Steering head angle in normal-load position	°	64.5
Max. heel angle with 85 kg (187.425 lb) rider	°	49
Max.wheel track offset	mm (in)	9 (0.354)
Unladen weight, ready for road, full tank	kg (lb)	239 (526.995)
Axle load distribution (without rider), front/rear	%	52.7/47.3
Permitted total weight	kg (lb)	450 (992.25)





Technical Data		R 1100 RT
Location of manufacturer's type plate / frame number		On frame, at right
Length, overall	mm (in)	2230 (87.795)
Max. height excl. mirrors	mm (in)	1380 (54.33)
Width over handlebar, with weights	mm (in)	775 (30.512)
Width over pillion footrests	mm (in)	677 (26.65)
Height of seat at unladen weight	mm (in)	800 (31.496)
- with adjustable seat	mm (in)	780/800/820 (30.71/31.496/32.28)
Wheelbase in normal-load position	mm (in)	1485 (58.4645)
Ground clearance in normal-load position	mm (in)	153 (6.024)
Caster angle in normal-load position	mm (in)	122 (4.803)
Steering head angle in normal-load position	°	62.9
Max. heel angle with 85 kg rider	°	46
Max.wheel track offset	mm (in)	9 (0.354)
Unladen weight, ready for road, full tank	kg (lb)	275 (606.375)
Axle load distribution (without rider), front/rear	%	51/49
Permitted total weight	kg (lb)	490 (1080.45)

<b>Technical Data</b>		<b>R 850 GS</b>	<b>R 1100 GS</b>
Location of manufacturer's type plate / frame number		On frame, at right	On frame, at right
Length, overall	mm (in)	2189 (86.18)	2189 (86.18)
Max. height excl. mirrors	mm (in)	1366 (53.7796)	1366 (53.7796)
Width over handlebar, with weights	mm (in)	890 (35.039)	890 (35.039)
Width over pillion footrests	mm (in)	734 (28.897)	734 (28.897)
Height of seat at unladen weight	mm (in)	840/860 (33.07/33.858)	840/860 (33.07/33.858)
Wheelbase in normal-load position	mm (in)	1509 (59.409)	1509 (59.409)
Ground clearance in normal-load position	mm (in)	200 (7.874)	200 (7.874)
Caster angle in normal-load position	mm (in)	115 (4.5275)	115 (4.5275)
Steering head angle in normal-load position	°	62.9	62.9
Max. heel angle with 85 kg rider	°	47	47
Max.wheel track offset	mm (in)	9 (0.354)	9 (0.354)
Unladen weight, ready for road, full tank	kg (lb)	243 (535.815)	243 (535.815)
Axle load distribution (without rider), front/rear	%	50.6/49.4	50.6/49.4
Permitted total weight	kg (lb)	450 (992.25)	450 (992.25)





<b>Technical Data</b>		<b>R 850 R</b>	<b>R 1100 R</b>
Location of manufacturer's type plate / frame number		On frame, at right	On frame, at right
Length, overall	mm (in)	2197 (86.496)	2197 (86.496)
Max. height excl. mirrors	mm (in)	1170 (46.062)	1170 (46.062)
Width over handlebar, with weights	mm (in)	761 (29.96)	761 (29.96)
Width over pillion footrests	mm (in)	734 (28.897)	734 (28.897)
Height of seat at unladen weight	mm (in)	760/780/800	760/780/800
Wheelbase in normal-load position	mm (in)	1487 (58.543)	1487 (58.543)
Ground clearance in normal-load position	mm (in)	138 (5.433)	138 (5.433)
Caster angle in normal-load position	mm (in)	127 (5)	127 (5)
Steering head angle in normal-load position	°	61.9	61.9
Max. heel angle with 85 kg rider	°	45	45
Max.wheel track offset	mm (in)	9 (0.354)	9 (0.354)
Unladen weight, ready for road, full tank	kg (lb)	235 (518.175)	235 (518.175)
Axle load distribution (without rider), front/rear	%	50.9/49.1	50.9/49.1
Permitted total weight	kg (lb)	450 (992.25)	450 (992.25)

# General view, frame

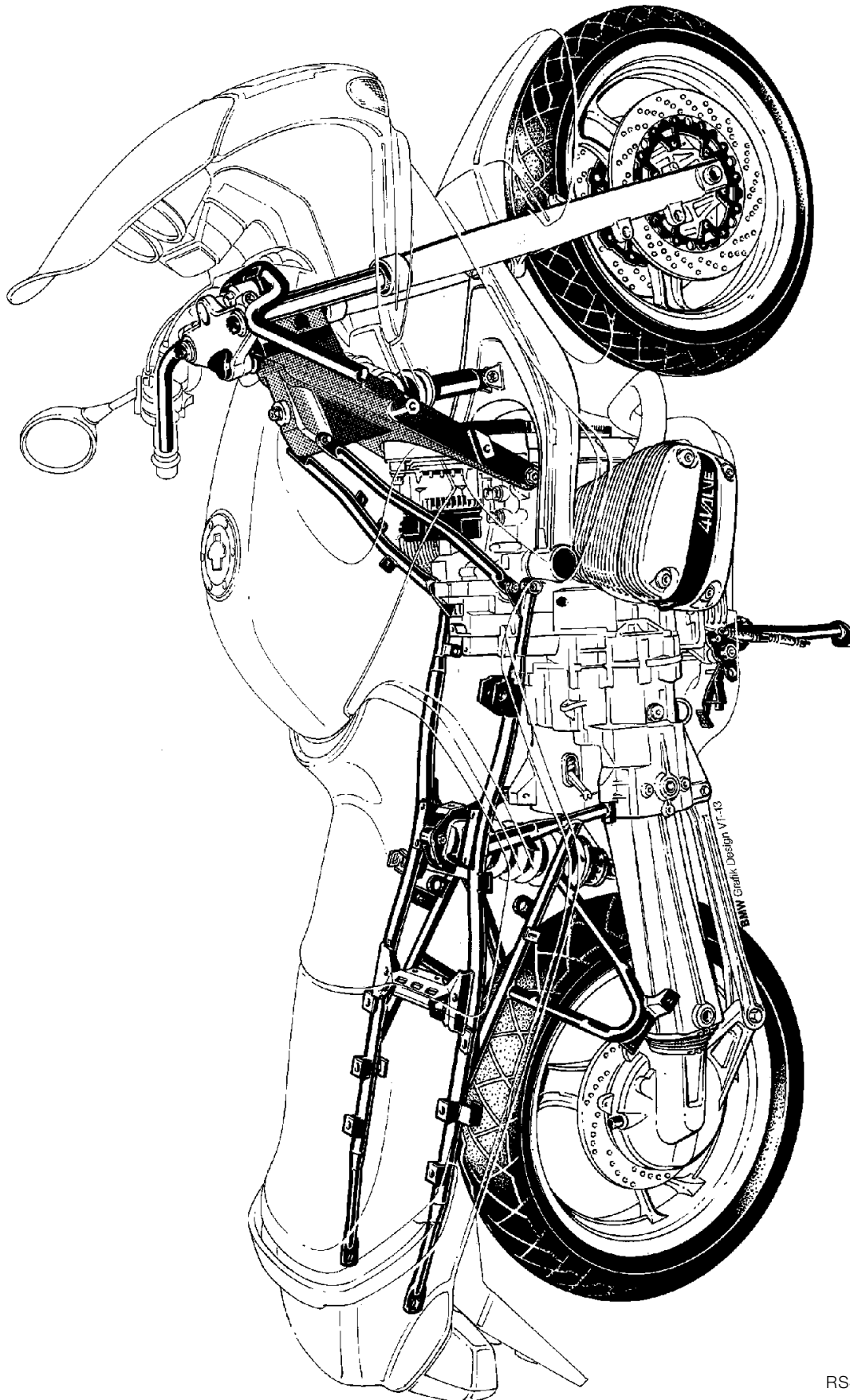

RS469010



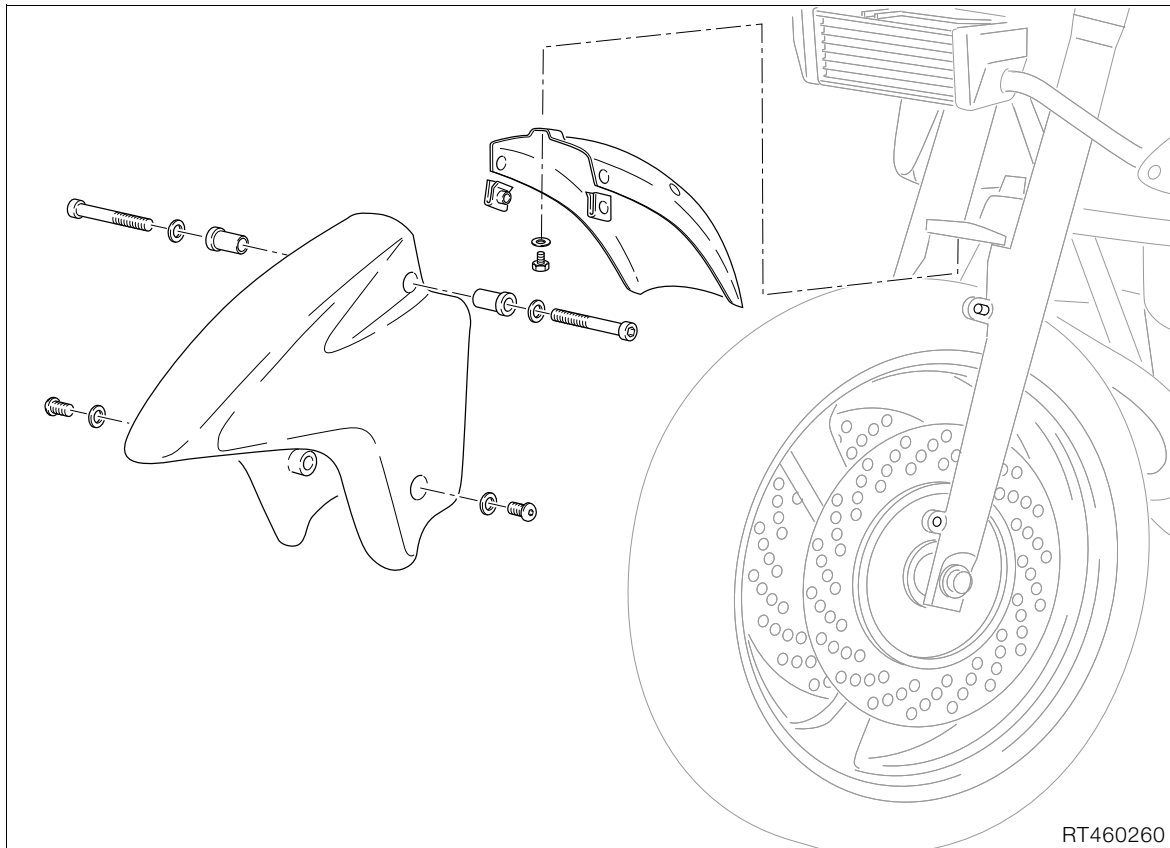

**[RT] Removing and installing front mudguard**



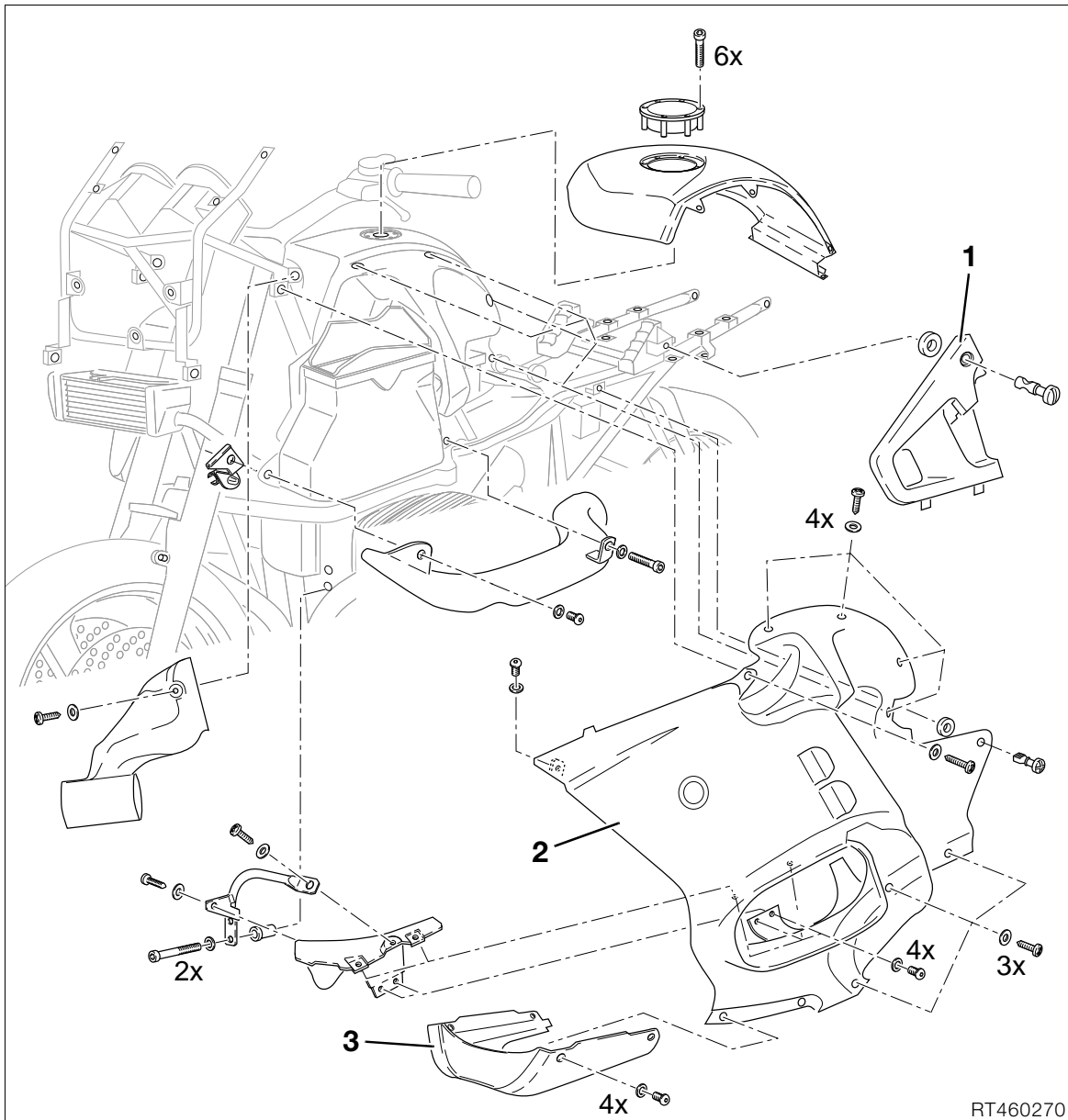

RT460270

### [RT] Removing and installing fairing sections

- Remove dualseat.
- Take off small side sections of fairing (1).
- Hold mirror with one hand. With the other hand, strike the mirror housing lightly towards the mirror surface (arrow). Take off the mirror.
- Remove side sections of fairing (2) and spoiler (3).
- Install in the reverse order of work.
- Offer the mirror at its three mounting points. Strike the mirror housing lightly, first at the front, then at the rear, to engage it

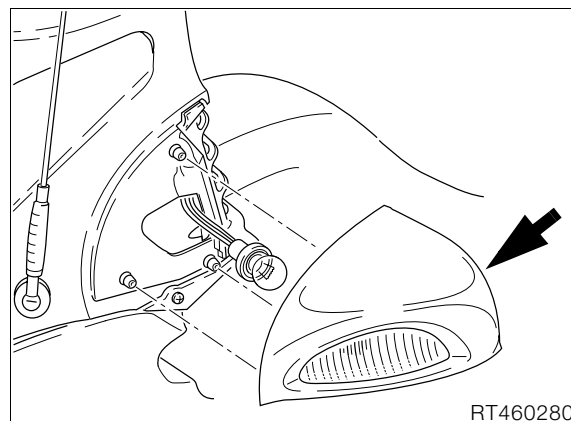

RT460280

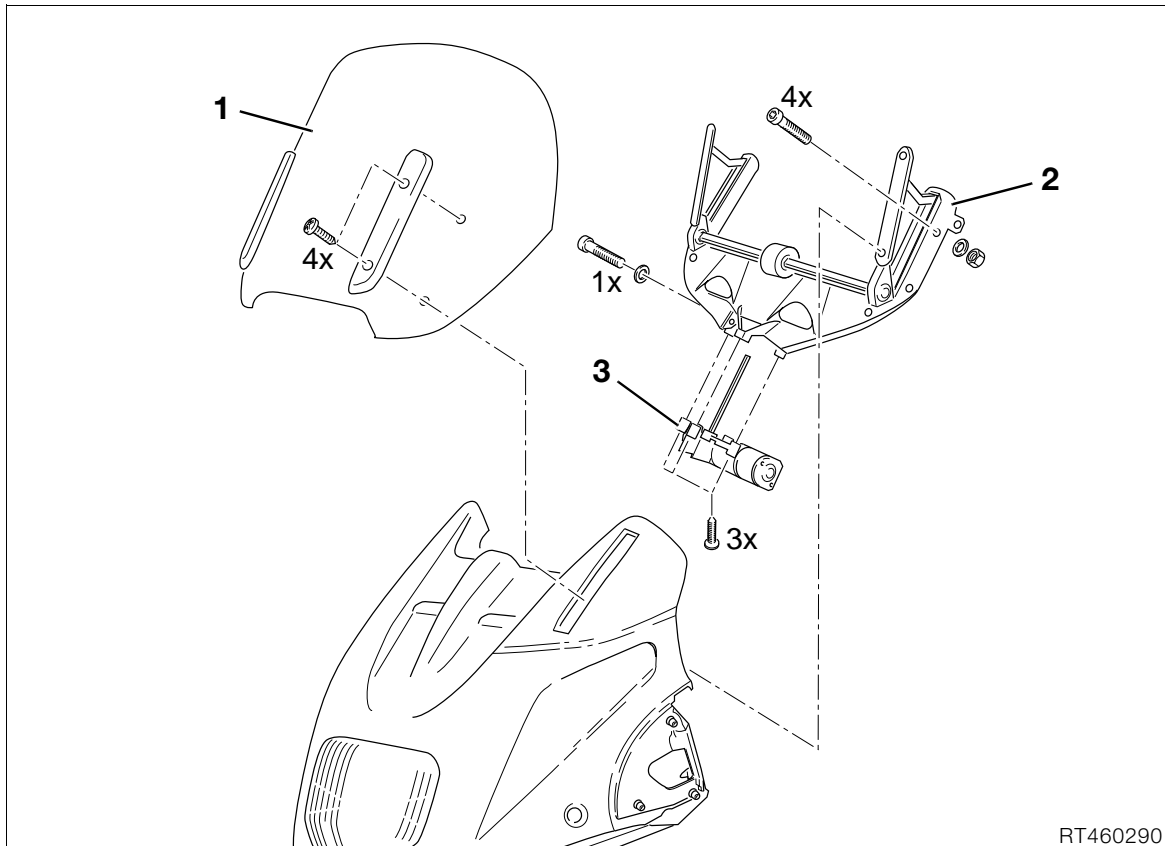

RT460290

## [RT] Removing and installing windshield

- Remove dualseat.
- Remove side mirrors.
- Remove side trim panels.
- Remove windshield (1).
- Remove inner cover for trim.
- Pull off plug at headlight.
- Detach the aerial.
- Remove upper section of fairing.
- Remove bracket (2) for windshield.
- Separate the plug connection and remove the electric drive (3).
- Install in the reverse order of work.

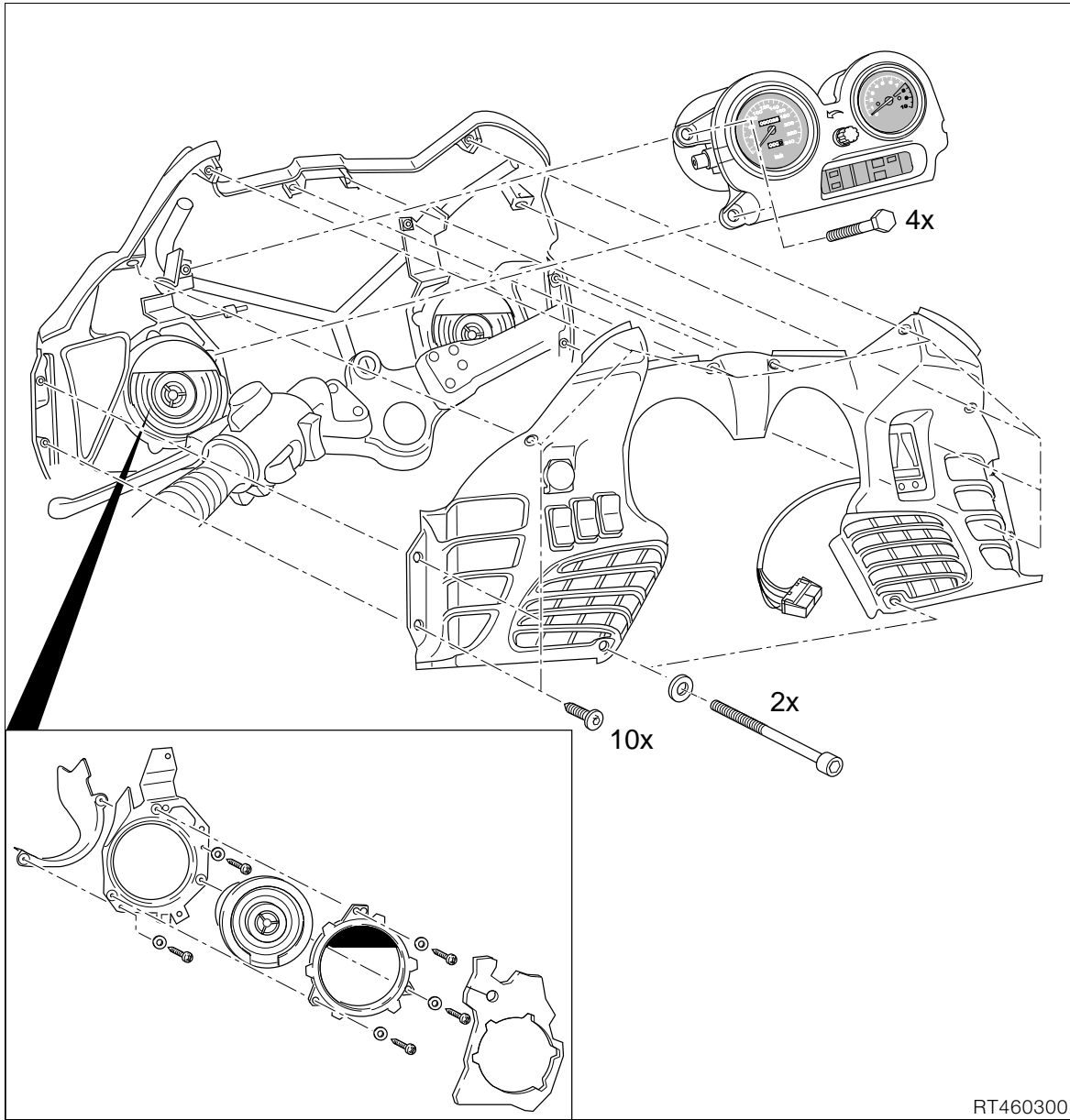

**[RT] Removing and installing inner fairing panel**

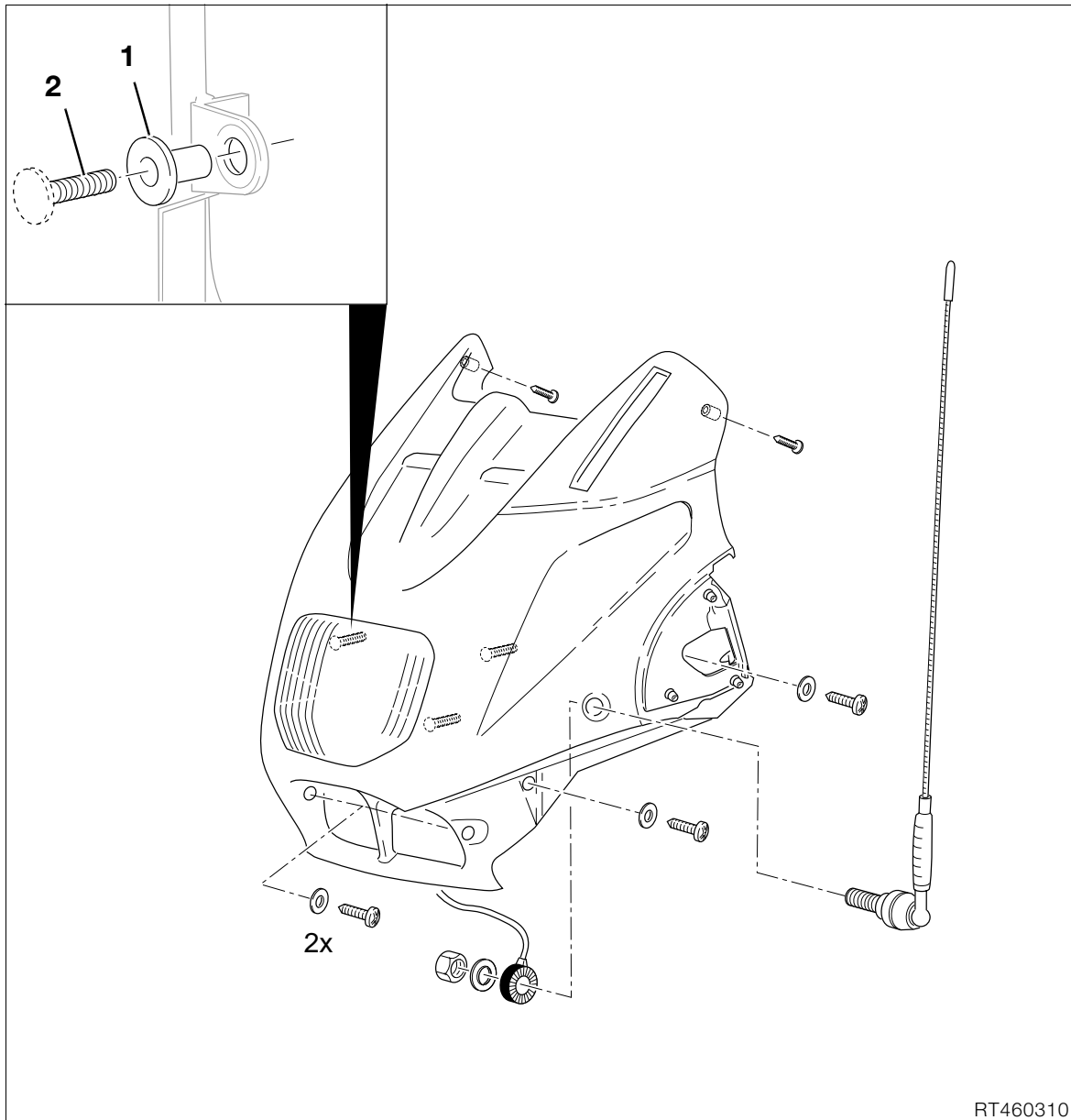

## [RT] Removing and installing upper section of fairing

- Install in the reverse order of work.



### Caution:

Switch off ignition.  
Disconnect ground (earth) lead from battery.  
Insulate ground (earth) lead.



### Note:

Before installing upper section of fairing, push metal bushings (1) on to threaded pins (2).

- Remove dualseat.
- Remove side mirrors.
- Remove side trim panels.
- Remove windshield.
- Remove inner cover for trim.
- Pull off plug for headlight.
- Detach the aerial.
- Remove upper section of fairing.

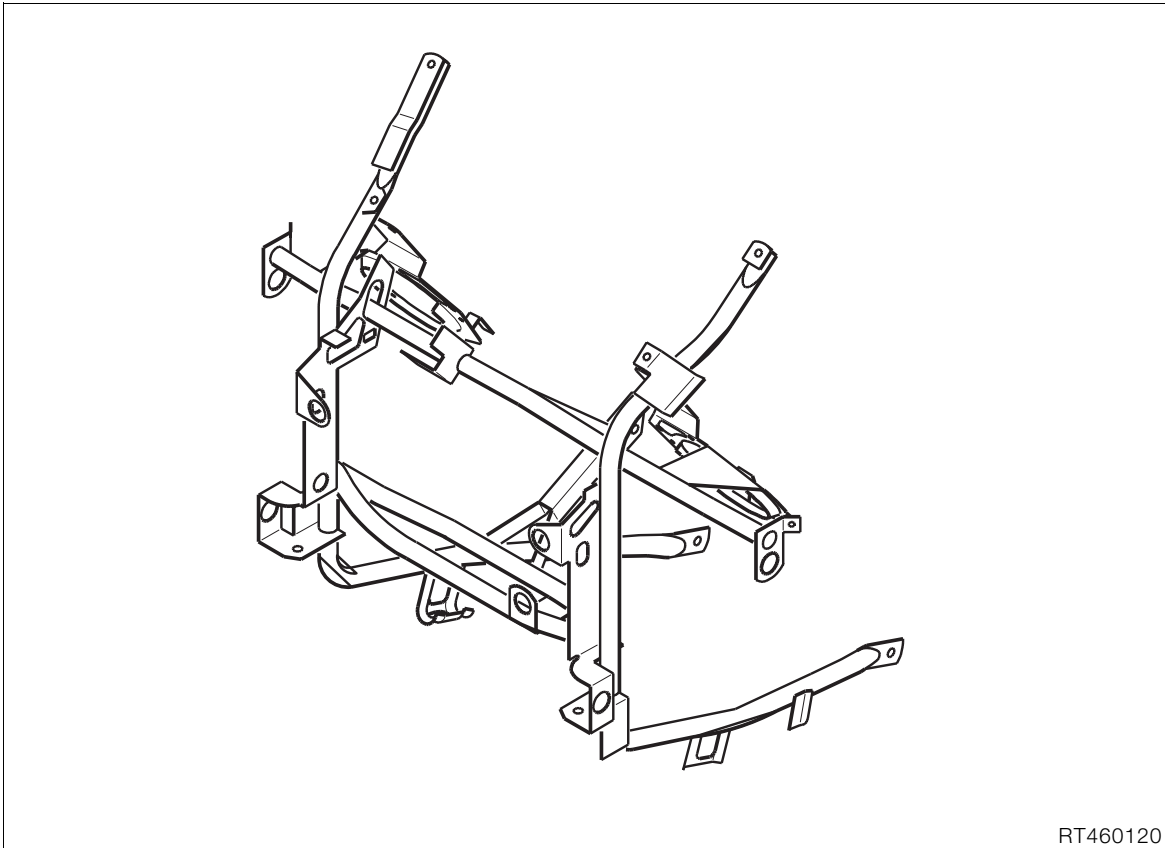

RT460120

## [RT] Removing and installing fairing holder



### Caution:

Switch off ignition.  
Disconnect ground (earth) lead from battery.  
Insulate ground (earth) lead.

- Remove dualseat.
- Remove side mirrors.
- Remove side trim panels.
- Remove inner cover for trim.
- Remove windshield.
- Remove upper section of fairing.
- Remove windshield holder.
- Detach instrument cluster.
- Remove storage compartment and air intake stub pipe.
- Detach plug strips, wiring harness and wires from fairing holder.
- Detach oil cooler mount.
- Remove trim support bracket.



### Note:

Do not scratch the mudguard when setting down the oil cooler.

- Install in the reverse order of work.



### Tightening torque:

Fairing support bracket to frame ..... 20 Nm

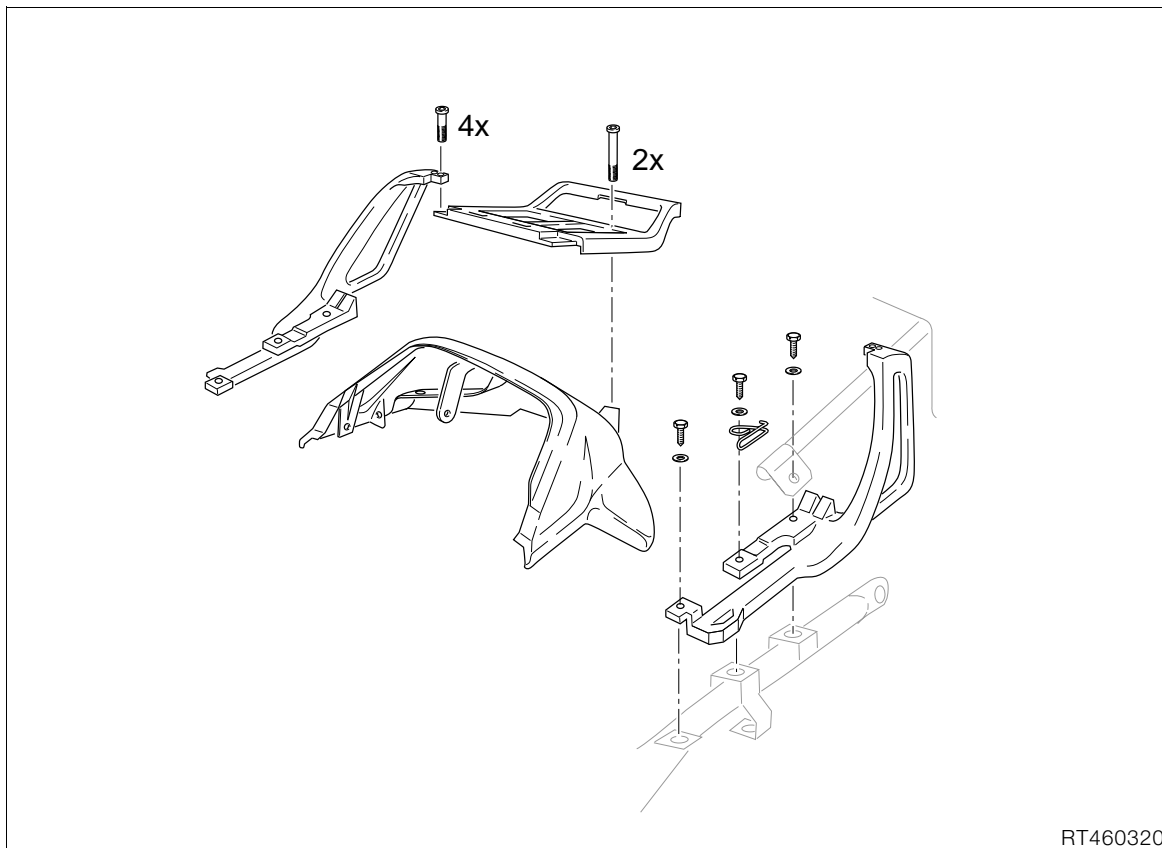

### [RT] Removing and installing luggage rack/case holder

- Remove dualseat.
- Remove luggage rack/case holder.
- Install in the reverse order of work.

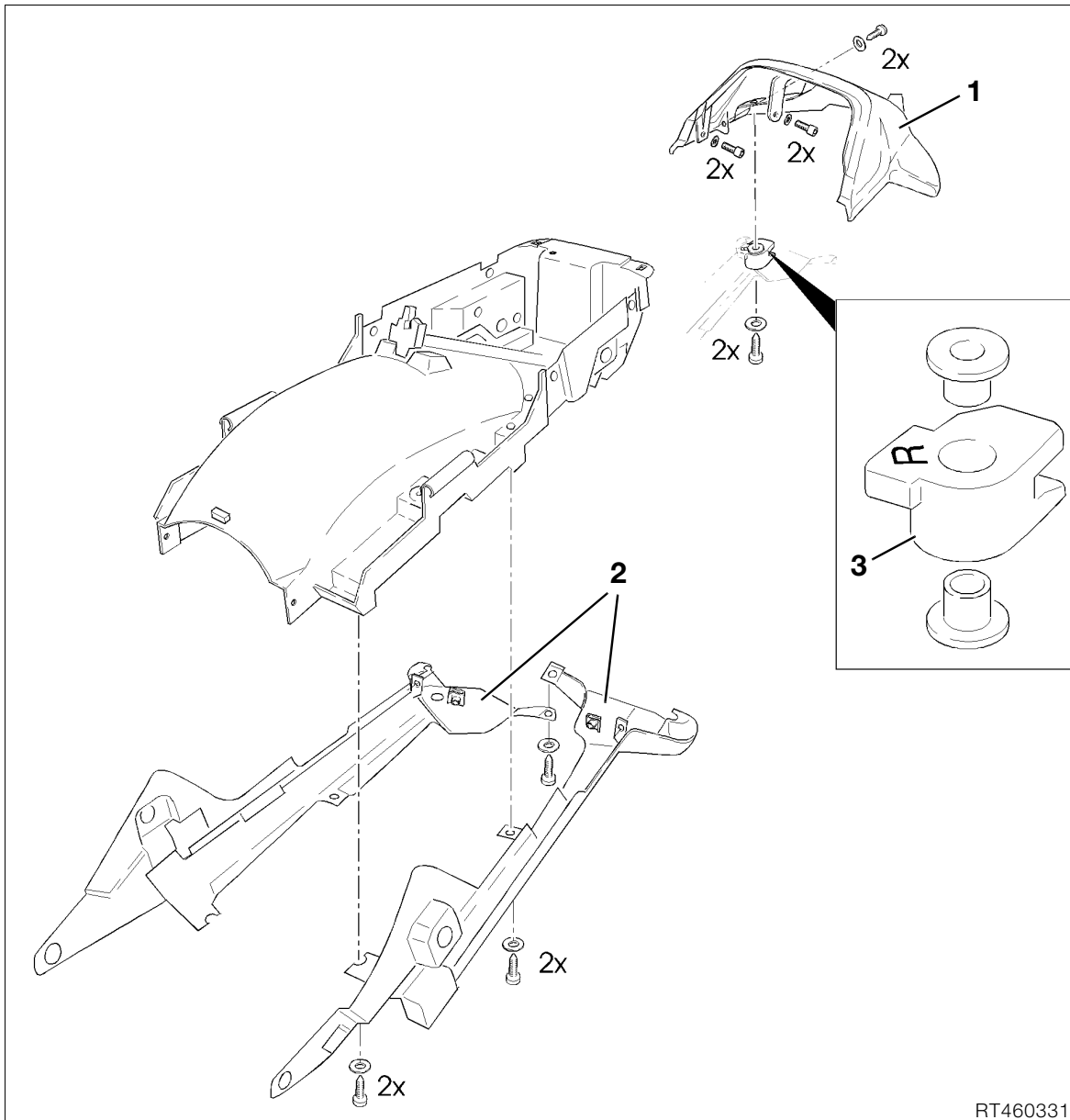

## [RT] Removing and installing rear fairing

- Remove dualseat.
- Remove small side sections of fairing.
- Remove rear light.
- Remove luggage rack and case holder.
- Remove rear fairings (1) and (2).
- Install in the reverse order of work.



### Note:

When installing, note right and left rubber buffers (3).

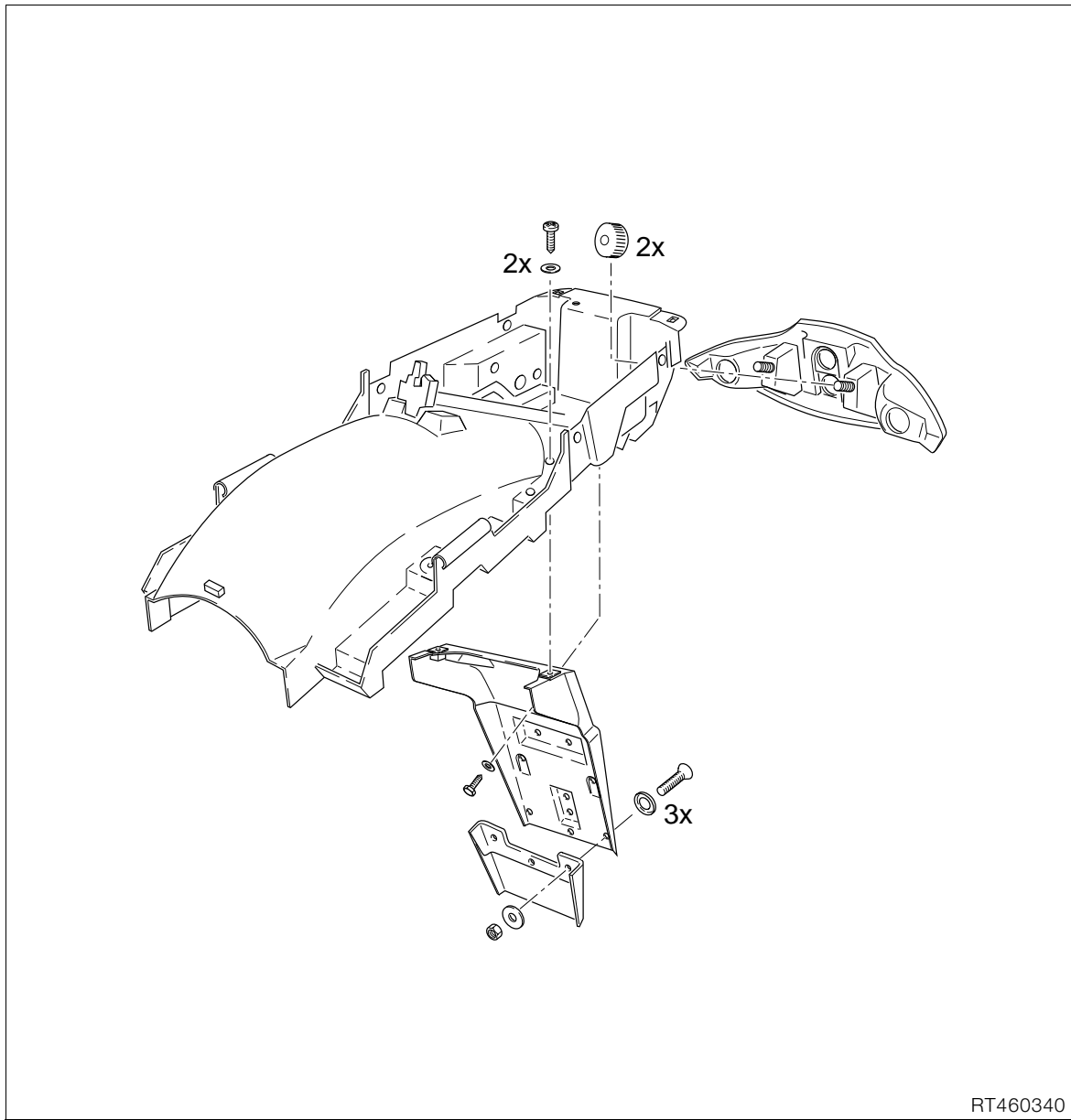

### [RT] Removing and installing number plate mount

- Remove dualseat.
- Remove number plate bracket.
- Install in the reverse order of work.



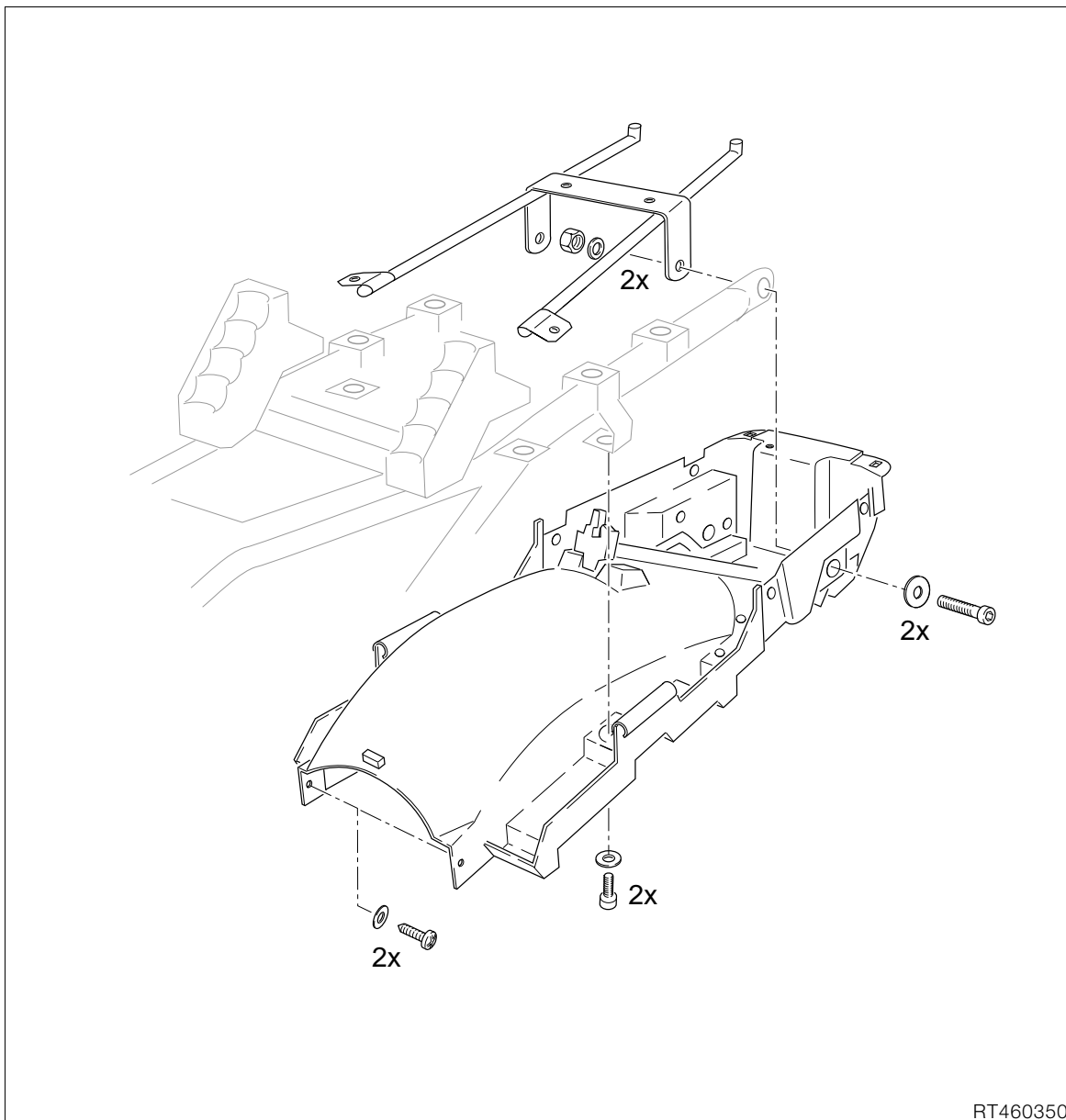

## [RT] Removing and installing lower rear section



### Caution:

Switch off ignition.  
Disconnect ground (earth) lead from battery.  
Insulate ground (earth) lead.

- Remove dualseat.
- Remove small side sections of fairing.
- Remove rear light.
- Remove luggage rack and case holder.
- Remove rear trim panel.
- Remove lower rear section.
- Install in the reverse order of work.

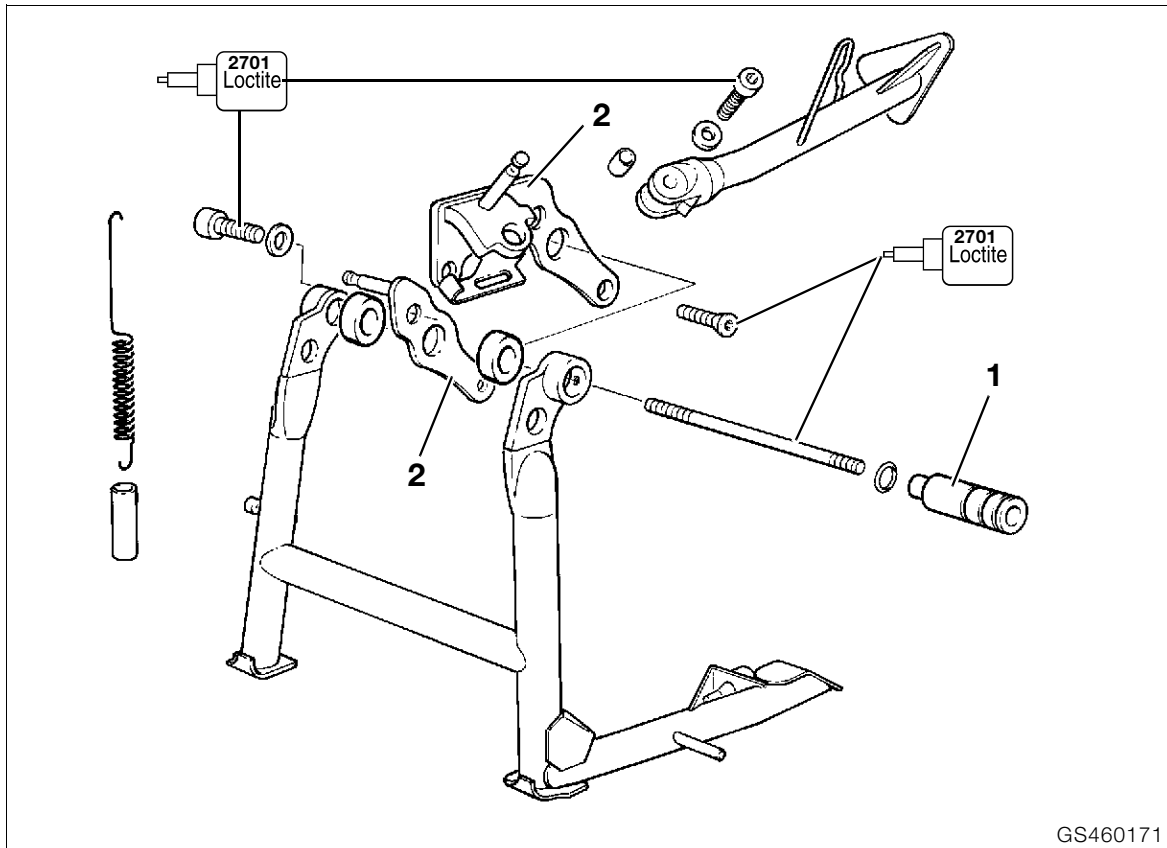

GS460171

### [RT/GS/R] Removing and installing center stand

- [GS] Remove the oil pan protection.
- [RT] Remove the fairing spoiler.

- Disconnect tension springs.
- Remove left/right pivot bushes (1).
- Remove center stand.
- Disconnect plug from side stand switch.
- Remove left/right pivot mounts (2).
- Install in the reverse order of work.

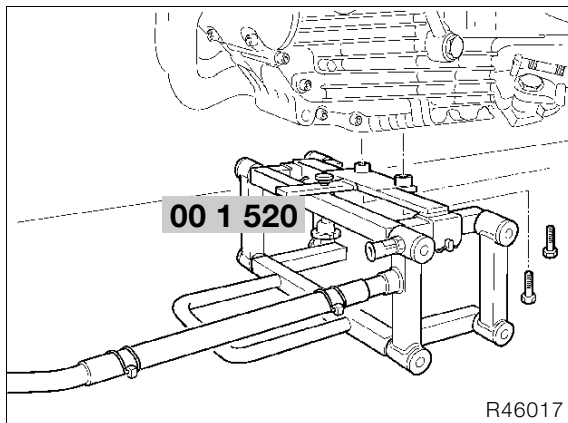

**Lubricant:**..... e.g. Staburags NBU 30 PTM

#### ! Tightening torque:

- Center stand to carrier plate  
(clean thread + Loctite 2701)..... 21 Nm
- Carrier plate to engine block, M 12  
(clean thread + Loctite 2701)..... 72 Nm
- Carrier plate at engine block, M8 countersunk screw  
(clean thread + Loctite 2701)..... 21 Nm
- Side stand to pivot mount  
(clean thread + Loctite 2701)..... 42 Nm

- Attach vehicle stand,  
**BMW No. 00 1 520**,  
[GS] with extension bushes and bolts,  
**BMW No. 00 1 527**, to motorcycle.

## Removing and installing side stand

- Disconnect tension springs.
- Remove side stand.

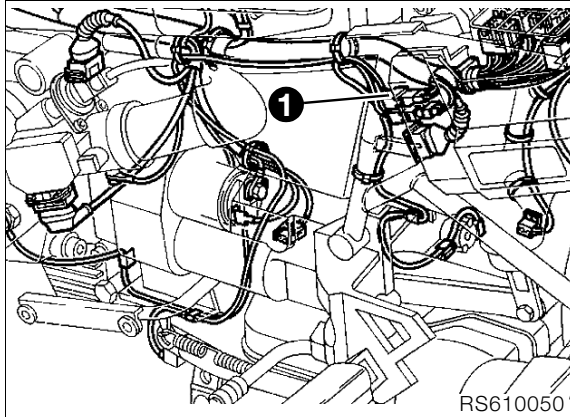

- Disconnect plug (1) from side stand switch and remove switch.
- Install in the reverse order of work.

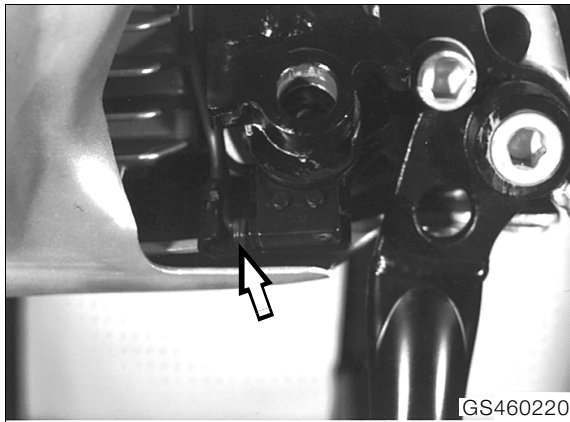

### Caution:

Note: correct cable run (arrow).

**Lubricant:**..... e.g. Staburags NBU 30 PTM



### Tightening torque:

Side stand to pivot mount  
(clean thread + Loctite 2701)..... 42 Nm

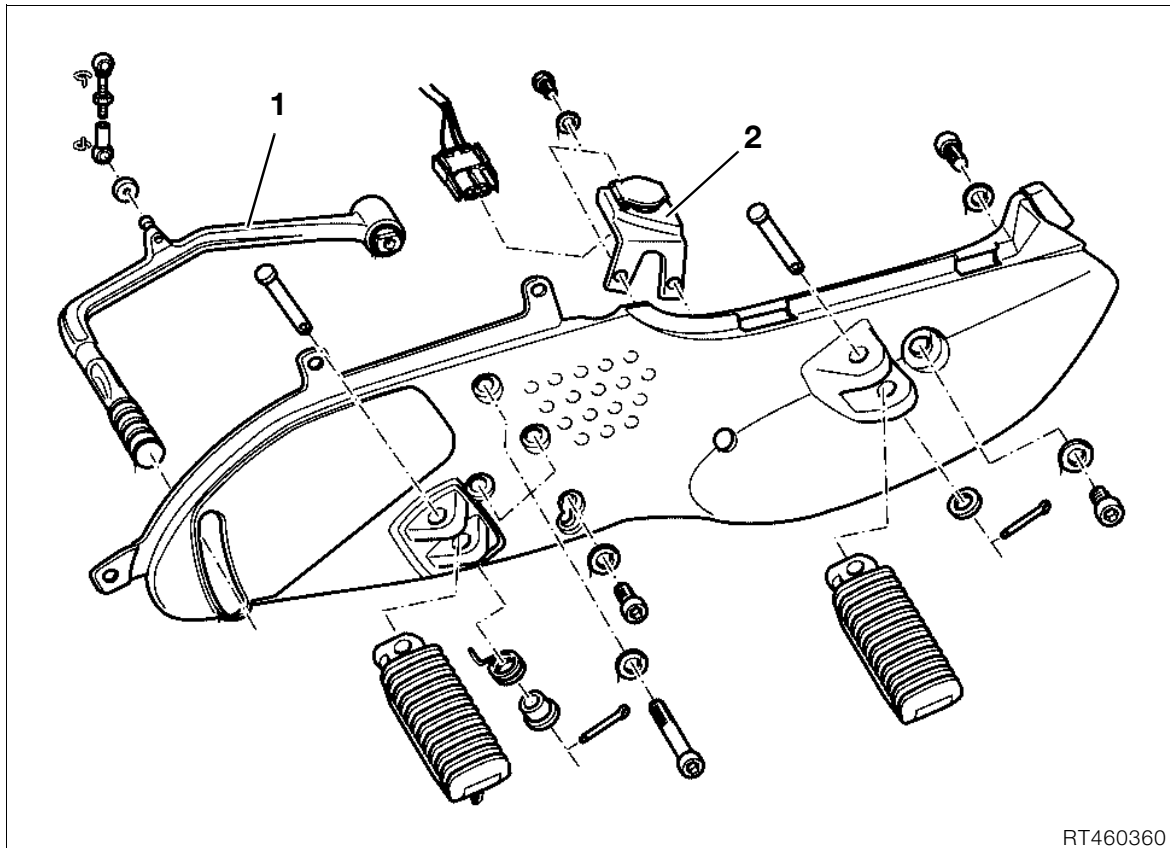

RT460360

### [RT] Removing and installing left footrest plate

- Remove dualseat.
- Remove small left side section of fairing.
- Remove left side section of fairing.
- Detach gear shift linkage (1) from footrest plate.
- Detach power socket retaining bracket (2).
- Remove the footrest plate.
- Install in the reverse order of work.



#### ! Tightening torque:

Foot pedal to footrest plate .....	18 Nm
Footrest plate to rear frame	
M 6 screw .....	6 Nm
M 8 screw .....	21 Nm
M 10 screw .....	42 Nm

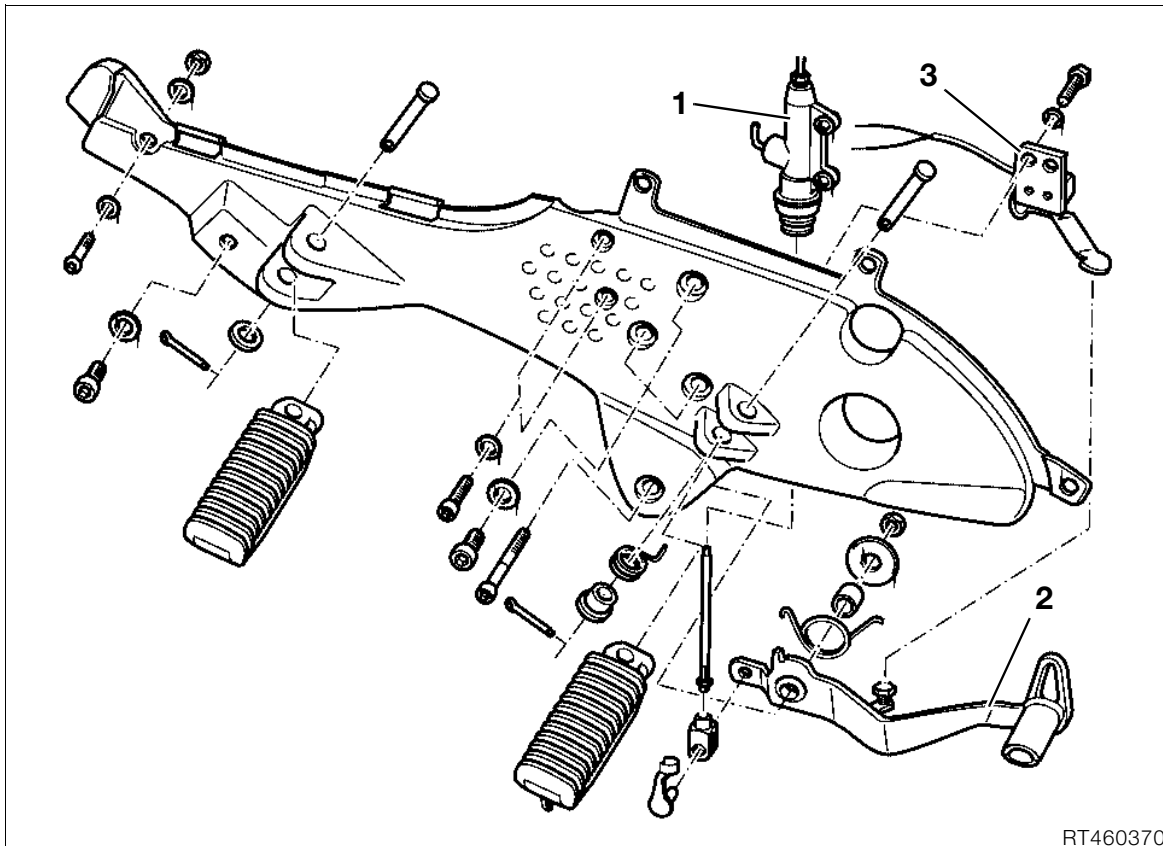

RT460370

## [RT] Removing and installing right footrest plate

- Remove dualseat.
- Remove small side section of fairing at right.
- Remove right side section of fairing.
- Release pin on brake linkage.
- Remove retaining screws for brake master cylinder (1) from footrest plate.
- Detach brake pedal (2) from footrest plate.
- Remove the footrest plate.
- Detach the contact switch (3).
- Install in the reverse order of work.



### ! Tightening torque:

Footrest plate to rear frame	
M 6 screw .....	6 Nm
M 8 screw .....	21 Nm
M 10 screw .....	42 Nm

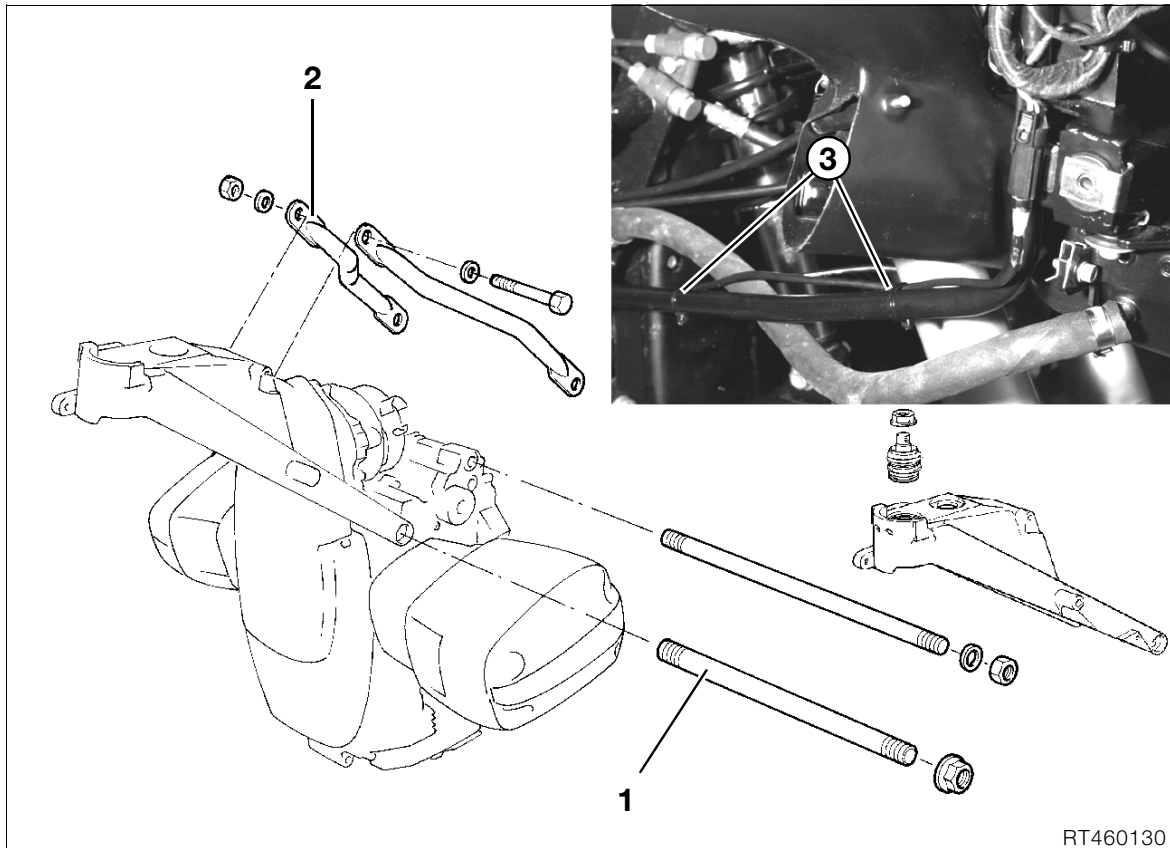

RT460130

## [RT] Removing and installing frame

- Remove fuel tank.
- Detach handlebar from fork bridge.
- Detach fixed tubes at fork bridge.
- Remove fork bridge.



### Note:

Before removal, heat the bearing point to max. 120°C. The screw pin is a press fit in ball thrust bearing: remove complete unit.

- Detach brake line from frame/open the lines.
- Remove the horn.
- Remove front suspension strut.
- Detach ball joint at front of leading link.
- Pull the leading link up and secure it with a strap.
- Unscrew pin (1) from engine and remove.
- Open cable strap (3) for ABS sensor line at fairing holder.
- Detach fairing holder from frame.



### Caution:

Fairing section will drop unless held securely. If necessary, place foam rubber or similar material below fairing panel.

- Detach struts (2) from frame and loosen at engine.
- Remove frame.
- Install in the reverse order of work.
- Pull the leading link up and secure with a strap.



### Tightening torque:

Leading link at ball joint (clean thread + Loctite 2701).....	130 Nm
Fork bridge to frame (clean thread + Loctite 243).....	130 Nm
Frame to engine .....	82 Nm
Struts to frame (10.9 screw) .....	58 Nm
Struts to engine.....	58 Nm
Fairing support bracket to frame .....	20 Nm

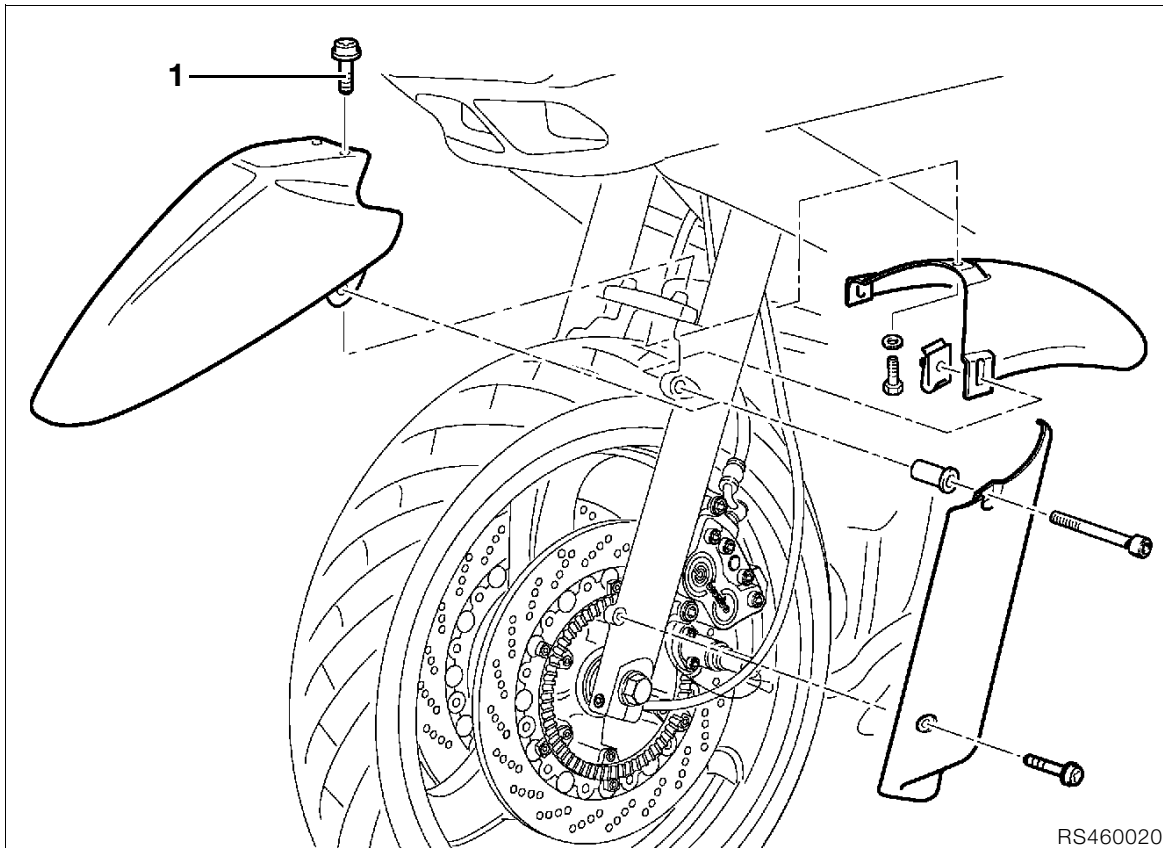

## [RS] Removing and installing front mudguard



**Note:**

Retaining screw (1) = 3 mm (0.118 in) Allen screw.

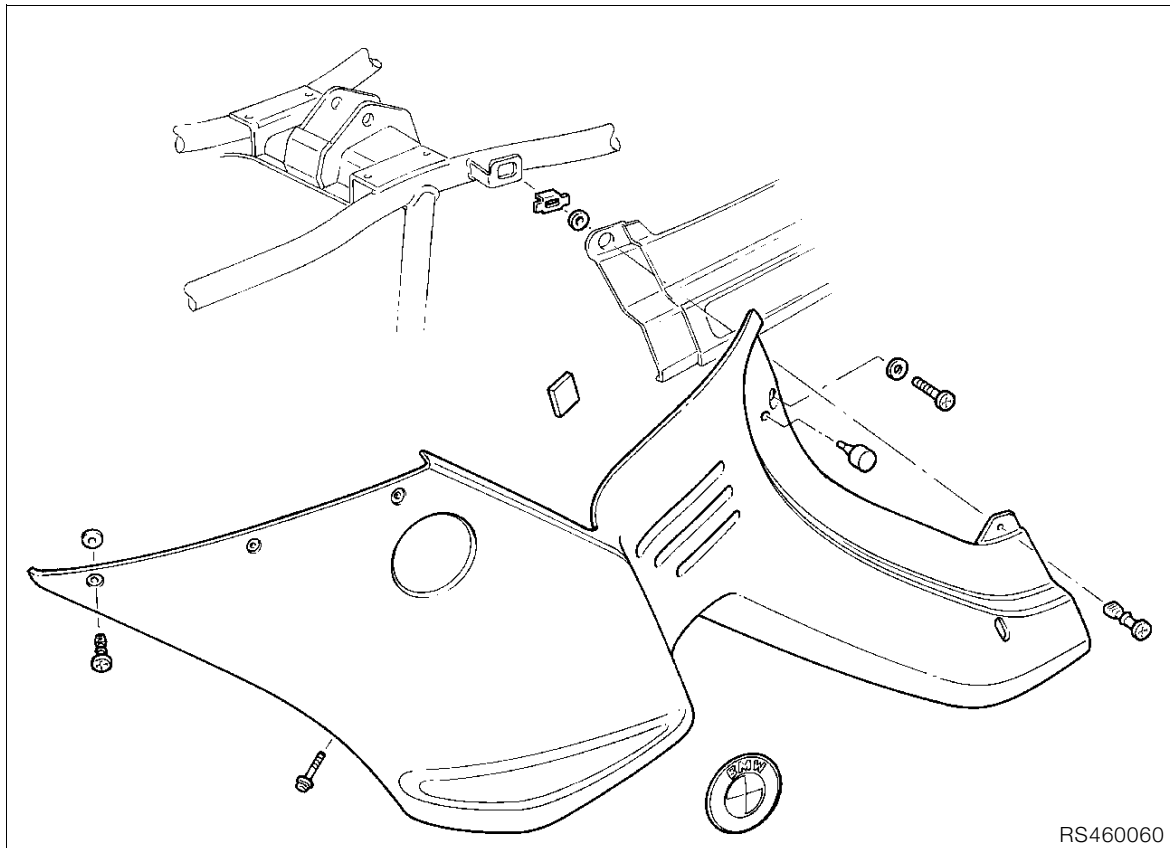

**[RS] Removing and installing side sections of fairing**



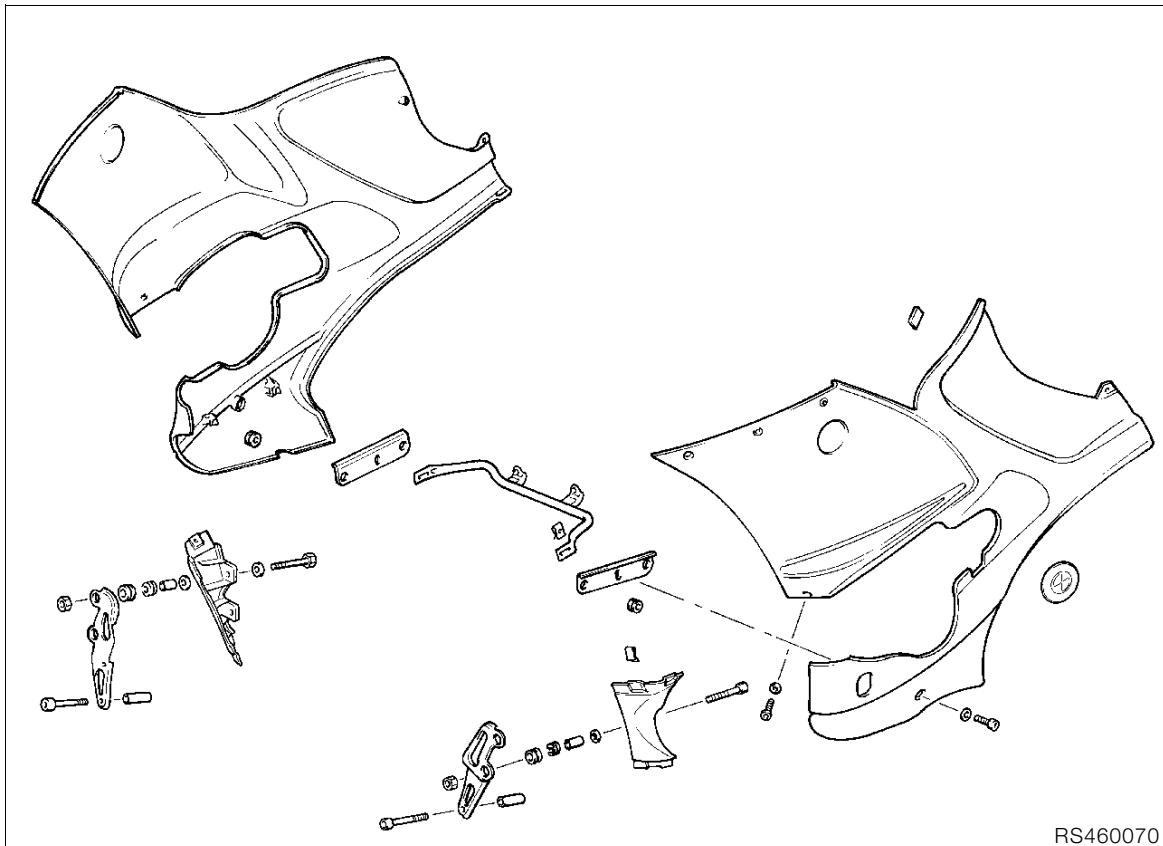

**[RS] Removing and installing side sections of full fairing**

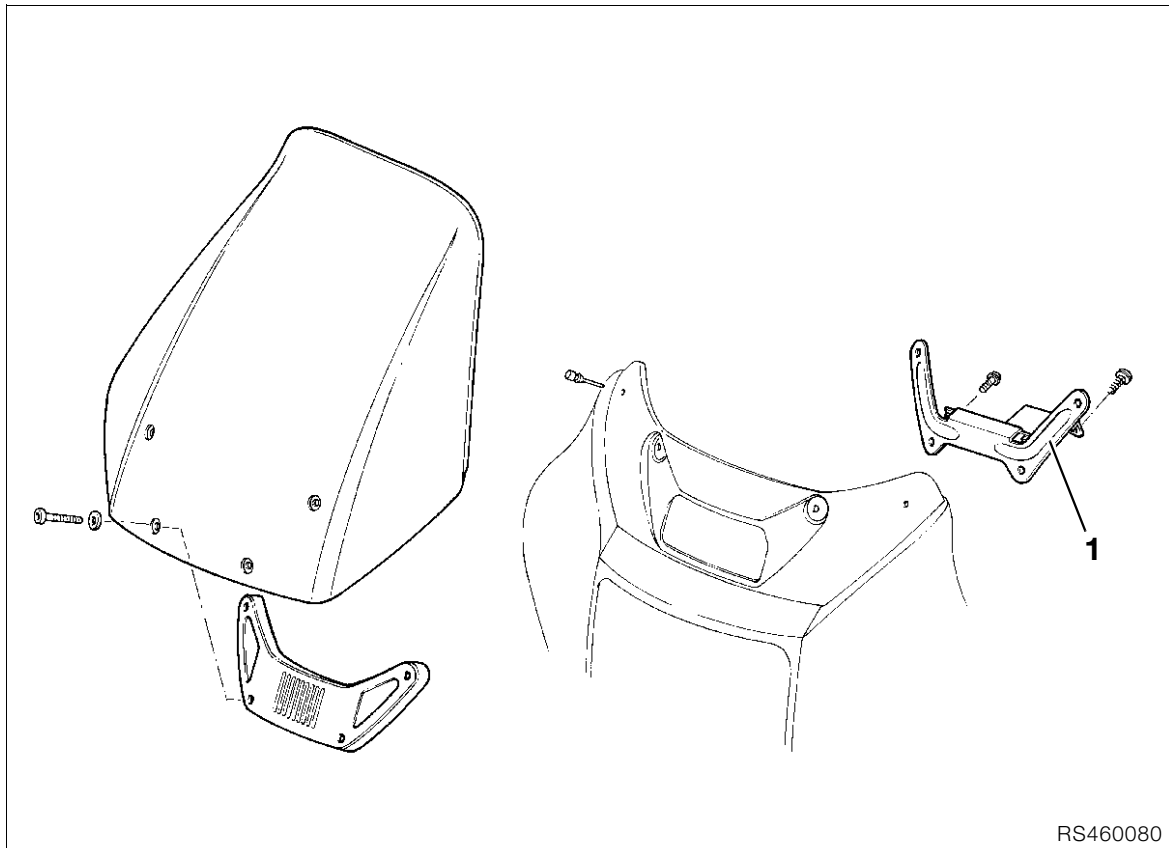

### [RS] Removing and installing windshield

- Remove windshield.
- Remove front side sections of fairing.
- Remove inner fairing cover.
- Detach instrument cluster.
- Detach top section of fairing.
- Remove headlight.
- Remove bracket (1) for windshield.
- Install in the reverse order of work.

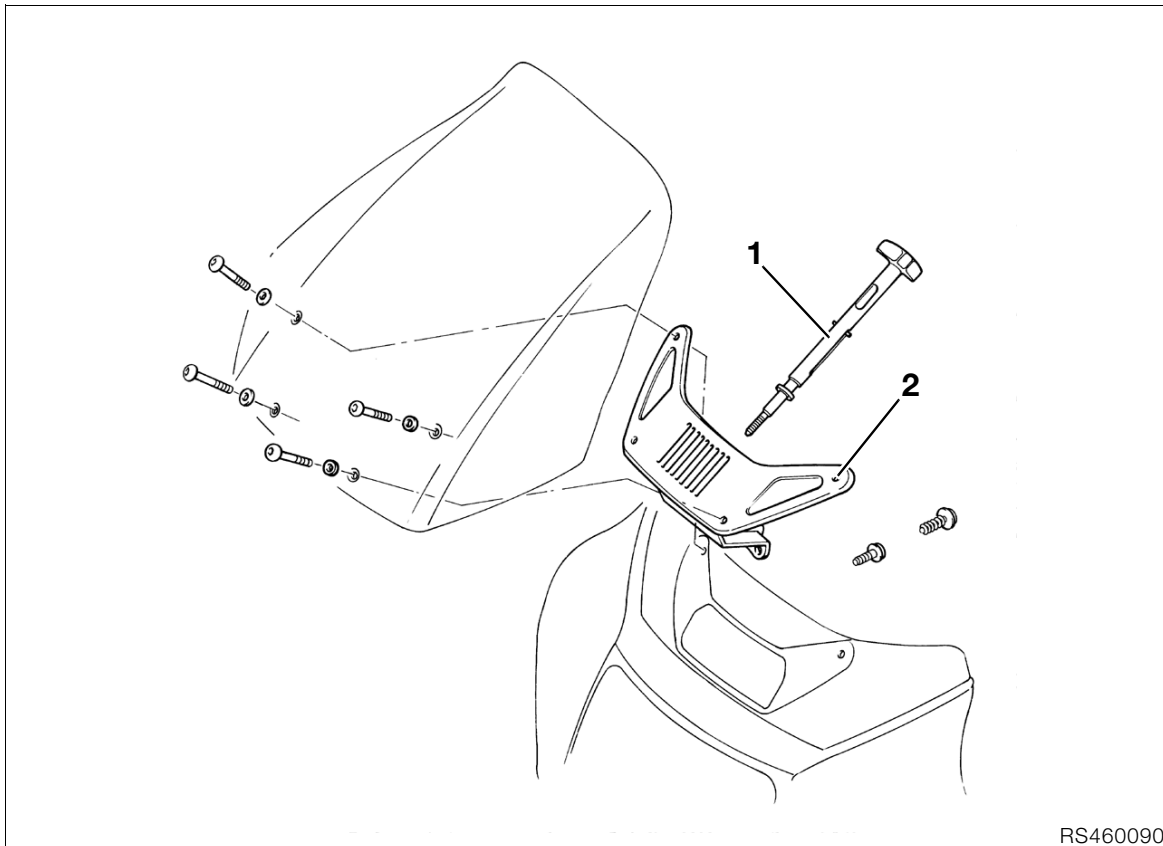

RS460090

### [RS] Removing and installing adjustable windshield

- Remove windshield.
- Remove side sections of fairing.
- Remove inner fairing panel.
- Turn adjusting shaft (1) counterclockwise to unfasten.
- Detach instrument cluster.
- Detach top section of fairing.
- Remove headlight.
- Remove bracket (2) for windshield.
- Install in the reverse order of work.

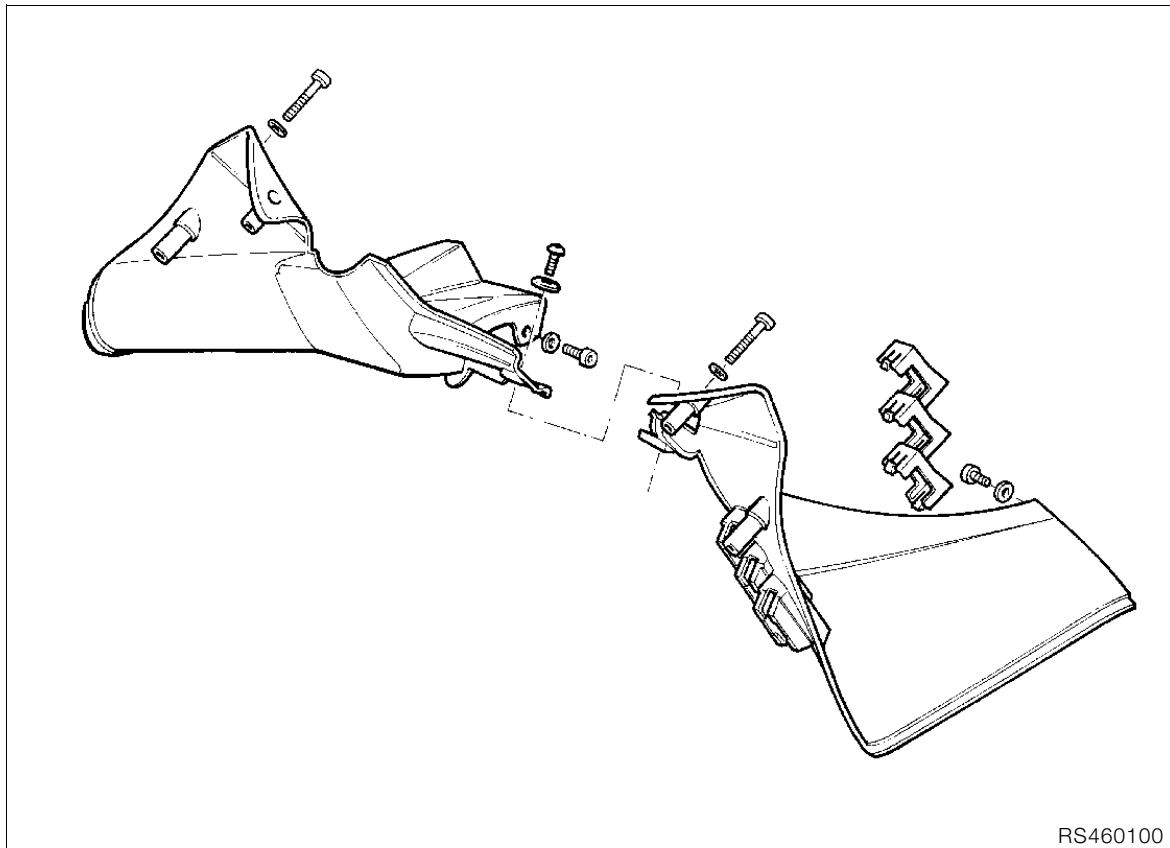

RS460100

**[RS] Removing and installing inner  
fairing panel**

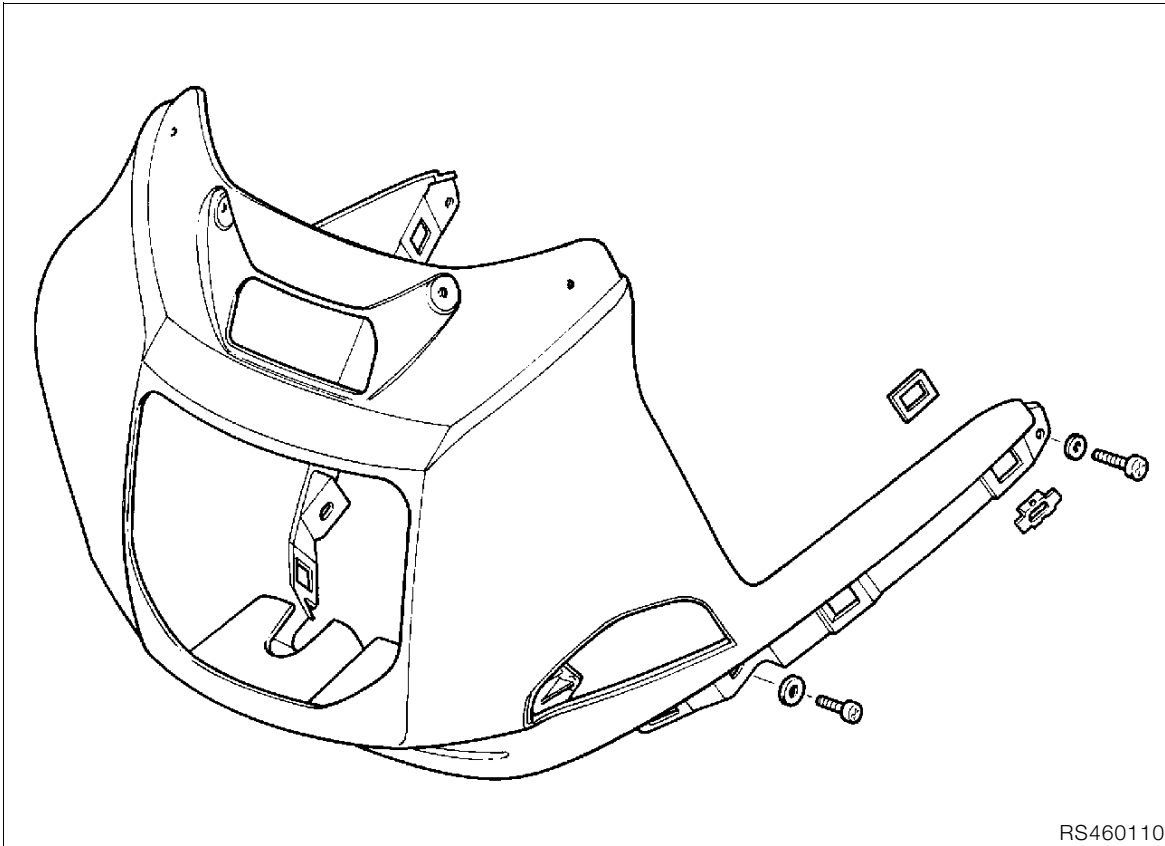

### [RS] Removing and installing top section of fairing



**Caution:**

Switch off ignition.  
Disconnect ground (earth) lead from battery.  
Insulate ground (earth) lead.

- Remove windshield.
- Remove side sections of fairing.
- Remove inner fairing panel.
- Unscrew and remove windshield adjusting shaft.
- Detach instrument cluster.
- Detach plug connections for flashing turn indicators.
- Detach top section of fairing.
- Remove headlight.
- Remove bracket for windshield.
- Remove fairing.
- Install in the reverse order of work.

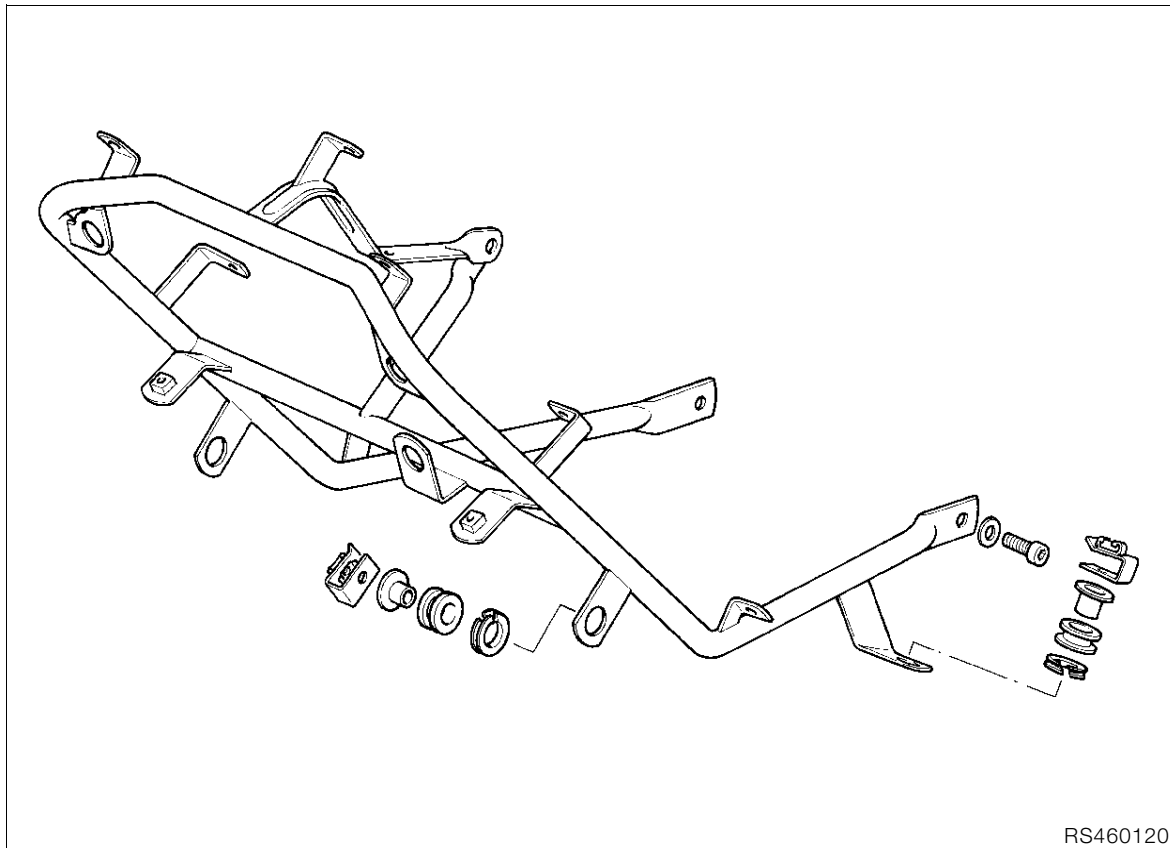

## [RS] Removing and installing fairing holder



### Caution:

Switch off ignition.  
 Disconnect ground (earth) lead from battery.  
 Insulate ground (earth) lead.

- Remove side sections of fairing.
- Remove inner fairing panel.
- Turn adjusting shaft counterclockwise to release windshield adjuster.
- Detach instrument cluster.
- Separate plug connectors for headlights and indicators.
- Remove top section of fairing with headlight.
- Detach connector strip and wiring harness from fairing holder.
- Detach oil cooler mount.
- Install in the reverse order of work.



### Tightening torque:

Fairing support bracket to frame ..... 20 Nm

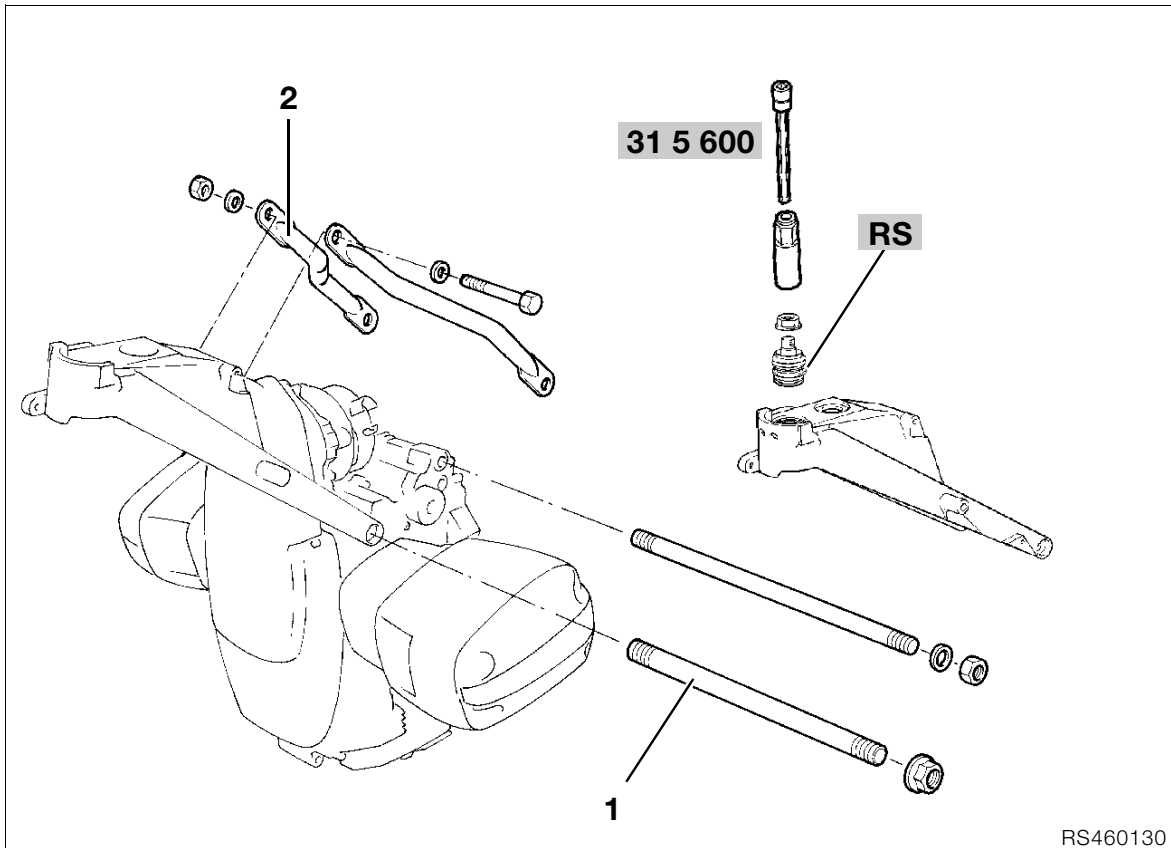

## Removing and installing frame

- Remove fuel tank.
- Detach brake line from frame.
- **[RS/GS]** Detach fairing holder at frame.

### Caution:

Fairing will drop unless held securely.  
If necessary, place foam rubber or similar material below fairing panel.

- Detach ball joint at front of control arm and pull telescopic fork forwards.
- Detach front suspension strut at top.
- Unscrew pin (1) from engine and remove.
- Screw the ball joint on handtight at the front of the leading link.
- Detach struts (2) from frame and loosen at engine.
- **[RS]** Using socket wrench insert with 6 mm (0.2362 in) Allen key, **BMW No. 31 5 600**, detach ball joint at fork bridge.
- **[R]** Detach handlebar from fork bridge.
- **[R]** Pull headlight holder forwards.
- Unfasten screw connection between fork bridge and frame.



### Note:

Screw pin is a press fit in ball thrust bearing: remove complete unit.

- **[R]** Detach oil cooler holder.
- Remove frame.
- Install in the reverse order of work.



### Tightening torque:

Frame to engine .....	82 Nm
Struts to frame (8.8 screw) .....	47 Nm
(10.9 screw) .....	58 Nm
Struts to engine <b>[RS]</b> .....	47 Nm
<b>[GS/R]</b> .....	58 Nm
Fairing support bracket to frame .....	20 Nm

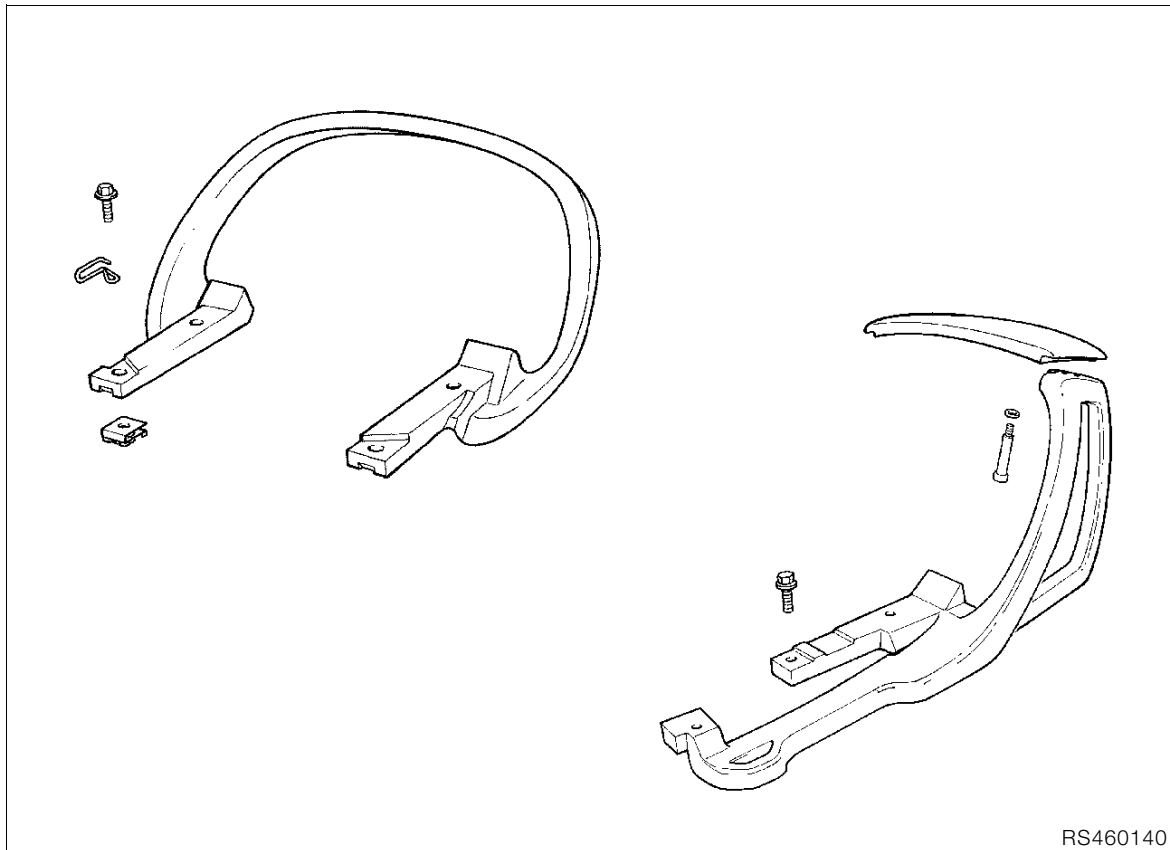

### [RS] Removing and installing grab handle/case holder

 **Tightening torque:**  
Grab handle to rear frame ..... 9 Nm



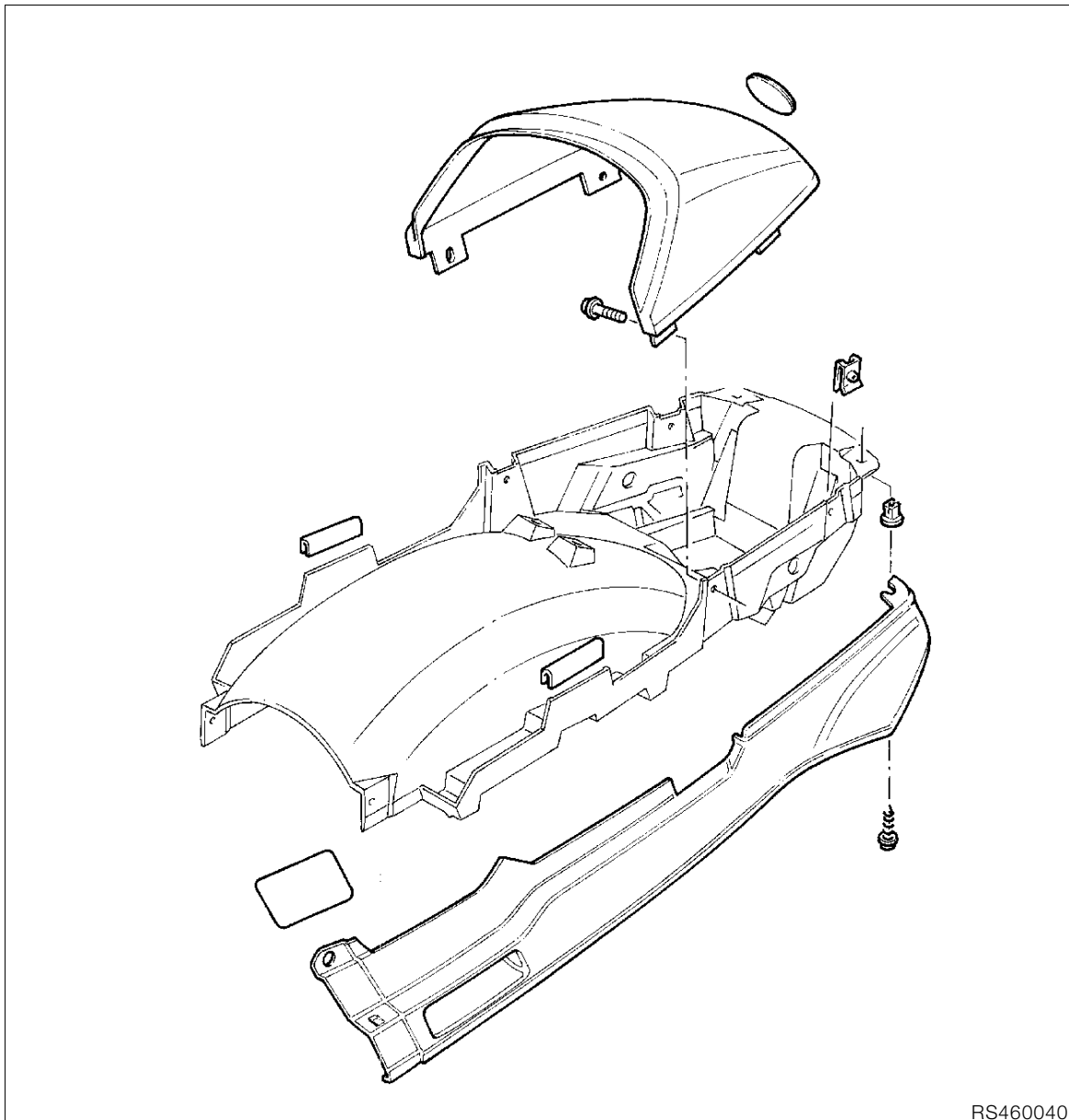

RS460040

### [RS] Removing and installing rear fairing

- Remove dualseat.
- Remove rear light.
- Remove rear fairing panel.
- Install in the reverse order of work.

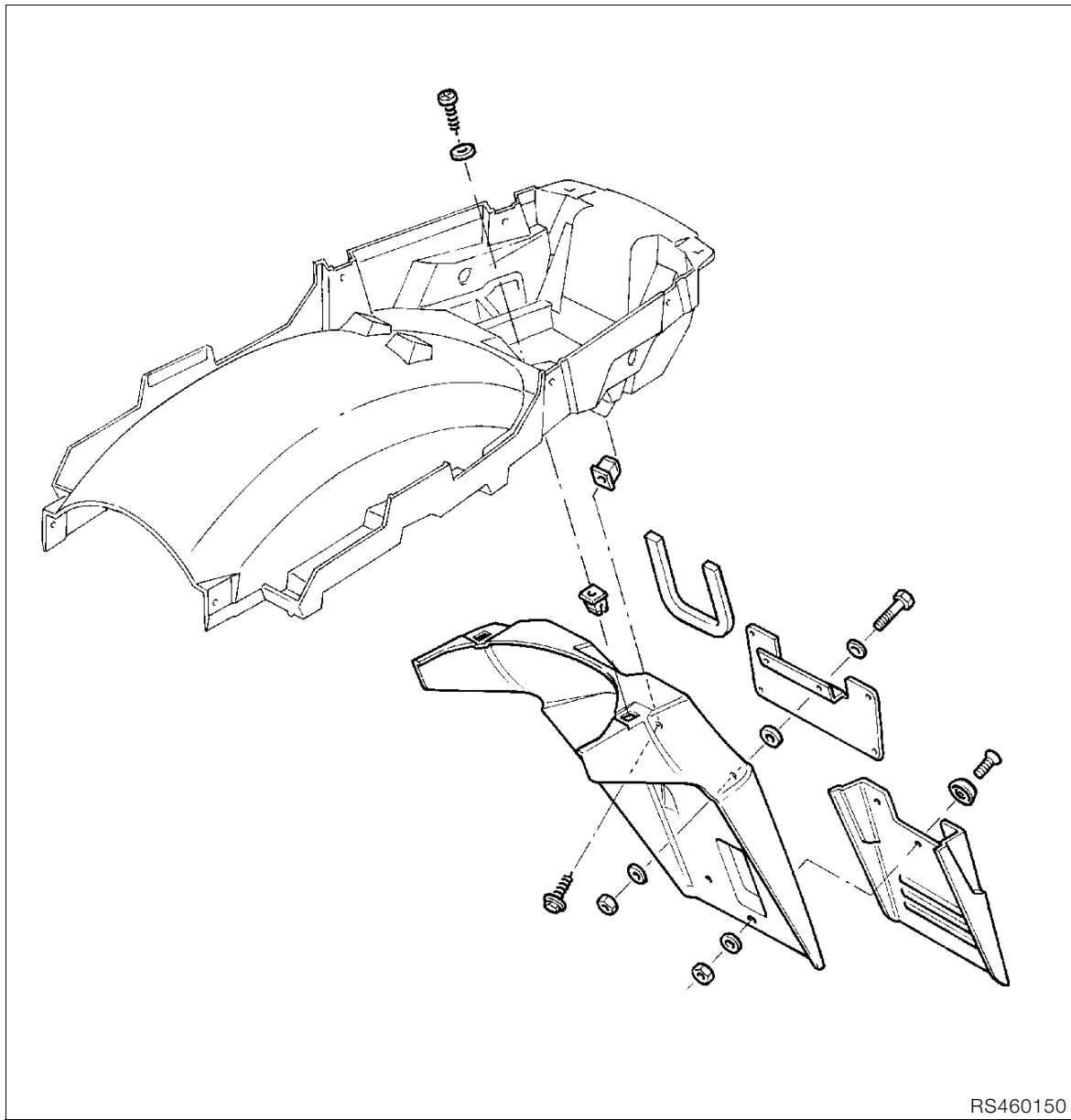

### [RS] Removing and installing number plate bracket

- Remove dualseat.
- Remove number plate bracket.
- Install in the reverse order of work.

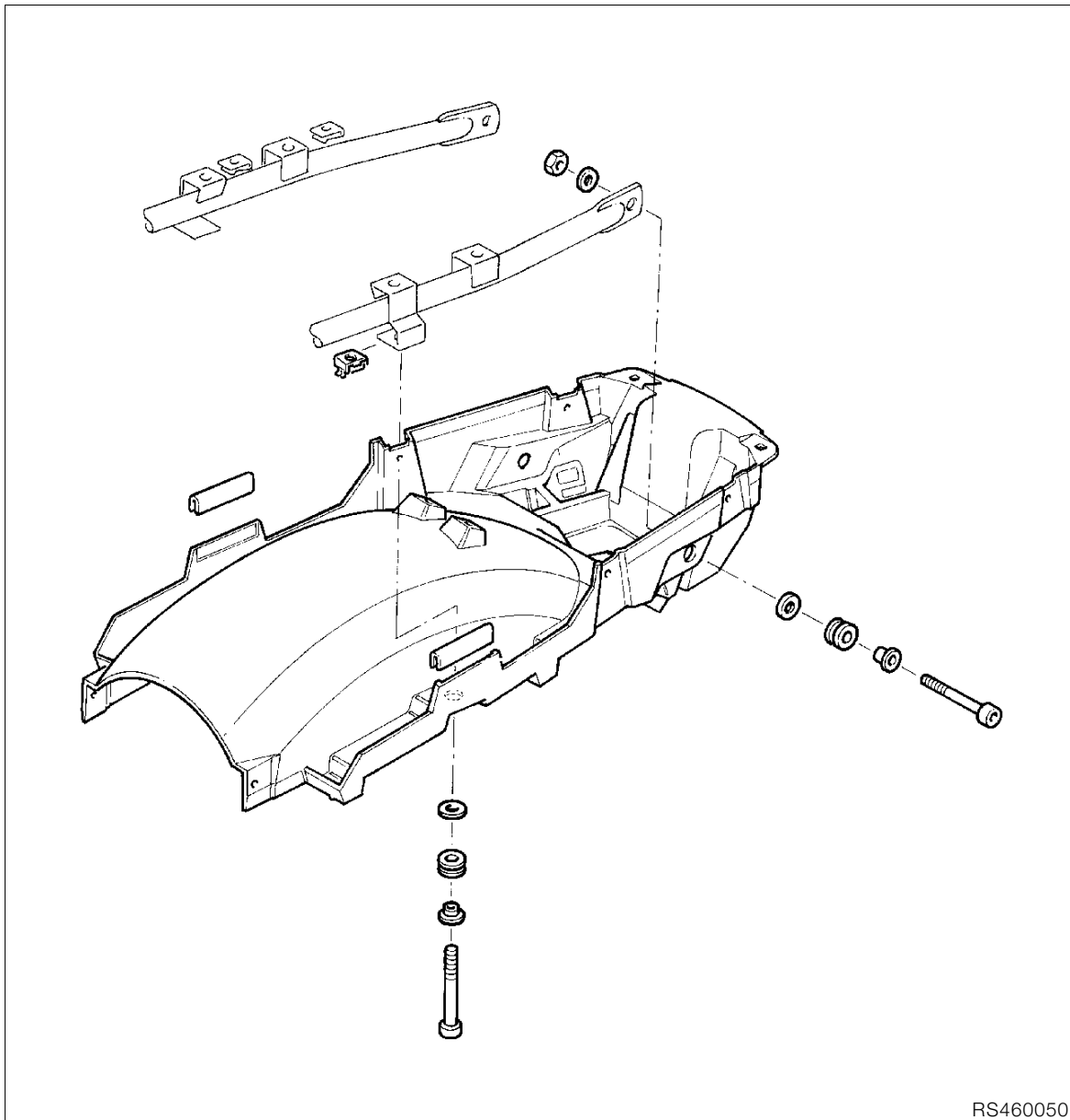

RS460050

## [RS] Removing and installing lower rear section



### Caution:

Switch off ignition.  
Disconnect ground (earth) lead from battery.  
Insulate ground (earth) lead.

- Remove dualseat.
- Remove number plate bracket.
- Remove rear light.
- Remove rear fairing.
- Remove turn indicator lenses.
- Disconnect/detach turn indicators.
- Detach wiring harness from lower rear section.
- Remove dualseat lock.
- Remove lower rear section.
- Install in the reverse order of work.

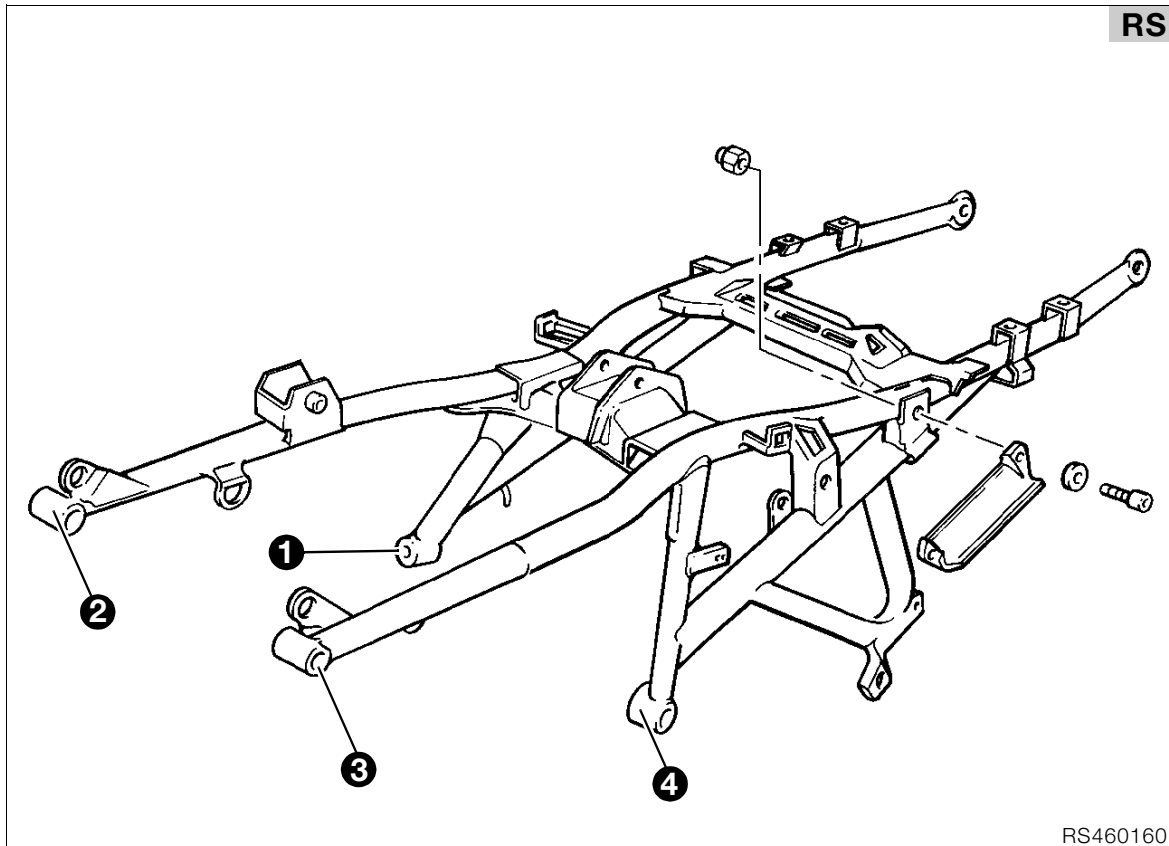

RS460160

## Removing and installing rear section of frame



### Caution:

Switch off ignition.  
Disconnect ground (earth) lead from battery.  
Insulate ground (earth) lead.

- Remove dualseat.
- **[RT]** Remove mirrors.
- **[RT]** Remove side sections of fairing.
- Remove fuel tank.
- **[GS/RT]** Remove luggage rack.
- **[GS/RT]** Detach wiring harness at rear section of frame/detach central electrical equipment box only.
- **[RS/R/RT]** Remove rear light.
- **[RS/R/RT]** Remove rear fairing.
- **[RS/R/RT]** Detach wiring harness from left turn indicator to central electrical equipment box/detach central electrical equipment box only.
- **[RS/R/RT]** Remove lower rear section.
- **[ABS]** Separate the ABS sensor plug and detach the cable.
- Disconnect the brake light switch plug and detach the cable.
- Disconnect the side stand switch plug and detach the cable.

- Disconnect the neutral switch plug and detach the cable.
- Detach diagnosis plug and cable.
- Pull brake cable out of holder/rear section of frame.
- Pull brake fluid container out of holder.
- Detach muffler (silencer) from rear section of frame.
- Detach upper suspension strut mount.
- **[RT]** Detach footrest plates from rear section of frame.
- Remove air cleaner box from rear section of frame.
- Remove rear section of frame.
- Remove fittings.
- Install in the reverse order of work.

### Tightening sequence:

1. Screw connection ..... on right of gearbox
2. .... on right of engine
3. .... on left of engine
4. .... on left of gearbox



### Tightening torque:

Rear section of frame to gearbox/engine ..... 47 Nm

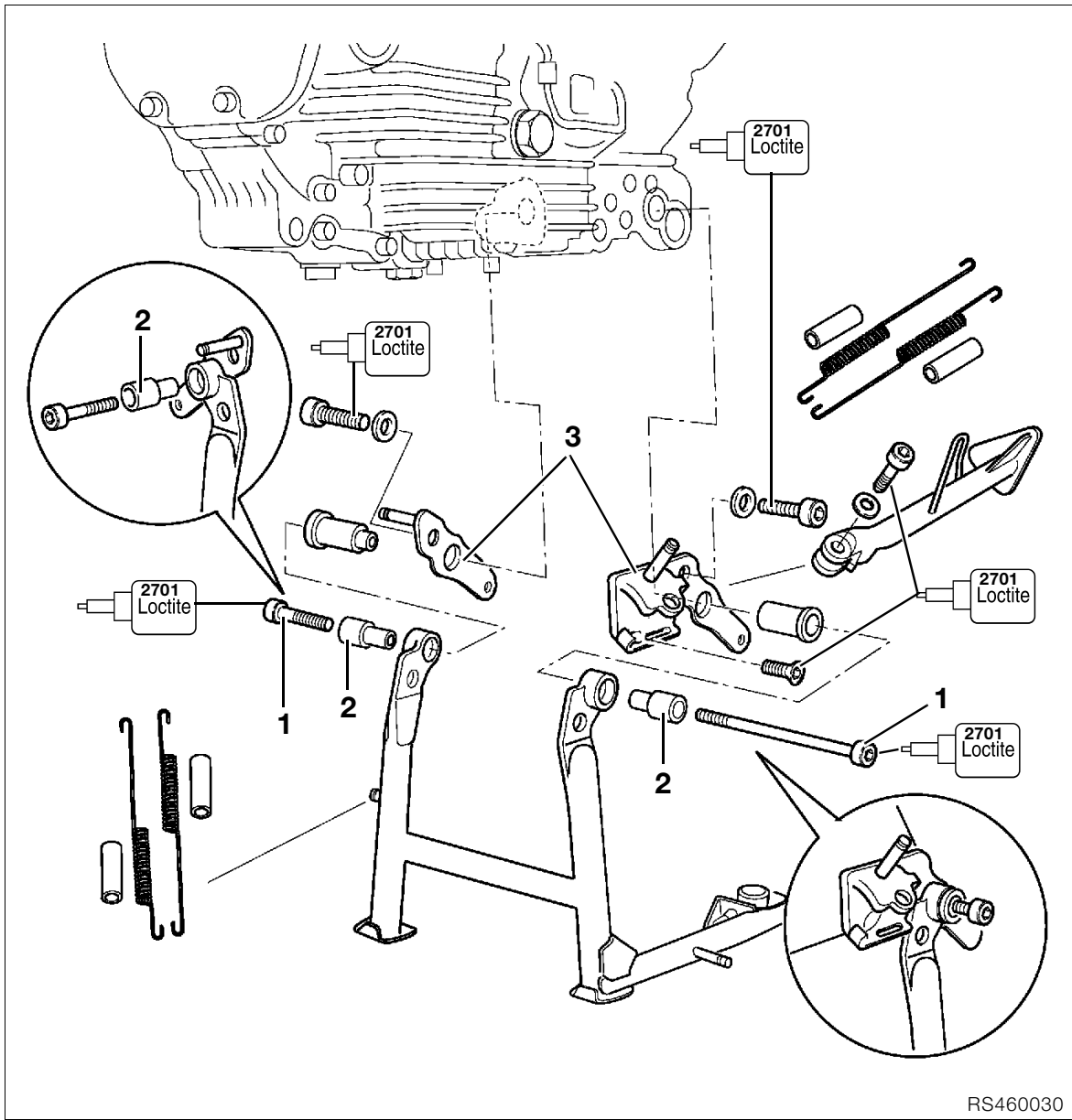

**[RS] Removing and installing center stand**

- Remove lower section of fairing.

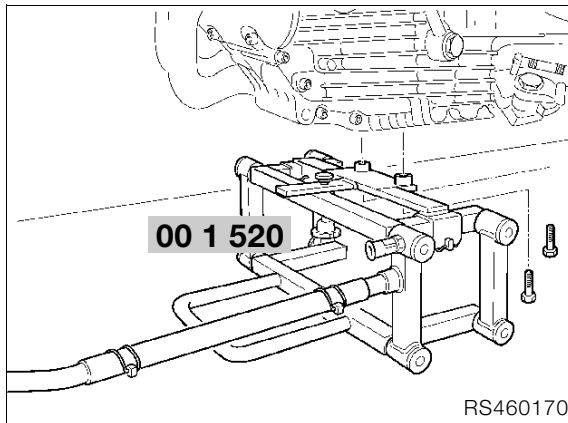

- Raise the motorcycle with stand, **BMW No. 00 1 520**.
- Disconnect tension springs.
- Unfasten left/right retaining screws (1).
- Take out pivot bushes (2) together with M10 screw.
- Remove center stand.
- Disconnect plug from side stand switch.
- Remove left/right bearing mount (3).
- Install in the reverse order of work..



**Lubricant**..... e.g. Staburags NBU 30 PTM

 **Tightening torque:**

- Center stand to carrier plate  
(clean thread + Loctite 2701)..... 21 Nm
- Carrier plate to engine block, M 12  
(clean thread + Loctite 2701)..... 72 Nm
- Carrier plate at engine block, M 8 countersunk  
screw (clean thread + Loctite 2701) ..... 21 Nm
- Side stand at bearing mount  
(clean thread + Loctite 2701)..... 42 Nm



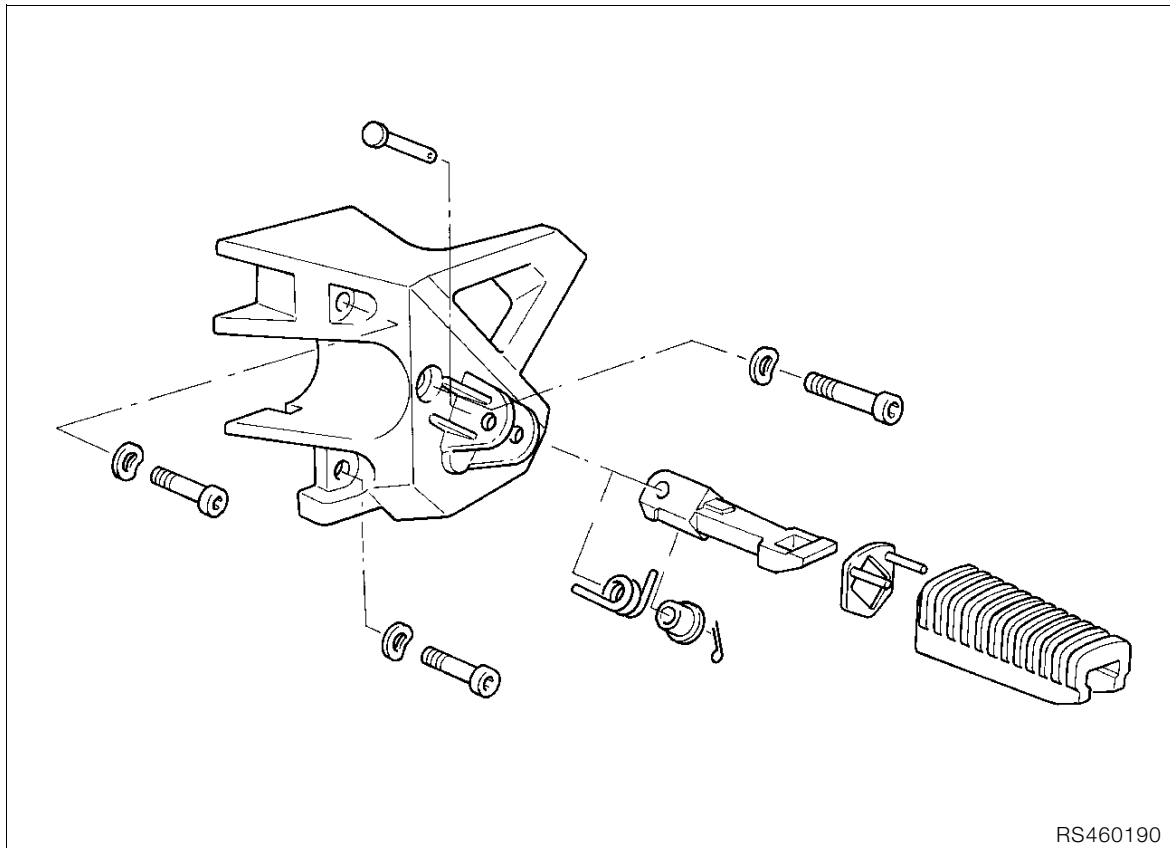

## [RS/R] Removing and installing front footrest plate

**! Tightening torque:**

Footrest plate to gearbox .....	22 Nm
Master cylinder to footrest plate .....	7 Nm
Brake pedal to footrest plate .....	37 Nm



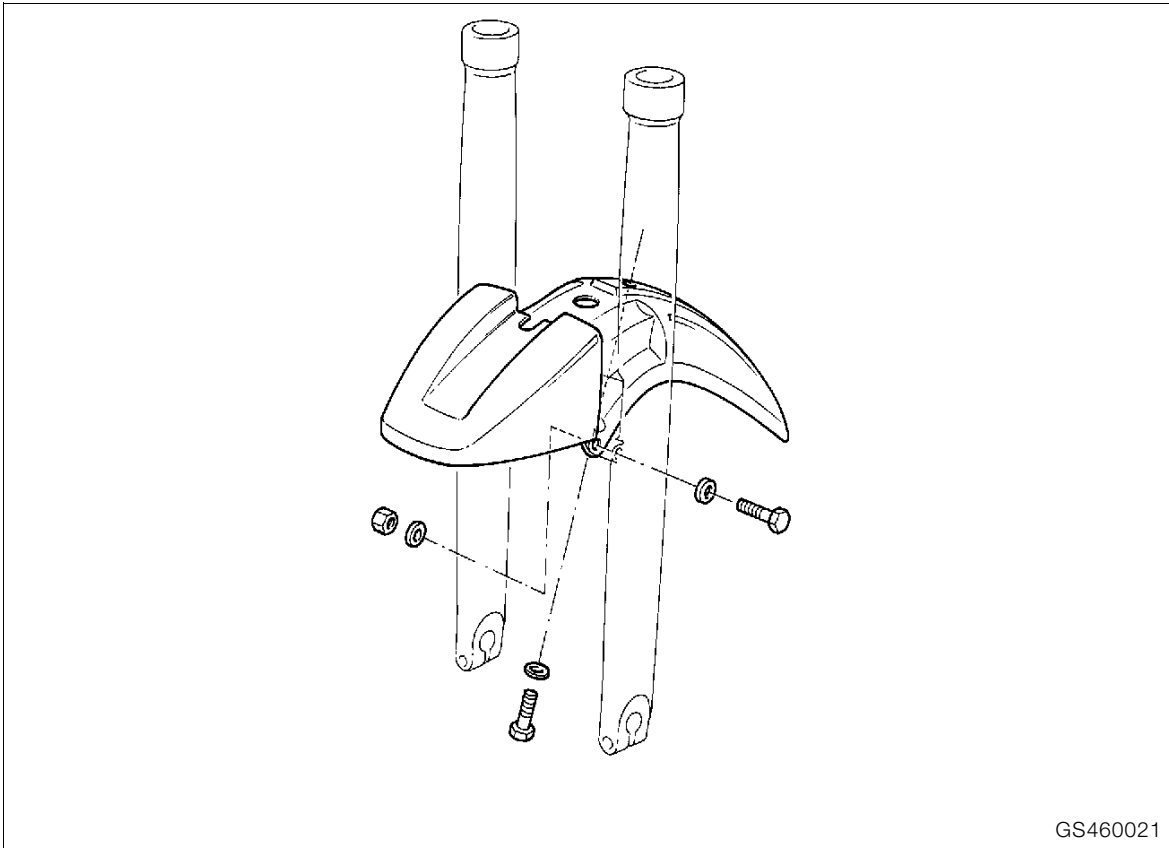

GS460021

### [GS/R] Removing and installing front mudguard

- Remove front wheel.

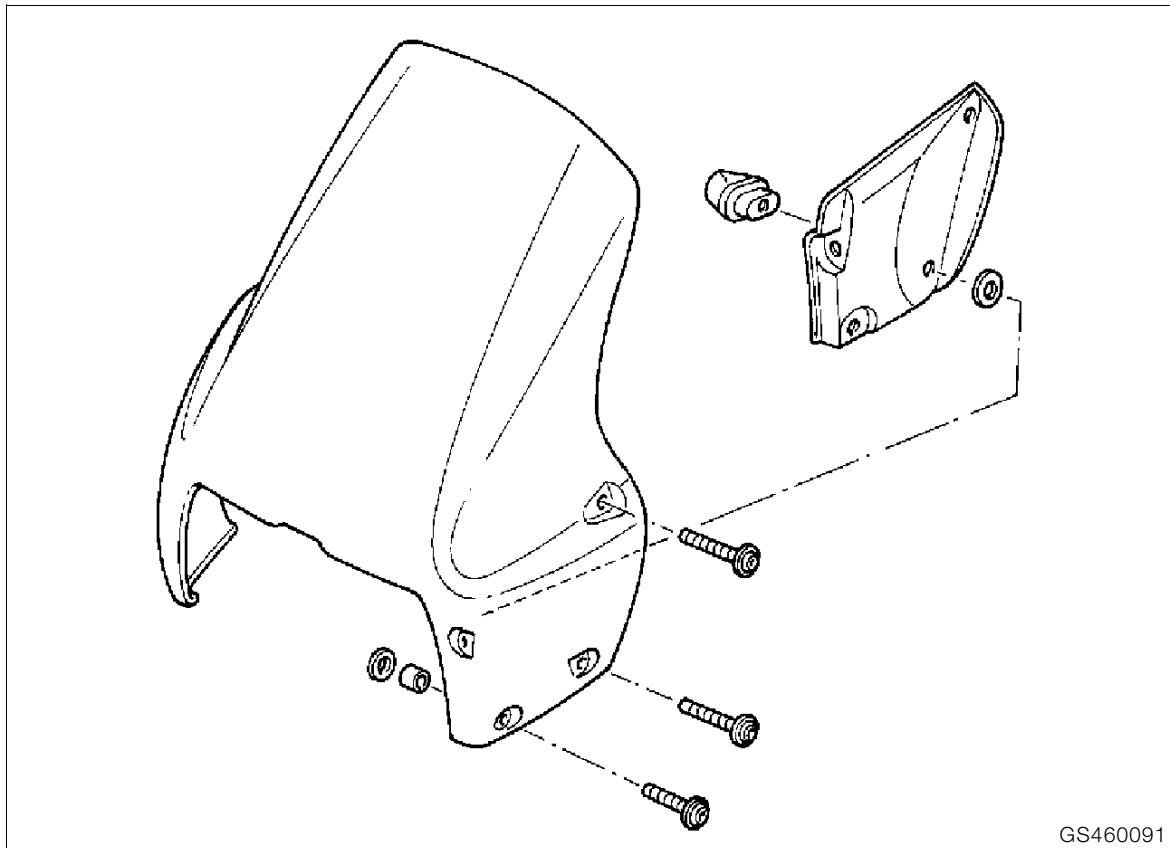

GS460091

**[GS] Removing and installing  
windshield**

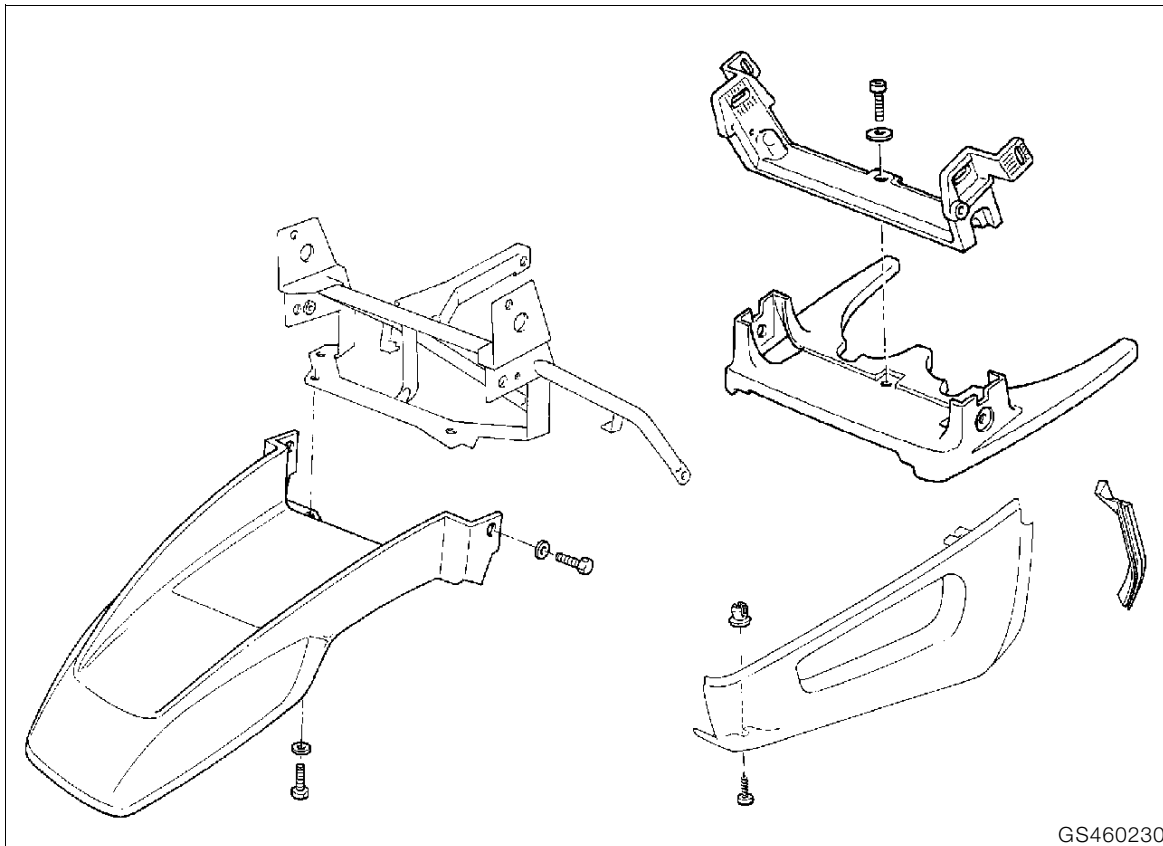

GS460230

## [GS] Removing and installing front fairing



### Caution:

Switch off ignition.  
Disconnect ground (earth) lead from battery.  
Insulate ground (earth) lead.

- Remove side sections of fairing.
- Remove top mudguard.
- Remove windshield.
- Remove headlight insert.

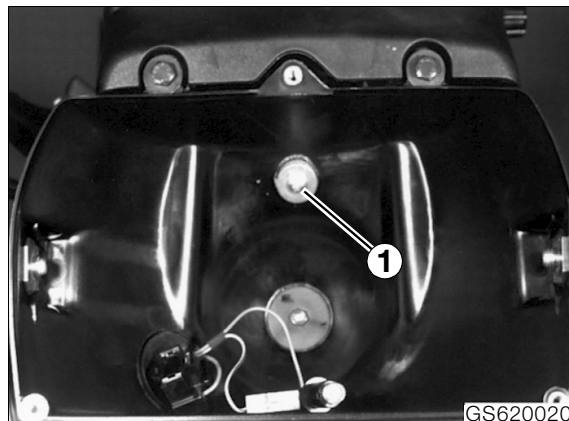

- Detach instrument cluster.



### Note:

Center retaining screw (1) is inside headlight housing.

- Remove headlight holder.
- Remove indicator glasses, pull off cable connector and draw cable through indicator holder.
- Remove indicators.
- Pull front trim section/top cover upwards to remove.
- Install in the reverse order of work.

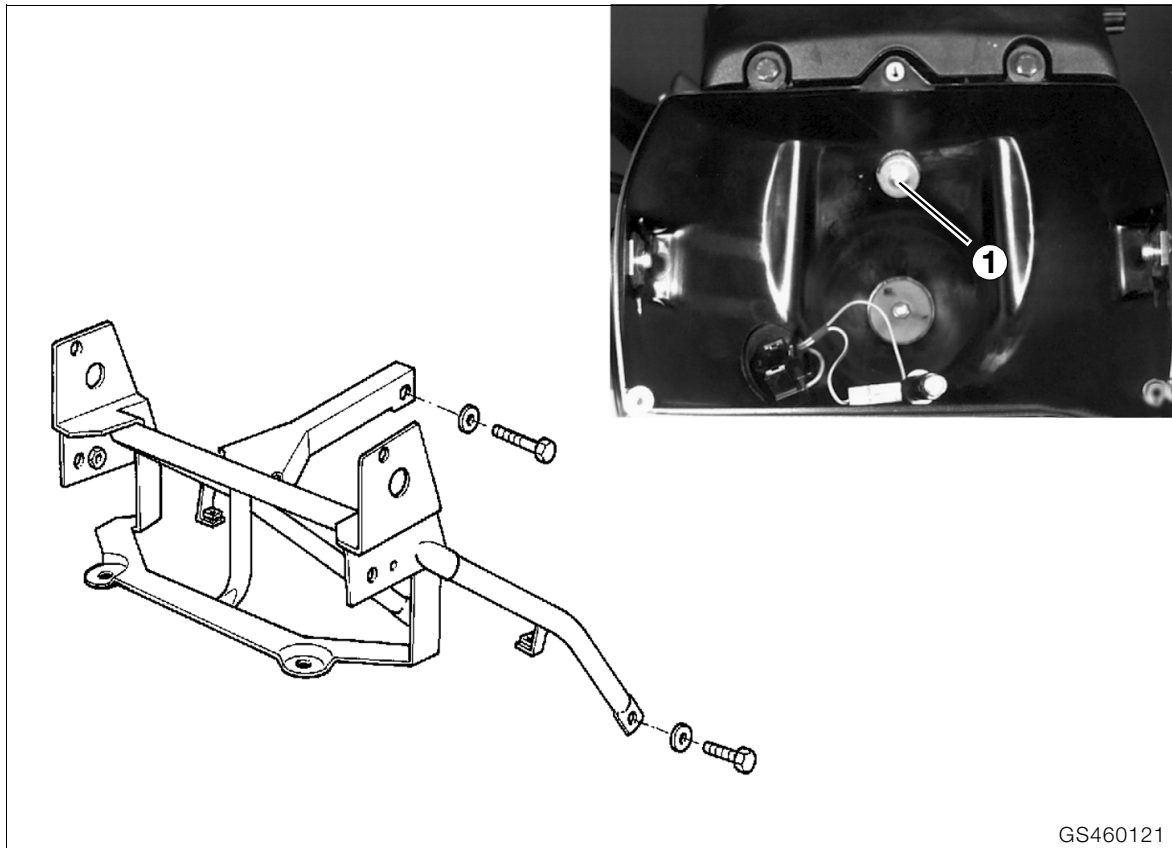

GS460121

## [GS] Removing and installing fairing holder



### Caution:

Switch off ignition.  
Disconnect ground (earth) lead from battery.  
Insulate ground (earth) lead.

- Remove side sections of fairing.
- Remove top mudguard.
- Remove windshield.
- Remove headlight insert.
- Detach instrument cluster.



### Note:

Center retaining screw (1) is inside headlight housing.

- Remove headlight holder.
- Remove indicator glasses, pull off cable connector and draw cable through indicator holder.
- Remove indicators.
- Pull front section of fairing/top cover upwards to remove.
- Detach wiring harness from trim holder.
- Detach oil cooler mount.
- Remove trim support bracket.
- Install in the reverse order of work.



### Tightening torque:

Fairing holder to frame ..... 20 Nm



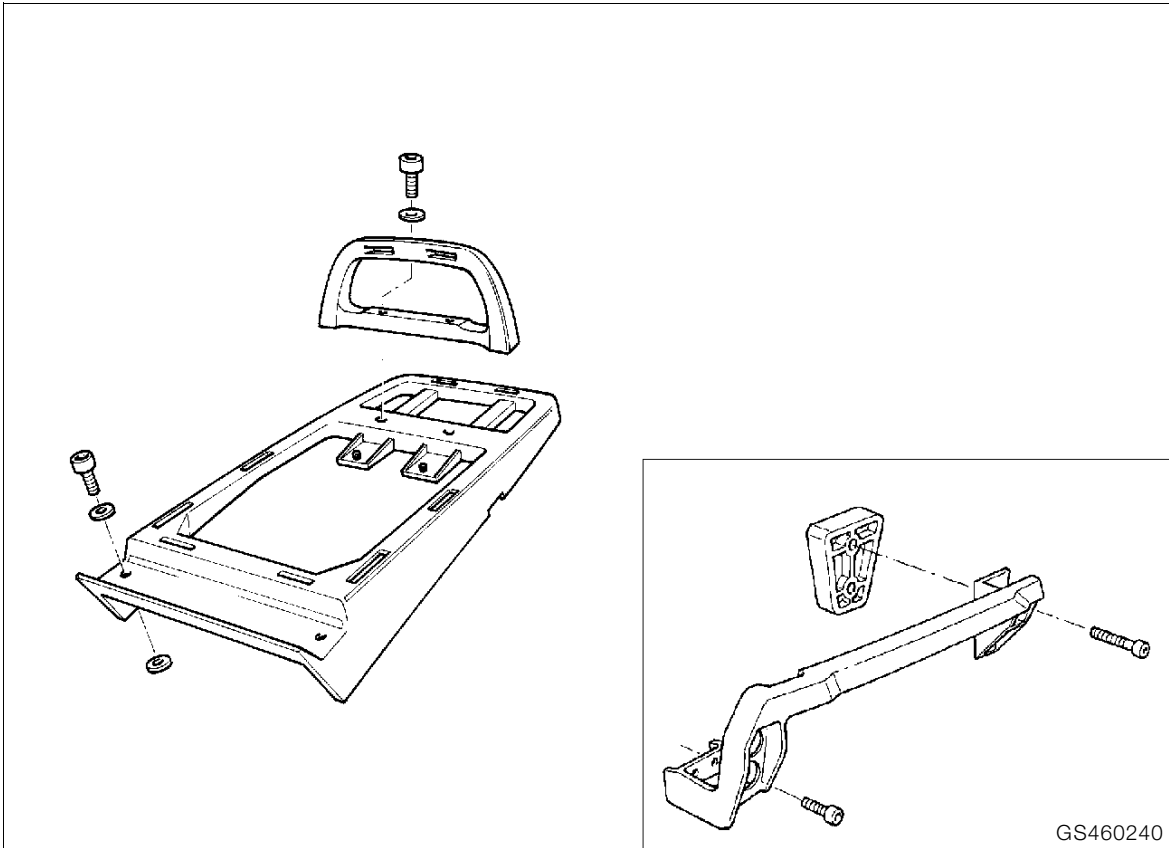

**[GS] Removing and installing luggage rack**

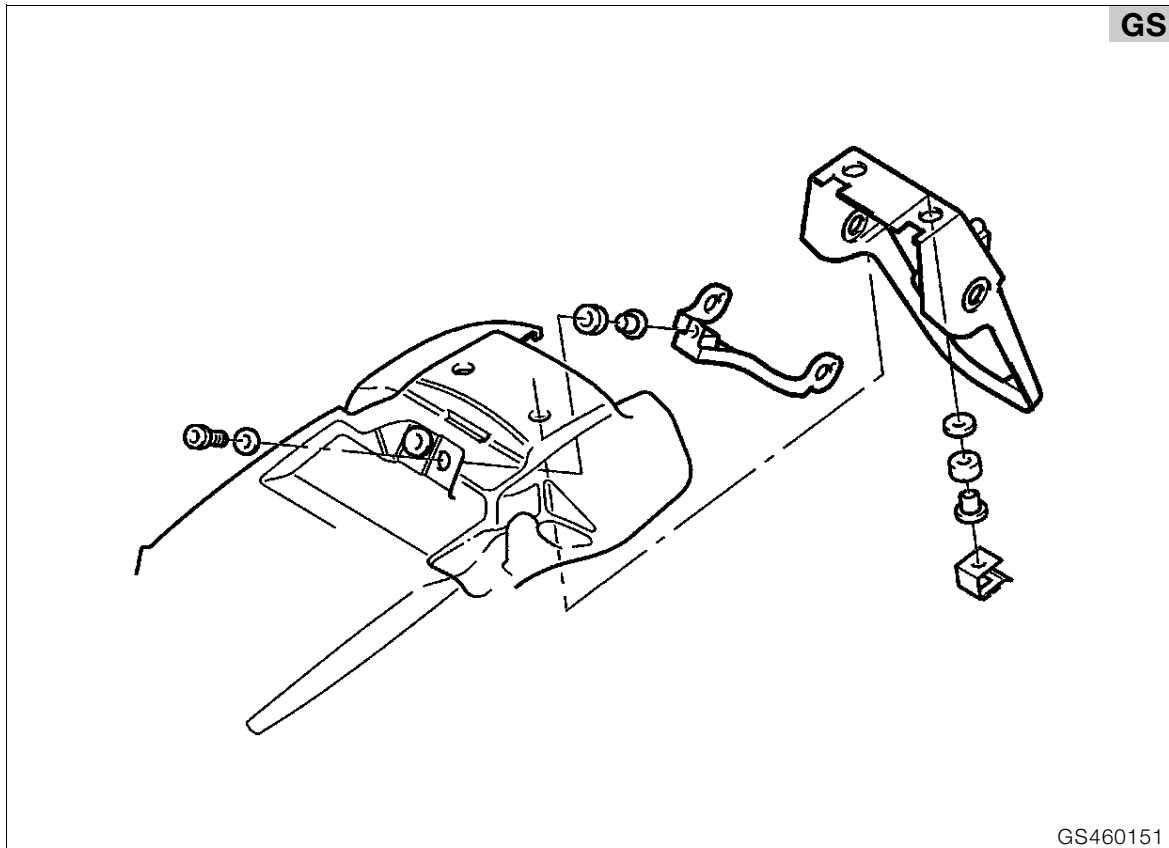

GS460151

### [GS/R] Removing and installing number plate bracket

- Take off rear section of dual seat.
- **[GS]** Remove tool box.
- **[GS]** Remove rear light.
- Remove turn indicators.
- Remove number plate bracket.
- Install in the reverse order of work.

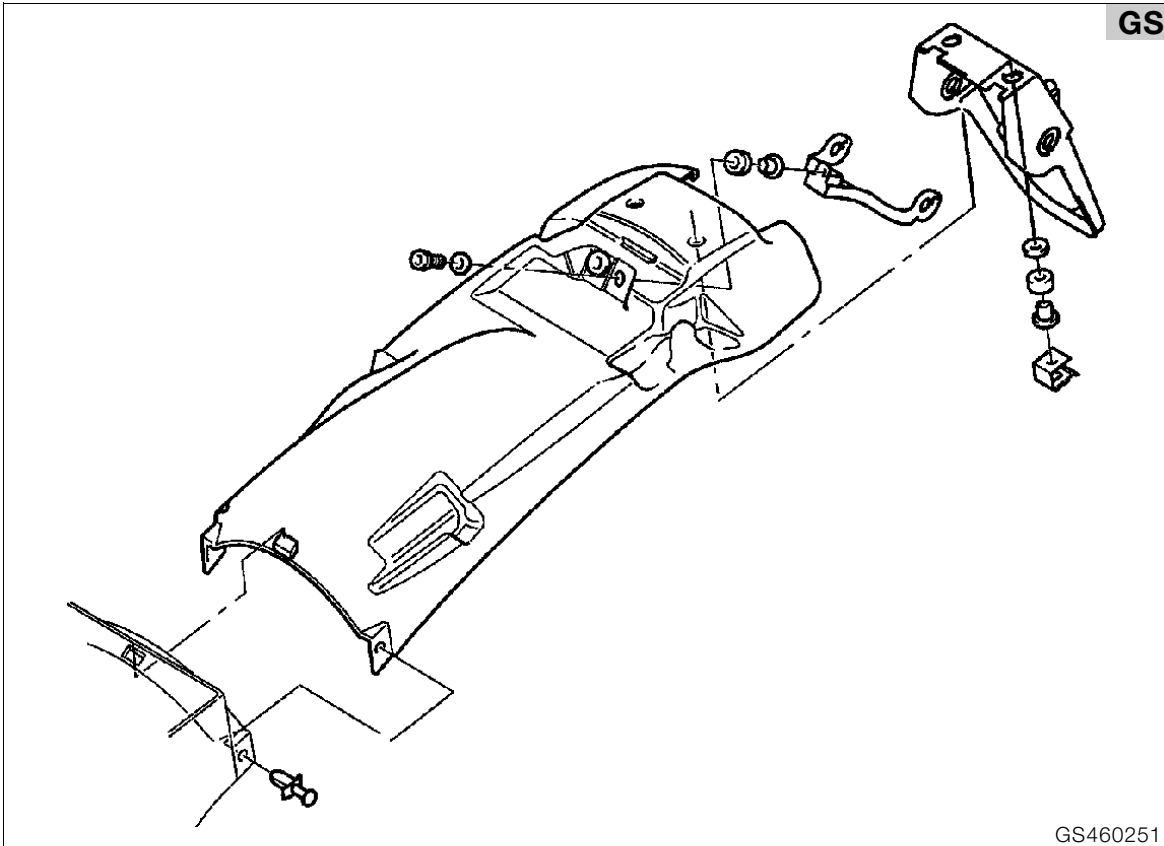

GS460251

## [GS/R] Removing and installing rear mudguard



### Caution:

Switch off ignition.  
 Disconnect ground (earth) lead from battery.  
 Insulate ground (earth) lead.

- Remove dualseat.
- **[GS]** Remove tool box.
- **[R]** Remove rear fairing.
- Disconnect plugs and leads from rear light and indicators.
- Remove number plate bracket.
- Detach mudguard.
- Remove wiring harness from rear section.
- Install in the reverse order of work.

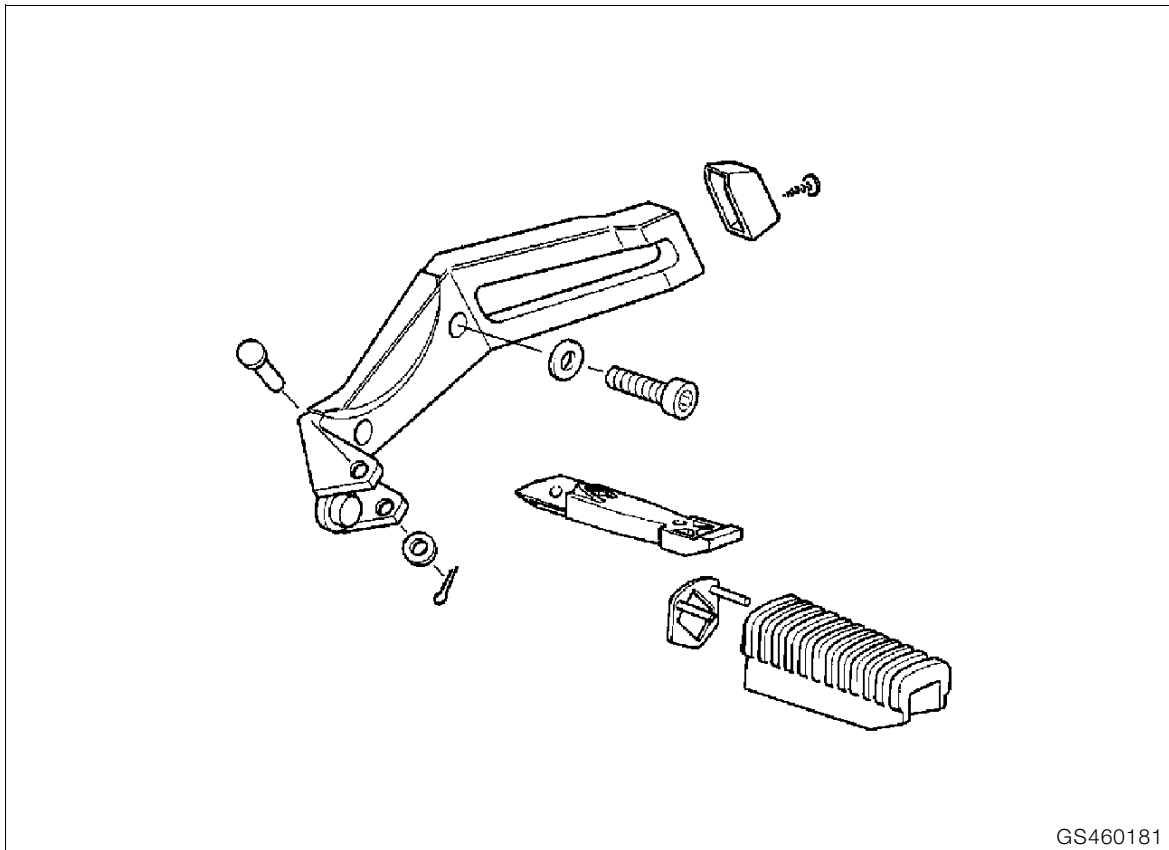

### [GS/R] Removing and installing rear footrest plate

 **Tightening torque:**  
Footrest plate to rear frame ..... 21 Nm



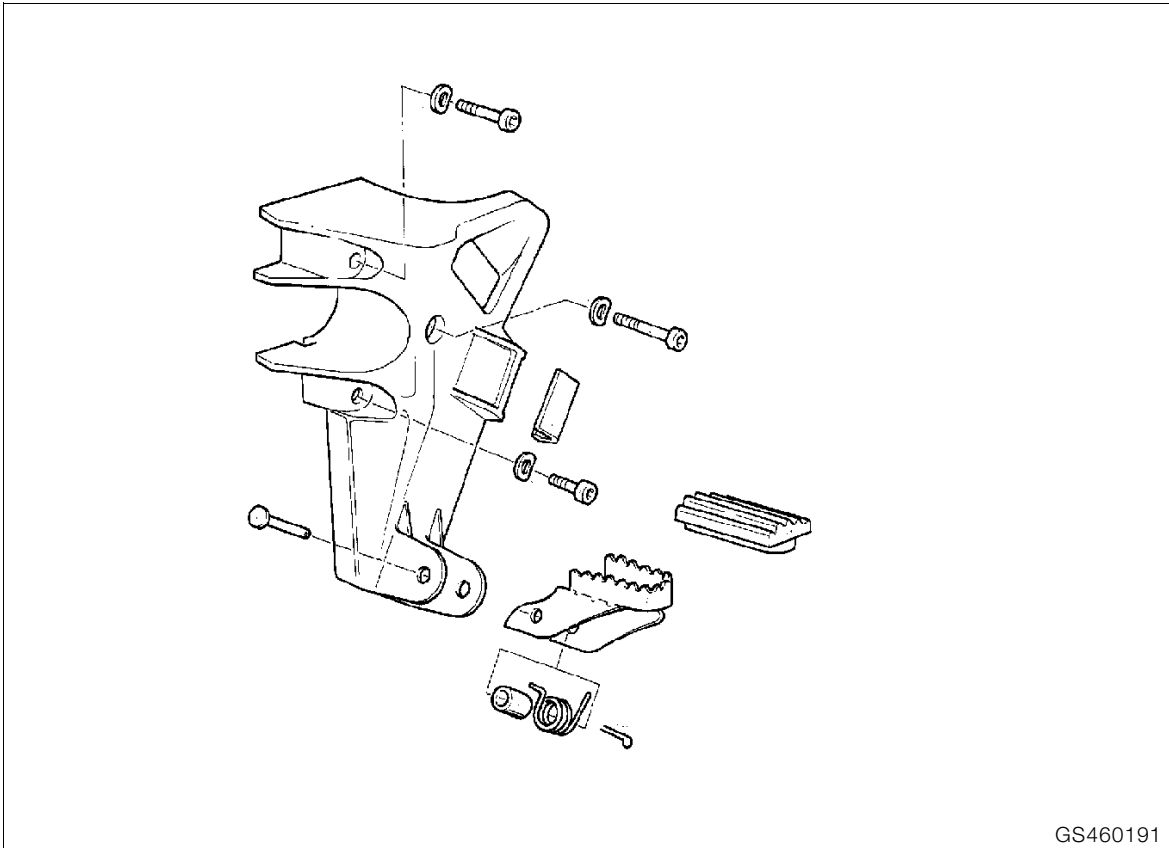

GS460191

### [GS] Removing and installing front footrest plate

-  **Tightening torque:**  
 Hydraulic spring adjuster  
 to footrest plate..... 22 Nm

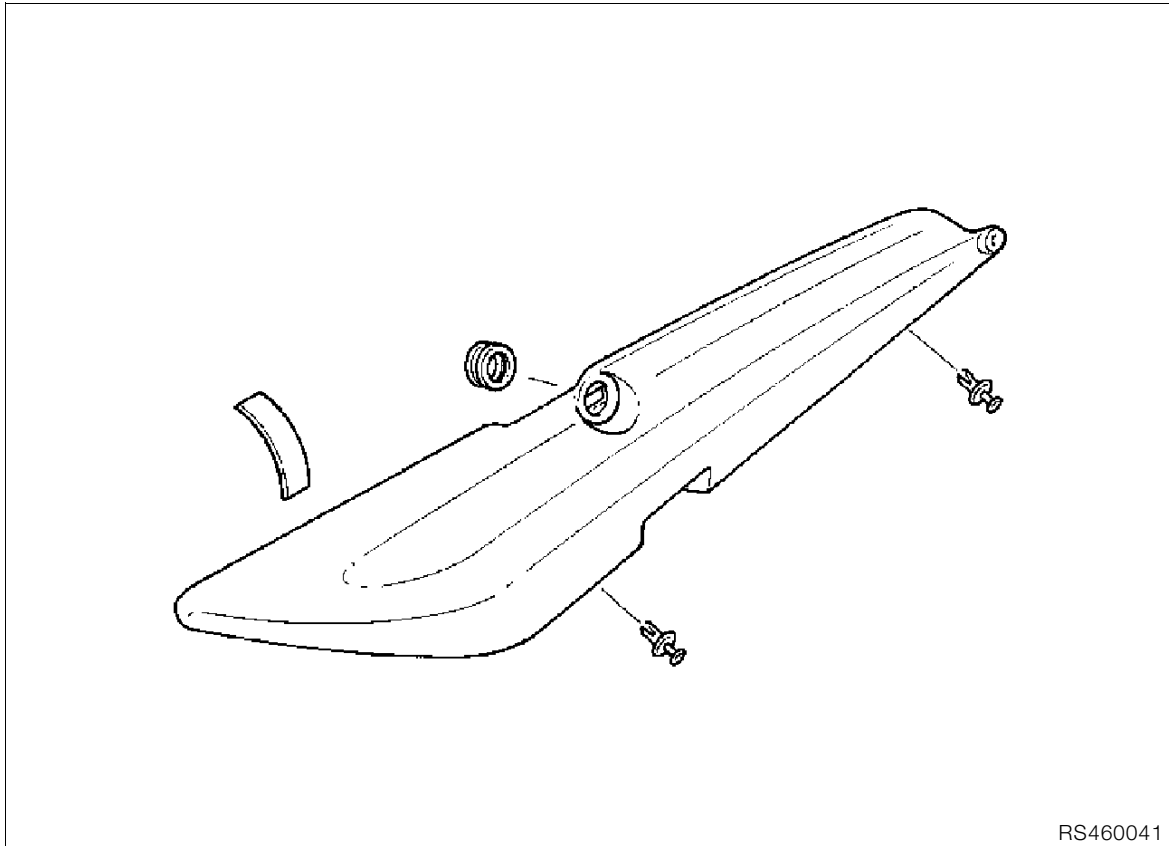

RS460041

**[R] Removing and installing rear  
fairing**

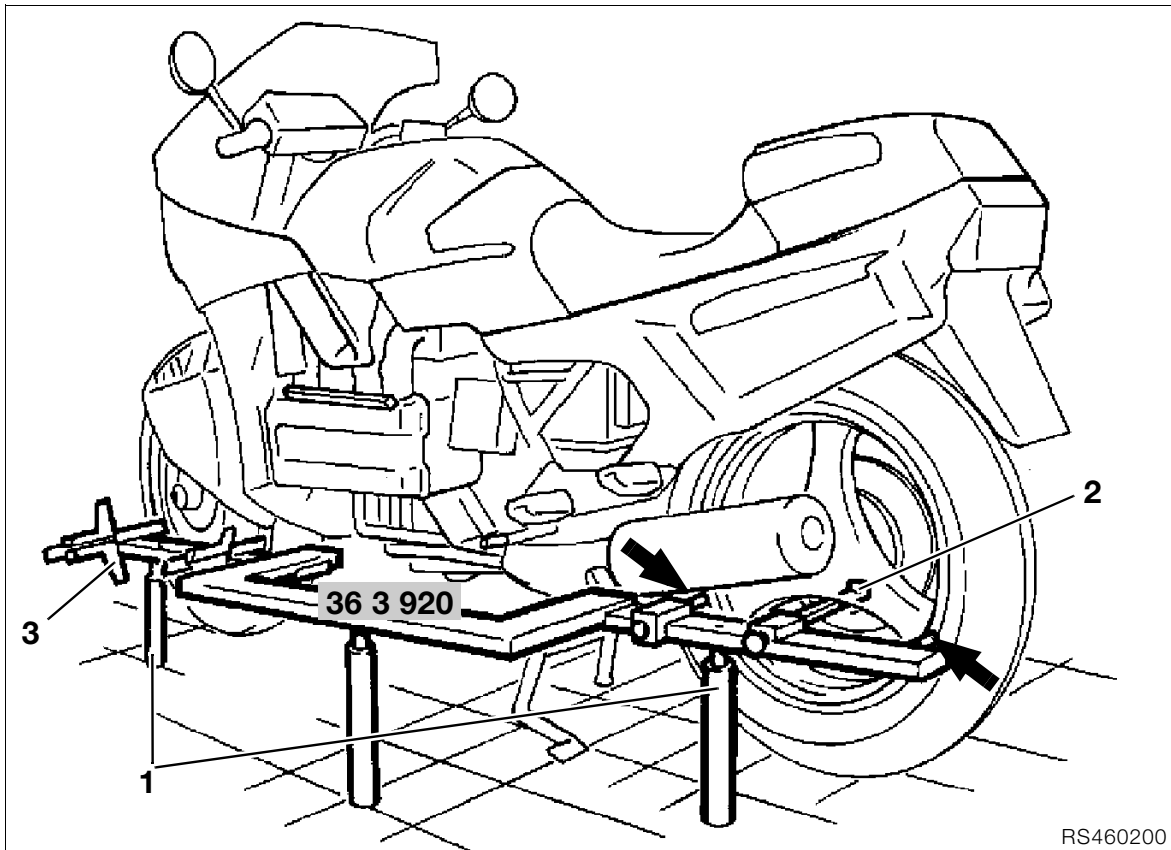

## Checking running gear

### Measuring wheel track offset

- Place vehicle on level ground on center stand.
- Place track alignment gauge, **BMW No. 36 3 920**, against left or right side of motorcycle.



#### Note:

In order to use the track alignment gauge on either the left or right side, simply screw the supports in on the other side.

- Adjust support (1) so that the measuring plane is as close as possible to the wheel centerline. The gauge must slide freely up to the motorcycle.
- Adjust measuring stops (arrows) until they contact the wheel rim - not the tyre.
- Attach hook (2) to wheel spoke to secure the gauge firmly to the wheel.
- Align front wheel parallel with the gauge.
- Measure distance between outer edge of gauge and wheel rim, using depth gauge (3) or ruler, and make a note of the dimension.

- Calculate wheel track offset S:
- Wheel track offset S is the distance to left or right between the longitudinal axes of the front and rear wheels.

Permissible track offset (S): ..... 9 mm (0.354 in)



**Note:**

**Explanation of measurement:**

Minus sign = track offset to left

Plus sign = track offset to right

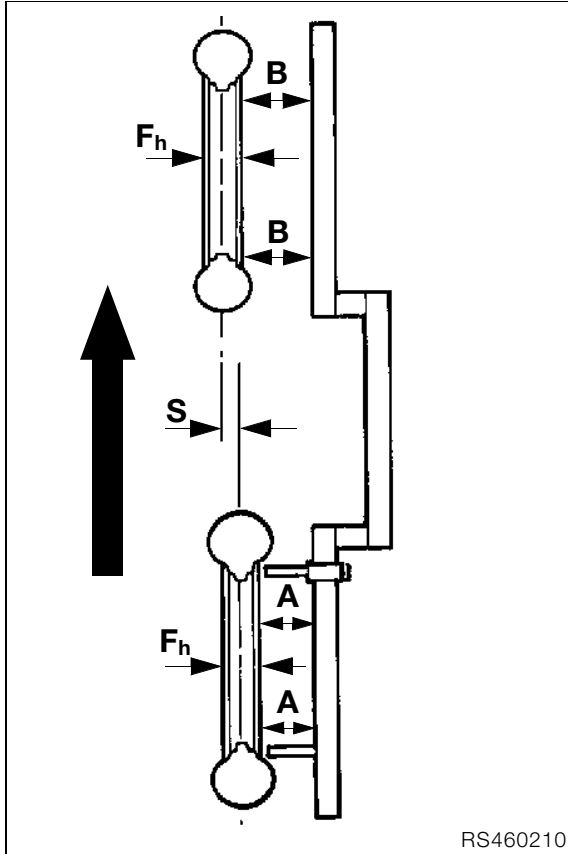

**EXAMPLE:**

Formula		$A + \frac{F_h}{2} - \left( B + \frac{F_v}{2} \right) = S$
Fixed value (A)		+half rim width
A	=	50,0 mm (1.9685 in)
$\frac{F_h}{2}$	=	44,5 mm (1.752 in)
$A + \frac{F_h}{2}$	=	94,5 mm (3.72 in)
Measured value (B)		+half rim width
B	=	52,0 mm (2.047in)
$\frac{F_v}{2}$	=	41,0 mm (1.614 in)
$B + \frac{F_v}{2}$	=	93,0 mm (3.66 in)
Fixed value (A)		-measured value (B) = S
94,5 mm (3.72 in)		-93,0 (3.66 in) = S
Wheel track offset:		
S	=	1,5 mm (0 059 in)



# 51 Equipment

Contents	Page
<b>Removing and installing ignition switch/steering lock</b> .....	3
Removing and installing ignition/light switch .....	3
Removing and installing lock barrel .....	3
Drilling out lock barrel .....	3
<b>Removing and installing lock barrel for fuel tank filler cap</b> .....	4
Drilling out lock barrel .....	4
<b>[RS/RT] Removing and installing dualseat lock</b> .....	5
Removing and installing lock barrel .....	5
<b>[GS] Removing and installing dualseat lock</b> .....	5
Removing and installing lock barrel .....	5
<b>[R] Removing and installing dualseat lock</b> .....	6
Removing and installing lock barrel .....	6
<b>[GS] Removing and installing helmet lock</b> .....	6
<b>[RT] Removing and installing storage compartment lock</b> .....	6





## Removing and installing ignition switch/steering lock

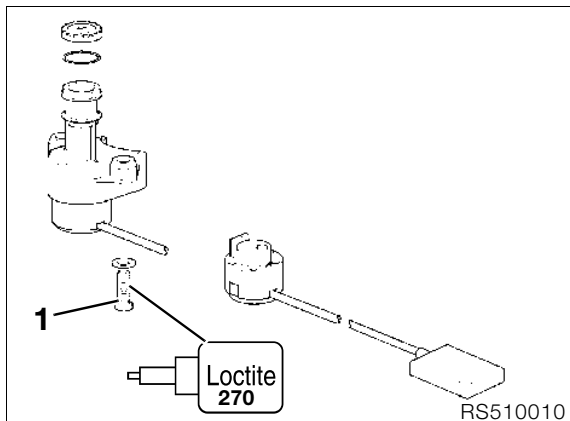

- Remove fork bridge.
- With a 4 mm (0.157 in) dia. drill bit, drill about 5 mm (0.1969 in) deep into serrated screw (1).
- Use an 8 mm (0.3149 in) dia. drill bit to drill away the screw head.
- Pull out the ignition switch/steering lock.
- Unscrew and remove stud bolt with stud bolt extractor.
- Install steering lock with serrated-screw socket wrench insert, **BMW No. 51 0 510**.



### ! Tightening torque:

Serrated screws  
(thread cleaned + Loctite 270)..... 15 Nm

## Removing and installing ignition/light switch

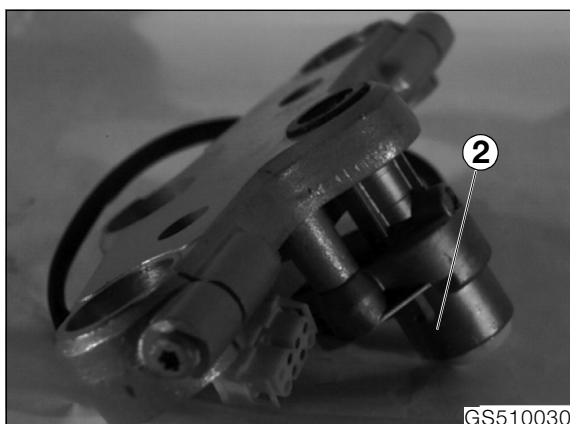

- Remove socket head cap screw (2).

## Removing and installing lock barrel

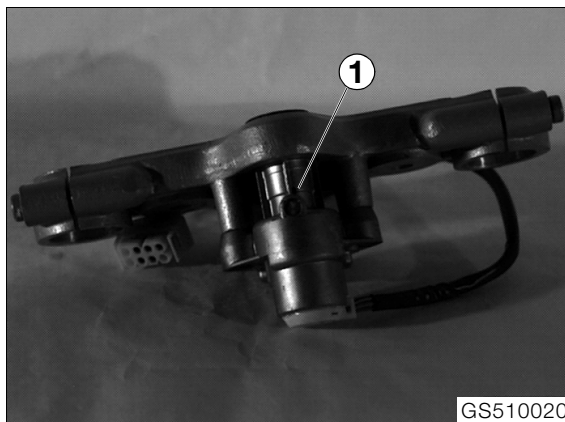

- Key in ON position/press in keeper (1) with a stiff wire or similar.
- Pull out lock barrel with key.
- Lubricate the new lock barrel with **Shell Retinax A**.
- Insert the lock barrel with the key in the ON position.
- Press lock barrel down until keeper engages.



### Drilling out lock barrel

- Use a 4-5 mm (0.157 - 0.1969 in) dia. drill bit to drill the full length of the lock barrel.
- Repeat with a drill bit of larger diameter until the lock barrel can be removed.

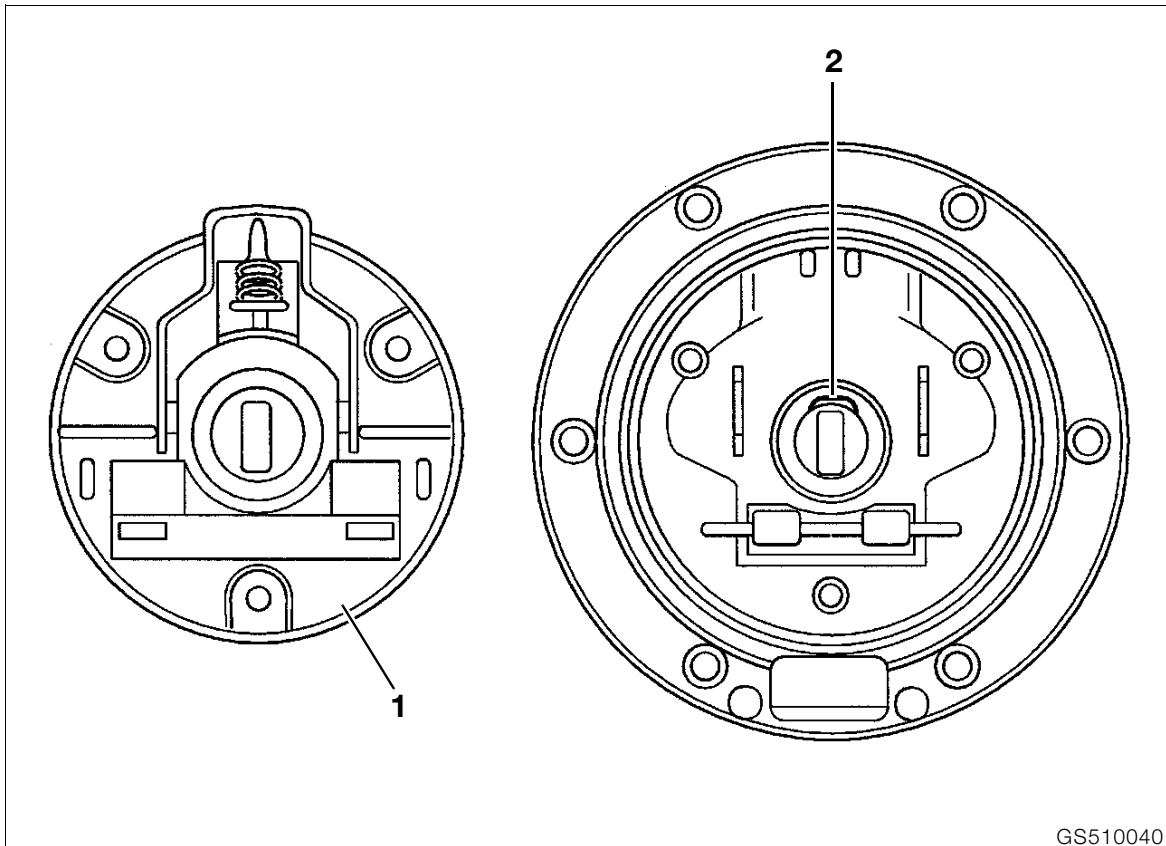

GS510040

## Removing and installing lock barrel for fuel tank filler cap



### Caution:

Prevent screws from falling into fuel tank:  
cover fuel tank filler neck with cloth.

- Open cap/remove lower part of cap (1).
- Insert key in lock barrel and press down on re-tainer (2).
- Pull out lock barrel with key.
- Grease new lock barrel with **Shell Retinax A**.
- Install lock barrel with key (at a right angle to direction of travel).
- Install in the reverse order of work.

### Drilling out lock barrel

- Drill out entire length of lock barrel with a 4-5 mm ( 0.157 - 0.1969 in) dia. twist drill bit.
- Repeat with a larger diameter drill bit until the lock barrel can be removed.



## [RS/RT] Removing and installing dualseat lock

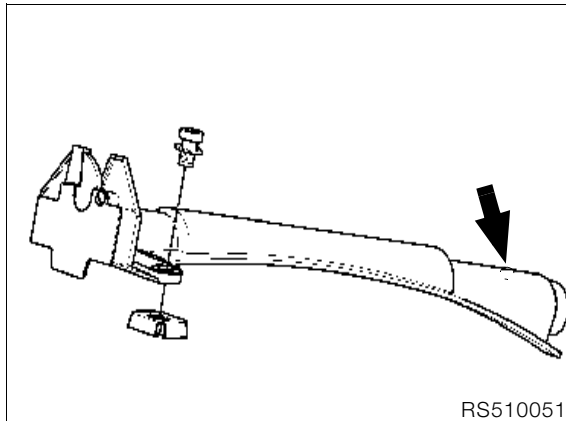

## [GS] Removing and installing dualseat lock

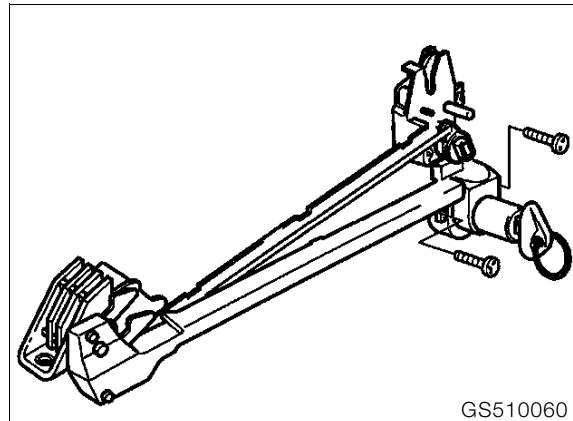

### Removing and installing lock barrel

- Press down retainer (arrow) with a piece of wire or similar.
- Pull out lock barrel with key.
- Lubricate the new lock barrel with **Shell Retinax A**.
- Insert lock barrel until retainer engages.

### Removing and installing lock barrel

- Remove luggage rack.
- Remove dualseat lock.
- Dismantle key side of dualseat lock (2 screws) and open up carefully.

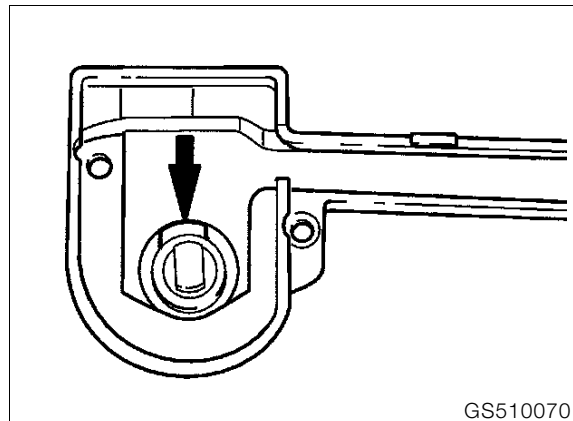

- Press the locating tongue (arrow) of the lock barrel in the housing and pull the lock barrel out with the key.
- Lubricate the new lock barrel with **Shell Retinax A**.
- Insert lock barrel until retainer engages.
- Install in the reverse order of work.

## [R] Removing and installing dualseat lock

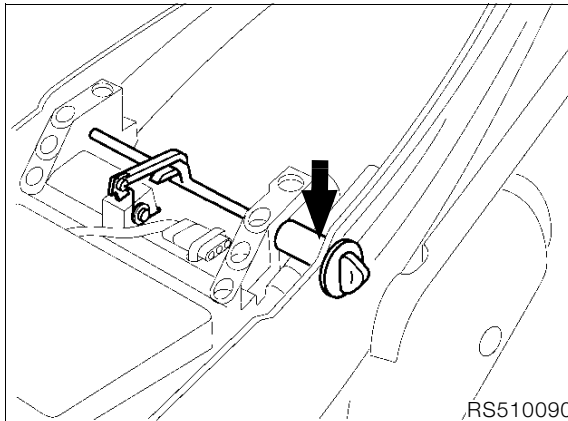

## [RT] Removing and installing storage compartment lock



### Removing and installing lock barrel

- Press down retainer (arrow) with a piece of wire or similar.
- Pull out lock barrel with key.
- Lubricate the new lock barrel with **Shell Retinax A**.
- Insert lock barrel until retainer engages.

## [GS] Removing and installing helmet lock

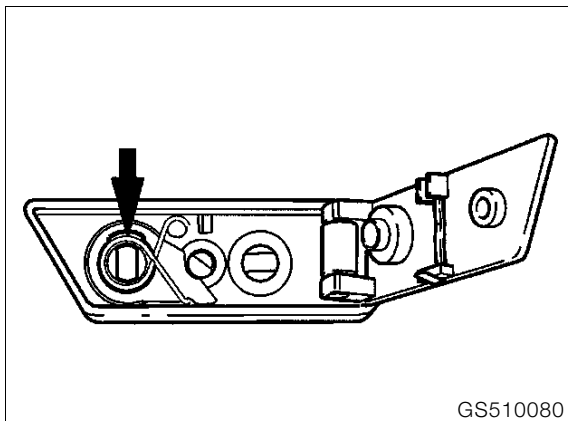

- Open retaining bracket.
- Remove helmet lock.
- Use screwdriver to lever out inside cover.
- Remove spring and retaining hook.
- Press retaining lug on lock barrel down into housing and remove lock barrel with key.
- Lubricate the new lock barrel with **Shell Retinax A**.
- Insert lock barrel until retainer engages.
- Install in the reverse order of work.

- Press in safety peg (arrow) with a piece of wire or similar.
- Take off the locking section (1).
- Pull out lock barrel with key.
- Lubricate the new lock barrel with **Shell Retinax A**.
- Press the retaining lug into the lock barrel and insert until the detent engages.
- Press the locking section back on and press in the safety peg.

# 52 Seat

## Contents

Page

<b>[RT] Dismantling and assembling dualseat .....</b>	<b>3</b>
<b>[RS] Dismantling and assembling dualseat .....</b>	<b>4</b>
<b>[GS/R] Dismantling and assembling dualseat .....</b>	<b>5</b>





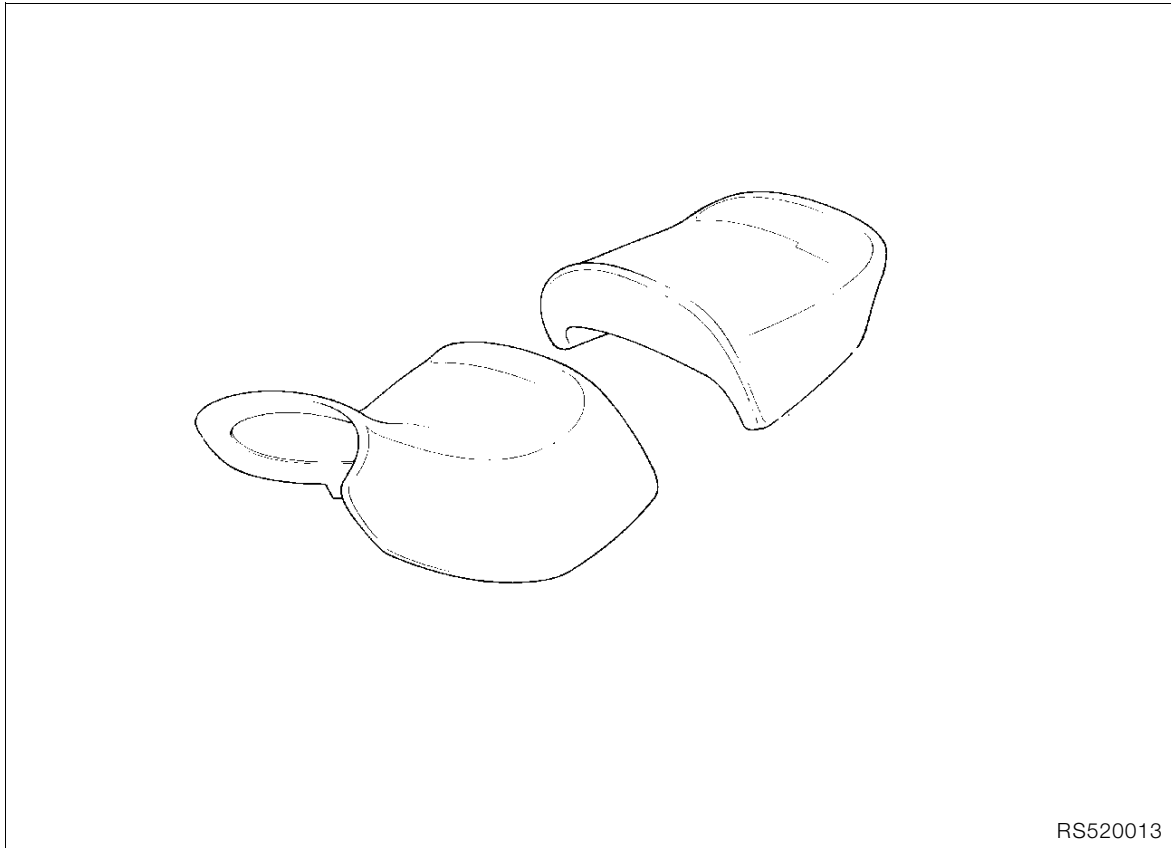

RS520013



**[RT] Dismantling and assembling  
dualseat**

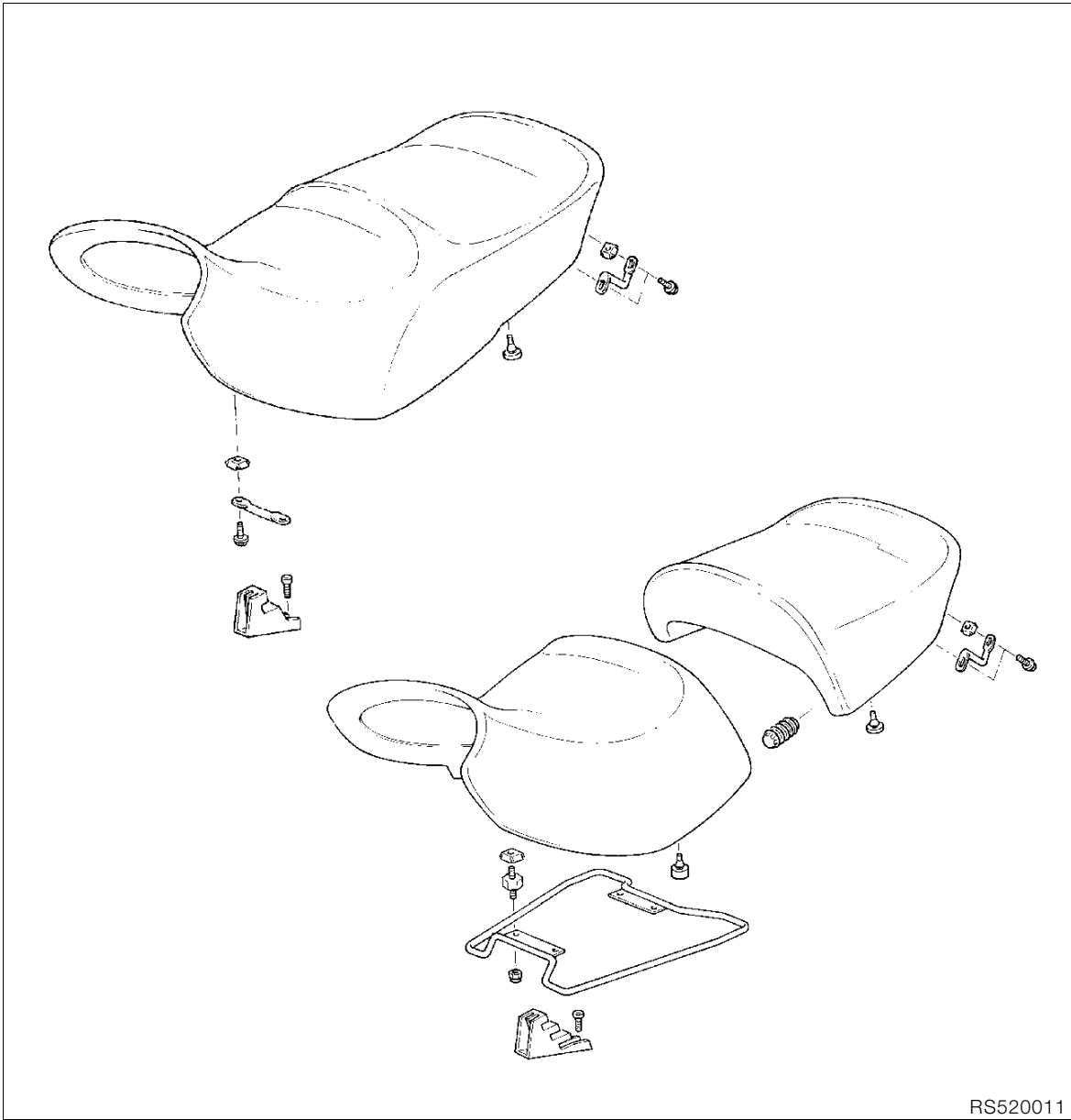

RS520011

**[RS] Dismantling and assembling  
dualseat**

GS

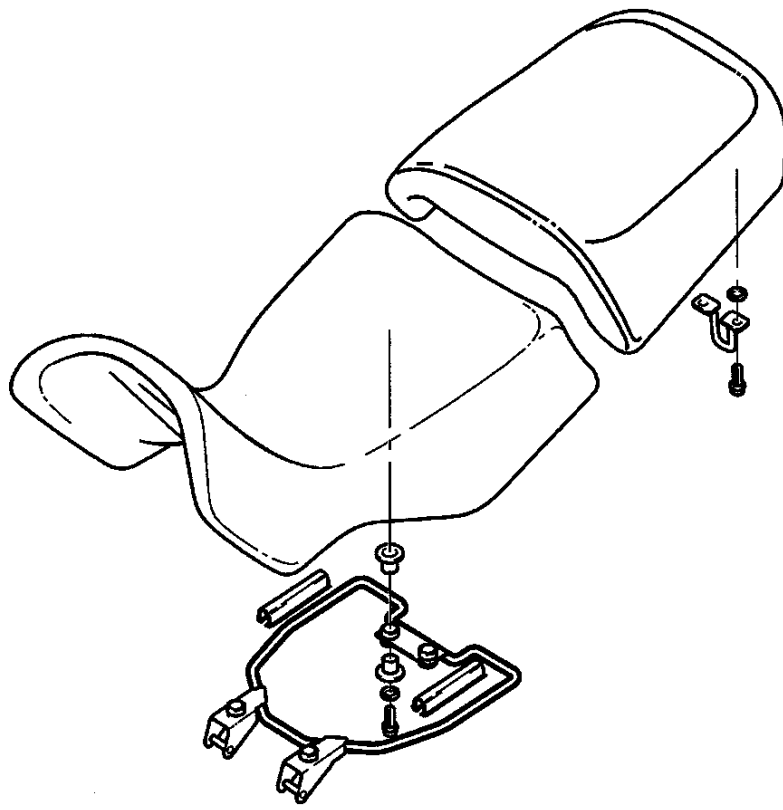

RS520020



R

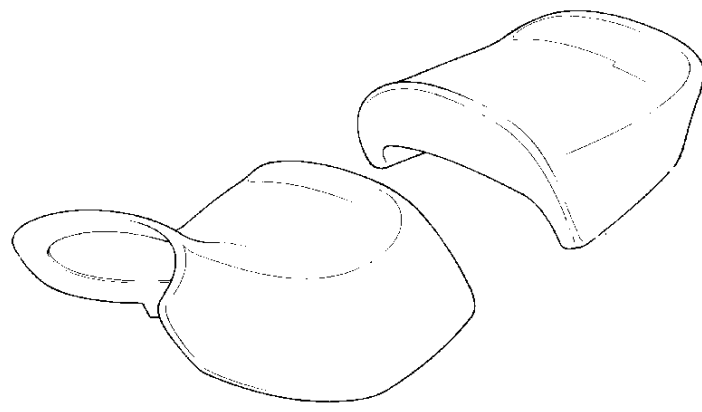

RS520013

**[GS/R] Dismantling and assembling  
dualseat**

# 61 General electrical equipment

<b>Contents</b>	Page
<b>Technical Data</b> .....	3
<b>Removing and installing central electrical equipment box</b> .....	7
<b>Dismantling/assembling central electrical equipment box</b> .....	7
<b>Relay positions (central electrical equipment box)</b> .....	8
Connections to fuses: [RS/GS/R] .....	8
Connections to fuses: [RT] .....	8
<b>Frame wiring harness [ABS]</b> .....	9
Installing wiring harness/connections in central electrical equipment box .....	10
Installing wiring harness in central electrical equipment box/output .....	11
[RT] Wiring harness View from left .....	12
[RT] Wiring harness View from right .....	16
[RT] Wiring harness at fairing holder .....	19
[RT] Wiring harness at instrument cluster .....	20
[RS] Wiring harness View from left .....	21
[RS] Wiring harness View from right .....	25
[RS] Wiring harness at left switch unit .....	28
[RS] Wiring harness at right switch unit .....	29
[GS] Wiring harness View from left .....	30
[GS] Wiring harness View from right .....	34
<b>Removing and installing battery holder</b> .....	37







Technical Data		R 1100 RS
Battery	Ah	19

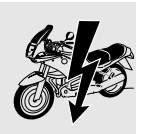

Technical Data		R 1100 RT
Battery	Ah	19



<b>Technical Data</b>		<b>R 850 GS</b>	<b>R 1100 GS</b>
Battery	Ah	19	19

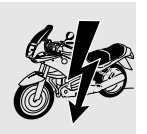

Technical Data	R 850 R	R 1100 R
Battery	Ah 19	19



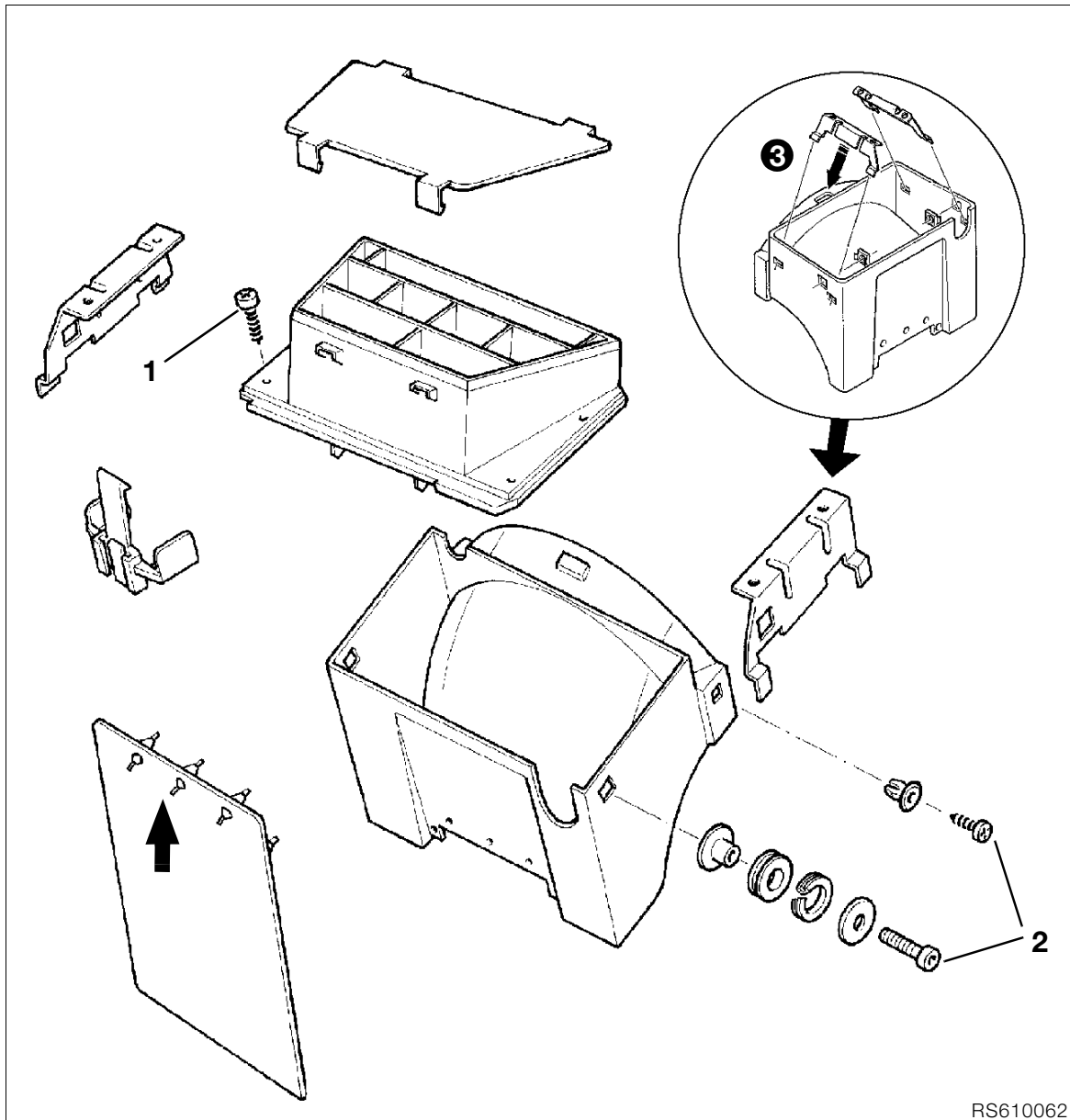

RS610062

## Removing and installing central electrical equipment box



### Caution:

Switch off ignition.  
Disconnect ground (earth) lead from battery.  
Insulate ground (earth) lead.

- Remove dualseat.
- **[RT]** Remove small side fairing sections at left and right.
- **[RT]** Remove luggage rack/case holder.
- **[RS/R/RT]** Take off rear fairing at left and right.
- **[RT]** Remove lower rear section.
- Take out retaining screws (1) for upper section of central electrical equipment box.

- Take out retaining screws (2) for lower section of central electrical equipment box.
- Remove cable tray.
- If necessary, detach complete wiring harness and remove it with the fuse box, or remove the relays and relay bases.
- Install in the reverse order of work.
- After assembly, shorten the rubber tag on the splash guard mount (arrow) to 10 mm (0.4 in).

## Dismantling/assembling central electrical equipment box

- See detail drawing (3).

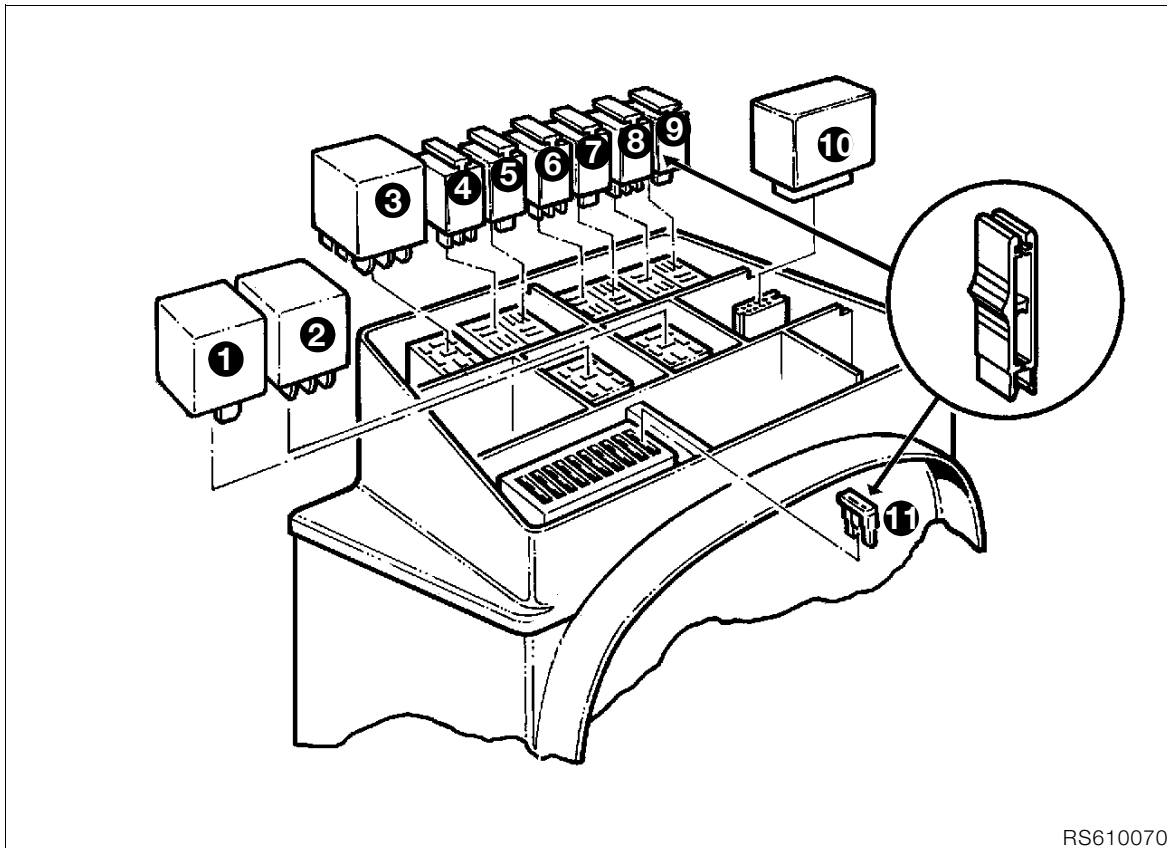

RS610070



### Relay positions (central electrical equipment box)

1. Encoding plug for Motronic and catalytic converter
2. Fuel gauge/display damping
3. Starter motor relay
4. Load-relief relay
5. Horn relay
6. Fuel pump relay
7. Motronic relay
8. ABS warning relay
9. Not in use
10. Flasher unit
11. Fuse

### Connections to fuses: [RT]

(No. 1 on left, looking forwards)

- |   |        |
|---|--------|
| 1. Instrument cluster,<br>brake and rear lights ..... | 15 Amp |
| 2. Parking light .....                                | 15 Amp |
| 3. Flashing turn indicators, clock.....               | 15 Amp |
| 4. Power socket .....                                 | 15 Amp |
| 5. Motronic.....                                      | 15 Amp |
| 6. Fuel pump .....                                    | 15 Amp |
| 7. Heated handlebar grips.....                        | 4 Amp  |
| 8. Radio .....  | 15 Amp |
| 9. Spare fuse.....                                    | 15 Amp |
| 10. Spare fuse.....                                   | 4 Amp  |

### Connections to fuses: [RS/GS/R]

(No. 1 on left, looking forwards)

- |   |        |
|---|--------|
| 1. Instrument cluster,<br>brake and rear lights ..... | 15 Amp |
| 2. Parking light .....                                | 15 Amp |
| 3. Flashing turn indicators, clock.....               | 15 Amp |
| 4. Power socket .....                                 | 15 Amp |
| 5. Motronic.....                                      | 15 Amp |
| 6. Fuel pump .....                                    | 15 Amp |
| 7. Heated handlebar grips .....                       | 4 Amp  |
| 8. Spare fuse.....                                    | 4 Amp  |
| 9. Spare fuse.....                                    | 15 Amp |
| 10. Spare fuse.....                                   | 15 Amp |

## Frame wiring harness [ABS]



### Caution:

Threaded earth (ground) connection at engine: use galvanized (yellow) screws. Screws with unsuitable corrosion proofing can cause the electrical resistance to rise as high as 80  $\Omega$ . Run wiring without kinking and avoid risk of abrasion.

Note the number and position of the cable straps.

- Apply a thin coating of contact grease, e.g. **CENTOPLEX 3 CU** to the central earth (ground) point, which must be cleaned to bright metal first.



### Note:

When removing the wiring harness, take out the central electrical equipment box at the same time. When installing, fit the central electrical equipment box first.



### Tightening torque:

Ground (earth) connection to engine ..... 10 Nm

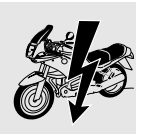



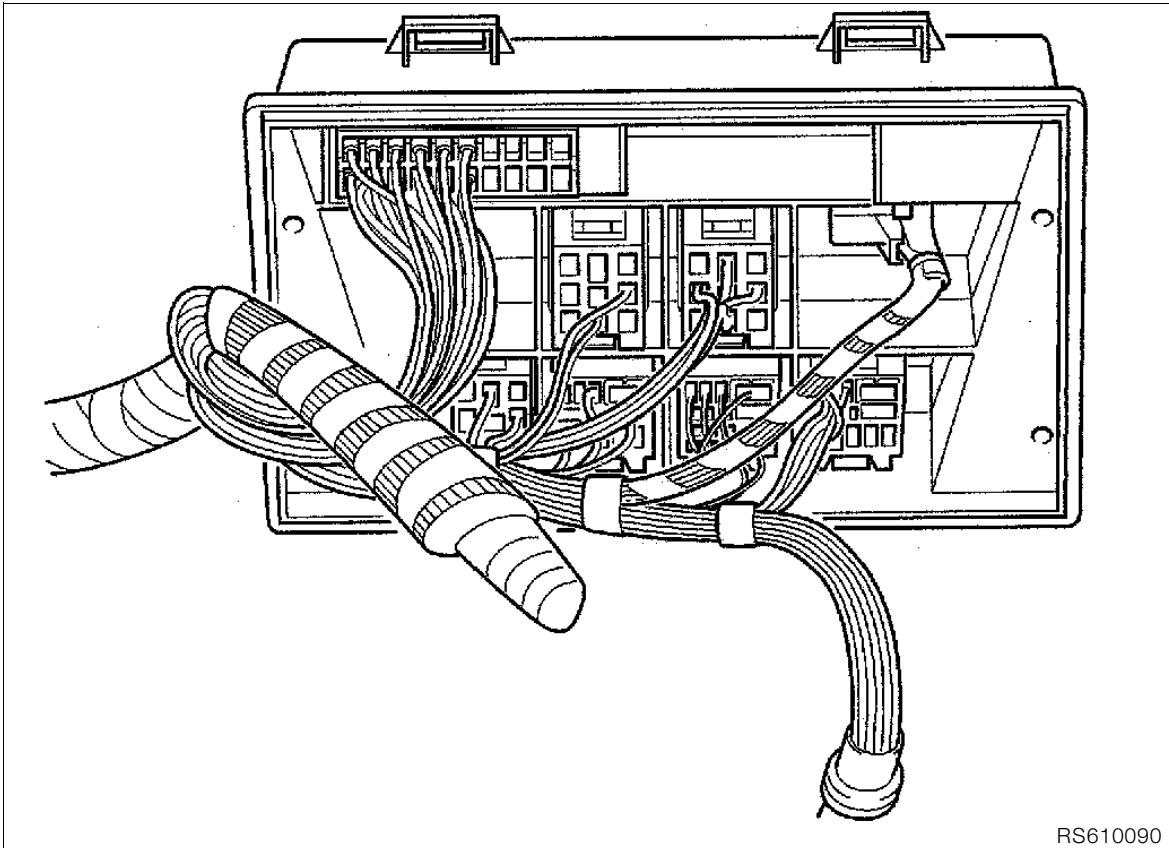

RS610090



Installing wiring harness/connections  
in central electrical equipment box

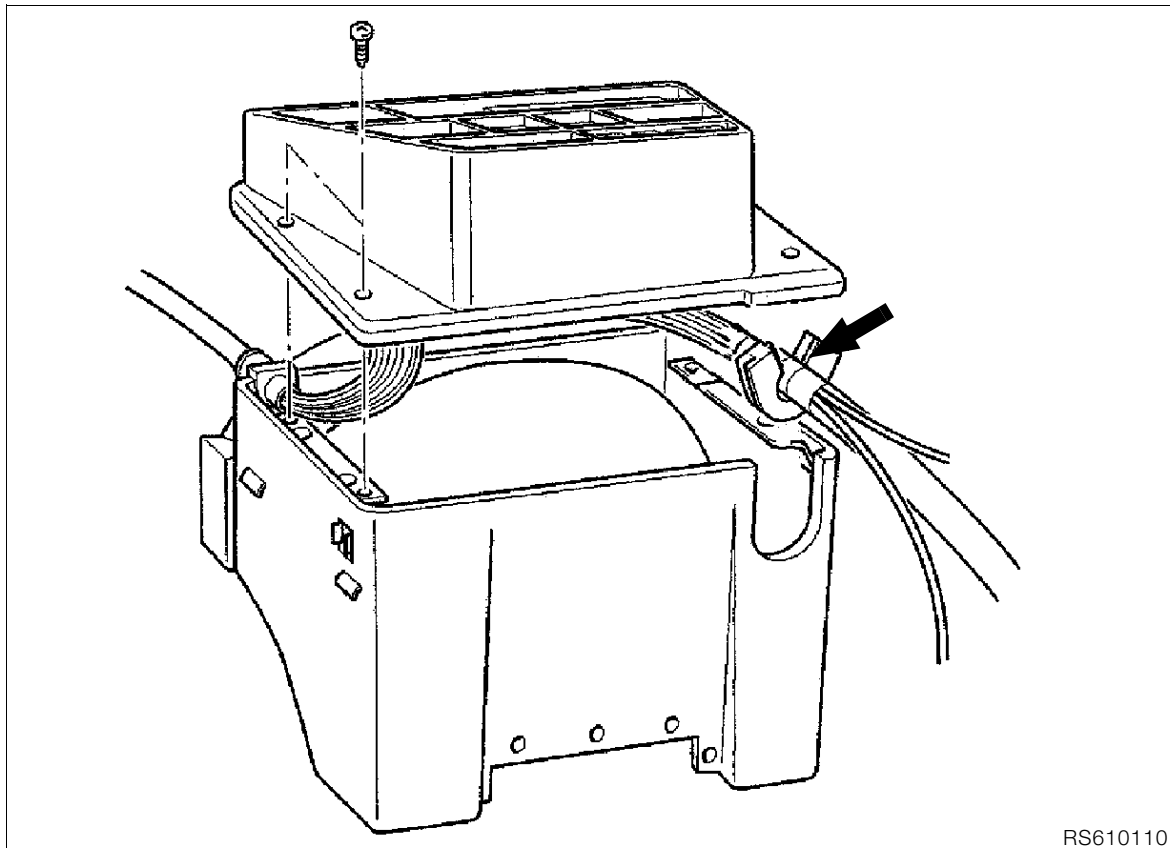

RS610110

### Installing wiring harness in central electrical equipment box/output



**Note:**

The white marker tape (arrow) must be covered by the cable entry grommet.

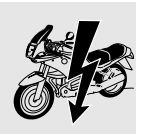

[RT] Wiring harness View from left

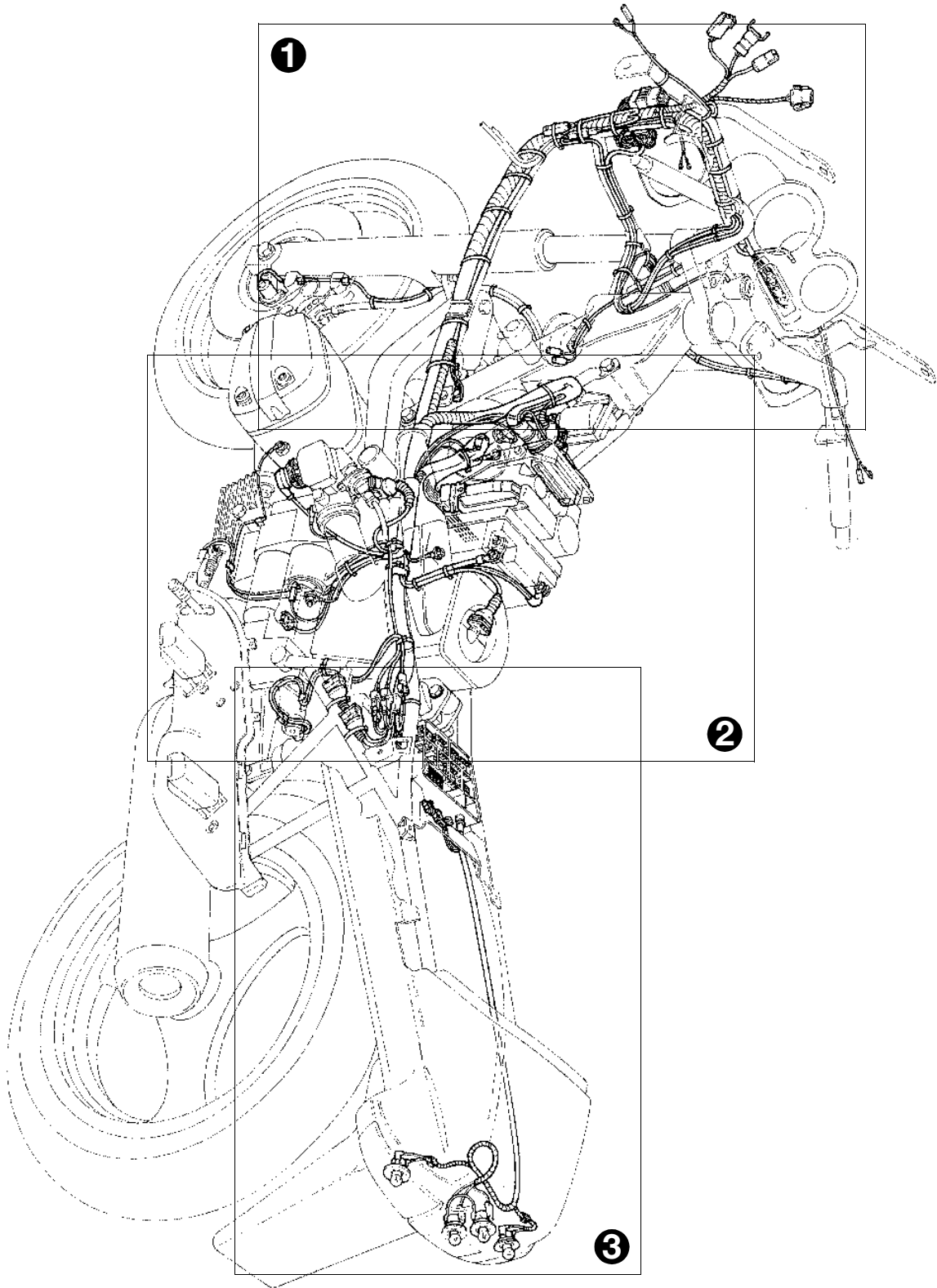

RT610160

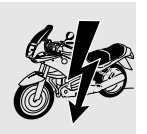
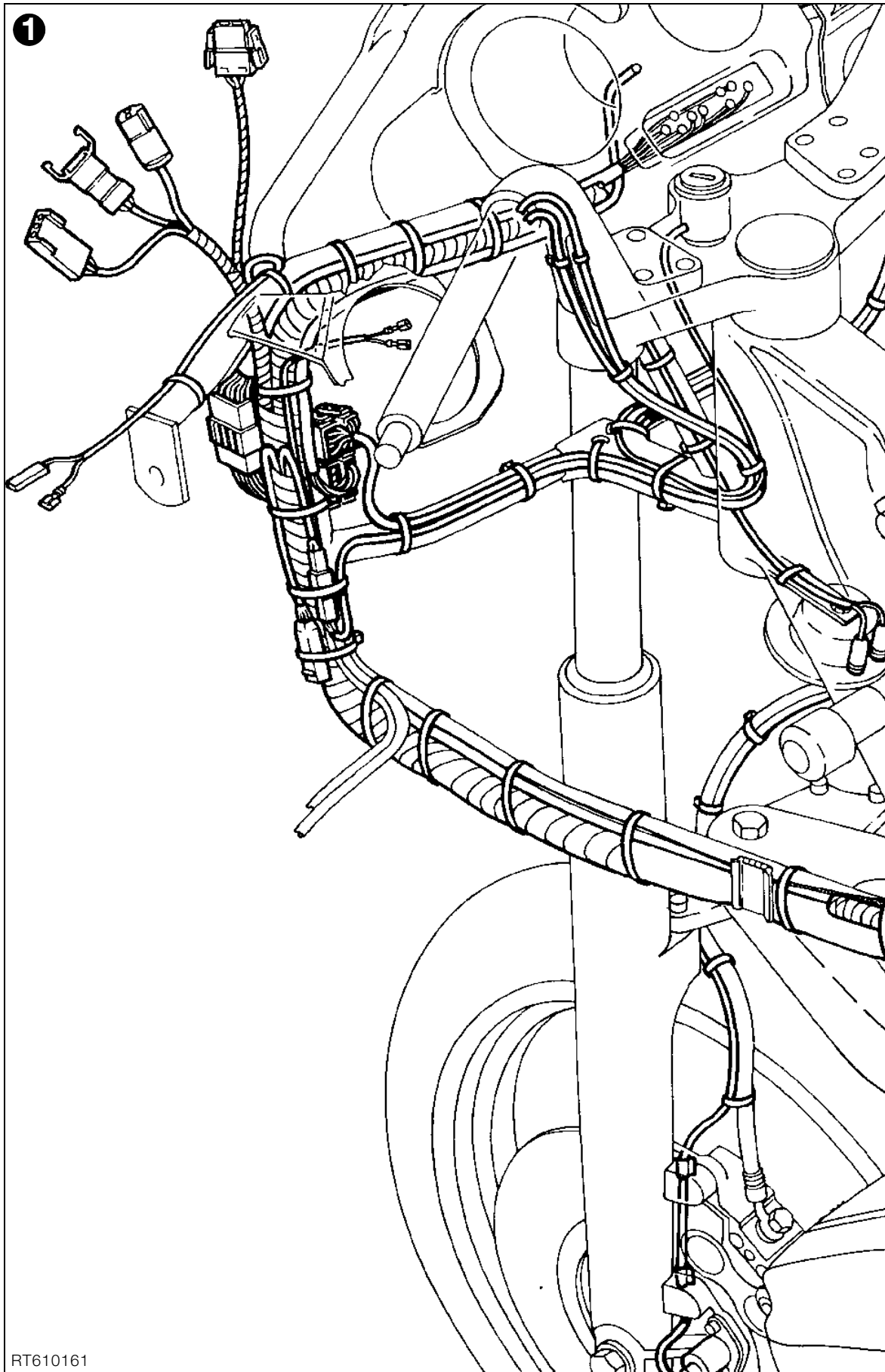

2

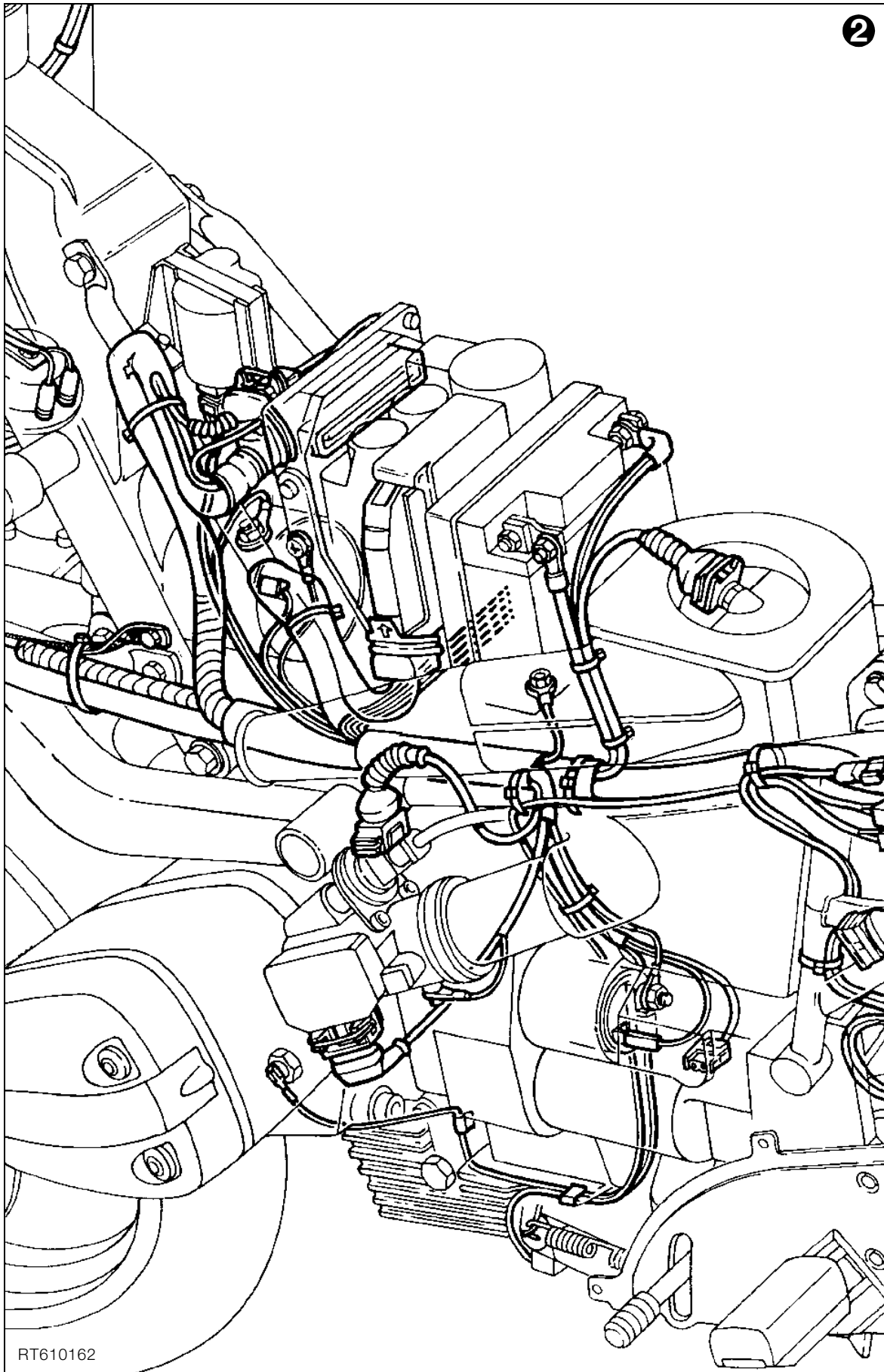

RT610162

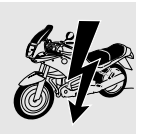
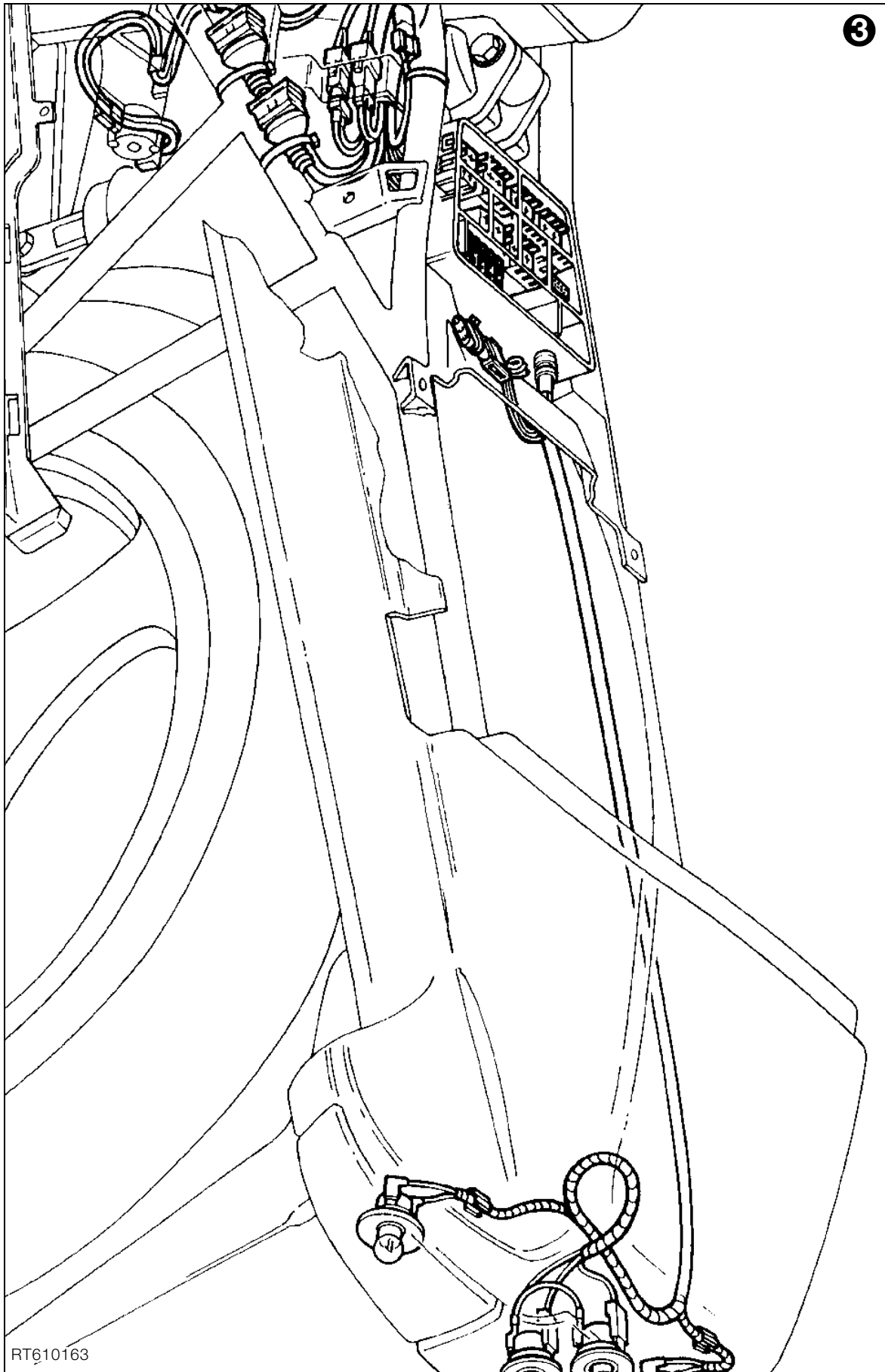

[RT] Wiring harness View from right

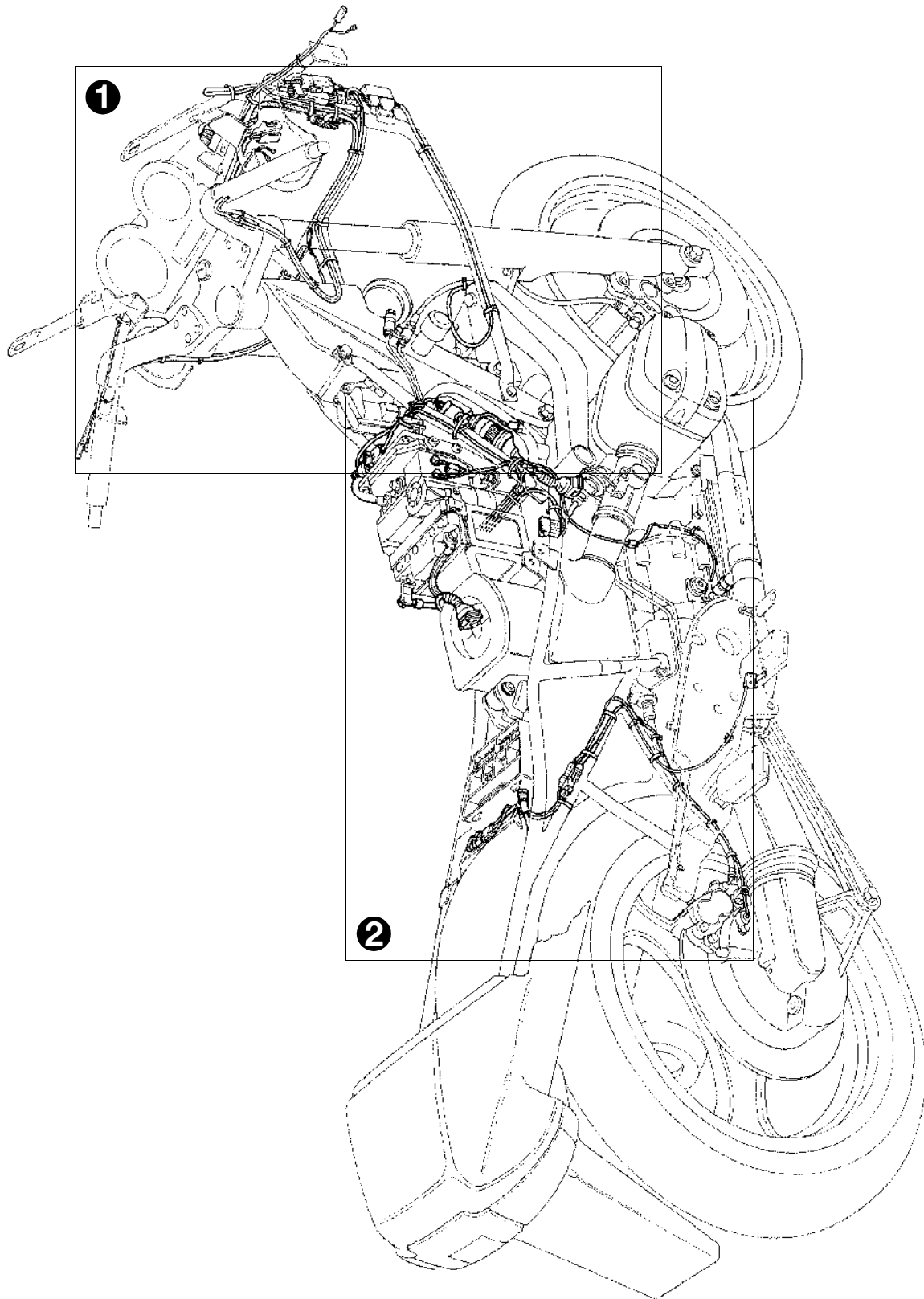

RS610170

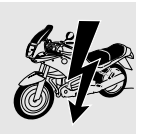
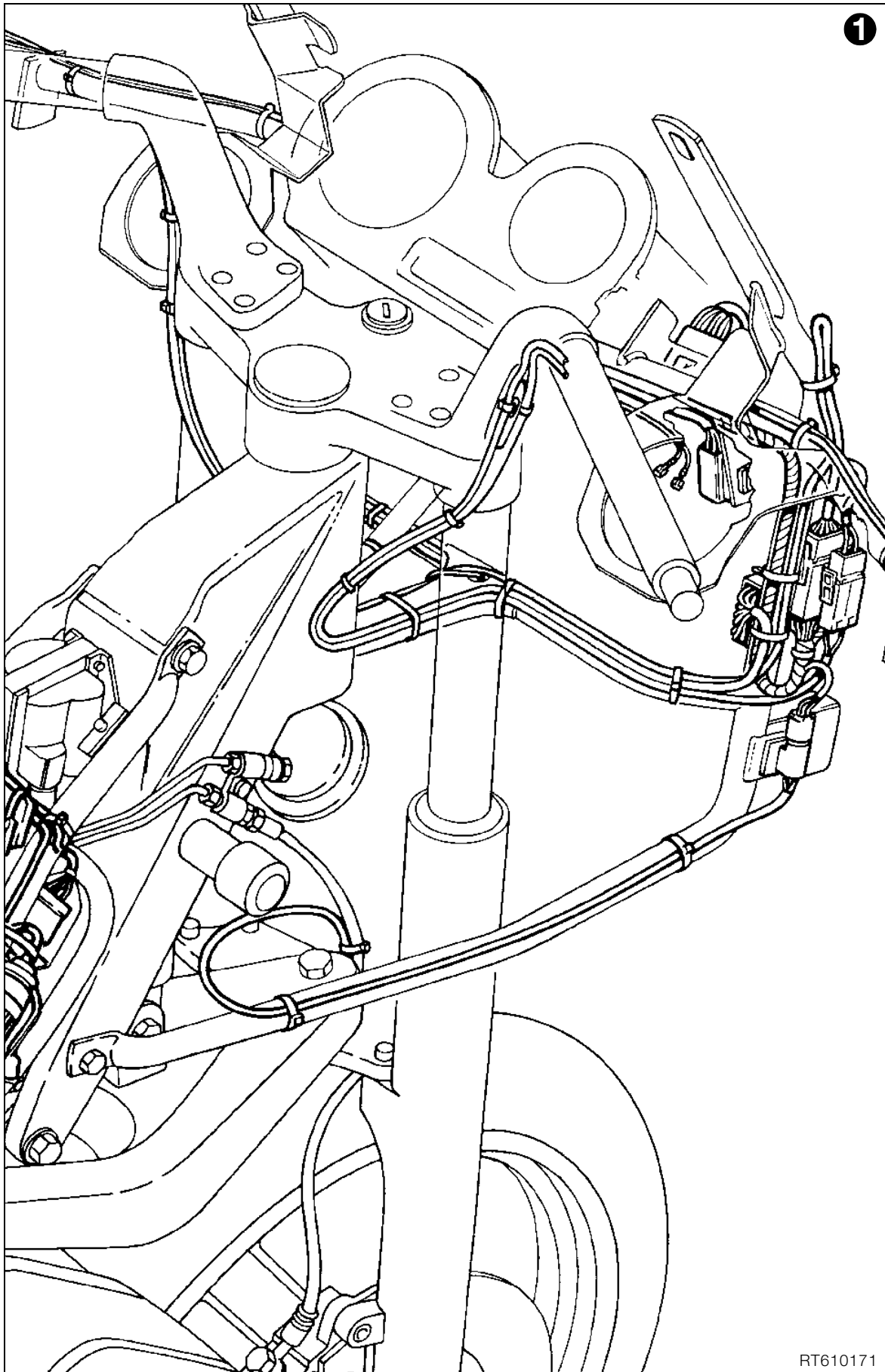

RT610171



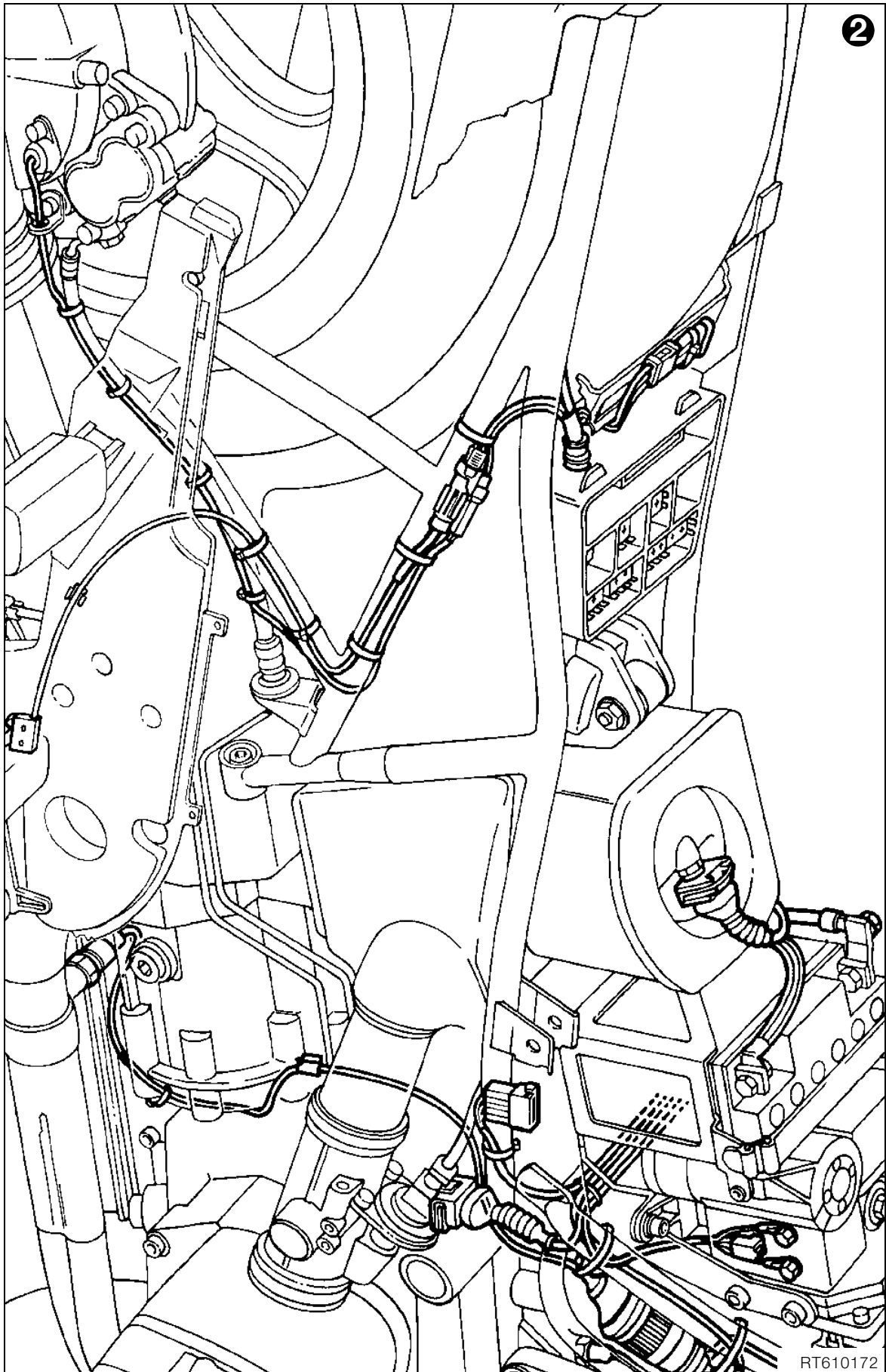
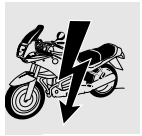

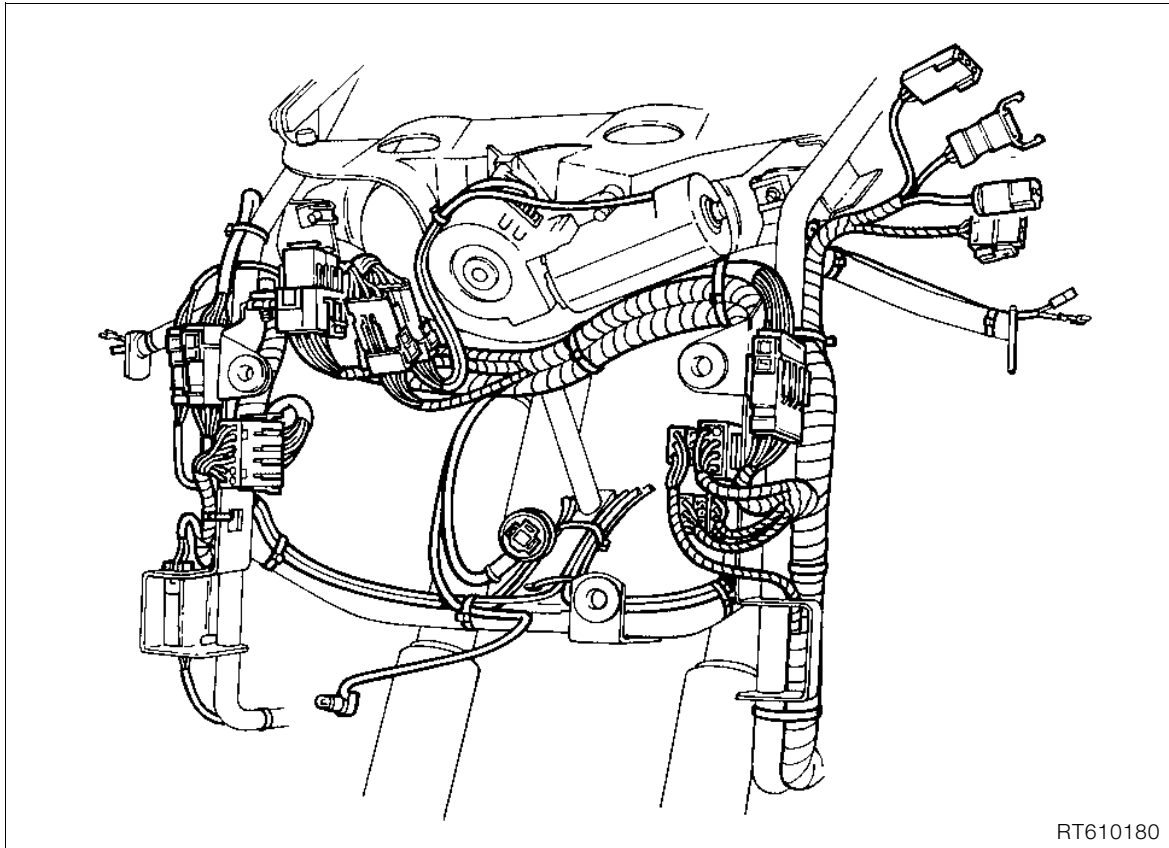

RT610180

[RT] Wiring harness at fairing holder

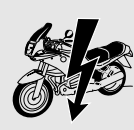

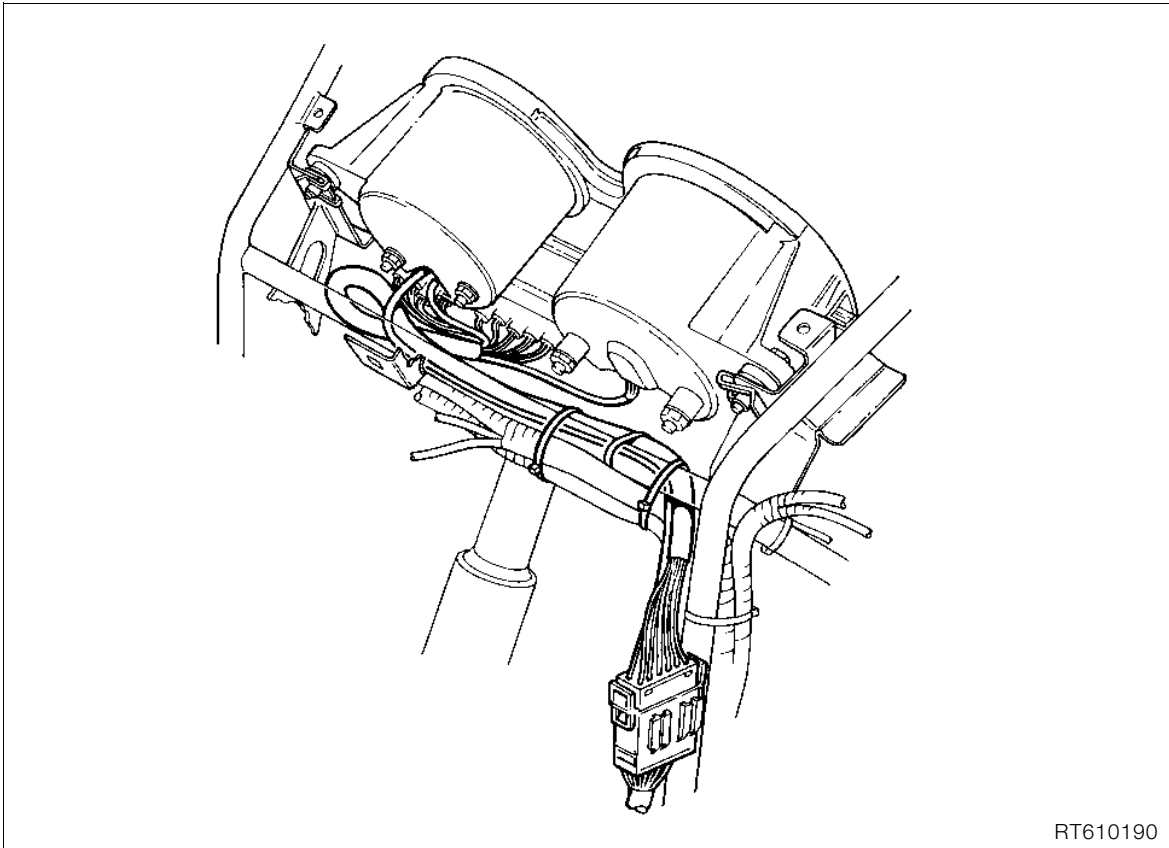

RT610190



[RT] Wiring harness at instrument cluster

[RS] Wiring harness View from left

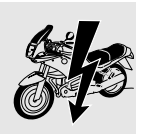
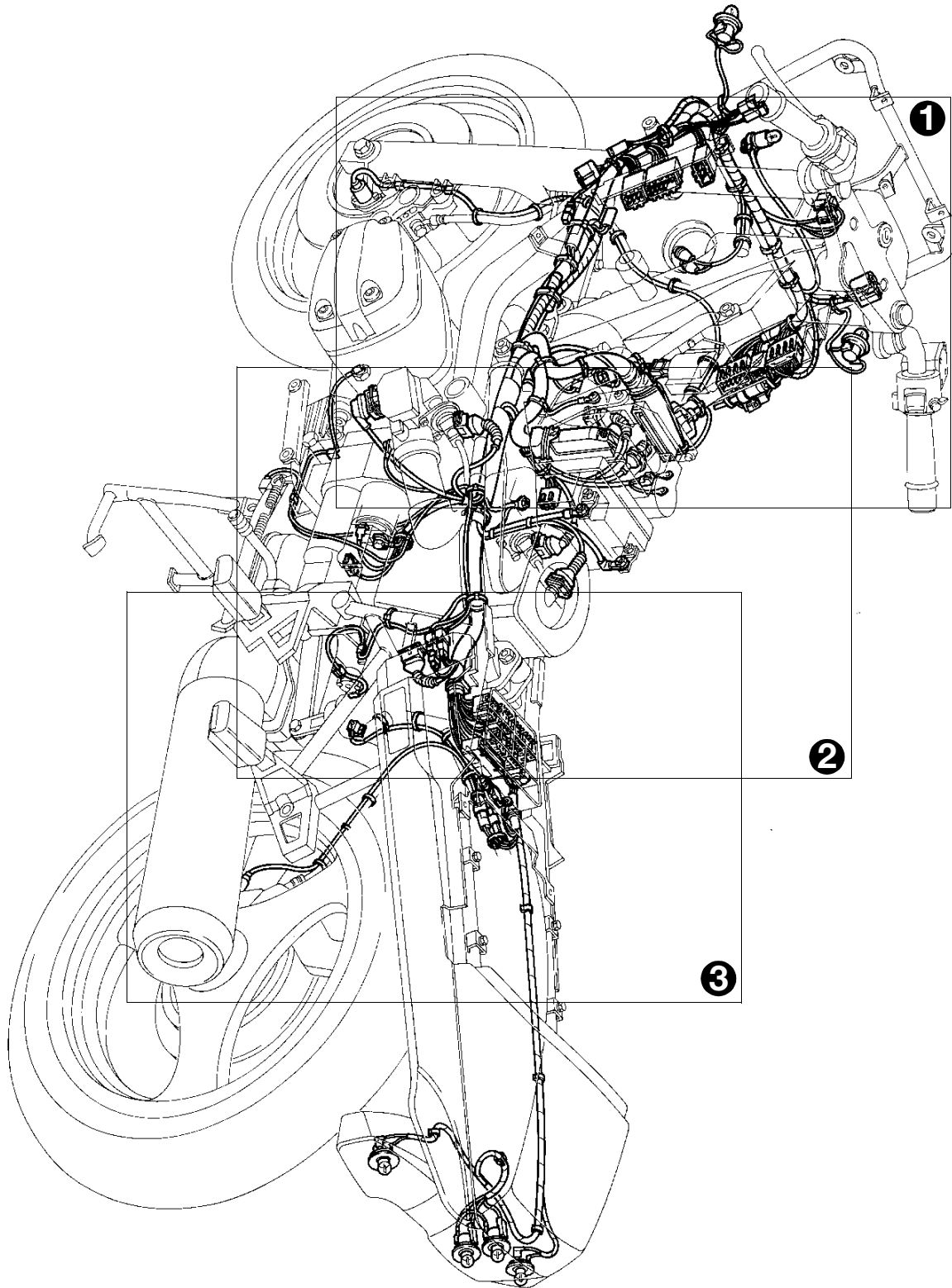

RS610040

61.21

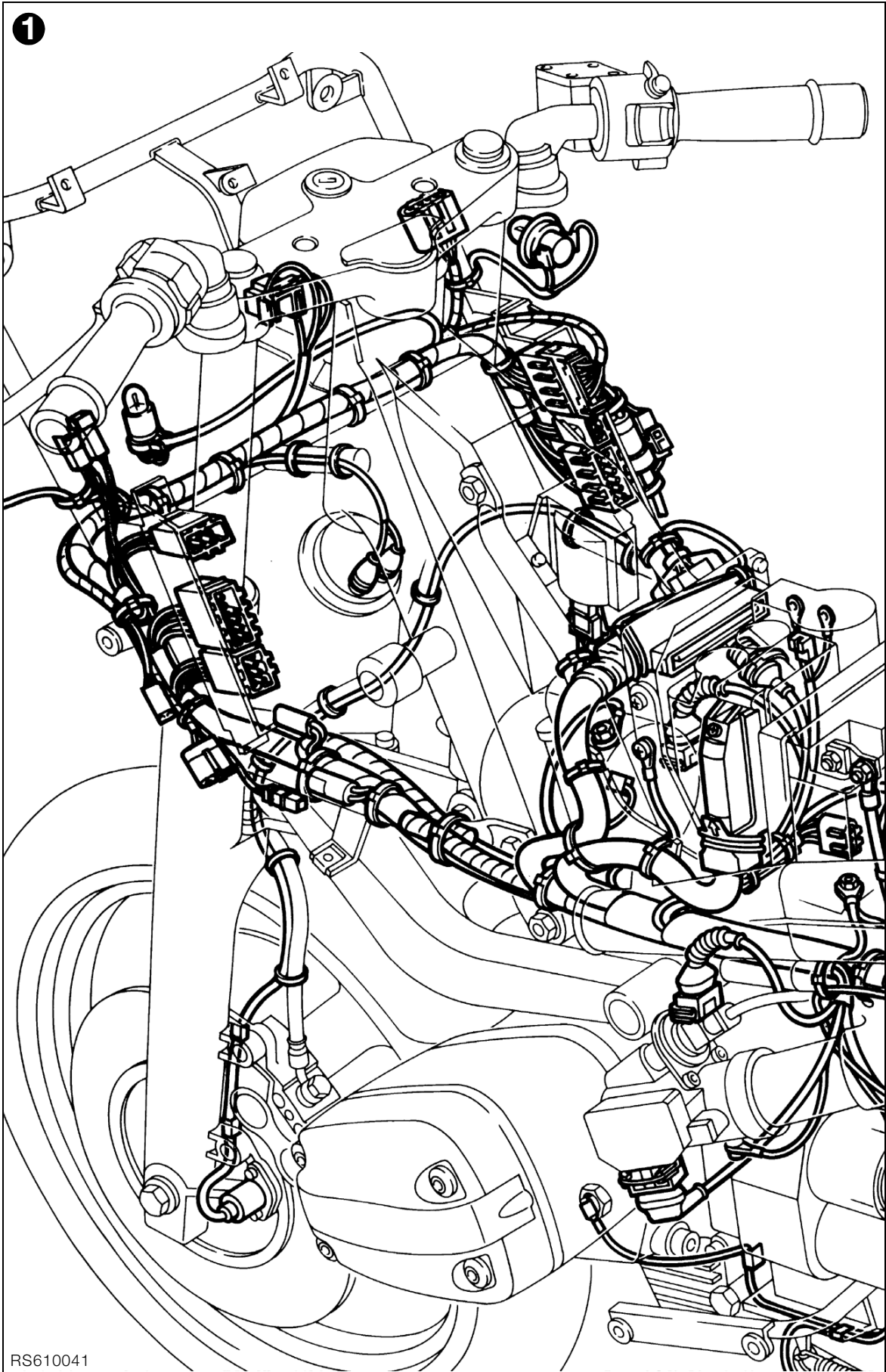

RS610041



2

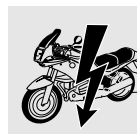
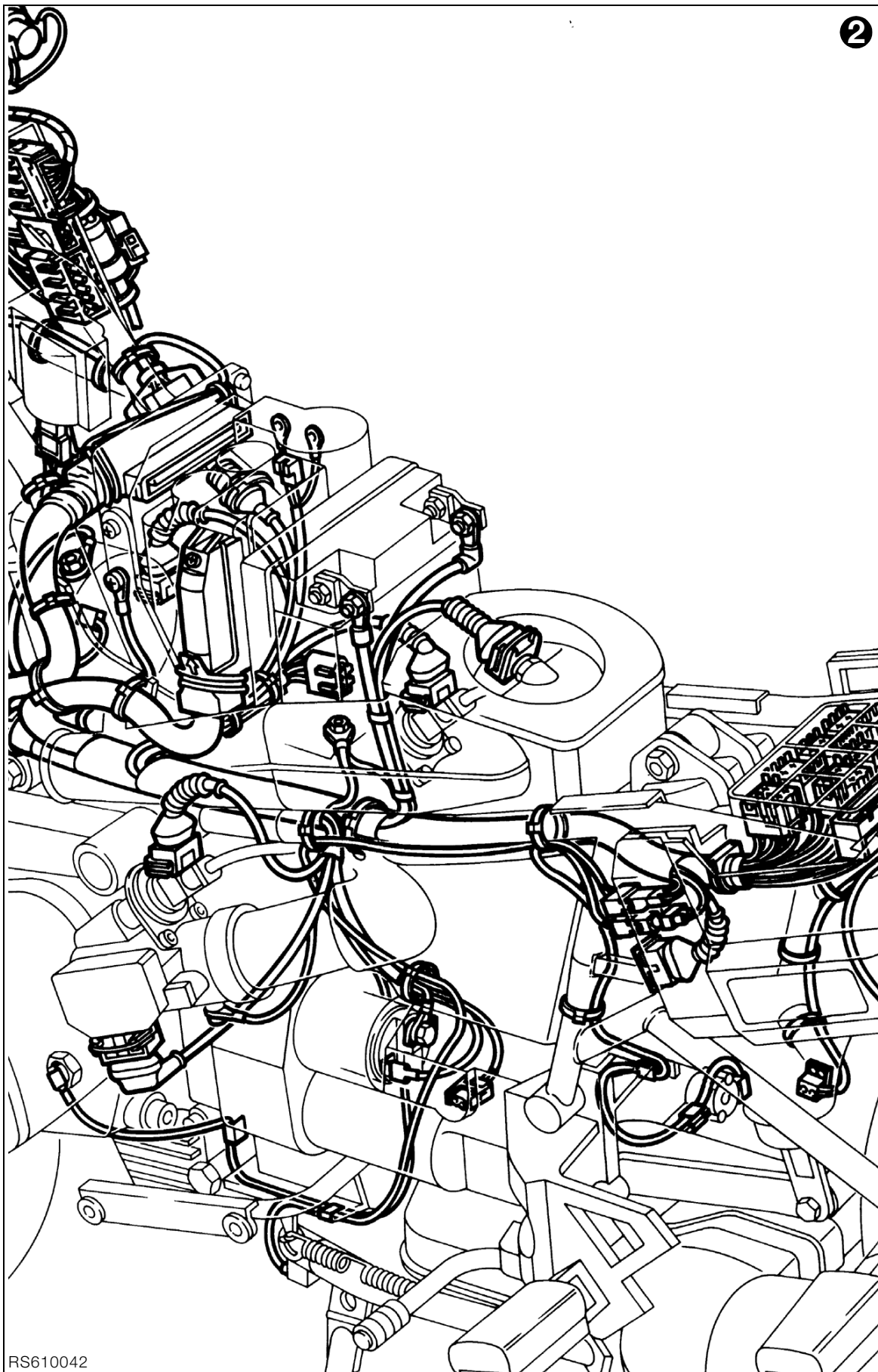

3

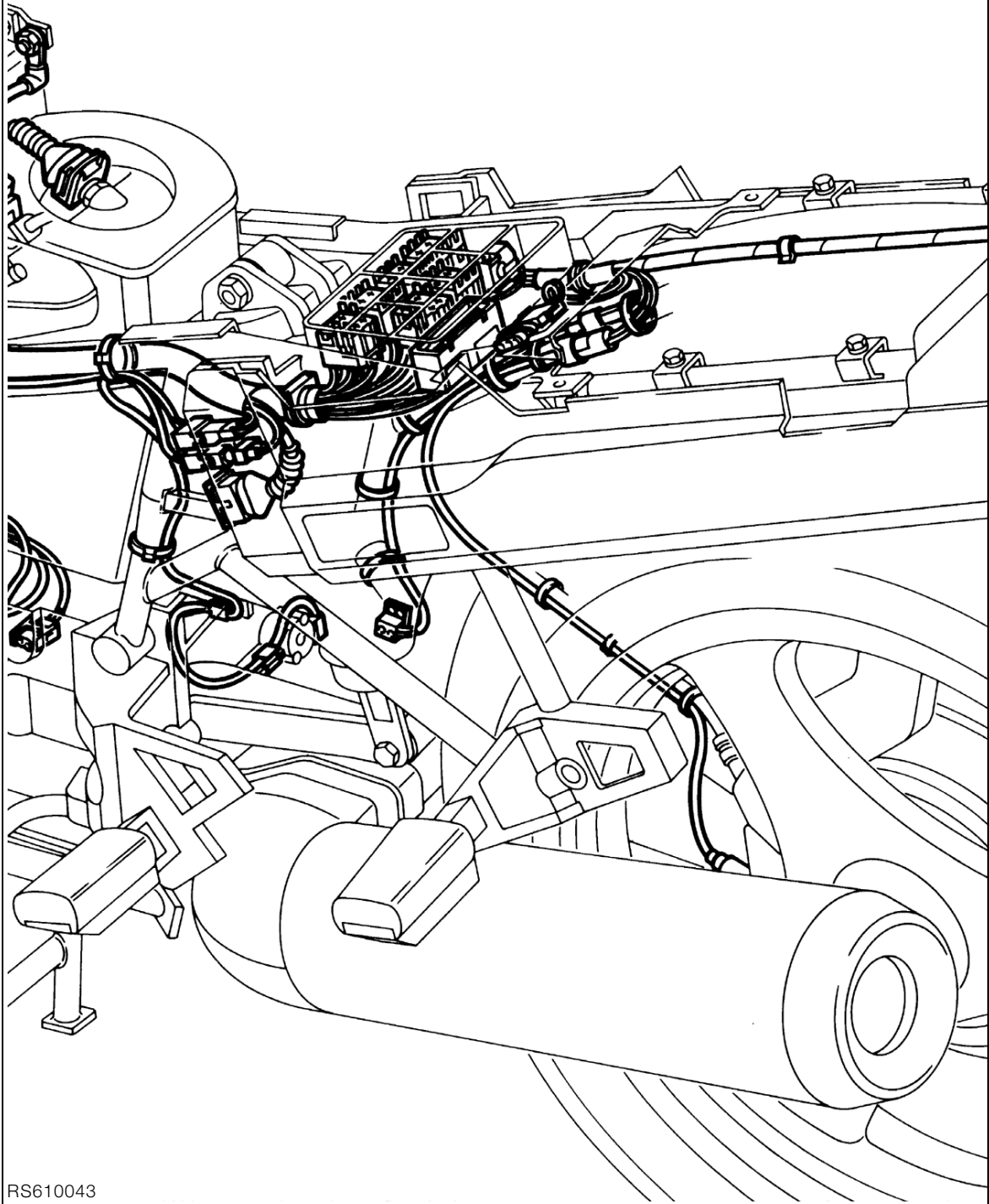

RS610043

[RS] Wiring harness View from right

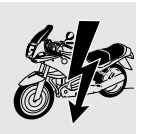
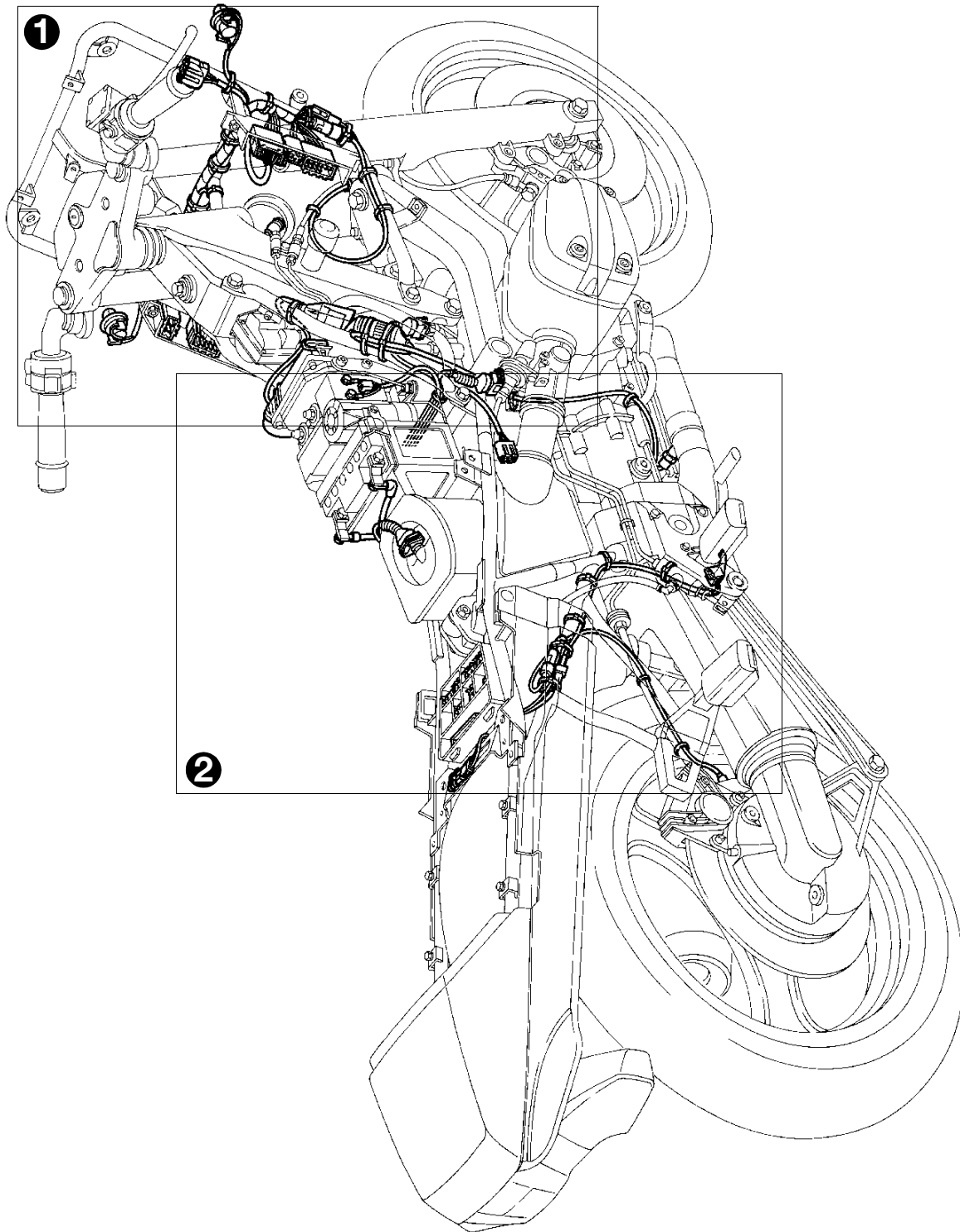

RS610030

61.25



1

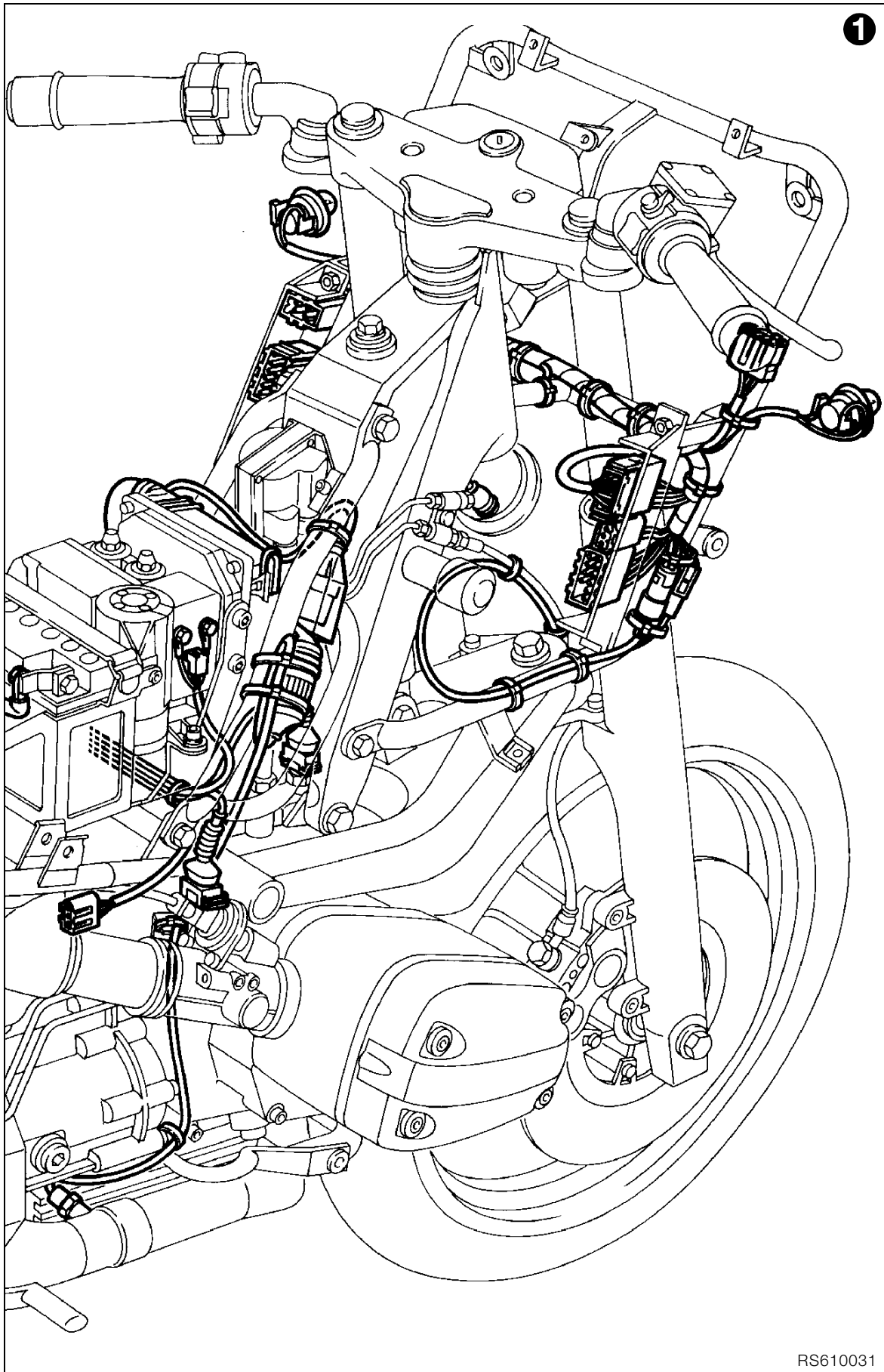

RS610031

2

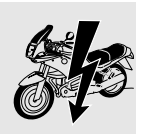
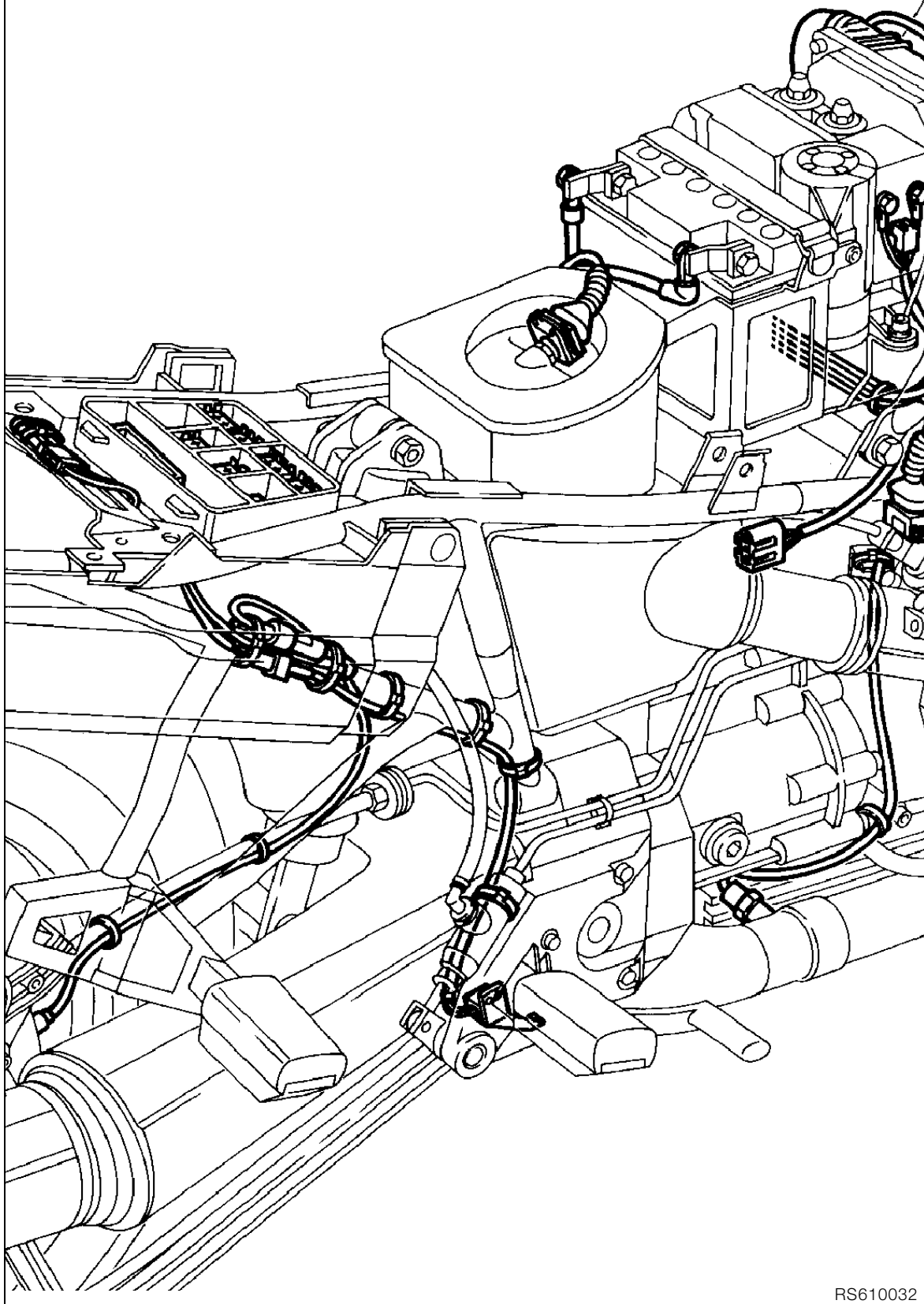

RS610032

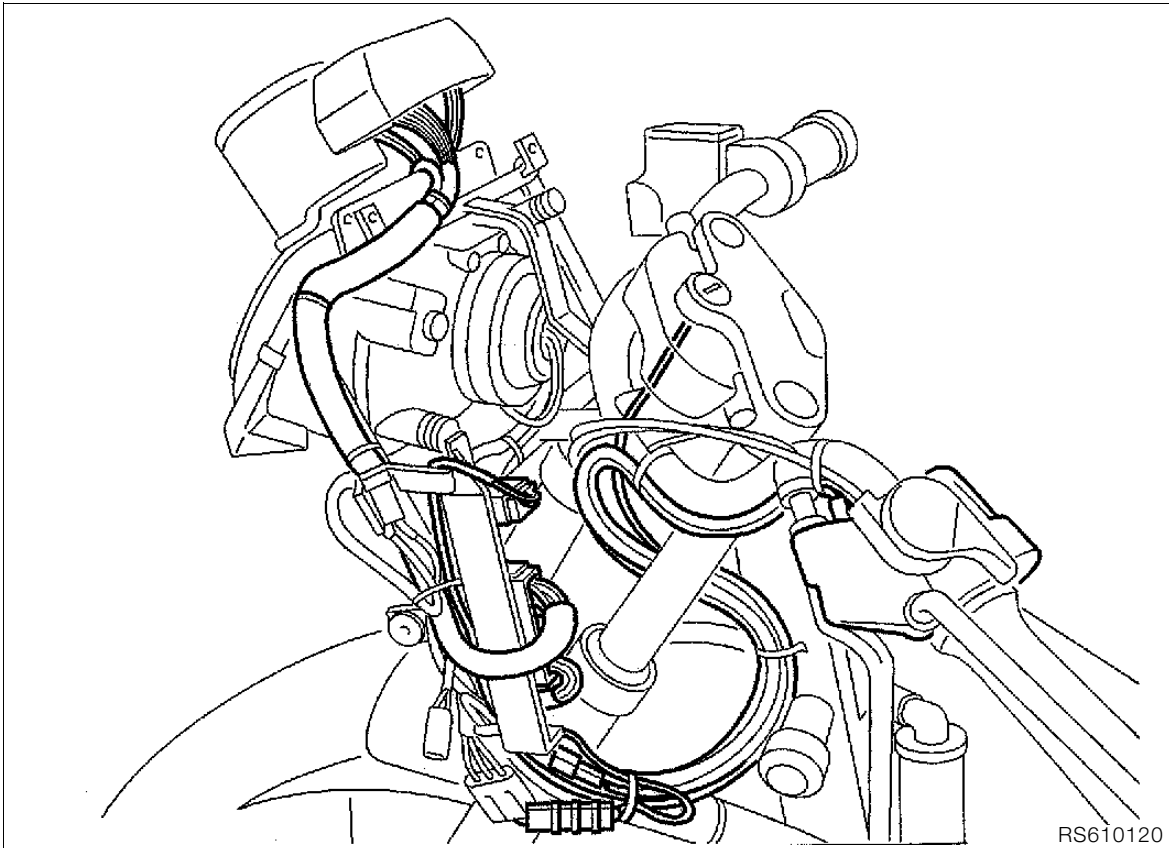

RS610120



[RS] Wiring harness at left switch unit

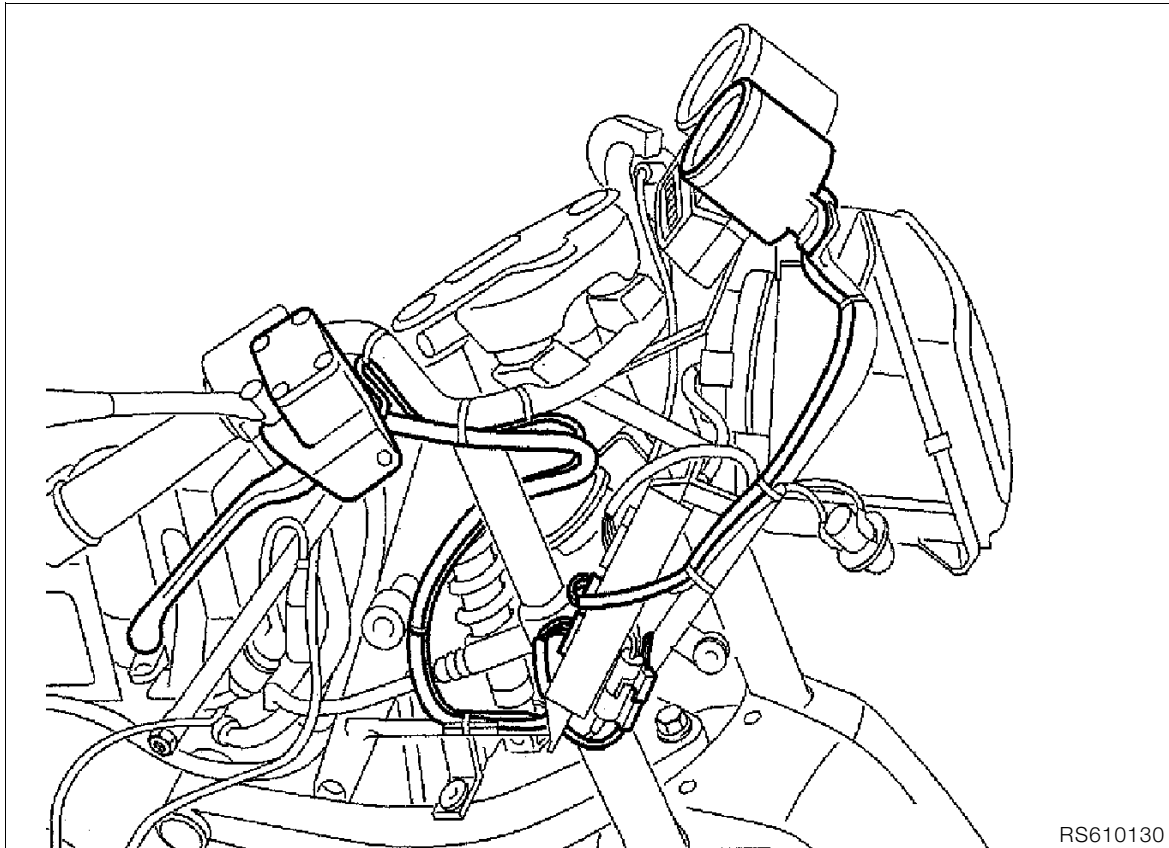

RS610130

[RS] Wiring harness at right switch unit



[GS] Wiring harness View from left

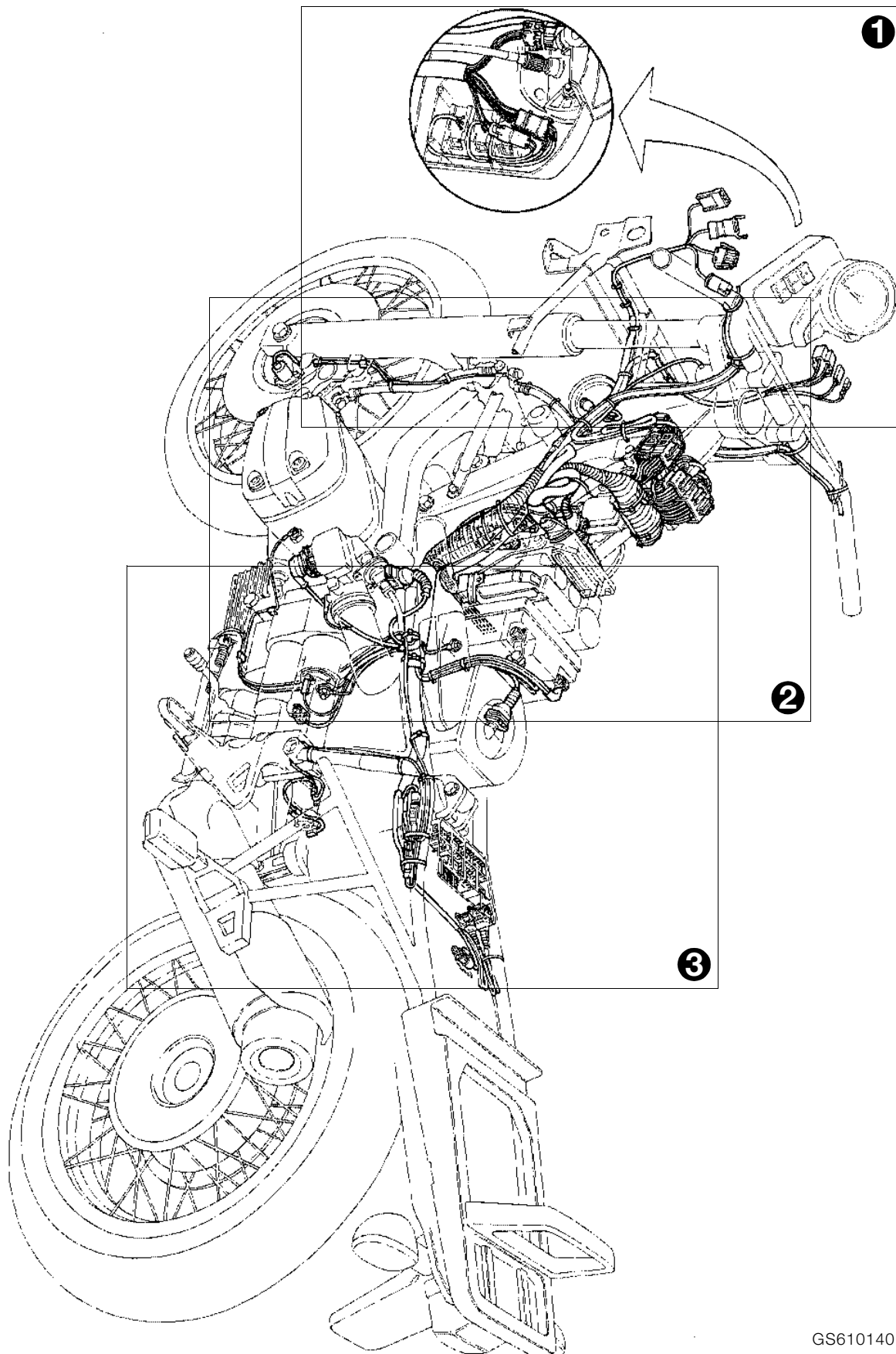

GS610140

1

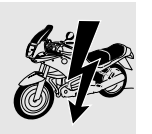
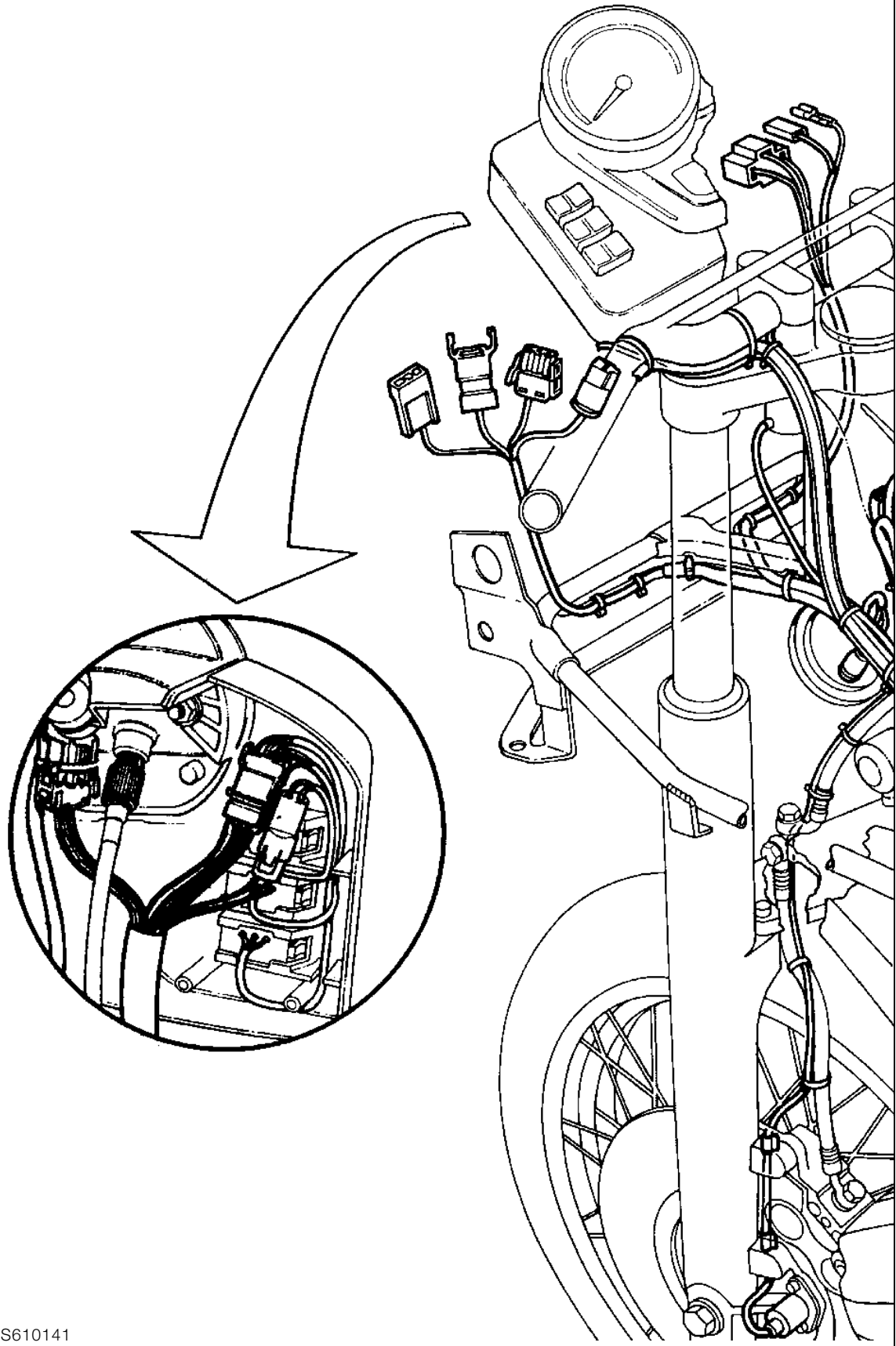

GS610141

2

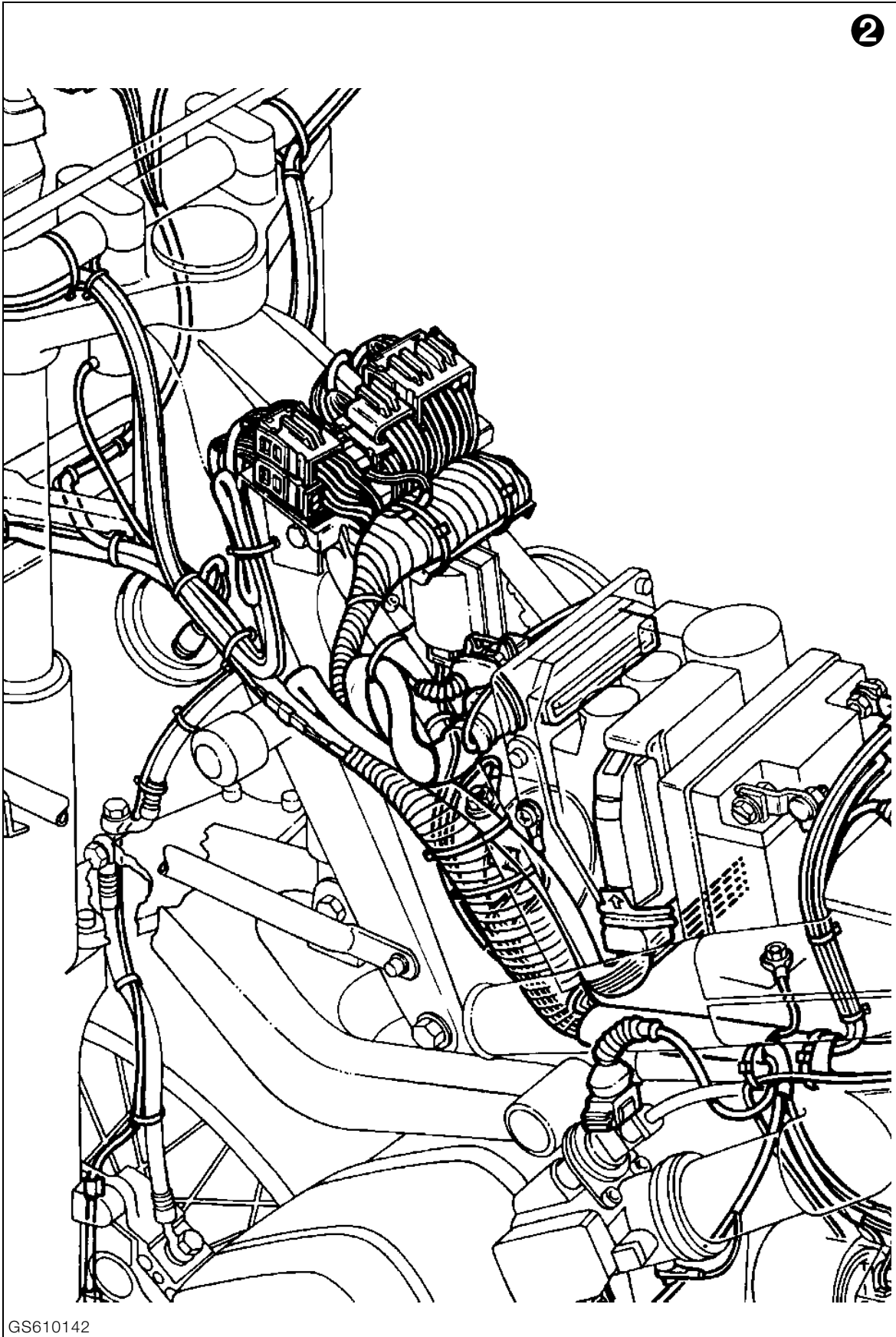

GS610142

3

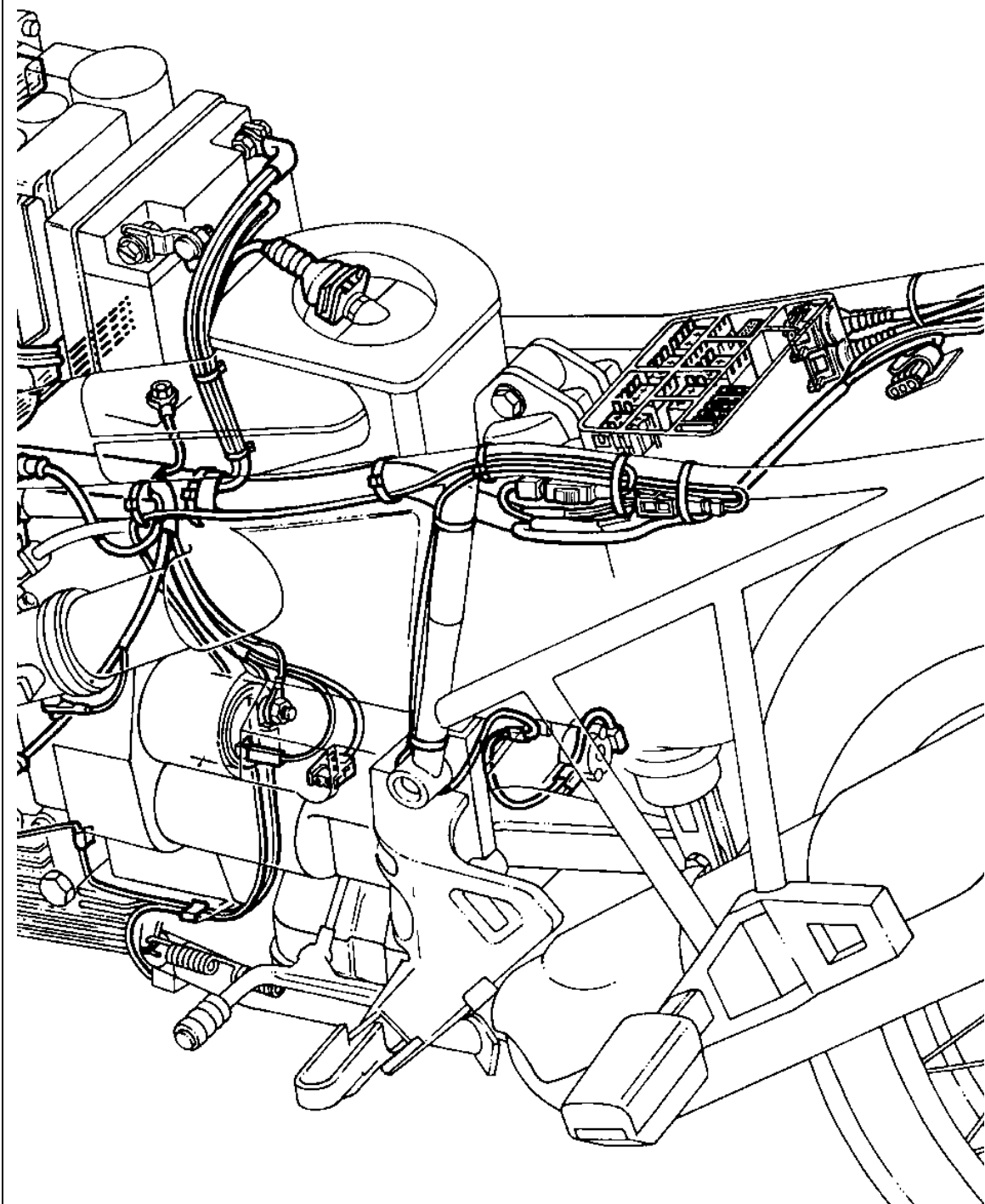

GS610143



[GS] Wiring harness View from right

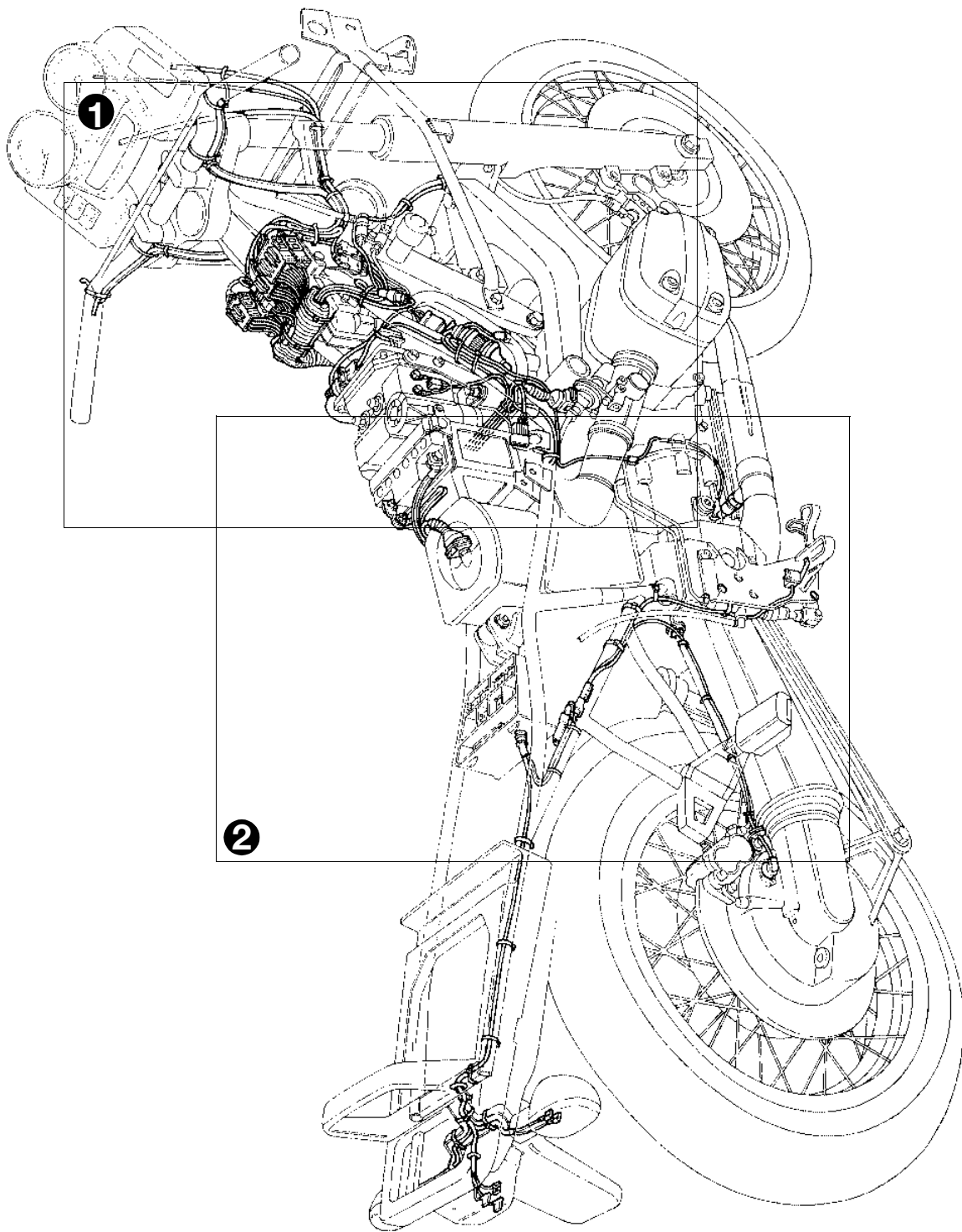

GS610150

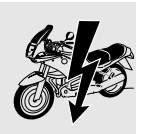
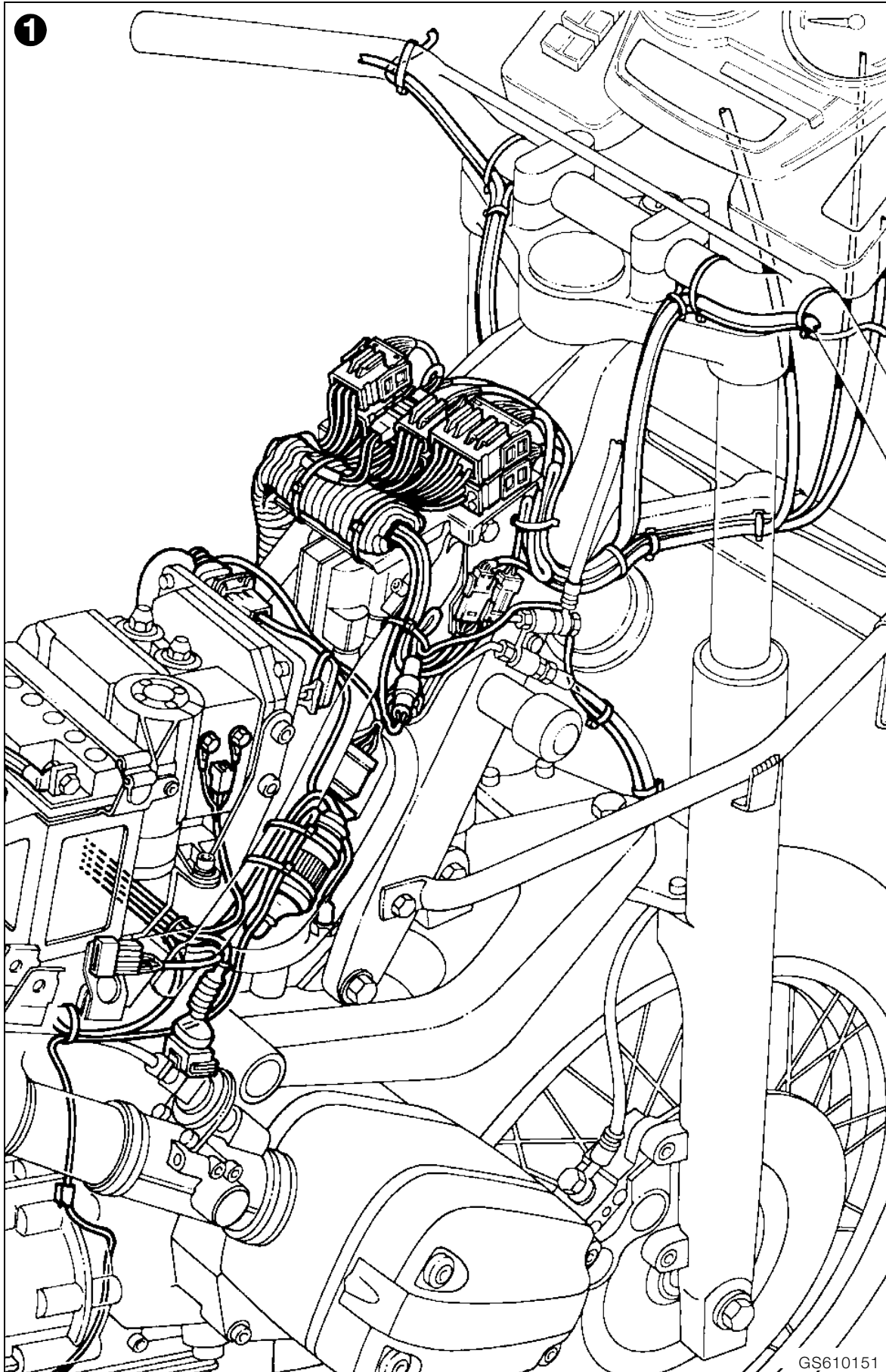

GS610151

2

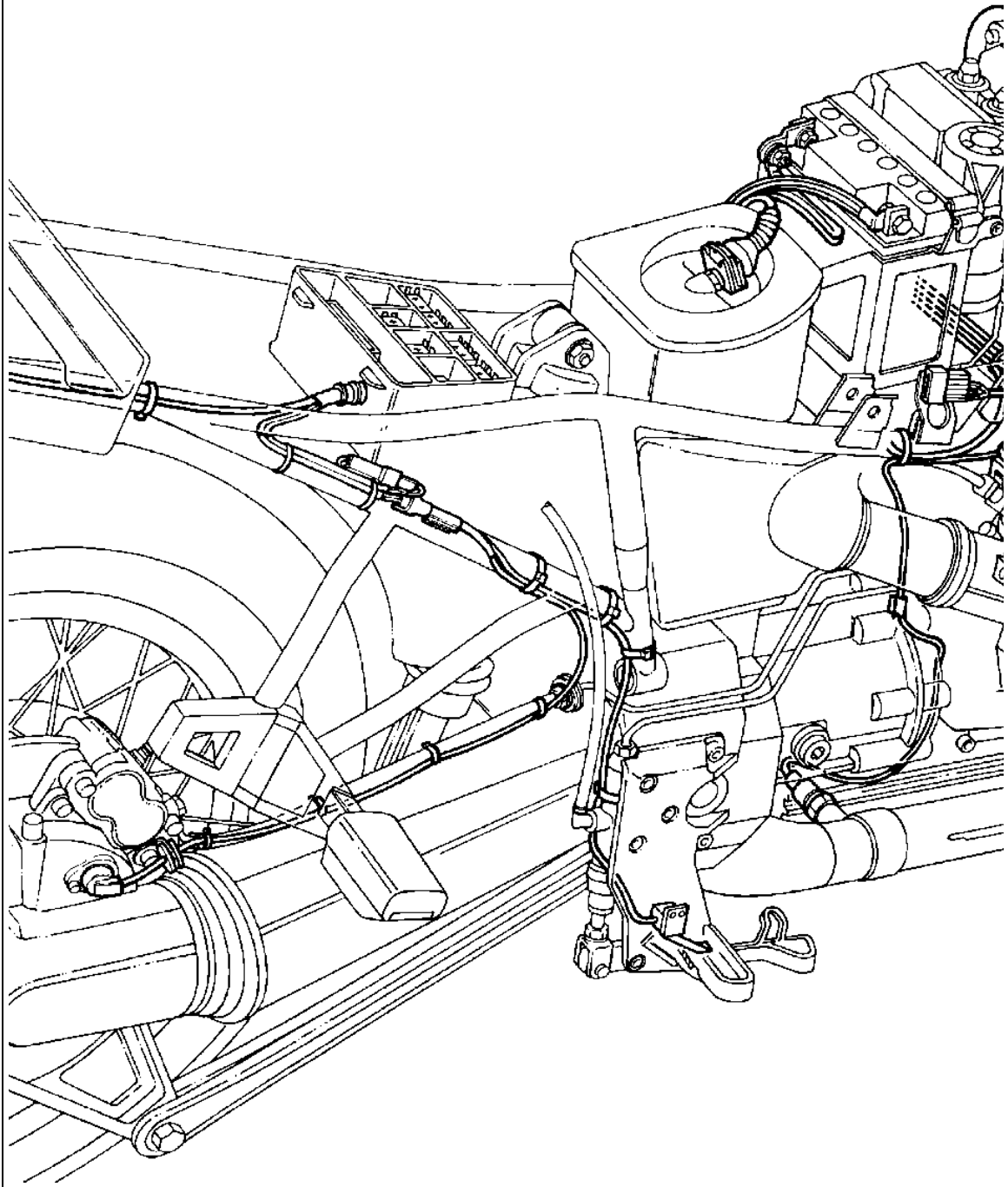

GS610152

## Removing and installing battery holder

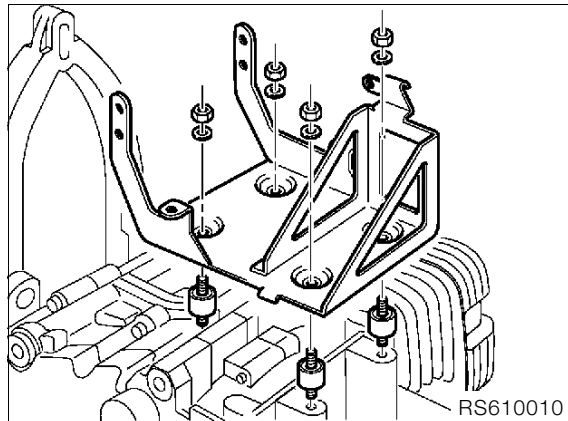

- Remove fuel tank.
- Remove battery.



### Caution:

Disconnect negative battery terminal first, then positive terminal.

Reconnect positive battery terminal first, then negative terminal.

- Remove Motronic control unit.
- **[ABS]** Remove control unit..
- En caso necesario, soltar el distribuidor de los cables de mando
- Remove the battery holder.
- Install in the reverse order of work.

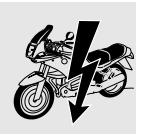

# 62 Instruments

<b>Contents</b>	<b>Page</b>
<b>Technical Data</b> .....	3
<b>[RT] Removing and installing instrument cluster</b> .....	7
<b>[RT] Dismantling and assembling instrument cluster</b> .....	7
<b>[RS] Removing and installing instrument cluster</b> .....	8
<b>[RS] Dismantling and assembling instrument cluster</b> .....	8
<b>[GS] Removing and installing instrument cluster</b> .....	9
<b>[GS] Dismantling and assembling instrument cluster</b> .....	9
<b>[R] Removing and installing instrument cluster</b> .....	10





Technical Data		R 1100 RS
<b>Instrument cluster</b>		
Telltale for turn indicators/high beam		A 14 V 3 W
Instrument lighting / telltales		A 12 V 1,7 W
<b>Speedometer drive</b>		
Speedometer drive ratio		I = 2,6



Technical Data		R 1100 RT
<b>Instrument cluster</b>		
Telltales for turn indicators/high beam		A 14 V 3 W
Instrument lighting / telltales		A 12 V 1,7 W
<b>Speedometer drive</b>		
Speedometer drive ratio		I = 2,6





<b>Technical Data</b>	<b>R 850 GS</b>	<b>R 1100 GS</b>
<b>Instrument cluster</b>		
Telltales for turn indicators/high beam	A 14 V 3 W	A 14 V 3 W
Instrument lighting / telltales	A 12 V 1,7 W	A 12 V 1,7 W
<b>Speedometer drive</b>		
Speedometer drive ratio	I = 3,0	I = 3,0



Technical Data	R 850 R	R 1100 R
<b>Instrument cluster</b>		
Telltales for turn indicators/high beam	A 14V 3W	A 14V 3W
Instrument lighting / telltales	A 12V 1,7W	A 12V 1,7W
<b>Speedometer drive</b>		
Speedometer drive ratio	Cast wheel	I = 2,6
	Spoked wheel	I = 3,0



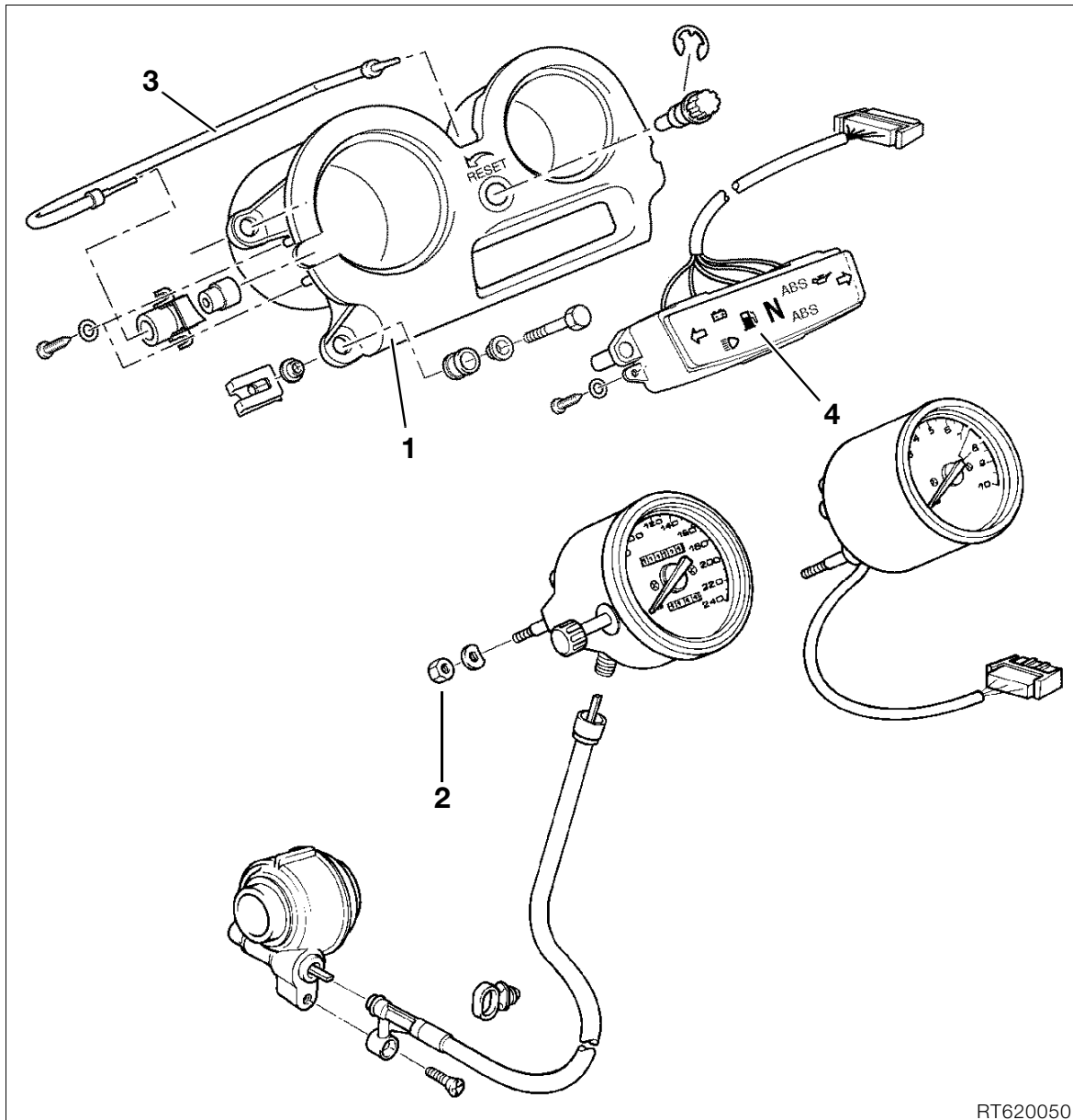

RT620050

### [RT] Removing and installing instrument cluster

- Remove dualseat.
- Remove mirrors.
- Remove side sections of fairing.
- Remove inner fairing panel.
- Remove windshield.
- Remove upper section of fairing.
- Detach speedometer shaft.
- Detach instrument cluster (1) and lift out of mount.
- Disconnect plugs.
- Install in the reverse order of work.

### [RT] Dismantling and assembling instrument cluster

- Unscrew threaded connections at instruments (2).
- Detach trip distance recorder reset shaft (3) from speedometer.
- Pull off instrument lighting.
- Remove monitor unit (4).
- Assemble in the reverse order of work.



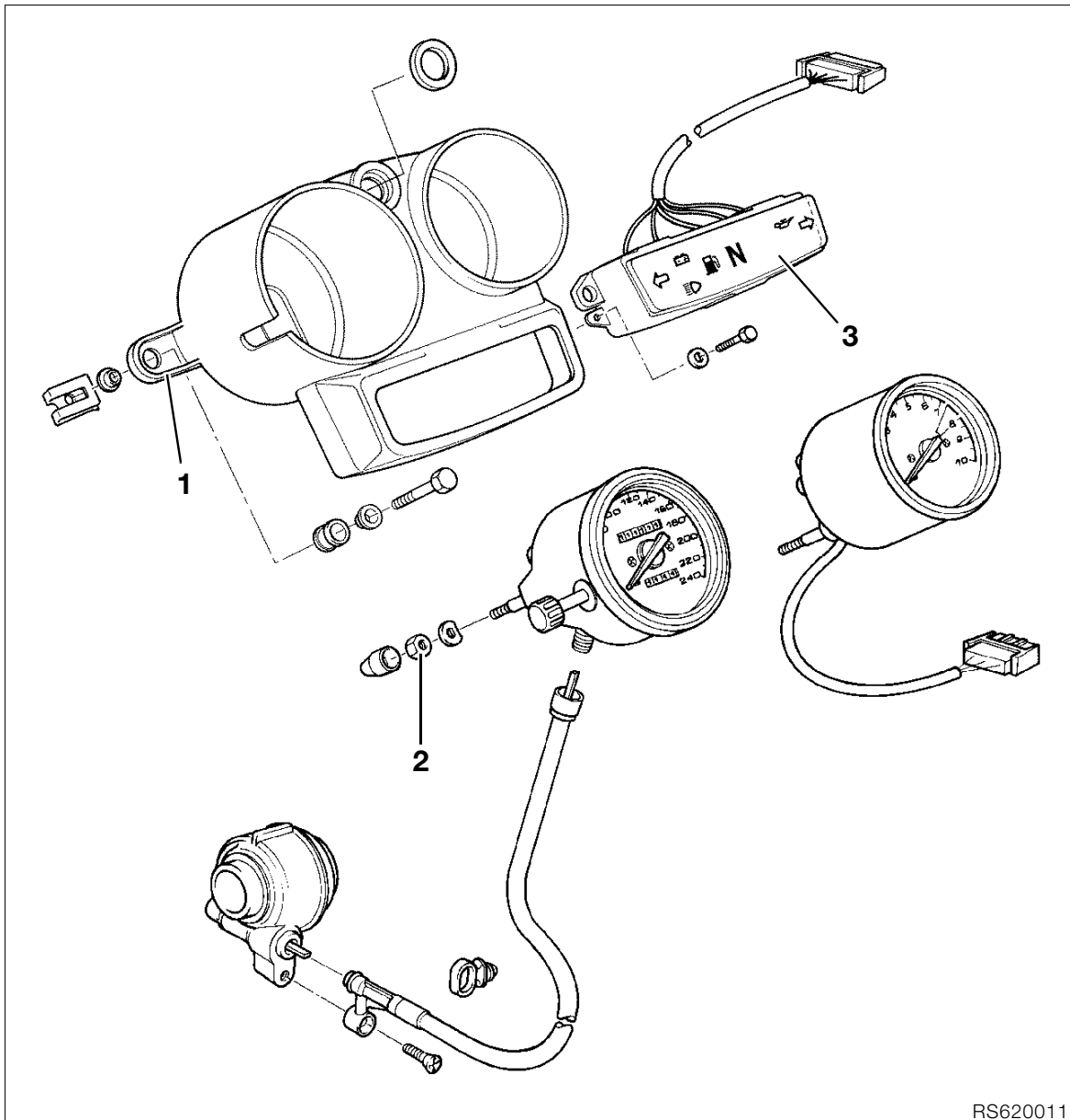

RS620011

### [RS] Removing and installing instrument cluster

- Remove inner cover for trim.
- **[Windshield adjustment]** Turn windshield adjuster shaft to left/detach.
- Detach instrument cluster (1) and pull up away from mount.
- Detach speedometer shaft.
- Disconnect plugs.
- Install in the reverse order of work.

### [RS] Dismantling and assembling instrument cluster

- Unscrew threaded connections at instruments (2).
- Pull off instrument lighting.
- Remove monitor unit (3).
- Assemble in the reverse order of work..



#### Caution:

When installing the speedometer, note the grommet on the trip distance recorder reset button.

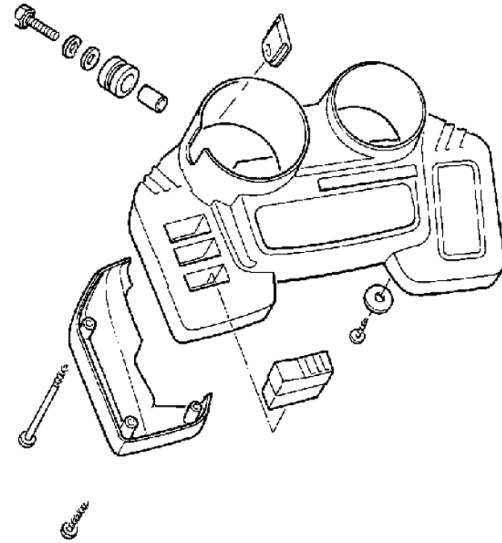
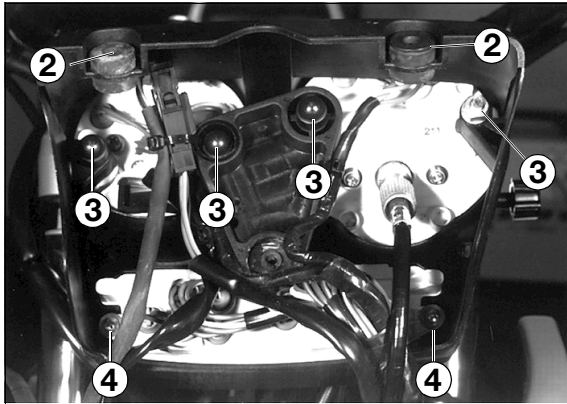

GS620030

### [GS] Removing and installing instrument cluster

- Remove windshield.

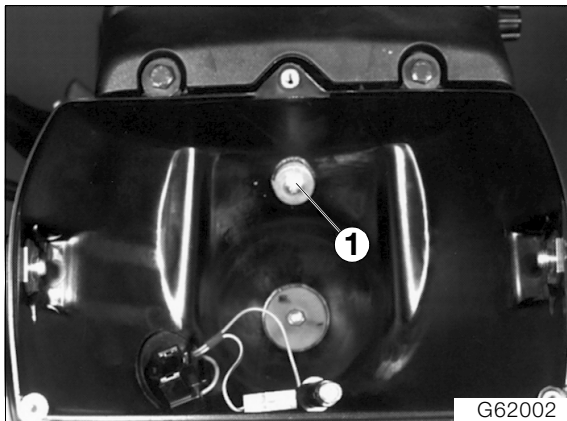

- Remove headlight housing/detach instrument cluster mount on inside of headlight housing (1).
- Detach instrument cluster (2).
- Detach speedometer shaft.
- Remove left cover.
- Disconnect plugs.
- Install in the reverse order of work.

### [GS] Dismantling and assembling instrument cluster

- Unscrew threaded connections (3) at instrument cluster.
- Pull off instrument lighting.
- Remove monitor unit (4).
- Remove telltales.
- Assemble in the reverse order of work.



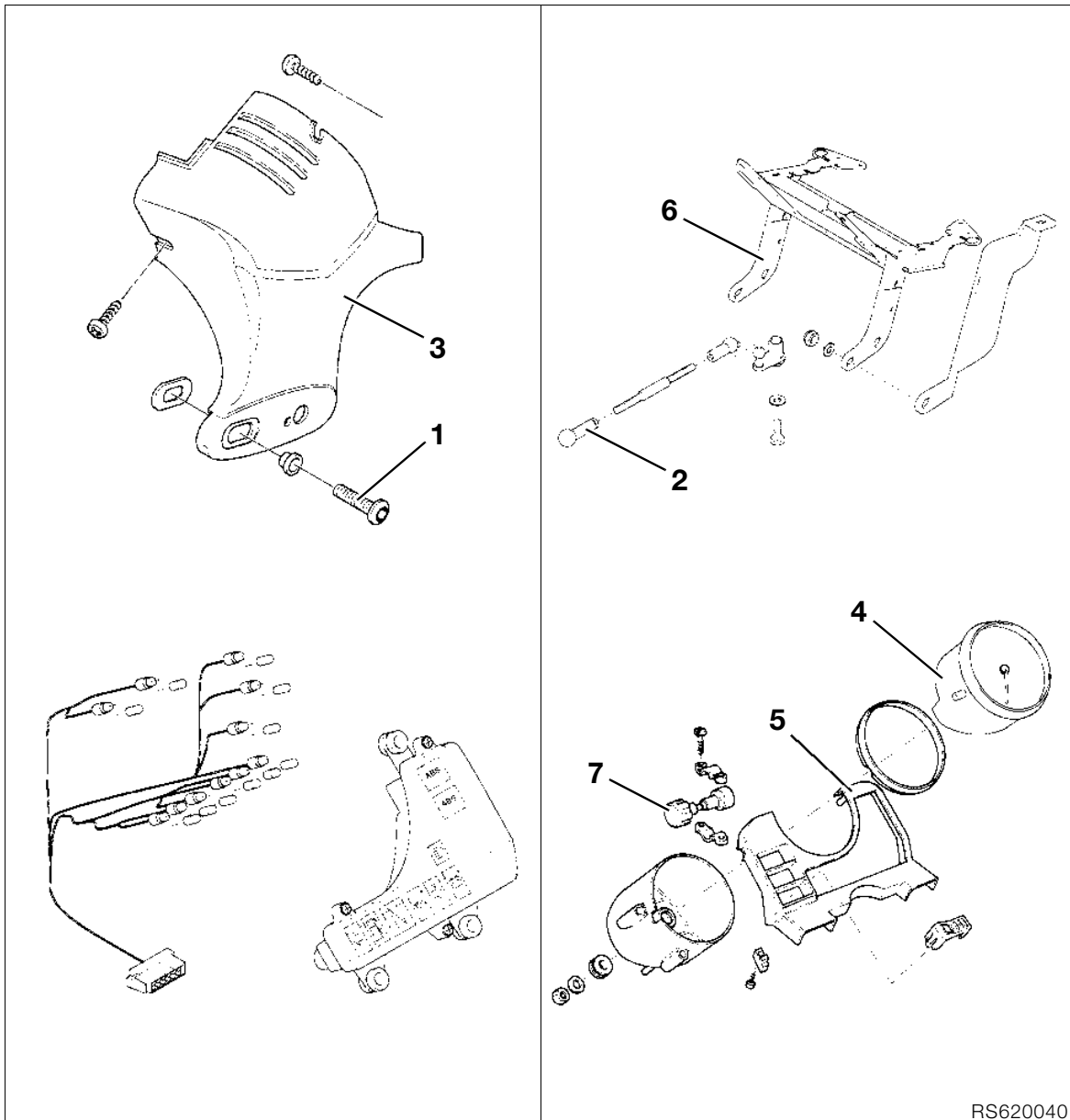

RS620040

## [R] Removing and installing instrument cluster

- Remove headlight mount (1) and adjuster (2).
- Remove indicators.
- Remove left (3) and right trims from instrument cluster.
- Remove speedometer reset extension (7).
- Remove speedometer (4).
- Remove upper trim (5) from instrument cluster.
- Pull off instrument lighting and telltales.
- Detach cable strap at headlight.
- Remove handlebar.
- Remove headlight holder (6).
- Assemble in the reverse order of work.

# 63 Lights

<b>Contents</b>	<b>Page</b>
<b>Technica Data</b> .....	3
<b>[RT] Removing and installing headlight</b> .....	7
Adjusting headlight .....	7
<b>[RS] Removing and installing headlight</b> .....	8
Adjusting headlight .....	8
<b>[GS] Removing and installing headlight</b> .....	9
Adjusting headlight .....	10
<b>[GS] Removing and installing front flashing turn indicator</b> .....	10
<b>[R] Removing and installing headlight</b> .....	10
Adjusting headlight .....	10



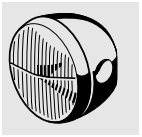



Technica Data		R 1100 RS
Headlight		rectangular, with halogen bulb and manual beam throw adjustment
<b>Bulbs</b>		
High beam/low beam		H 4, 55/60 W halogen, asymmetric
Parking light		12 V/5 W
Rear light		12 V/10 W
Brake light		12 V/21 W
Flashing turn indicator		12 V/21 W



Technica Data		R 1100 RT
Headlight		rectangular, with halogen bulb
<b>Bulbs</b>		
High beam/low beam		H 4, 55/60 W halogen, asymmetric
Parking light		12 V/5 W
Rear light		12 V/10 W
Brake light		12 V/21 W
Flashing turn indicator		12 V/21 W



<b>Technica Data</b>	<b>R 850 GS</b>	<b>R 1100 GS</b>
Headlight	rectangular, with halogen bulb	rectangular, with halogen bulb
<b>Bulbs</b>		
High beam/low beam	H 4, 55/60 W halogen, asymmetric	H 4, 55/60 W halogen, asymmetric
Parking light	12 V/4 W	12 V/4 W
Rear light	12 V/10 W	12 V/10 W
Brake light	12 V/21 W	12 V/21 W
Flashing turn indicator	12 V/21 W	12 V/21 W



<b>Technica Data</b>	<b>R 850 R</b>	<b>R 1100 R</b>
Headlight	circular, with halogen	circular, with halogen
<b>Bulbs</b>		
High beam/low beam	H 4, 55/60 W halogen, asymmetric	H 4, 55/60 W halogen, asymmetric
Parking light	12V/4W	12V/4W
Rear light	12V/10W	12V/10W
Brake light	12V/21W	12V/21W
Flashing turn indicator	12V/21W	12V/21W



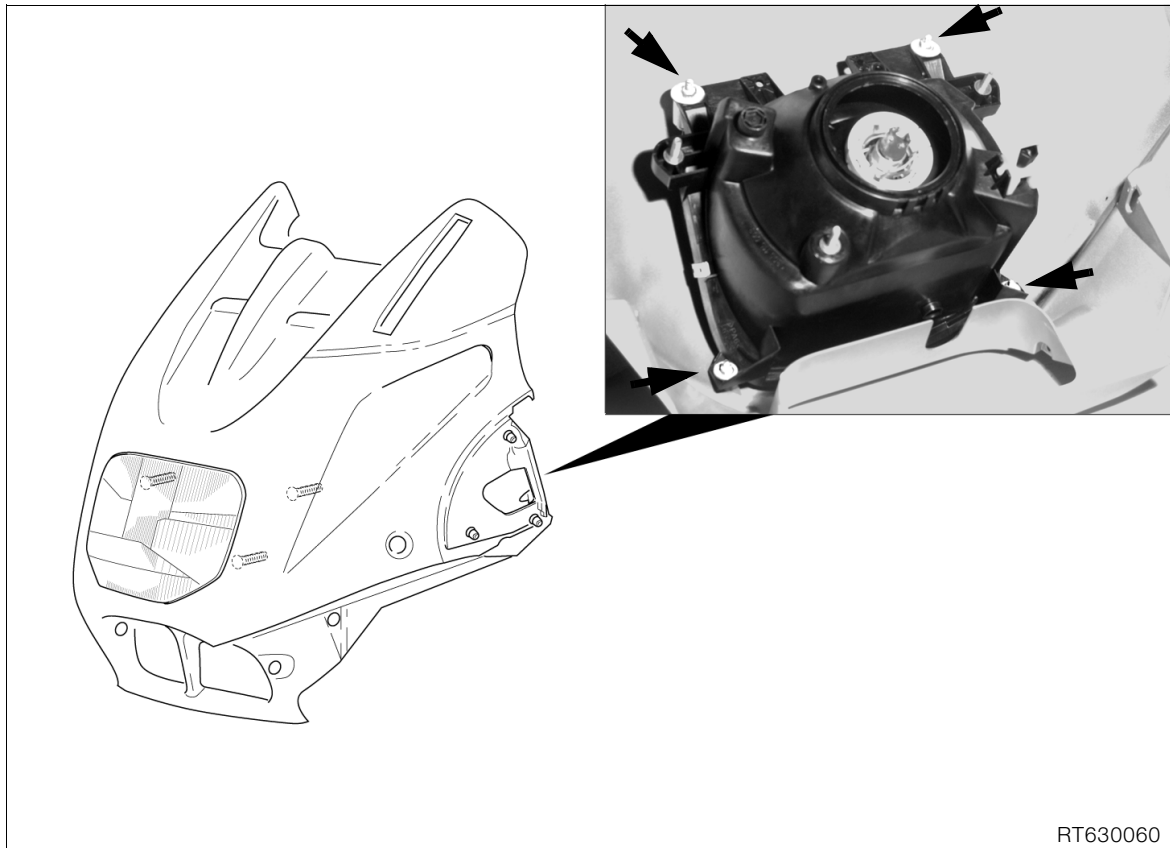

RT630060

**[RT] Removing and installing headlight**

**Adjusting headlight**



**Caution:**

Switch off ignition.  
 Disconnect ground (earth) lead from battery.  
 Insulate ground (earth) lead.

- Remove dualseat.
- Remove mirrors.
- Remove side trim.
- Remove inner cover for trim.
- Detach windshield.
- Pull off plug at headlight.
- Remove upper section of fairing.
- Remove headlight retaining screws (arrows).
- Remove headlight.
- Install in the reverse order of work.



**Caution:**

Do not touch inner surface of reflector or bulbs with bare hands.

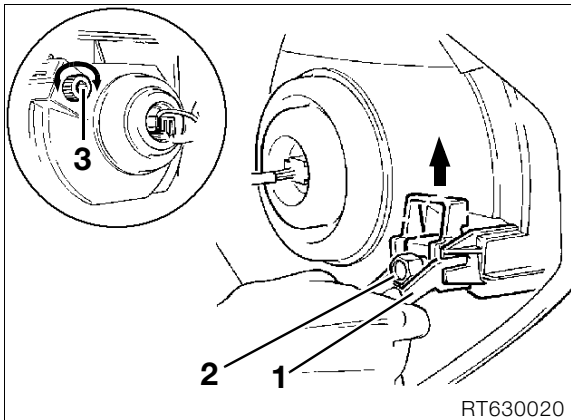

RT630020



- Move swivel lever (1) to top position.
- Correct the headlight beam throw with adjusting screw (2).

**Counter-clockwise rotation:** ..... longer

**Clockwise rotation:** ..... shorter

**Adjustment distance:**

..... -15 cm (5.91 in) at a distance of 10 m (32.81 ft)

- Adjust side angle with adjusting screw (3).

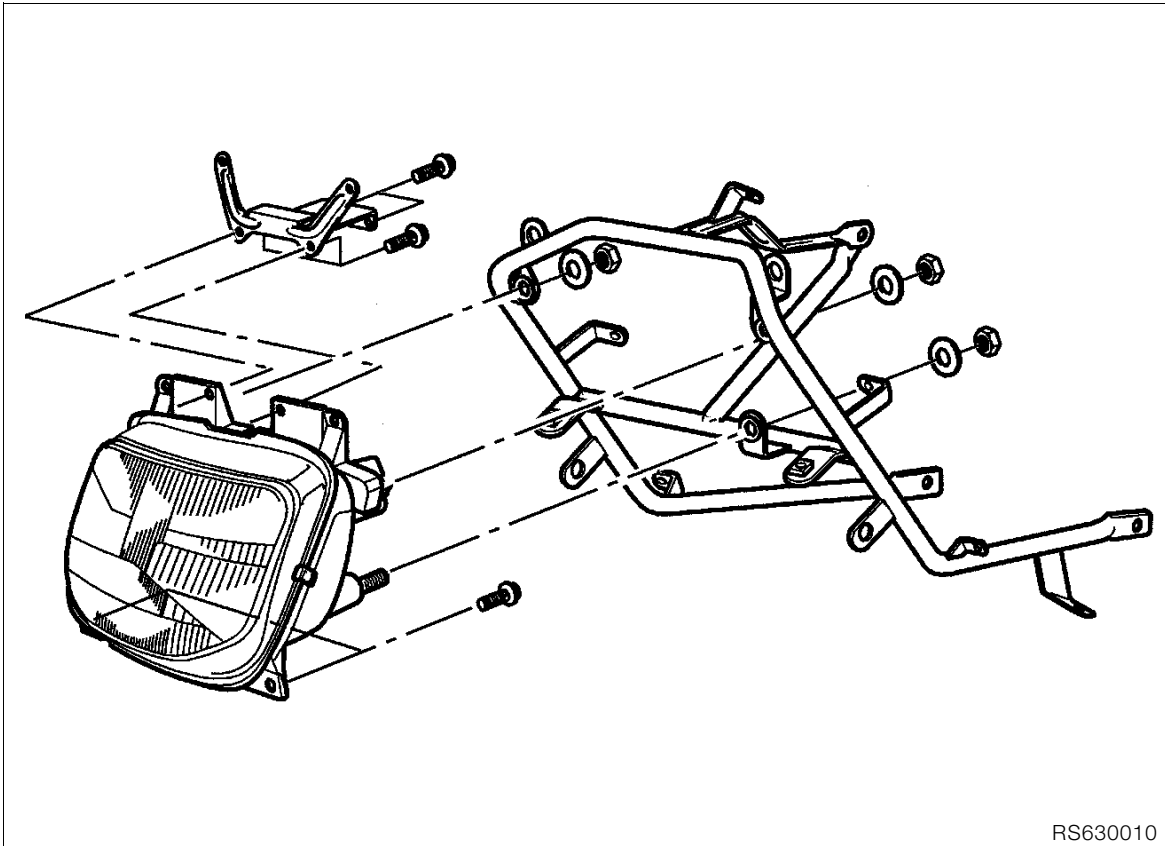

RS630010

**[RS] Removing and installing headlight**

**Adjusting headlight**



**Caution:**

Switch off ignition.  
Disconnect ground (earth) lead from battery.  
Insulate ground (earth) lead.



- Remove side trim.
- Remove inner cover for trim.
- Detach windshield.
- Detach instrument bracket.
- Detach front section of trim.
- Detach headlight at fairing holder.
- Detach headlight at front section of fairing.
- Detach windshield holder at headlight.
- Remove headlight.
- Install in the reverse order of work.



**Caution:**

Do not touch inner surface of reflector or bulbs with bare hands.

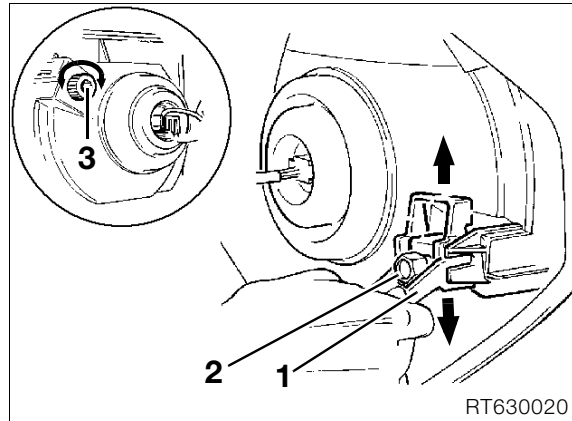

RT630020

- Move swivel lever (1) to top position.
- Correct headlight beam throw with adjusting screw (2).

**Counter-clockwise rotation:** .....longer  
**Clockwise rotation:** .....shorter

**Adjustment distance:**  
..... -15 cm (5.91 in) at a distance of 10 m (32.81 ft)

- Adjust side angle with adjusting screw (3).

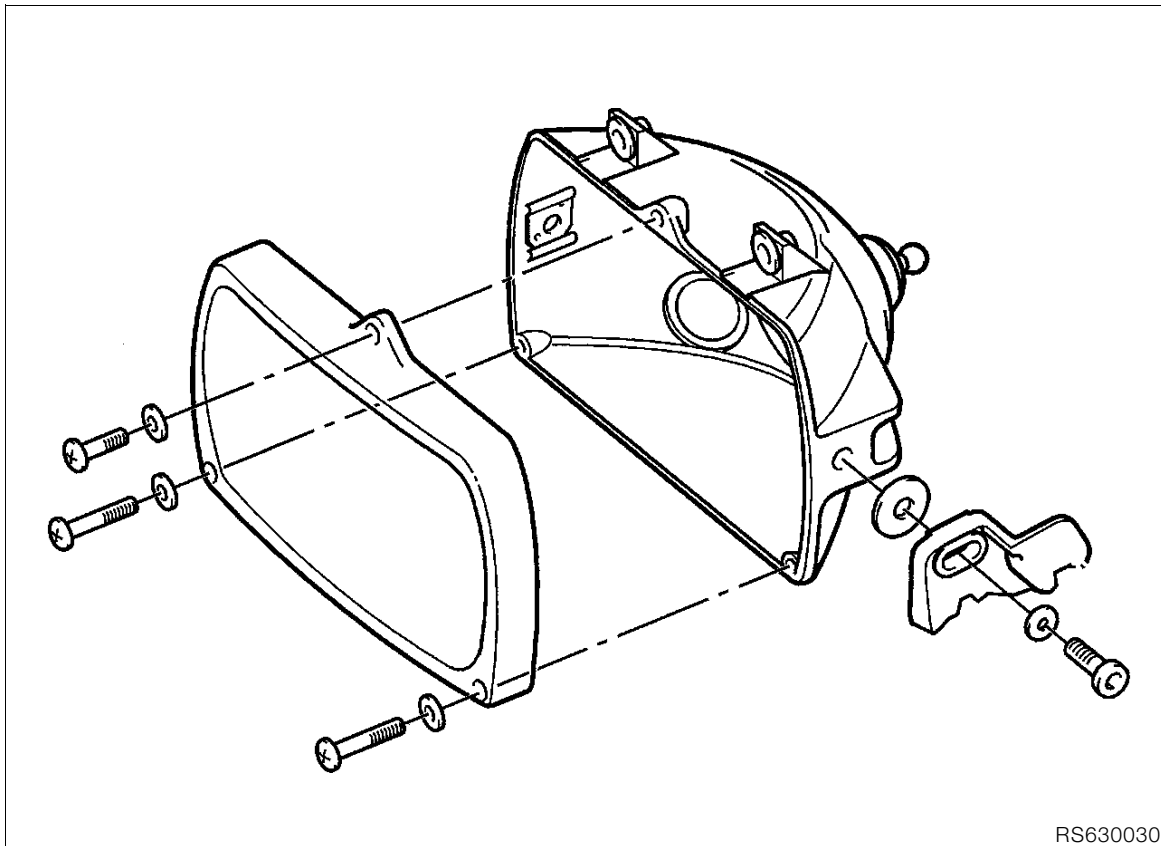

## [GS] Removing and installing headlight



### Caution:

Switch off ignition.  
Disconnect ground (earth) lead from battery.  
Insulate ground (earth) lead.

- Remove windshield.
- Remove headlight insert.



### Caution:

Do not touch inner surface of reflector or bulbs with bare hands.

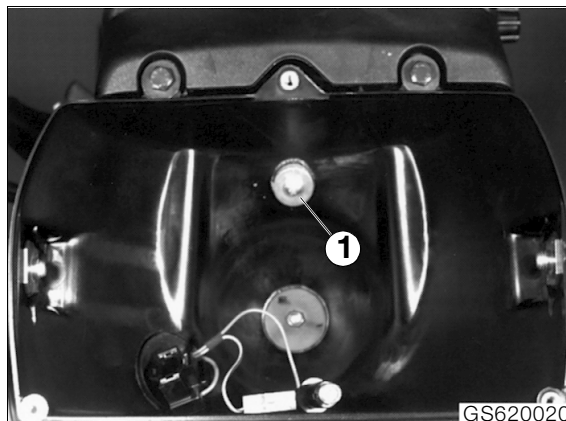

- Detach instrument cluster.



### Note:

The center retaining screw (1) is in the headlight housing.

- Unfasten headlight beam throw adjuster.
- Remove headlight housing.

## Adjusting headlight

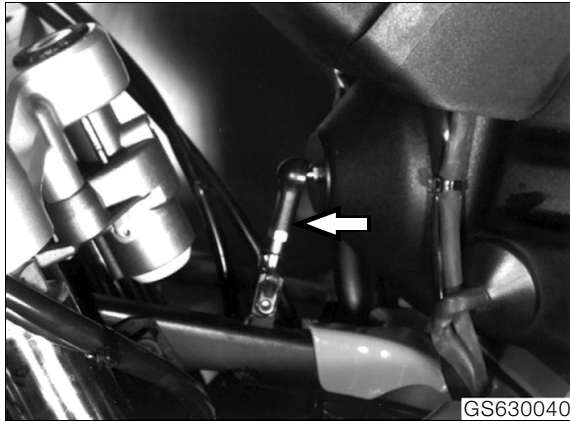

- Unscrew locknut on adjusting linkage (arrow).
- Correct vertical beam throw with adjusting linkage.

### Adjustment distance

..... -25 cm (9.85 in) at a distance of 10 m (32.81 ft)

- Tighten locknut firmly.

## [GS] Removing and installing front flashing turn indicator



### Caution:

Switch off ignition.  
Disconnect ground (earth) lead from battery.  
Insulate ground (earth) lead.

- Procedure: same as for removing headlight.
- Remove headlight holder
- Remove indicator lenses, pull cable connector off reflector and pull cable through indicator holder.



### Caution:

Do not touch inner surface of reflector or bulbs with bare hands.

- Remove turn indicator holder.
- Remove indicators.
- Install in the reverse order of work.

## [R] Removing and installing headlight



### Caution:

Switch off ignition.  
Disconnect ground (earth) lead from battery.  
Insulate ground (earth) lead.



### Caution:

Do not touch inner surface of reflector or bulbs with bare hands.

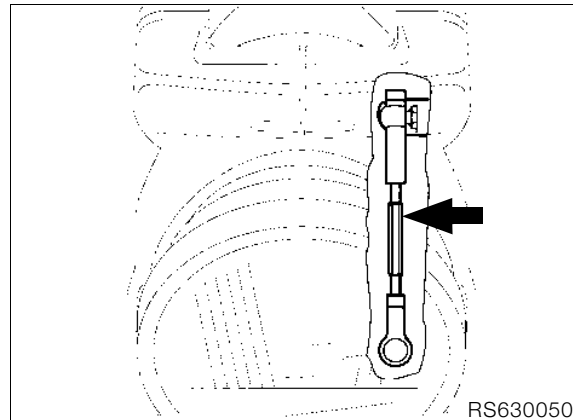

## Adjusting headlight

- Beam throw can be adjusted within the limited rapid resetting range by tilting the headlight upwards or downwards.
- Correct beam throw with the adjusting linkage (arrow).



### Note:

Wrench size = 6 mm (0.24 in)

### Adjustment distance:

..... -25 cm (9.85 in) at a distance of 10 m (32.81 ft)