

5. Rear Brake Pad

A: REMOVAL

- 1) Set the vehicle on a lift.
- 2) Loosen the wheel nuts.
- 3) Jack-up the vehicle, and then remove the rear wheel.
- 4) Remove the lower caliper bolt.

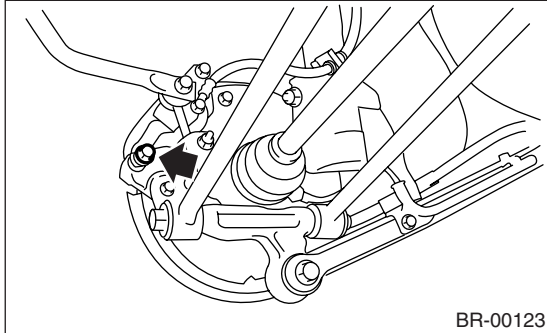

- 5) Raise the caliper body upward and support it.

NOTE:

Do not disconnect the brake hose from caliper body.

- 6) Remove the pad.

NOTE:

If the brake pad is difficult to remove, use the same procedure as for front disc brake pad.

<Ref. to BR-15, REMOVAL, Front Brake Pad.>

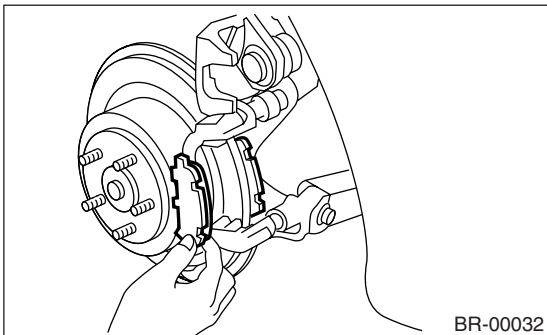

B: INSTALLATION

- 1) Apply a thin coat of Molykote AS880N (Part No. K0777YA010) to the frictional portion between pad and pad clip.
- 2) Install the pad on support.
- 3) Install the caliper body on support.

Tightening torque:

37 N·m (3.8 kgf·m, 27.5 ft-lb)

NOTE:

If it is difficult to push the piston during pad replacement, loosen air bleeder to facilitate work.

C: INSPECTION

Check pad thickness A.

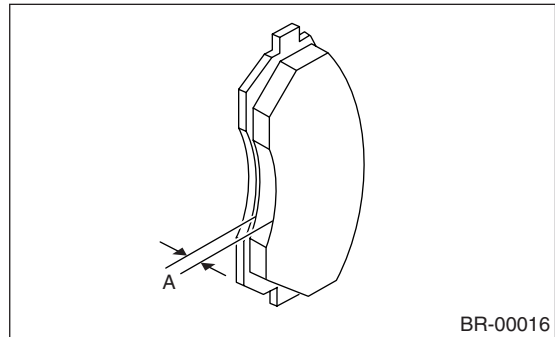

Pad thickness	Standard value	9 mm (0.354 in)
	Wear limit	1.5 mm (0.059 in)

NOTE:

- Always replace the pads for both right and left wheels at the same time.
- Also replace the pad clips if they are twisted or worn.
- A wear indicator is provided on the inner disc brake pad. If the pad wears down to such an extent that the end of wear indicator contacts disc rotor, a squeaking sound is produced as the wheel rotates. If this sound is heard, replace the pad.
- Replace the pad if there is oil or grease on it.