

6. Rear Drive Shaft

A: REMOVAL

- 1) Disconnect the ground cable from battery.
- 2) Lift-up the vehicle, and remove the rear wheel.
- 3) Unlock the axle nut.

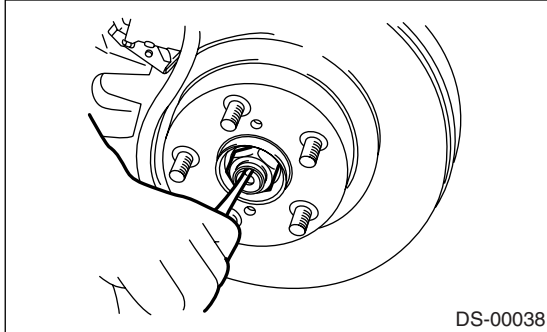

- 4) Remove the axle nut using a socket wrench with brake pedal depressed.

CAUTION:

Remove the axle nut with vehicle weight not applied on axle. Failure to follow this rule may damage the wheel bearings.

- 5) Disconnect the stabilizer link.

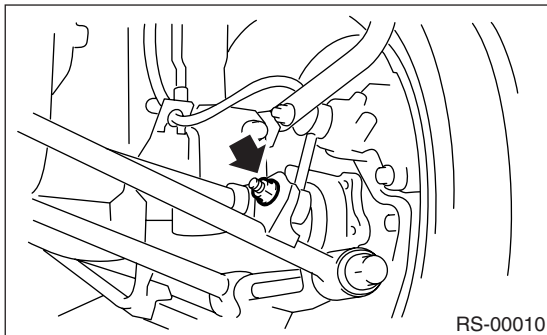

- 6) Remove the bolt which secures trailing link to housing.

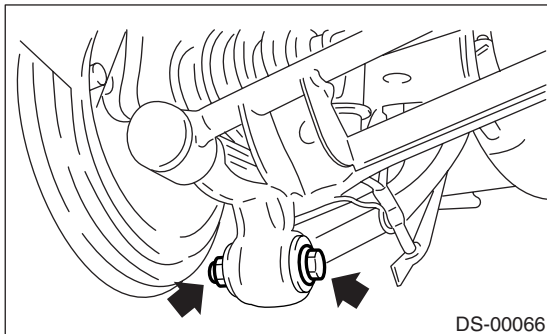

- 7) Remove the bolts which secure front lateral link and rear lateral link to housing.

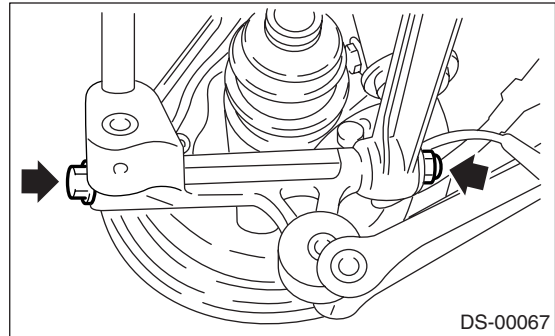

- 8) Remove the rear ABS wheel speed sensor from back plate.

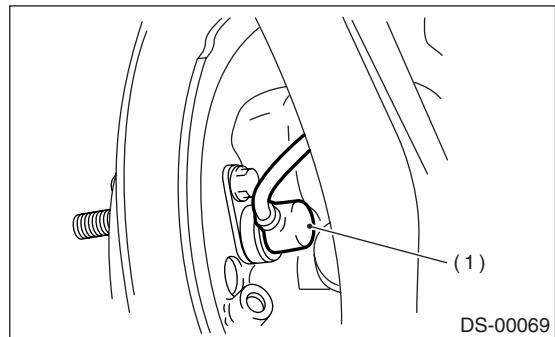

(1) ABS wheel speed sensor

- 9) Remove the rear drive shaft from rear axle. If it is hard to remove, remove the brake disk rotor using the ST1 and ST2.

- | | | |
|-----|-----------|-------------------------|
| ST1 | 926470000 | AXLE SHAFT PULLER |
| ST2 | 927140000 | AXLE SHAFT PULLER PLATE |

CAUTION:

- Do not hammer the drive shaft when removing.
- Do not damage the oil seal and tone wheel.

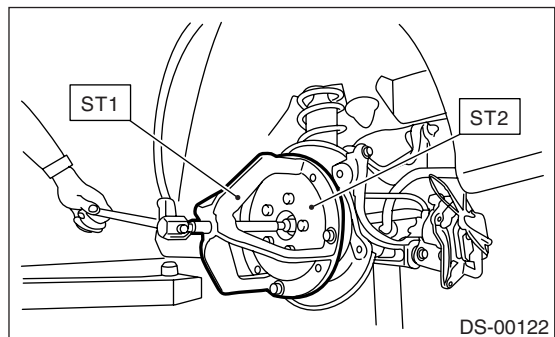

REAR DRIVE SHAFT

DRIVE SHAFT SYSTEM

10) Remove the rear drive shaft from rear differential using ST.

ST 28099PA100 DRIVE SHAFT REMOVER

CAUTION:

Fit ST to the bolt (A) as shown in the figure to avoid damage on the side bearing retainer.

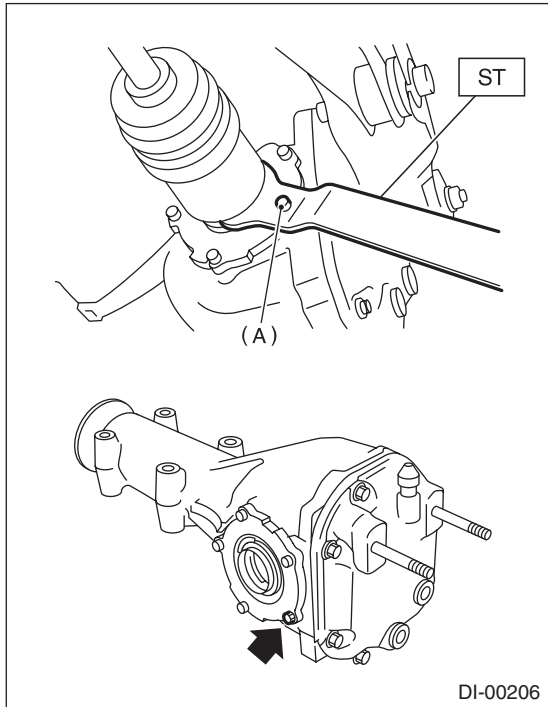

(A) Bolt

B: INSTALLATION

- 1) Insert the rear drive shaft into rear axle.
- 2) Temporarily tighten the axle nut.
- 3) Using ST, protect the oil seal and install the rear drive shaft to rear differential.

ST 28099PA090 OIL SEAL PROTECTOR

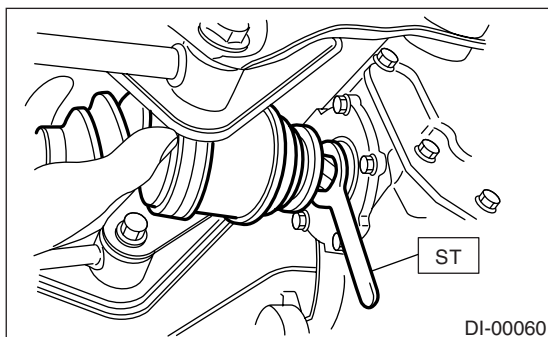

4) Attach the front lateral link and rear lateral link to housing using a new self-locking nuts.

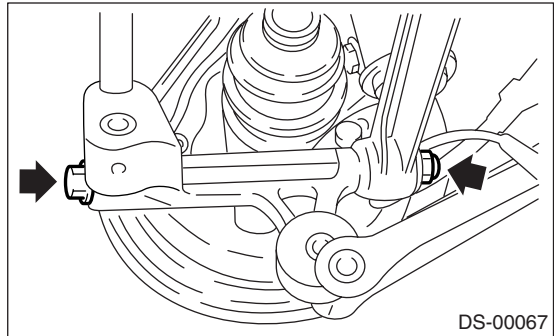

5) Attach the trailing link to housing using a new self-locking nut.

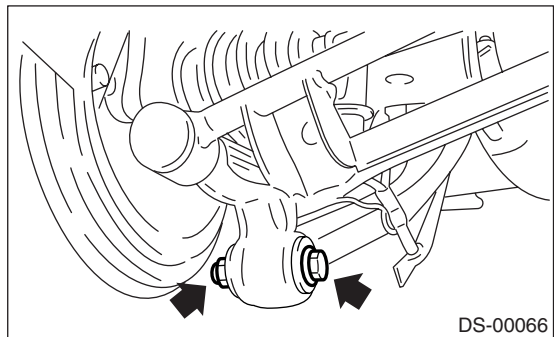

6) Install the stabilizer link.

Tightening torque:

45 N·m (4.6 kgf-m, 33 ft-lb)

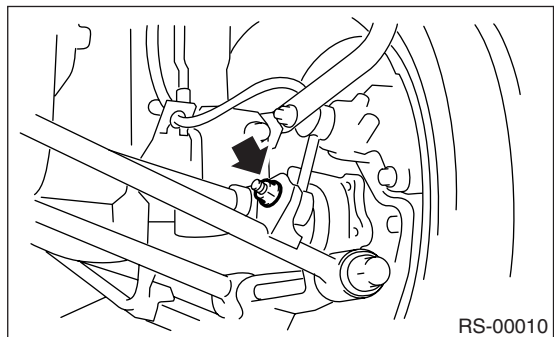

7) Install the ABS wheel speed sensor.

Tightening torque:

32 N·m (3.3 kgf·m, 24 ft·lb)

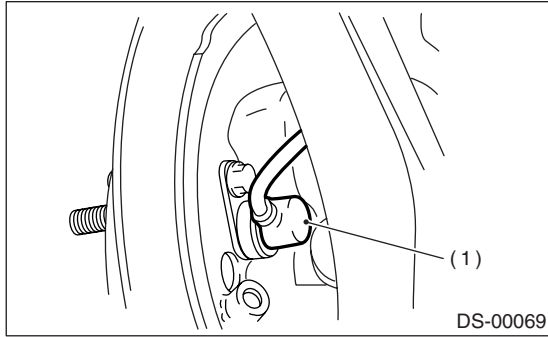

(A) ABS vehicle speed sensor

8) Using the ST1 and ST2, pull the rear drive shaft into place.

ST1 922431000 AXLE SHAFT INSTALLER
ST2 927390000 ADAPTER

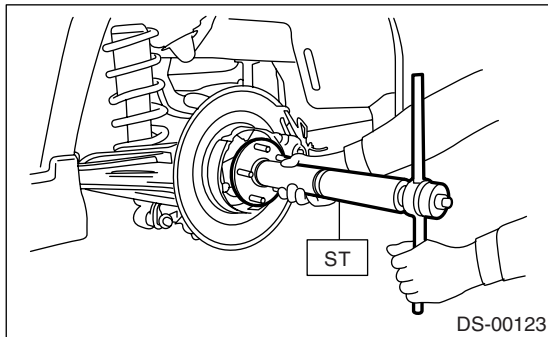

9) Tighten a new axle nut to the specified torque with brake pedal depressed.

Tightening torque:

186 N·m (19 kgf·m, 137 ft·lb)

CAUTION:

Be sure to tighten the axle nut to specified torque. Do not overtighten it as this may damage wheel bearing.

10) Lock the axle nut.

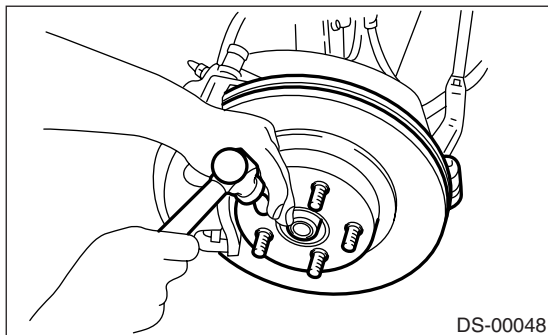

11) Install the wheel.

Tightening torque:

88 N·m (9.0 kgf·m, 65 ft·lb)

12) Make the tires contact the ground fully.

CAUTION:

Make the tires contact the ground fully and the vehicle be in curb weight whenever carrying out the tightening of bush portions.

13) Tighten the installation bolt of rear housing assembly and lateral link assembly.

Tightening torque:

140 N·m (14.3 kgf·m, 103 ft·lb)

14) Tighten the installation bolt of rear housing assembly and trailing link assembly.

Tightening torque:

90 N·m (9.2 kgf·m, 66 ft·lb)

C: DISASSEMBLY

1) Straighten the bent claw of larger end of DOJ boot.

2) Loosen the band by means of screwdriver or pliers with care of not damaging boot.

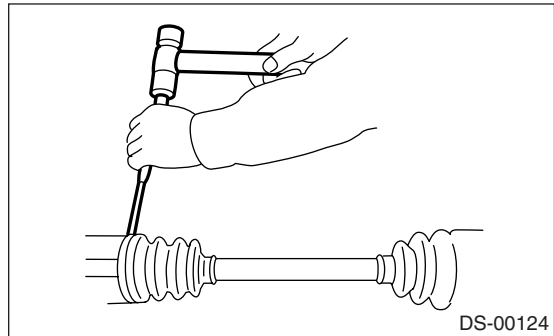

3) Remove the boot band on the small end of DOJ boot in the same manner.

4) Remove the larger end of DOJ boot from DOJ outer race.

5) Pry and remove the round circlip located at neck of DOJ outer race with a screwdriver.

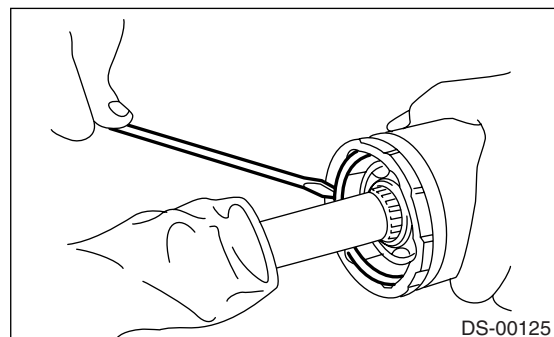

6) Take out the DOJ outer race from shaft assembly.

REAR DRIVE SHAFT

DRIVE SHAFT SYSTEM

7) Wipe off the grease, and then take out the balls.

CAUTION:

- The grease is a special grease (grease for constant velocity joint). Do not confuse with other greases.
- Disassemble with exercising care not to lose balls (6 pcs).

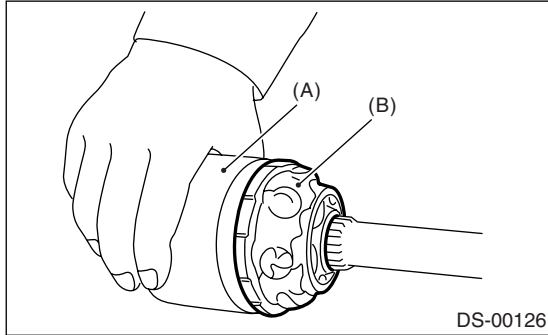

- (A) Outer race
(B) Grease

8) To remove the cage from inner race, turn the cage by a half pitch to the track groove of inner race and shift the cage.

9) Remove the snap ring, which fixes inner race to shaft, by using pliers.

10) Take out the DOJ inner race.

11) Take off the DOJ cage from shaft and remove DOJ boot.

12) Wrap the shaft splines with vinyl tape.

13) Remove the BJ boot in same procedure as DOJ boot.

NOTE:

Thus, disassembly of axle is completed, but the BJ is unable to be disassembled.

D: ASSEMBLY

NOTE:

Use specified grease.

BJ side:

Molylex No. 2 (Part No. 723223010)

DOJ side:

VU-3A702 (Yellow) (Part No. 23223GA050)

- 1) Install the BJ boot in specified position, and fill it with 60 to 70 g (2.12 to 2.47 oz) of specified grease.
- 2) Place the DOJ boot at the center of shaft.
- 3) Wrap the shaft splines with vinyl tape.

4) Insert the DOJ cage onto shaft.

CAUTION:

Insert the cage with cut-out portion facing the shaft end, since the cage has an orientation.

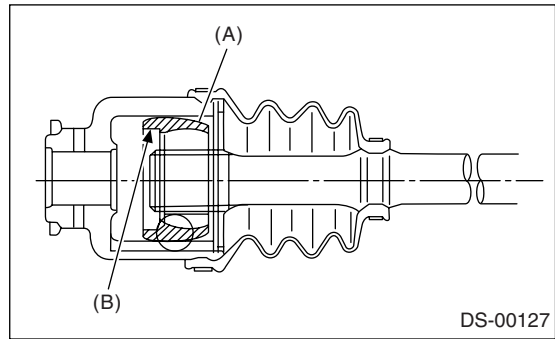

- (A) Cage
(B) Cut-out portion

5) Install the DOJ inner race on shaft and fit snap ring with pliers.

CAUTION:

Confirm that the snap ring is completely fitted in shaft groove.

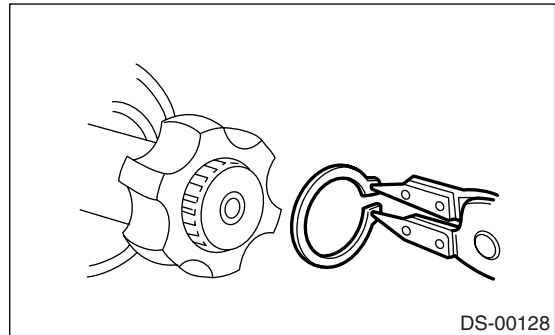

6) Install the cage, which was previously fitted, to inner race fixed upon shaft.

NOTE:

Fit the cage with protruded part aligned with the track on inner race, and then turn by a half pitch.

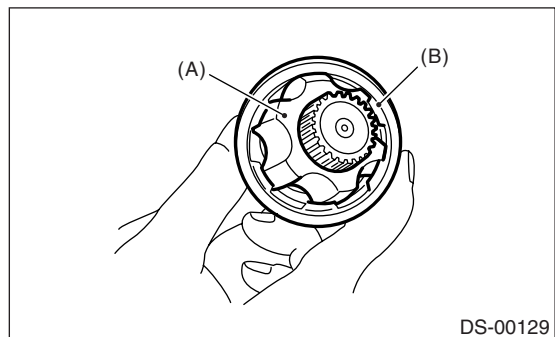

- (A) Inner race
(B) Cage

- 7) Fill 80 to 90 g (2.82 to 3.17 oz) of specified grease into the interior of DOJ outer race.
- 8) Apply a coat of specified grease to the cage pocket and six balls.
- 9) Insert six balls into the cage pocket.
- 10) Align the outer race track and ball positions and place in the part where shaft, inner race, cage and balls are previously installed, and then fit outer race.

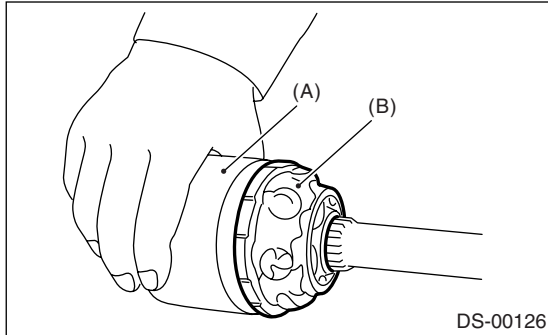

- (A) Outer race
(B) Grease

- 11) Install the circlip in the groove on DOJ outer race.

CAUTION:

- Assure that the balls, cage and inner race are completely fitted in the outer race of DOJ.
- Exercise care not to place the matched position of circlip in the ball groove of outer race.
- Pull the shaft lightly and assure that the circlip is completely fitted in the groove.

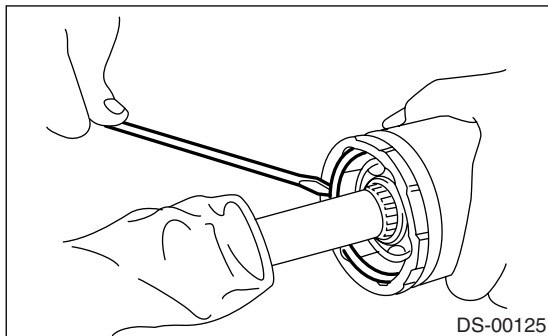

- 12) Apply an even coat of the specified grease [20 to 30 g (0.71 to 1.06 oz)] to the entire inner surface of boot. Also apply grease to shaft.
- 13) Install the DOJ boot taking care not to twist it.

NOTE:

- The inside of the larger end of DOJ boot and boot groove shall be cleaned so as to be free from grease and other substances.
- When installing the DOJ boot, position the outer race of DOJ at center of its travel.

- 14) Put a new band through the clip and wind twice in alignment with band groove of boot.
- 15) Pinch the end of band with pliers. Hold the clip and tighten securely.

CAUTION:

When tightening the boot, exercise care so that air within the boot is appropriate.

- 16) Tighten the band by using ST.
ST 925091000 BAND TIGHTENING TOOL

CAUTION:

Tighten the band until it cannot be moved by hand.

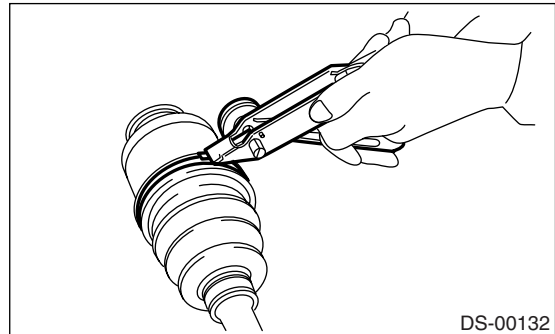

- 17) Tap on the clip with the punch provided at the end of ST.

- ST 925091000 BAND TIGHTENING TOOL

CAUTION:

Tap to an extent that the boot underneath is not damaged.

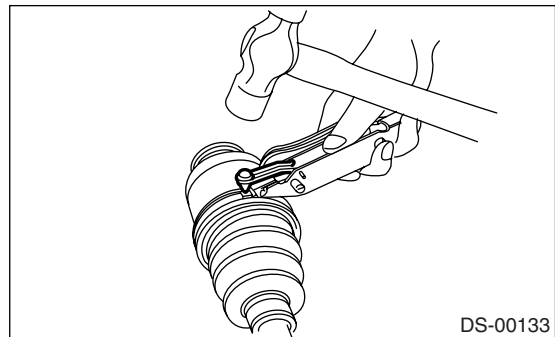

- 18) Cut off the band with an allowance of about 10 mm (0.39 in) left from the clip and bend this allowance over the clip.

CAUTION:

Be careful so that the end of the band is in close contact with clip.

- 19) Fix up the boot on BJ in the same manner.
- 20) Extend and retract repeatedly the DOJ to provide equal grease coating.

E: INSPECTION

Check the removed parts for damage, wear, corrosion etc. If faulty, repair or replace.

1) DOJ (Double Offset Joint)

Check seizure, corrosion, damage, wear and excessive play.

2) Shaft

Check excessive bending, twisting, damage and wear.

3) BJ (Bell Joint)

Check seizure, corrosion, damage and excessive play.

4) Boot

Check for wear, warping, breakage or scratches.

5) Grease

Check for discoloration or fluidity.