

# **Triumph Tiger 800 and Tiger 800XC (Including ABS models) Motorcycle Service Manual**

**Part Number 3856760, issue 1, 12.2010**

This document is protected by copyright and may not, in whole or part be stored in a retrieval system, or transmitted in any form or by any means, copied, photocopied, translated or reduced to any machine-readable form without prior consent in writing from Triumph Motorcycles Limited.

No liability can be accepted for any inaccuracies or omissions in this publication, although every possible care has been taken to make it as complete and accurate as possible.

Triumph Motorcycles Limited reserves the right to make changes and alter specifications without prior notice and without incurring an obligation to make such changes to products manufactured previously. See your authorised Triumph dealer for the latest information on product improvements incorporated after this publication.

All information contained in this publication is based on the latest product information available at the time of publication. Illustrations in this publication are intended for reference use only and may not depict actual model component parts.

© Triumph Motorcycles Ltd. 2010



---

## Table of Contents

<b>Introduction</b>	
<b>General Information</b>	<b>1</b>
<b>Scheduled Maintenance</b>	<b>2</b>
<b>Cylinder Head</b>	<b>3</b>
<b>Clutch</b>	<b>4</b>
<b>Crankshaft, Connecting Rods and Pistons</b>	<b>5</b>
<b>Balancer</b>	<b>6</b>
<b>Transmission</b>	<b>7</b>
<b>Lubrication</b>	<b>8</b>
<b>Engine Removal/Refit</b>	<b>9</b>
<b>Fuel System/Engine Management</b>	<b>10</b>
<b>Cooling</b>	<b>11</b>
<b>Rear Suspension</b>	<b>12</b>
<b>Front Suspension</b>	<b>13</b>
<b>Brakes</b>	<b>14</b>
<b>Wheels/Tyres</b>	<b>15</b>
<b>Frame and Bodywork</b>	<b>16</b>
<b>Electrical</b>	<b>17</b>

---

This page intentionally left blank

# Introduction

## Table of Contents

How to use this manual .....	.vi
Warnings, Cautions and Notes .....	.vi
Tampering with Noise Control System Prohibited .....	.vii
References .....	.vii
Dimensions .....	.vii
Repairs and Replacements.....	.vii
Force.....	.vii
Edges .....	.vii
Tightening procedure.....	.vii

# Introduction

---

This manual is designed primarily for use by trained technicians in a properly equipped workshop. However, it contains enough detail and basic information to make it useful to the owner who desires to perform his own basic maintenance and repair work. The work can only be carried out if the owner has the necessary hand and special service tools to complete the job.

A basic knowledge of mechanics, including the proper use of tools and workshop procedures is necessary in order to carry out maintenance and repair work satisfactorily. Whenever the owner has insufficient experience or doubts his ability to do the work, an authorised Triumph dealer must undertake all adjustments, maintenance, and repair work.

In order to perform the work efficiently and to avoid costly mistakes, read the text and thoroughly familiarise yourself with procedures before starting work.

All work should be performed with great care and in a clean working area with adequate lighting.

Always use the correct special service tools or equipment specified. Under no circumstances use makeshift tools or equipment since the use of substitutes may adversely affect safe operation.

Where accurate measurements are required, they can only be made using calibrated, precision instruments.

For the duration of the warranty period, an authorised Triumph dealer must perform all repairs and scheduled maintenance.

To maximise the life of your Motorcycle:

- **Accurately follow the maintenance requirements of the periodic maintenance chart in the service manual.**
- **Do not allow problems to develop. Investigate unusual noises and changes in the riding characteristics of the motorcycle. Rectify all problems as soon as possible (immediately if safety related).**
- **Use only genuine Triumph parts as listed in the parts catalogue/parts microfiche.**
- **Follow the procedures in this manual carefully and completely. Do not take short cuts.**
- **Keep complete records of all maintenance and repairs with dates and any new parts installed.**
- **Use only approved lubricants, as specified in the owner's handbook, in the maintenance of the motorcycle.**

## How to use this manual

To assist in the use of this manual, the section title is given at the top of each page.

Each major section starts with a contents page, listing the information contained in the section.

The individual steps comprising repair operations are to be followed in the sequence in which they appear.

Adjustment and repair operations include reference to service tool numbers and the associated illustration depicts the tool.

Where usage is not obvious, the tool is shown in use.

Adjustment and repair operations also include reference to wear limits, relevant data, torque figures, specialist information and useful assembly details.

## Warnings, Cautions and Notes

Particularly important information is presented in the following form:

 <b>Warning</b>
This warning symbol identifies special instructions or procedures which, if not correctly followed, could result in personal injury, or loss of life.

 <b>Caution</b>
This caution symbol identifies special instructions or procedures which, if not strictly observed, could result in damage to or destruction of equipment.

### Note:

- **This note symbol indicates points of particular interest for more efficient and convenient operation.**

## Tampering with Noise Control System Prohibited

Owners are warned that the law may prohibit:

- a) The removal or rendering inoperative by any person other than for purposes of maintenance, repair or replacement, of any device or element of design incorporated into any new vehicle for the purpose of noise control prior to its sale or delivery to the ultimate purchaser or while it is in use; and
- b) the use of the vehicle after such device or element of design has been removed or rendered inoperative by any person.

## References

References to the left-hand or right-hand side given in this manual are made when viewing the motorcycle from the rear.

Operations covered in this manual do not always include reference to testing the motorcycle after repair. It is essential that work is inspected and tested after completion and if necessary a road test of the motorcycle is carried out particularly where safety related items are concerned.

## Dimensions

The dimensions quoted are to design engineering specification with service limits where applicable.

During the period of running-in from new, certain adjustments may vary from the specification figures given in this manual. These will be reset by the dealer at the 500 mile/800 km service, and thereafter should be maintained at the figures specified in this manual.

## Repairs and Replacements

Before removal and disassembly, thoroughly clean the motorcycle. Any dirt entering the engine or other parts will work as an abrasive and shorten the life of the motorcycle. Particular attention should be paid when installing a new part, that any dust or metal filings are cleared from the immediate area.

## Force

Common sense should dictate how much force is necessary in assembly and disassembly. If a part seems especially difficult to remove or install, stop and examine what may be causing the problem. Never lever a component as this will cause damage both to the component itself and to the surface being levered against.

Whenever tapping to aid removal of an item is necessary, tap lightly using a hide or plastic faced mallet.

## Edges

Watch for sharp edges, especially during engine disassembly and assembly. Protect the hands with industrial quality gloves.

When replacement parts are required, it is essential that only genuine Triumph parts are used.

Safety features and corrosion prevention treatments embodied in the motorcycle may be impaired if other than genuine Triumph parts are fitted. In certain territories, legislation prohibits the fitting of parts not to the manufacturer's specification.

## Tightening procedure

Generally, when installing a part with several bolts, nuts or screws, they should all be started in their holes and tightened to a snug fit, evenly and in a cross pattern. This is to avoid distortion of the part and/or causing gas or oil leakage. Conversely, bolts, nuts, or screws, should all be loosened (in sequence if specified) by about a quarter of a turn and then removed.

Where there is a tightening sequence specified in this Service Manual, the bolts, nuts, or screws must be tightened in the order and by the method indicated.

Torque wrench setting figures given in this Manual must be observed. The torque tools used must be of accurate calibration.

Locking devices, where specified, must be fitted. If the efficiency of a locking device is impaired during removal it must be renewed. This applies particularly to micro-encapsulated fixings which must always be replaced if disturbed. Where necessary, the text in this manual will indicate where such a fixing is used.

This page intentionally left blank



# 1 General Information

## Table of Contents

Ignition System Safety Precautions .....	1.4
Dangerous Substances .....	1.4
Third Party Products .....	1.4
Fluoroelastomers .....	1.4
Oils .....	1.4
Health Protection Precautions .....	1.5
Environmental Protection Precautions .....	1.5
Brakes .....	1.5
Safety Instructions .....	1.6
Jacking and Lifting .....	1.6
Precautions against Damage .....	1.6
Coolant .....	1.6
Cleaning Components .....	1.7
Lubrication .....	1.7
Joints and Joint Faces .....	1.7
Gaskets, O-rings .....	1.7
Liquid Gasket, Non-permanent Locking Agent .....	1.7
Screw Threads .....	1.7
Locking Devices .....	1.8
Fitting a Split Pin .....	1.8
Circlips, Retaining Rings .....	1.8
Self Locking Nuts .....	1.8
Encapsulated Bolts .....	1.8
Oil and Grease Seals .....	1.8
Press .....	1.8
Ball Bearings .....	1.8
Chassis Bearing Lubrication .....	1.8
Metal bushes .....	1.10
Fuel Handling Precautions .....	1.10
General .....	1.10
Petrol - Gasoline .....	1.10
Fuel Tank Removal .....	1.11
Chassis Repairs .....	1.11
Electrical Precautions .....	1.12

# General Information

---

Battery Disconnecting .....	1.12
Disciplines .....	1.12
Electrical Wires .....	1.13
Electrical Testing .....	1.13
Ohm's Law .....	1.13
Basic Electrical Circuits .....	1.13
Circuit Diagrams .....	1.14
Glossary of Circuit Diagram Symbols .....	1.14
Tracing Circuits .....	1.16
To Check Continuity: .....	1.16
To Measure Voltage: .....	1.17
Splices .....	1.17
CAN (Controller Area Networking) .....	1.18
Alternator/Charging System .....	1.19
Diagnosis - Charging Circuit .....	1.19
Starting Circuit .....	1.20
General Fault Finding - Starter Motor and Relay .....	1.20
Diagnosis - Starter Circuit .....	1.21
Inspection .....	1.22
Replacement Parts .....	1.22
Service Data .....	1.22
Specification .....	1.22
Service Tools and Garage Equipment .....	1.23
Full Specification .....	1.28
Engine .....	1.28
Cylinder Head & Valves .....	1.29
Cylinder Head & Valves (continued) .....	1.30
Camshafts .....	1.30
Clutch/Primary Drive .....	1.31
Pistons .....	1.31
Connecting Rods .....	1.31
Crankshaft .....	1.32
Transmission .....	1.32
Final Drive .....	1.32
Lubrication .....	1.33
Ignition System .....	1.33
Fuel System .....	1.33
Coolant System .....	1.34
Suspension .....	1.34
Fuel Injection System .....	1.35
Emissions Controls .....	1.35
Brakes .....	1.35
Brakes (continued) .....	1.36
Wheels and Tyres .....	1.36
Frame .....	1.37
Electrical Equipment .....	1.37

Torque Wrench Settings .....	1.38
Cylinder Head Area .....	1.38
Clutch .....	1.38
Crankshaft, Crankcase and Sprag .....	1.39
Engine Covers .....	1.39
Transmission .....	1.39
Lubrication System .....	1.40
Final Drive .....	1.40
Cooling System .....	1.41
Fuel System, Exhaust System and Airbox .....	1.42
Rear Suspension .....	1.43
Front Suspension .....	1.43
Wheels .....	1.43
Front Brakes .....	1.44
Rear Brakes .....	1.44
ABS System .....	1.45
Frame, Footrests, Control Plates and Engine Mountings .....	1.45
Electrical .....	1.46
Bodywork .....	1.47
Clutch Cable Routing .....	1.48
Throttle Cable Routing .....	1.49
Main Wiring Harness Routing .....	1.50
Front and Rear Brake Hose Routing - Models Without ABS .....	1.51
ABS Hose Routing .....	1.52
Fuel Tank Breather Hose Routing .....	1.53

## General Information

### Ignition System Safety Precautions

#### Warning

The ignition system produces extremely high voltages. Do not touch any part of the ignition system or any cables while the engine is running.

An electric shock caused by contact with the ignition system may lead to illness, injury or death.

#### Warning

Wearers of surgically implanted heart pacemaker devices should not be in close proximity to ignition circuits and or diagnostic equipment.

The ignition system and any diagnostic equipment may interrupt the normal operation of such devices causing illness or death.

### Dangerous Substances

#### Warning

Many liquids and other substances used in motor vehicles are poisonous and should under no circumstances be consumed and should, as far as possible, be kept from contact with the skin. These substances among others include acid, anti-freeze, asbestos, brake fluid, fuel, lubricants, and various adhesives. Always pay close attention to the instructions printed on container labels and obey the instructions contained within. These instructions are included for your safety and well-being.

**NEVER DISREGARD THESE INSTRUCTIONS!**

### Third Party Products

#### Warning

Many propriety products, such as chemicals, solvents and cleaning agents, will cause damage to components if used incorrectly or inappropriately. Always follow the manufacturer's instructions printed on the product container's labels and obey the instructions given. These instructions are included for your safety and well-being.

Damage to the motorcycle components caused by the incorrect or inappropriate use of chemicals, solvents and cleaning agents may reduce the components efficiency, resulting in loss of motorcycle control and an accident.

### Fluoroelastomers

#### Warning

Fluoroelastomer material is used in the manufacture of various seals in Triumph motorcycles.

In fire conditions involving temperatures greater than 315°C this material will decompose and can then be potentially hazardous. Highly toxic and corrosive decomposition products, including hydrogen fluoride, carbonyl fluoride, fluorinated olefins and carbon monoxide can be generated and will be present in fumes from fires.

In the presence of any water or humidity hydrogen fluoride may dissolve to form extremely corrosive liquid hydrofluoric acid.

If such conditions exist, do not touch the material and avoid all skin contact. Skin contact with liquid or decomposition residues can cause painful and penetrating burns leading to permanent, irreversible skin and tissue damage.

### Oils

#### Warning

The engine and bevel box oils may be hot to the touch. Contact with hot oil may cause the skin to be scalded or burned.

#### Warning

Prolonged or repeated contact with engine oil can lead to skin dryness, irritation and dermatitis. In addition used engine oil contains potentially harmful contaminants which can cause cancer. Wear suitable clothing and avoid skin contact.

## Health Protection Precautions

- Avoid prolonged and repeated contact with oils, particularly used engine oils.
- Wear protective clothing, including impervious gloves where practicable.
- Do not put oily rags in pockets.
- Overalls must be cleaned regularly. Discard heavily soiled clothing and oil impregnated footwear.
- First aid treatment should be obtained immediately for open cuts and wounds. Always be aware of who your nearest first-aid-er is and where the medical facilities are kept.
- Use barrier creams, applying before each work period to protect the skin from the effects of oil and grease and to aid removal of the same after completing work.
- Wash with soap and water to ensure all oil is removed (skin cleansers and nail brushes will help). Preparations containing lanolin replace the natural skin oils which have been removed.
- Do not use petrol, kerosene, diesel fuel, gas oil, thinners or solvents for cleaning skin.
- If skin disorders develop, obtain medical advice without delay.
- Where practicable, de-grease components prior to handling.

### Warning

Any risk of eye injury must be avoided. Always wear eye protection when using a hammer, air line, cleaning agent or where there is ANY risk of flying debris or chemical splashing.

## Environmental Protection Precautions

### Caution

Do not pour oil on the ground, down sewers or drains, or into water courses. To prevent pollution of water-courses etc., dispose of used oil sensibly. If in doubt contact your local authority.

Burning of used engine oil in small space heaters or boilers can be recommended only for units of approved design. If in doubt, check with the appropriate local authority and/or manufacturer of the approved appliance.

Dispose of used oil and used filters through authorised waste disposal contractors, to licensed waste disposal sites, or to the waste oil reclamation trade. If in doubt, contact your local authority for advice on disposal facilities.

## Brakes

### Warning

Brake fluid is hygroscopic which means it will absorb moisture from the air. Any absorbed moisture will greatly reduce the boiling point of the brake fluid causing a reduction in braking efficiency.

Replace brake fluid in line with the routine maintenance schedule. A dangerous riding condition could result if this important maintenance item is neglected!

Do not spill brake fluid onto any area of the bodywork as this will damage any painted or plastic surface.

Always use new brake fluid from a sealed container and never use fluid from an unsealed container or from one that has been previously opened.

Do not mix different brands of fluid. Check for fluid leakage around brake fittings, seals and joints.

Check regularly for brake hose damage.

**FAILURE TO OBSERVE ANY OF THE ABOVE WARNINGS MAY REDUCE BRAKING EFFICIENCY LEADING TO AN ACCIDENT.**

### Warning

If there has been an appreciable drop in the level of the fluid in either brake fluid reservoir, consult your authorised Triumph dealer for advice before riding.

If the brake lever or pedal feels soft when it is applied, or if the lever/pedal travel becomes excessive, there may be air in the brake lines or the brake may be defective.

It is dangerous to operate the motorcycle under such conditions and remedial action must be taken by your authorised Triumph dealer before riding the motorcycle.

Failure to take remedial action may reduce braking efficiency leading to an accident.

### Warning

Use only DOT 4 specification brake fluid as listed in the general information section of this manual. The use of brake fluids other than those DOT 4 fluids listed in the general information section may reduce the efficiency of the braking system leading to an accident.

Failure to change the brake fluid at the interval specified in the routine maintenance schedule may reduce braking efficiency resulting in an accident.

### Warning

Never use mineral based grease in any part of the braking system or in any area where contact with the braking system is possible. Mineral based grease will damage the hydraulic seals in the calipers and master cylinders.

Damage caused by contact with mineral based grease may reduce braking efficiency resulting in an accident.

### Warning

Before installation, all internal brake components should be cleaned and lubricated with clean new DOT 4 brake fluid.

Never use solvents, petrol (gasoline), engine oil, or any other petroleum distillate on internal brake components as this will cause deterioration of the hydraulic seals in the calipers and master cylinders.

A dangerous riding condition leading to loss of motorcycle control and an accident could result if this warning is ignored.

## Safety Instructions

### Jacking and Lifting

### Warning

Always ensure that any lifting apparatus has adequate load and safety capacity for the weight to be lifted. Ensure the motorcycle is well supported to prevent any possibility of the machine falling during lifting or jacking, or while repairs and servicing are carried out.

Never rely on a single means of support when working with the motorcycle. Use additional safety supports and straps to prevent toppling.

Do not leave tools, lifting equipment, spilt oil, etc. in a place where they could become a hazard to health. Always work in a clean, tidy area and put all tools away when the work is finished.

### Precautions against Damage

Avoid spilling brake fluid or battery acid on any part of the bodywork. Wash spillages off with water immediately.

Disconnect the battery earth lead before starting work, see ELECTRICAL PRECAUTIONS.

Always use the recommended service tool where specified.

Protect exposed bearing and sealing surfaces, and screw threads from damage.

### Coolant

### Warning

Coolant mixture, which is blended with anti-freeze and corrosion inhibitors contains toxic chemicals which are harmful to the human body. Never swallow anti-freeze, corrosion inhibitors or any of the motorcycle coolant.

### Warning

Do not remove the radiator cap when the engine is hot. When the engine is hot, the coolant inside the radiator is hot and also under pressure. Contact with the pressurised coolant will cause scalds and skin damage.



## Caution

The coolant anti-freeze contains a corrosion inhibitor which helps prevent damage to the metal surfaces inside the cooling system. Without this inhibitor, the coolant would 'attack' the metals and the resulting corrosion would cause blockages in the cooling system leading to engine overheating and damage. Always use the correct anti-freeze as specified in the Owner's Handbook. Never use a methanol based anti-freeze as this does not contain the required corrosion inhibition properties.



## Caution

Distilled water must be used with the anti-freeze (see specification for anti-freeze) in the cooling system. If hard water is used in the system, it causes scale accumulation in the water passages, and considerably reduces the efficiency of the cooling system. Reduced cooling system efficiency may lead to the engine overheating and engine damage.

## Cleaning Components

A high flash-point solvent is recommended to reduce fire hazard.

Always follow container directions regarding the use of any solvent.

Always use the recommended cleaning agent or equivalent.

Do not use degreasing equipment for components containing items which could be damaged by the use of this process. Whenever possible, clean components and the area surrounding them before removal. Always observe scrupulous cleanliness when cleaning dismantled components.

## Lubrication

The majority of engine wear occurs while the engine is warming up and before all the rubbing surfaces have an adequate lubrication film. During assembly, oil or grease (whichever is more suitable) should be applied to any rubbing surface, which has lost its lubrication film. Old grease and dirty oil should be cleaned off. This is because used lubricants will have lost some lubrication qualities and may contain abrasive foreign particles.

Use recommended lubricants. Some oils and greases in particular should be used only in certain applications and may be harmful if used in an application for which they are not intended. This manual makes reference to molybdenum disulphide grease in the assembly of certain engine and chassis parts. Always check manufacturer recommendations before using such special lubricants.

## Joints and Joint Faces

Assemble joints dry unless otherwise specified in this manual.

If gaskets and/or jointing compound is recommended for use, remove all traces of old jointing material prior to re-assembly. Do not use a tool which will damage the joint faces and smooth out any scratches or burrs on the joint faces using an oil stone. Do not allow dirt or jointing material to enter any tapped holes.

## Gaskets, O-rings

Do not re-use a gasket or O-ring once it has been in service. The mating surfaces around the gasket should be free of foreign matter and perfectly smooth to avoid oil or compression leaks.

## Liquid Gasket, Non-permanent Locking Agent

Follow manufacturer's directions for cleaning and preparing surfaces where these compounds will be used. Apply sparingly as excessive amounts of sealer may block engine oil passages and cause serious damage.

Prior to re-assembly, blow through any pipes, channels or crevices with compressed air.



## Warning

To prevent injury, always use eye, face and ear protection when using compressed air. Always wear protective gloves if the compressed air is to be directed in proximity to the skin.

## Screw Threads

Metric threads to ISO standard are used.

Damaged nuts, bolts and screws must always be discarded.

Castellated nuts must not be slackened back to accept a split-pin, except in those recommended cases when this forms part of an adjustment.

Do not allow oil or grease to enter blind threaded holes. The hydraulic action on screwing in the bolt or stud could split the housing.

Always tighten a nut or bolt to the recommended torque figure. Damaged or corroded threads can affect the torque reading.

Unless specified, threaded fixings must always be fitted dry (no lubrication).



## Warning

Never lubricate a thread unless instructed to do so. When a thread of a fixing is lubricated, the thread friction is reduced. When the fixing is tightened, reduced friction will cause overtightening and possible fixing failure. A fixing which fails in service could cause component detachment leading to loss of control and an accident.

### Locking Devices

Always release locking tabs and fit new locking washers, do not re-use locking tabs.

### Fitting a Split Pin

Always fit new split-pins of the correct size for the hole in the bolt or stud. Do not slacken back castle nuts when fitting split pin, except in those recommended cases when this forms part of an adjustment.

Always fit new roll pins of an interference fit in the hole.

### Circlips, Retaining Rings

Replace any circlips and retaining rings that are removed. Removal weakens and deforms circlips causing looseness in the circlip groove. When installing circlips and retaining rings, take care to compress or expand them only enough to install them.

Always use the correct replacement circlip as recommended in the Triumph Parts Catalogue.

### Self Locking Nuts

Self-locking nuts can be re-used, providing resistance can be felt when the locking portion passes over the thread of the bolt or stud.

DO NOT re-use self-locking nuts in critical locations, e.g. suspension components. Always use the correct replacement self-locking nut.

### Encapsulated Bolts

An encapsulated bolt can be identified by a coloured section of thread which is treated with a locking agent.

Unless a specified repair procedure states otherwise, encapsulated bolts cannot be reused and **MUST** be replaced if disturbed or removed.



## Warning

Failure to replace an encapsulated bolt could lead to a dangerous riding condition. Always replace encapsulated bolts.

### Oil and Grease Seals

Replace any oil or grease seals that are removed. Removal will cause damage to an oil seal which, if re-used, would cause an oil leak.

Ensure the surface on which the new seal is to run is free of burrs or scratches. Renew the component if the original sealing surface cannot be completely restored.

Protect the seal from any surface which could cause damage to the seal lips when it is being fitted. Use a protective sleeve or tape to cover the relevant surface and avoid touching the sealing lip.

Lubricate the sealing lips with a recommended lubricant. This will help to prevent damage in initial use. On dual lipped seals, smear the area between the lips with appropriate grease.

When pressing in a seal which has manufacturer's marks, press in with the marks facing out.

Seals must be pressed into place using a suitable driver. Use of improper tools will damage the seal.

### Press

A part installed using a press or driver, such as a wheel bearing, should first be coated with oil or grease on its outer or inner circumference so that it will locate smoothly.

### Ball Bearings

When installing a ball bearing, the bearing race which is an interference fit should be pushed by a suitable driver. This prevents severe stress or damage to the load carrying components. Press a ball bearing until it touches the shoulder in the bore or on the shaft.

Press or drift seals to the depth of its housing, with the sealing lip facing the lubricant to be retained if the housing is shouldered, or flush with the face of the housing where no shoulder is provided.

### Chassis Bearing Lubrication

#### Note:

- **This information relates only to bearing lubrication. For the procedures necessary to replace a bearing, always refer to the relevant section of this service manual.**
- **Bearings installed in engine and transmission applications are not covered by this information. Refer to the lubrication chapter or the relevant engine chapter for additional information.**



## General

For a bearing to be serviceable for its anticipated life span it must be checked, adjusted and lubricated at regular intervals, as specified in the service schedules given in the owner's handbook and this service manual.

A correctly lubricated bearing will have a film of lubrication that separates the moving parts, disperses heat and protects the bearing surfaces from corrosion.

### Note:

- **In all cases, use the lubricant recommended in the service manual.**
- **Grease the bearing, not the cavity where it is located.**
- **A bearing that is not regularly checked and lubricated will have a reduced life span.**

## New Bearings

New bearings are typically protected with an oil preservative to prevent corrosion etc. during storage. This is NOT the lubrication for the bearing but DOES NOT need to be washed off prior to assembly and in-service lubrication.

When lubricating a new bearing with grease the following steps should be taken:

1. Do not clean off the oil preservative.
2. Grease must be forced between the roller elements and the roller cage.
3. Rotate the bearing to ensure that the grease is distributed over the entire circumference of the internal parts.
4. Any excess grease should be smeared on the outside of the rollers.

## Lubrication and Checks While Servicing a Bearing

1. Disassemble parts as necessary to access the bearing. Refer to the relevant service manual.
2. Inspect the old grease covering the bearing, looking for signs of bearing damage, i.e. flakes or specks of metal.
3. Remove the old grease.

4. Check the bearing for smooth operation and visually check for corrosion, dents and flaking in the bearing race, rollers or cage. Replace if necessary. Refer to the relevant service manual.

Below/overleaf several common bearing types and the lubrication procedures for each are identified:

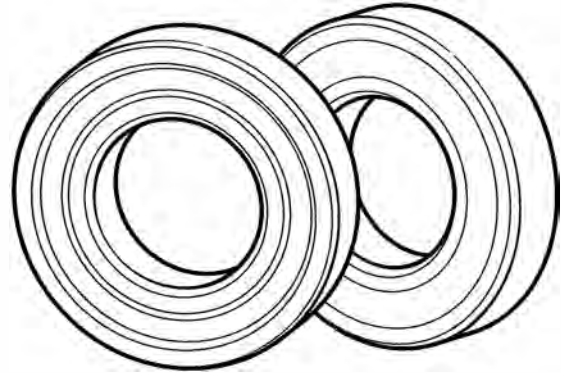

eon

**Sealed bearings (wheel bearings & swinging arm, depending on the model)**

### Note:

- **Sealed bearings can be identified by their integrated seals.**
- **Sealed bearings are lubricated for life by the manufacturer.**
- **Any attempt to change the grease in a sealed bearing will damage the integrated seals. If the seals are damaged dirt and water will ingress and the life of the bearing will be greatly reduced.**

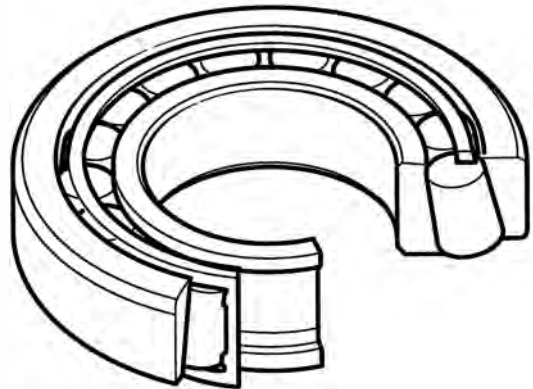

ceon

**Taper bearings (swinging arm & headstock, depending on the model)**

1. Grease must be forced between the inner race and the roller carrier.
2. Rotate the bearing to ensure that the grease is distributed over the entire circumference of the internal parts.

## General Information

- Any excess grease should be smeared on the outside of the rollers.

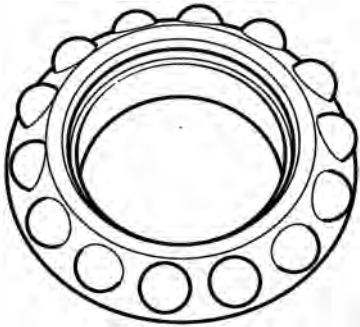

0000

### Angular contact and ball bearings (headstock)

- Grease the bearing races and the ball bearing carrier.
- Rotate the bearing to ensure that the grease is distributed over the entire circumference of the internal parts.

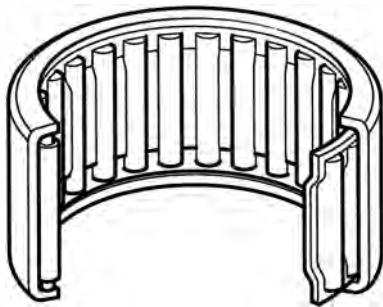

### Needle roller bearings (swinging arm, rear hub, rear suspension linkages, depending on the model)

- Coat the needle rollers with grease.
- Ensure the needle rollers turn so that the grease is distributed over the entire circumference of the internal parts.
- Assemble the parts, adjust and check as necessary.

### Metal bushes

- Disassemble the parts as necessary to access the bush. Refer to the relevant service manual.
- Remove the old grease.
- Apply fresh grease to the metal bush.

## Fuel Handling Precautions

### General

The following information provides basic precautions which must be observed if petrol (gasoline) is to be handled safely. It also outlines other areas of risk which must not be ignored. This information is issued for basic guidance only and, if in doubt, appropriate enquiries should be made of your local Fire Officer.

### Petrol - Gasoline

When petrol (gasoline) evaporates it produces 150 times its own volume in vapour which when diluted with air becomes a readily ignitable mixture. The vapour is heavier than air and will always fall to the lowest level. It can readily be distributed throughout any indoor environment by air currents, consequently, even a small spillage of petrol (gasoline) is potentially very dangerous.



### Warning

Petrol (gasoline) is highly flammable and can be explosive under certain conditions. When opening the fuel tank cap always observe all the following items:

Turn the motorcycle ignition switch OFF.

Do not smoke.

Always have a fire extinguisher containing FOAM, CO<sub>2</sub>, HALON or POWDER close at hand when handling or draining fuel or fuel systems. Fire extinguishers must also be present in areas where fuel is stored.

Always disconnect the vehicle battery, negative (black) lead first, before carrying out dismantling or draining work on a fuel system.

Whenever petrol (gasoline) is being handled, drained, stored or when fuel systems are being dismantled, make sure the area is well ventilated. All potential forms of ignition must be extinguished or removed (this includes any appliance with a pilot light). Any lead-lamps must be flame-proof and kept clear of any fuel spillage.

Warning notices must be posted at a safe distance from the site of the work to warn others that petrol is being openly handled. The notice must instruct the reader of the precautions which must be taken.

Failure to observe any of the above warnings may lead to a fire hazard which could result in personal injury.

### Warning

No one should be permitted to repair components associated with petrol/gasoline without first having specialist training on the fire hazards which may be created by incorrect installation and repair of items associated with petrol/gasoline.

Repairs carried out by untrained personnel could bring about a safety hazard leading to a risk of personal injury.

### Warning

Draining or extraction of petrol/gasoline from a vehicle fuel tank must be carried out in a well ventilated area.

The receptacle used to contain the petrol/ gasoline must be more than adequate for the full amount of fuel to be extracted or drained. The receptacle should be clearly marked with its contents, and placed in a safe storage area which meets the requirements of local authority regulations.

When petrol/gasoline has been extracted or drained from a fuel tank, the precautions governing naked lights and ignition sources should be maintained.

Failure to observe any of the above warnings could bring about a safety hazard leading to a risk of personal injury.

### Fuel Tank Removal

Fuel tanks should have a 'PETROL (GASOLINE) VAPOUR' warning label attached to them as soon as they are removed from the vehicle. In all cases, they must be stored in a secured, marked area.

### Chassis Repairs

### Warning

If the motorcycle is involved in an accident or collision it must be taken to an authorised Triumph dealer for repair or inspection. Any accident can cause damage to the motorcycle, which if not correctly repaired, may cause a second accident which may result in injury or death.

The frame must not be modified as any modification to the frame such as welding or drilling may weaken the frame resulting in an accident.

# General Information

## Electrical Precautions

The following guidelines are intended to ensure the safety of the operator whilst preventing damage to the electrical and electronic components fitted to the motorcycle. Where necessary, specific precautions are detailed in the relevant sections of this manual which should be referred to prior to commencing repair operations.

**Equipment** - Prior to commencing any test procedure on the motorcycle ensure that the relevant test equipment is working correctly and any harness or connectors are in good condition, in particular mains leads and plugs.

### Warning

The ignition system produces extremely high voltages. Do not touch any part of the ignition system or any cables while the engine is running.

An electric shock caused by contact with the ignition system may lead to illness, injury or death.

### Warning

Wearers of surgically implanted heart pacemaker devices should not be in close proximity to ignition circuits and or diagnostic equipment.

The ignition system and any diagnostic equipment may interrupt the normal operation of such devices causing illness or death.

### Warning

The battery contains harmful materials. Always keep children away from the battery whether or not it is fitted in the motorcycle.

Do not jump start the battery, touch the battery cables together or reverse the polarity of the cables as any of these actions may cause a spark which would ignite battery gasses causing a risk of personal injury.

**High Voltage Circuits** - Whenever disconnecting live High Tension (H.T.) circuits always use insulated pliers. Exercise caution when measuring the voltage on the coil terminals while the engine is running, high voltage spikes can occur on these terminals.

**Connectors and Harness** - The engine of a motorcycle is a particularly hostile environment for electrical components and connectors. Always ensure these items are dry and oil free before disconnecting and connecting test equipment. Never force connectors apart either by using tools or by pulling on the wiring itself. Always ensure locking mechanisms are disengaged before removal and note the orientation to enable correct reconnection. Ensure that any protective covers and substances are replaced if disturbed.

Having confirmed a component to be faulty, switch off the ignition and disconnect the battery negative (black) lead first. Remove the component and support the disconnected harness. When replacing the component keep oily hands away from electrical connection areas and push connectors home until any locking mechanism becomes fully engaged.

### **Battery Disconnecting**

Before disconnecting the battery, switch off all electrical equipment.

### Warning

To prevent the risk of a battery exploding and to prevent damage to electrical components ALWAYS disconnect the battery negative (black) lead first. When reconnecting the battery, always connect the positive (red) lead first, then the negative (black) lead. Always disconnect the battery when working on any part of the electrical system.

Failure to observe the above warnings may lead to electrical damage and a fire hazard which could cause personal injury.

Always ensure that battery leads are routed correctly and are not close to any potential chafing points.

### **Disciplines**

Switch off the ignition prior to making any connection or disconnection in the system. An electrical surge can be caused by disconnecting 'live' connections which can damage electronic components.

Ensure hands and work surfaces are clean and free of grease, swarf, etc. as grease collects dirt which can cause tracking or high-resistance contacts.

Prior to commencing any test, and periodically during any test, touch a good earth to discharge body static. This is because some electronic components are vulnerable to static electricity.

## Electrical Wires

All the electrical wires are either single-colour or two-colour and, with only a few exceptions, must be connected to wires of the same colour. On any of the two-colour wires there is a greater amount of one colour and a lesser amount of a second colour. A two-colour wire is identified by first the primary colour and then the secondary colour. For example, a yellow wire with thin red stripes is referred to as a 'yellow/red' wire; it would be a 'red/yellow' wire if the colours were reversed to make red the main colour.

## Electrical Testing

For any electrical system to work, electricity must be able to flow in a complete circuit from the power source (the battery) via the components and back to the battery. No circuit means no electrical flow. Once the power has left the positive side of the battery and run through the component it must then return to the battery on its negative side (this is called earth or ground). To save on wiring, connections and space, the negative side of the battery is connected directly to the frame or engine. Around the frame and engine will be various other ground points to which the wiring coming from components will be connected. In the case of the starter motor it bolts directly to the engine, which is bolted to the frame. Therefore the frame and engine also form part of the earth return path.

## Ohm's Law

The relationship between voltage, current and resistance is defined by Ohm's Law.

- The potential of a battery is measured in Volts (V).
- The flow of current in a circuit (I) is measured in Amperes.
- The power rating of a consumer is measured in Watts (W).
- The resistance (R) of a circuit is measured in Ohms ( $\Omega$ ).

Ohms law, for practical work can be described as -

$$\frac{\text{Voltage}}{\text{Current}} = \text{Resistance}$$

Power is calculated by multiplying Volts x Amps -

$$\text{Watts} = \text{Volts} \times \text{Amps}$$

By transposing either of these formulae, the value of any unit can be calculated if the other two values are known.

For example, if a battery of 12V is connected to a bulb of 60W:

- the current flowing in the circuit can be calculated by using -

$$\frac{W}{V} = I \quad \frac{60}{12} = 5$$

- the bulb resistance can be calculated by using -

$$\frac{V}{I} = R \quad \frac{12}{5} = 2.4$$

To use either of the following triangles, put your finger over the value you want to find. Multiply the remaining values if side-by-side, or divide if one is over the other.



## Basic Electrical Circuits

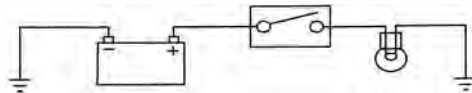

### Basic Circuit Diagram

In the above circuit an electrical reservoir (the battery) is connected via a cable to a terminal on the controlling device (the switch) whose contacts are either open or closed. The other terminal on the switch is connected via a cable to the consumer (the bulb), and the other side of the bulb filament is connected to ground (earth) by another cable. The ground point is usually a part of the frame or engine, to which the battery negative terminal is also connected.

When the switch contacts are open (as shown in the diagram), the circuit is broken and no current flows. When the switch contacts are closed the circuit is made and current flows from the battery positive terminal through the switch contacts and bulb filament to ground. The frame completes the circuit to the battery negative terminal and the bulb illuminates.

Although some circuits on the circuit diagram may at first seem more complicated, it will generally be found that they can be broken down into sections which do not differ greatly from the basic circuit above.

## Circuit Diagrams

Circuit diagrams are created to provide a 'picture' of the electrical system and to identify the route taken by each individual wire through the system, in order to identify which components it feeds and which connectors the wire runs through. Circuit diagrams are an essential tool for fault finding, as it is possible to locate start and finish points for a circuit without having to manually trace the wire through the motorcycle itself. Circuits diagrams may look confusing at first but when they are studied closely they soon become logical.

Due to the complex circuits and the number of individual wires, Triumph uses two types of circuit diagram in its service manuals.

- Within the manual conventional circuit diagrams are used to show the layout of the main circuits of the motorcycle. These are: Engine management/ignition, Lighting, Starting and Charging and Auxiliary and Accessory. In these diagrams no attempt is made to show the components of the system in any particular order or position in relation to the motorcycle.
- At the back of the service manual a full colour layout circuit diagram is used to show the main electrical components in a position similar to the actual position on the motorcycle.

Both of these circuit diagrams use similar symbols to illustrate the various system components and will be accompanied by a key to circuit diagram components and wiring colour codes.

Circuit diagrams also depict the inner workings of a switch cube (I.E. which wire connects to which when a switch is turned from one position to another) so that a test of that switch can be made using the wire terminals in the connector instead of disassembling the switch itself.

## Glossary of Circuit Diagram Symbols

The following is a description of the symbols found in the circuit diagrams used in all Triumph service manuals.

### Connector



This illustration is used to show all multi-plug type electrical connectors on Triumph circuit diagrams. The numbers in the box relate to the terminal numbers of the connector pins. On ECMs with two connectors, the number would be prefixed with the letters 'A' or 'B' to identify each connector. An additional number outside the box will identify the component.

### Diode



An electrical one-way valve. Diodes allow current to flow in one direction but will not allow it to return. The arrow, which forms part of the diode symbol, indicates the direction of current flow.

### Electromagnetic Winding (solenoid)

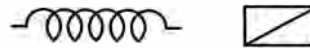

An electromagnetic winding (or solenoid) is used to convert an electrical current into a lateral movement. This can then be used to operate switches (as used in relays) or other components such as fuel injectors or secondary air injection solenoids.

### Fuse

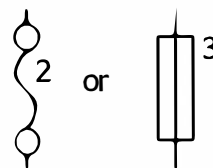

A fuse is a device which protects a circuit in the event of a fault. The fuse will 'blow' should a short circuit occur, protecting that circuit from further damage. The number next to the fuse on the circuit diagram indicates the position of the fuse in the fusebox.

## Ground or Earth Point

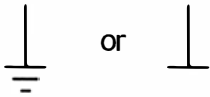

This symbol is used to show ground points. This is the negative connection to either the frame or engine, and is a common cause of intermittent faults due to loose or corroded connections.

## Lamp or Bulb

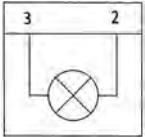

This symbol is used to show all types of light bulbs. The numbers in the box relate to the terminal numbers of the connector pins. An additional number outside the box will identify the component.

## LED (Light Emitting Diode)



Triumph use LEDs for the alarm warning light, instrument illumination and warning lights, gear change lights and rear light/brake lights on various models.

## Motor

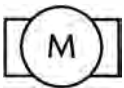

An electric motor. This could be the starter motor or a motor within an actuator, for example within the ABS modulator.

## Relay

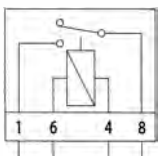

A relay is effectively an electromagnetic switch. To close the relay contacts and complete the circuit, an electromagnet in the relay is energised which causes the relay contacts to close, making the circuit complete.

Relays are used when the electrical current is too great for a mechanical switch, usually when the switching must be done quickly to prevent arcing across the switch contacts. If a mechanical switch were used, the mechanical switch contacts would quickly burn away.

## Resistor



A device placed in a cable to reduce a voltage or restrict the maximum current a device can draw.

## Splice



A hard cable joint where two or more cables are joined in the wiring harness. A potential source of both open and short circuits.

## Switches

Normally Open



or



Normally Closed



or



Change Over

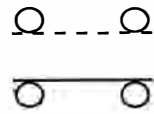

or

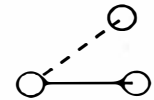

A mechanical device for completing or breaking a circuit. There are three common types of switch: Normally open, normally closed and change-over.

# General Information

## Tracing Circuits

The following is a description of two types of common electrical failures, and some of the methods which may be used to find them.

### Open circuit

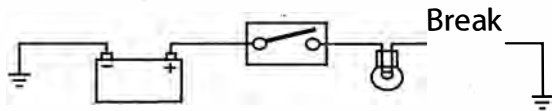

A break in an electrical circuit - current cannot flow. Usually caused by a break in a wire or cable or by a loose connection. Open circuits can often be intermittent, making diagnosis difficult.

### Short circuit

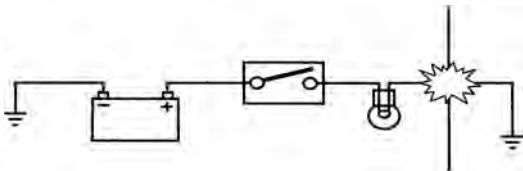

A 'short cut' in an electrical circuit - current by-passes the intended circuit, either to earth or to another, different circuit. Often caused by failure of the cable insulation due to chafing or trapping of the wire. There are two different types of short circuit - short to ground and short to Vbatt.

A short to ground means that the current is going to earth before it reaches the component it is supposed to feed. These are often caused by chafing of the harness to the frame or wires trapped between a bolted component, and will often blow the fuse on that circuit.

A short to Vbatt is a short to battery voltage (12 Volts) and is caused by a live power supply wire contacting an adjacent cable. Note that it is also possible for a 5 Volt sensor reference voltage to short to an adjacent circuit, which can also cause electrical failures and DTCs (Diagnostic Trouble Code) to be stored.

When tracing a wire that is suspect, carefully check the circuit diagram before starting. Remember:

- a wire may diverge at a splice and go off to feed other circuits. If these circuits are working, check for wiring faults from the splice onwards.
- the circuit diagram is not an accurate guide to the actual location of the parts when fitted on the bike. It is a schematic diagram of the circuits.
- particularly where engine management items are concerned, the circuit is only completed by the ECM. If the ECM is not connected, the circuit may register as open.

## To Check Continuity:



### Caution

Ensure the circuit being tested is switched off before measuring continuity. Damage to the Digital Multi Meter (DMM) may result from testing a 'live' circuit with the meter set to resistance ( $\Omega$ ).

In the example below, the ground circuit continuity is being tested from the battery to the frame.

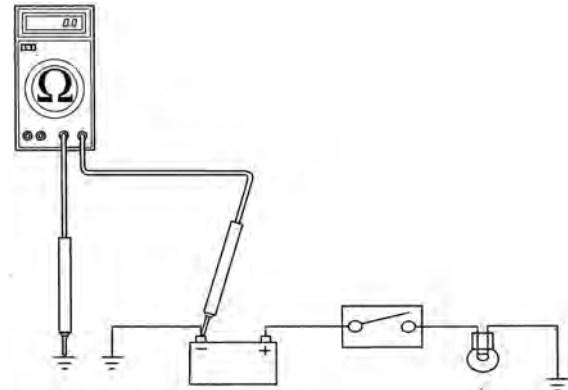

### Continuity (resistance) Check

- Locate each end of the wire.
- Set the Digital Multi Meter (DMM) to resistance check ( $\Omega$ ).
- Probe each end of the wire.
- If there is continuity, the meter will usually beep or register the resistance of the cable.
- A high resistance figure could indicate a dirty or corroded connection.
- If there is a break in the wire, the meter will not beep or register a resistance.
- By probing the wire in various places, the position of a high resistance or break in the wire (open circuit) can be narrowed down until it is found.



## To Measure Voltage:

In the example below, the circuit voltage is being measured at the bulb positive (+) terminal.

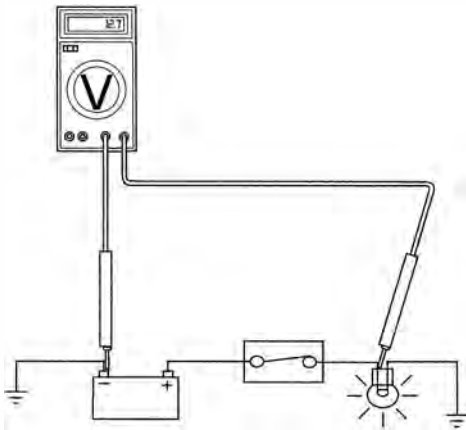

### Voltage Check

- Turn the circuit to be tested 'ON'
- Set the Digital Multi Meter (DMM) to Voltage check (V). Ensure the multi meter is set to dc volts for direct current circuits (most circuits) or ac volts for alternating current circuits (typically alternator output voltage tests).
- Set the range of the DMM to the range best suited to the voltage of the circuit being tested (typically 20 volts for most DMMs). Refer to the DMM manufacturers instructions.
- Connect the black (ground) lead of the DMM to a reliable ground connection (usually the battery or frame ground).
- Locate the positive terminal of the wire or component to be tested.
- connect the red (positive) lead of the DMM to the positive terminal.
- Read the voltage from meter.

## Splices

Splices are probably the most common cause of wiring faults after connectors. Splices are made where two or more wires come together and diverge in different directions, usually to feed a different circuit.

To locate a splice, it is necessary to peel back the insulation and examine the splice for its integrity. The most common fault is where one of the wires at the joint has come adrift usually causing the circuit it feeds or earths to become 'dead'.

## Switches

To check a switch, set the multimeter to resistance/continuity and probe the two pins that form a closed circuit when the switch is pushed. If the switch is working correctly, the resistance should register or the meter will beep.

## Relays

All relay cases have a circuit path engraved on them showing the circuit path across the electromagnet and the switch. Before making any checks, first note the pin designations, current paths, and whether or not there is a diode in either circuit path.

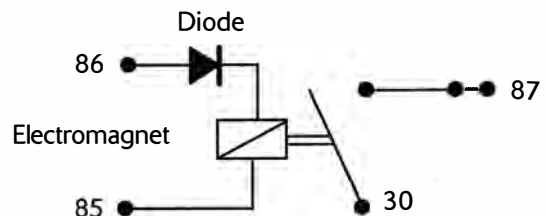

Make continuity checks across the electromagnet first, usually from pin 86 (positive) to pin 85 (negative). If a diode appears in the circuit use the diode check on the multimeter (volts scale) in the direction of current flow. If there is no diode, use the resistance check facility. An open circuit or unusually high resistance value indicates a faulty relay.

To check the switch side, apply a 12 volt supply between pins 86 and 85. With the supply connected the relay should be heard to click and there should be continuity between pins 30 and 87. An open circuit indicates a faulty relay.

# General Information

## CAN (Controller Area Networking)

CAN (sometimes called CANbus) is a protocol for data communication between Electronic Control Modules (ECMs). Each ECM on the network is connected by a single pair of twisted wires (or bus) which are used for the transmission of vehicle sensor data. By using CAN, the overall number of system sensors, and the amount of cabling required to allow ECMs to communicate with each other is greatly reduced.

This saves cost, weight and space, and makes the system more reliable, as the physical number of wires and connections is reduced.

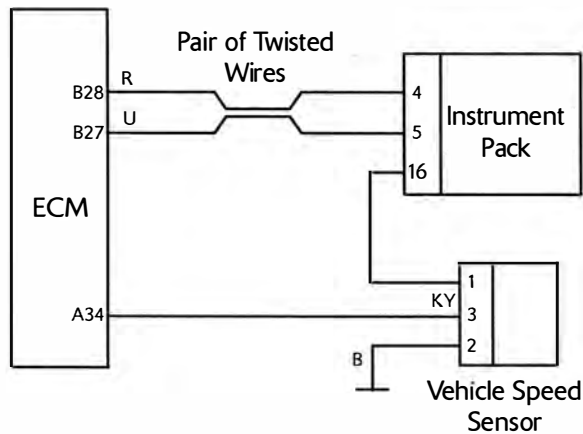

**Extract from the circuit diagram showing CAN connection between ECMs**

CAN works by each ECM sending out 'packets' of information (such as engine speed or fuel consumption information) on to the network bus (note that the network must be free of data before any ECM is allowed to transmit). This data is given a priority according to its importance (for example 'engine speed' may have a higher priority than 'low fuel level'), so that even if two ECMs send data at the same time, high priority information is always sent first. Lower priority data is then resent after the high priority data has been received by all ECMs on the network.

The receiving ECM confirms the data has been received correctly and that the data is valid, and this information is then used by the ECM as necessary. Specific data not required by an ECM will still be received and acknowledged as correct but then disregarded (for example if an ECM does not require 'clutch switch position' information, this data packet would be ignored).

This allows for a very high speed system of communication, which is also very reliable. Should one ECM fail or transmit corrupted or otherwise incorrect messages, none of the other ECMs on the network will be affected, and after a certain time that ECM will be prevented from transmitting further messages until the fault is rectified. This stops the ECM from clogging the network with incorrect data and preventing other messages from getting through. The fault would then be reported by a DTC (Diagnostic Trouble Code).

Triumph currently use CAN for communication between the engine ECM and the instruments.

## Alternator/Charging System

The charging system consists of an alternator and a rectifier/ regulator assembly and the battery. The alternator is made up of two parts, the stator, which is mounted to the crankcase or the engine cover, and the rotor, mounted to the end of the crankshaft. The stator is an assembly of 18 coils, arranged into 3 phases. The rotor is a series of magnets mounted in the engine flywheel, which are arranged so as to be positioned around the outside of the stator coils. As the engine rotates the alternator produces an ac (alternating current) voltage in each of the three phases of the alternator, typically of around 35 to 40 volts ac at 4000-5000 rpm, although this figure varies between models. As the battery requires dc (direct current) voltage for correct charging, this ac voltage must be first rectified to dc current, and then regulated to the correct voltage for the battery of  $14.5 \pm 0.5$  volts. This is done by the rectifier/regulator,

which uses diodes to convert the alternator output to dc volts and limit the resulting output to the correct figure required for optimal battery charging.

If the charging circuit does not operate correctly, the following basic checks must be carried out before further diagnosis is performed:

- Check the battery terminals are clean and tight.
- Check the frame and engine earth connections are clean, tight and free from corrosion.
- Ensure the battery is fully charged and in good condition.
- Check that any fuse in the circuit is not blown and is of the correct rating (See page 17-11).

Rectify any defects as necessary.

## Diagnosis - Charging Circuit

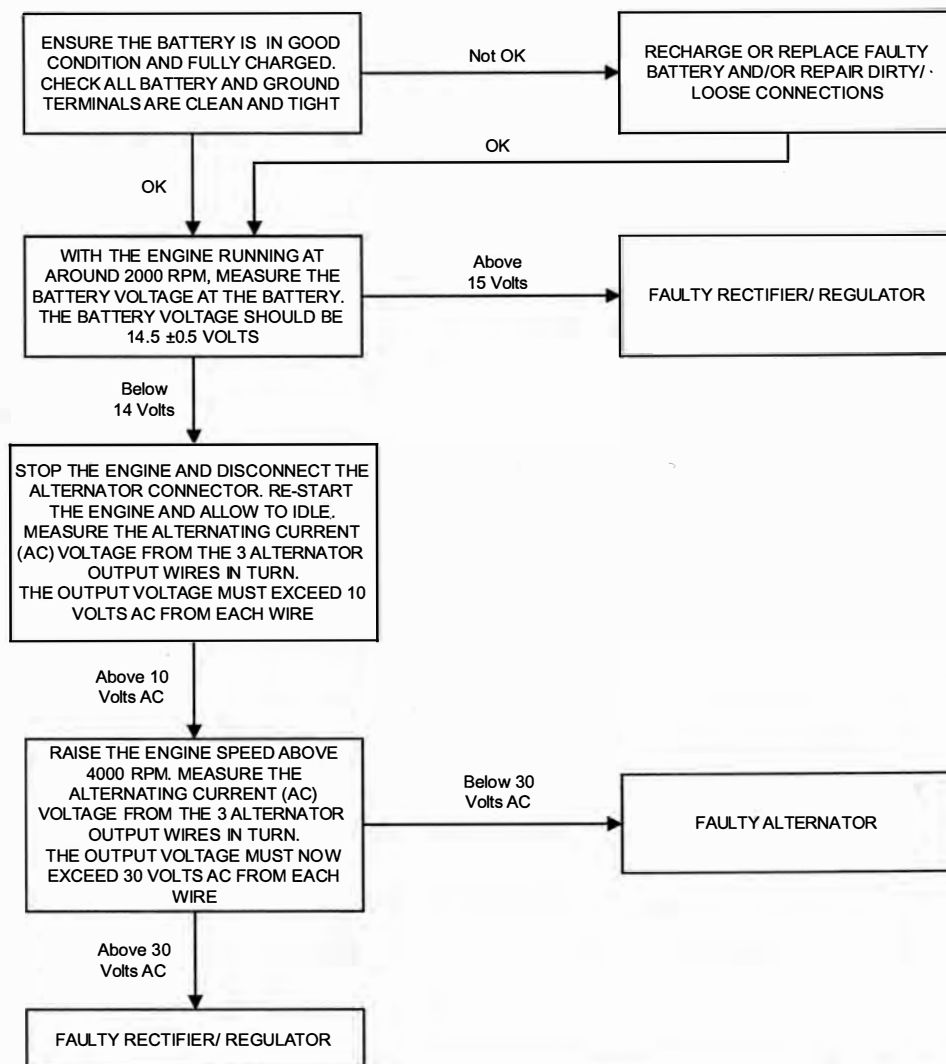

# General Information

## Starting Circuit

All Triumph models are equipped with an electric start system. This system consists of a starter relay, starter motor, starter switch, sidestand switch, engine stop switch, clutch switch and the sprag clutch. The starter motor is connected to the starter relay and the battery by heavy duty cables in order to supply the large currents required by the motor to start the engine. When the starter button is pressed the relay is energised, which then allows current to the starter motor. The starter motor will not operate unless the clutch lever is pulled in. Also, the starter will not operate if the sidestand is down, unless the transmission is in neutral. If the starter motor does not operate, the following basic checks must be carried out before further diagnosis is performed:

- Check the engine stop switch is in the 'RUN' position.
- Check the battery terminals are clean and tight.
- Check the frame and engine earth connections are clean, tight and free from corrosion.
- Ensure the battery is fully charged and in good condition.
- Check that any fuse in the circuit is not blown and is of the correct rating.
- Using the triumph diagnostic tool, check the operation of the neutral switch or gear position sensor (if fitted), sidestand and clutch switches.

### Note:

- **On all new models from Daytona 675 onwards, which use a CAN connection between the instruments and the ECM, the engine will not crank if the instruments are disconnected.**

Rectify any defects as necessary.

## General Fault Finding - Starter Motor and Relay

Symptom	Possible cause(s)
Starter relay does not click, starter motor does not turn	Battery discharged or defective
	Blown main or starter relay fuse
	Defective starter relay wiring or starter switch
	Check that the sidestand, transmission and clutch lever are positioned for engine starting I.E. transmission in neutral, clutch lever pulled in and the sidestand down
	Defective alarm system - ensure any alarm fitted is working correctly
Starter motor turns slowly	Battery discharged or defective
	Loose, corroded or dirty battery connections
	Loose, corroded or dirty starter motor or starter relay connections
	Defective starter motor
	Loose, corroded or dirty battery ground connections
Starter relay clicks but engine does not turn over	Battery discharged or defective
	Crankshaft does not turn due to engine defect
	Defective starter motor
	Starter cable open circuit
	Defective starter relay
Starter motor turns but engine does not turn over	Defective sprag clutch
	Defective idler gear, reduction gear or starter motor

Diagnosis - Starter Circuit

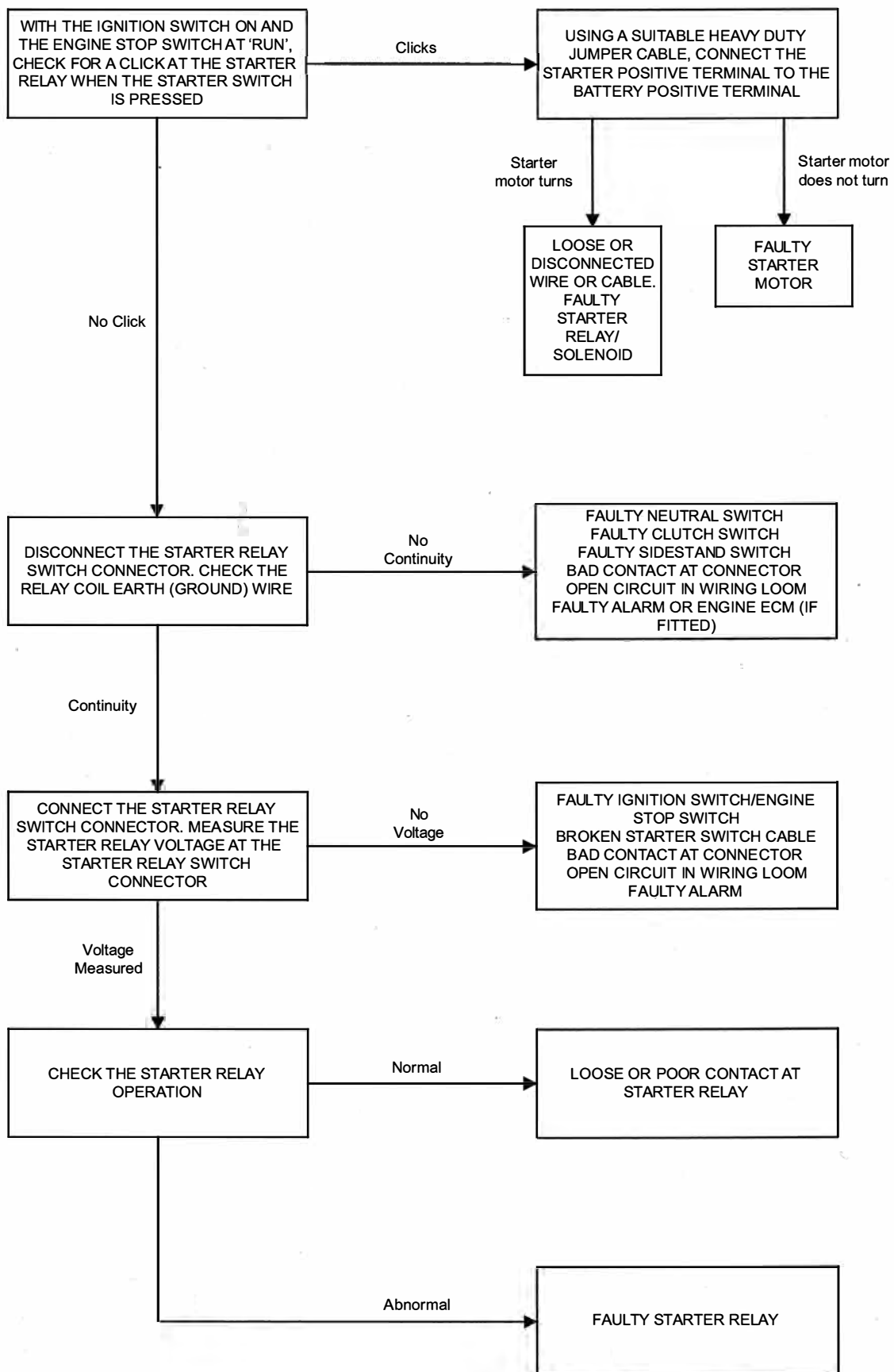

# General Information

---

## Inspection

Disassembled parts should be visually inspected and replaced with new ones if there are any signs of the following:

Abrasions, cracks, hardening, warping, bending, dents, scratches, colour changes, deterioration, seizure or damage of any nature.

## Replacement Parts



### Warning

Only Triumph genuine parts should be used to service, repair or convert Triumph motorcycles. To ensure that Triumph genuine parts are used, always order parts, accessories and conversions from an authorised Triumph dealer. The fitting of non-approved parts, accessories or conversions may adversely affect the handling, stability or other aspects of the motorcycle operation which may result in an accident causing serious injury or death.



### Warning

Always have Triumph genuine parts, accessories and conversions fitted by an authorised Triumph dealer. The fitment of parts, accessories and conversions by a dealer who is not an authorised Triumph dealer may affect the handling, stability or other aspects of the motorcycle operation which may result in an accident causing serious injury or death.



### Warning

Always have Triumph approved parts, accessories and conversions fitted by a trained technician. To ensure that a trained technician is used, have an authorised Triumph dealer fit the parts. The fitment of parts, accessories and conversions by personnel other than a trained technician at an authorised Triumph dealer may affect the handling, stability or other aspects of the motorcycle operation which may result in an accident causing serious injury or death.

## Service Data

The service data listed in this manual gives dimensions and specifications for brand new, original parts. Where it is permissible to allow a part to exceed these figures, then the service limit is given.

The terms of the motorcycle warranty will be invalidated by the fitting of other than genuine Triumph parts.

All genuine Triumph parts have the full backing of the motorcycle warranty. Triumph dealers are obliged to supply only genuine Triumph recommended parts.

## Specification

Triumph are constantly seeking to improve the specification, design and production of their motorcycles and alterations take place accordingly.

While every effort has been made to ensure the accuracy of this Manual, it should not be regarded as an infallible guide to current specifications of any particular motorcycle.

Authorised Triumph dealers are not agents of Triumph and have no authority to bind the manufacturer by any expressed or implied undertaking or representation.

## Service Tools and Garage Equipment

Special service tools have been developed to facilitate removal, dismantling and assembly of certain mechanical components in a practical manner without causing damage. Some operations in this Service Manual cannot be carried out without the aid of the relevant service tools. Where this is the case, the tools required will be described during the procedure.

### Special Service Tools

T3880105 - Angular Torque Gauge

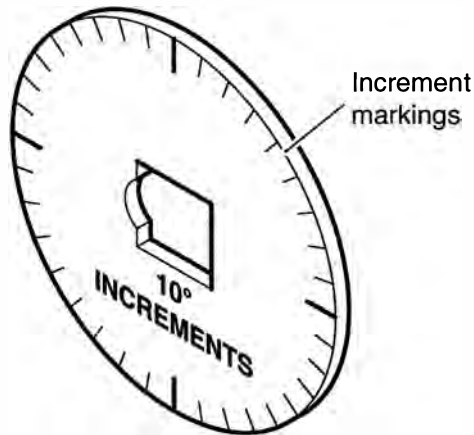

cbxt

T3880315 - Extractor, Cylinder Liner  
(use with adaptor T3880101)

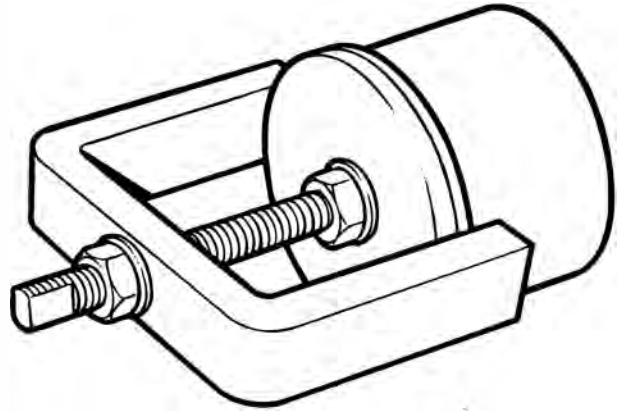

gakh

T3880101 - Extractor, Cylinder Liners

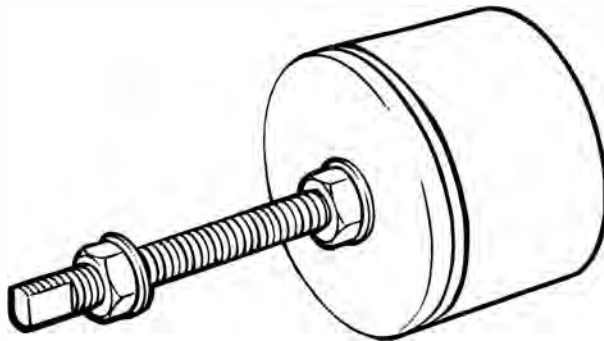

gah, 1

T3880156 - Holder, Balancer Gear

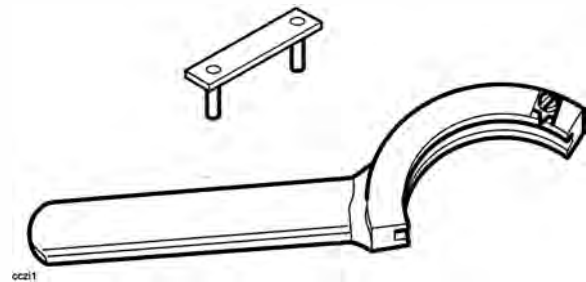

ozz11

# General Information

---

T3880102 - Wrench, Camshaft Turning

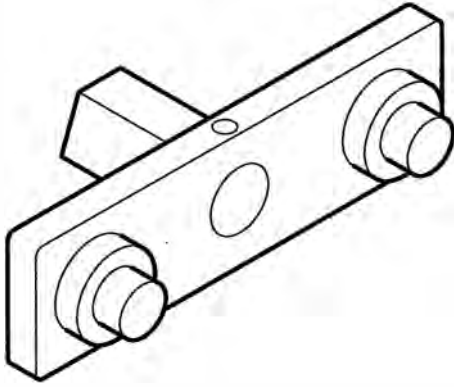

cdpr

T3880026 - Clutch Holding Tool, Universal

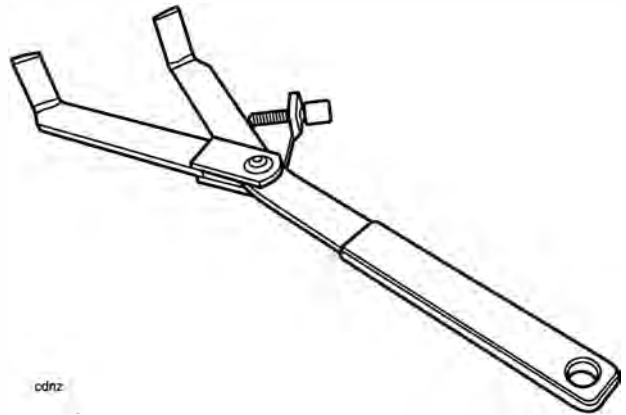

cdnz

T3880365 - Puller, Alternator Rotor



cczh

T3880375 - Alternator Rotor Holder

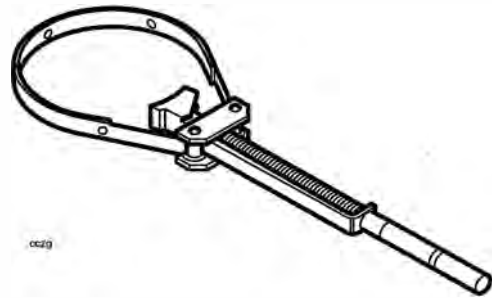

cczq

T3880313 - Oil Filter Wrench



gahc

T3880057 - Engine Management Diagnostics





T3880027 - Chain Link Took Kit

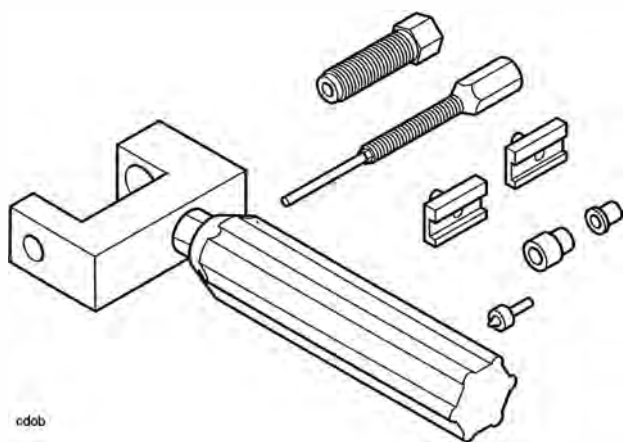

3880160-T0301 - Fork Filler/Evacuator

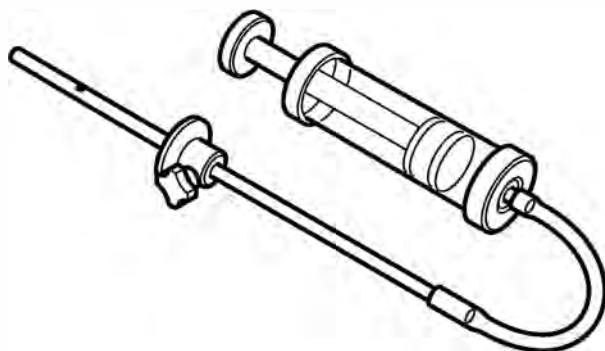

T3880154 - Collet, Nylon, Fork Support - Tiger 800XC

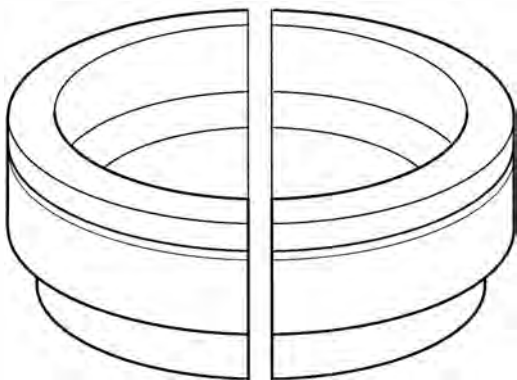

T3880166 - Wrench, Engine Mounting Adjuster

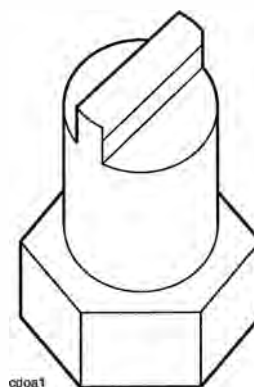

T3880158 - Collet, Nylon, Fork Support - Tiger 800

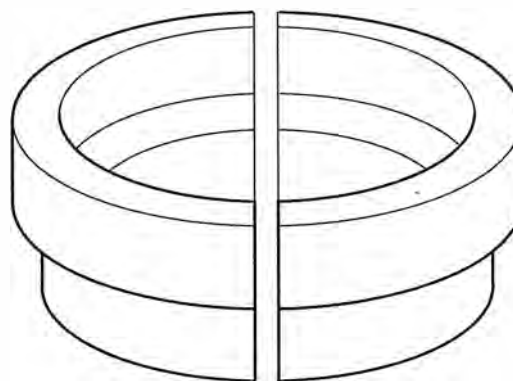

T3880067 - Fork Spring Compressor

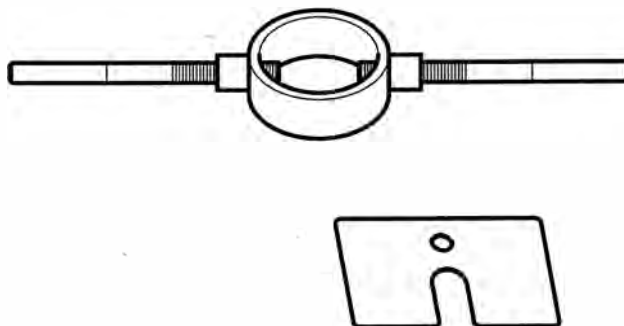

# General Information

T3880153 - Support Plate

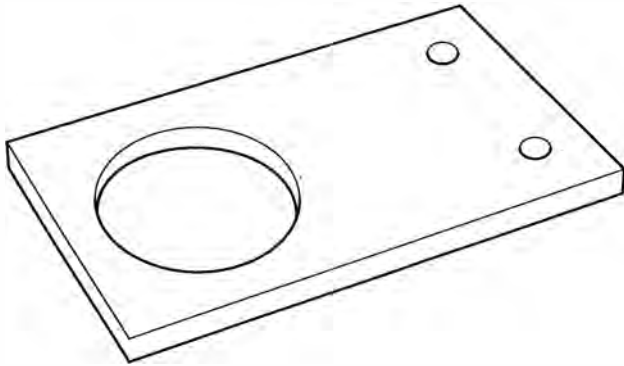

ccxa\_1

T3880157 - Fork Seal and Bush Fitment - Tiger 800XC

T3880003 - Fork Seal and Bush Fitment - Tiger 800

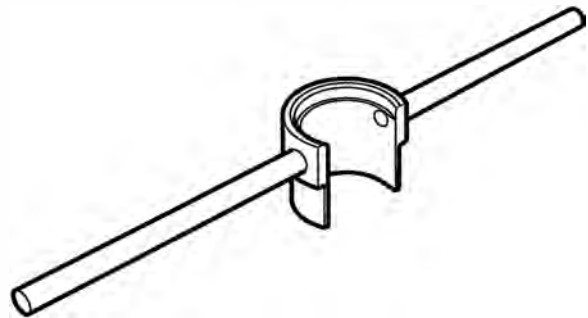

ccxb

T3880053 - Extraction Kit, Wheel Bearing

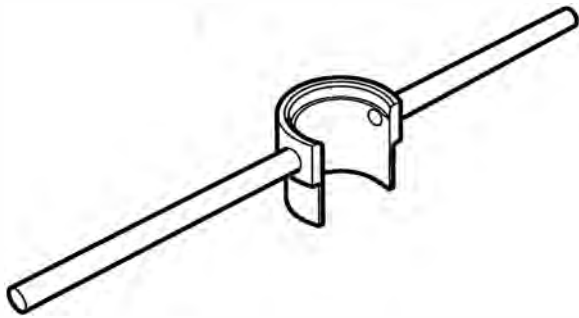

ccxb

3880070 - T0301 - Bearing Installer

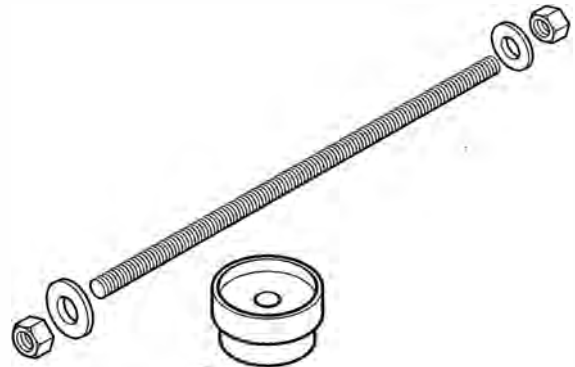

3880065 - T0301 - Bearing Installer



cczb

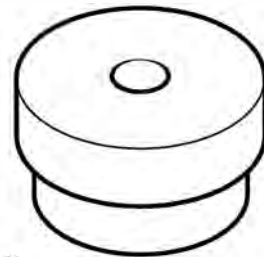

cczb1

T3880023 - Socket 50 mm

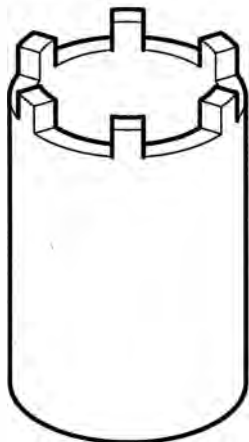

cdbp

T3880123 - Extension Cable

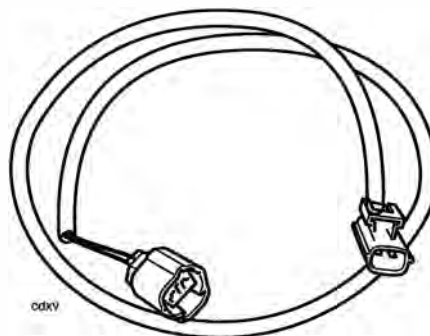

cdkv

BatteryMate Battery Charger - See Latest Parts Catalogue for Part Number Information

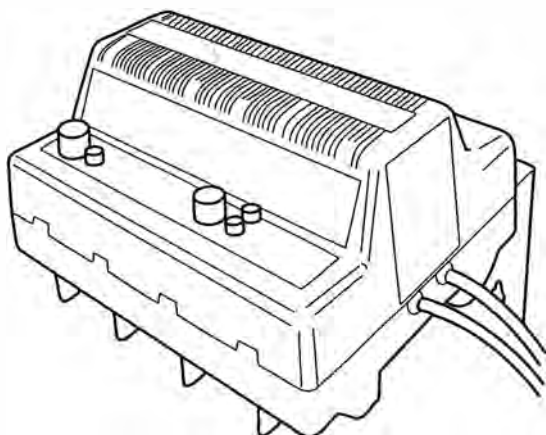

T3880001 - Fuel Pressure Gauge

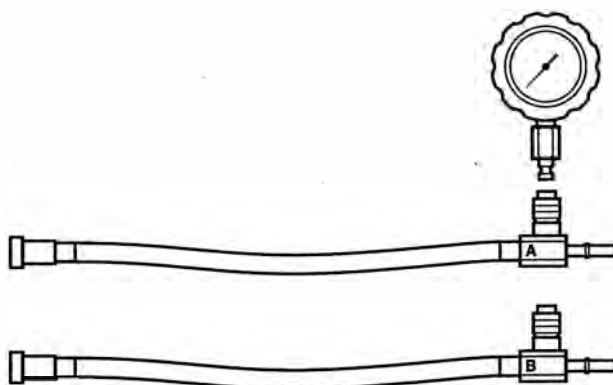

cdkdk

T3880147 - Radiator and Cap Tester

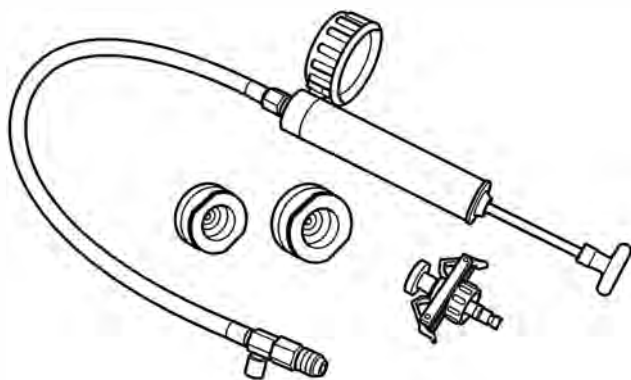

cgwp

# General Information

---

## Full Specification

### Full Specification

### Tiger 800

### Tiger 800XC

#### Engine

Engine Configuration	3 Cylinder 12 valve DOHC	3 Cylinder 12 valve DOHC
Arrangement	Transverse in-line	Transverse in-line
Displacement	800 cc	800 cc
Bore x Stroke	74 x 61.94 mm	74 x 61.94 mm
Compression Ratio	11.1:1	11.1:1
Cylinder numbering	Left to Right (no.3 adjacent to camchain)	Left to Right (no.3 adjacent to camchain)
Cylinder Sequence	Number 1 at left	Number 1 at left
Firing order	1-2-3	1-2-3
Maximum Power	70 kW at 9,300 rpm (95 PS/94 bhp)	70 kW at 9,300 rpm (95 PS/94 bhp)
Maximum Torque	79 Nm at 7,850 rpm (58 lb-ft)	79 Nm at 7,850 rpm (58 lb-ft)

## Full Specification

## Tiger 800

## Tiger 800XC

### Cylinder Head & Valves

Valve Head Diameter	In	30.50 mm	30.50 mm
	Ex	25.50 mm	25.50 mm
Valve Lift	In	7.59 mm	7.59 mm
	Ex	7.25 mm	7.25 mm
Valve Stem Diameter	In	3.975-3.990 mm	3.975-3.990 mm
Service Limit		3.965 mm	3.965 mm
Valve Stem Diameter	Ex	3.955-3.970 mm	3.955-3.970 mm
Service Limit		3.945 mm	3.945 mm
Valve Guide Bore Diameter	In	4.000-4.015 mm	4.000-4.015 mm
Service Limit		4.043 mm	4.043 mm
Valve Guide Bore Diameter	Ex	4.000-4.015 mm	4.000-4.015 mm
Service Limit		4.043 mm	4.043 mm
Valve Stem to Guide Clearance	In	0.010-0.040 mm	0.010-0.040 mm
Service Limit		0.078 mm	0.078 mm
Valve Stem to Guide Clearance	Ex	0.030-0.060 mm	0.030-0.060 mm
Service Limit		0.098 mm	0.098 mm
Valve Seat Width (in head)	In	0.80-1.20 mm	0.80-1.20 mm
Service Limit		1.50 mm	1.50 mm
Valve Seat Width (in head)	Ex	1.00-1.40 mm	1.00-1.40 mm
Service Limit		1.70 mm	1.70 mm
Valve Seat Width (valve)	In	0.99 -1.86 mm	0.99 -1.86 mm
	Ex	1.06 -1.93 mm	1.06 -1.93 mm
Valve Seat Angle		45.25°	45.25°
Inlet/Exhaust Valve Spring 'Load at Length'		508 N +/-25 N at 27.5 mm	508 N +/-25 N at 27.5 mm
Valve Clearance	In	0.10-0.20 mm	0.10-0.20 mm
	Ex	0.325-0.375 mm	0.325-0.375 mm

# General Information

## Full Specification

## Tiger 800

## Tiger 800XC

### Cylinder Head & Valves (continued)

Valve Bucket Diameter	In	25.380 - 25.406 mm	25.380 - 25.406 mm
Service Limit		25.368 mm	25.368 mm
Valve Bucket Diameter	Ex	25.380 - 25.406 mm	25.380 - 25.406 mm
Service Limit		25.368 mm	25.368 mm
Valve Bucket Bore Diameter	In	24.415 - 25.435 mm	24.415 - 25.435 mm
Service Limit		25.449 mm	25.449 mm
Valve Bucket Bore Diameter	Ex	24.415 - 25.435 mm	24.415 - 25.435 mm
Service Limit		25.449 mm	25.449 mm

### Camshafts

Cam Timing	Inlet	Open 5.18° BTDC @ 1.0 mm lift	Open 5.18° BTDC @ 1.0 mm lift
		Close 25.18° ABDC @ 1.0 mm lift	Close 25.18° ABDC @ 1.0 mm lift
	Duration	210.36°	210.36°
	Exhaust	Open 37.27° BBDC @ 1.0 mm lift	Open 37.27° BBDC @ 1.0 mm lift
		Close 3.27° ATDC @ 1.0 mm lift	Close 3.27° ATDC @ 1.0 mm lift
	Duration	220.53°	220.53°
Camshaft Journal Diameter		23.940-23.960 mm	23.940-23.960 mm
Camshaft Journal Clearance		0.040-0.081 mm	0.040-0.081 mm
Service Limit		0.130 mm	0.130 mm
Camshaft Journal Bore Diameter		24.000-24.021 mm	24.000-24.021 mm
Camshaft End Float		0.23-0.33 mm	0.23-0.33 mm
Service Limit		0.40 mm	0.40 mm
Camshaft Run-out		0.015 mm max.	0.015 mm max.

## Full Specification

### Tiger 800

### Tiger 800XC

#### Clutch/Primary Drive

Primary Drive Type	Gear	Gear
Reduction Ratio	1.667:1 (85/51)	1.667:1 (85/51)
Clutch Type	Wet multi-plate	Wet multi-plate
No. of Friction Plates	9	9
Plate Flatness	Within 0.2 mm	Within 0.2 mm
Friction Plate Thickness	3.00 mm	3.00 mm
Service Limit	2.80 mm	2.80 mm
Clutch Actuation Method	Cable	Cable
Clutch Pack Height	42.20 mm (+0.34/-0.66)	42.20 mm (+0.34/-0.66)
Cable Free Play (at lever)	2.0-3.0 mm	2.0-3.0 mm

#### Pistons

Cylinder Bore Diameter	74.040 - 74.060 mm	74.040 - 74.060 mm
Service Limit	74.150 mm	74.150 mm
Piston Diameter (at 90° to gudgeon pin)	73.974 - 73.990 mm	73.974 - 73.990 mm
Service Limit	73.930 mm	73.930 mm
Piston Ring to Groove Clearances		
Top	0.02 - 0.06 mm	0.02 - 0.06 mm
Service Limit	0.075 mm	0.075 mm
Second	0.02 - 0.06 mm	0.02 - 0.06 mm
Service Limit	0.075 mm	0.075 mm
Piston Ring End Gaps		
Top	0.15 - 0.30 mm	0.15 - 0.30 mm
Service Limit	0.60 mm	0.60 mm
Second	0.30 - 0.45 mm	0.30 - 0.45 mm
Service Limit	0.75 mm	0.75 mm
Oil	0.20 - 0.70 mm	0.20 - 0.70 mm
Gudgeon Pin Bore Diameter in Piston	16.004 - 16.012 mm	16.004 - 16.012 mm
Service Limit	16.040 mm	16.040 mm
Gudgeon Pin Diameter	15.995 - 16.000 mm	15.995 - 16.000 mm
Service Limit	15.985 mm	15.985 mm

#### Connecting Rods

Connecting Rod Small End Diameter	16.016 - 16.029 mm	16.016 - 16.029 mm
Service Limit	16.039 mm	16.039 mm
Connecting Rod Big End Side Clearance	0.15 - 0.30 mm	0.15 - 0.30 mm
Service Limit	0.50 mm	0.50 mm

# General Information

## Full Specification

### Tiger 800

### Tiger 800XC

#### Crankshaft

Crankshaft Big End Journal Diameter	32.984-33.000 mm	32.984-33.000 mm
Service Limit	32.960 mm	32.960 mm
Crankshaft Big End Bearing Clearance	0.035-0.065 mm	0.035-0.065 mm
Service Limit	0.070 mm	0.070 mm
Crankshaft Main Bearing Journal Diameter	32.984-33.000 mm	32.984-33.000 mm
Service Limit	32.960 mm	32.960 mm
Crankshaft Main Bearing Clearance	0.020-0.044 mm	0.020-0.044 mm
Service Limit	0.070 mm	0.070 mm
Crankshaft End Float	0.15-0.30 mm	0.15-0.30 mm
Crankshaft Run-out	0.02 mm or less	0.02 mm or less
Service Limit	0.05 mm	0.05 mm

#### Transmission

Type		6 Speed, Constant Mesh	6 Speed, Constant Mesh
Gear Ratios	1st	2.313:1 (37/16)	2.313:1 (37/16)
	2nd	1.857:1 (39/21)	1.857:1 (39/21)
	3rd	1.500:1 (36/24)	1.500:1 (36/24)
	4th	1.285:1 (27/21)	1.285:1 (27/21)
	5th	1.136:1 (25/22)	1.136:1 (25/22)
	6th	1.043:1 (24/23)	1.043:1 (24/23)
Gear Selector Fork Thickness		5.9-6.0 mm	5.9-6.0 mm
Service Limit		5.80 mm	5.80 mm
Gear Selector Groove Width		6.10-6.17 mm	6.10-6.17 mm
Service Limit		6.27 mm	6.27 mm
Gear Selector Fork to Groove Clearance		0.47 mm max.	0.47 mm max.

#### Final Drive

Final Drive	Chain	Chain
Final Drive Ratio	3.125:1 (50/16)	3.125:1 (50/16)
Chain Type	RK O-ring	RK O-ring
Number of Links	122	124
20 Link Length	319 mm	319 mm
Drive Chain Play	15-25 mm	20-30 mm
Chain Lubrication	Chain spray suitable for O-ring chains	Chain spray suitable for O-ring chains



## Full Specification

## Tiger 800

## Tiger 800XC

### Lubrication

Type	Pressure Lubrication, Wet Sump	Pressure Lubrication, Wet Sump
Oil Capacity (dry fill)	3.75 litres	3.75 litres
Oil Capacity (wet fill including filter)	3.6 litres	3.6 litres
Oil Capacity (wet fill excluding filter)	3.4 litres	3.4 litres
Recommended Oil Approval Rating	API SH (or higher) and JASO MA	API SH (or higher) and JASO MA
Viscosity	10W/40 or 10W/50	10W/40 or 10W/50
Type	Semi or fully synthetic	Semi or fully synthetic
Oil pressure (in main gallery)	3.4 bar (49 lb/ft <sup>2</sup> ) min. @ 80°C oil temperature @ 5,000 rpm	3.4 bar (49 lb/ft <sup>2</sup> ) min. @ 80°C oil temperature @ 5,000 rpm
Oil Pump Rotor Tip Clearance	0.15 mm	0.15 mm
Service Limit	0.20 mm	0.20 mm
Oil Pump Body Clearance	0.15-0.22 mm	0.15-0.22 mm
Service Limit	0.35 mm	0.35 mm
Oil Pump Rotor End Float	0.04-0.09 mm	0.04-0.09 mm
Service Limit	0.17 mm	0.17 mm

### Ignition System

Type	Digital Inductive	Digital Inductive
Electronic Rev Limiter	10,000 (rpm)	10,000 (rpm)
Pick-up Coil Resistance	1.0 Ω +/-15% @ 20°C	1.0 Ω +/-15% @ 20°C
Ignition Coil Type	Plug-top	Plug-top
Spark Plug Type	NGK CR9EK	NGK CR9EK
Spark Plug Gap	0.7 mm	0.7 mm

### Fuel System

Fuel Type	Unleaded, 91 RON (U.S. 87 CLC/AKI)	Unleaded, 91 RON (U.S. 87 CLC/AKI)
Fuel Tank Capacity (motorcycle upright)	19 litres	19 litres
Low Level Warning Lamp	4 litres remaining	4 litres remaining
Fuel Pump Type	Submerged	Submerged
Fuel Pressure (nominal)	3.0 bar	3.0 bar
Purge Control System	Electronic, via fuel system ECU	Electronic, via fuel system ECU

## General Information

### Full Specification

### Tiger 800

### Tiger 800XC

#### Coolant System

Coolant Mixture	50/50 (pre-mixed as supplied by Triumph)	50/50 (pre-mixed as supplied by Triumph)
Anti-Freeze Type	Triumph HD4X Hybrid OAT coolant	Triumph HD4X Hybrid OAT coolant
Freezing point	-35°C	-35°C
Cooling System Capacity	2.4 litres	2.4 litres
Radiator Cap Opening Pressure	1.1 bar	1.1 bar
Thermostat Opening Temperature	71°C (nominal)	71°C (nominal)
Cooling Fan Switch On Temperature	103°C	103°C
Temperature Gauge Sensor Resistance	2.3 – 2.6 KΩ @ 20°C	2.3 – 2.6 KΩ @ 20°C

#### Suspension

Front Fork Travel	180 mm	220 mm
Recommended Fork Oil Grade	Showa SS 8	Showa SS 8
Oil Level (fork fully compressed, spring removed)	103 mm	107 mm
Oil Volume (dry fill)	553 cc	619 cc
Fork Pull Through	4 mm	4 mm
Rear Wheel Travel	170 mm	215 mm
Rear Suspension Bearing Grease	Grease to NLGI 2 specification	Grease to NLGI 2 specification

## Full Specification

### Tiger 800

### Tiger 800XC

#### Fuel Injection System

Type	Electronic, sequential	Electronic, sequential
Idle Speed	1,100 rpm	1,100 rpm
Injector Type	Twin jet, solenoid operated plate valve	Twin jet, solenoid operated plate valve
Throttle	Cable/twist grip/electronic throttle potentiometer	Cable/twist grip/electronic throttle potentiometer
Control Sensors	Barometric pressure, throttle position, coolant temperature, crankshaft position, vehicle speed, lambda sensor, intake air temperature, gear position, MAP	Barometric pressure, throttle position, coolant temperature, crankshaft position, vehicle speed, lambda sensor, intake air temperature, gear position, MAP

#### Emissions Controls

Catalysts	1, in down pipe	1, in down pipe
Oxygen sensor	Heated, in down pipe	Heated, in down pipe
Evaporative Control	Activated carbon canister (Certain markets only)	Activated carbon canister (Certain markets only)

#### Brakes

Front Type	Two hydraulically actuated twin piston sliding calipers acting on twin discs	Two hydraulically actuated twin piston sliding calipers acting on twin discs
Caliper Piston Diameter	2 x 27.00 mm	2 x 27.00 mm
Disc Diameter	305 mm	305 mm
Disc Thickness	4.5 mm	4.5 mm
Service Limit	4.0 mm	4.0 mm
Disc Run-out	0.15 mm Max.	0.15 mm Max.
Master Cylinder Diameter	14.00 mm	14.00 mm
Recommended Fluid	DOT 4 Brake and Clutch Fluid	DOT 4 Brake and Clutch Fluid

# General Information

## Full Specification

### Tiger 800

### Tiger 800XC

#### Brakes (continued)

Rear Type	Hydraulically actuated single piston caliper, single disc	Hydraulically actuated single piston caliper, single disc
Caliper Piston Diameter	38.18 mm	38.18 mm
Disc Diameter	255 mm	255 mm
Disc Thickness	6.0 mm	6.0 mm
Service Limit	5.5 mm	5.5 mm
Disc Run-out	0.5 mm Max.	0.5 mm Max.
Master Cylinder Diameter	12.7 mm	12.7 mm
Recommended Fluid	DOT 4 Brake and Clutch Fluid	DOT 4 Brake and Clutch Fluid

#### Wheels and Tyres

Front Wheel Size	MT 2.5 x 17	WM 2.5 x 21
Front Tyre Size	100/90 - 19	90/90 - 21
Front Tyre Pressure	2.5 bar (36 lb/in <sup>2</sup> )	2.5 bar (36 lb/in <sup>2</sup> )
Recommended Front Tyre	Option 1	Pirelli Scorpion Trail
	Option 2	Bridgestone Battle Wing BW501 G
		Pirelli Scorpion Trail
Front Wheel Rim Axial Run-out	0.5 mm	1.0
Front Wheel Rim Radial Run-out	0.5 mm	1.0
Rear Wheel Size	MT 4.25x 17	MT 4.25x 17
Rear Tyre Size	150/70 - 17	150/70 - 17
Rear Tyre Pressure	2.9 bar (42 lb/ft <sup>2</sup> )	MT 4.25 x 17
Recommended Rear Tyres	Option 1	Pirelli Scorpion Trail
	Option 2	Bridgestone Battle Wing BW502
		Pirelli Scorpion Trail
Rear Wheel Rim Axial Run-out	0.5 mm	1.0
Rear Wheel Rim Radial Run-out	0.5 mm	1.0

## Full Specification

### Tiger 800

### Tiger 800XC

#### Frame

Frame Type	Steel trellis	Steel trellis
Overall Length	2215 mm (87.2 in)	2215 mm (87.2 in)
Overall Width	795 mm (31.3 in)	865 mm (34.1 in)
Overall Height	1350 mm (53.1 in)	1390 mm (54.7 in)
Wheelbase	1530 mm (60.2 in)	1545 mm (60.8 in)
Seat Height	813 mm (32.0 in)	847 mm (33.3 in)
Rake	23.9°	24.3°
Trail	92.4 mm	95.3 mm
Wet Weight	210 kg (463 lb)	215 kg (474 lb)
Maximum Payload (rider, passenger, luggage and accessories)	225 kg (496 lb)	223 kg (492 lb)

#### Electrical Equipment

Battery Type	YTX-16BS	YTX-16BS
Battery Rating	12 Volt, 14 Ah	12 Volt, 14 Ah
Alternator Rating	12 Volt, 41.5 Amp at 4,000 rpm	12 Volt, 41.5 Amp at 4,000 rpm
Fuses	See page 17-11	See page 17-11

# General Information

## Torque Wrench Settings

### Cylinder Head Area

Application	Torque (Nm)	Notes
Camshaft cover to cylinder head	10	
Camshaft drive chain tensioner to head	9	
Camshaft bearing ladder to head	*	Refer to section 5
Camshaft sprocket to camshaft	10	Replace fixing(s) if removed
Camshaft drive chain rubbing blade to crankcase	9	Replace fixing(s) if removed
Camshaft drive chain top pad to cylinder head	*	Refer to section 5
Cylinder head to crankcase (M6 screws)	10	Replace fixing(s) if removed
Cylinder head to crankcase bolts	*	Refer to section 3
Camshaft cap and ladder to head	*	Refer to section 3
Cylinder head dry seal plug	22	Replace fixing(s) if removed Apply ThreeBond 1305 to the threads
Sound suppression bolt in head	12	
Spark plugs	12	
Cylinder head exhaust stud	10	Replace fixing(s) if removed

### Clutch

Application	Torque (Nm)	Notes
Clutch cover to crankcase (28 mm bolts)	9	
Clutch cover to crankcase (35 mm bolts)	10	
Clutch centre nut	98	Replace fixing(s) if removed
Clutch pressure plate to centre drum	10	
Clutch lever clamp bolts	12	
Clutch lever nut	3.5	
Clutch cable adjuster bracket to crankcase	12	
Switch cube screws (left)	3	
Clutch cover protector	6	

## Crankshaft, Crankcase and Sprag

Application	Torque (Nm)	Notes
Crankcase upper to lower (M8 fixings)	*	Refer to section 5
Crankcase upper to lower (M6 fixings)	*	Refer to section 5
Crankcase dry seal plug	22	Replace fixing(s) if removed
Breather cover to crankcase	9	Replace fixing(s) if removed
Connecting rod big end nut	*	Refer to section 5
Camshaft drive sprocket gear to crankshaft	27	Replace fixing(s) if removed
Sprag clutch to alternator rotor	Refer to section 7	

## Engine Covers

Application	Torque (Nm)	Notes
Clutch cover to crankcase	9	
Sprocket cover to crankcase	9	
Alternator cover (25 mm bolts) to crankcase	8	
Alternator cover (35 mm bolts) to crankcase	9	
Wire retainer on alternator cover	6	
Crank cover (25 mm bolts) to crankcase	8	
Crank cover (35 mm bolts) to crankcase	9	
Balancer cover to crankcase	8	

## Transmission

Application	Torque (Nm)	Notes
Output sprocket to output shaft	85	Use new tab washers
Detent wheel to selector drum	12	Replace fixing(s) if removed
Detent arm bolt	12	Replace fixing(s) if removed
Input shaft bearing carrier/retainer	12	Replace fixing(s) if removed
Selector shaft retainer	12	Replace fixing(s) if removed
Spring abutment bolt	20	
Gear position sensor	5	Replace fixing(s) if removed
Gear selector arm pinch bolt	9	Replace fixing(s) if removed
Gear pedal pivot bolt	22	
Gear change rod adjuster nuts	6	
Sprag housing to rotor	16	

# General Information

## Lubrication System

Application	Torque (Nm)	Notes
Sump to crankcase	12	
Sump drain plug to sump	25	Replace sealing washer(s) if removed
Oil pressure relief valve to crankcase	15	Apply ThreeBond 1305 to the threads
Low oil pressure warning light switch to crankcase	13	Replace sealing washer(s) if removed
Oil filter to adapter	10	
Heat exchanger to crankcase	59	Replace sealing washer(s) if removed
Oil pump drive chain retainer plate	9	Replace fixing(s) if removed
Oil pump to crankcase	12	Replace fixing(s) if removed
Oil pump drive sprocket to pump shaft	12	Apply ThreeBond 1374 to the threads
Oil pump rotor cover to pump body bolts	12	
Oil pump pick up pipe	12	
Oil transfer pipe	12	
Water pump cover to oil pump body bolts	12	
Transmission oil feed pipes to crankcase	8	Replace fixing(s) if removed
Breather drain tube	9	

## Final Drive

Application	Torque (Nm)	Notes
Rear sprocket to cush drive	55	
Chain guard bolts	9	
Chain rubbing strip to swinging arm	9	



## Cooling System

Application	Torque (Nm)	Notes
Radiator to frame	6	
Coolant bypass to head	15	
Thermostat housing to head	9	
Water elbow to crankcase (left hand)	9	
Water elbow to crankcase (right hand and upper fixing only)	12	
Fan shroud to radiator	2.5	
Water temperature sensor	18	
Radiator lower bracket to radiator	6	
Radiator lower bracket to water outlet bracket	6	
Expansion tank to frame	3	
Expansion tank cover to frame	3	
Radiator bleed screw	1.5	
Top hose bleed screw	1	
Water pump outlet pipe	12	Replace fixing(s) if removed
Water pump inlet pipe	12	Replace fixing(s) if removed
Coolant hose clips	2	

# General Information

## Fuel System, Exhaust System and Airbox

Application	Torque (Nm)	Notes
Fuel tank to frame (rear fixing)	12	
Fuel cap to fuel tank	4	
Fuel pump mounting plate to fuel tank	9	
Throttle body transition piece to cylinder head	12	
Throttle body adaptor clip	1.5	
Fuel rail to throttle body	3.5	
Throttle position sensor	2	
Idle speed control stepper motor	3.5	
Throttle cable bracket to throttle body	3.5	
Throttle cable guide screws	3	
Exhaust downpipe to cylinder head	*	Refer to section 10
Exhaust downpipe to frame	19	
Silencer heat shield	5	Torque every service
Silencer to frame	15	
Silencer rear finisher	5	Apply ThreeBond 1305 to the threads
Silencer front finisher	5	
Silencer clamp to intermediate pipe	10	
Oxygen sensor	25	
Catalytic converter heat shield	5	
Air filter cover to housing	1.5	
Airbox to breather housing	9	
Air filter to housing	1	
Air intake trumpet to airbox	6	
Air temperature sensor	1.5	
Manifold air pressure (MAP) sensor	1.5	
Barometric pressure sensor	1.5	
Fall detection switch	3	Replace fixing(s) if removed
Crankshaft sensor	4	Replace fixing(s) if removed
Road speed sensor	9	Replace fixing(s) if removed
Evaporative canister to bracket	8	
Evaporative bracket to frame	9	

## Rear Suspension

Application	Torque (Nm)	Notes
Swinging arm spindle nut	110	Replace fixing(s) if removed (locknut)
Chain rubbing strip to swinging arm	9	
Rear suspension unit upper mounting bolt	48	
Rear suspension unit lower mounting bolt to drop link	80	
Rear suspension reservoir	3	
Drag link pivot at frame	80	
Drop links to swinging arm	80	
Chain guard (upper and lower)	9	

## Front Suspension

Application	Torque (Nm)	Notes
Upper yoke pinch bolt	20	
Lower yoke pinch bolt	20	
Upper yoke centre nut	90	
Fork top cap	35	
Damping cylinder bolt	20	Replace sealing washer(s) if removed
Damping rod to top cap	20	
Handlebar clamp riser to top yoke (10 mm bolt)	35	
Handlebar upper clamp to lower clamp (8 mm bolt)	26	Lubricate threads with engine oil
Handlebar end weights	5	
Switch cube screws	3	
Mirror	25	

## Wheels

Application	Torque (Nm)	Notes
Front wheel spindle/axle bolt	65	
Front wheel spindle pinch bolts	22	
Rear wheel spindle	110	
Chain adjuster locknut	15	
Rear sprocket to cush drive	55	Replace fixing(s) if removed

# General Information

## Front Brakes

Application	Torque (Nm)	Notes
Front brake caliper to fork	28	
Front brake pad retaining pin	18	
Front brake pad retaining pin plug	3	
Front brake caliper bleed screw	6	
Front brake hose to caliper	25	Replace sealing washer(s) if removed
Front brake master cylinder to handlebar	12	
Front brake hose to master cylinder	25	Replace sealing washer(s) if removed
Front brake disc to wheel	22	Replace fixing(s) if removed
Brake lever pivot bolt	1	
Brake lever pivot bolt locknut	6	
Master cylinder brake hose clamp to fork leg	6	
Brake hose wire guide	7	

## Rear Brakes

Application	Torque (Nm)	Notes
Rear brake caliper to carrier	22	
Rear brake caliper sliding bolt	27	
Rear brake pad retaining pin	18	
Rear brake pad retaining pin plug	3	
Rear brake caliper bleed screw	6	
Rear brake hose to caliper	25	Replace sealing washer(s) if removed
Rear brake master cylinder to frame	16	
Rear brake master cylinder reservoir to mounting	7	
Rear brake master cylinder pushrod locknut	18	
Rear brake light switch	15	Replace sealing washer(s) if removed
Brake pedal pivot bolt	22	
Brake hose P-clip bolt	6	
Rear brake disc to wheel	22	Replace fixing(s) if removed

## ABS System

Application	Torque (Nm)	Notes
ABS module to bracket	9	
ABS bracket to frame	9	
ABS pulser ring to brake disc	5	Replace fixing(s) if removed
ABS sensor to bracket	9	Replace fixing(s) if removed
ABS lines to modulator	25	
ABS hard line to front brake hose	17	

## Frame, Footrests, Control Plates and Engine Mountings

Application	Torque (Nm)	Notes
Lower crankcase to frame	48	Refer to section 9
Cylinder head to frame	48	Refer to section 9
Heel guard to frame	12	
Side stand mounting bracket	45	
Side stand pivot bolt	20	
Side stand pivot bolt	45	
Side stand switch	7	Replace fixing(s) if removed
Seat lock to frame	5	
Front subframe	15	
Lower rear engine mounting frame adjuster	3	

# General Information

---

## Electrical

Application	Torque (Nm)	Notes
Alternator rotor to crankshaft	120	
Alternator stator to cover	12	Replace fixing(s) if removed
Alternator regulator to bracket	9	
Starter motor to crankcase	10	
Starter motor power lead connection	3	
Starter motor solenoid lead connection	5	
Spark plug to cylinder head	12	
Horn	18	
Immobiliser ECU	9	
Ignition switch	12	Replace fixing(s) if removed
Instrument assembly	2	
Headlight	3.5	
Headlight bezel	3	
Rear light	4	
Front and rear indicator	3	
Negative battery lead to upper crankcase	9	

## Bodywork

Application	Torque (Nm)	Notes
Mudguard extension bracket	9	Replace fixing(s) if removed
Front mudguard to forks - Tiger 800	6	Replace fixing(s) if removed
Front mudguard to forks - lower - Tiger 800XC	6	Replace fixing(s) if removed
Front mudguard to forks - upper - Tiger 800XC	6	Replace fixing(s) if removed
Handguard bracket to lever pivot bolt	1	
Handguard to bracket	9	
Handguard to handlebar spacer	6	Replace fixing(s) if removed
Sumpguard nuts	10	
Sumpguard rubber to sump	3	
Sumpguard Bracket	15	
Sumpguard front bolts	15	Replace fixing(s) if removed
Screen fixings to brackets	3	
Screen bracket (pressed, at side)	5	
Screen bracket (cast, at front)	5	
Centre panel (Tiger 800) or Beak support moulding (Tiger 800XC) to subframe (nut and screw)	5	
Beak to beak support moulding	3	
Beak support moulding to subframe	5	
Cockpit infill panels to cockpit moulding	3	
Ignition switch cover	5	
Fuel tank panel, front	5	
Lower radiator panel	3	
Upper radiator panel	5	
Radiator infill panel lower fixing	6	Replace fixing(s) if removed
Radiator infill panel upper fixing	3	Replace fixing(s) if removed
Battery tray	6	Apply ThreeBond 1360 to the threads
Rear mudguard upper fixing	3	
Rear mudguard lower fixing	5	Replace fixing(s) if removed
Rear mudguard splash cover	3	
Rear panel M6 bolts	5	
Rear panel M8 bolts	20	
Grab rail to subframe bolts	20	
Rear rack	3	
Front seat bridge	5	
Fuel tank infill	3	
Rear seat bracket lower fixing	5	
Rear seat bracket upper fixing	5	

# General Information

## Clutch Cable Routing

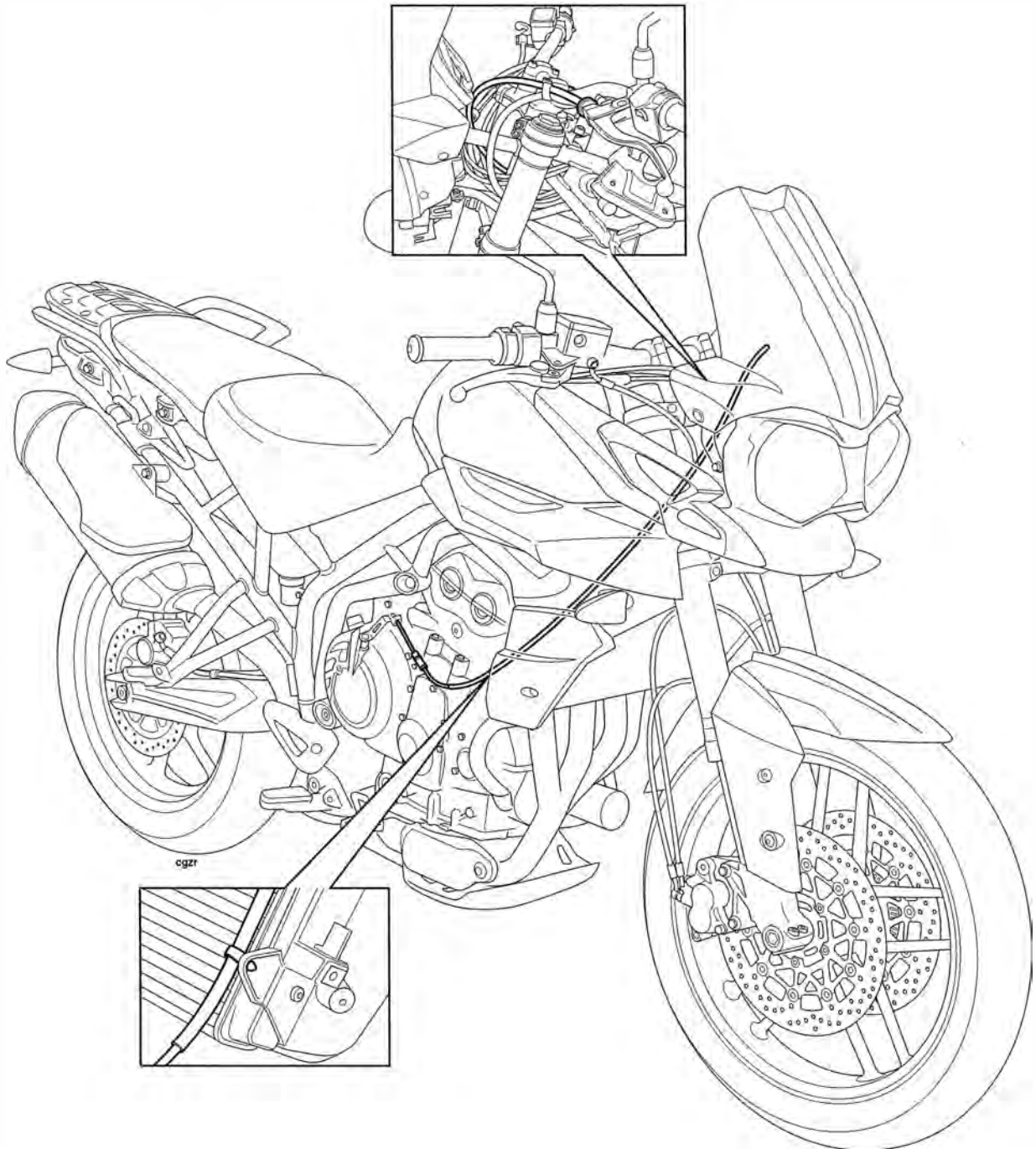



Throttle Cable Routing

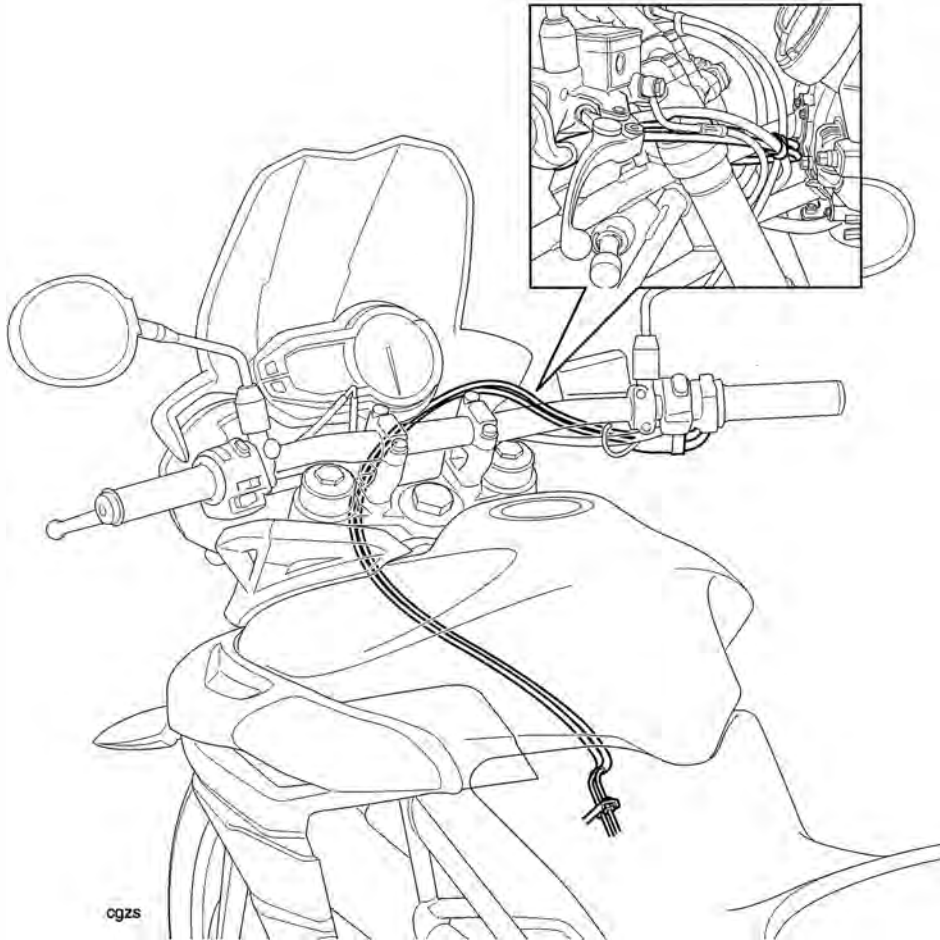

# General Information

## Main Wiring Harness Routing

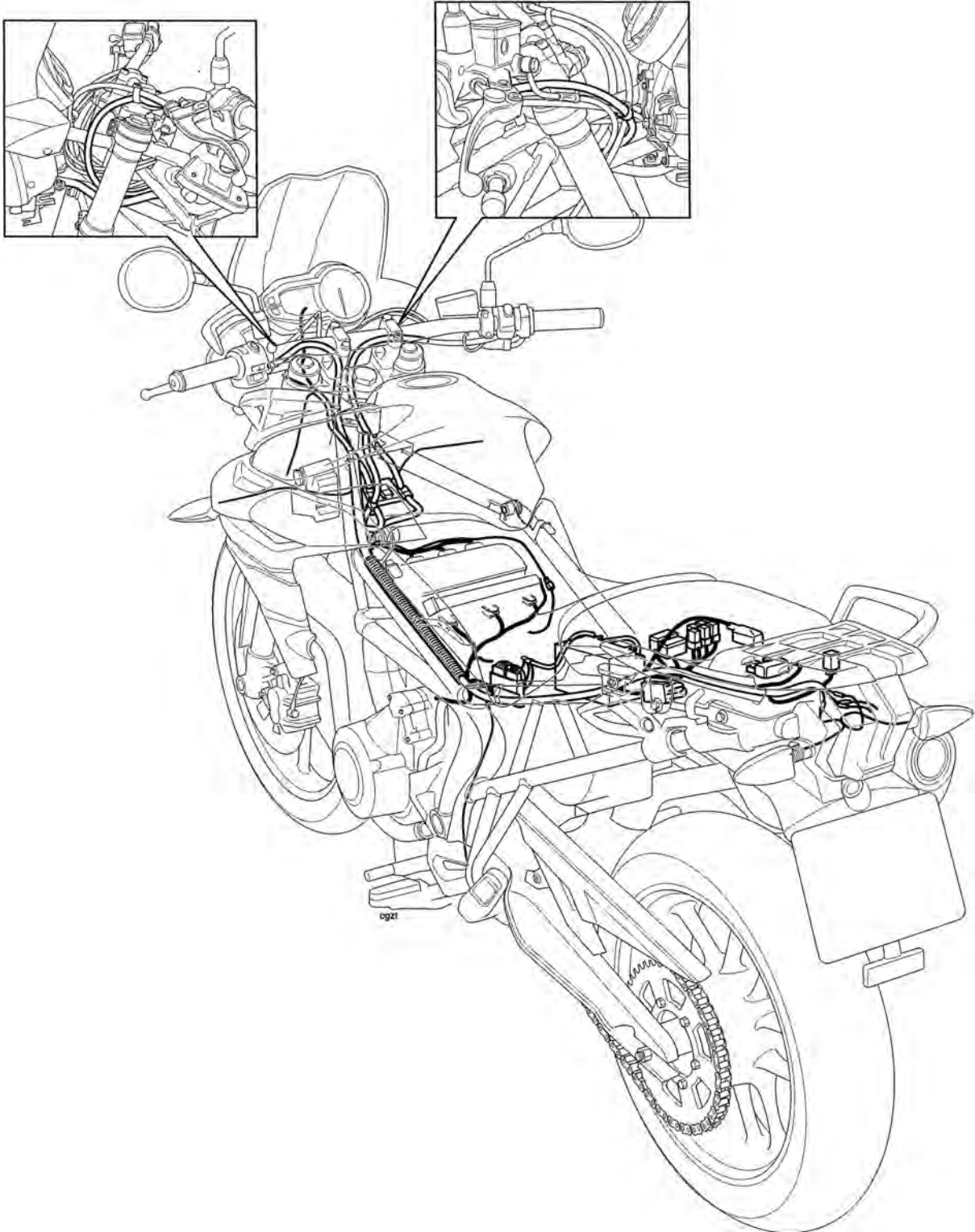

**Front and Rear Brake Hose Routing - Models Without ABS**

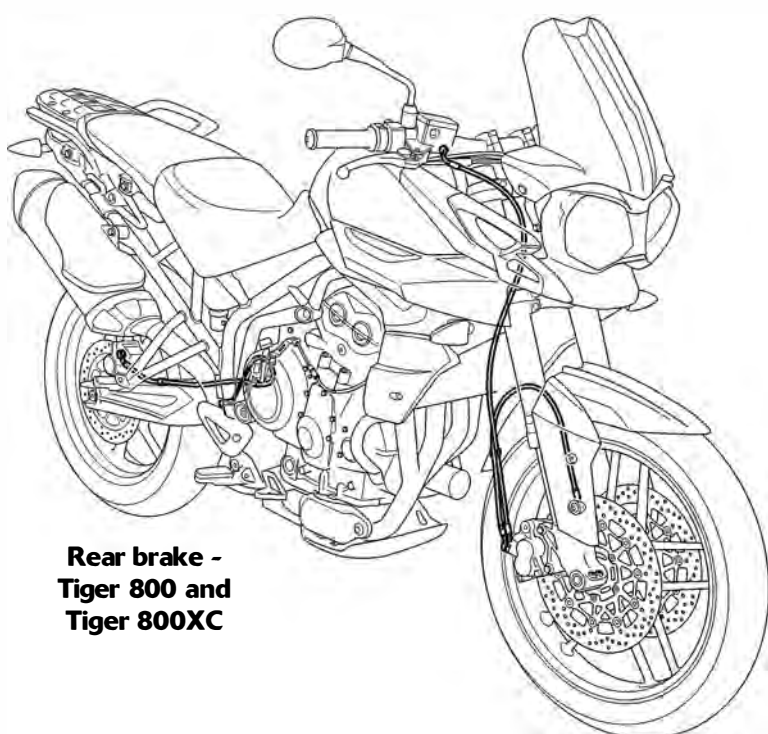

**Rear brake -  
Tiger 800 and  
Tiger 800XC**



**Front Brake -  
Tiger 800**

**Front Brake -  
Tiger 800XC**

# General Information

## ABS Hose Routing

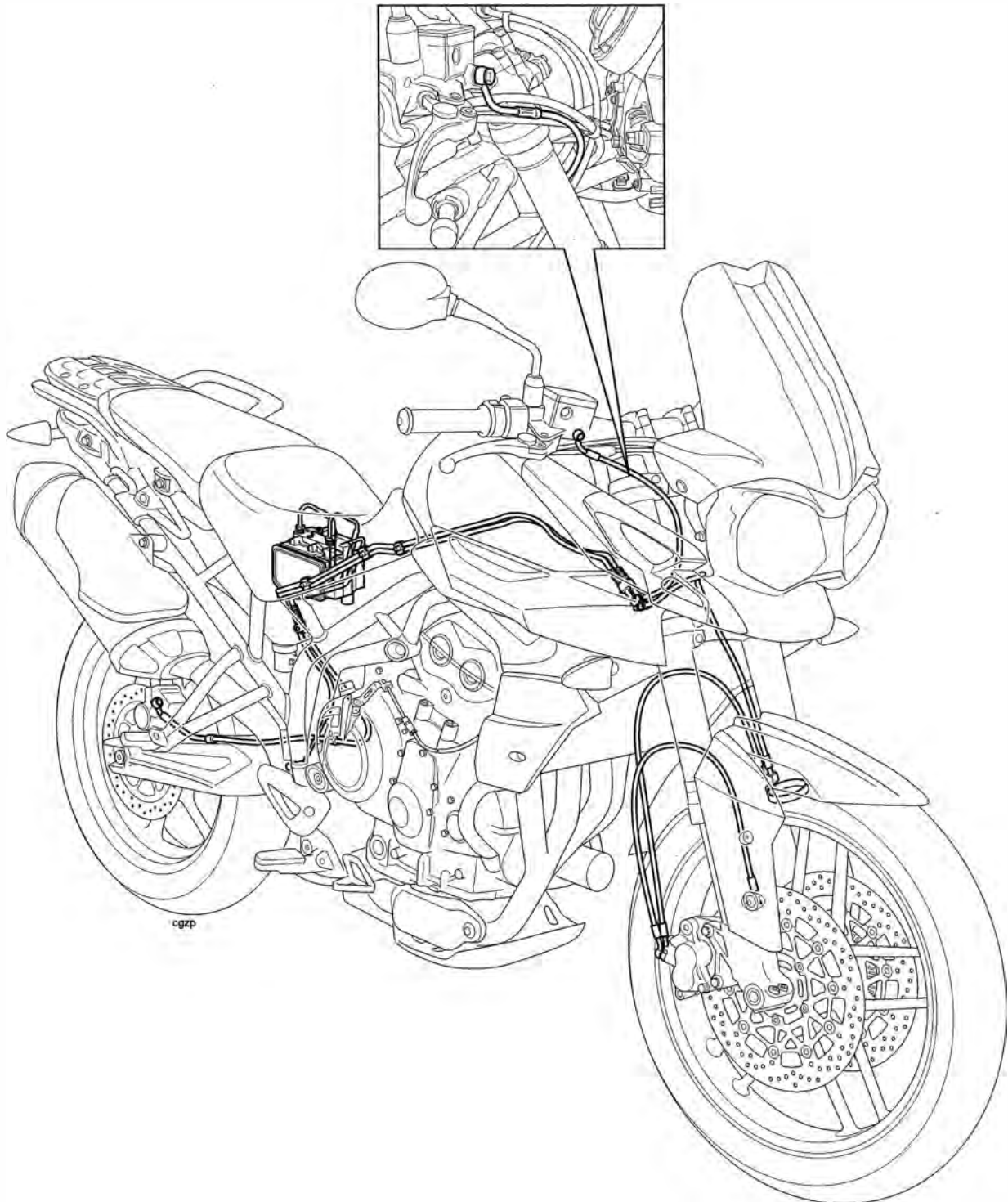

Fuel Tank Breather Hose Routing

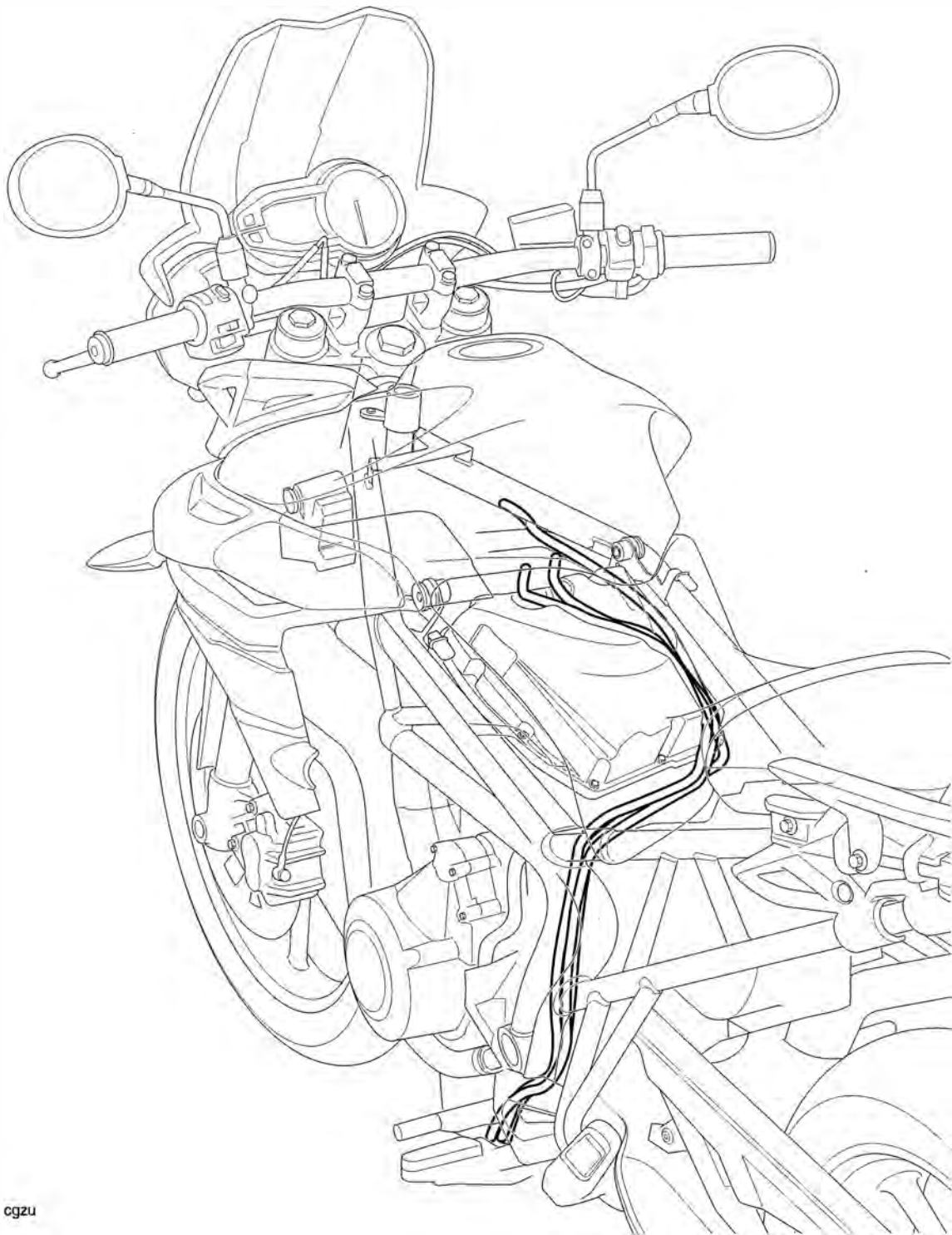

cgzu

This page intentionally left blank

# 2 Scheduled Maintenance

## Table of Contents

Introduction .....	2.2
Scheduled Maintenance Chart .....	2.3

# Scheduled Maintenance

---

## Introduction

To maintain the motorcycle in a safe and reliable condition, the maintenance and adjustments outlined in this section must be carried out as specified in the schedule of daily checks, and also in line with the scheduled maintenance chart.

Weather, terrain and geographical location affects maintenance. The maintenance schedule should be adjusted to match the particular environment in which the vehicle is used and the demands of the individual owner. For advice on adjusting the service schedule, consult your authorised Triumph dealer.

### **Warning**

In order to correctly carry out the maintenance items listed in the scheduled maintenance chart, special tools and specialist knowledge will be required. As only an authorised Triumph dealer will have this knowledge and equipment, Triumph strongly recommends that your authorised Triumph dealer carries out all scheduled maintenance.

A dangerous riding condition could result from incorrect maintenance leading to loss of motorcycle control and an accident.

### **Warning**

All maintenance is vitally important and must not be neglected. Incorrect maintenance or adjustment may cause one or more parts of the motorcycle to malfunction. A malfunctioning motorcycle is dangerous and may lead to an accident.

### **Warning**

Triumph Motorcycles cannot accept any responsibility for damage or injury resulting from incorrect maintenance or improper adjustment carried out by the owner.

Since incorrect or neglected maintenance can lead to a dangerous riding condition, always have an authorised Triumph dealer carry out the scheduled maintenance of this motorcycle.



## Scheduled Maintenance Chart

Operation Description		Odometer Reading in Miles (Kms) or time period, whichever comes first				
		First Service	A Service	B Service	C Service	D Service
		500 (800) 1 month	6,000 (10,000) 1 year	12,000 (20,000) 2 years	18,000 (30,000) 3 years	24,000 (40,000) 4 years
Engine oil cooler - check for leaks	Day	•	•	•	•	•
Engine oil - renew	-	•	•	•	•	•
Engine oil filter - renew	-	•	•	•	•	•
Valve clearances - check	-			•		•
Air cleaner - renew	-			•		•
Autoscan - carry out a full Autoscan using the Triumph diagnostic tool	-	•		•		•
Engine ECM - check for stored DTCs	-	•	•		•	
ABS ECM - check for stored DTCs	-	•	•	•	•	•
Spark plugs - check	-		•		•	
Spark plugs - renew	-			•		•
Throttle bodies - balance	-		•	•	•	•
Throttle cables - check/adjust	Day	•	•	•	•	•
Cooling system - check for leaks	Day	•	•	•	•	•
Coolant level - check/adjust	Day	•	•		•	
Coolant - renew	-			•		•
Fuel system - check for leaks	Day	•	•	•	•	•
Lights, instruments & electrical systems - check	Day	•	•	•	•	•
Steering - check for free operation	Day	•	•	•	•	•
Headstock bearings - check/adjust	-		•	•	•	•
Headstock bearings - lubricate	-			•		•
Forks - check for leaks/smooth operation	Day	•	•	•	•	•
Fork oil - renew	-					•
Brake fluid levels - check	Day	•	•	•	•	•
Brake fluid - renew	-			•		•
Brake pad wear - check	Day	•	•	•	•	•
Brake master cylinders – check for oil leaks	Day	•	•	•	•	•
Brake calipers - check for leaks and seized pistons	Day	•	•	•	•	•
Rear suspension linkage - check/lubricate	-			•		•
Drive chain - lubricate		Every 200 miles (300 kms)				
Drive chain - wear check		Every 500miles (800kms)				
Drive chain slack - check/adjust	Day	•	•	•	•	•
Drive rubbing strip - renew	-		•	•	•	•
Fasteners - inspect visually for security	Day	•	•	•	•	•
Wheels - inspect for damage	Day	•	•	•	•	•
Wheels - check wheels for broken or damaged spokes and check spoke tightness (Tiger 800XC models only)	Day	•	•	•	•	•
Wheel bearings - check for wear/smooth operation	-	•	•	•	•	•

## Scheduled Maintenance

Operation Description	Every	Odometer Reading in Miles (Kms) or time period, whichever comes first				
		500 (800) 1 month	6,000 (10,000) 1 year	12,000 (20,000) 2 years	18,000 (30,000) 3 years	24,000 (40,000) 4 years
Tyre wear/tyre damage - check	Day	•	•	•	•	•
Tyre pressures - check/adjust	Day	•	•	•	•	•
Clutch cable - check/adjust	Day	•	•	•	•	•
Stand - check operation	Day	•	•	•	•	•
Secondary exhaust clamp bolts - check/adjust	-	•	•	•	•	•
Accessory rack sliding carriage - check for correct operation‡	-	•	•	•	•	•
Accessory pannier link bar - check for correct operation and adjustment‡	-	•	•	•	•	•
Fuel and evaporative loss* hoses - renew	-					•

\*Evaporative system fitted to California models only.

‡Only if fitted.

# 3 Cylinder Head

## Table of Contents

Exploded View - Cylinder Head and Valves.....	3.3
Exploded View - Camshaft Cover.....	3.4
Exploded View - Camshaft and Camshaft Drive.....	3.5
Cylinder Head Description.....	3.6
Camshaft Cover.....	3.6
Removal.....	3.6
Installation.....	3.7
Camshaft Drive Chain Tensioner - all Models.....	3.8
Removal.....	3.8
Installation.....	3.9
Camshaft Drive Chain Tensioner Blade.....	3.12
Disassembly.....	3.12
Assembly.....	3.12
Camshafts.....	3.13
Removal.....	3.13
Camshaft and Bearing Cap Inspection.....	3.14
Installation.....	3.15
Stage 1.....	3.15
Stage 2.....	3.16
Valve Clearances.....	3.17
Valve Clearance Measurement.....	3.17
Valve Clearance Adjustment.....	3.18
Camshaft Drive Chain.....	3.18
Removal.....	3.18
Inspection.....	3.19
Installation.....	3.20
Cylinder Head.....	3.20
Removal.....	3.20
Inspection.....	3.21
Installation.....	3.22
Valves and Valve Stem Seals.....	3.23
Removal from the Cylinder Head.....	3.23
Installation.....	3.24

# Cylinder Head

---

Valve to Valve Guide Clearance.....	3.25
Valve Guides .....	3.25
Valve Face Inspection .....	3.25

## Exploded View - Cylinder Head and Valves

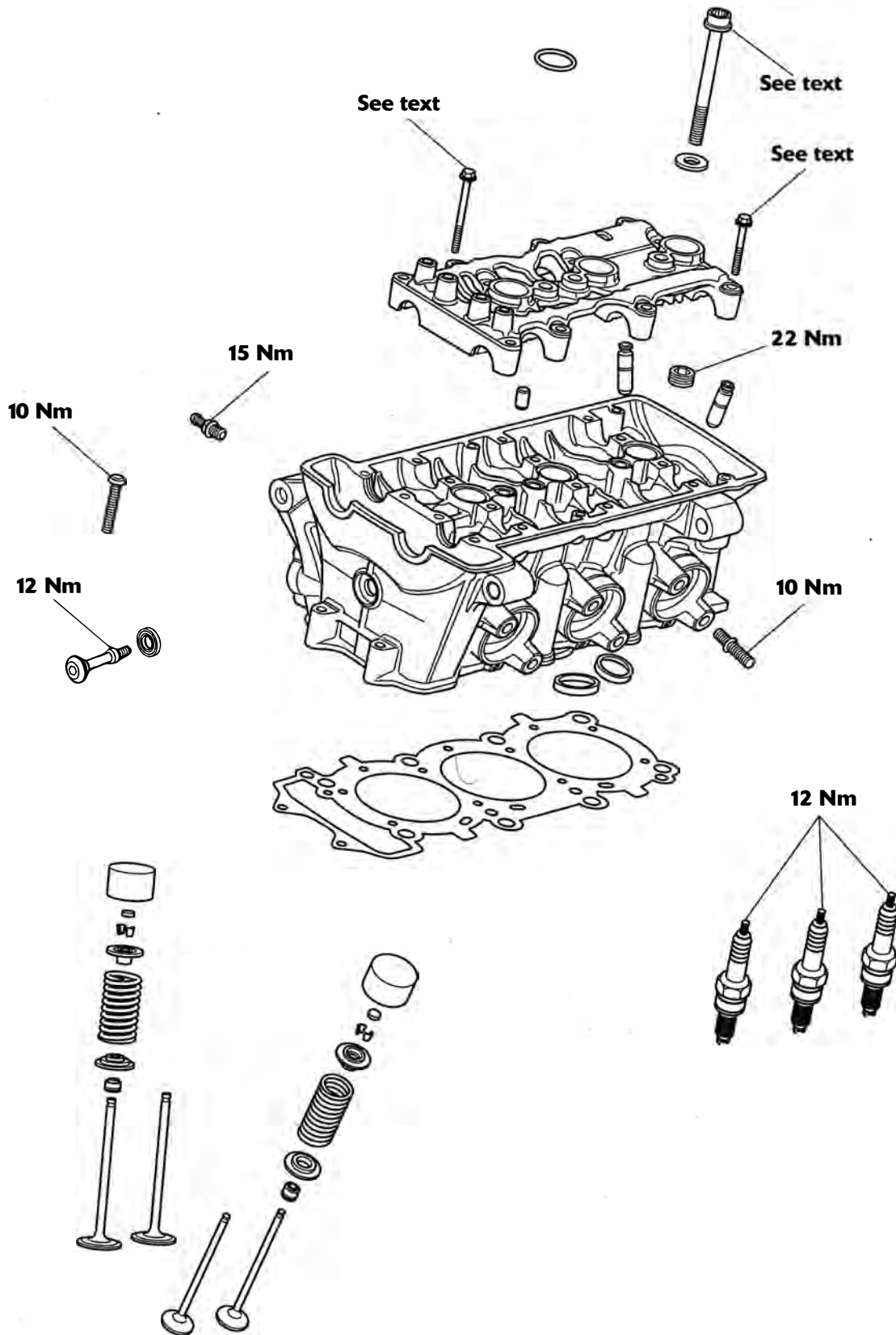

# Cylinder Head

## Exploded View - Camshaft Cover

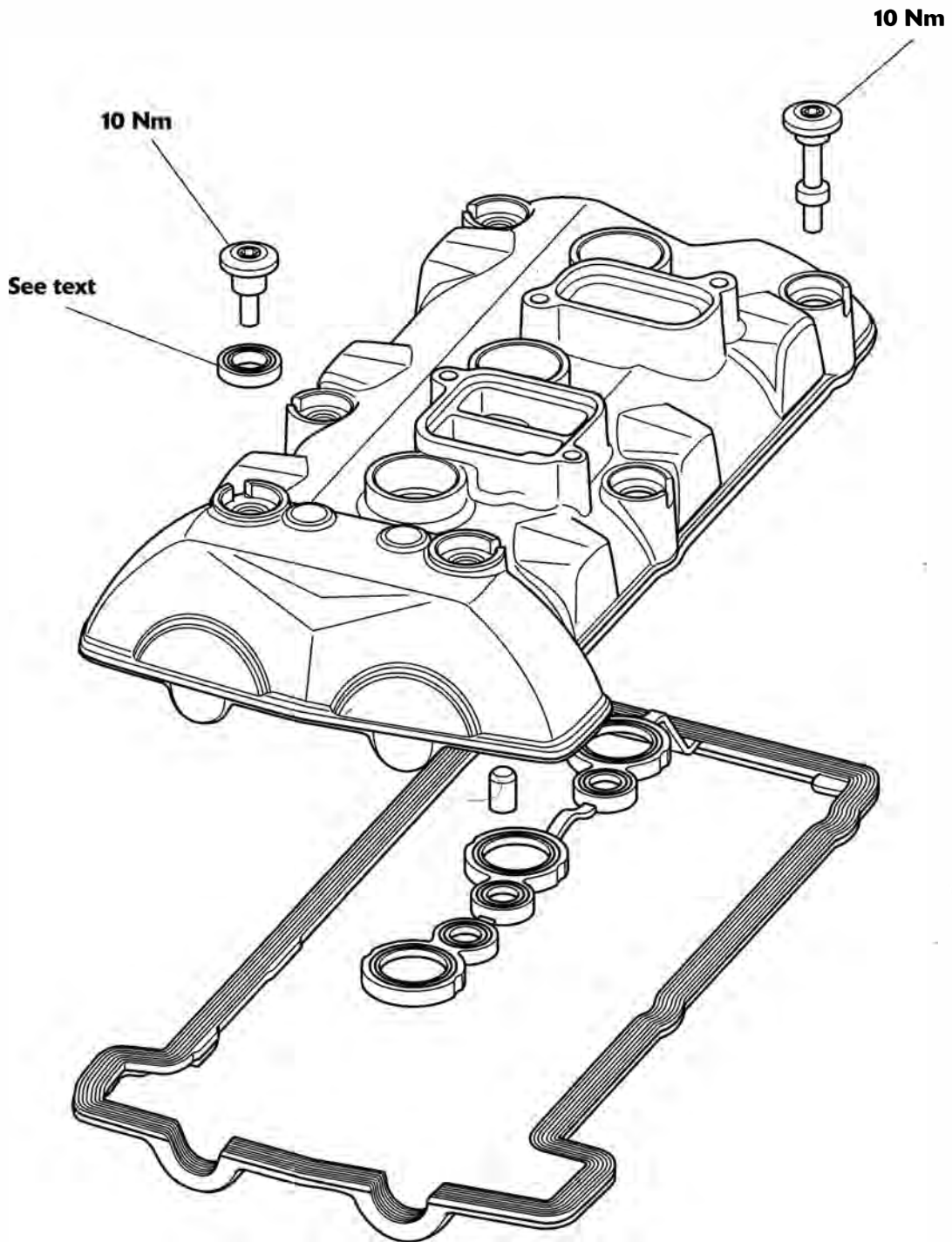

Exploded View - Camshaft and Camshaft Drive

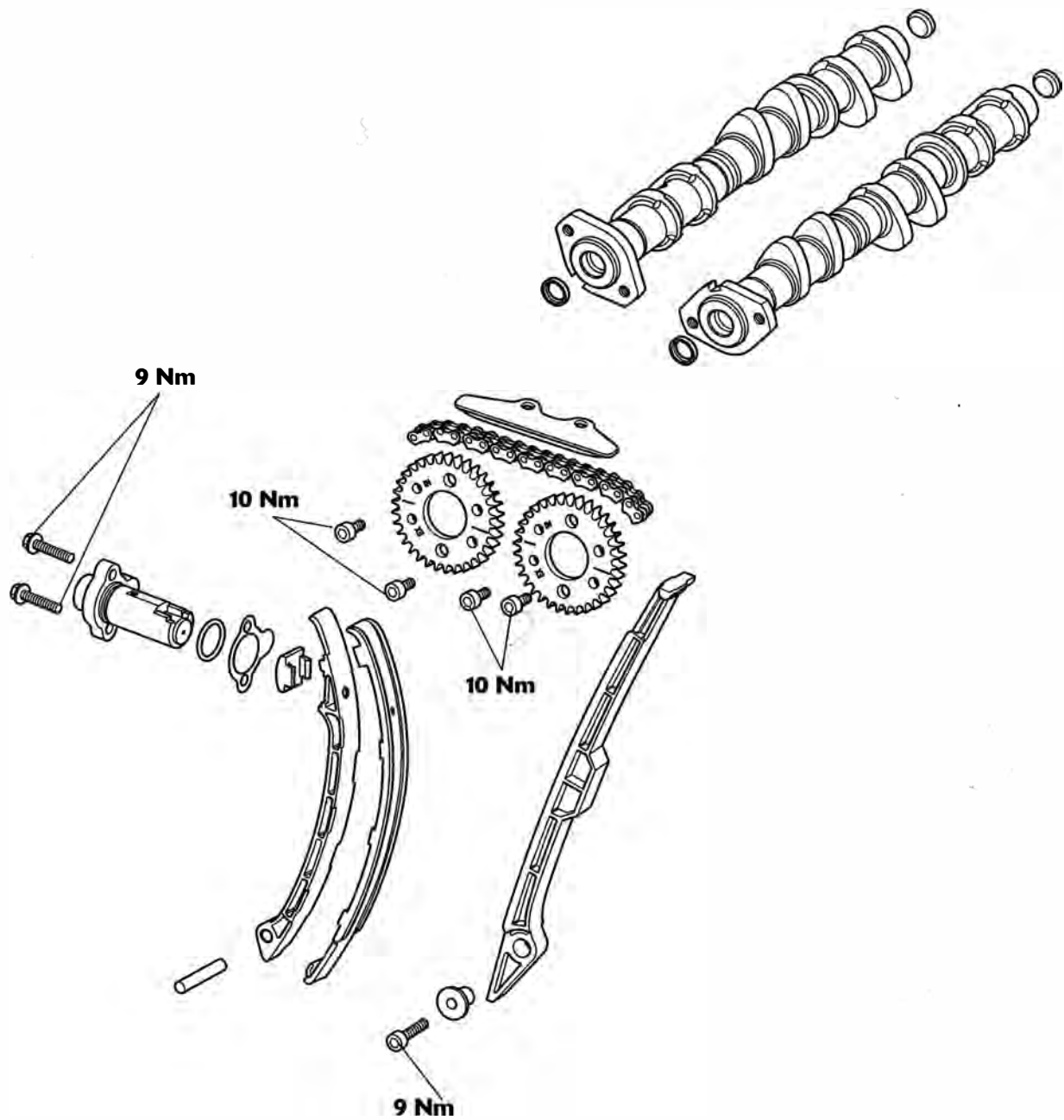

# Cylinder Head

## Cylinder Head Description

The engine is fitted with an aluminium alloy cylinder head, which carries the camshafts, valves and spark plugs. The cylinder head is cast as a single entity and various components are permanently added after machining.

The camshafts run directly in the head without separate bearings. Valve clearances are adjusted by changing variable thickness shims which sit between the valve tappet bucket and the valves.

The camshafts are driven by a silent-type chain. The chain is guided by two blades and is tensioned by a hydraulic tensioner.

The Hydraulic tensioner is fed oil via a gallery in the cylinder head. The combination of oil pressure and spring pressure pushes the plunger against the tensioner blade which tensions the camshaft drive chain. The hydraulic tensioner has an oil pressure relief valve located in the plunger that is set to open between 12 - 16 bar and when opens sprays oil through a drilling in the tensioner blade onto the camshaft drive chain.

Oil is supplied to the head by an internal gallery. Once supplied to the head, the oil is distributed along internal drillings within the head casting and camshaft.

Single valve springs are used to close both the inlet and exhaust valves. These valve springs have close wound coils at one end to assist in the prevention of valve bounce at high engine speed and to give a smooth valve actuation. When assembling the cylinder head it is important that the close wound, colour coded ends of the springs are fitted downwards (towards the piston). The tip of the inlet and exhaust valves are hardened to give a long service life.

Due to the methods used to assemble the valve seat and valve guides to the head, these parts cannot be replaced.

### Caution

In any of the following operations which necessitate the removal or disconnection of the camshaft drive chain, NEVER turn the engine without the camshaft drive chain and tensioner correctly fitted and adjusted. In the disassembled condition, the pistons will contact the valves if the crankshaft is turned, causing severe engine damage.

## Camshaft Cover

### Removal

1. Remove the rider's seat (see page 16-13).
2. Disconnect the battery, negative (black) lead first.
3. Remove the fuel tank (see page 10-91).
4. Remove the airbox (see page 10-98).
5. Remove the ignition coils from the camshaft cover.

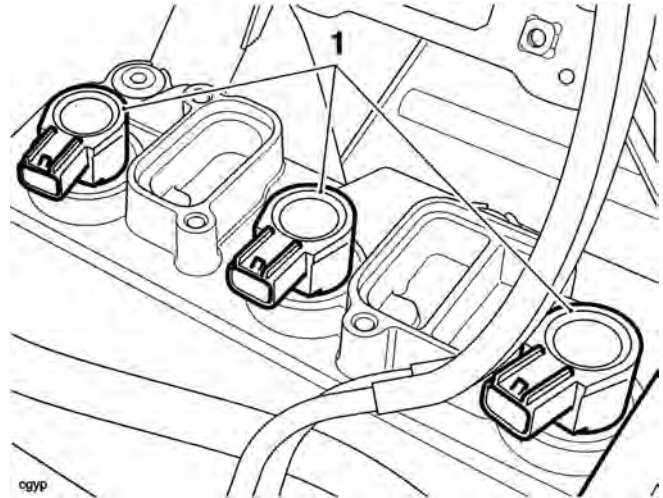

### 1. Ignition coils

6. Remove the throttle bodies, injectors and fuel rail from the cylinder head (see page 10-107).

### Note:

- **It is not necessary to disconnect the throttle cables. Instead, lay the assembly over the frame during the period when the engine is separated from the frame.**

7. Progressively release the camshaft cover bolts in the sequence shown below.



## Note:

- Two shorter bolts are fitted at the end adjacent to the camshaft drive chain.

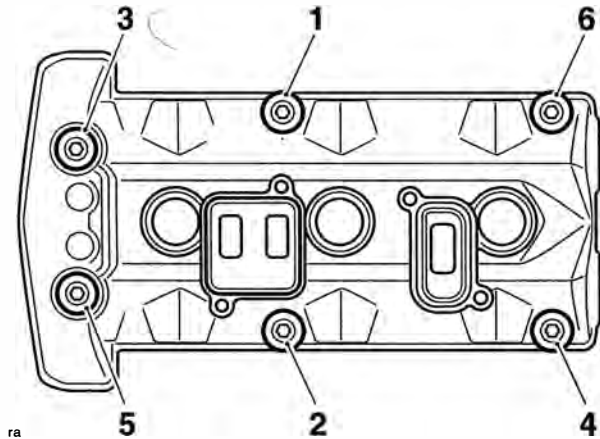

### Camshaft Cover Bolt Release Sequence

8. Remove the camshaft cover from the motorcycle.

## ⚠ Caution

Never use a lever to remove the camshaft cover from the head.

Using a lever will cause damage to the head and camshaft cover which could lead to an oil leak.

9. Remove the camshaft cover gasket. If necessary, recover the three dowels from the camshaft ladder (these may come away in the camshaft cover or gasket).
10. Discard the camshaft cover gasket and bolt seals.
11. Remove any residual oil from the front of the head using a syringe or lint free cloth.

## Installation

1. Refit the three dowels to the camshaft ladder.

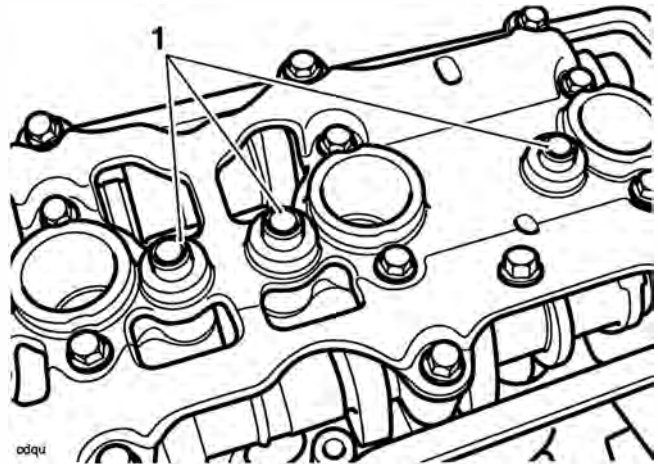

### 1. Dowels

2. Fit a new camshaft cover seal to the cylinder head. Ensure the groove in the gasket is correctly seated to the head. Ensure the plug tower seals and the dowels are correctly located.

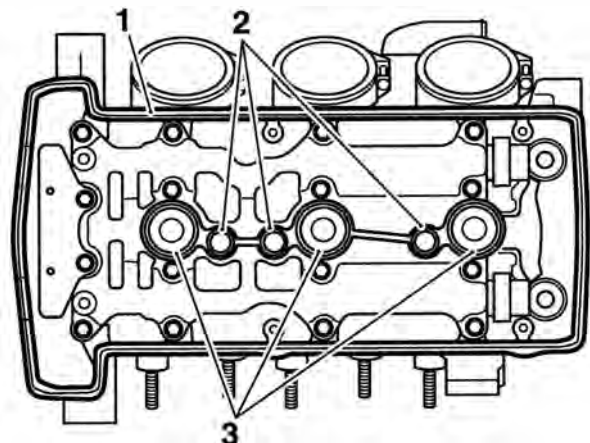

309

### 1. Camshaft cover seal

### 2. Dowels

### 3. Plug tower seals

3. Fit the camshaft cover, ensuring that the gasket remains in the correct position.
4. Lubricate the new camshaft cover screw seals with clean engine oil. Fit the camshaft cover screws and screw seals and tighten until finger tight.
5. Finally, tighten the camshaft cover screws, in the same order as for removal, to **10 Nm**.
6. Refit the throttle bodies, injectors and fuel rail to the cylinder head (see page 10-101).
7. Check the throttle cable adjustment (see page 10-104).

# Cylinder Head

8. Inspect the ignition coils seal for damage and replace if necessary.
9. Fit the ignition coils and reconnect the electrical connectors.

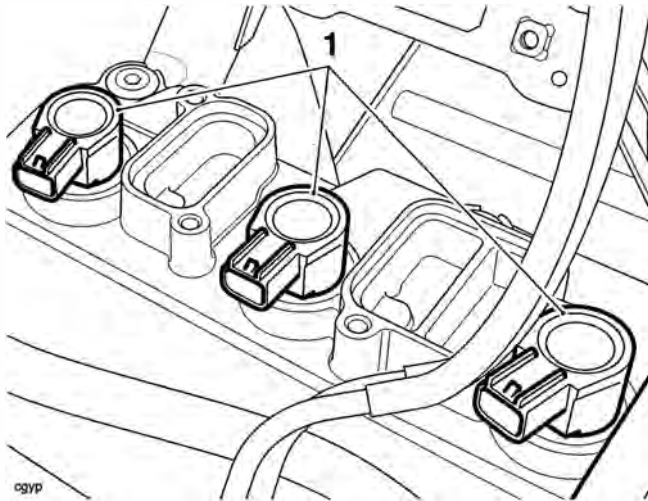

cgyp

## 1. Coils

10. Refit the airbox (see page 10-101).
11. Refit the fuel tank (see page 10-92).
12. Reconnect the battery, positive (red) lead first.
13. Refit the rider's seat (see page 16-13).

## Camshaft Drive Chain Tensioner - all Models

### Removal

1. Remove the camshaft cover (see page 3-6).
2. Remove the right hand crank cover. Discard the gasket.  
Note the positions of the two different bolt lengths. Discard the 35 mm bolts.

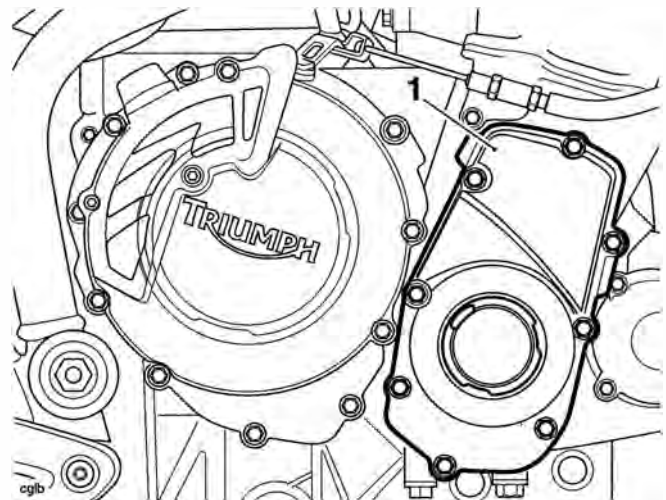

cgib

### 1. Right hand crank cover

3. Rotate the crankshaft clockwise (the normal direction of rotation), using the bolt fitted to the end of the crankshaft. Stop rotation when number 1 cylinder is at top dead centre (TDC), that is when the 'dot' mark on the primary gear aligns with the line on the crankcase.

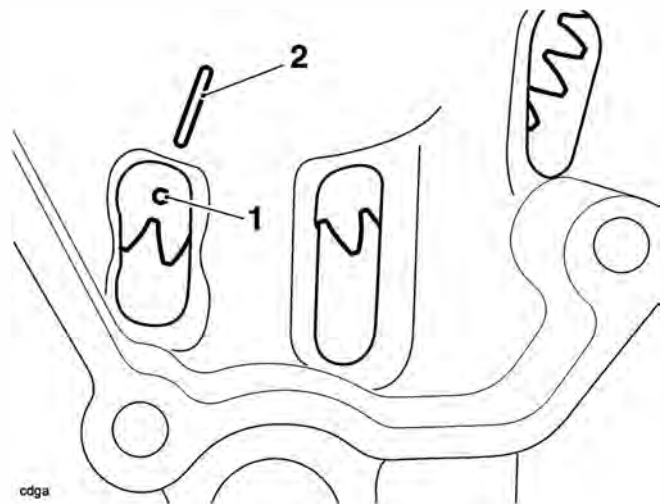

odga

1. 'Dot' mark
2. Marker line

## Note:

- In addition to the 'dot' mark alignment, at TDC, the alignment marks on the camshaft sprockets will point inwards at a point level with the joint face.
- The Tiger 800 and Tiger 800XC camshaft sprockets are common to Daytona 675 and Street Triple models, but use different timing marks. The timing marks for Tiger 800 and Tiger 800 XC are identified by the number 8 next to the timing mark.

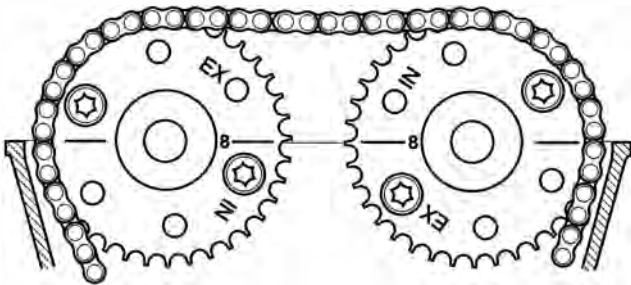

gaaa1

### Camshaft to Cylinder Head Alignment Marks

4. Place a suitable wedge between the camshaft drive chain tensioner blade and crankcase, to hold the camshaft drive chain taut during removal of the tensioner.

## Warning

The hydraulic tensioner is under spring tension. Always wear hand, eye, and face protection when withdrawing the tensioner mounting bolts and take great care to minimise the risk of injury and loss of components.

## Note:

- Note the orientation of the hydraulic tensioner.
5. Evenly release the hydraulic tensioner mounting bolts until the plunger spring tension has been released.
  6. Remove the hydraulic tensioner and discard the O-ring and gasket.

## Installation

1. Check that number 1 cylinder is still at top dead centre (TDC).
2. Ensure that the wedge fitted earlier is still holding the camshaft drive chain tensioner blade in contact with the camshaft drive chain. Check that the camshaft timing marks (identified with a number 8) point inwards and are level with the joint face of the head.
3. To set the hydraulic tensioner onto the first tooth of the ratchet (i.e. minimum extension) carry out the following:

## Note:

- If installing a new hydraulic tensioner, do not release the plunger before fitting.
  - If installing the original hydraulic tensioner, the engine oil must be drained out of the tensioner to enable the plunger to be set onto the first tooth of the ratchet.
4. Hold the resister ring ends together and pull out the plunger.

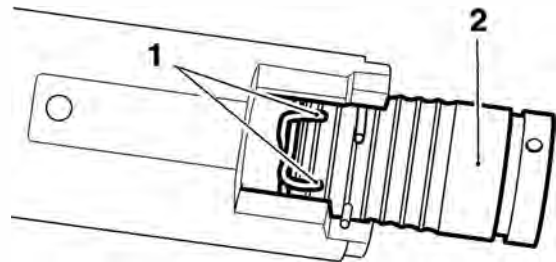

cfel\_2

1. Resister ring ends
2. Plunger

# Cylinder Head

5. Remove the spring.

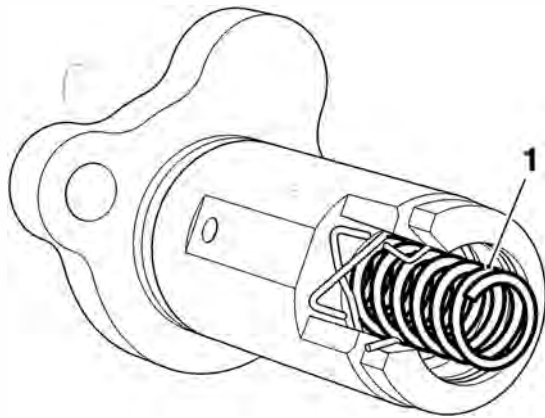

cfhp

## 1. Spring

6. While holding the resister ring in place, pour out the engine oil into a suitable container.
7. Ensure the resister ring is correctly located as shown in the illustration below.

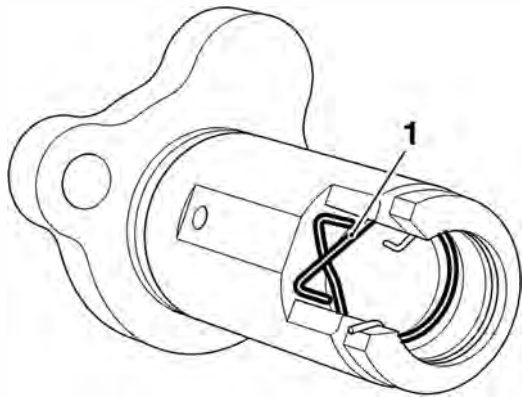

cfho

## 1. Resister ring

8. Refit the spring.

9. Hold the resister ends together and push the plunger through the resister ring until the groove for the snap ring aligns with the snap ring.

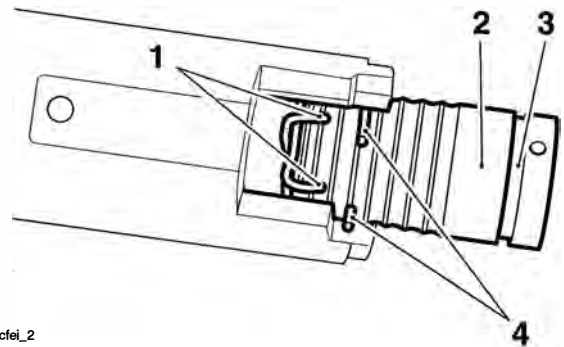

cfel\_2

## 1. Resister ring

## 2. Plunger

## 3. Groove for snap ring

## 4. Snap ring

10. When the groove aligns with the snap ring, release the resister ring and move one end of the snap ring into the groove. Slowly release the plunger to ensure that it is held in place.

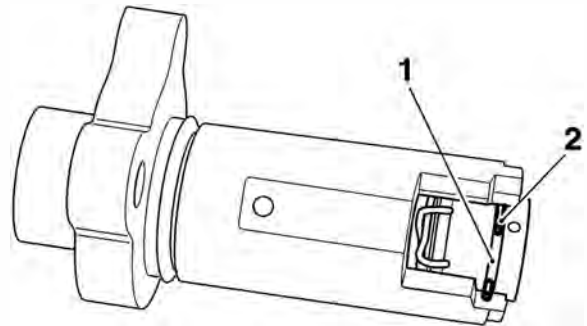

cfelj

## 1. Groove for snap ring

## 2. Snap ring

11. Fit a new O-ring and gasket to the hydraulic tensioner.
12. Fit the tensioner to the cylinder head as noted for removal. Tighten the bolts to **9 Nm**.
13. Remove the camshaft drive chain tensioner blade wedge, taking care not to move or damage the tensioner blade.
14. To release the hydraulic tensioner, rotate the crankshaft 1/4 of a turn anti-clockwise using the bolt fitted to the end of the crankshaft. Then rotate the crankshaft clockwise until the 'dot' mark on the primary gear aligns with the line at the bottom of the cover.

- Check that there is tension in the camshaft drive chain and the timing marks at the camshaft sprockets are correctly aligned.

**Note:**

- After fitting to the engine, the hydraulic tensioner will be empty of engine oil. After starting the engine, the camshaft drive chain and tensioner blade will be noisy until full pressure is felt at the tensioner plunger. This could take up to 5 seconds.

- Check that the tensioner plunger is correctly located in the middle of the camshaft drive chain tensioner blade when viewed from above.
- Rotate the engine through 4 full revolutions, and reset number 1 cylinder to TDC. Ensure that the 'dot' mark on the primary gear aligns with the line at the bottom of the cover.

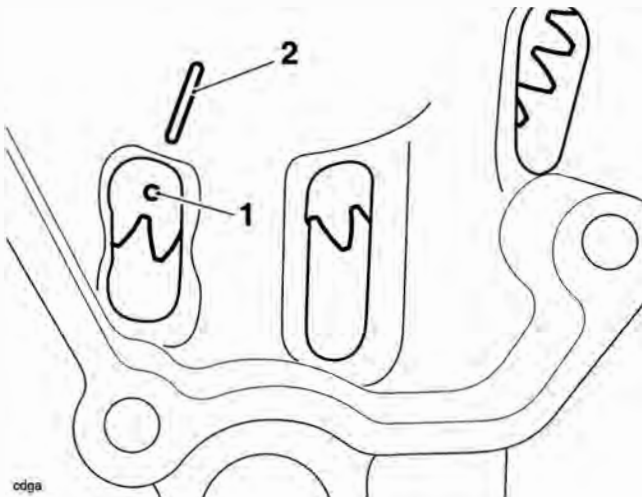

cdga

- 'Dot' mark
- Marker line

- Check that the camshaft timing marks align as illustrated below.

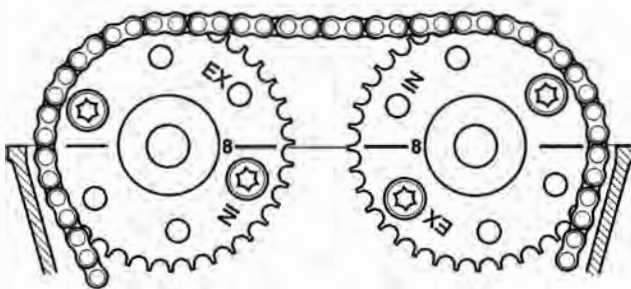

gaaa1

**Camshaft to Cylinder Head Alignment Marks**

- Re-check the tensioner plunger location against the camshaft drive chain tensioner blade.
- Refit the camshaft cover (see page 3-7).
- Fit a new gasket to the right hand crank cover.
- Refit the crank cover.
- Install the bolts, using new 35 mm bolts positioned as noted during removal (the 25 mm bolts may be re-used). Tighten the 25 mm fixings to **8 Nm**, and the 35 mm fixings to **9 Nm**.

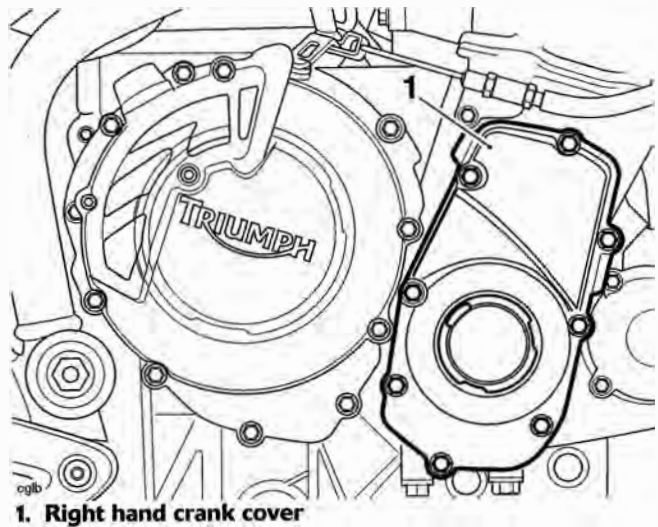

1. Right hand crank cover

# Cylinder Head

## Camshaft Drive Chain Tensioner Blade

### Disassembly

#### Note:

- For the purpose of this instruction, the top of the tensioner blade is where the pad is located.

1. Release the clips and remove the pad.

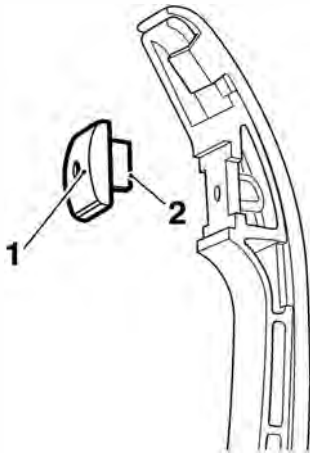

cfee

#### 1. Pad

#### 2. Clip (one side shown)

2. Detach the top hook from the tensioner blade.

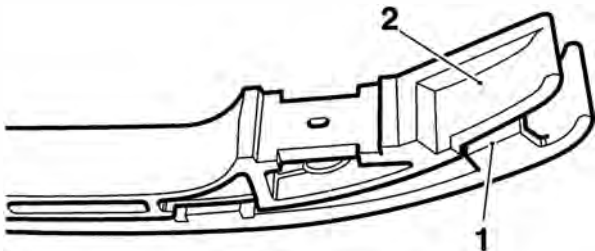

cfef

#### 1. Top hook

#### 2. Tensioner blade

3. Release the three side locating devices.

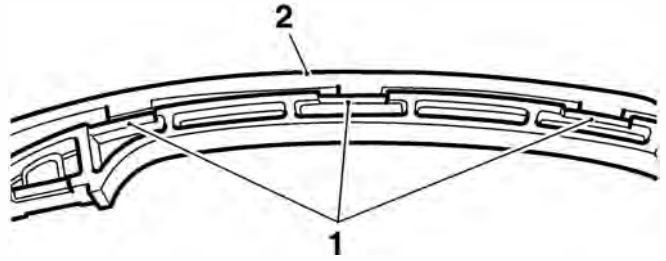

cfeg

#### 1. Locating devices

#### 2. Facing blade

4. Release the three hooks and remove the facing blade.

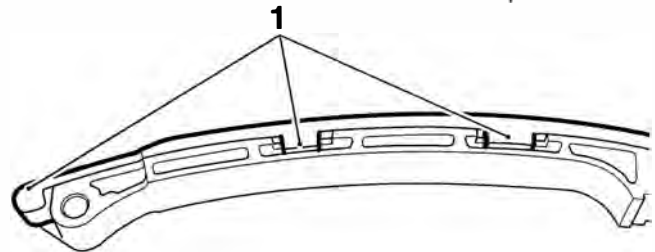

cfeh

#### 1. Hooks

### Assembly

1. Assembly is the reverse of disassembly.

## Camshafts

### Removal

1. Remove the camshaft drive chain tensioner (see page 3-8).

#### Note:

- It is not necessary to remove the camshaft drive chain completely.
  - Each camshaft and sprocket is removed as an assembly.
  - Before commencing work, ensure the crankshaft 'dot' mark is in alignment with the line in the crankcase.
2. Note the orientation of the camshaft ladder in relation to the head.
  3. Progressively release the bolts securing the camshaft ladder to the head in the sequence shown below.

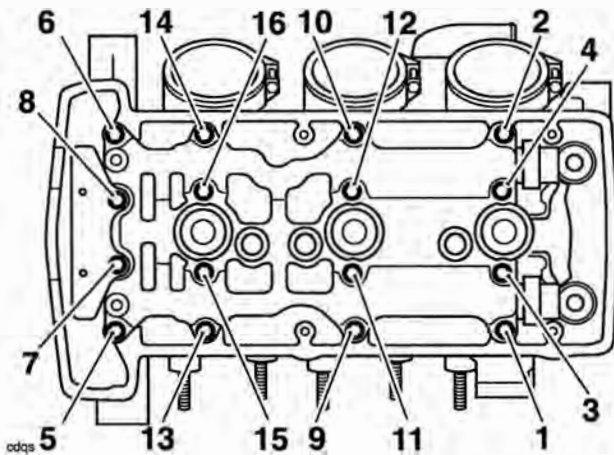

#### Camshaft Ladder Bolt Release Sequence

4. Remove the camshaft ladder and top pad, and collect the dowels (if loose) and spark plug tower O-rings.
5. Lift the camshaft drive chain from the exhaust camshaft sprocket and remove the exhaust camshaft.

6. Repeat the procedure for the inlet camshaft.

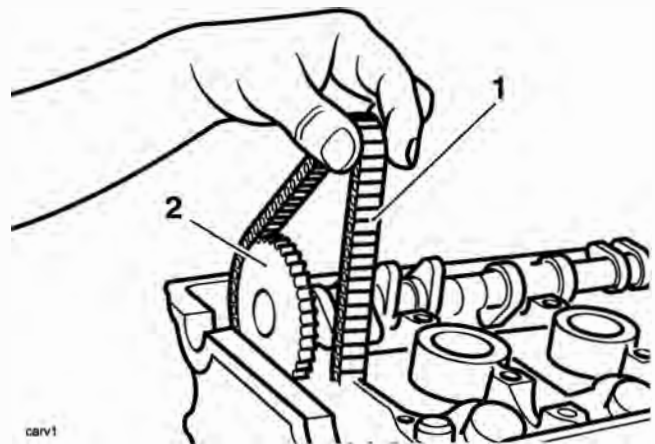

1. Camshaft drive chain
2. Inlet camshaft

#### Note:

- The inlet and exhaust camshafts are different. They can be identified by a raised feature in the centre of the exhaust camshaft, which is machined off on the inlet camshaft. The camshafts can be further identified a letter 'I' for inlet or 'E' for exhaust stamped on the end of the sprocket boss.

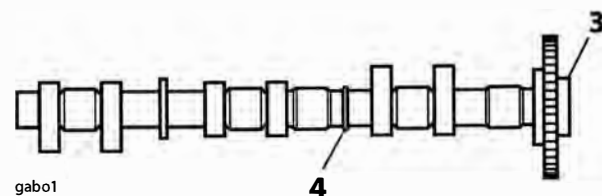
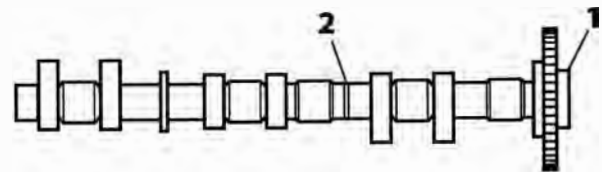

1. Inlet camshaft
2. Machined section
3. Exhaust camshaft
4. Raised section

# Cylinder Head

## Camshaft and Bearing Cap Inspection

1. Inspect the camshaft sprockets for damaged and worn teeth. Replace as necessary.

### **Caution**

The same sprocket is used for both inlet and exhaust camshafts. To attach the sprocket to the different camshafts, different bolt holes are used.

Never fit a camshaft sprocket to a camshaft using incorrectly identified bolt holes. Severe engine damage will result from incorrect attachment.

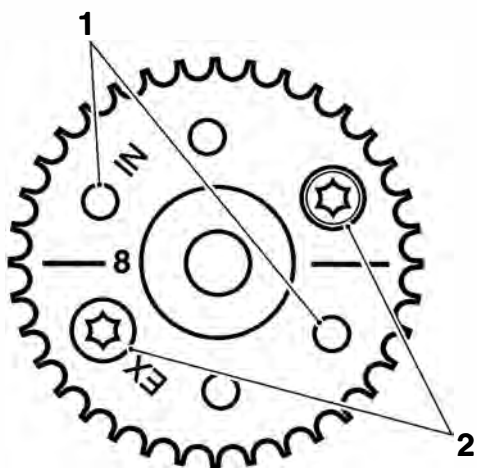

#### 1. Inlet camshaft bolt holes

#### 2. Exhaust camshaft bolt holes

2. Measure the camshaft journals with a micrometer. If any journal is outside the specified tolerance, replace the camshaft.

### Standard Journal Diameters

Standard:	23.940 - 23.960 mm
-----------	--------------------

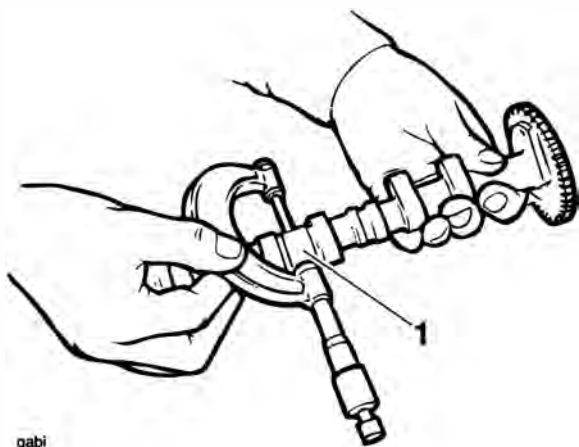

gabi

#### 1. Standard journal

3. Examine the camshaft and camshaft ladder for excessive wear and damage.

4. Check the journal-to-head clearances, using 'Plastigage' (Triumph part number 3880150-T0301) as follows:
  - a) Ensuring that the camshaft sprocket alignment marking is located as for removal, assemble one camshaft to the head and progressively tighten the camshaft ladder in the sequence shown overleaf (see page 3-15).
  - b) Remove the camshaft ladder using the bolt release sequence given earlier. Wipe the exposed areas of both the camshaft journal and a single cap area of the ladder.
  - c) Apply a thin smear of grease to the journal and a small quantity of silicone release agent to the camshaft cap area of the ladder.
  - d) Size a length of the Plastigage to fit across the camshaft journal. Fit the Plastigage to the camshaft journal using the grease to hold the strip in place.
  - e) Refit the camshaft ladder then evenly and progressively tighten all the camshaft ladder bolts in the correct sequence (see camshaft installation).
  - f) Release the bolts and remove the camshaft ladder. Using the gauge provided with the Plastigage kit, measure the width of the now compressed Plastigage.

#### Note:

- The camshaft ladder is unique to each cylinder head and is, therefore, not available individually. If the camshaft ladder is worn or damaged, the complete cylinder head must be replaced.



#### Measuring the Compressed Plastigage.

5. Calculate the journal clearance using the Plastigage chart supplied with the Plastigage kit.



## Camshaft journal clearance

Standard:	0.040 - 0.081 mm
Service limit:	0.170 mm

- If the clearance measured is within the specified tolerance, remove the ladder and clean off all traces of Plastigage. Assemble the camshafts (see page 3-15).

### Note:

- If the measured clearance is outside the tolerance, and the camshaft journals are within tolerance, the cylinder head must be replaced.

## Caution

Although Plastigage is oil soluble, all traces of the material must be removed to prevent blockage of the oil drillings and resultant engine damage.

## Installation

- Thoroughly clean the camshafts and journals. Inspect the ends of the camshafts for correct fitment of the sealing plugs. Lubricate the camshafts with clean engine oil before fitting to the head.
- Locate each camshaft to the head ensuring the camshafts are correctly identified (inlet and exhaust) and are also correctly located over their respective valve banks.
- Working on one camshaft at a time, locate the camshaft drive chain over the camshaft sprocket. Position the camshaft in the same position as for removal before attempting to fit the ladder (that is, with the timing marks on the camshaft sprockets level and pointing inwards, and with the 'dot' mark on the primary gear in alignment with the line on the crankcase).

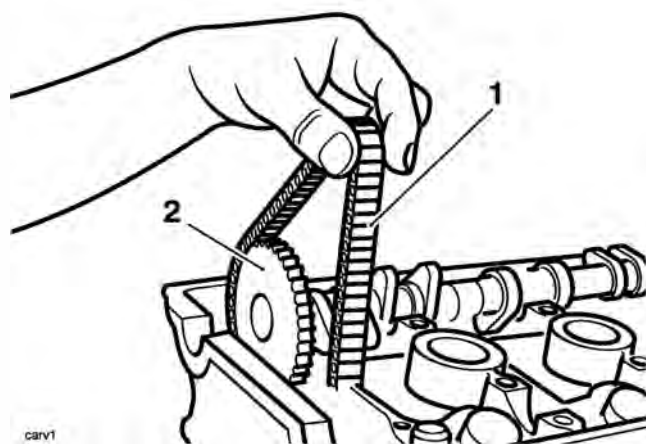

- Camshaft drive chain
- Inlet camshaft

- Repeat the procedure for the other camshaft.

## Caution

If the camshafts and ladder are fitted without first aligning the timing marks on both the crankshaft and camshaft sprockets, the inlet and exhaust valves will contact each other causing damage to both the head and the valves.

- Lubricate the camshaft bearing areas of the camshaft ladder with a 50/50 solution of engine oil and molybdenum disulphide grease.
- Assemble the dowels, camshaft ladder and top pad in the same location and orientation as prior to removal.

### Note:

- The bolts for the camshaft cap ladder are tightened in stages.

### Stage 1

- Lubricate the threads of the camshaft cap ladder bolts with clean engine oil, then fit and evenly tighten the bolts to **5 Nm**, in the sequence shown below.

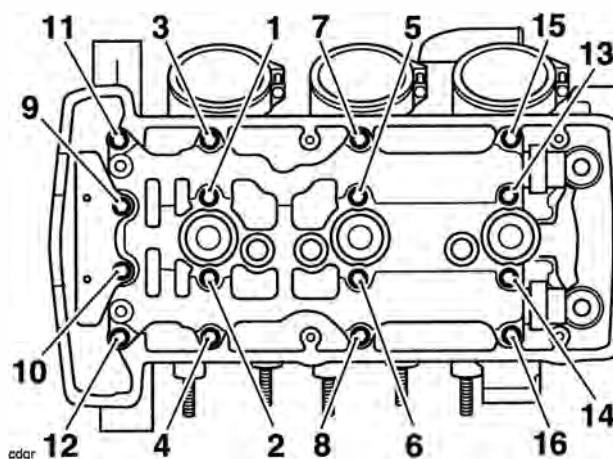

Camshaft Cap Ladder Bolt Tightening Sequence

# Cylinder Head

## Stage 2

- In the sequence shown above, tighten the bolts to **10 Nm**.
- Before fitting the camshaft drive chain tensioner, ensure that each camshaft rotates freely using service tool T3880102. Do not rotate either camshaft by more than 5°.

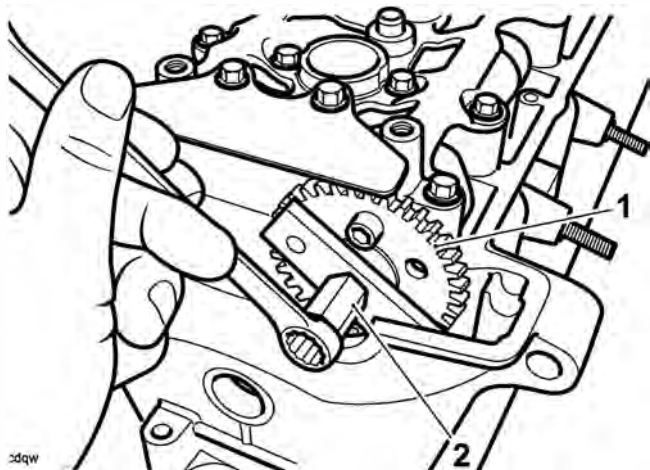

- Exhaust camshaft
- Tool T3880102



### Caution

If any components have been renewed, the valve clearances must be checked and adjusted. Running with incorrectly adjusted valve clearances may cause excess engine noise, rough running and engine damage.

- Refit the camshaft drive chain tensioner (see page 3-9).
- Rotate the engine through 4 full revolutions, and reset number 1 cylinder to TDC. Ensure that the 'dot' mark on the primary gear aligns with the line on the crankcase.

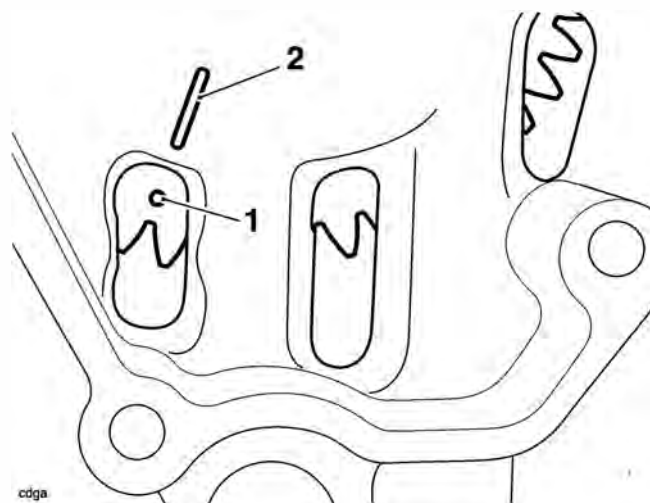

- 'Dot' mark
- Marker line

### Note:

- In addition to the 'dot' mark alignment, at TDC, the alignment marks on the camshaft sprockets will point inwards at a point level with the joint face.
- Check that the camshaft timing marks align as illustrated below. Rectify any misalignment before proceeding.

### Note:

- The Tiger 800 and Tiger 800XC camshaft sprockets are common to Daytona 675 and Street Triple models, but use different timing marks. The timing marks for Tiger 800 and Tiger 800 XC are identified by the number 8 next to the timing mark.

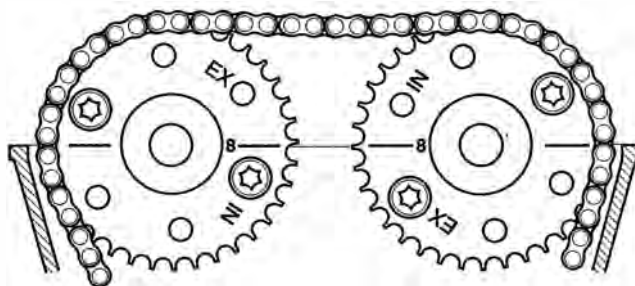

gaaa1

### Camshaft to Cylinder Head Alignment Marks

- Check the valve clearances. Adjust as necessary (see page 3-18).

## Valve Clearances

Camshaft, valve, valve shim and valve seat wear affects the valve clearances. The effect of this wear is to change the gap between the camshaft and tappet bucket, causing engine noise and improper running. If the valve clearances become too small, permanent damage to the valve and valve seat will take place. If the valve clearance becomes too great, the engine will become noisy and will not run correctly.

### Valve Clearance Measurement

**Note:**

- **Valve clearance measurement must be carried out with the engine cold.**

1. Remove the camshaft cover (see page 3-6).
2. Remove the spark plugs to reduce compression resistance when turning the engine.
3. Select a high gear and, using the rear wheel, turn the engine until a pair of camshaft lobes are positioned pointing away from the valves.
4. Using feeler gauges, measure and record the clearances for this pair of valves only.
5. Repeat the process until the valve clearances for all valves have been checked.

**Note:**

- **If the measurement does not fall within the specified range, adjustment must be made.**
- **The correct valve clearances are in the range given below:**

Inlet:	0.10 - 0.20 mm
Exhaust:	0.325 - 0.375 mm

 **Caution**

If the valve clearances are not checked and corrected, wear could cause the valves to remain partly open, which lowers performance, burns the valves and valve seats and may cause serious engine damage.

6. Record the measured valve clearances on a chart similar to the example shown.

### Typical Valve Clearance Chart

Inlet Valve No.	Gap Measured
1	as measured (mm)
2	as measured (mm)
3	as measured (mm)
4	as measured (mm)
5	as measured (mm)
6	as measured (mm)
Exhaust Valve No.	Gap Measured
1	as measured (mm)
2	as measured (mm)
3	as measured (mm)
4	as measured (mm)
5	as measured (mm)
6	as measured (mm)

# Cylinder Head

## Valve Clearance Adjustment

### Note:

- **To adjust the valve clearances the camshafts must be removed. Follow the camshaft removal procedure.**

1. Remove the camshafts (see page 3-13).
2. Remove the tappet bucket from the cylinder head.
3. Remove the shim from the valve head.

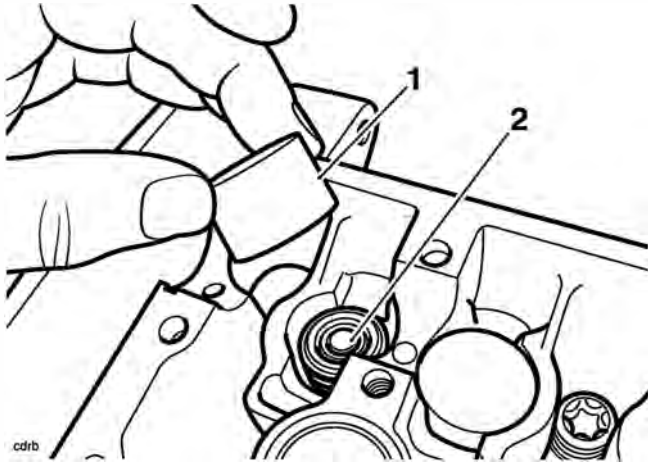

1. Tappet bucket
2. Shim

### Note:

- **The shim may withdraw with the tappet bucket.**

4. Measure the original shim, using a micrometer and select the appropriate new shim as required.

Clearance too small:

- **Fit a thinner shim.**

Clearance too large:

- **Fit a thicker shim.**

### Note:

- **Shims are available ranging from 1.70 mm to 3.00 mm in increments of 0.025 mm.**

5. Fit the new shim to the valve head.
6. Lubricate the tappet bucket(s) with a 50/50 solution of engine oil and molybdenum disulphide grease.
7. Refit the tappet bucket.
8. Refit the camshafts (see page 3-15).
9. Re-check all valve clearances.
10. Repeat the procedure if the valves require further adjustment.

## Camshaft Drive Chain

### Removal

1. Remove the camshafts (see page 3-13).
2. Remove the bolt from the centre of the camshaft drive chain housing in the cylinder head.

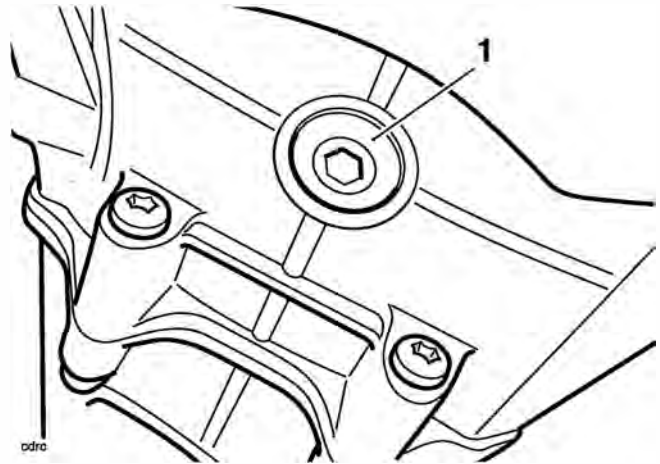

### 1. Centre bolt

3. Remove the fixing and raise the front camshaft drive chain rubbing blade and detach the camshaft drive chain from the crankshaft gear.
4. The camshaft drive chain is removed from inside the head-space.

## Inspection

Visual in-situ checks can also be made as follows:

1. Check for significant discolouration of the chain plates indicating excessive heat build-up.
2. Examine all pins for signs of rotation.
3. Check for cracking or deep scratching of the chain plates.
4. Check for severe wear of the inner plates as indicated in the diagram below.

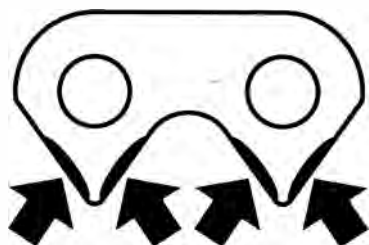

ccrv

For a more thorough check, proceed as follows:

1. Remove the chain from the engine.
2. Suspend the chain from a pin or hook with a 13kg weight attached at the lower end.

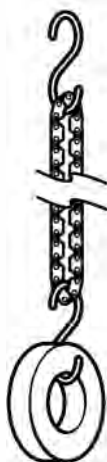

cajs

3. Measure across 23 links as shown in the diagram below. If the chain is within limits, the measurement should be no longer than 149.48 mm. Measurements beyond 149.48 mm indicate that the chain must be replaced.

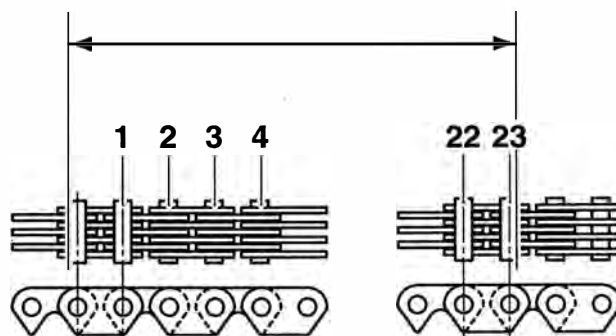

cajt

4. Check for severe wear of the inner surface of the outer plates at the side-contact points with the sprocket teeth.

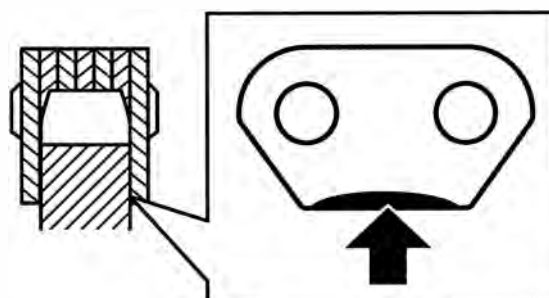

ccru

5. Check for signs of stiffness or kinking.

# Cylinder Head

6. Check for severe wear of the plates in the area shown below.

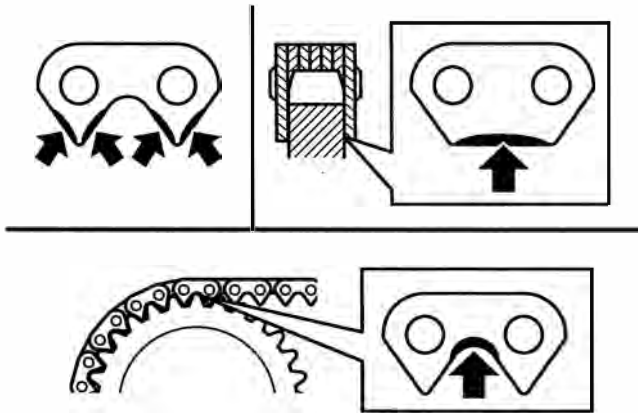

caju

If any of these symptoms are evident, the camshaft drive chain must be replaced.

## Installation

1. Fit the camshaft drive chain and locate the lower end around the crankshaft gear.
2. Incorporating a new seal, refit the bolt to the centre of the camshaft drive chain housing in the cylinder head, tightening to **12 Nm**.
3. Refit the camshafts (see page 3-15).

# Cylinder Head

## Removal

### Note:

- **Removal of the cylinder head is not possible with the engine in the frame.**

1. Remove the engine from the frame (see page 9-3).
2. Remove the camshafts (see page 3-13).
3. Remove the camshaft drive chain (see page 3-18).
4. Remove the camshaft drive chain tensioner blades.
5. Note the position of all tappet buckets and shims such that they can be refitted in the same positions. Remove all the tappet buckets and shims.

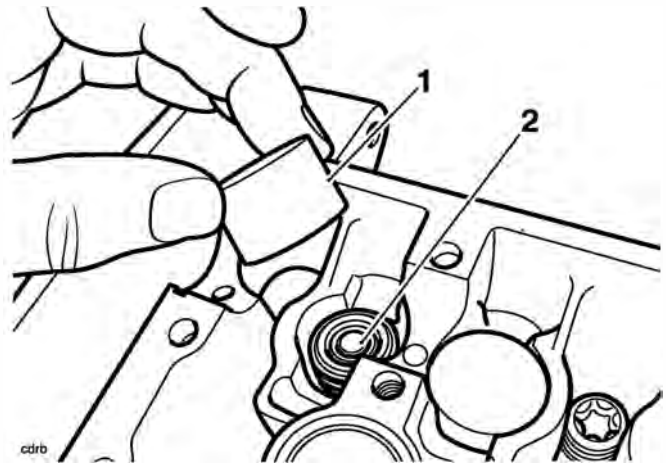

1. Tappet bucket
2. Shim

### Note:

- **To prevent the tappet buckets and shims from becoming mixed, place the shim and tappet together in a marked container. The components must be refitted in their original positions.**
6. Disconnect the coolant bypass hose from the rear of the cylinder head.

- Release the screws securing the outside of the cylinder head to the upper crankcase.

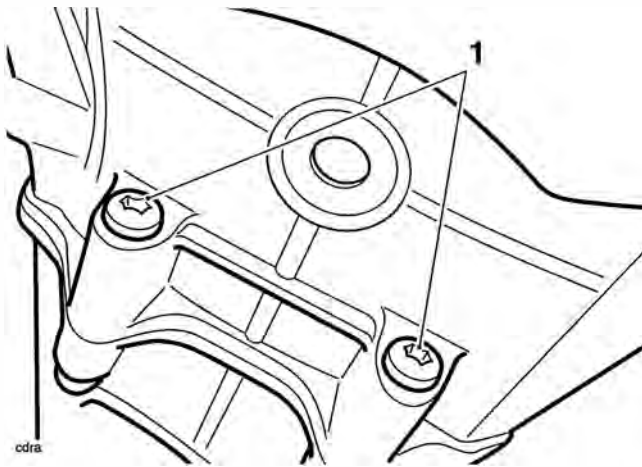

### 1. Cylinder head to upper crankcase screws

- Progressively release the cylinder head bolts in the order shown below.

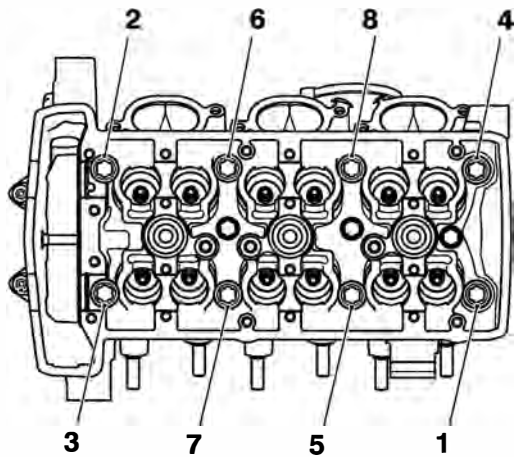

### Cylinder Head Bolt Release Sequence

- Lightly tap the cylinder head with a rubber mallet to break the seal of the gasket.
- Remove the cylinder head. Discard the cylinder head bolts and gasket.

### Inspection

- Thoroughly clean the surface of the head and check for damage and pitting of the combustion chambers.
- Using a straight edge, check the cylinder head gasket face for warp which could lead to gasket failure. Replace the head if warped.

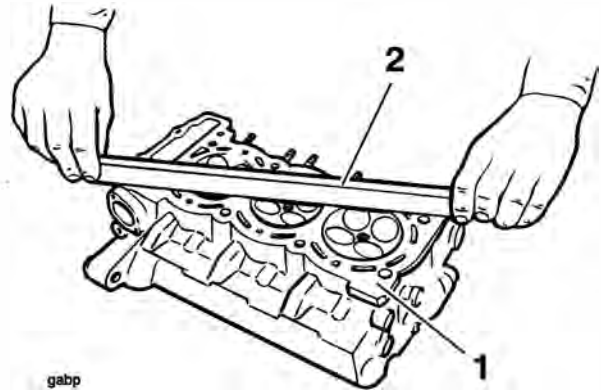

### 1. Cylinder head gasket face

### 2. Straight edge

- Check the camshaft drive chain tensioner blades. Renew if worn or damaged.

# Cylinder Head

## Installation

1. Thoroughly clean the upper faces of the crankcase, taking care not to damage the mating surfaces.
2. Fit a new cylinder head gasket ensuring that the head to crankcase location dowels are correctly in place.

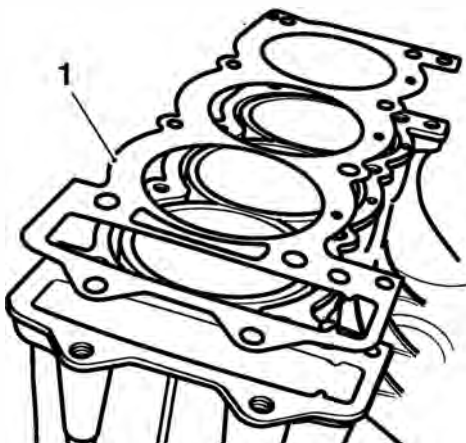

### 1. Cylinder head gasket

3. Ensure that the cylinder head face is completely clean.
4. Carefully lower the cylinder head over the camshaft drive chain and locate the head onto the dowels.



## Caution

Using the correct procedure to fit and tighten the cylinder head bolts will ensure the long term reliability of the cylinder head gasket.

Clean each new bolt, paying particular attention to the threads and under-bolt-head areas. If any of the threads or bolt-head areas are damaged, replace the bolt(s).

Tighten the bolts using the three-stage procedure given below.

Failure to observe these important items may lead to engine damage through a damaged head gasket.

5. Fit new bolts and washers to the head and tighten until finger tight.

6. The cylinder head bolts must be tightened in the following sequence:

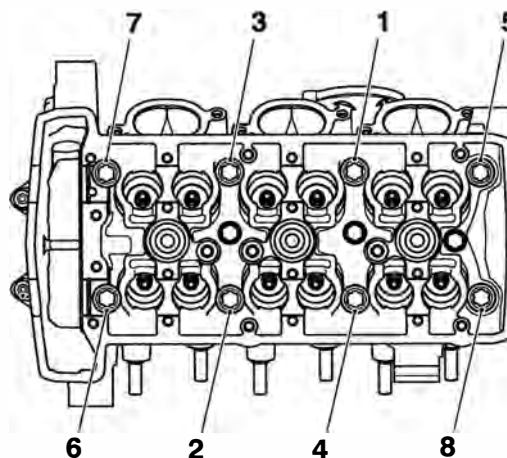

### Cylinder Head Bolt Tightening Sequence

7. The head bolts are finally tightened in three stages, all using the above sequence. This is to ensure that the cylinder head gasket seals correctly to the head and crankcase. The three stages are as follows:

#### Note:

- For stages A and B of the head bolt tightening operation, a torque wrench of known, accurate calibration must be used.

**A:** Tighten the head bolts, in the sequence shown above, to 15 Nm.

**B:** Tighten the head bolts in the sequence shown on the previous page, to 20 Nm.

- For the final torque operation, Stage C, (see below) which is carried out in the sequence shown on the previous page, a 'torque turn' method is used. The bolts must be turned through 120° to reach the final setting. To accurately gauge the 120° turn, use service tool 3880105-T0301 as follows:



- C:** Fit the tool between the Torx socket and the drive handle and locate the Torx drive to the head bolt. Pick an increment point on the torque turn gauge which aligns with a suitable reference point on the head. Tighten the bolts until 12 of the 10° (I.E. 120°) gauge increments have rotated past the chosen point on the head.

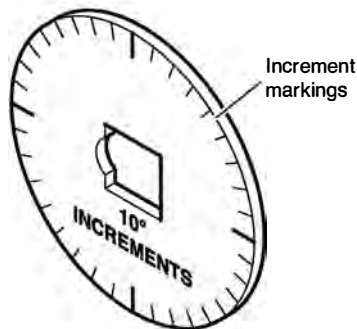

cbxt

**Tool T3880105-T0301**

6. Fit the screws securing the side of the cylinder head to the crankcase and tighten to **10 Nm**.

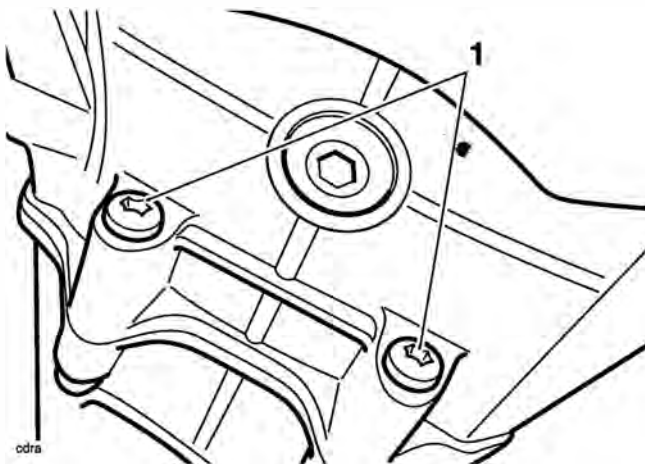

cdra

**1. Cylinder head to upper crankcase screws**

7. Install the camshaft drive chain tensioner blades. Install a new bolt to the front tensioner blade and tighten to **9 Nm**.
8. Clean and lubricate the tappet buckets with a 50/50 solution of engine oil and molybdenum disulphide grease and refit the buckets and shims in the same locations from which they were removed.
9. Refit the camshaft drive chain (see page 3-20).
10. Refit the camshafts (see page 3-15).
11. Install the engine to the frame (see page 9-5).

## Valves and Valve Stem Seals

### Removal from the Cylinder Head

1. Remove each valve from the head using a valve spring compressor. The compressor must act on the top cup to allow removal of the valve collets.

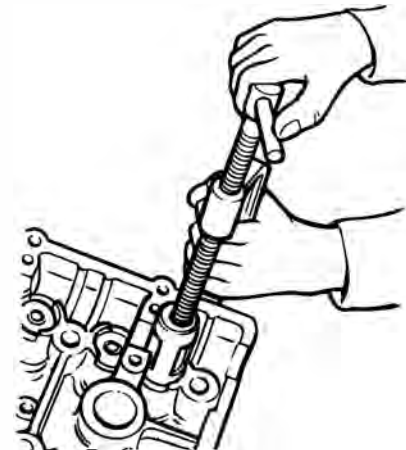

gadh

### Valve removal

2. Once the collets are released, remove the following items:
  - valve spring retainer
  - valve spring
  - valve spring base
  - valve stem oil seal
  - valve (de-burr before removal)

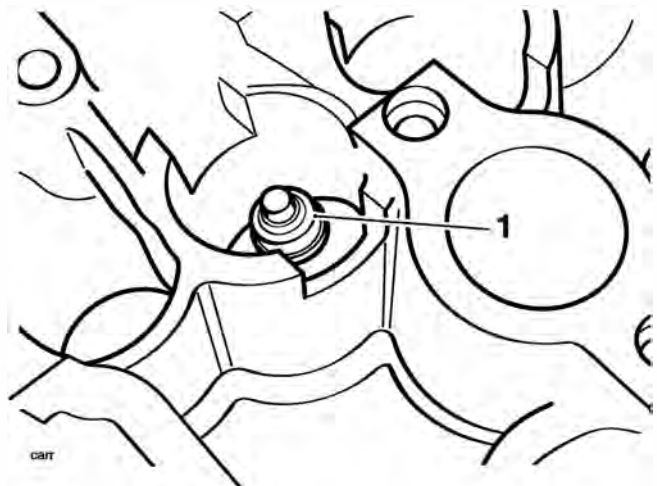

carr

**1. Valve stem seal**

# Cylinder Head

## Note:

- Ensure inlet and exhaust valve components do not become mixed.

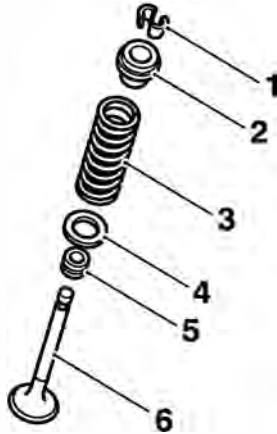

1. Collets
2. Valve spring retainer
3. Valve spring
4. Valve spring base
5. Valve stem oil seal
6. Valve

## Installation

1. Lubricate the valve stems with a 50/50 solution of engine oil and molybdenum disulphide grease.
2. Install the valve into the valve guide and refit the spring base to the valve spring recess in the head.
3. Fit the valve stem seal over the valve stem and, using a suitable tool, press down fully until the seal is correctly seated over the valve guide.

## Note:

- During fitment of the valve stem seal, two distinctly different degrees of resistance will be noted when the seal is correctly fitted.
- Firstly, press the seal down the valve stem until the lower side of the seal comes into contact with the valve guide. Greater resistance is felt at this contact point and further gentle pressure is then required to locate the seal over the top end of the valve guide.
- On application of this pressure, the seal can be felt to positively locate over the top face of the valve guide. Once correctly positioned, the seal cannot be pushed down any further.



## Caution

Incorrect fitment of the valve stem oil seals could lead to high oil consumption and blue smoke emissions from the exhaust system. Do not use excessive force in fitting the seal as this may break the seal ring.

4. Install the valve spring over the valve stem. Ensure the close wound, colour coded ends of the springs are fitted downwards (towards the piston).
5. Fit the valve spring retainer.
6. Compress the valve spring ensuring that the spring is compressed squarely to prevent damage to the valve stem and cylinder head.
7. Fit the valve collets ensuring correct collet location in the spring retainer and valve as the spring compressor is released.



## Caution

Always check for correct location of the valve collets during and after assembly. If not fitted correctly, the collets may become dislodged when the engine is running allowing the valves to contact the pistons. Any such valve to piston contact will cause severe engine damage.

## Valve to Valve Guide Clearance

If the valve guides are worn beyond the service limit given below, the cylinder head must be replaced.

## Valve Stem to Guide Clearance

Inlet:	0.010 - 0.040 mm
Service limit	0.078 mm
Exhaust:	0.030 - 0.060 mm
Service limit	0.098 mm

## Valve Guides

If a valve guide is found to be worn beyond the service limit, the complete cylinder head must be renewed.

## Valve Face Inspection

Remove any carbon build-up from the valve head area. Examine the valve seat face, checking in particular for signs of cracking or pitting.

This page intentionally left blank

# 4 Clutch

## Table of Contents

Exploded View - Clutch Cover.....	4.2
Exploded View - Clutch Assembly .....	4.3
Exploded View - Clutch Controls .....	4.4
Clutch Cable .....	4.5
Removal .....	4.5
Inspection .....	4.5
Assembly.....	4.5
Clutch .....	4.6
Disassembly .....	4.6
Clutch Plate Inspection .....	4.7
Friction Plate Thickness .....	4.7
Steel Plate Bend/warp .....	4.8
Clutch Pack Height .....	4.8
Assembly.....	4.10

# Clutch

## Exploded View - Clutch Cover

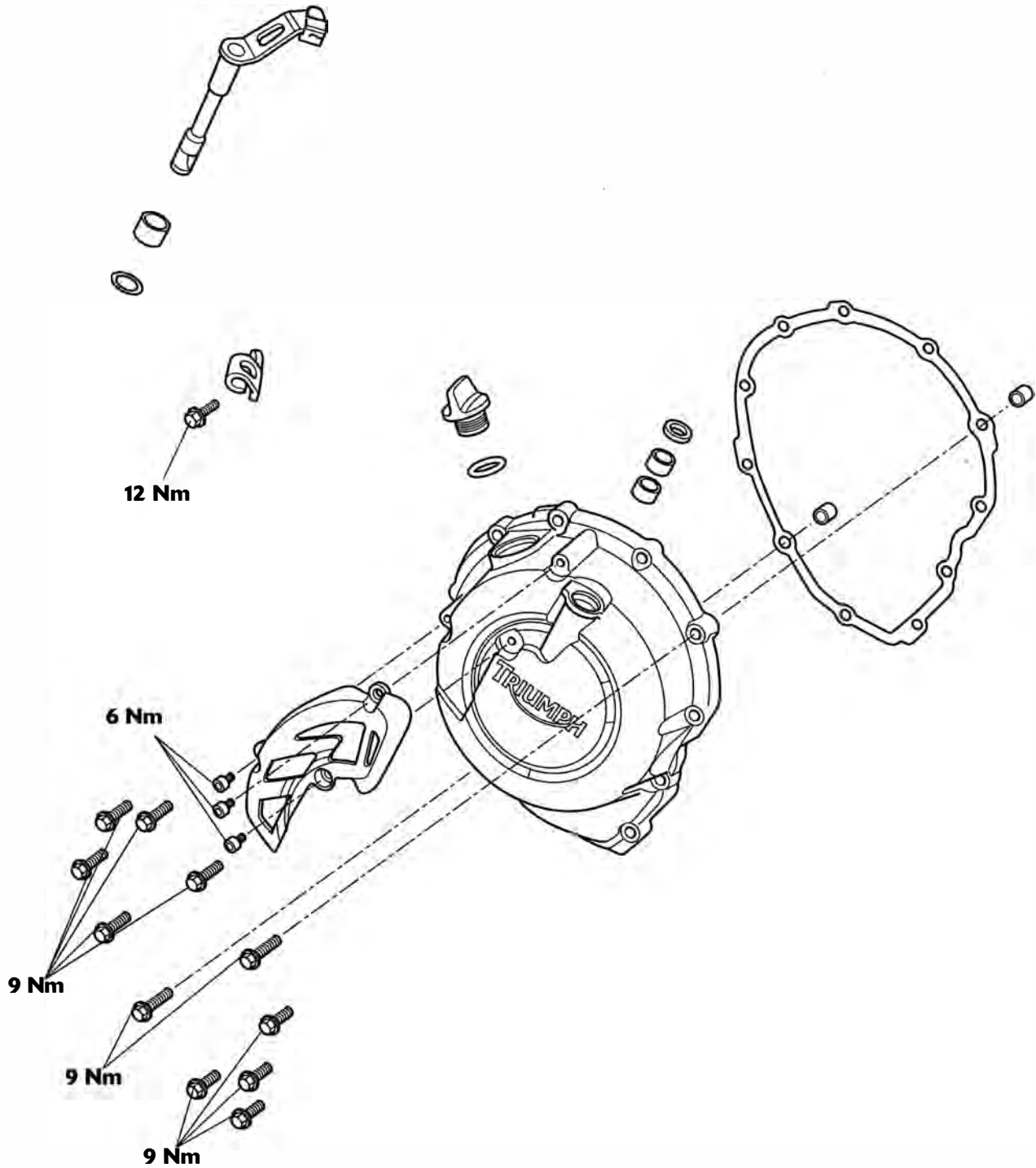

Exploded View - Clutch Assembly

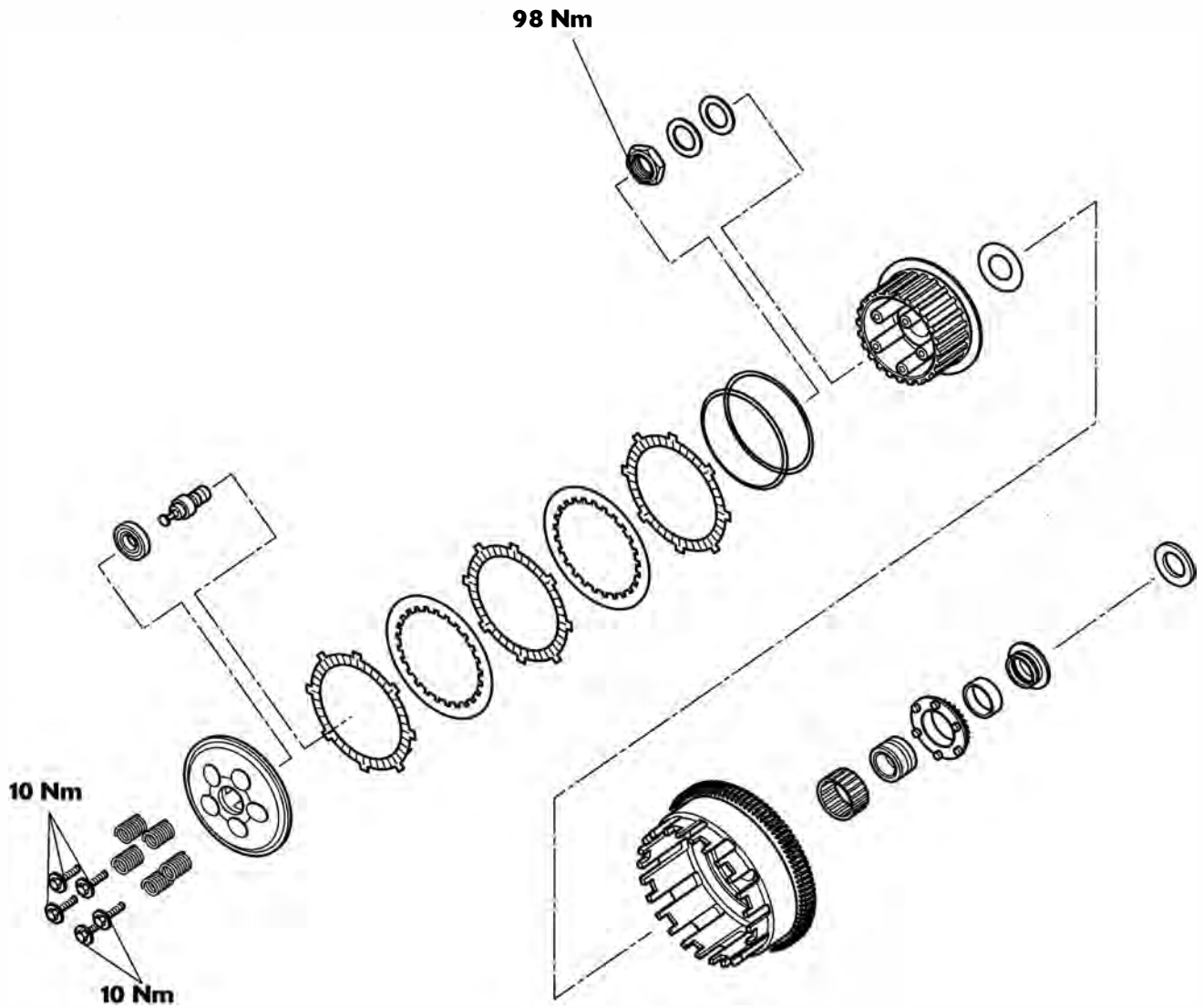

# Clutch

## Exploded View - Clutch Controls

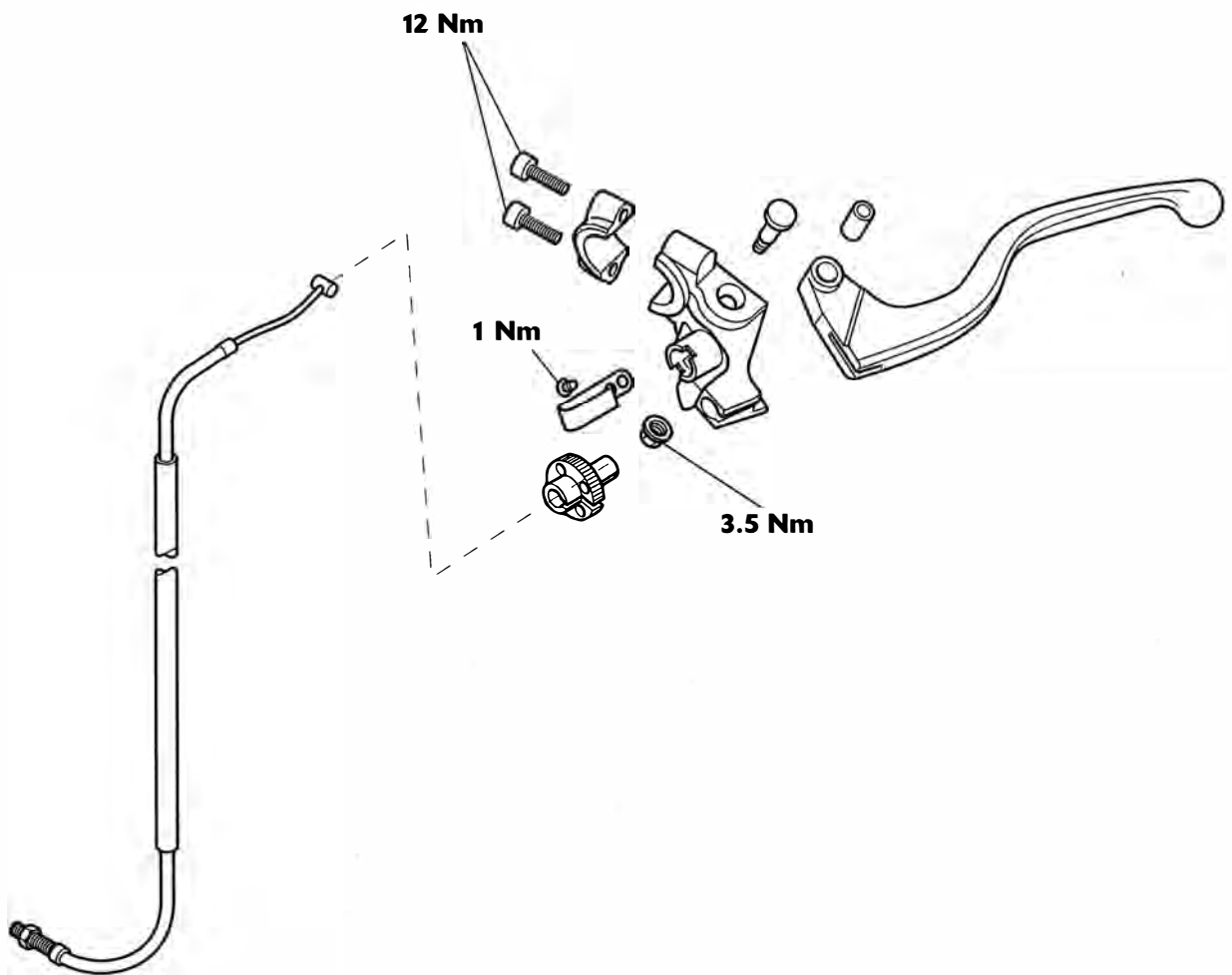



## Clutch Cable

### Removal

1. Remove the rider's seat (see page 16-13).
2. Disconnect the battery, negative (black) lead first.
3. Slacken the cable locknut and release the adjuster at the clutch cover end to give maximum play in the cable.
4. Release the clutch cable from the actuating arm by pushing the inner cable nipple through the arm and sliding the cable out of the slot. Detach the cable from the bracket.

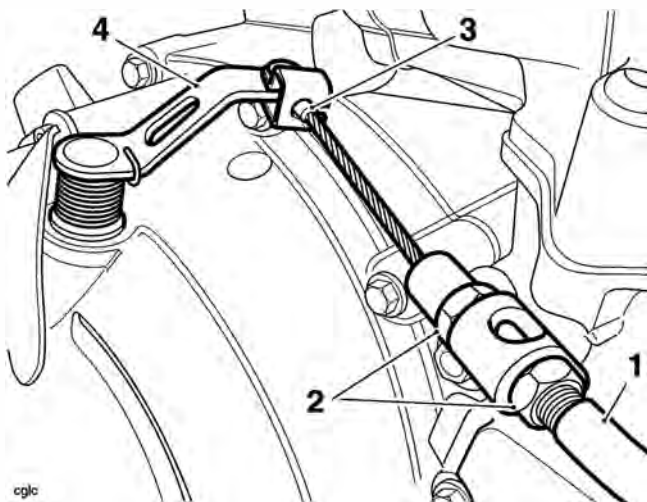

1. Clutch cable
2. Adjuster
3. Inner cable nipple
4. Actuating arm

5. Align the cable adjuster and lever bracket slots.
6. Pull in the clutch lever and turn the inner cable, anti-clockwise through the slots in the adjuster, until the cable can be detached from the lever by pushing downwards.

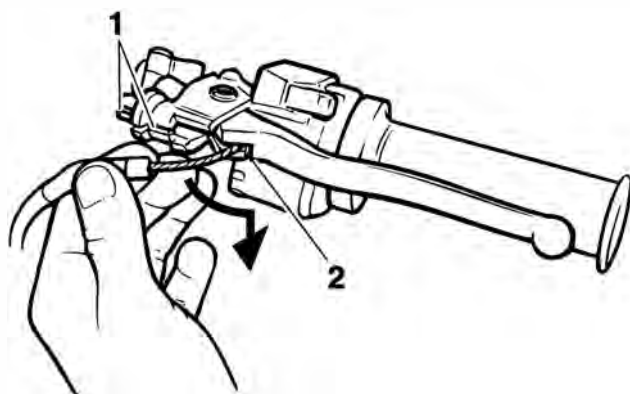

1. Cable adjuster/lever bracket slots
2. Cable release point

7. Remove the cable from the motorcycle noting the cable routing.

### Inspection

1. Check the inner cable for free movement through the outer cable.
2. Examine the inner cable for frayed strands.
3. Examine the two inner cable nipples for signs of looseness and damage. Replace the cable if necessary.

### Assembly

1. Position the cable to the motorcycle using the same routing as noted during removal.
2. Attach the inner cable to the clutch lever and actuating arm using a reversal of the removal process.
3. Refit the outer cable to the adjuster bracket at the clutch end.

### Note:

- **Ensure that the two adjuster nuts are positioned one either side of the bracket.**
4. Set the lever adjuster to a point where an equal adjustment is possible in both directions.
  5. Set the adjuster at the clutch end to give a preliminary setting of 2-3 mm of free play as measured at the lever. Tighten the locknuts.
  6. Operate the clutch lever several times and recheck the amount of free-play present.
  7. Set the final adjustment of the cable to give 2-3 mm of free-play at the lever by turning the adjuster nut and locknut at the lever end.

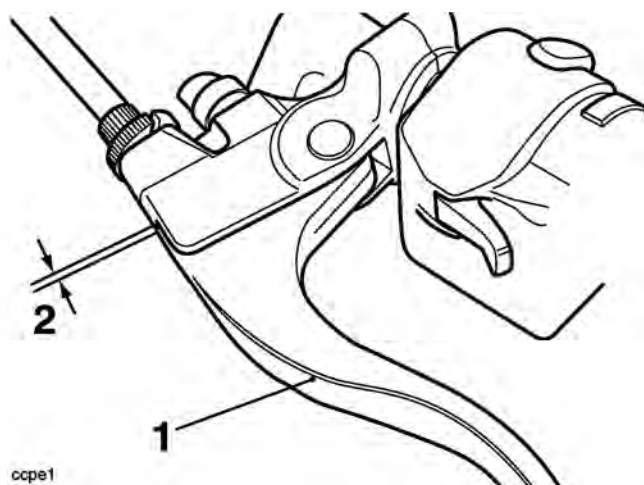

1. Clutch lever
  2. Correct setting, 2-3 mm
8. Reconnect the battery, positive (red) lead first.
  9. Refit the rider's seat (see page 16-13).

# Clutch

## Clutch

### Disassembly

1. Remove the rider's seat (see page 16-13).
2. Disconnect the battery, negative (black) lead first.
3. Release the clutch cable from the actuating arm (see page 4-5).
4. Remove the clutch cover. Discard the clutch cover gasket.

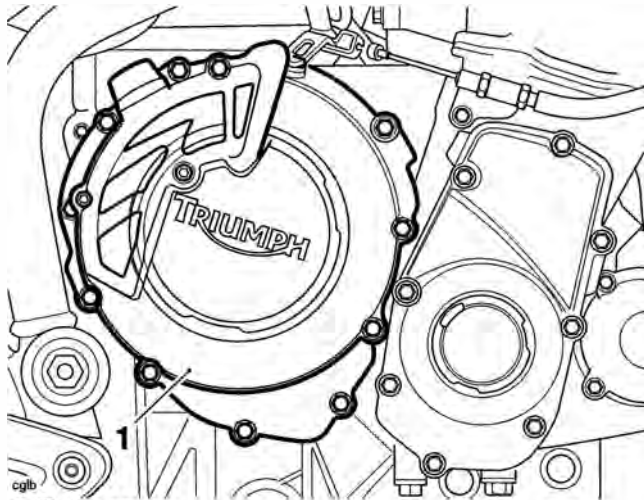

**1. Clutch cover**

5. Undo the bolts and remove the springs and clutch pressure plate.
6. Remove the clutch pull-rod.

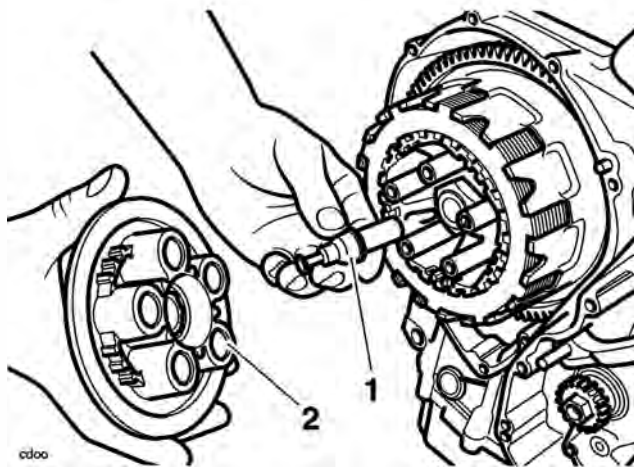

- 1. Clutch pull-rod**
- 2. Clutch pressure plate**

7. Remove the clutch friction plates and steel plates together with the anti-judder spring and anti-judder seat washer.

### Note:

- Record the orientation of all components as they are removed. The plates must be assembled in the same order.

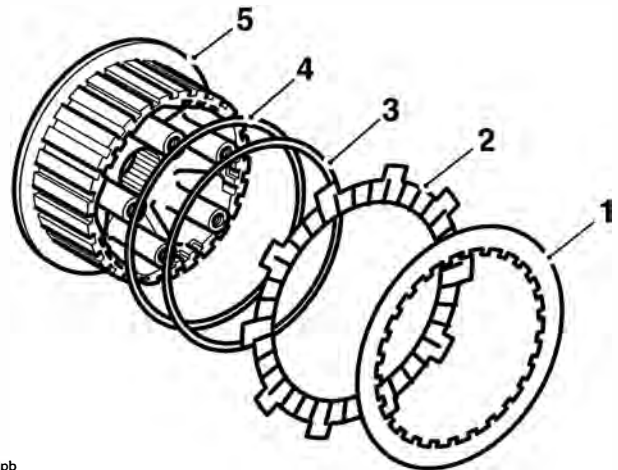

dpb

- 1. Steel plate**
- 2. Inner friction plate**
- 3. Anti-judder spring**
- 4. Anti-judder seat washer**
- 5. Clutch inner drum**

### Note:

- The inner and outermost friction plates are different to the remainder and are also different to each other. They must be fitted in their noted positions.
- The three outer steel plates may be different to the other plates, depending on the clutch pack height settings used during manufacture (see page 4-8). They must be fitted in their noted positions.
- Store all plates in their correct fitted order to avoid confusion on installation.
- Refer to the following page of this section for details of clutch friction plate checking.
- It is not normally necessary to disassemble the clutch further, but if the clutch inner and outer drums are to be removed, proceed as follows:

- Engage second gear and lock the inner and outer clutch drums together using service tool T3880306.

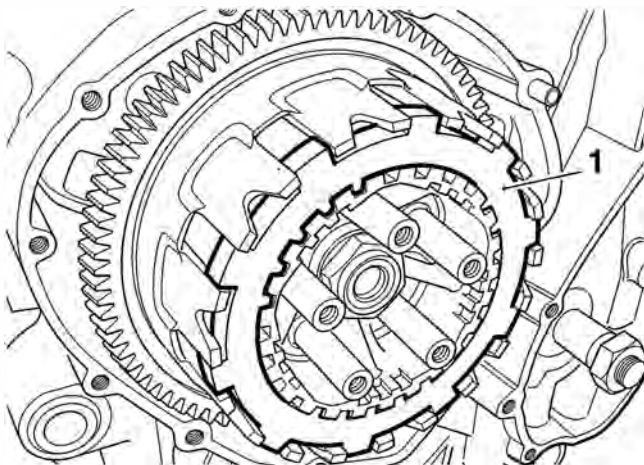

**1. Service Tool T3880306**

- Depress the rear brake pedal to prevent the engine from turning, then release the clutch centre nut.
- Remove the centre nut (discard the nut), Belleville washer, flat washer, clutch inner drum and thrust washer.

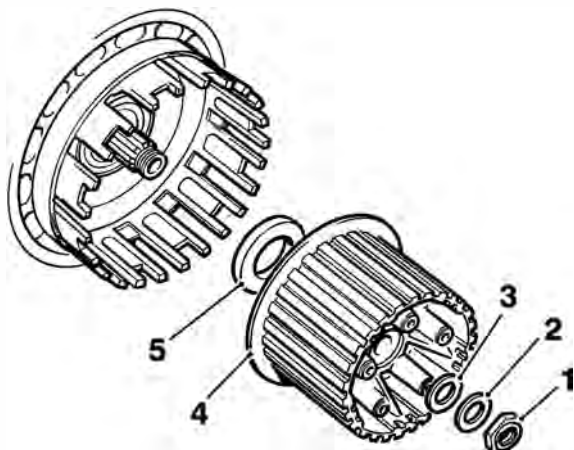

- Centre nut
- Belleville washer
- Flat washer
- Inner drum
- Thrust washer

- Slide the clutch outer drum assembly gently backwards and forwards to dislodge the inner bearing sleeve. Carefully remove the bearing sleeve while supporting the clutch drum.

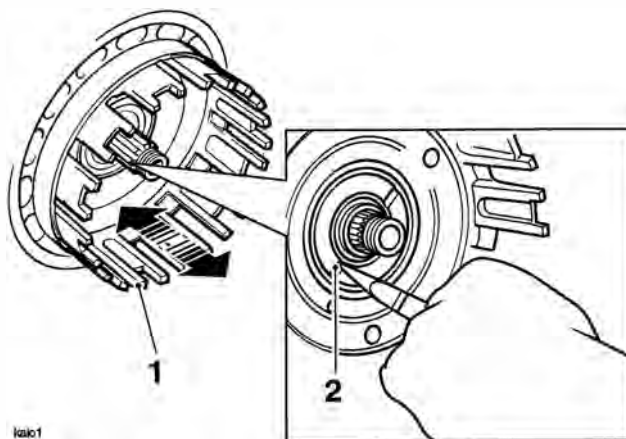

- Outer drum
- Bearing sleeve

- Remove the clutch outer drum leaving the oil pump drive sprocket, bearing and sleeve in place on the input shaft.

## Clutch Plate Inspection

### Friction Plate Thickness

- If any friction plate thickness is outside the service limit, replace the friction plates as a set.

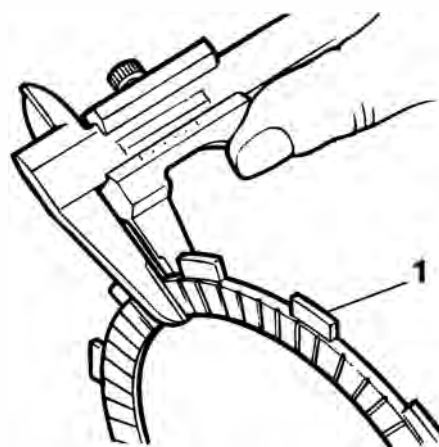

- Clutch friction plate

### Friction plate thickness - all plates

Standard	3.00 mm
Service limit	2.80 mm

# Clutch

## Steel Plate Bend/warp

Check all plates for bend and warp as follows:

1. Place the plate being checked on a clean surface plate and attempt to pass a feeler gauge of the maximum specified thickness between the steel plate and surface plate at several points around the plate. If the feeler gauge can be passed beneath the steel plate at any point, renew the plates as a set.

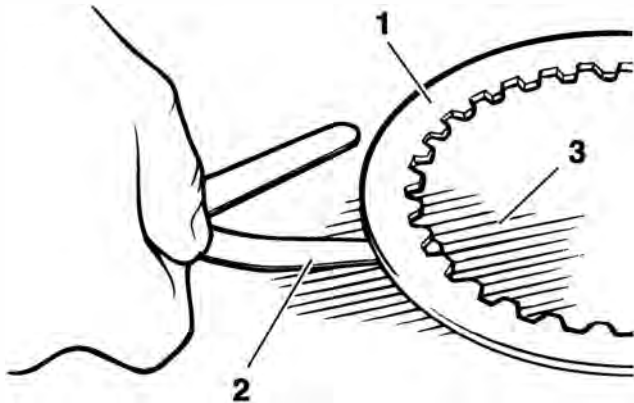

gaas

1. Friction plate
2. Feeler gauge
3. Surface plate

## Steel plate bend/warp

Standard	up to 0.15 mm
Service limit	0.20 mm

## Clutch Pack Height

The clutch pack height should only be measured if the friction plates and the steel plates have been replaced.

The clutch pack height is critical for a smooth operation of the transmission and must be measured prior to installation of new clutch plates.

If used clutch plates are being re-fitted, the clutch pack height measurement is not necessary, as the plates may not be worn to the service limit (and are therefore still serviceable), but could fall outside of the clutch pack height tolerance on page 4.9 when measured.

If building a new clutch pack its height must be correct. To achieve this, build the new clutch pack with the following:

- 1 x new outer friction plate;
- 7 x new friction plates;
- 1 x new inner friction plate;
- 6 x steel plates, 2.0 mm thick;
- 2 x steel plate, 1.6 mm thick.

1. Arrange the new friction and new steel plates in a stack as shown below.

## Friction Plate and Steel Plate Arrangement

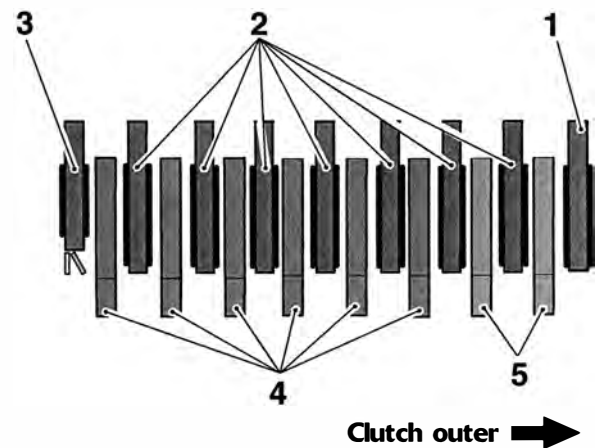

T0944\_3

1. Outer friction plate
2. Friction plates
3. Inner friction plate
4. Steel plate, 2.0 mm thickness
5. Steel plate, 1.6 mm thickness

- Place the assembled clutch pack on a flat surface and measure its height as shown below.

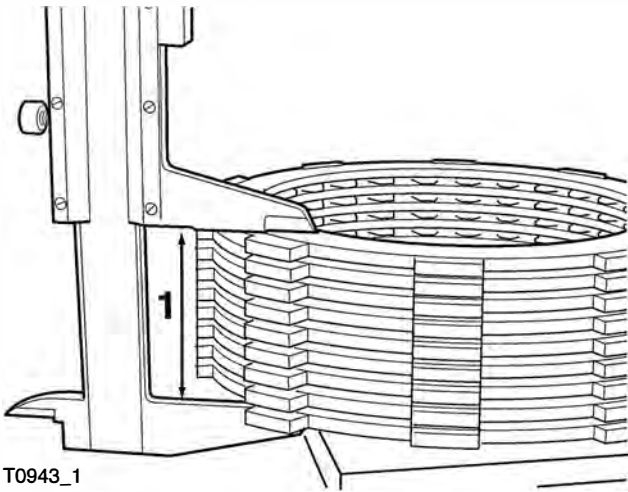

T0943\_1

### 1. Clutch pack height

- The correct clutch pack height for this clutch assembly is shown in the table below.

Standard height in mm	Tolerance in mm
42.20	+0.34/-0.66

- If the clutch pack height measurement is incorrect, proceed as described below/opposite:

### Clutch Pack Height Too High

#### Note:

- No more than three 1.6 mm thick steel plates are to be used in the clutch pack.

- Replace the 2.0 mm steel plate next to the 1.6 mm steel plate (indicated below) with a new 1.6 mm steel plate.

Clutch outer →

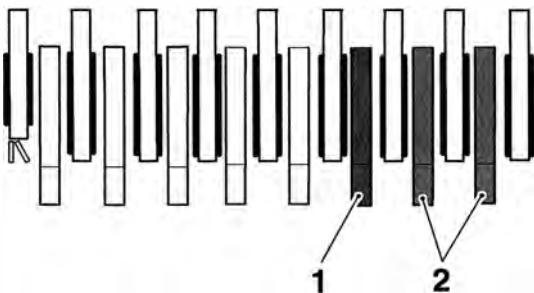

- 2.0 mm steel plate to be replaced
- 1.6 mm steel plates

- Re-check the clutch pack height as described earlier.

### Clutch Pack Height Too Low

#### Note:

- At least one 1.6 mm steel plate must be in the clutch pack.
- If the clutch pack height is too low, replace the 1.6 mm steel plate indicated below with a new 2.0 mm steel plate.

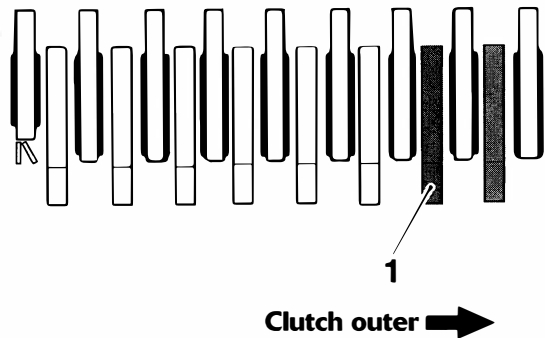

T0944\_2

- 1.6 mm steel plate to be replaced

- Re-check the clutch pack height as described earlier.

# Clutch

## Assembly

1. To fully engage the outer drum, insert a suitable tool to preload and align the primary gear and backlash eliminator gear through the hole shown in the illustration below.

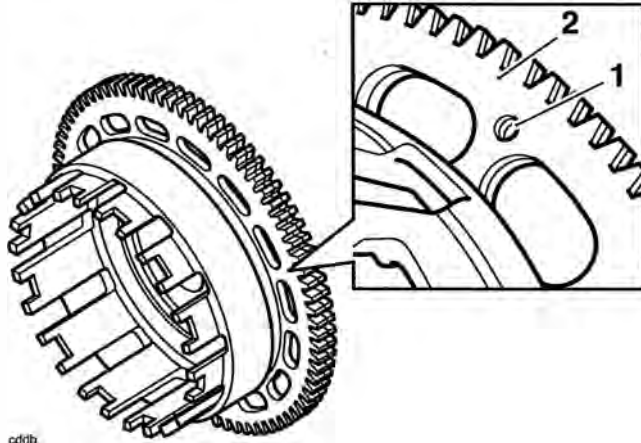

1. Alignment hole
2. Outer drum

2. Position the clutch outer drum assembly to the input shaft and align the oil pump drive pegs with the corresponding holes in the rear of the clutch outer drum.

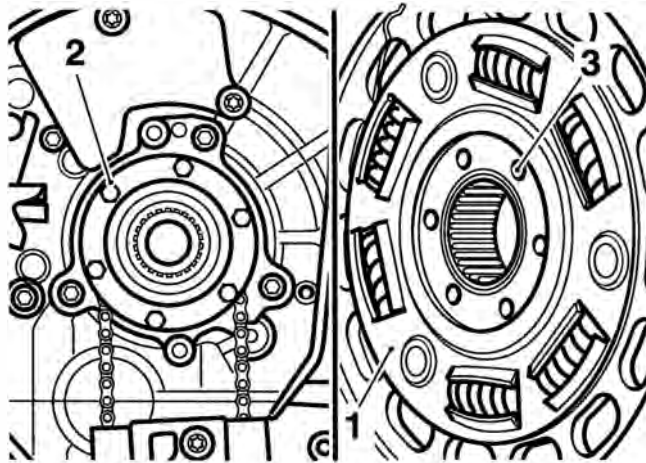

1. Clutch outer drum
2. Oil pump sprocket drive pegs
3. Oil pump drive holes

3. While holding the clutch outer drum in position and ensuring correct engagement with the oil pump drive, refit the bearing sleeve and bearing.

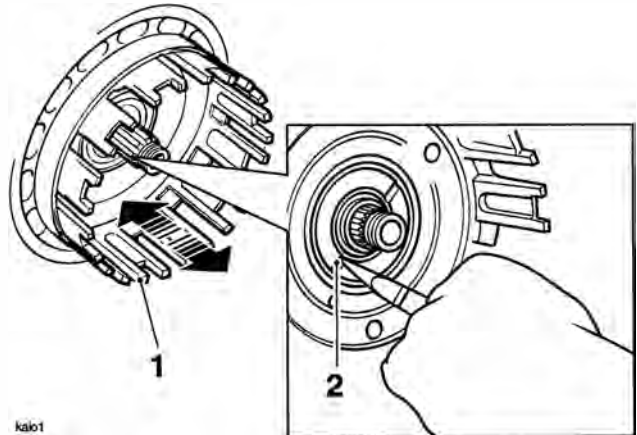

1. Outer drum
2. Bearing sleeve

### Note:

- When the bearing sleeve is correctly fitted, it will be a flush fit with the clutch drum face.

4. Fit the thrust washer to the shaft.
5. Fit the clutch inner drum.
6. Fit the flat washer, a new Belleville washer ('OUT' mark facing outwards), and refit the centre nut.

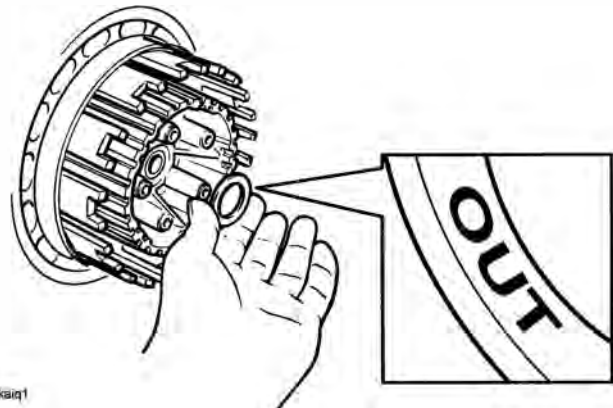

**Belleville Washer 'OUT' Mark**

7. Lock the inner and outer drums together using service tool T3880306. Depress the rear brake pedal to prevent the engine from turning, and tighten the clutch centre nut to **98 Nm**. Remove the service tool.
8. Using a suitable pin punch, stake the nut to the shaft.

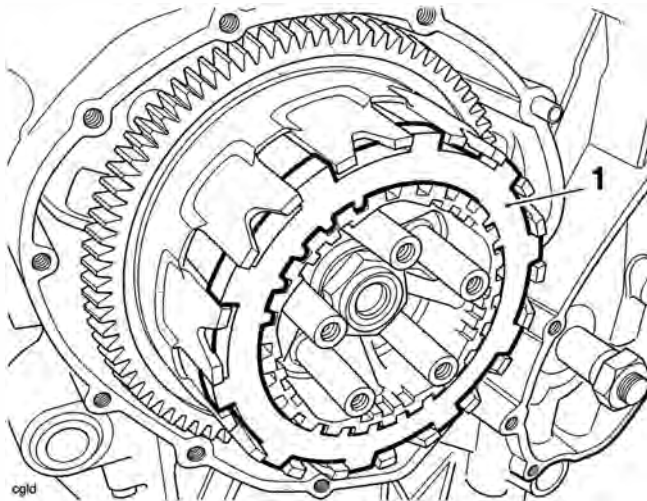

**1. Service tool T3880306**

9. Disengage second gear and check for free rotation of the clutch inner drum.
10. Coat all clutch friction plates in clean engine oil before fitting the friction plates, steel plates, anti-judder spring and anti-judder seat washer to the clutch basket in the same order and orientation as noted during removal.

**Note:**

- **The inner and outermost friction plates are different to the remainder and are also different to each other. They must be fitted in their noted positions.**

- **The three outer steel plates may be different to the other plates, depending on the clutch pack height settings used during manufacture (see page 4-8). They must be fitted in their noted positions.**

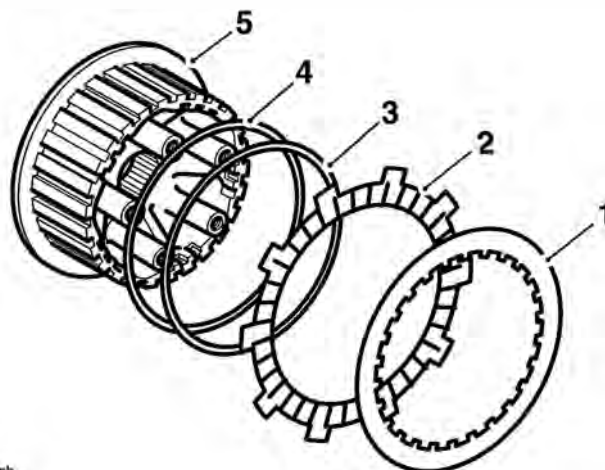

lpb

- 1. Steel plate**
- 2. Inner friction plate**
- 3. Anti-judder spring**
- 4. Anti-judder seat washer**
- 5. Clutch inner drum**

# Clutch

---

11. Refit the clutch pull-rod.
12. Refit the clutch pressure plate together with the springs and bolts. Tighten the bolts to **10 Nm**.

**Note:**

- **The pull-rod should be free to move in and out and also it should be free to turn.**

13. Clean and refit the clutch cover incorporating a new gasket. Tighten the clutch cover bolts to **9 Nm**.

14. Refit the clutch cable to the actuating arm at the clutch end (see page 4-5).
15. Set the clutch adjustment (see page 4-5).
16. Reconnect the battery positive (red) lead first.
17. Refit the rider's seat (see page 16-13).

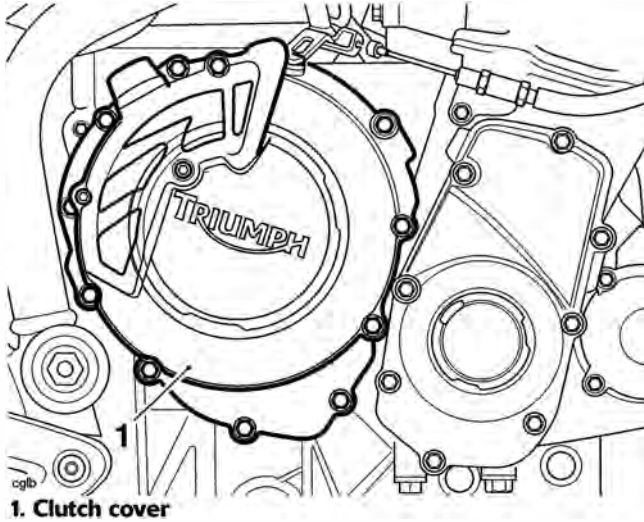



# 5 Crankshaft, Connecting Rods and Pistons

## Table of Contents

Exploded View - Crankshaft, Connecting Rod, Piston and Liner.....	5.2
Exploded View - Crankcase.....	5.3
Crankcases.....	5.4
Disassembly.....	5.4
Assembly.....	5.4
Crankshaft.....	5.6
Removal.....	5.6
Installation.....	5.6
Connecting Rods.....	5.8
Removal.....	5.8
Installation.....	5.8
Connecting Rod Big End Bearing Selection/Crankshaft Journal Wear Check.....	5.10
Checking the Measured Clearance.....	5.10
Connecting Rod Bearing Selection.....	5.11
Crankshaft main bearing/journal wear.....	5.12
Pistons.....	5.13
Disassembly.....	5.13
Piston Wear Check.....	5.14
Cylinder Wear.....	5.16
Cylinder Liners.....	5.17
Removal.....	5.17
Installation.....	5.18
Crankcase Breather.....	5.18

# Crankshaft, Connecting Rods and Pistons

## Exploded View - Crankshaft, Connecting Rod, Piston and Liner

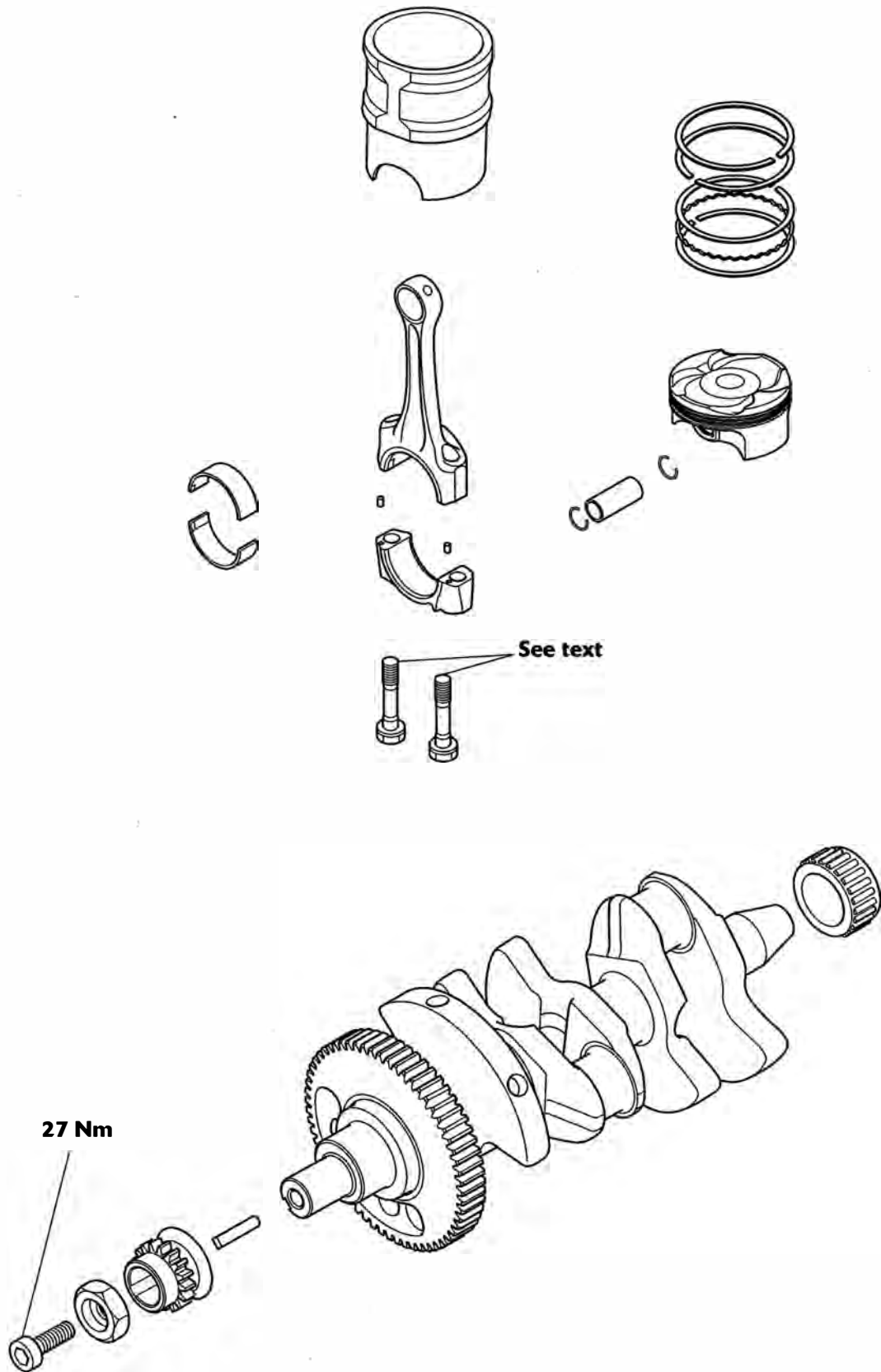

## Exploded View - Crankcase

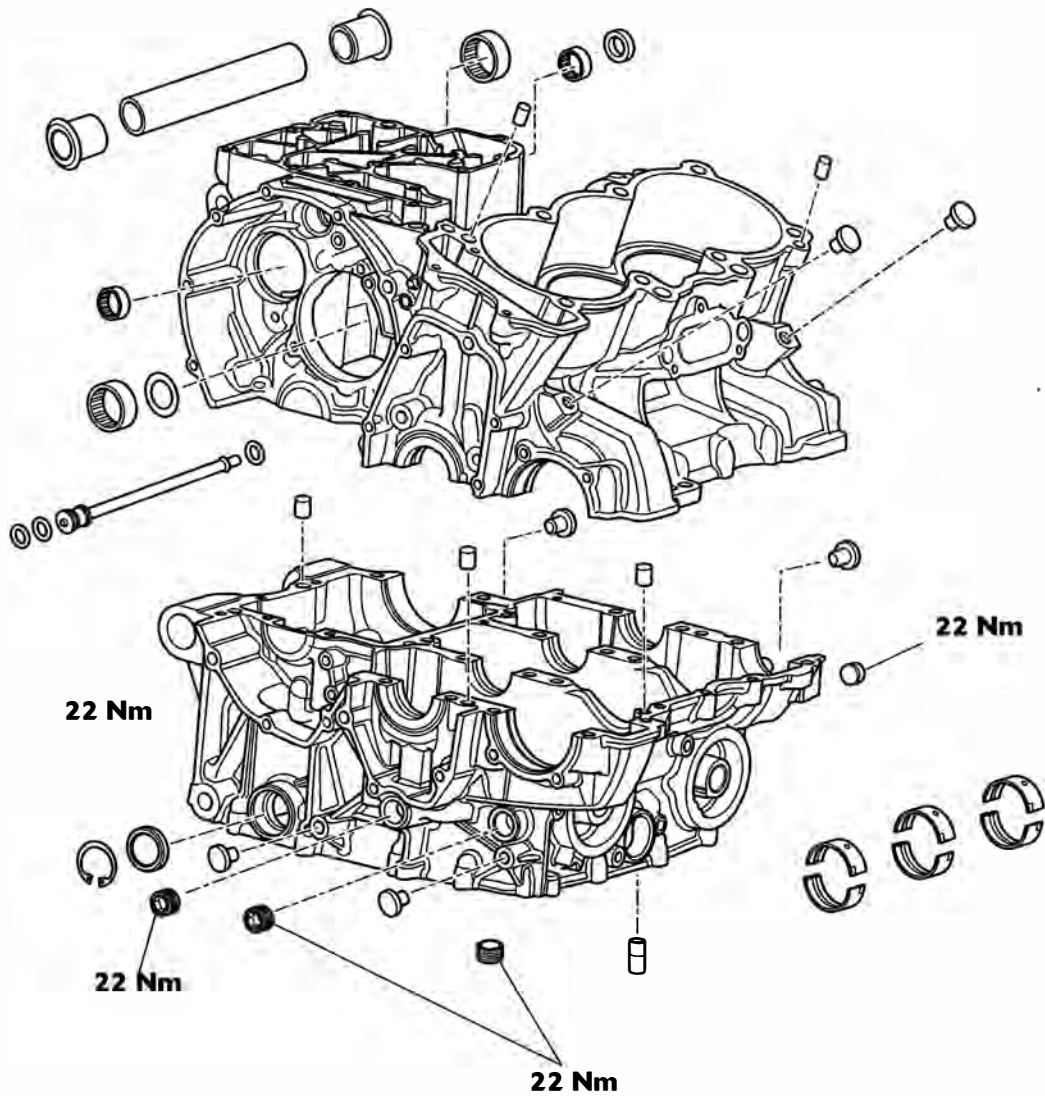

# Crankshaft, Connecting Rods and Pistons

## Crankcases

### **Caution**

The upper and lower crankcases are machined as a matched set and must never be assembled to non-matching halves. Doing so may cause seizure of the engine.

1. Remove the engine from the frame (see page 9-3).
2. Remove the sump (see page 8-15).
3. Remove the engine covers (see pages 3-8, 4-6 and 7-21).
4. Remove the clutch (see page 4-6).
5. Remove the oil pump (see page 8-8).

## Disassembly

### **Caution**

Failure to follow the correct screw release sequence may result in permanent crankcase damage.

1. Invert the engine to give access to the lower crankcase bolts.
2. Release the lower crankcase bolts in the sequence shown in the diagram below. Note the position of the hardened washers under bolts 19 to 26.

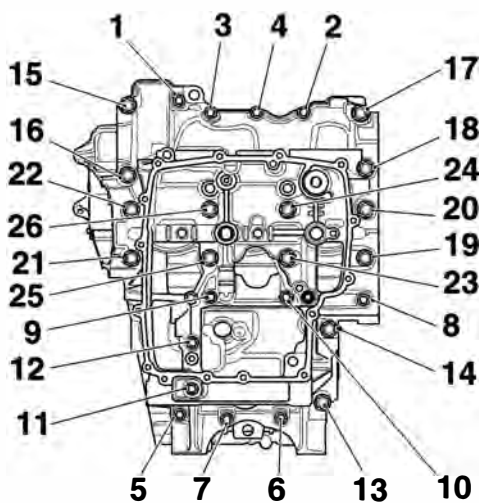

**Crankcase Bolt Release Sequence**

3. Separate the lower and upper crankcases ensuring that the 3 locating dowels remain in the upper crankcase.

### **Caution**

Do not use levers to separate the upper and lower sections of the crankcase or damage to the crankcases could result.

## Note:

- At this point the transmission shafts, balancer, crankshaft, bearings etc. can be removed.

## Note:

- The position of each individual bearing shell prior to removal.
- Collect the piston cooling jets from below the upper main bearings, noting that the piston cooling jet for number 3 cylinder is longer and has a larger diameter drilling than the piston cooling jets for number 1 and 2 cylinders. It can also be identified by its smaller outside diameter and a groove around its circumference.

## Assembly

1. Use high flash-point solvent to clean the crankcase mating faces. Wipe the surfaces clean with a lint-free cloth.
2. Fit the gearbox shafts (if removed), ensuring the locating ring and dowels on the output shaft bearings are positioned correctly in the crankcase.
3. Ensure that the transmission is in neutral.
4. Ensure that the 3 locating dowels are in position in the upper crankcase.

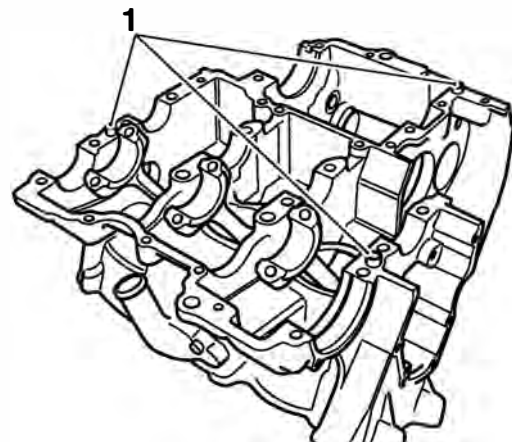

cdmx

**1. Locating dowels**

# Crankshaft, Connecting Rods and Pistons

- Apply a thin bead of silicone sealant (At the factory, ThreeBond 1215 is used) to the lower crankcase mating faces.

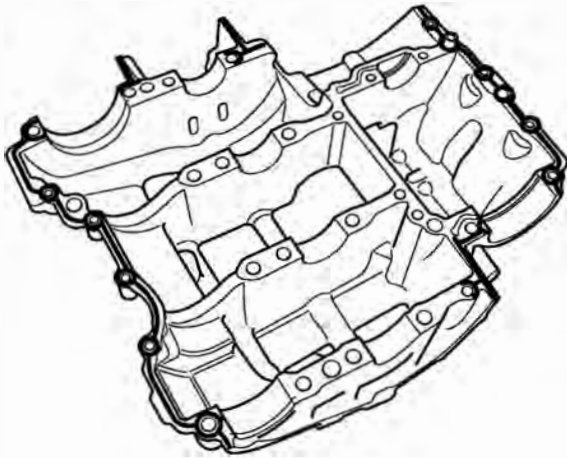

cdmy

Sealer areas

## ⚠ Caution

Do not use excessive amounts of sealer. The extra sealer may become dislodged and could block the oil passages in the crankcases causing severe engine damage.

- If removed, insert the three piston cooling jets into the main bearing housings in the upper crankcase.

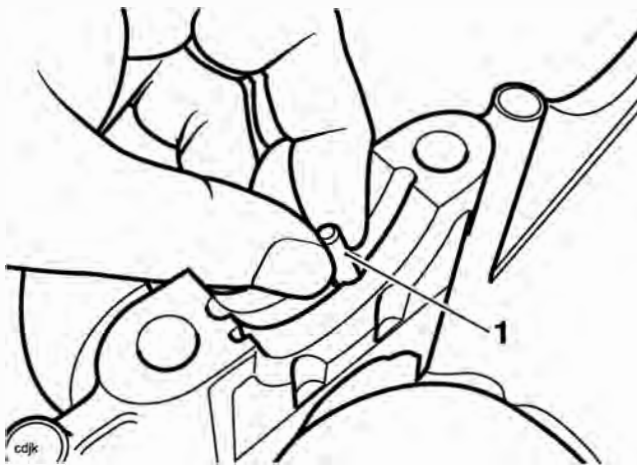

1. Piston cooling jet

## ⚠ Caution

Ensure the three piston cooling jets are installed. If the piston cooling jets are omitted, oil pressure will be reduced. Running the engine with low oil pressure will cause severe engine damage.

### Note:

- The piston cooling jet for number 3 cylinder is longer and has a larger diameter drilling than the piston cooling jets for number 1 and 2 cylinders. It can also be identified by its smaller outside diameter and a groove around its circumference. Piston cooling jets must not be installed incorrectly.
- Install and lubricate the crankshaft bearing shells with clean engine oil (see bearing selection on page 5-12 before proceeding).
  - Lubricate the crankshaft journals with clean engine oil.
  - Position the lower crankcase to the upper. An assistant may be required to support the crankcase during alignment.
  - Fit the screws into the lower crankcase and hand tighten until the bolt heads are near contact with the crankcase. Note the position of the hardened washers under bolts 1 to 8.

### Note:

- The crankcase screws are tightened in stages.
- Two different sizes of crankcase screw are used. All screws are tightened through the first stage of the tightening procedure but only the M8 size screws are tightened at the second stage.

## ⚠ Caution

Failure to follow the correct screw tightening sequence may result in permanent crankcase damage.

### Stage 1 - all screws

- In the sequence shown below, tighten all crankcase screws to **12 Nm**.

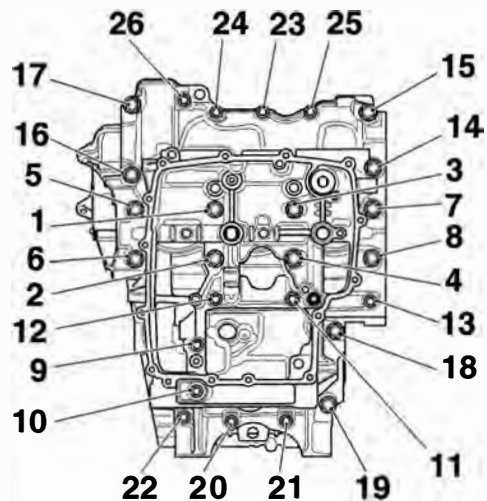

Crankcase Bolt Tightening Sequence

# Crankshaft, Connecting Rods and Pistons

## Stage 2 - M8 screws only

1. In the correct sequence, tighten only the M8 size crankcase screws (numbers 1 to 8) to **22 Nm**.
2. In the correct sequence, tighten only the M8 size crankcase screws (number 9 to 14) to **22 Nm**.

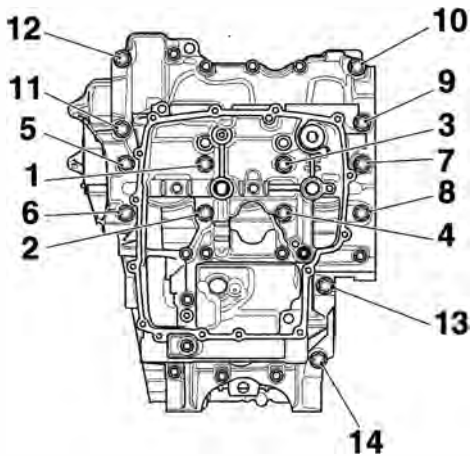

### M8 Crankcase Bolt Tightening Sequence

3. Rotate the crankshaft clockwise. Check for tight spots and rectify as necessary.
4. Refit the oil pump (see page 8-13).
5. Refit the clutch (see page 4-10).
6. Refit the engine covers (see pages 3-11, 4-12 and 7-22).
7. Refit the sump (see page 8-16).
8. Install the engine in the frame (see page 9-5).

## Crankshaft

### Removal

1. Remove the alternator rotor from the crankshaft (see page 17-19).
2. Separate the two halves of the crankcase (see page 5-4).
3. Remove the connecting rods (see page 5-8).
4. Remove the camshaft drive chain (see page 3-18).
5. Release and remove the crankshaft from the upper crankcase.

### Note:

- Identify the location of each bearing shell.
  - Remove all bearings and inspect for damage, wear, overheating (blueing) and any other signs of deterioration. Replace the bearings as a set if necessary.
  - Collect the piston jets from below the upper main bearings.
  - If the camshaft drive chain sprocket is removed from the crankshaft for any reason, always install a new fixing. Tighten to 27 Nm.
6. Remove the balancer (see page 6-3).

### Installation

 <b>Caution</b>
Always check the bearing journal clearance (see page 5-12), before final assembly of the crankshaft. Failure to correctly select crankshaft bearings will result in severe engine damage.

1. If removed, insert the three piston cooling jets into the main bearing housings in the upper crankcase.

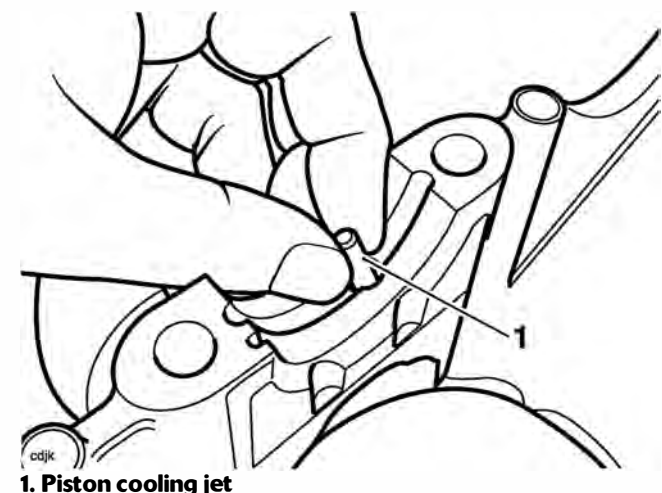

1. Piston cooling jet



## Caution

Ensure the three piston cooling jets are installed. If the piston cooling jets are omitted, oil pressure will be reduced. Running the engine with low oil pressure will cause severe engine damage.

### Note:

- The piston cooling jet for number 3 cylinder is longer and has a larger diameter drilling than the piston cooling jets for number 1 and 2 cylinders. It can also be identified by its smaller outside diameter and a groove around its circumference. Piston cooling jets cannot be installed incorrectly.
2. Select and fit new main and big end shell bearings (see page 5-12).

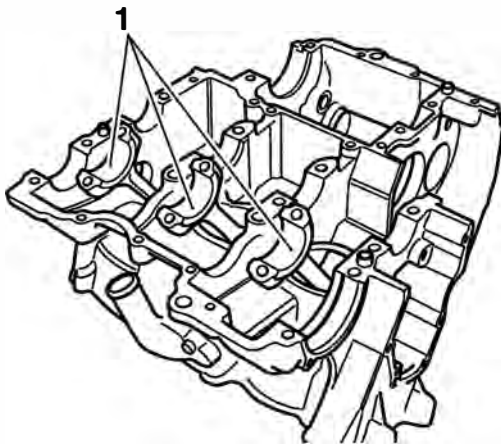

cdmx

### 1. Big end shells

3. Lubricate all bearings with a 50/50 solution of engine oil and molybdenum disulphide grease.
4. Ensure that the crankshaft is clean, and that the oilways within the crank are clean and free from blockages and debris.
5. Refit the balancer (see page 6-4).

6. Install the crankshaft ensuring that the crank pins align with the big ends and that the crankshaft and balancer gear markings align as shown in the next illustration.

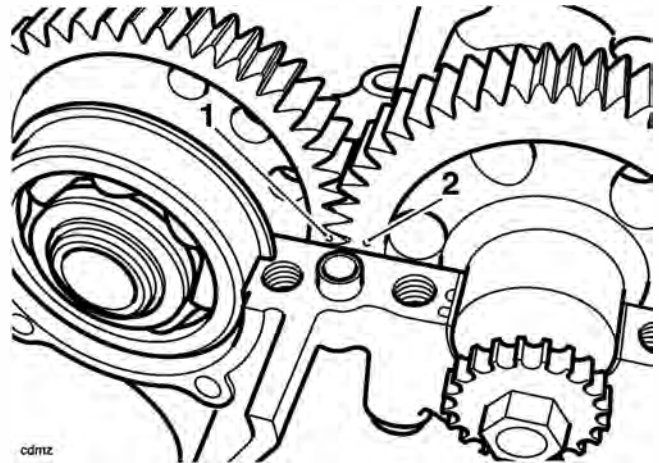

cdm12

### 1. Balancer backlash and drive gear markings

### 2. Crankshaft markings

7. Refit the connecting rods (see page 5-8).
8. If removed, refit the transmission shafts.
9. Assemble the crankcases (see page 5-4).
10. Assemble the alternator rotor (see page 17-20).
11. Refit the camshaft drive chain (see page 3-20).

# Crankshaft, Connecting Rods and Pistons

## Connecting Rods

### Removal

Connecting rods may be removed from the engine after first removing it from the frame. The cylinder head must be removed and the crankcase halves separated.

1. Mark each big end cap and connecting rod to identify both items as a matched pair and to identify the correct orientation of the bearing cap to the connecting rod.
2. Release the connecting rod bolts and remove the big end cap. Ensure that the bearing shell remains in place in the cap.

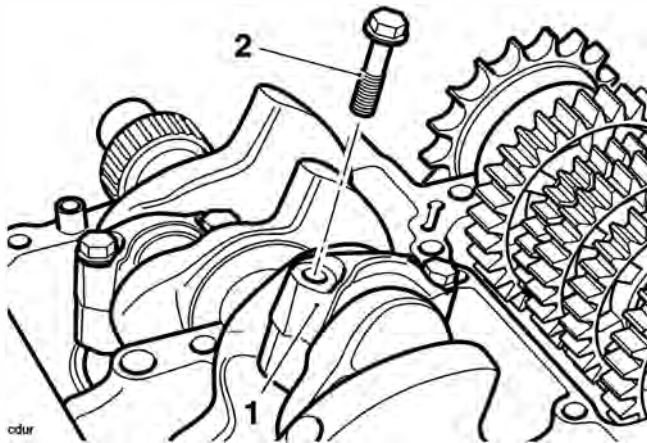

1. Big end cap
2. Connecting rod bolt

### Note:

- It may be necessary to gently tap the big end cap with a rubber mallet to release the cap.
3. Push the connecting rod up through the crankcase and collect the piston and connecting rod from the top.
  4. Label the assembly to identify the cylinder from which it was removed.

### Caution

Never re-use connecting rod bolts. If the connecting rod cap is disturbed, always renew the bolts. Using the original bolts may lead to severe engine damage.

5. Remove the liner using tool T3880101 (see page 5-17).
6. Detach the piston from the connecting rod (see page 5-13).

### Installation

### Note:

- Connecting rod bolts are treated with an anti-rust solution which must not be removed.
- Clean the connecting rod with high flash-point solvent.
- Remove all bearings and inspect for damage, wear and any signs of deterioration and replace as necessary.

### Warning

Connecting rod bolts MUST only be used once. If the bolts are removed or undone for any reason, new bolts MUST always be used.

Re-using bolts can cause connecting rods and their caps to detach from the crankshaft causing severe engine damage, loss of motorcycle control and an accident.

### Note:

- Ensure the piston is fitted correctly to the connecting rod.
- If a previously run engine is being rebuilt, always ensure that the piston and con-rod are assembled in the same orientation, and to the same cylinder, as prior to strip-down.

1. Fit the piston onto the connecting rod (see page 5-15).
2. Apply silicone sealer to the liner-to-crankcase mating face (At the factory, Three Bond 1215 is used).

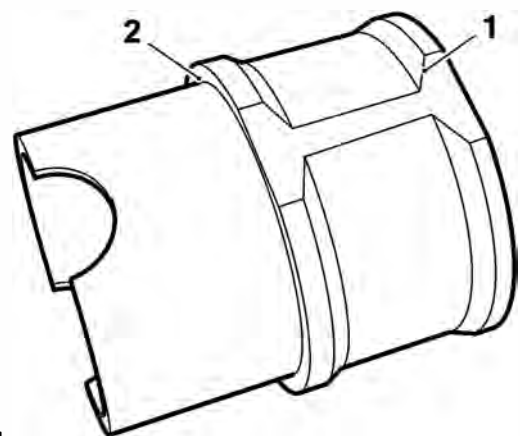

cbef\_1\_1

### 1. Liner

### 2. Sealer area

3. Fit the piston and connecting rod assembly into the liner from the bottom.
4. Fit the liner into the crankcase ensuring that the arrow on the piston faces forward.



5. The liners must be positioned such they do not touch each other - it must be possible to pass a 0.1 mm feeler gauge between the centre liner and its adjacent liner on either side. If the liners touch at any point, rotate the liners until there is a minimum 0.1 mm clearance.

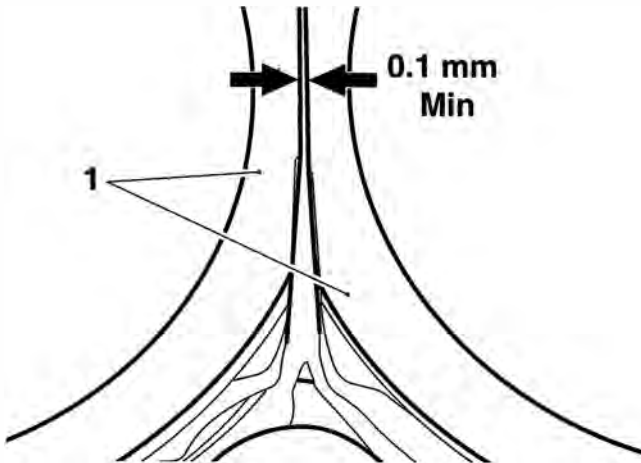

1. Liners

**Note:**

- Ensure that the piston/liner/connecting rod assembly aligns correctly with the crankshaft journal during assembly into the crankcase.

6. Select the big end bearing shells (see page 5-10).
7. Fit the bearing shells to the connecting rod and big end cap and lubricate with a 50/50 solution of engine oil and molybdenum disulphide grease.
8. Align the connecting rod to the crankshaft and fit the big end cap.

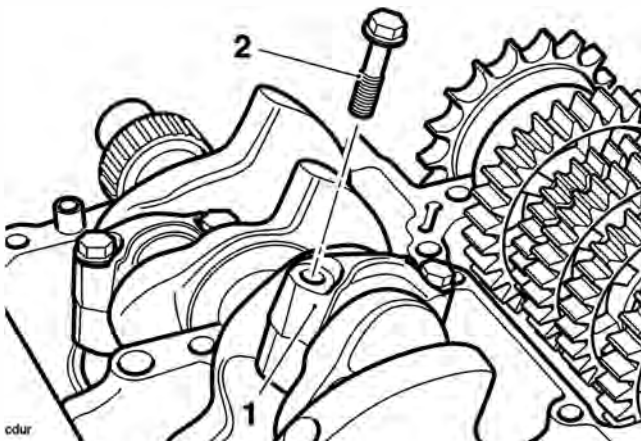

1. Big end cap  
2. Connecting rod bolt

**! Caution**

The torque characteristics of the connecting rod bolts are sensitive to the correct lubrication being applied. If the threads and under head areas are not lubricated with molybdenum disulphide grease, the bolts may be stretched and may become loose when in service resulting in an expensive engine failure.

9. Lubricate the threads and under-head area of the new bolts with molybdenum disulphide grease. Tighten the bolts evenly and progressively in five stages as follows:

**! Caution**

The torque characteristics of the connecting rod bolts are sensitive to the rate at which they are tightened. If all the torque is applied in one action, the bolt may be stretched and may become loose when in service resulting in an expensive engine failure.

- tighten to **22 Nm**;
- release **120°**;
- tighten to **10 Nm**;
- tighten to **14 Nm**;
- tighten through **120°** of bolt rotation as measured using the Triumph torque turn gauge **3880105-T0301**.

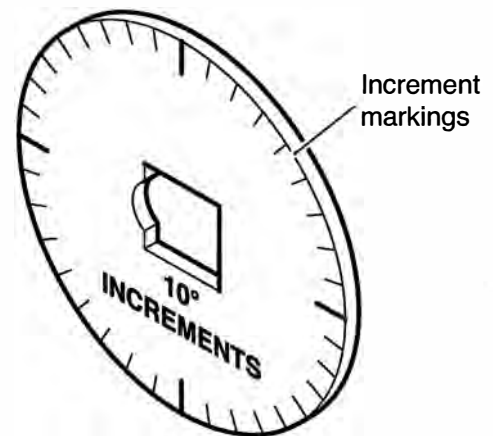

cbxt

**Service Tool 3880105-T0301**

# Crankshaft, Connecting Rods and Pistons

## Connecting Rod Big End Bearing Selection/Crankshaft Journal Wear Check

1. Measure the bearing and crankshaft journal clearance as follows.

### Note:

- The crankshaft journal clearances are measured using 'Plastigage' (Triumph part number 3880150-T0301).
  - Do not turn the connecting rod and crankshaft during the clearance measurement as this will damage the 'Plastigage'.
- a) Remove the big end cap from the journal to be checked.
  - b) Wipe the exposed areas of the crankshaft journal, and the bearing face inside the cap.
  - c) Apply a thin smear of grease to the journal and a small quantity of silicone release agent to the bearing.
  - d) Trim a length of the Plastigage to fit across the journal. Fit the strip to the journal using the grease to hold the Plastigage in place.
  - e) Lubricate the threads and under-head of the bolt with molybdenum disulphide grease. Refit the bearing and cap and tighten the big end bolts (see page 5-9).
  - f) Release the bolts and remove the cap being measured. Using the gauge provided with the Plastigage kit, measure the width of the compressed Plastigage.

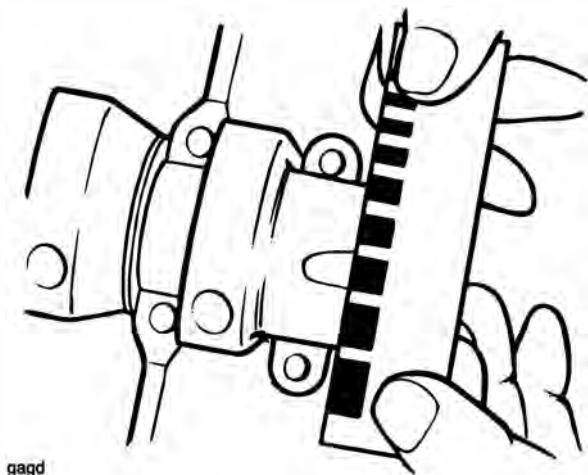

## Checking the Measured Clearance

Con rod big end bearing/crankshaft journal clearance

Standard:	0.035 - 0.065 mm
Service limit:	0.070 mm

### Note:

- If the measured clearance exceeds the service limit, measure the crankshaft journal diameter.

## Crankshaft Journal diameter

Standard:	32.984 - 33.000 mm
Service limit:	32.960 mm

### Note:

- If any crankshaft journal has worn beyond the service limit, the crankshaft must be replaced. Due to the advanced techniques used during manufacture, the crankshaft cannot be re-ground and no oversize bearings are available.

# Crankshaft, Connecting Rods and Pistons

## Connecting Rod Bearing Selection

Minor differences in crankshaft dimensions are compensated for by using selective bearings. For further information on bearing part number to colour cross-references, see the latest parts information.

1. Select the correct big end bearing shell as follows:
  - Measure each crankshaft journal diameter.
  - Select the correct bearings by matching the information found with the chart below.

### Note:

- All dimensions in millimetres.

### Big end bearing selection chart

Shell Colour	White	Red
Con-rod Big End Bore Dia.	36.009 36.000	36.009 36.000
Crankshaft Journal Dia.	33.000 32.992	32.991 32.984
Running Clearance	0.065 0.035	

For instance:

Con-rod Big End Diameter	36.002
Crankshaft Journal Diameter	32.987
Required Bearing	Red

### Note:

- Repeat the measurements for all connecting rods and their respective crankshaft journals.
- It is normal for the bearings selected to differ from one connecting rod to another.

2. Install the new bearings in the connecting rod.

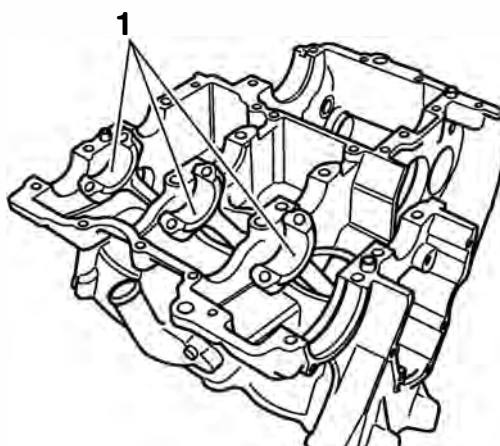

cdmx

### 1. Big end bearings



### Caution

Always confirm, using the Plastigage method, that the running clearance is correct before final assembly. Severe engine damage could result from incorrect clearance.

# Crankshaft, Connecting Rods and Pistons

## Crankshaft main bearing/journal wear

Main Bearing Selection Chart (all dimensions in millimetres)						
Shell Colour	White	Red	Red	Blue	Blue	Green
Crankcase Bore	35.982 35.973	35.981 35.973	35.989 35.981	35.988 35.981	35.997 35.989	35.997 35.989
Journal Dia.	33.000 32.993	32.992 32.984	33.000 32.993	32.992 32.984	33.000 32.993	32.992 32.984
Running Clearance	0.044 0.020	0.044 0.020	0.043 0.021	0.043 0.020	0.043 0.020	0.044 0.020

Minor differences in crankshaft and crankcase dimensions are compensated for by using selective bearings. For further information on bearing part number to colour cross-references, see the latest parts information.

- Measure the bearing to crankshaft main journal clearance using Plastigage (Triumph part number 3880150-T0301) (see page 5-10).

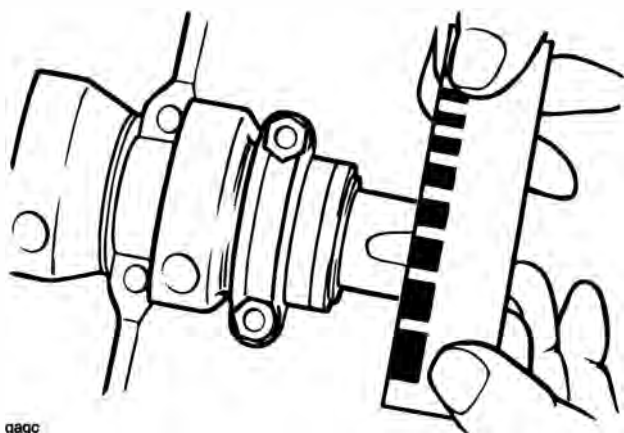

**Checking Crankshaft Journal Clearance using Plastigage**

### Crankshaft main bearing/journal clearance

Standard:	0.020 - 0.044 mm
Service limit:	0.07 mm

If the clearance exceeds the service limit, measure the diameter of the crankshaft main journal.

### Crankshaft main journal diameter

Standard:	32.984 – 33.000 mm
Service limit:	32.960 mm

#### Note:

- **If any journal has worn beyond the service limit, the crankshaft must be replaced. Due to the techniques used during manufacture, the crankshaft cannot be reground and no oversize bearings are available.**

Select bearings as follows:

1. Measure and record the diameter of each crankshaft main bearing journal.
2. Measure and record each main bearing bore diameter in the crankcase (bearings removed).

Compare the data found with the chart above to select bearings individually by journal.

For example:

Crankshaft Journal diameter	32.995 mm
Crankcase Bore	35.997 mm
Bearing Required	Blue

# Crankshaft, Connecting Rods and Pistons

## Note:

- It is normal for the bearings selected to differ from one journal to another.
- It is also normal for there to be two options of bearing shell colour. In such cases, pick the shell size which gives the greater running clearance.



## Caution

Always confirm, using the Plastigage method, that the running clearance is correct before final assembly. Severe engine damage could result from incorrect clearance.

## Crankshaft End Float

Standard	0.15 - 0.30 mm
----------	----------------

## Note:

- Crankshaft end float is controlled by the tolerances in crankshaft and crankcase machining. No thrust washers are used. If the crankshaft end float is outside the specified limit, the crankshaft and/or the crankcases must be replaced.

## Pistons

### Disassembly

#### Note:

- It is not necessary to remove the connecting rods from the crankshaft.

1. Remove the cylinder head (see page 3-20).
2. Remove the liner, using the frame from tool T3880315, and tool T3880101 (see page 5-17).
3. Remove and discard the gudgeon pin circlip from one side of the piston.



cape

### Removing the Gudgeon Pin Circlip

4. Remove the gudgeon pin by pushing the pin through the piston and rod toward the side from which the circlip was removed.



## Caution

Never force the gudgeon pin through the piston. This may cause damage to the piston which may also damage the liner when assembled.

#### Note:

- If the gudgeon pin is found to be tight in the piston, check the piston for a witness mark caused by the circlip. Carefully remove the mark to allow the pin to be removed.
5. Piston rings must be removed from the piston using hand pressure only. Do not over-extend the piston rings during removal.

#### Note:

- If the piston rings are to be re-used, note the orientation of the oil control rings prior to removal.

# Crankshaft, Connecting Rods and Pistons

## Piston Wear Check

1. Measure the piston outside diameter, 8 mm up from the bottom of the piston and at 90° to the direction of the gudgeon pin.

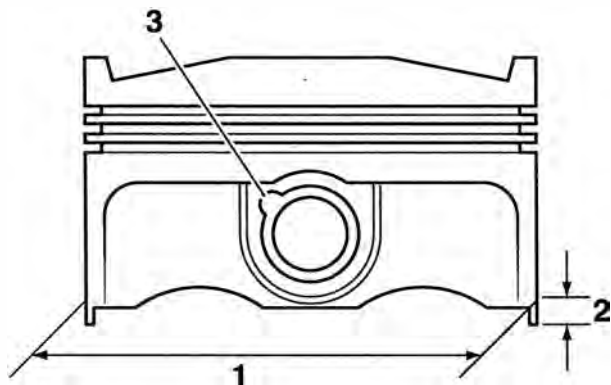

capf

1. Piston outside diameter
2. Measurement point
3. Circlip removal groove

All Cylinders	73.974 – 73.990 mm
Service limit	73.930 mm

Replace the piston if the measured diameter falls outside the specified limit.

## Piston Rings/Ring Grooves

Check the pistons for uneven groove wear by visually inspecting the ring grooves.

If all the rings do not fit parallel to the groove upper and lower surfaces, the piston must be replaced.

Clean the piston ring grooves.

Fit the piston rings to the pistons. Check, using feeler gauges, for the correct clearance between the ring grooves and the rings. Replace the piston and rings if outside the specified limit.



capg

## Piston Ring to Ring Groove Clearance Check

### Piston ring/Groove Clearance

Top ring	0.020 - 0.060 mm
Service limit	0.075 mm
Second	0.020 - 0.060 mm
Service limit	0.075 mm

# Crankshaft, Connecting Rods and Pistons

## Piston Ring Gap

### Note:

- **The piston ring gap, with the piston ring fitted in the liner, must be checked before final assembly.**

1. Place the piston ring inside the liner.
2. Push the ring into the top of the cylinder, using the piston to hold the ring square with the inside of the bore. Continue to push the ring into the bore until the third groove of the piston is level with the cylinder top, around the full circumference of cylinder.



**Aligning Piston Rings using the Piston**

1. Remove the piston and measure the gap between the ends of the piston ring using feeler gauges.

## Piston Ring End Gap Tolerances

Top	0.15 - 0.30 mm
Service limit	0.60 mm
Second	0.30 - 0.45 mm
Service limit	0.75 mm
Oil Control	0.20 - 0.70 mm
Service limit	1.00 mm

### Note:

- **If the end gap is too large, replace the piston rings with a new set**
- **If the gap remains too large with the new piston rings, both the pistons and barrels must be replaced**
- **If the gap is too small, check the cylinder bore for distortion, replacing as necessary. Do not file piston rings!**

## Piston Assembly

1. Clean the piston ring grooves and fit the piston rings to the piston.

### Note:

- **The top ring upper surface is marked 'N' and can be identified by a chamfer on the inside edge.**
- **The second ring upper surface is marked 'N2', and is plain on the inside edge**
- **When new, the oil control rings can be fitted with either face upward. Used oil control rings must be refitted in the same orientation as noted prior to removal.**

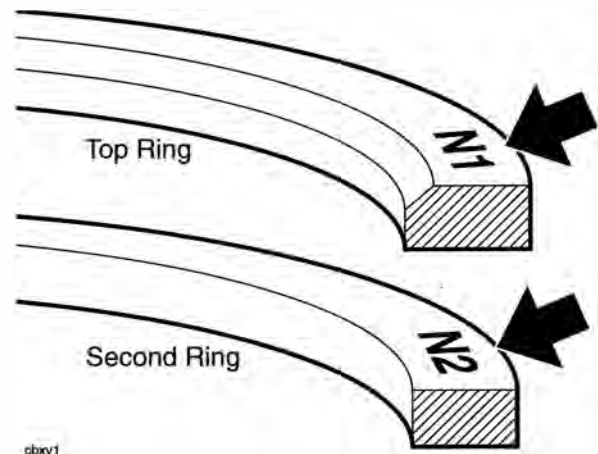

**Piston Ring Identification**

1. Fit the piston onto the connecting rod.

### Note:

- **Connecting rods may be fitted either way around. However, ensure all three are fitted the same way.**
2. Lubricate the piston, small end and gudgeon pin with a 50/50 solution of engine oil and molybdenum disulphide grease.
  3. Align the small end in the connecting rod with the gudgeon pin hole in the piston and fit the gudgeon pin.
  4. Fit new circlips on both sides of the gudgeon pin ensuring the circlips are correctly fitted in the grooves.

## Warning

Failure to use new gudgeon pin circlips could allow the pin to detach from the piston. This could seize the engine and lead to an accident.

# Crankshaft, Connecting Rods and Pistons

5. The piston ring gaps must be arranged as shown in the diagram below.

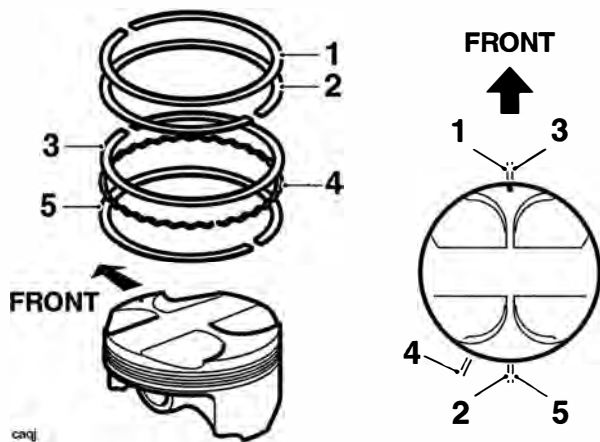

1. Top ring
2. Second ring
3. First steel oil control ring
4. Oil control ring expander
5. Second steel oil control ring

**Note:**

- The top ring gap should be positioned in the 12 o'clock position, and the second ring gap in the 6 o'clock position. The first steel oil control ring gap should be in the 12 o'clock position and the second steel oil control ring should be in the 6 o'clock position. The oil control ring expander should be in the 7 o'clock position.
6. Fit the piston into the liner from below using a gentle rocking motion to engage the rings in the bore.

## Cylinder Wear

Measure the inside diameter of each cylinder using an internal micrometer or similar accurate measuring equipment.

### Cylinder bore diameter

Standard:	74.040 – 74.060 mm
Service limit:	74.150 mm

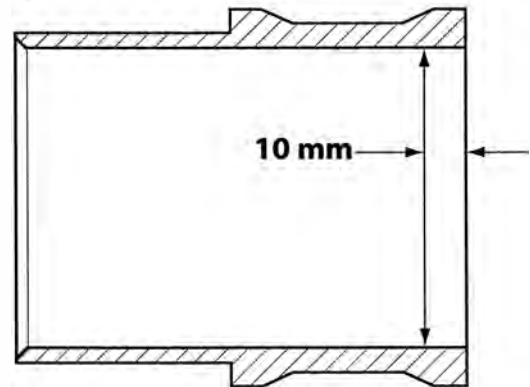

gaep

### Test Position For Bore Wear Check (bore shown in section)

1. Measure the inside diameter 10 mm from the top of the bore as shown above.
2. If the reading is outside the specified limits, replace the liner and piston as an assembly.



## Cylinder Liners

### Removal

1. Assemble the frame from tool T3880315 to tool T3880101 as shown below.

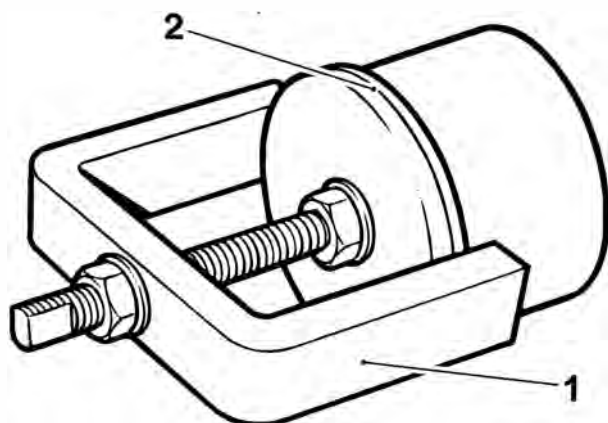

1. Frame from tool T3880315
2. Tool T3880101



1. Paint mark
2. Mark each liner to identify correct orientation and the cylinder number from which it has been removed.

3. Turn the crankshaft until the piston in the liner to be removed is at the bottom of its stroke.



1. Tool T3880315 and T3880101
2. Extraction nut
3. Locking nut

4. Check that the locking nut on tool T3880101 is loose, then fully unscrew the extraction nut.
5. Carefully fit the tool fully into the cylinder bore, positioning the tool legs on the crankcase. Turn the locking nut clockwise until the rubber sleeve on the tool tightly grips the bore of the liner.
6. Check that the tool legs are positioned to allow withdrawal of the liner, then turn the extraction nut clockwise to extract the liner. Take care to ensure that the piston/connecting rod is not allowed to fall against the inside of the crankcase.
7. Turn the locking nut counter-clockwise to release the liner.

### Note:

- The tool must be used to release the seal between the liner and the crankcase.
- It is not intended that the tool is used to fully extract the liner. Once the seal is released, the tool must be removed and the liner extracted by hand.

# Crankshaft, Connecting Rods and Pistons

## Installation

1. Thoroughly clean the liner removing all traces of old silicone sealer.
2. Remove all traces of sealer from the crankcase bores.
3. Apply silicone sealer to the liner to crankcase mating face (at the factory, ThreeBond 1215 is used).
4. Fit each liner over the piston using a gentle rocking motion to allow compression of the piston rings.

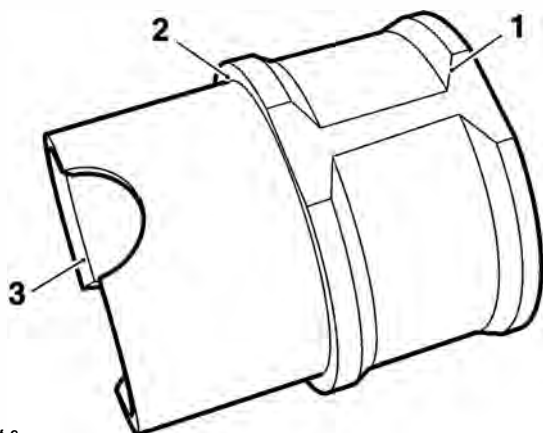

obef\_3

1. Liner
2. Sealer area
3. Chamfer

### Note:

- **The liners have a large chamfer at the bottom of the bore enabling fitting of the piston without need for a piston ring compressor.**



## Caution

Fit each liner over whichever piston is at TDC. When turning the engine, do not allow the pistons to contact the inside of the crankcase and also do not allow fitted liners to lift off the crankcase base.

5. Continue fitting each liner in turn until all are fitted and sealed.

### Note:

- **When the liners have been fitted, they should not be disturbed. If it is necessary to remove the liner after fitting, the sealer must be re-applied.**

## Crankcase Breather

The upper crankcase is fitted with a labyrinth type breather system, which requires no maintenance. During engine disassembly and overhaul, check the oil drain tube for blockage and contamination.

# 6 Balancer

## Table of Contents

- Exploded View - Balancer Shaft..... 6.2
- Balancer ..... 6.3
  - Removal ..... 6.3
  - Inspection ..... 6.3
  - Assembly/Installation..... 6.4

# Balancer

---

## Exploded View - Balancer Shaft

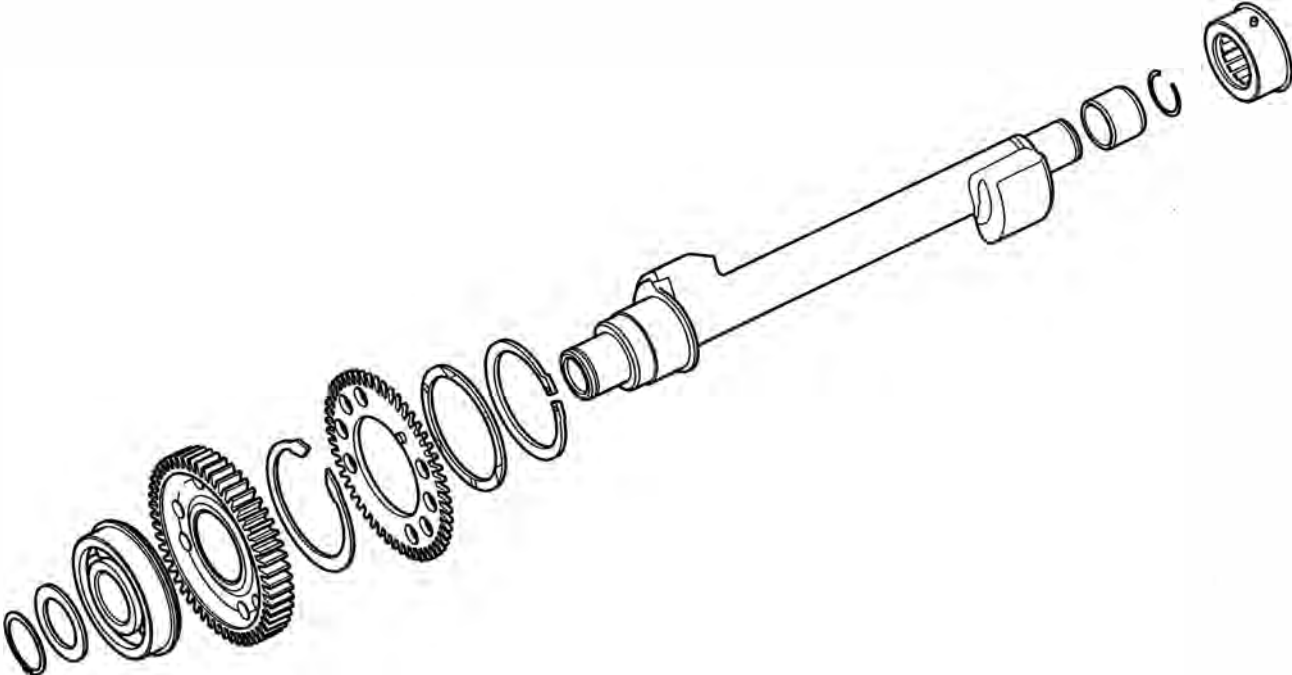

## Balancer

The balancer is fitted to control 'pulsing' within the engine. Without any form of balancer, the engine would 'pulse' each time the crankshaft rotated. This 'pulsing' would be felt as a vibration which would amplify as the engine speed was increased.

The balancer has the effect of a pair of counterbalance weights which create an equal amount of energy in the opposite direction, and at the same time as that produced by the crankshaft, pistons and connecting rods. Because the opposing pulses occur at the same point of crankshaft rotation, and are of an equal magnitude, a state of equilibrium or balance is reached.

## Removal

1. Separate the crankcase halves (see page 5-4).
2. With the crankcase halves separated, lift out the balancer shaft complete with the shaft bearings/circlips.

### Note:

- **As the shaft is released from the crankcase, the backlash eliminator gear will spring out of alignment with the crankshaft.**
3. To remove the left hand bearing, slide the bearing, circlip and bearing sleeve from the balancer shaft. Note the orientation of the bearing prior to removal.
  4. To remove the right hand bearing, remove the circlip and washer, and, using a press and press bars remove the bearing race from the shaft, ensuring the inner bearing race is supported. Note the orientation of the bearing prior to removal. **DO NOT** remove the drive gear from the shaft.

5. To strip the backlash eliminator from the drive gear, release the circlip and remove the wave-washer, backlash gear and spring.

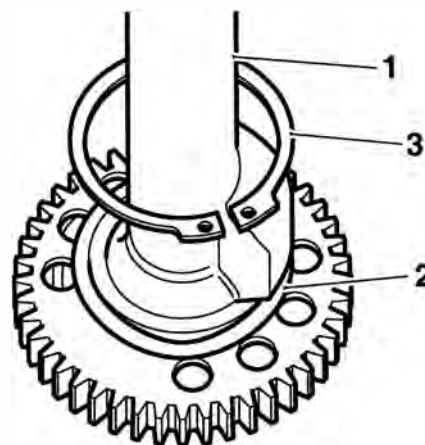

cdon

1. Balancer shaft
2. Wave washer
3. Circlip

## Inspection

1. Inspect all gears for chipped or missing teeth.
2. Inspect all bearings for signs of overheating (blue discolouration), seized or damaged rollers, and any other damage.
3. Inspect the backlash spring for deformities, damage etc.
4. Inspect the gear teeth for overheating (blue discolouration).

### Warning

When using a press, always wear overalls, eye face and hand protection. Objects such as bearings frequently break-up under load and the debris caused during break-up may cause damage and injury to unprotected parts of the body.

Never wear loose clothing, which could become trapped in the press and cause crushing injury to the hand, arms or other parts of the anatomy.

### Caution

Do not remove the drive gear from the balancer shaft. The drive gear is aligned to the shaft. If the balancer and drive gear are not correctly aligned, severe engine vibration will occur leading to damage to components.

# Balancer

## Assembly/Installation

### Note:

- Before assembling the backlash gear to the balancer shaft, lubricate all contact surfaces of the balancer drive gear, backlash spring and backlash gear with a 50/50 solution of engine oil and molybdenum disulphide grease.

1. If the backlash gear was disassembled, fit the backlash spring over the shaft and position to the balancer drive gear, positioning the spring ends on either side of the peg.
2. Fit the backlash gear, ensuring its peg is located anti-clockwise (viewed from the left hand bearing end of the shaft) of the balancer gear peg and also between the spring ends.

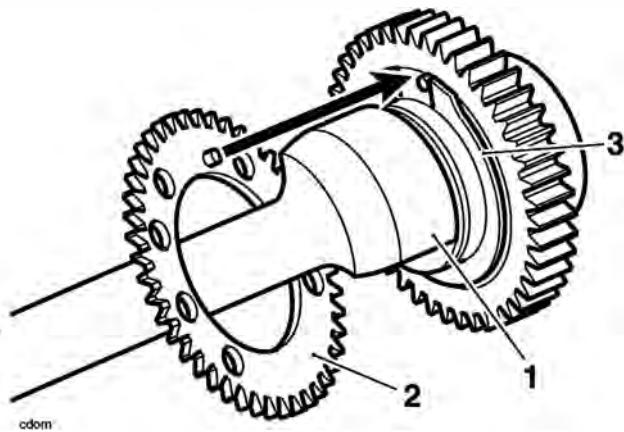

1. Balancer shaft
2. Backlash gear
3. Backlash spring

3. Fit the wave washer and secure all components in position with the circlip.

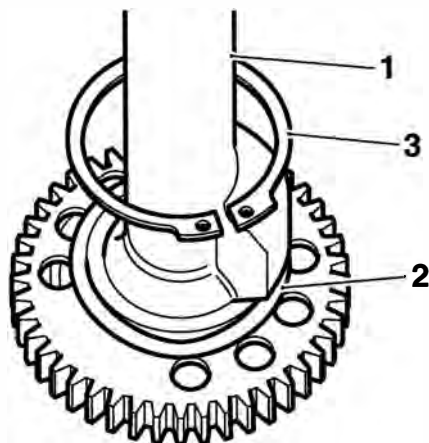

1. Balancer shaft
2. Wave washer
3. Circlip

4. Using a press and press bars, fit the right hand bearing to the shaft, with the circlip positioned nearest to the drive gear. Ensure the inner race of the bearing is supported when installing the bearing.

### Warning

When using a press, always wear overalls, eye face and hand protection. Objects such as bearings frequently break-up under load and the debris caused during break-up may cause damage and injury to unprotected parts of the body.

Never wear loose clothing, which could become trapped in the press and cause crushing injury to the hand, arms or other parts of the anatomy.

5. Refit the washer and a new circlip to the shaft.
6. Lubricate and fit the left hand bearing and install a new circlip in the same orientation as noted prior to removal.

### Note:

- Prior to installation in the crankcase, it is essential that the markings on the backlash eliminator and drive gears are brought into alignment against the tension of the spring. This will facilitate correct positioning of the balancer in relation to the crankshaft when both are installed in the crankcase.

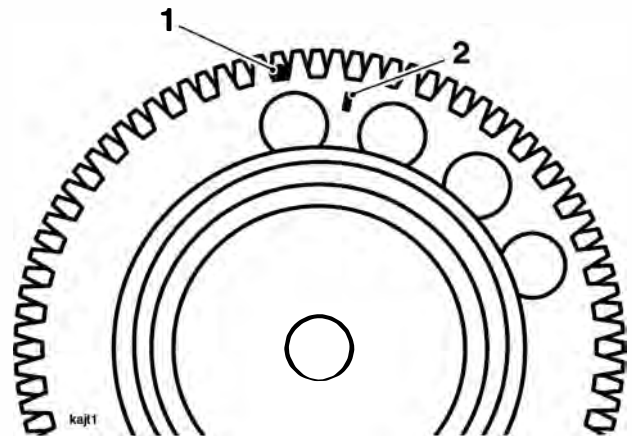

1. Drive gear 'dot'
2. Backlash gear line

7. Using tool T3880156, bring the backlash and drive gear marks into alignment against the backlash spring as follows:

- Engage the peg of tool T3880156 into a tooth of the backlash gear. Rotate the backlash gear against the spring until the marks align.

**Note:**

- **When in alignment, the line on the backlash gear must be located directly above the drive gear tooth marked with a 'dot'.**
  - **Since the drive gear 'dot' cannot be seen when the backlash gear is in alignment, always mark the 'dot'-marked gear tooth with a paint mark in order that it can always be identified.**
8. Secure the backlash gear in position with the fixture supplied with the tool by placing the fixture pegs across two gear teeth (ensure that the fixture will not be in the way when assembling the balancer to the crank).

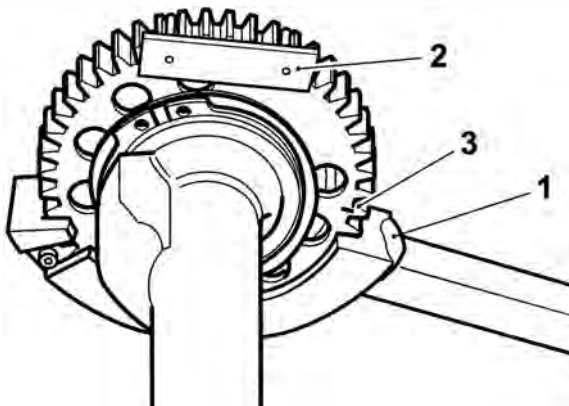

cdon

1. Tool T3880156
2. Securing fixture
3. Balancer backlash gear marking



## Caution

If the balancer and crankshaft are not correctly aligned, severe engine vibration will occur leading to damage to components.

9. With the drive and backlash eliminator gears still correctly aligned, locate the balancer to the crankcase. Align the balancer gears and crankshaft as shown in the illustration below.

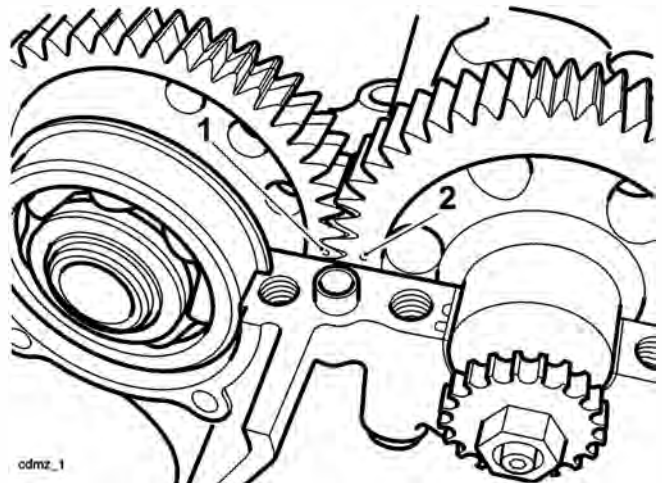

odmz\_1

1. Balancer gear marking
2. Crankshaft markings

10. Ensure that the right hand bearing circlip and dowel locate correctly in the corresponding groove in the crankcase.

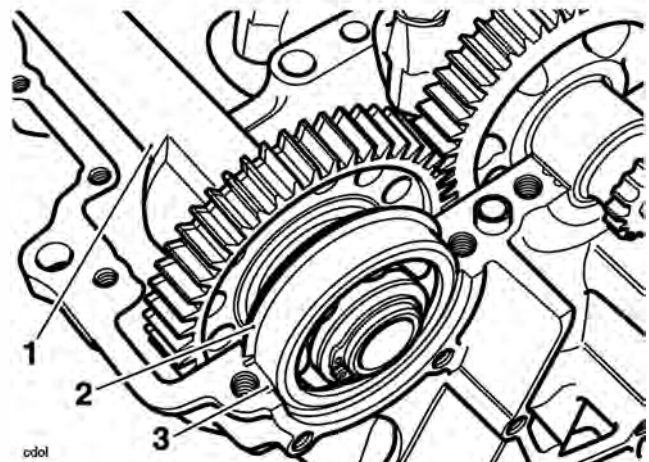

pdol

1. Balancer shaft (right hand bearing)
2. Circlip
3. Dowel

## Balancer

---

11. Ensure that the left hand bearing circlip and dowel locate correctly in the corresponding groove in the crankcase

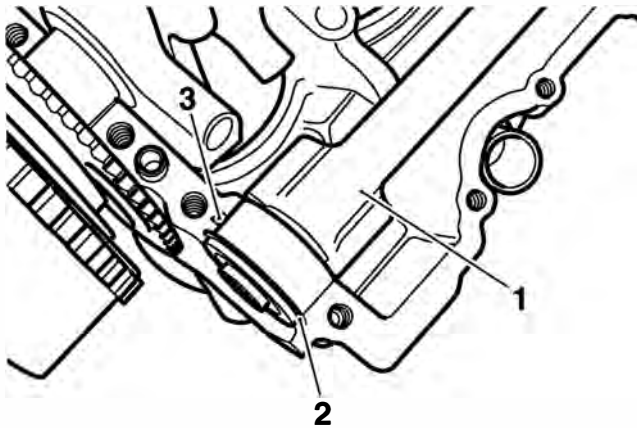

cdok

1. Balancer shaft (left hand bearing)
2. Circlip
3. Dowel

12. Remove the securing fixture.
13. Check that the balancer and crankshaft are correctly aligned before continuing to assemble the crankcase halves.
14. Assemble the crankcase halves (see page 5-4).



# 7 Transmission

## Table of Contents

Exploded View - Input and Output Shafts .....	7.2
Exploded View - Sprag Clutch and Starter Gears .....	7.3
Exploded View - Gear Selectors and Drum .....	7.4
Exploded View - Gear Change Mechanism .....	7.5
Selector Shaft .....	7.6
Removal .....	7.6
Installation .....	7.6
Selector Forks and Drum .....	7.7
Removal .....	7.7
Inspection .....	7.8
Installation .....	7.9
Input and Output Shafts Assemblies .....	7.10
Removal .....	7.10
Installation .....	7.11
Input Shaft .....	7.12
Disassembly .....	7.12
Inspection .....	7.13
Exploded View - Input Shaft .....	7.14
Assembly .....	7.15
Output Shaft .....	7.17
Disassembly .....	7.17
Inspection .....	7.17
Exploded View - Output Shaft .....	7.18
Assembly .....	7.19
Starter Drive Gears/Sprag Clutch .....	7.21
Removal .....	7.21
Inspection .....	7.21
Installation .....	7.22

# Transmission

## Exploded View - Input and Output Shafts

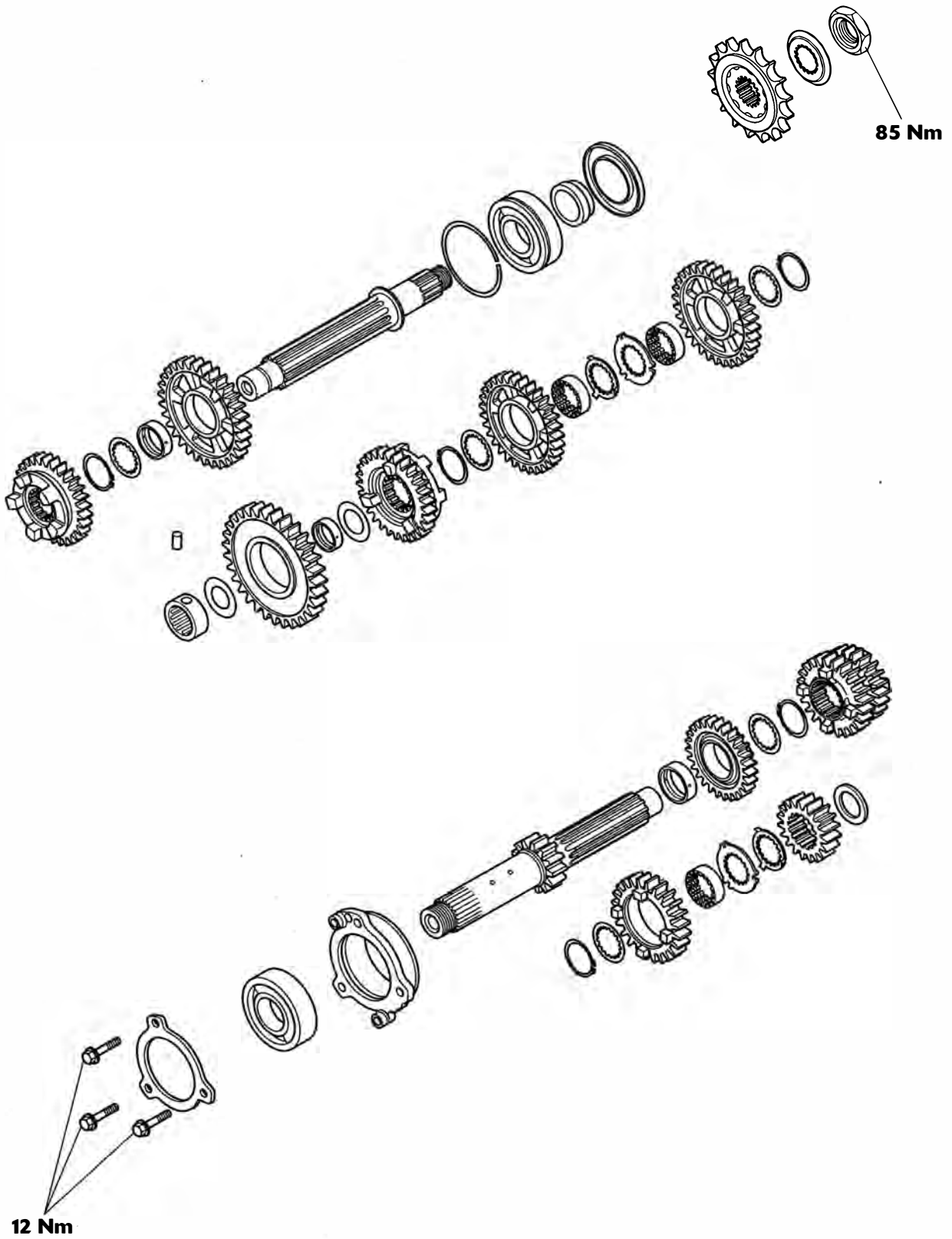

Exploded View - Sprag Clutch and Starter Gears

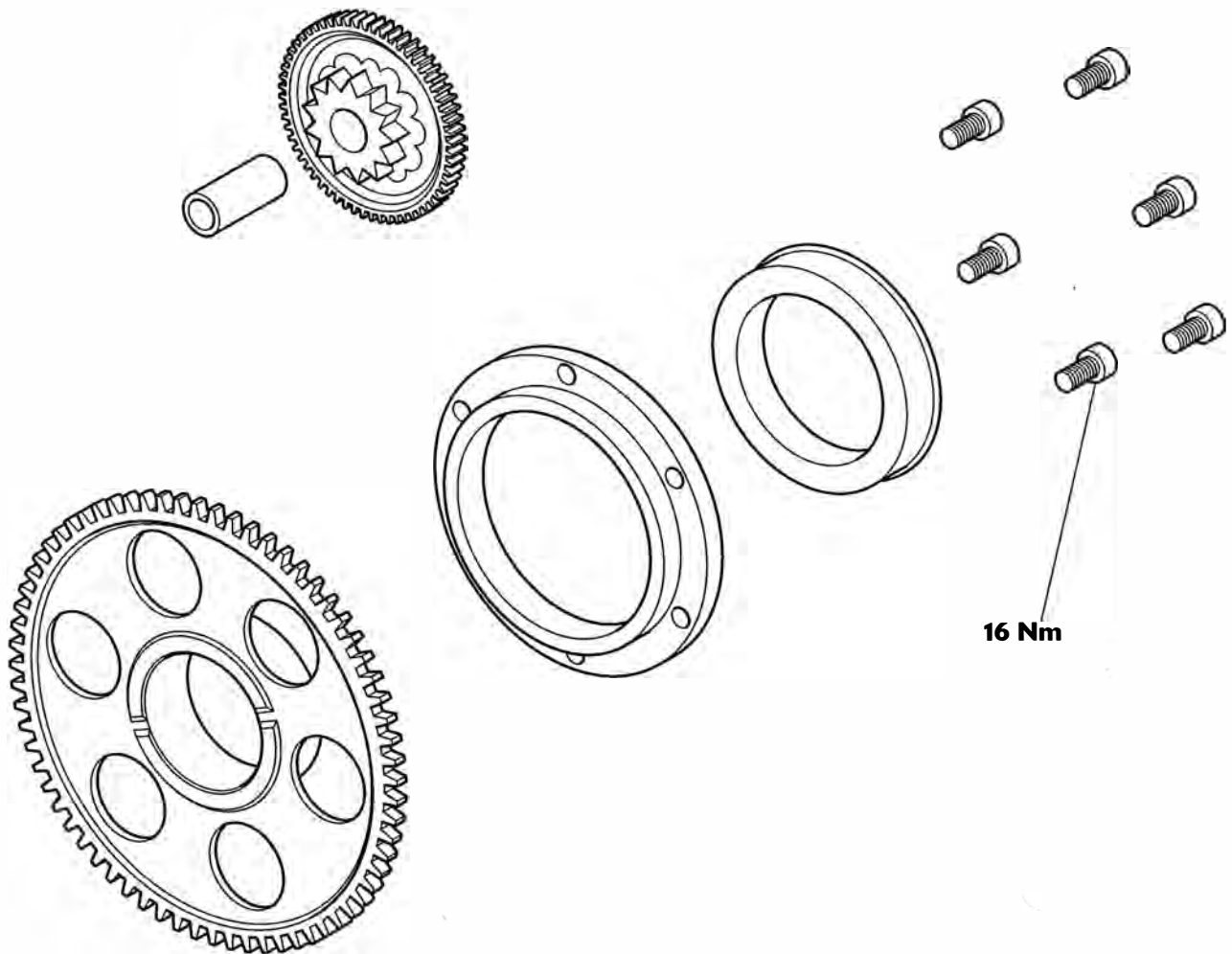

# Transmission

## Exploded View - Gear Selectors and Drum

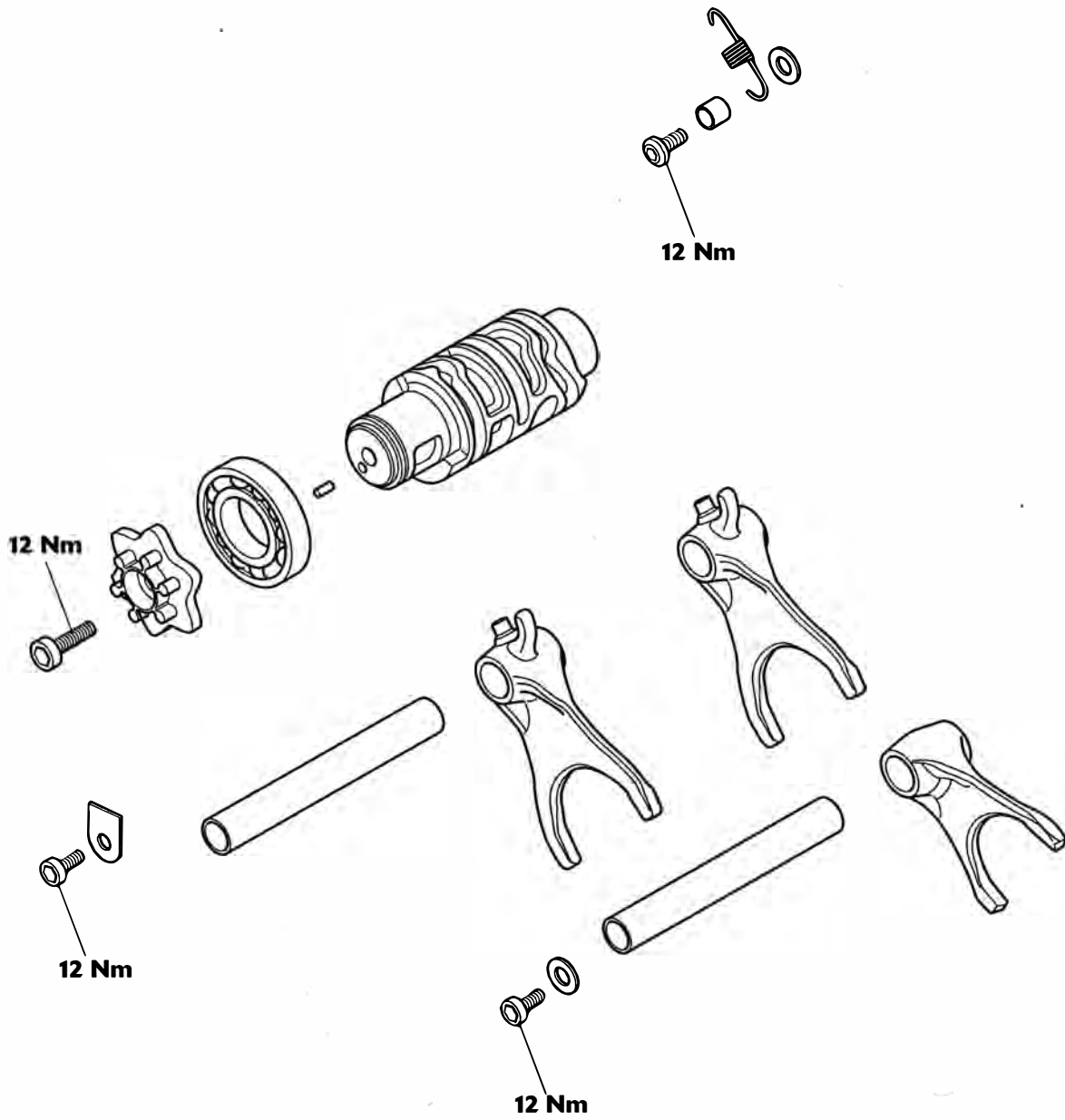

Exploded View - Gear Change Mechanism

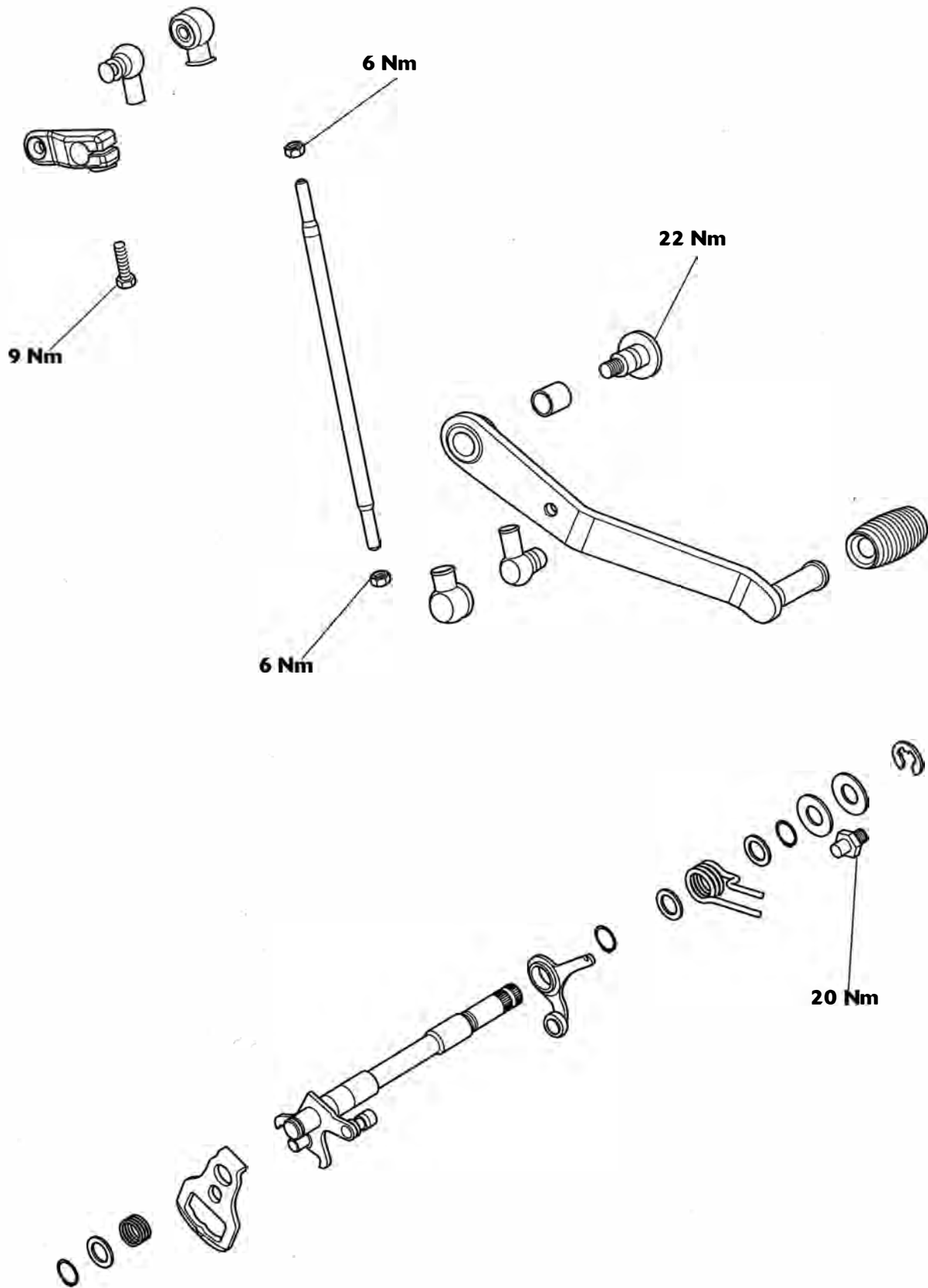

# Transmission

## Selector Shaft

### Removal

1. Note the position and orientation of the gear pedal crank in relation to the shaft, then remove the crank.
2. Remove the E-clip and washer from the gear pedal end of the gear change shaft.

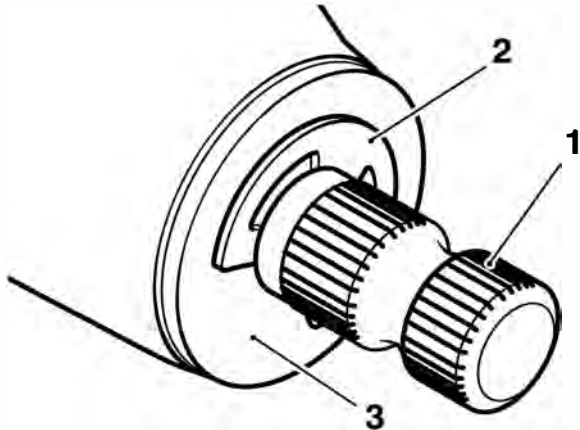

- 1. Gear change shaft
- 2. E-clip
- 3. Washer

3. Remove the clutch (see page 4-6).
4. Un-hook the spring from the detent arm.
5. Withdraw the gear change shaft and detent arm from the clutch end of the crankcase.

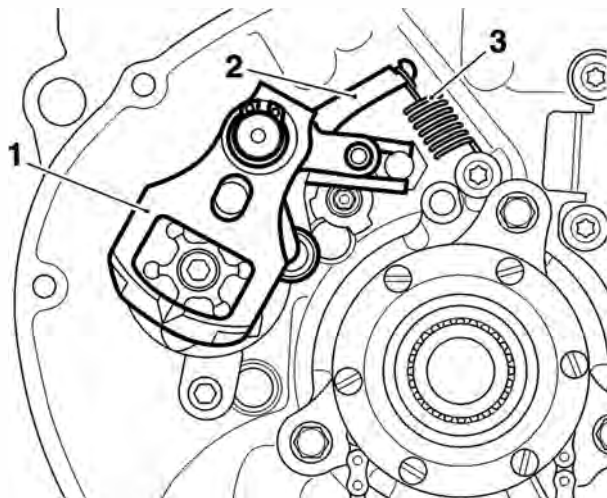

- 1. Gear change shaft
- 2. Detent arm
- 3. Detent arm spring

6. Collect the detent spring.

### Installation

7. Rotate the selector drum to the neutral position.

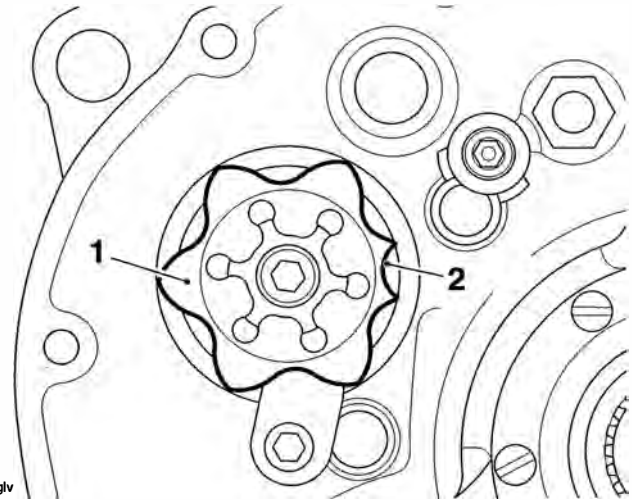

- 1. Detent wheel
- 2. Neutral position

8. Using grease to NLGI 2 specification, lubricate the lip of the seal on the gear change shaft.

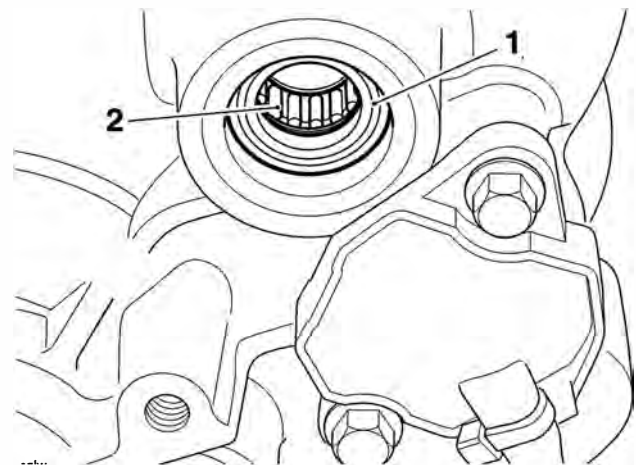

- 1. Gear change shaft seal
- 2. Gear change shaft bearing

### Caution

Take care to avoid damaging the lip of the seal when inserting the gear change shaft into the crankcase. A damaged seal will lead to oil loss and could result in engine damage.

9. Carefully insert the gear pedal end of the shaft through the bearings and lip seal in the crankcase. Support the detent arm bearing clear of the selector

drum as the selector shaft is fully installed, and ensure the selector shaft spring fits either side of the abutment bolt.

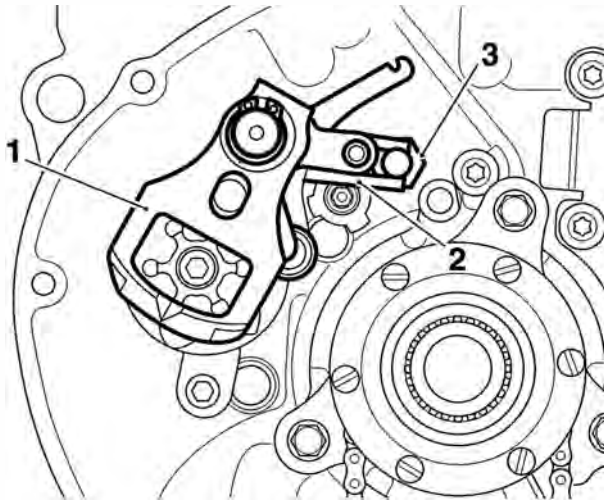

cglf

- 1. Gear change shaft
- 2. Abutment bolt
- 3. Spring

10. Fit the washer and E-dip to the gear pedal end of the gear change shaft.

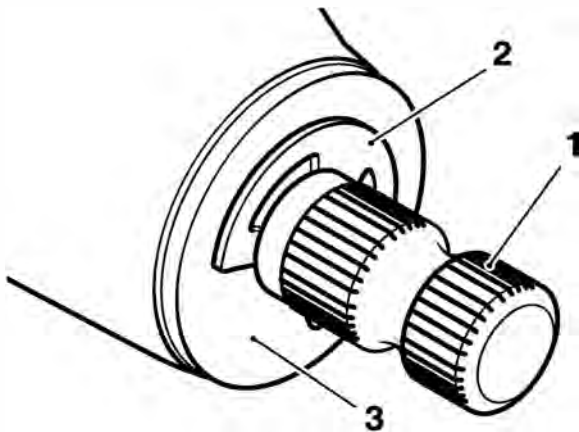

lakh1

- 1. Gear change shaft
- 2. E-clip
- 3. Washer

11. Fit the gear pedal crank to the shaft in the same orientation as noted prior to removal. Ensure the 'dot' mark on the shaft aligns with the split line on the gear pedal crank. Tighten the fixing to **9 Nm**.
12. Refit the spring to the detent arm.
13. Refit the clutch (see page 4-10).

## Selector Forks and Drum

### Removal

1. Remove the engine from the frame (see page 9-3).
2. Separate the two halves of the crankcase (see page 5-4).
3. Remove the output shaft from the crankcase (see page 7-10).
4. Remove the selector shaft (see page 7-6).
5. Remove and discard the two selector fork shaft retaining fixings, noting the position of the washer and the selector drum keeper plate.

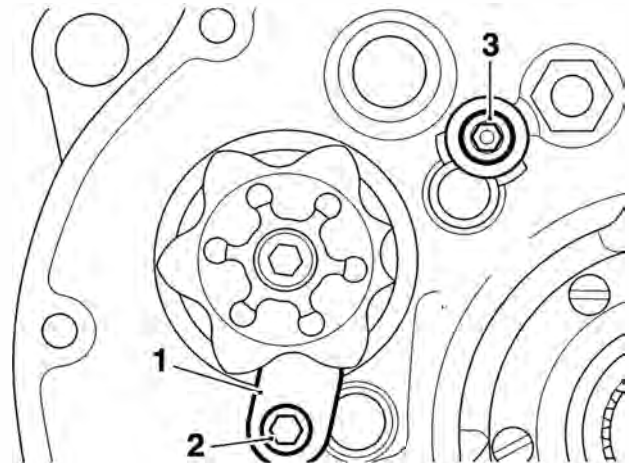

- 1. Selector drum keeper plate
- 2. Output selector fork shaft fixing
- 3. Input selector fork shaft fixing and washer



### Caution

The two output shaft selector forks can be fitted incorrectly. Ensure the position and orientation of the selector forks are marked prior to removal. Incorrect fitting of the selector forks will cause gearbox damage.

# Transmission

6. Noting the positions of the selector forks, slide the output selector shaft from the crankcase in the direction of the clutch. Collect the two selector forks as they are released by the selector fork shaft.

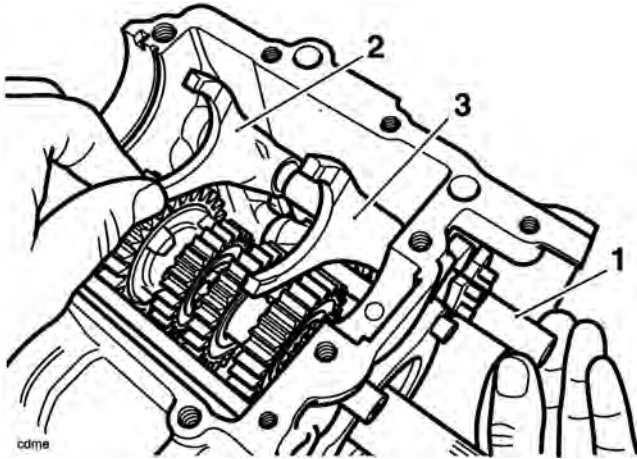

- 1. Output selector shaft
- 2. Sixth gear selector fork
- 3. Fifth gear selector fork

7. Noting the position of the selector fork, remove the input selector shaft, leaving the selector fork in the gearbox.

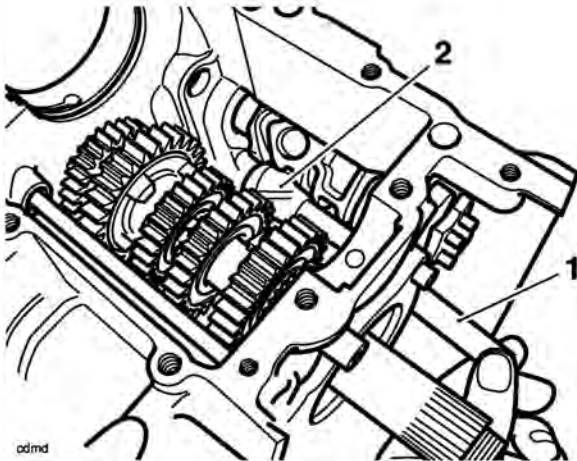

- 1. Input selector shaft
- 2. Selector fork

8. Remove the gear position sensor.

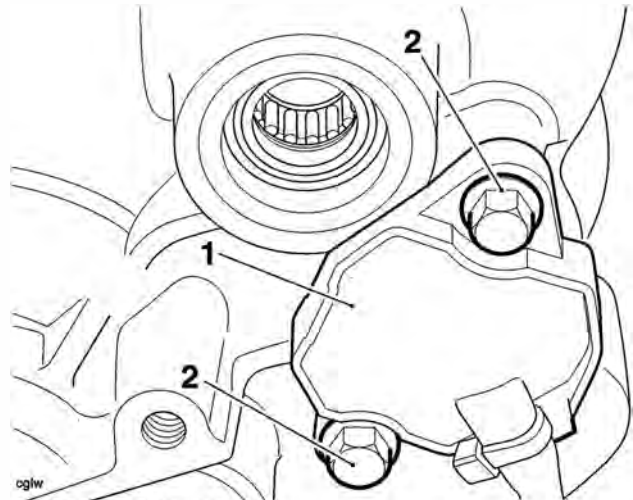

- 1. Gear position sensor
- 2. Fixings

9. Withdraw the selector drum from within the crankcase.

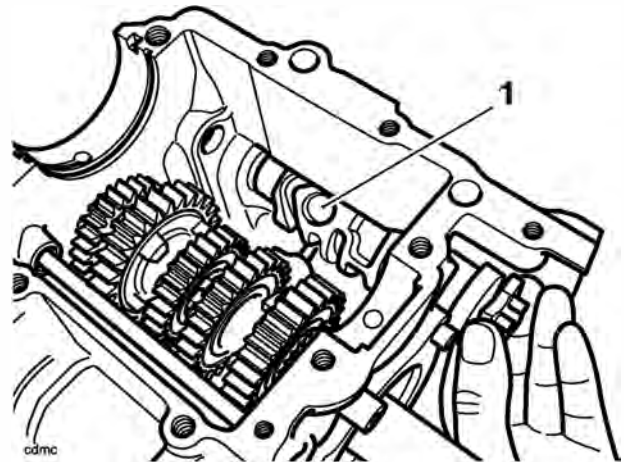

- 1. Selector drum removal

10. Collect the input shaft selector fork from the crankcase.

## Inspection

1. Examine all components for damage and/or wear, paying particular attention to the selector forks and selector drum. Replace any parts that are damaged and/or worn.

### Gear selector fork thickness

Standard	5.90 - 6.00 mm
Service limit	5.80 mm

### Gear selector groove width

Standard	6.10 - 6.17 mm
Service limit	6.27 mm



## Selector fork to groove clearance

Service limit	0.47 mm max
---------------	-------------

- Examine the gear change shaft seal for damage and/or wear. Replace the seal if damaged and/or worn.

## Installation

- Position the input shaft selector fork into the crankcase, locating the forks into the selector groove on the input shaft. Ensure the fork is fitted in the position noted during removal.

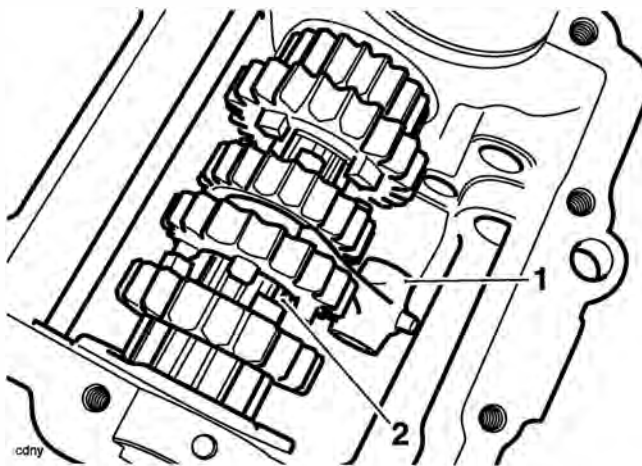

- Input shaft selector fork
- Input shaft

- Using clean engine oil, lubricate the selector drum bearings. Lubricate the selector drum tracks with a 50/50 solution of engine oil and molybdenum disulphide grease.
- Position the selector drum into the crankcase.

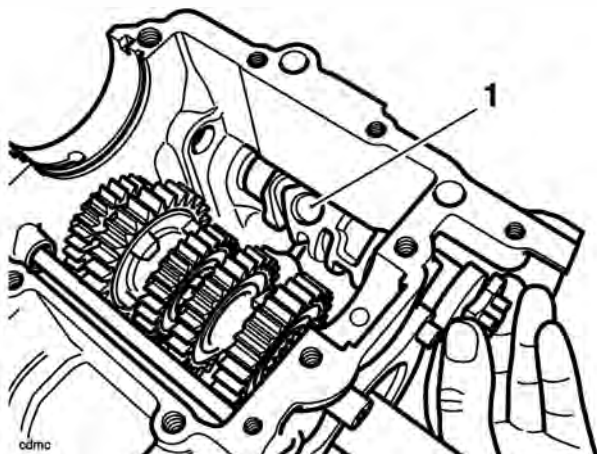

- Selector drum

- Refit the gear position sensor, ensuring the pin on the sensor engages in the hole selector drum. Tighten the fixings to **5 Nm**.

- Rotate the selector drum and ensure a smooth movement. Rectify as necessary.



## Caution

The selector forks can be fitted incorrectly. Ensure the position and orientation of the selector forks are the same as noted during removal. Incorrect fitting of the selector forks will cause gearbox damage.

- Push the input selector shaft into the crankcase from the clutch end. As the shaft is inserted locate the selector fork onto the shaft. Ensure the fork is fitted in the position noted during removal, and the pin on the fork engages in the track in the drum.

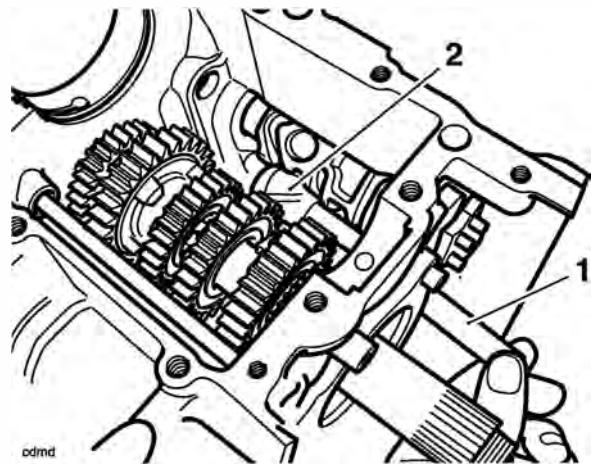

- Input selector shaft
- Selector fork

- Push the output selector shaft into the crankcase from the clutch end. As the shaft is inserted, locate the selector forks. Ensure the fork is fitted in the position noted during removal, and the pin on the fork engages in the track in the drum.

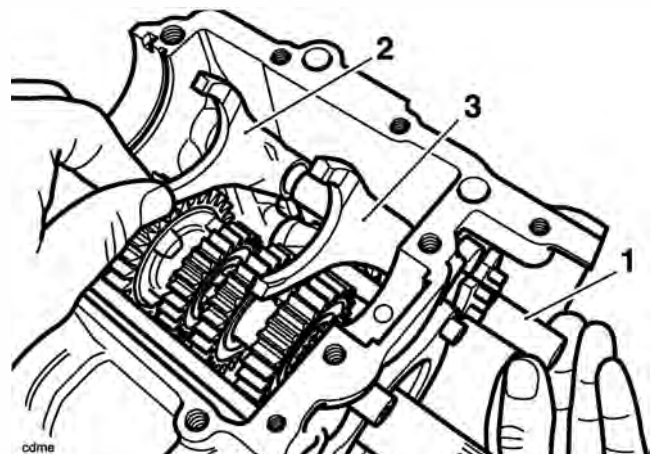

- Output selector shaft
- Sixth gear selector fork
- Fifth gear selector fork

- Fit two new selector shaft retaining fixings, ensuring the washer and the selector drum keeper plate are fitted in the positions noted during removal. Tighten the fixings to **12 Nm**.

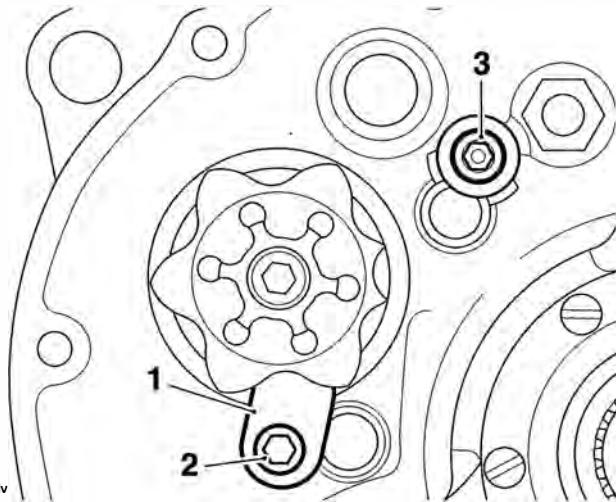

cgiv

**1. Selector drum/shaft keeper plate**

**2. Fixing**

**3. Input selector shaft fixing and washer**

- Refit the selector shaft (see page 7-6).
- Refit the output shaft (see page 7-11).
- Assemble the two halves of the crankcase (see page 5-4).
- Refit the engine to the frame (see page 9-5).

## Input and Output Shafts Assemblies

### Removal

#### Note:

- The input and output shafts may be removed from the upper crankcase after first separating the lower crankcase from the upper.

#### Note:

- The rear needle roller bearing on the input shaft remains in the crankcase on removal of the shaft.

- Remove the engine from the frame (see page 9-3).
- Separate the two halves of the crankcase (see page 5-4).
- Lift the output shaft from the upper crankcase, noting the orientation of each bearing, their circlips and dowels.
- Remove the selector fork shafts and forks (see page 7-7).

#### Note:

- The input shaft bearing housing fixings may not be re-used but should be retained for use during installation of the input shaft.
- Release the three fixings and remove the retaining plate.

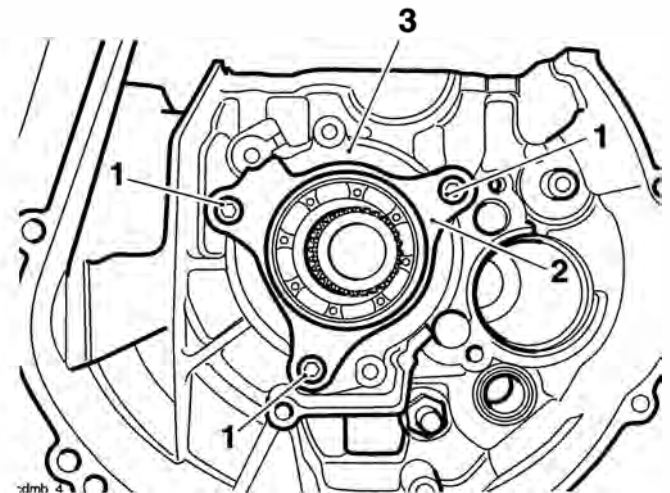

dimh 4

**1. Fixings**

**2. Retaining plate**

**3. Bearing housing**

- Insert two M6 bolts into the two threaded holes at the periphery of the bearing housing. Evenly and progressively tighten both bolts to draw the bearing housing and input shaft from the crankcase.

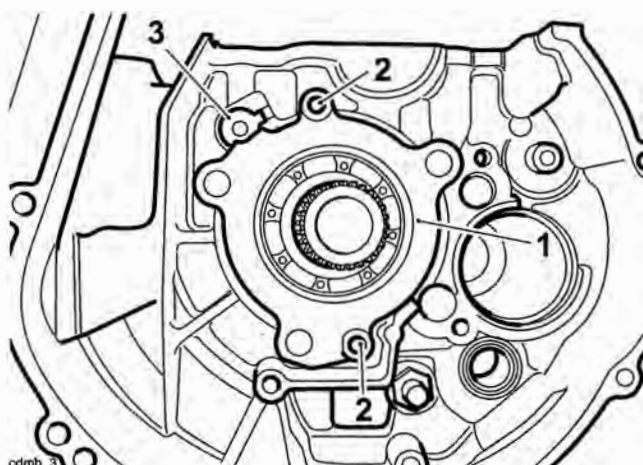

- Bearing housing**
- M6 threaded holes**
- Transmission oil tube**

- If required, the transmission oil tube can now be removed. Remove and discard the three oil tube O-rings.

## Installation

- If removed, check the transmission oil tube for blockages and contamination. Carefully fit new O-rings to the transmission oil tube and insert the tube into the crankcase, ensuring the tag on the tube locates in the slot in the crankcase.
- Locate the input shaft to the upper crankcase, installing it through the aperture for the bearing housing.
- Fit the bearing housing into the aperture, by hand, as deeply as possible.

- Using the old fixings, evenly and progressively tighten them to draw the bearing housing into the upper crankcase until fully home. Remove and discard the fixings.

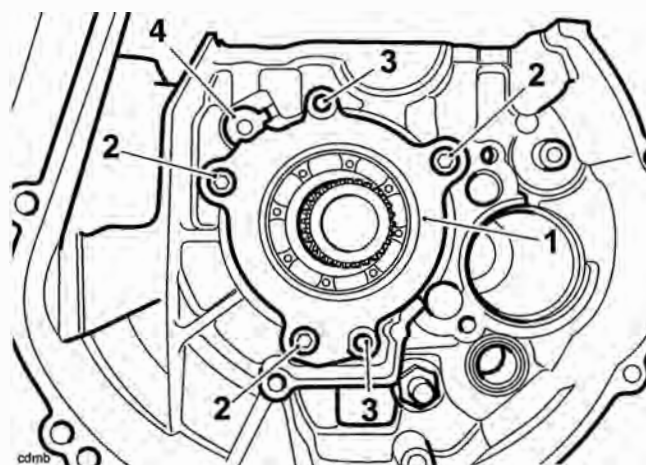

- Bearing housing**
- Fixings**
- M6 threaded holes**
- Transmission oil tube**

- Fit the retaining plate. Install new fixings and tighten to **12 Nm**.

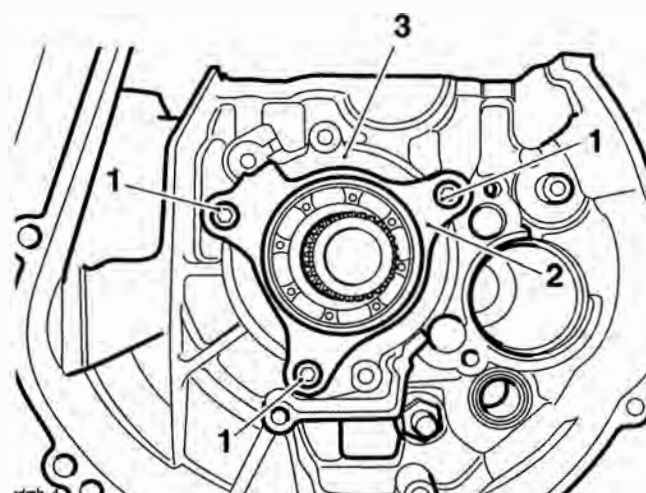

- Fixings**
- Retaining plate**
- Bearing housing**

- Refit the selectors and shafts (see page 7-9).

# Transmission

7. Refit the output shaft to the crankcase ensuring the snap-ring locates in the corresponding groove in the crankcase, and the dowel locates in the slot in the upper crankcase.
8. Ensure the output shaft seal aligns with its recess in the crankcase.

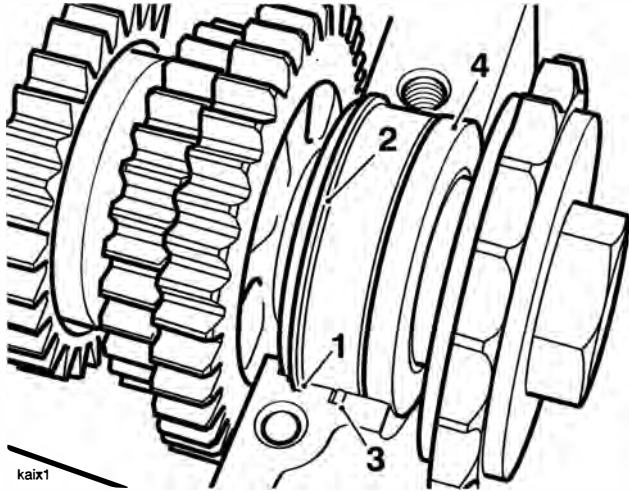

1. Groove in crankcase
2. Snap ring
3. Dowel
4. Seal

9. Ensure the hole in the output shaft needle roller bearing outer race is positioned to locate onto the dowel provided in the upper crankcase. Ensure the selector forks are located in the grooves in the output gears.

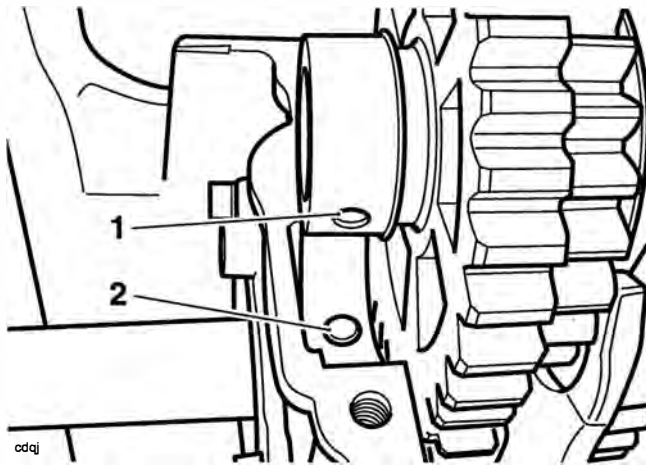

1. Roller bearing
2. Dowel

10. Assemble the two halves of the crankcase (see page 5-4).
11. Refit the engine to the frame (see page 9-5).

## Input Shaft

### Disassembly

#### Note:

- The numbers in brackets in the following text refer to the exploded view on page 7-14.

Working from the opposite end to where the clutch assembly is fitted, dismantle the input shaft as follows:

1. Slide off the plain thrust washer (1).
2. Mark one side of second gear to denote its correct orientation. Remove second gear (2).
3. Remove the splined lock washers (3 and 4), noting their position.
4. Mark one side of sixth gear to denote its correct orientation. Remove sixth gear (6), complete with the splined bush (5) which runs inside the gear.
5. Remove the splined thrust washer (7) from in front of the circlip between sixth and third/fourth gear.
6. Remove and discard the circlip (8) from the shaft.
7. Mark one side of the combined third/fourth gear to denote its correct orientation. Remove the combined third/fourth gear (9).
8. Remove and discard the circlip (10) from in front of fifth gear.
9. Remove the splined thrust washer (11) adjacent to fifth gear.
10. Mark one side of fifth gear to denote its correct orientation. Remove fifth gear (12), complete with the plain bush (13) which runs inside the gear.

#### Note:

- Unless the bearing at the clutch end of the input shaft is damaged or worn, it is not normally necessary to remove it from the shaft. The bearing is pressed onto the shaft and is also pressed into its housing. The bearing and housing are removed from the shaft together and are then separated.



### Warning

When using a press, always wear overalls, eye face and hand protection. Objects such as bearings frequently break-up under load and the debris caused during break-up may cause damage and injury to unprotected parts of the body.

Never wear loose clothing, which could become trapped in the press and cause crushing injuries to the hand, arms or other parts of the anatomy.

11. Support the bearing and housing (15 and 16) on press bars, then press the shaft (14) through the bearing and housing as shown below.

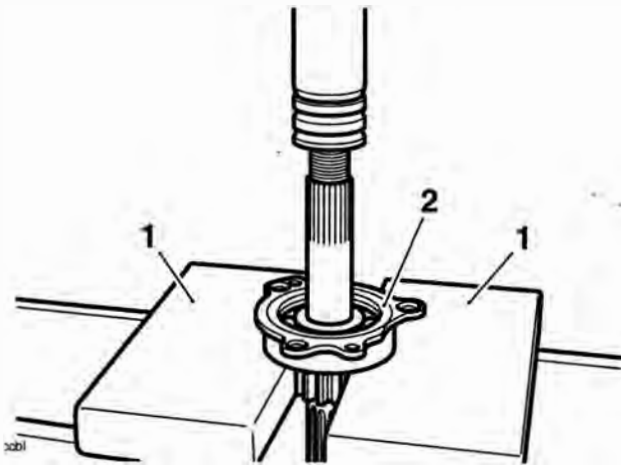

1. Press bars
2. Bearing/housing

12. Support the outer circumference of the bearing housing on press bars, then press the bearing through the housing.

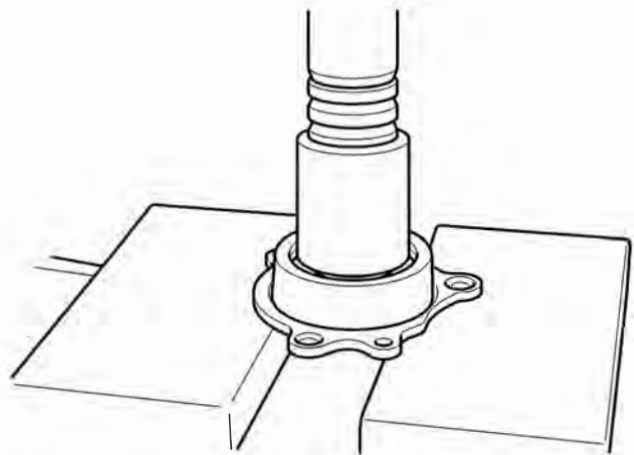

**Pressing out the Bearing**

## Inspection

1. Examine all gears, bearings and bushes and thrust washers for damage, distortion, chipped teeth and wear beyond the service limits. Replace all defective components and always use new circlips to assemble the shaft.
2. Thoroughly clean the bearing housing and inspect for damage, scoring and cracks. Replace the housing if necessary.

# Transmission

## Exploded View - Input Shaft

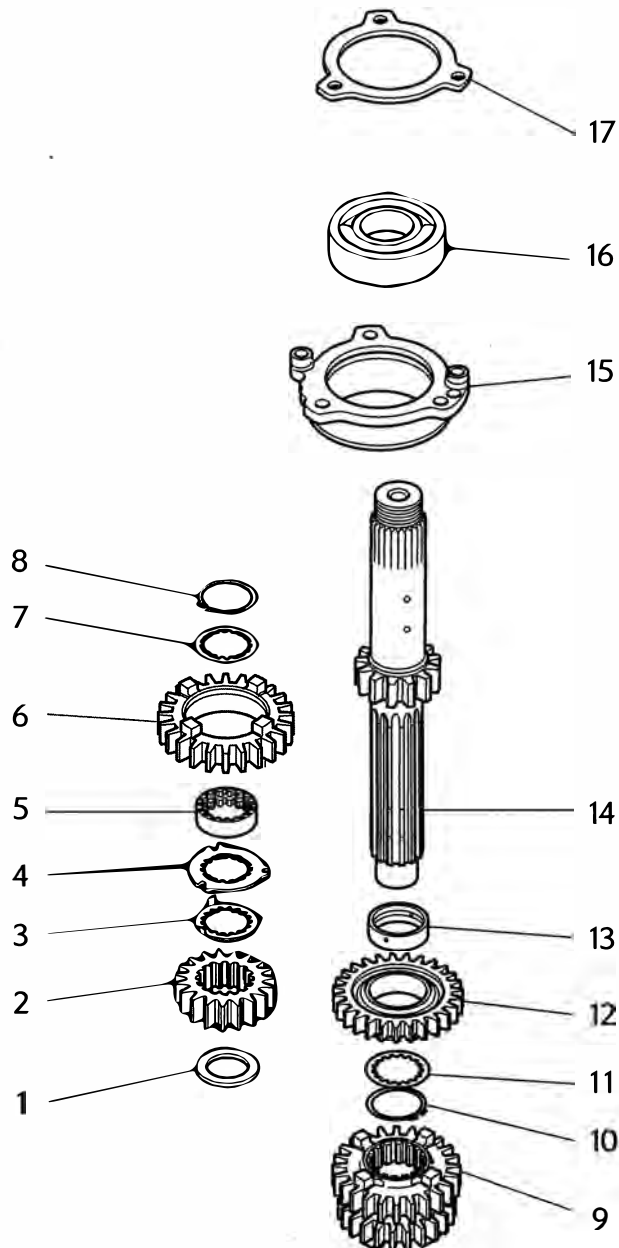

- 1. Thrust washer
- 2. Second gear
- 3. Lock washer
- 4. Splined washer
- 5. Splined bush
- 6. Sixth gear
- 7. Splined thrust washer
- 8. Circlip
- 9. Third/fourth gear

- 10. Circlip
- 11. Splined thrust washer
- 12. Fifth gear
- 13. Plain bush
- 14. Input shaft
- 15. Bearing housing
- 16. Bearing
- 17. Bearing retainer

## Assembly

### Note:

- The numbers in brackets in the following text refer to the exploded view on page 7-14.
- Lubricate each gear, thrust washer and bush with clean engine oil during assembly.

### Warning

When using a press, always wear overalls, eye face and hand protection. Objects such as bearings frequently break-up under load and the debris caused during break-up may cause damage and injury to unprotected parts of the body.

Never wear loose clothing, which could become trapped in the press and cause crushing injuries to the hand, arms or other parts of the anatomy.

### Caution

Bushes and gears with oil holes must always be MISALIGNED with the corresponding oil holes in the input shaft. Reduced oil pressure and gear lubrication may result from alignment of the oil holes, which would cause premature wear of engine and transmission components.

### Caution

Removing the input shaft bearing from the shaft and its housing will damage the bearing. Never re-use removed bearings as use of damaged or weakened components could lead to engine and transmission damage. Also, check for damage to the housing itself.

1. Position the bearing to the housing.

### Caution

Press only on the bearing outer race to prevent bearing damage.

2. Support the housing on press bars as shown below and press the bearing fully into the housing in the direction of the arrow.

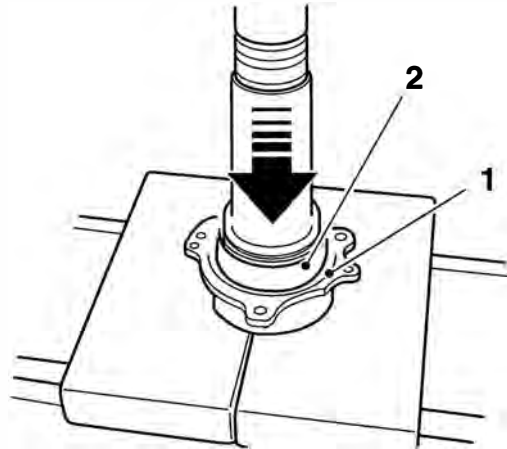

1. Bearing housing
2. Bearing

### Caution

Press only on the bearing inner race to prevent bearing damage.

3. Locate the bearing and housing to the input shaft. Carefully support the shaft on the press bed, and using a suitable sleeve over the input shaft to ensure the bearing is pressed only on the inner race, press the bearing onto the shaft.

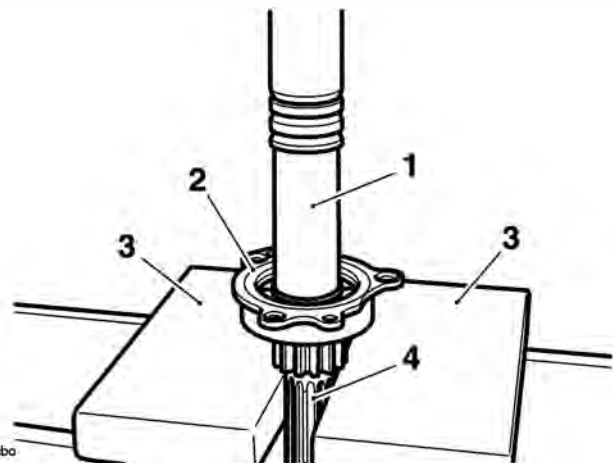

1. Sleeve
2. Bearing/housing
3. Press bars
4. Input shaft

4. Fit the plain bush (13) to the shaft.
5. Fit fifth gear (12) to the input shaft as noted during disassembly, with the dog teeth pointing away from the input shaft bearing.
6. Slide on the splined thrust washer (11).

# Transmission

- Fit a new circlip (10) to the input shaft ensuring that the clip is located in the circlip groove as shown below.

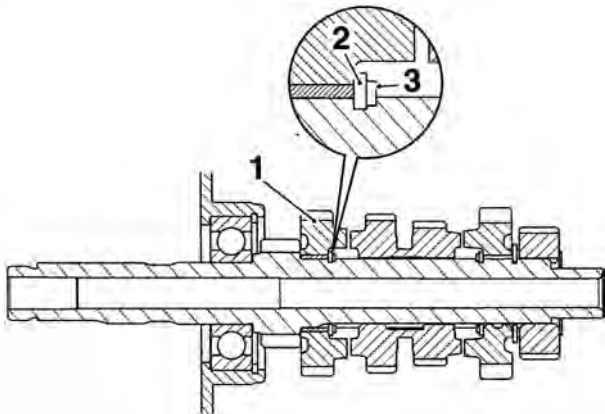

cdmo

- Fifth gear**
- Thrust washer**
- Circlip**

- Fit the combined third/fourth gear (9) as noted during disassembly, with the larger gear facing toward fifth gear. Ensure that the oil hole in the input shaft DOES NOT align with the oil hole in the gear.

## Warning

If the oil hole in the third/fourth gear is aligned with the corresponding hole in the input shaft, engine oil pressure and gear lubrication will be reduced. Reduced oil pressure and gear lubrication will cause engine damage and could also lead to engine seizure resulting in loss of motorcycle control and an accident

- Fit a new circlip (8) to the input shaft ensuring that the circlip is located in the circlip groove as shown below.

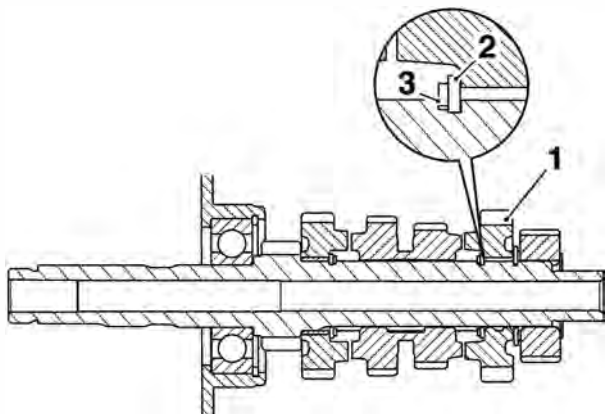

cdmp

- Sixth gear**
- Thrust washer**
- Circlip**

- Fit the splined thrust washer (7) to the input shaft and slide up the shaft until in contact with the circlip.
- Fit the splined bush (5) from sixth gear. Ensure that the oil hole in the input shaft DOES NOT align with the oil hole in the bush.
- Fit sixth gear (6) as noted during disassembly, with the dog teeth facing third/fourth gear.
- Fit the splined and lock washers (4 and 3), ensuring the tabs in the smaller washer (3) locate in the slots in the larger (4) washer.

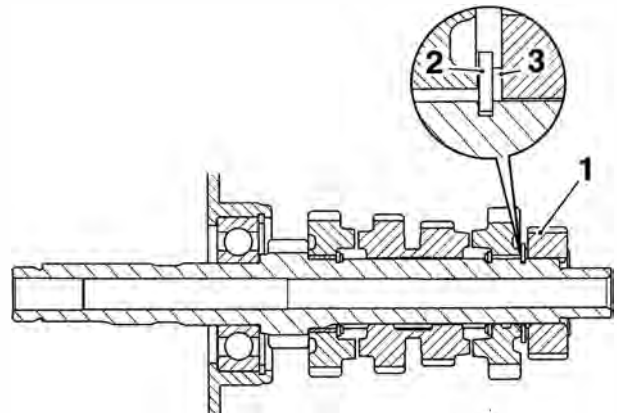

cdmq

- Second gear**
- Large splined lock washer**
- Small splined lock washer**

- Fit second gear (2) to the shaft as noted during disassembly.
- Fit the plain thrust washer (1) adjacent to second gear.



## Output Shaft

### Note:

- **The numbers in brackets in the following text refer to the exploded view on page 7-18.**

Working from the opposite end to the drive sprocket, dismantle the output shaft as follows.

### Disassembly

1. Remove the output shaft bearing (1) and plain thrust washer (2).
2. Mark one side of first gear to denote its correct orientation. Remove first gear (3) from the shaft, complete with the plain bush (4) which runs inside the gear.
3. Remove the plain thrust washer (5).
4. Mark one side of fifth gear to denote its correct orientation. Remove fifth gear (6) from the shaft.
5. Remove the circlip (7) and splined thrust washer (8) from in front of fourth gear.
6. Mark one side of fourth gear to denote its correct orientation. Remove fourth gear (9) complete with the splined bush which runs inside the gear (10).
7. Remove the splined lock washers (11 and 12) noting their positions.
8. Mark one side of third gear to denote its correct orientation. Remove third gear (14) off the shaft complete with the splined bush (13) which runs inside the gear.
9. Remove the splined thrust washer (15).
10. Remove the circlip (16) from in front of sixth gear.
11. Mark one side of sixth gear to denote its correct orientation. Remove sixth gear (17) from the shaft.
12. Remove the circlip (18) from in front of second gear.
13. Remove the splined thrust washer (19).
14. Mark one side of second gear to denote its correct orientation. Remove second gear (21) from the shaft, complete with the plain bush (20) which runs inside the gear.
15. Position the output shaft (22) in a vice with soft jaws fitted. Tighten the vice to prevent the shaft from turning and release the tab washer (28) from the output sprocket nut (29), then release the nut.
16. Remove the output sprocket nut (29), tab washer (28) and sprocket (27).
17. Collect the output shaft seal (26).
18. If it is found necessary to replace the large bearing (24) at the end of the shaft, use a press to remove both the bearing and output shaft sprocket spacer (25) together.



### Warning

When removing the output shaft bearing, always wear overalls, eye, face and hand protection. The bearing races are hardened and are liable to splinter if broken. Debris from broken bearings could cause injury to eyes, face and any unprotected parts of the body.

### Inspection

1. Examine all gears, bearings and bushes and thrust washers for damage, distortion, chipped teeth and wear beyond the service limits. Replace all defective components and always use new circlips, a new output shaft seal and a new sprocket tab washer to assemble the shaft.

# Transmission

## Exploded View - Output Shaft

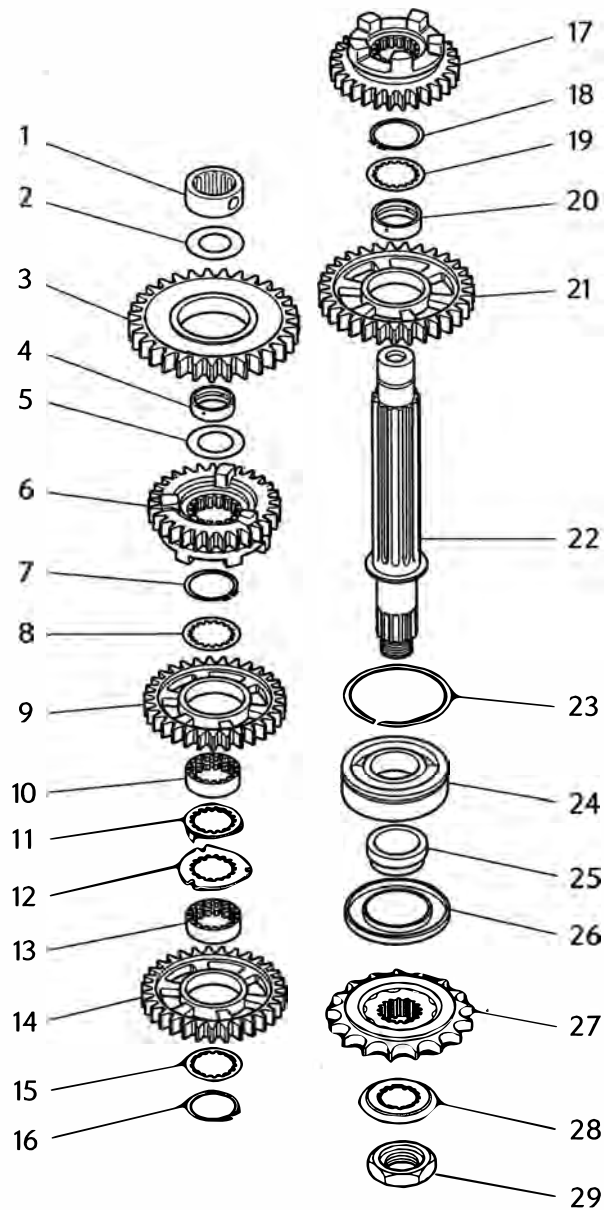

- 1. Bearing
- 2. Thrust washer
- 3. First gear
- 4. Plain bush
- 5. Thrust washer
- 6. Fifth gear
- 7. Circlip
- 8. Splined thrust washer
- 9. Fourth gear
- 10. Splined bush
- 11. Lock washer
- 12. Splined washer
- 13. Splined bush
- 14. Third gear
- 15. Splined washer

- 16. Circlip
- 17. Sixth gear
- 18. Circlip
- 19. Splined thrust washer
- 20. Plain bush
- 21. Second gear
- 22. Output shaft
- 23. Snap ring
- 24. Bearing
- 25. Sprocket spacer
- 26. Output shaft seal
- 27. Output sprocket
- 28. Tab washer
- 29. Output sprocket nut

## Assembly

### Note:

- The numbers in brackets in the following text refer to the exploded view on page 7-18.
- Lubricate each gear and bush with clean engine oil during assembly.

### Warning

When using a press, always wear overalls, eye face and hand protection. Objects such as bearings frequently break-up under load and the debris caused during break-up may cause damage and injury to unprotected parts of the body.

Never wear loose clothing, which could become trapped in the press and cause crushing injuries to the hand, arms or other parts of the anatomy.

### Caution

Bushes and gears with oil holes must always be MISALIGNED with the corresponding oil holes in the output shaft. Reduced oil pressure and gear lubrication may result from alignment of the oil holes, which would cause premature wear of engine and transmission components.

### Caution

Removing the output shaft bearing from the shaft will damage the bearing and snap ring. Never re-use removed bearings or snap rings as use of damaged or weakened components could lead to engine and transmission damage.

### Caution

Press only on the bearing inner race to prevent bearing damage.

1. If removed, working from the output sprocket end of the shaft, fit a new bearing (24) and a new sprocket spacer (25) to the shaft using a press and press bars. Fit the sleeve with the large chamfer facing outwards.

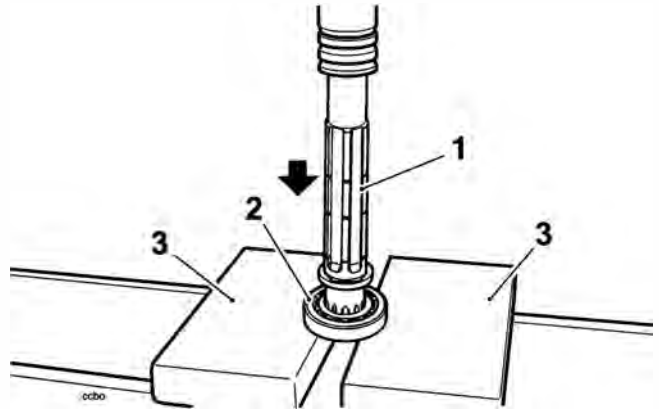

#### 1. Output shaft

#### 2. Bearing

#### 3. Press bars

2. Lubricate and fit a new output shaft seal (26).
3. If removed, transfer the shaft to the vice and secure between soft jaws. Fit the output sprocket (27), new tab washer (28) and nut (29). Tighten the nut to **85 Nm**. Close the tab washer.
4. Withdraw the shaft from the vice and continue to assemble from the opposite end to the output sprocket.
5. Fit the plain bush (20) to the shaft.
6. Locate second gear (21) to the shaft as noted during disassembly, with the large step side facing towards the output sprocket end. Fit the splined thrust washer (19) and retain with a new circlip (18) as shown below.

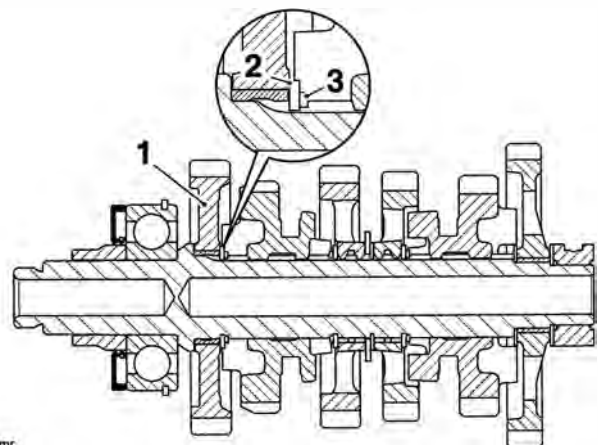

#### 1. Second gear

#### 2. Thrust washer

#### 3. Circlip

# Transmission

7. Fit sixth gear (17) as noted during disassembly, with the selector fork groove facing away from the output sprocket end. Ensure that the oil holes in the gear DO NOT align with the corresponding oil hole in the output shaft.
8. Fit a new circlip (16) to retain third gear. Fit the splined thrust washer (15) to the rear of third gear as shown below.

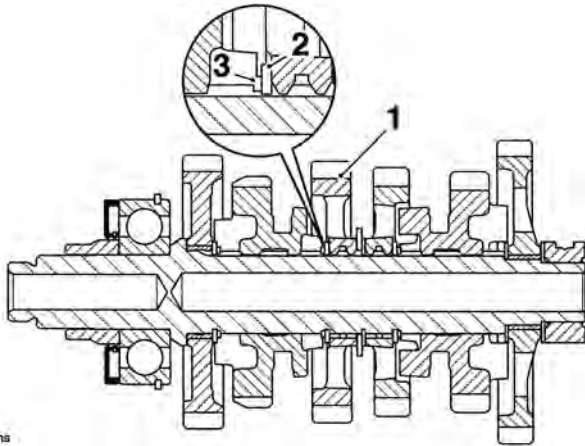

odms

1. Third gear
2. Splined thrust washer
3. Circlip

9. Fit the splined bush (13) for third gear. Ensure that the oil holes in the gear DO NOT align with the corresponding oil hole in the output shaft. Fit third gear (14) to the shaft with the large step side facing away from the output sprocket.
10. Fit the splined lock washers (12 and 11), ensuring the tabs in the smaller washer (11) locate in the slots in the larger washer (12) as shown below.

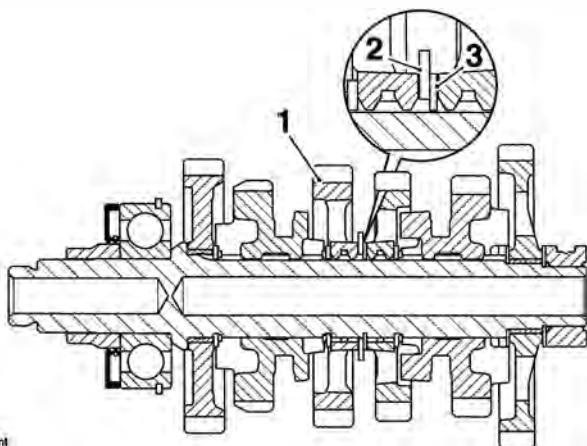

cdmt

1. Third gear
2. Large splined lock washer
3. Small splined lock washer

11. Fit the splined bush (10) from fourth gear. Ensure that the oil holes in the gear DO NOT align with the corresponding oil hole in the output shaft.

12. Fit fourth gear (9) as noted during disassembly, with the larger step side facing towards the output sprocket.
13. Fit the splined thrust washer (8) and retain with a new circlip (7) as shown below.

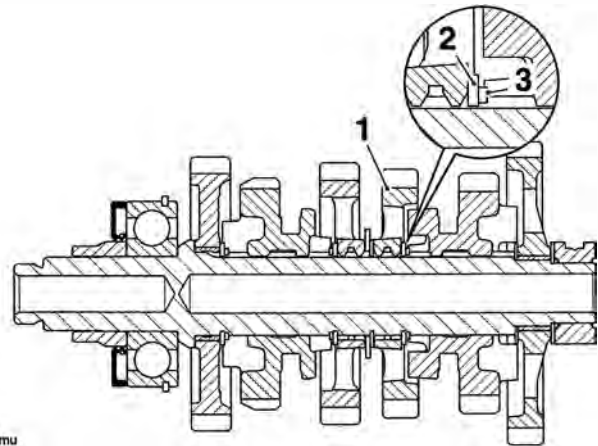

cdmu

1. Fourth gear
2. Splined thrust washer
3. Circlip

14. Fit the fifth gear (6) to the shaft with the groove facing towards the output sprocket. Ensure that the oil holes in the gear DO NOT align with the corresponding oil hole in the output shaft.
15. Fit the first gear thrust washer (5) and plain bush (4).
16. Fit first gear (3) to the shaft as marked during disassembly as shown below.

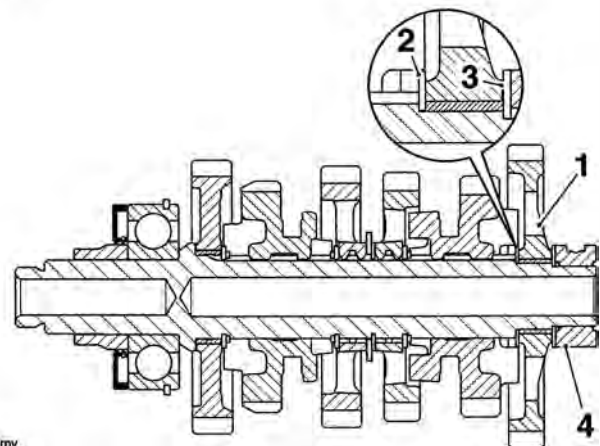

cdmv

1. First gear
2. Thrust washer
3. Thrust washer
4. Needle roller bearing

17. Finally fit the thrust washer (2) and needle roller bearing (1) to the end of the shaft.

## Starter Drive Gears/Sprag Clutch

### Removal

#### Note:

- The sprag clutch may be detached after first removing the rider's seat and the battery (disconnect the negative (black) lead first). The alternator must also be removed. Refer to the relevant sections for removal procedures.

1. Remove the rider's seat (see page 16-13).
2. Disconnect the battery, negative (black) lead first.
3. Release the bolts securing the left hand engine cover. Collect the coolant hose bracket from under the front two bolts.
4. Remove the left hand engine cover and position aside. Discard the 35 mm fixings.

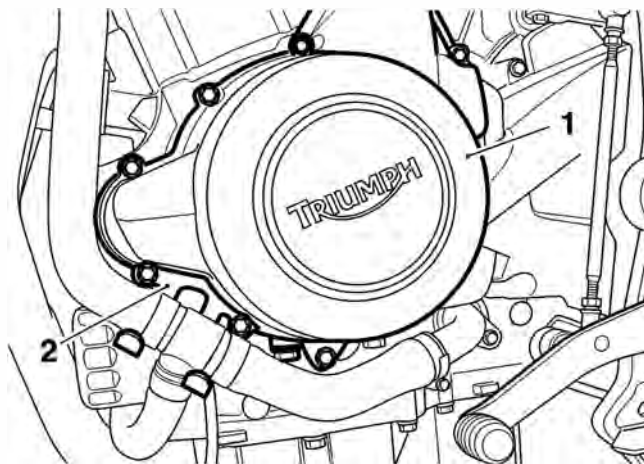

1. Left hand engine cover
2. Coolant hose bracket

5. Withdraw the starter idler gear and shaft, noting the fitted position of the components.

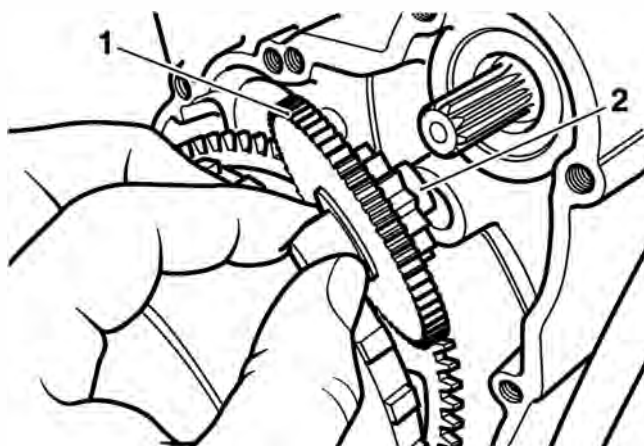

1. Idler gear
2. Idler shaft

6. Remove the alternator rotor (see page 17-19).
7. Withdraw the starter drive gear from the sprag clutch.

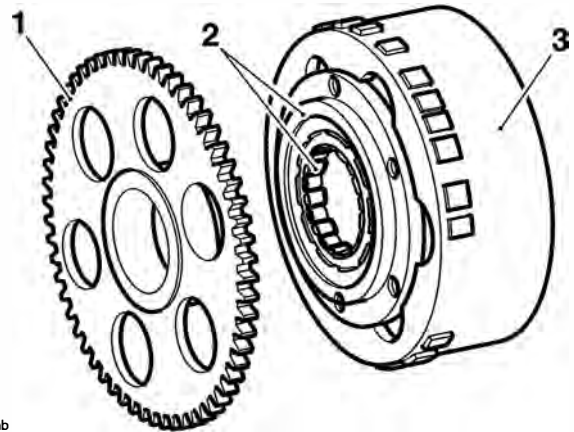

cdnb

1. Starter drive gear
2. Sprag clutch/housing
3. Alternator rotor

8. Remove and discard the fixings securing the sprag clutch housing to the alternator rotor. Withdraw the sprag clutch housing.
9. Remove the sprag clutch from the housing.

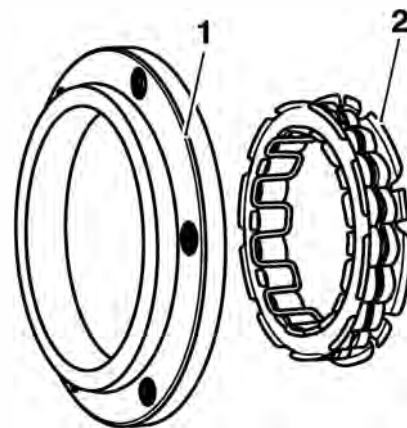

1. Sprag clutch housing
2. Sprag clutch assembly

### Inspection

1. Check the sprag clutch bearings for overheating, wear and/or non-smooth operation. Replace the sprag clutch if overheating, wear and/or non-smooth operation is found.
2. Examine all gears for chipped teeth, overheating (going blue) and for any other damage.

# Transmission

3. With the sprag clutch mounted in the housing, check the sprag clutch for smooth, free movement in one direction only (as indicated by the arrow marked on the sprag clutch body).

## Installation

1. Locate the sprag clutch to the housing as shown below. Push firmly until the lip seats in the recess provided in the housing.

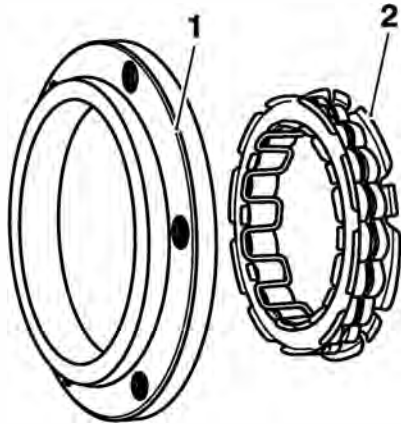

1. Sprag clutch housing
2. Sprag clutch assembly

2. Fit the housing to the alternator rotor.
3. Ensure that the housing is squarely seated and is not jammed on the rotor. Install new fixings.
4. Working in the sequence shown, tighten the bolts to **16 Nm**. Once all six bolts have been tightened, go around again in sequence and recheck each bolt is correctly torqued, if any bolt moves, go around again. Repeatedly check the bolts in sequence until all are correctly torqued and do not move when checked, this will ensure the sprag clutch housing is correctly seated on the rotor.

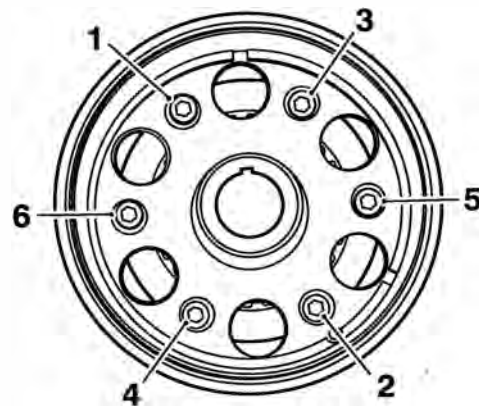

## Bolt Tightening Sequence

5. Fit the starter drive gear to the sprag clutch.

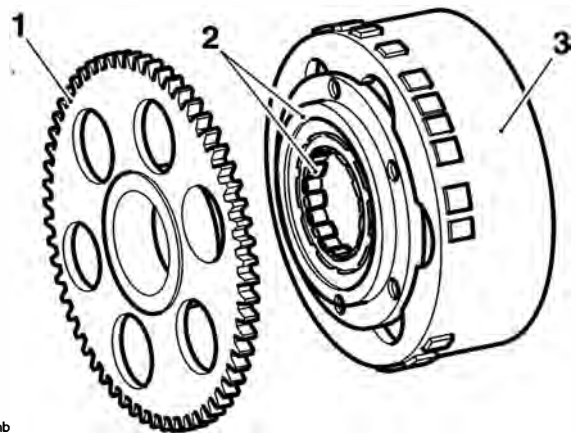

1. Starter drive gear
2. Sprag clutch housing
3. Alternator rotor

6. Refit the alternator rotor (see page 17-20).
7. Lubricate the idler gear shaft with a 50/50 solution of engine oil and molybdenum disulphide grease.
8. Fit the starter idler gear and shaft to the crankcase.

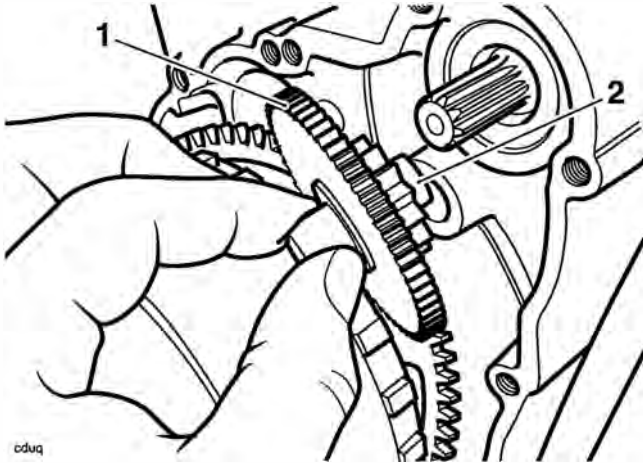

1. Idler gear
2. Idler shaft

9. Thoroughly clean the left hand engine cover.
10. Position a new gasket to the crankcase dowels then refit the left hand engine cover.

11. Refit the bottom hose bracket to the front two bolts. Install the cover bolts, using new 35 mm bolts as noted during removal (the 25 mm bolts may be re-used). Tighten the 25 mm fixings to **8 Nm**, and the 35 mm fixings to **9 Nm**.

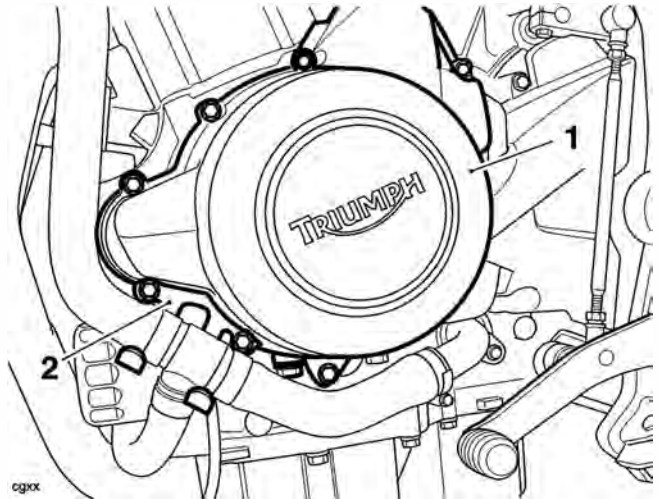

1. Left hand engine cover
2. Coolant hose bracket

12. Reconnect the battery, positive (red) lead first.
13. Refit the rider's seat (see page 16-13).

This page intentionally left blank



# 8 Lubrication

## Table of Contents

Exploded View - Sump.....	8.2
Exploded View - Oil Pump/Water Pump, Gears and Heat Exchanger.....	8.3
Engine Oil Circuit.....	8.4
Engine Oil Circuit Description.....	8.5
Heat Exchanger.....	8.5
Engine Oil.....	8.6
Specification.....	8.6
Triumph Engine Oil.....	8.6
Oil Level Inspection.....	8.6
Oil and Oil Filter Change.....	8.7
Disposal of Used Engine Oil.....	8.8
Oil Pump.....	8.8
Removal.....	8.8
Inspection.....	8.11
Assembly.....	8.12
Installation.....	8.13
Low Oil Pressure Warning Light Switch.....	8.14
Removal.....	8.14
Installation.....	8.14
Sump.....	8.15
Removal.....	8.15
Installation.....	8.16
Heat Exchanger.....	8.17
Removal.....	8.17
Inspection.....	8.17
Installation.....	8.18

# Lubrication

---

## Exploded View - Sump

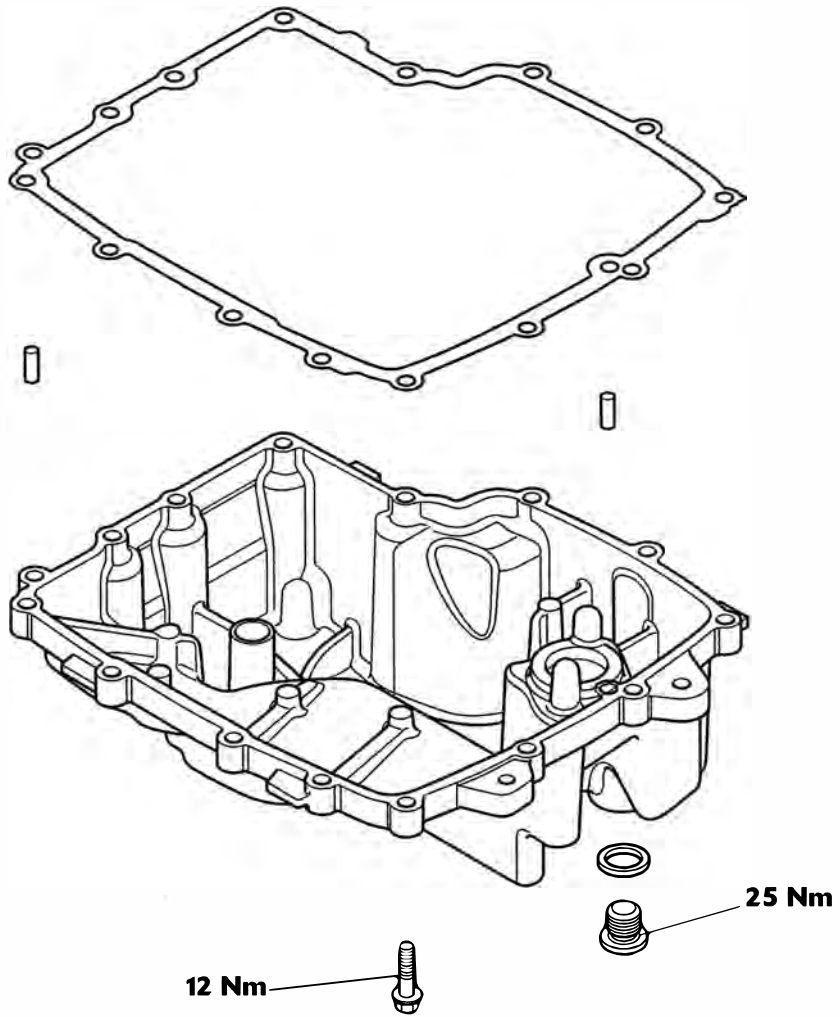

Exploded View - Oil Pump/Water Pump, Gears and Heat Exchanger

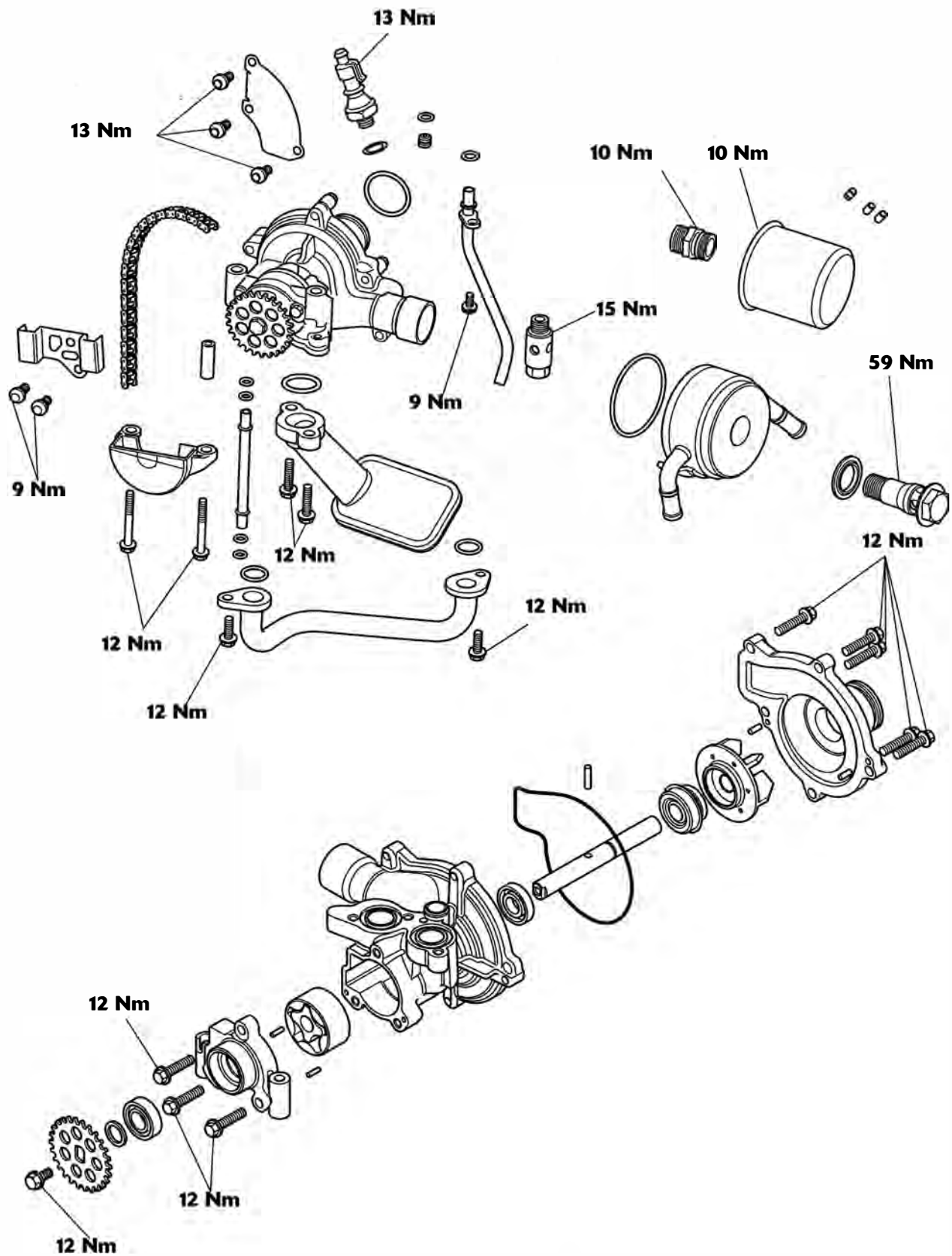

# Lubrication

## Engine Oil Circuit

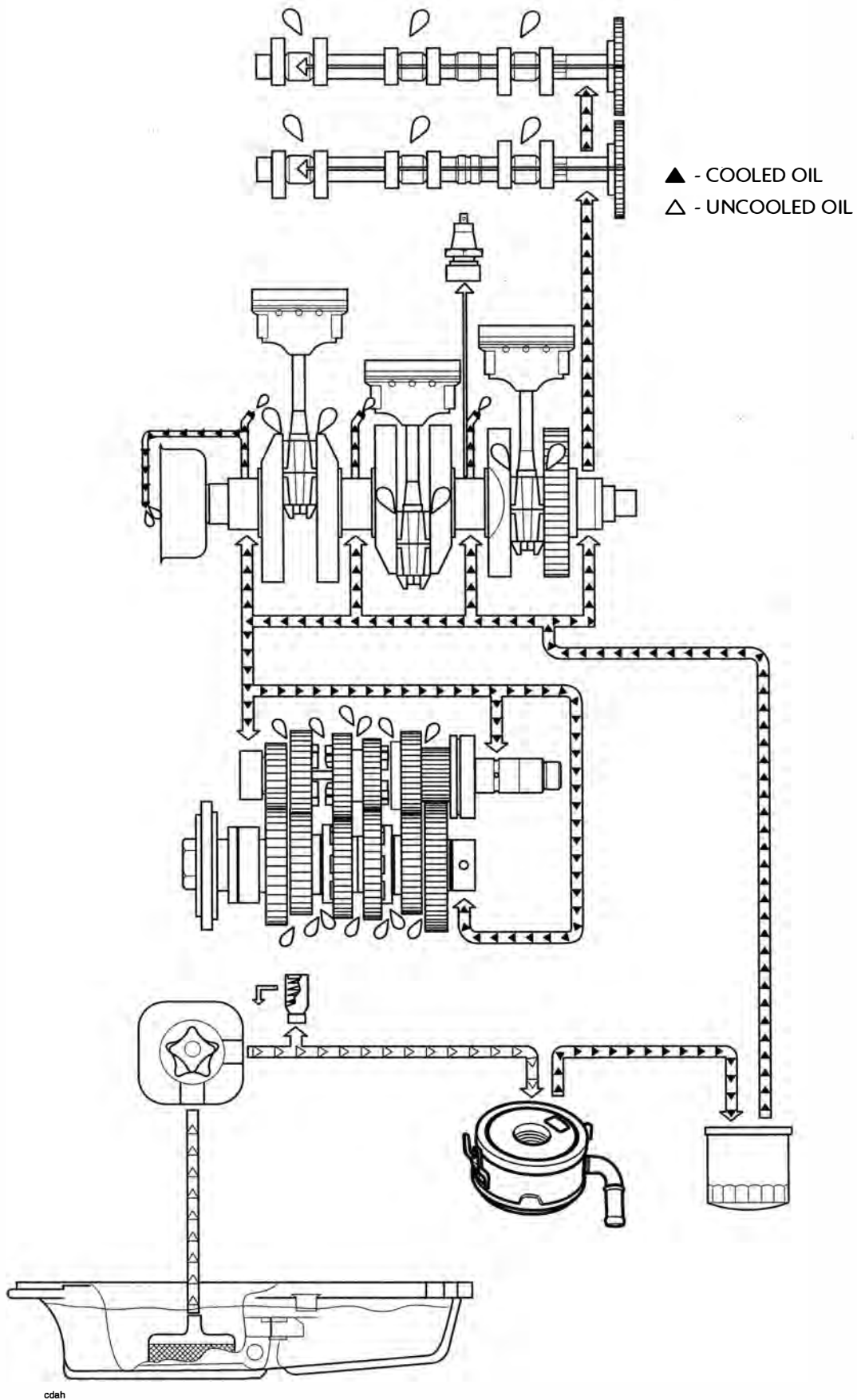

## Engine Oil Circuit Description

Oil is collected from the sump and is drawn through a mesh strainer into the oil pump rotor. The oil pump is fitted with a single pumping rotor which supplies pressurised oil to the lubrication circuit via the oil pressure relief valve. The relief valve is set to open at 5.1 bar (75 lb/in<sup>2</sup>) and when open, returns high pressure oil direct to the sump.

Pressurised oil is delivered to the oil to water heat exchanger (mounted on the front of the engine), where it is cooled.

The cooled oil is then delivered to the outside rim of the oil filter, where it is filtered by passing through the filter membrane. Filtered oil is then fed into the lower crankcase gallery. From here it is distributed around the engine:

- Oil is delivered to the crankshaft main bearings and, via drillings in the crankshaft, to the big end bearings.
- Spray jets located in the upper crankcase, behind the main bearing shells, lubricate the pistons and connecting rod small ends. These jets are fed oil from the crankshaft oil feed. A low oil pressure warning light switch is also located in the upper crankcase gallery.
- Some oil is sent directly to the cylinder head via an internal gallery. Oil that arrives at the cylinder head is fed to both cams via a gallery in the cylinder head casting that delivers oil directly to the sprocket end of the camshafts. Oil is then fed through the hollow camshafts to the other camshaft bearings, the tappet buckets and the valves.
- Oil is fed to the gearbox via internal oil pipes and drillings that supply oil directly to the end of each shaft. Oil is circulated along the gearbox shafts to exit holes that feed directly to the bearings, gears and selectors.
- **Oil is fed to the alternator to aid cooling of the alternator components. The oil is taken from the crankshaft oil feed and directed to the alternator via a spray bar, located above the alternator rotor, in the alternator cover.**

## Heat Exchanger

The heat exchanger is used to transfer heat from the engine oil into the coolant. Oil is delivered to the heat exchanger via a hollow centre bolt, after which it flows around the end tank and into the heat exchanger core, where it is circulated. Coolant is pumped around the outside of the heat exchanger core to cool the oil. The cooled oil then exits the heat exchanger and flows to the oil filter. An additional benefit of the heat exchanger is that, as the engine coolant reaches its operating temperature more quickly than the engine oil, the oil is heated by the engine coolant at lower engine temperatures; this allows the engine oil to reach its optimum operating temperature more quickly, thereby helping to improve engine oil life, reduce exhaust emissions and reduce engine wear.

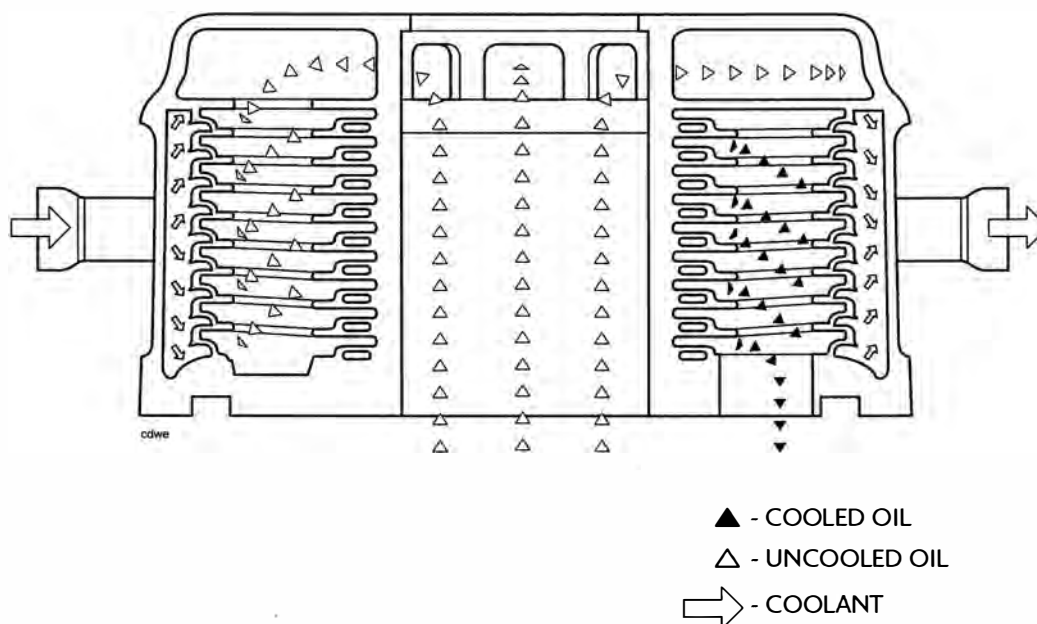

Heat Exchanger Circuit

# Lubrication

## Engine Oil

### Specification

Use semi or fully synthetic 10W/40 or 15W/50 motorcycle engine oil which meets specification API SH (or higher) and JASO MA, such as Castrol Power 1 Racing 4T, sold as Castrol Power RS Racing 4T in some countries.

### ! Caution

Triumph high performance fuel injected engines are designed to use semi or fully synthetic motorcycle engine oil which meets specification API SH (or higher) AND JASO MA.

Do not add any chemical additives to the engine oil. The engine oil also lubricates the clutch and any additives could cause the clutch to slip.

Do not use mineral, vegetable, non-detergent oil, castor based oils or any oil not conforming to the required specification. The use of these oils may cause instant, severe engine damage.

Ensure no foreign matter enters the crankcase during an oil change or top-up.

### Triumph Engine Oil

Your Triumph Motorcycle is a quality engineered product which has been carefully built and tested to exacting standards. Triumph Motorcycles are keen to ensure that you enjoy optimum performance from your machine and with this objective in mind have tested many of the engine lubricants currently available to the limits of their performance.

## Oil Level Inspection

In order for the engine, transmission, and clutch to function correctly, maintain the engine oil at the correct level, and change the oil and oil filter in accordance with scheduled maintenance requirements.

### ! Warning

Never start the engine or run the engine in a confined area. Exhaust fumes are poisonous and can cause loss of consciousness and death within a short period of time. Always operate your motorcycle in the open-air or in an area with adequate ventilation.

### ! Warning

Motorcycle operation with insufficient, deteriorated, or contaminated engine oil will cause accelerated engine wear and may result in engine or transmission seizure. Seizure of the engine or transmission may lead to loss of motorcycle control and an accident.

### ! Caution

Running the engine with insufficient oil will cause engine damage. If the low oil pressure indicator remains on, stop the engine immediately and investigate the cause.

1. Start the engine and run at idle for approximately five minutes.
2. Stop the engine, then wait for at least three minutes to allow the oil to settle.
3. Note the oil level visible in the sight glass.

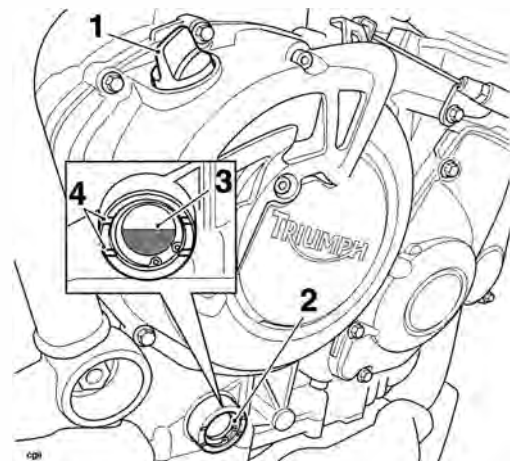

1. Filler
2. Sight glass
3. Oil level (correct level shown)
4. Crankcase oil level lines

- When correct, oil should be visible in the sight-glass at a point mid-way between the two horizontal lines marked on the crankcase.

**Note:**

- An accurate indication of the level of oil in the engine is only shown when the engine is at normal operating temperature and the motorcycle is upright (not on the side stand).**
- If it is necessary to top up the oil level, remove the filler plug and add oil, a little at a time, until the level registered in the sight glass is correct.
  - Once the correct level is reached, fit and tighten the filler plug.

## Oil and Oil Filter Change



### Warning

Prolonged or repeated contact with engine oil can lead to skin dryness, irritation and dermatitis. In addition, used engine oil contains potentially harmful contamination which can cause cancer. Wear suitable clothing and avoid skin contact.

The engine oil and filter must be replaced in accordance with scheduled maintenance requirements.

- Warm up the engine thoroughly, and then stop the engine.
- Place an oil pan beneath the engine.



### Warning

The oil may be hot to the touch. Contact with hot oil may cause the skin to be scalded or burned.

- Remove the oil drain plug.

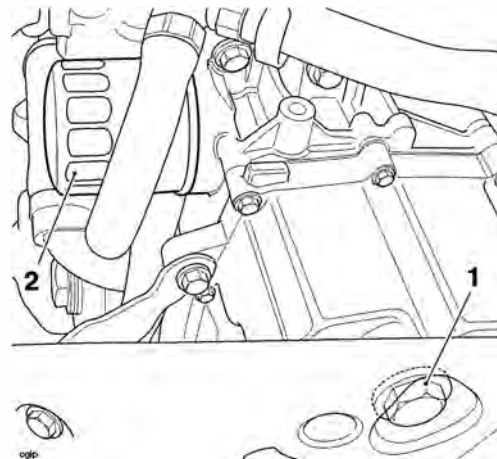

**1. Oil drain plug**

**2. Oil filter**

- With the motorcycle on level ground, and on the sidestand, allow the oil to completely drain.
- Unscrew and remove the oil filter using Triumph service tool T3880313.
- Dispose of the old filter in an environmentally friendly way.
- Apply a smear of clean engine oil to the sealing ring of the new oil filter.
- Fit the oil filter and tighten to **10 Nm** using Triumph service tool T3880313.
- After the oil has completely drained out, fit a new sealing washer to the drain plug. Fit and tighten the plug to **25 Nm**.

## Lubrication

10. Fill the engine with new oil of the type and grade listed previously and in the specification section.
11. Start the engine and allow it to idle for a minimum of 30 seconds.

### **Caution**

Raising the engine speed above idle before the oil reaches all parts of the engine can cause engine damage or seizure. Only raise engine speed after running the engine for 30 seconds to allow the oil to circulate fully.

12. Ensure that the oil pressure warning light extinguishes shortly after starting.

### **Caution**

If the engine oil pressure is too low, the low oil pressure warning light will illuminate. If this light stays on when the engine is running, stop the engine immediately and investigate the cause. Running the engine with low oil pressure will cause engine damage.

13. Stop the engine and check the oil level. Adjust if necessary.

### Disposal of Used Engine Oil

To protect the environment, do not pour oil on the ground, down sewers or drains, or into water courses. Dispose of used oil sensibly. If in doubt contact your local authority.

## Oil Pump

### **Warning**

Prolonged or repeated contact with engine oil can lead to skin dryness, irritation and dermatitis. Furthermore, used engine oil contains potentially harmful contaminants which can cause cancer.

When handling used engine oil, always wear protective clothing and avoid any skin contact with the oil.

### **Caution**

Do not pour engine oil on the ground, down sewers or drains, or into water courses. To prevent pollution of water courses etc., dispose of used oil sensibly. If in doubt contact your local authority.

### Removal

#### Note:

- **The oil pump and water pump are supplied as an assembly and cannot be separated. This procedure covers the removal of the oil and water pump assembly.**

1. Remove the rider's seat (see page 16-13).
2. Disconnect the battery, negative (black) lead first.
3. Drain the coolant (see page 11-5).
4. Drain the engine oil (see page 8-7).

### **Warning**

The oil may be hot to the touch. Contact with hot oil may cause the skin to be scalded or burned.



## Warning

Prolonged or repeated contact with engine oil can lead to skin dryness, irritation and dermatitis. In addition used engine oil contains potentially harmful contaminants which can cause cancer. Wear suitable clothing and avoid skin contact.

5. Remove the sump (see page 8-15).
6. Remove the clutch (see page 4-6).
7. Release and discard the two fixings and remove the oil transfer pipe. Remove and discard the two O-ring seals.

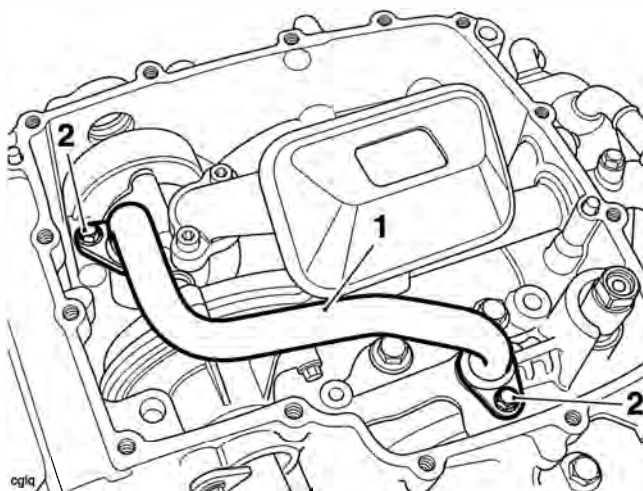

1. Oil transfer pipe
2. Fixings

8. Release and discard the two fixings and remove the oil pick-up. Remove and discard the O-ring seal.

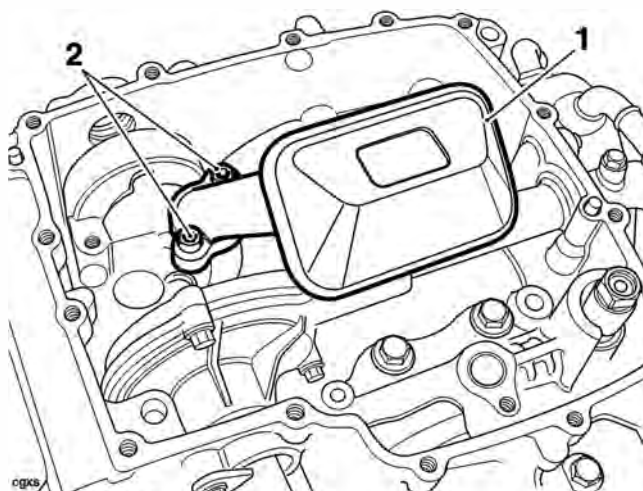

1. Oil pick-up
2. Fixings

9. Remove and discard the bolt securing the coolant inlet elbow to the crankcase and withdraw the elbow. Remove and discard the O-ring from the elbow.

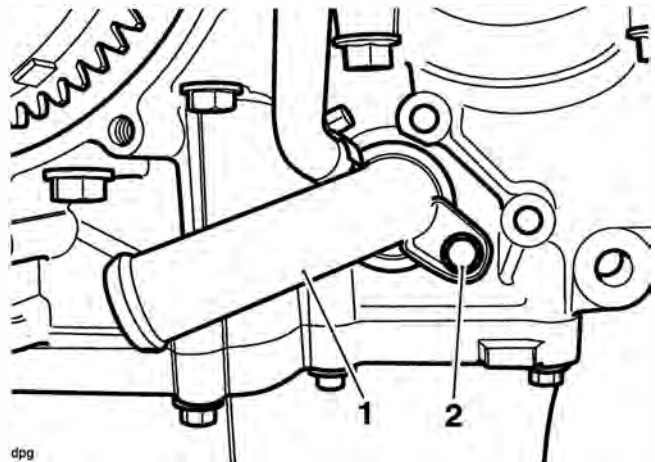

1. Coolant inlet elbow
2. Fixing

10. Remove and discard the bolt securing the coolant outlet pipe to the crankcase and withdraw the pipe. Remove and discard the three O-rings from the pipe.

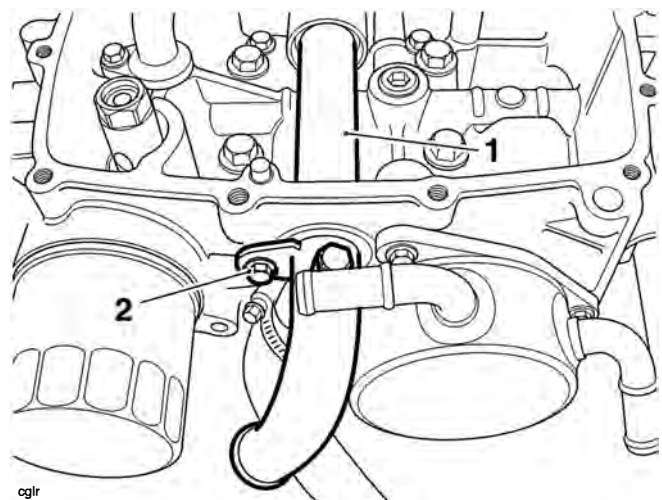

1. Coolant outlet pipe
2. Fixing

# Lubrication

11. Release the fixings securing the drive chain guide to the crankcase and remove the guide.

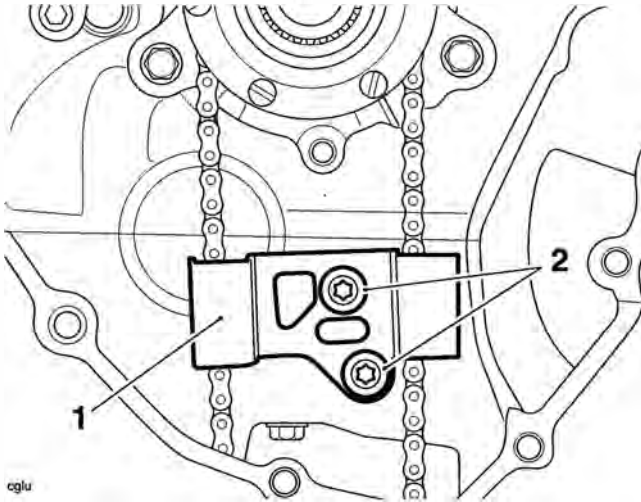

- 1. Oil pump drive chain guide**  
**2. Fixings**

12. Slide the oil pump drive sprocket gently backwards and forwards to dislodge the inner needle roller bearing.

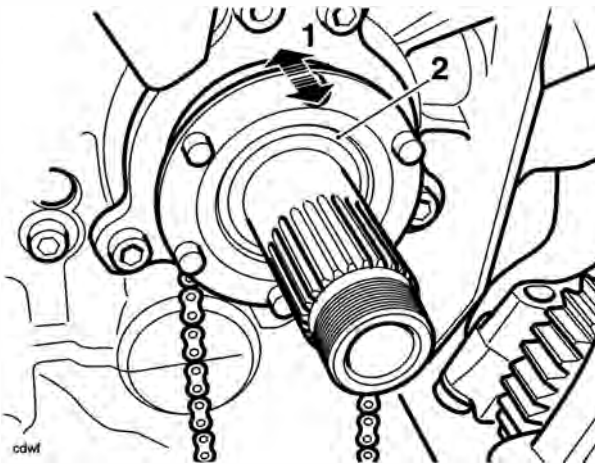

- 1. Oil pump drive sprocket**  
**2. Needle roller bearing**

13. Carefully remove the bearing while supporting the oil pump drive sprocket.

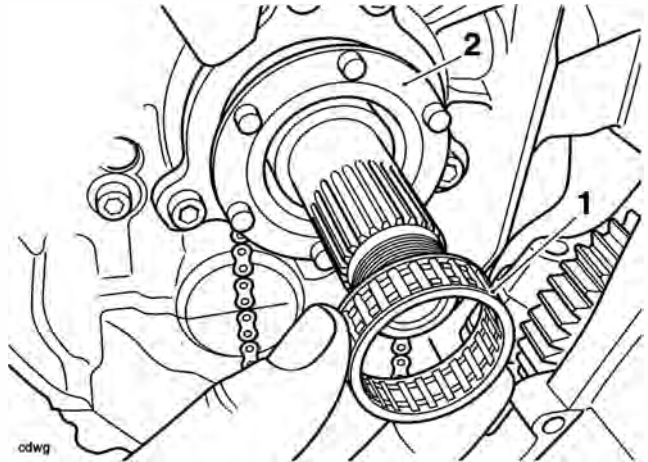

- 1. Needle roller bearing**  
**2. Oil pump drive sprocket**

14. Release the fixings securing the drive chain cover to the oil pump. Remove the drive chain cover.

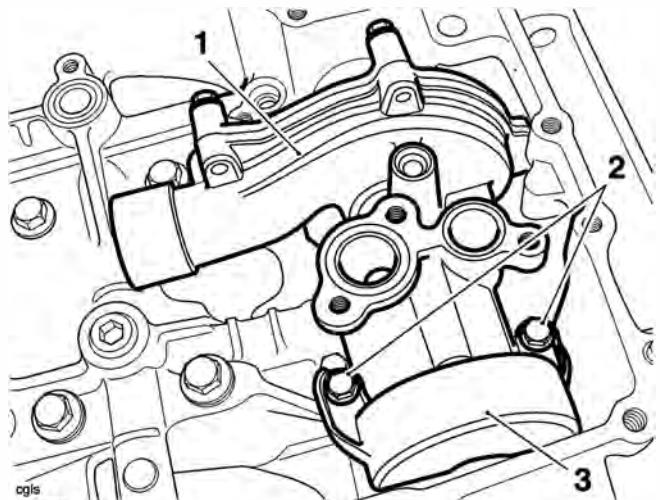

- 1. Oil pump**  
**2. Fixings**  
**3. Drive chain cover**

- Using a suitable tool, slide the dowel upwards to release the oil pump from the crankcase. It is not necessary to remove the dowel completely from the oil pump.

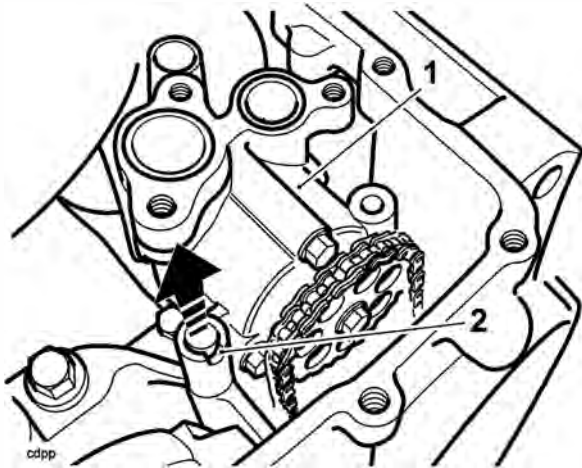

- Oil pump
- Dowel

- Detach the drive chain from the oil pump.

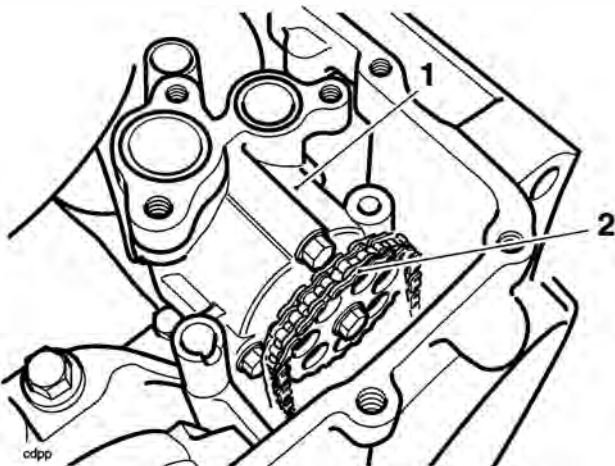

- Oil pump
- Drive chain

- Carefully withdraw the oil pump from the crankcase.
- Remove and discard the O-ring from the inlet sleeve on the water pump body.

## Inspection

- Release the fixing and remove the drive sprocket and spacer washer.

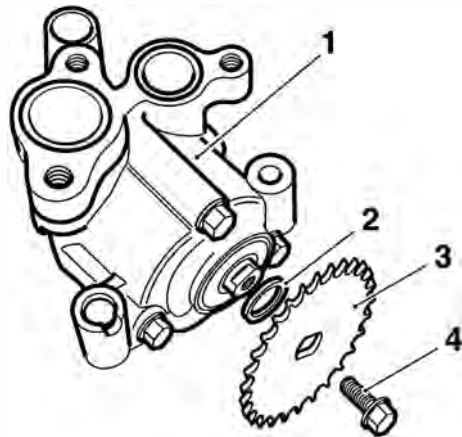

- Oil pump
- Spacer washer
- Drive sprocket
- Fixing

- Release the three fixings and withdraw the oil pump body.

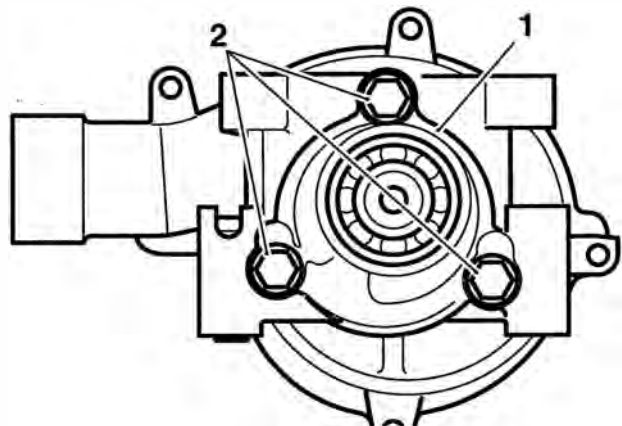

- Oil pump body
- Fixings



## Caution

If any part of the oil pump is found to be outside the service limit, the complete pump must be replaced. Severe engine damage may result from the continued use of a faulty oil pump.

# Lubrication

3. Measure the rotor tip clearance using feeler gauges.

## Rotor Tip Clearance

Standard:	0.15 mm
Service limit:	0.20 mm

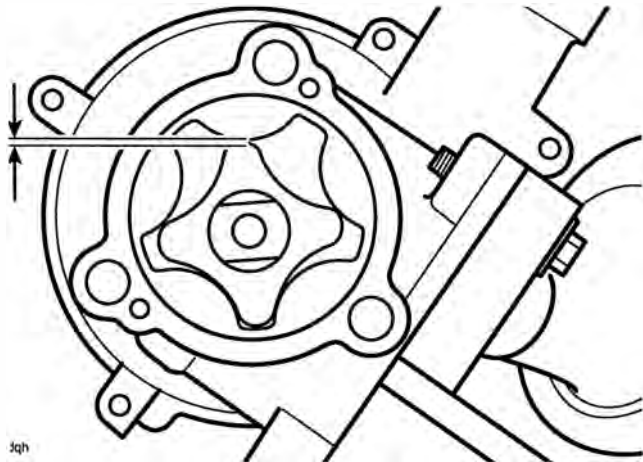

**Rotor Tip Clearance**

4. Measure the pump body clearance using feeler gauges.

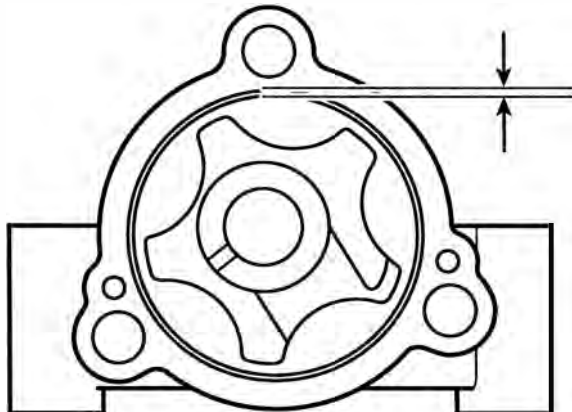

**Pump Body Clearance**

## Pump Body Clearance

Standard:	0.15 - 0.22 mm
Service limit:	0.35 mm

5. Measure the pump end clearance.

## Pump End Clearance

Standard:	0.04 - 0.09 mm
Service limit:	0.17 mm

## Assembly

1. If all clearances are within service limits, liberally apply clean engine oil to all internal components and refit the oil pump body to the oil pump rotor. Refit the fixings and tighten to **12 Nm**.
2. If any clearance measured is outside the service limits, renew the complete pump.
3. Inspect the sprockets and chain for wear and/or damage. Replace the sprockets and chain if wear and/or damage is found.
4. Check the water pump shaft and shaft bearings for side and end float. Renew if necessary.
5. Check for corrosion and scale build-up around the impeller and in the pump body. Renew if necessary.
6. Check the oil pump location dowel for damage. Renew if necessary.
7. Refit the spacer washer and drive sprocket. Apply ThreeBond 1374 to the fixing and tighten to **12 Nm**.

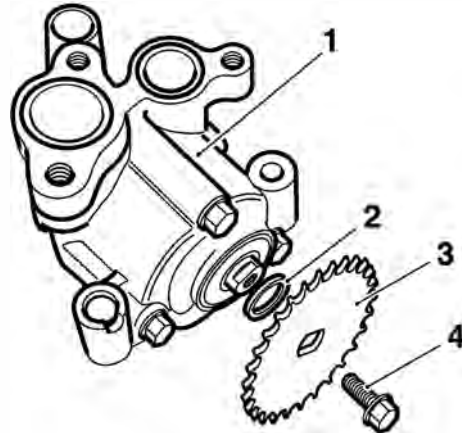

1. Oil pump
2. Spacer washer
3. Drive sprocket
4. Fixing

## Installation

### ⚠ Caution

Before fitting the oil pump to the crankcase ensure the pump internal surfaces have been 'wetted' with clean engine oil. The pump may fail to pick-up oil from the sump if the surfaces have not been 'wetted'. This will cause the engine to run without engine oil pressure and will lead to severe engine damage.

1. Install a new O-ring to the inlet sleeve on the water pump body.
2. Fill the oil pump with new engine oil, turning the pump rotor as the oil is poured in to ensure all surfaces are coated with oil.
3. Position the oil pump to the crankcase and insert the water pump inlet sleeve into the opening in the crankcase.
4. Fit the oil pump to the crankcase, ensuring the oil pump dowel correctly locates into the bolt hole in the crankcase.

### ⚠ Caution

Do not use excessive force to insert the dowel into the crankcase. Severe dowel or crankcase damage may result from the use of excessive force.

5. Using a suitable pin punch, gently tap the dowel downwards into the crankcase until it seats.
6. Feed the drive chain over the transmission input shaft and fit to the sprocket.
7. Fit the drive chain to the sprocket on the oil pump.
8. Support the oil pump drive sprocket and carefully refit the needle roller bearing.

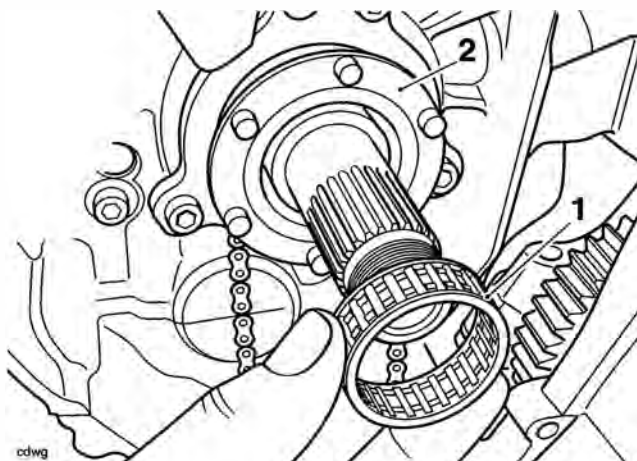

1. Needle roller bearing
2. Oil pump drive sprocket

9. Refit the oil pump drive chain cover to the oil pump and fit new bolts. Tighten the bolts to **12 Nm**.

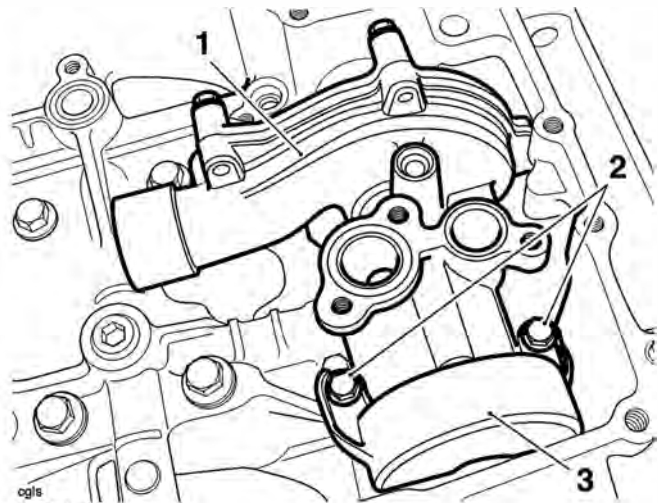

1. Oil pump
2. Fixings
3. Drive chain cover

10. Refit the oil pump drive chain guide. Install new fixings and tighten to **9 Nm**.
11. Install a new O-ring to the coolant inlet elbow and position the elbow to the water pump inlet. Fit a new bolt and tighten to **12 Nm**.

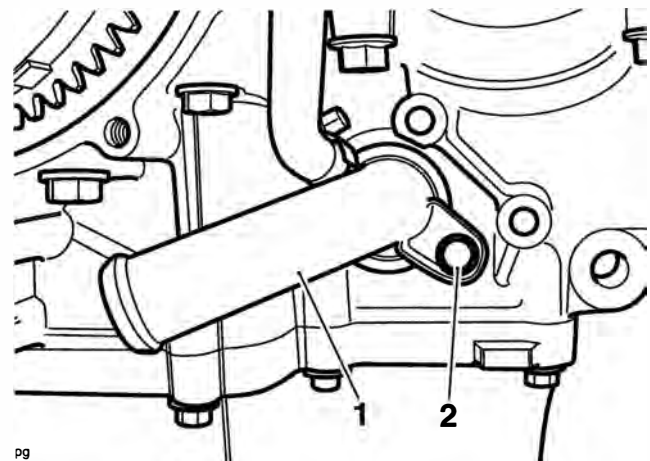

1. Coolant inlet elbow
2. Fixing

# Lubrication

12. Install three new O-rings to the coolant outlet pipe and position the pipe through the crankcase, locating it to the water pump outlet. Install a new fixing and tighten to **12 Nm**.

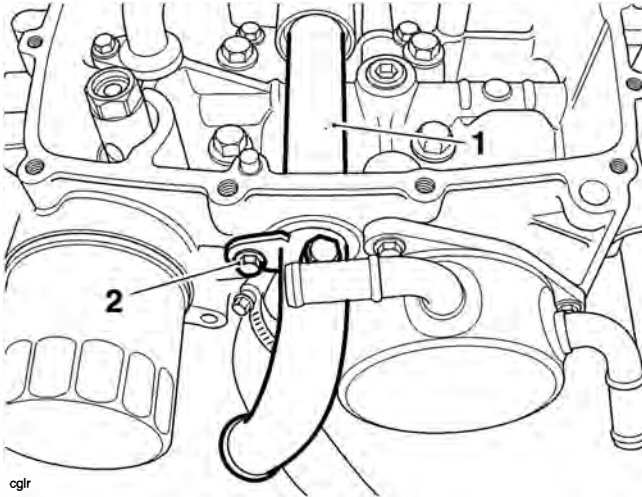

cglr

1. Coolant outlet pipe
2. Fixing

13. Install a new O-ring to the oil pick-up and refit the oil pick-up. Fit new bolts and tighten to **12 Nm**.
14. Install two new O-rings to the oil transfer pipe and refit the oil transfer pipe. Fit new bolts and tighten to **12 Nm**.
15. Refit the clutch (see page 4-10).
16. Refit the sump, ensuring the water pump drain tube is correctly installed (see page 8-16).
17. Reconnect the battery, positive (red lead) first.
18. Refit the rider's seat (see page 16-13).
19. Refill the engine with oil (see page 8-7).
20. Refill the cooling system (see page 11-5).

## Low Oil Pressure Warning Light Switch

The low oil pressure warning light switch is located in the upper crankcase, behind the cylinder head.

### Removal

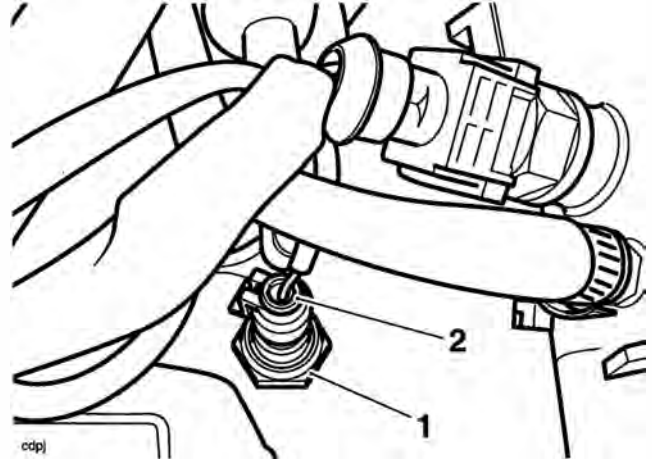

1. Low oil pressure warning light switch
2. Electrical connection

1. Remove the rider's seat (see page 16-13).
2. Disconnect the battery, negative (black) lead first.
3. Disconnect the electrical connection to the switch.
4. Remove the switch and collect the copper washer.

### Installation

1. Incorporating a new copper washer, fit the switch and tighten to **13 Nm**.
2. Refit the electrical connection.
3. Reconnect the battery, positive (red) lead first.
4. Refit the rider's seat (see page 16-13).

## Sump

### Removal

1. Remove the rider's seat (see page 16-13).
2. Disconnect the battery, negative (black) lead first.
3. Drain the engine oil (see page 8-7).

### Warning

The oil may be hot to the touch. Contact with hot oil may cause the skin to be scalded or burned.

### Warning

Prolonged or repeated contact with engine oil can lead to skin dryness, irritation and dermatitis. In addition used engine oil contains potentially harmful contaminants which can cause cancer. Wear suitable clothing and avoid skin contact.

4. Remove the sump guard (see page 16-24).
5. Remove the three fixings and remove the sump guard bracket.

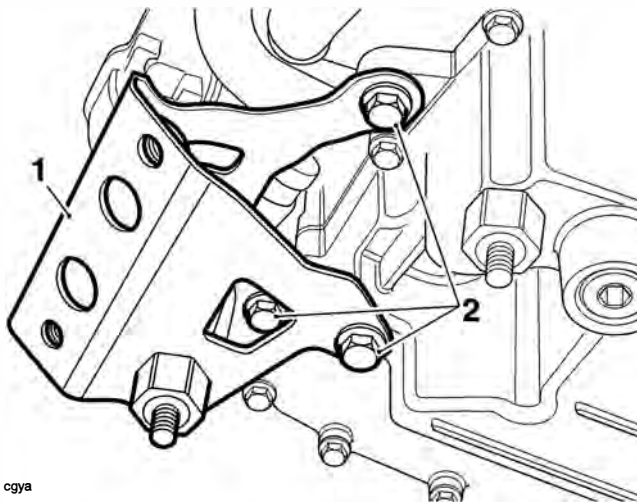

cgya

1. Sump guard bracket
2. Fixings

6. Remove the exhaust system (see page 10-118).

### Warning

The exhaust system will be hot if the engine has recently been running. Always allow sufficient time for the exhaust to cool before working on or near the exhaust system.

Contact with a hot exhaust could result in burn injuries.

7. Release the fixings securing the sump to the lower crankcase.

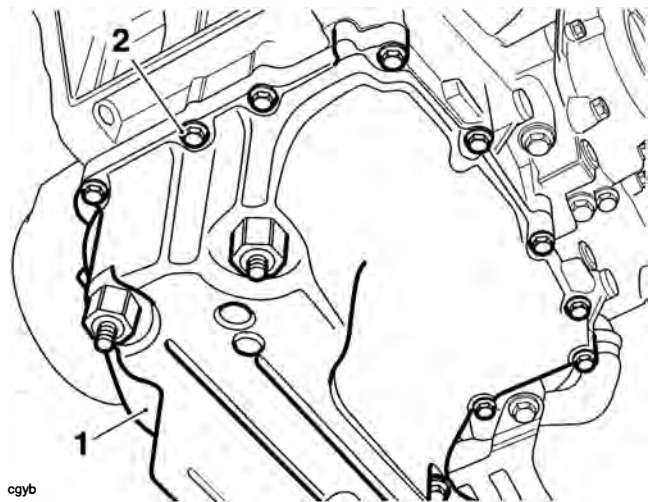

cgyb

1. Sump
2. Fixings

8. Detach the sump and collect the water pump drain tube. Remove and discard the four drain tube O-rings.

#### Note:

- The water pump drain tube may remain attached to the water pump or become detached with the sump.

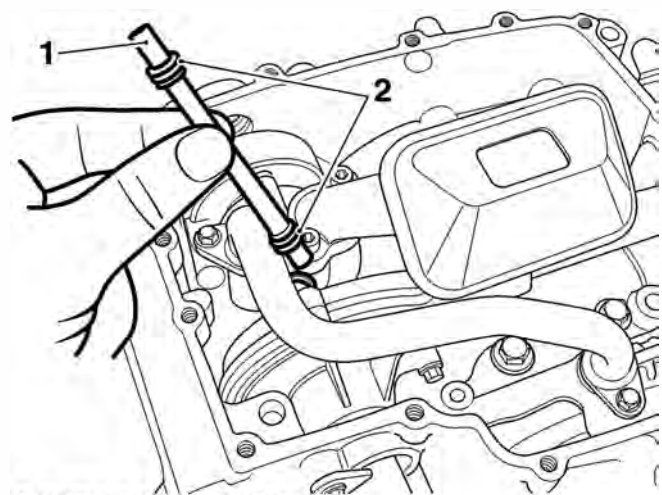

1. Water pump drain tube
2. O-rings

# Lubrication

## Installation

1. Incorporating new O-rings (two each end of the tube), position the water pump drain tube to the oil pump.

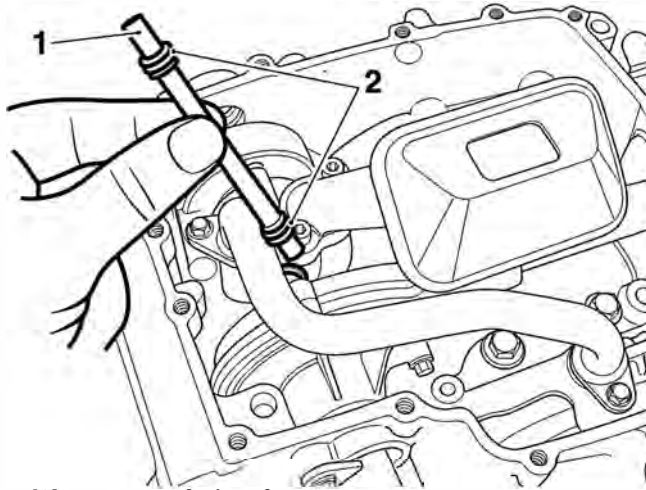

1. Water pump drain tube
2. O-rings

2. Incorporating a new sump gasket/baffle, position the sump to the lower crankcase.
3. Tighten the sump fixings to **12 Nm**.

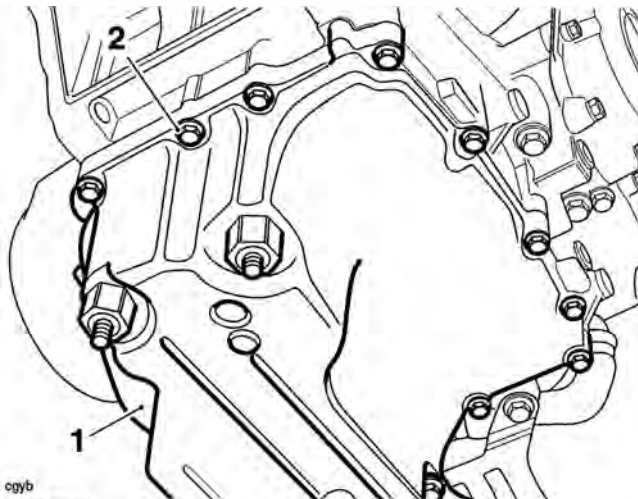

ogyb

1. Sump
2. Fixings

4. Refit the exhaust system (see page 10-95).

5. Refit the sump guard bracket and secure with the three fixings. Tighten to **15 Nm**.

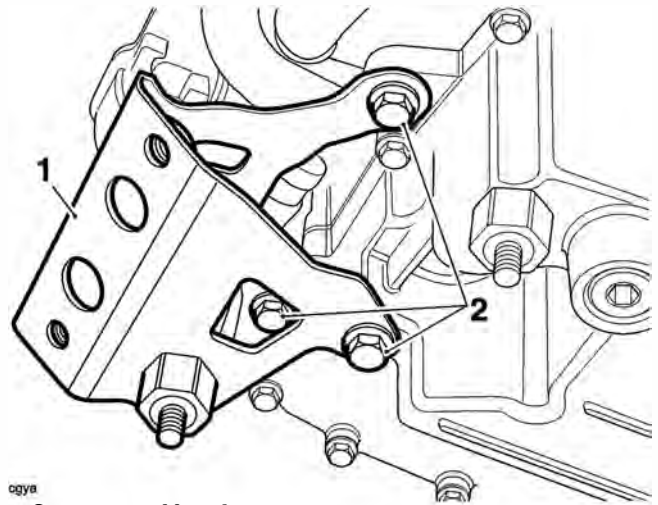

ogyb

1. Sump guard bracket
2. Fixings

6. Refit the sump guard (see page 16-21).

### Note:

- **Use new exhaust gaskets at the downpipe connections with the cylinder head.**
7. Fill the engine with the correct grade of engine oil (see page 8-6).
  8. Reconnect the battery, positive (red) lead first.
  9. Start the engine and ensure that the low oil pressure warning light goes out shortly after starting.
  10. Stop the engine and check the engine oil level. Adjust if necessary (see page 8-6).
  11. Refit the rider's seat (see page 16-13).



## Heat Exchanger

### Removal

#### Note:

- **Prior to disassembly of the coolant hoses, note the orientation and position of the hose clips to help ensure that they are returned to the same positions and orientation on assembly.**

1. Position the motorcycle on level ground on the sidestand.
2. Remove the rider's seat (see page 16-13).
3. Disconnect the battery, negative (black) lead first.
4. Drain the coolant (see page 11-5).
5. Drain the engine oil (see page 8-7).



### Warning

The oil may be hot to the touch. Contact with hot engine oil may cause skin to be scalded or burnt.



### Warning

Prolonged or repeated contact with engine oil can lead to skin dryness, irritation and dermatitis. In addition used engine oil contains potentially harmful contaminants which can cause cancer. Wear suitable clothing and avoid skin contact.

6. Disconnect the coolant hoses from the heat exchanger.

7. Remove the centre bolt from the heat exchanger and withdraw it from the crankcase. Remove and discard the heat exchanger O-ring and the centre bolt sealing washer.

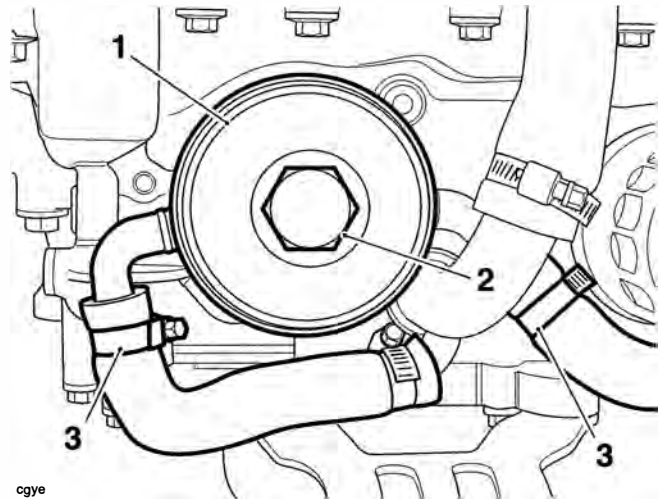

cgye

1. Heat exchanger
2. Centre bolt
3. Coolant hose clips

### Inspection

1. Check the heat exchanger body for corrosion and/or damage.

# Lubrication

## Installation

1. Fit a new O-ring to the heat exchanger, and a new sealing washer to the centre bolt.

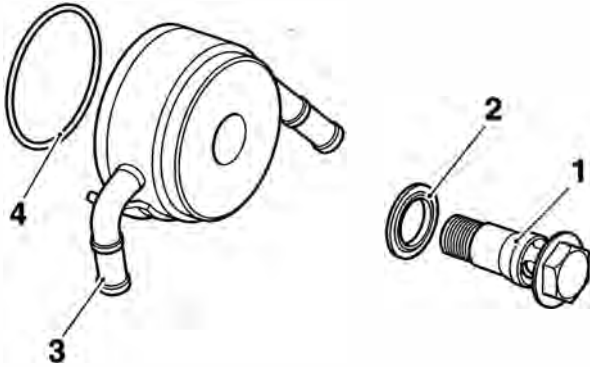

1. Centre bolt
2. Sealing washer
3. Heat exchanger
4. O-ring

### Note:

- To ensure correct positioning, ensure that the tab on the heat exchanger locates in the boss provided in the crankcase.



## Caution

Do not rely on the tab to hold the heat exchanger in position while tightening the centre bolt. The tab will bend and will not prevent the heat exchanger from turning. Instead, firmly hold the heat exchanger in position by hand.

2. Fit the heat exchanger to the crankcase and tighten the centre bolt to **59 Nm**.
3. Fit the coolant hoses to the heat exchanger and tighten the coolant hose clips.

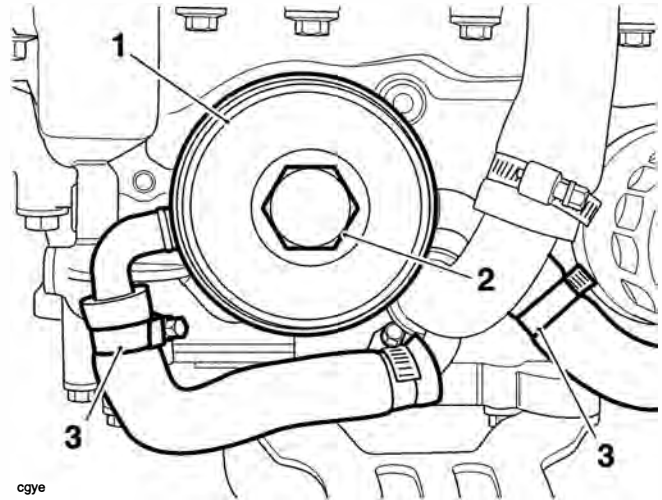

cgys

1. Heat exchanger
2. Centre bolt
3. Coolant hose clips

4. Refill the cooling system (see page 11-5).
5. Refill the engine with oil (see page 8-7).
6. Reconnect the battery, positive (red) lead first.
7. Start the engine and check for oil leaks. Once a leak check has been made, stop the engine and allow to stand for 3 minutes.
8. Adjust the engine oil level (see page 8-6).
9. Refit the rider's seat (see page 16-13).

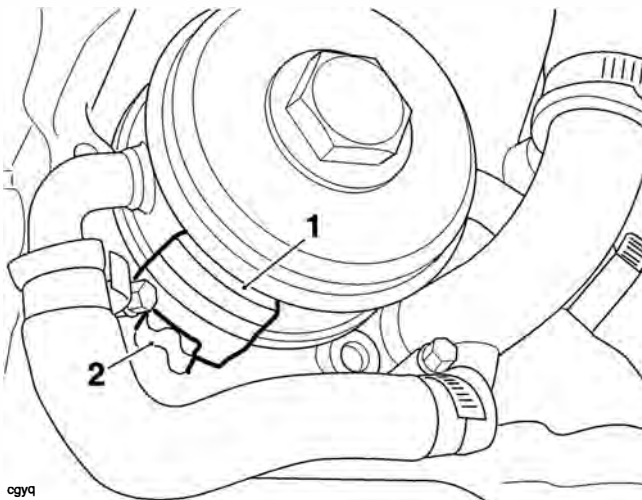

cgys

1. Heat exchanger tab
2. Crankcase boss

# 9 Engine Removal/Refit

## Table of Contents

Exploded View - Frame Fixings.....	9.2
Engine Removal/Refit.....	9.3
Removal.....	9.3
Installation.....	9.5

# Engine Removal/Refit

## Exploded View - Frame Fixings

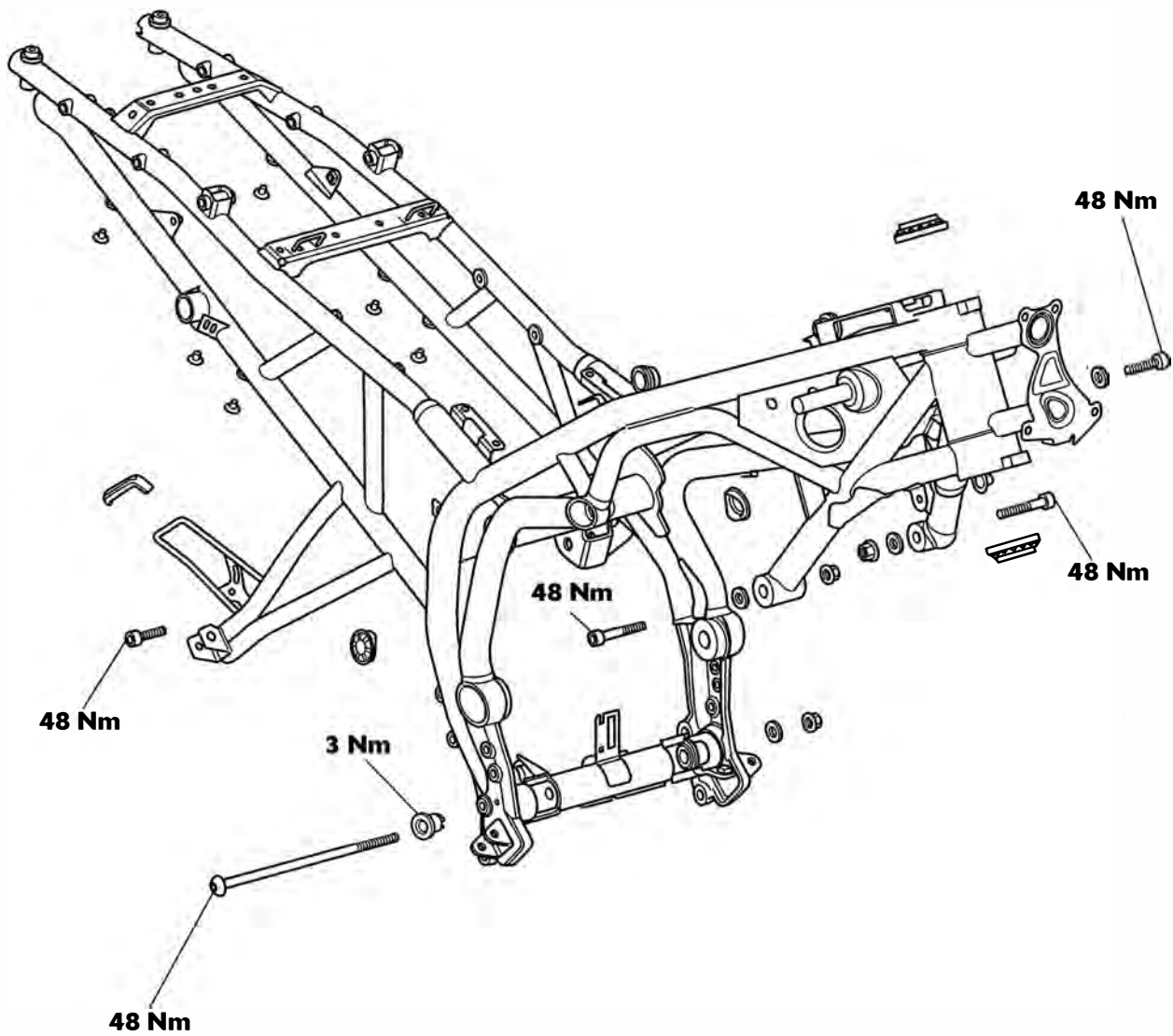

## Engine Removal/Refit

### Removal

#### Warning

Before starting work, ensure the motorcycle is stabilised and adequately supported. This will help prevent it from falling and causing injury to the operator or damage to the motorcycle.

1. Raise and support the motorcycle.
2. Remove the rider's seat (see page 16-13).
3. Disconnect the battery, negative (black) lead first and remove the battery (see page 17-8).
4. Remove the fuel tank (see page 10-91).
5. Remove the airbox (see page 10-98).
6. Remove the throttle bodies (see page 10-107).
7. Drain the engine oil (see page 8-7).
8. Drain the coolant (see page 11-5).
9. Remove the radiator (see page 11-11).

#### Note:

- **Secure the coolant hoses to prevent damage as the engine is removed.**

10. Temporarily remove the sump guard (see page 16-24).
11. Remove the exhaust system completely (see page 10-118).
12. Refit the sump guard (see page 16-21).
13. Support the engine on proprietary lifting jacks, at the front and rear. Position the jacks under the sump guard, directly under the four fixings.
14. Secure the engine to the jacks, using suitable straps, to prevent it from moving or falling as the frame is removed.
15. Disconnect the gearchange linkage at the gearbox shaft.
16. Remove the sprocket cover.

#### Caution

To prevent chain damage, do not allow the chain to come into contact with dirt, road grit etc.

17. Set the drive chain adjustment to allow maximum free play in the chain (see page 12-8).
18. Remove the swinging arm (see page 12-13).
19. Detach the drive chain from the front sprocket and remove it.
20. Noting their routing, disconnect the electrical connections from the main harness to the engine.
21. Remove the bolt and detach the engine earth cables from the rear of the crankcase. Note the order of the earth terminals on the bolt before removal.
22. Remove the bolt and detach the engine starter cable from the starter motor.
23. Slacken the cable locknut and release the adjuster at the clutch cover end to give maximum play in the cable.
24. Release the clutch cable from the actuating arm by pushing the inner cable nipple through the arm and sliding the cable out of the slot. Detach the cable from the bracket.

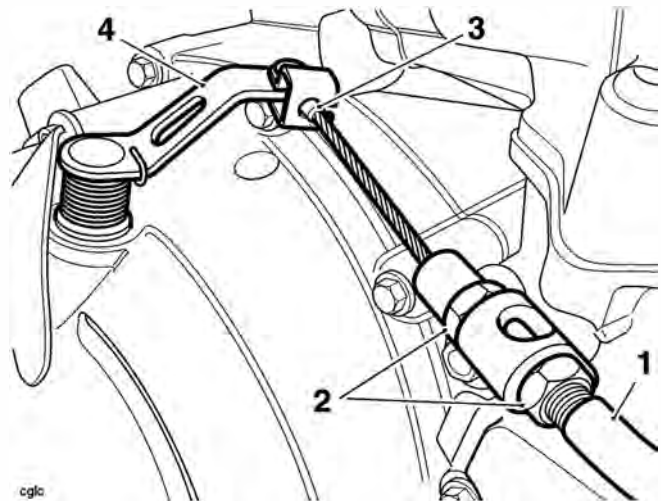

1. Clutch cable
2. Adjuster
3. Inner cable nipple
4. Actuating arm

25. Remove the front wheel (see page 15-10).
26. Ensure that the engine is still adequately and securely supported.
27. Support the frame centrally using suitable lifting equipment.

The frame is fitted with two different mounting conditions at the rear lower gearbox mounting bolt. Either of these conditions may be found on any motorcycle from the start of production.

These consist of either of the following:

# Engine Removal/Refit

- the frame is fitted with a conventional adjuster sleeve, located on the left hand side of the frame;
- the frame is fitted with a shim (available in varying thicknesses) located between the crankcase and the engine mounting boss. This arrangement is also fitted with a spacer plate, permanently fitted to the crankcase. A frame adjuster sleeve is fitted to the frame, however this is fitted from the outside of the frame (so that the adjuster slots are inside the frame). This sleeve is not used for frame adjustment; it is only for bolt location purposes.

28. Noting the mounting arrangement described above, release the nut securing the rear lower gearbox mounting bolt. Collect the hardened washer from under the nut.
29. Remove the bolt.

## Models Fitted with a Frame Adjustment Shim

1. Collect and retain the shim.

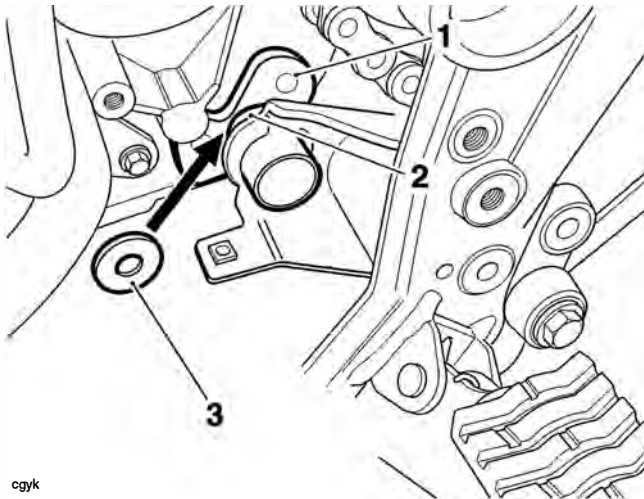

cgylk

1. Crankcase plate
2. Frame boss
3. Shim

## Models Fitted with a Frame Adjuster Sleeve

1. Using tool T3880166 loosen the frame adjuster and unscrew it fully to allow clearance between the frame and engine.

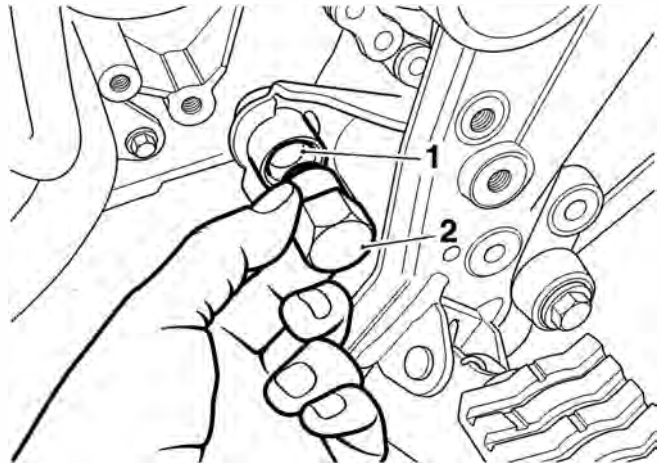

1. Rear lower frame adjuster sleeve
2. Tool T3880166

## All Models:

1. Note the position of the two spacers installed to the two cylinder head bolts, on the left hand side of the engine.
2. Remove the rear cylinder head mounting bolts. Collect the spacer from between the left hand mounting and the frame.
3. Remove the front cylinder head mounting bolts. Collect the spacer from between the left hand mounting and the frame, and the washer from under the right hand bolt head.



## Caution

Damage to painted surfaces, such as the frame, cylinder head or crankcases, could result from inadequate care during this process.

4. Carefully lower the frame at the front and raise it at the rear until the rear lower mount clears the crankcase.
5. Carefully lift the frame from the engine in an upwards direction, ensuring the front cylinder head mounts are clear of the cylinder head, and the rear mounting is clear of the crankcase.

## Installation

1. Support the engine on proprietary lifting jacks, at the front and rear. Position the jacks under the sump guard, directly under the four fixings.
2. Secure the engine to the jacks, using suitable straps, to prevent it from moving or falling as the frame is installed.
3. Carefully lower the frame over the engine, front first so the front mountings pass under the cylinder head mountings. Lower the rear of the frame until the rear cylinder head mountings align. Fit the right hand bolt, but do not tighten at this stage.
4. Fit the spacer to the left hand rear cylinder head mounting as noted during removal. Fit the left hand bolt, but do not tighten at this stage.
5. Lower the rear of the frame until the rear lower mounting aligns. Fit the bolt from the right hand side. Do not fit the nut at this stage.
6. Fit the spacer to the left hand front cylinder head mounting as noted during removal. Fit the washer under the right hand front cylinder head bolt as noted during removal.

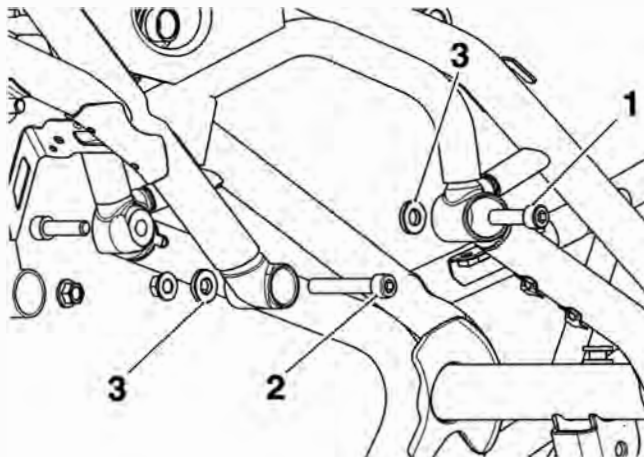

1. Left hand rear cylinder head bolt
2. Left hand front cylinder head bolt
3. Spacers

7. Fit the front cylinder head bolts from the outside. Fit new nuts but do not fully tighten at this stage.

## Models Fitted with a Frame Adjuster Sleeve

1. Partially withdraw the rear lower engine mounting bolt (fitted at step 5) to allow tool T3880166 to be installed to the frame adjuster sleeve.
2. Using tool T3880166, tighten the rear frame adjuster sleeve to **3 Nm**.

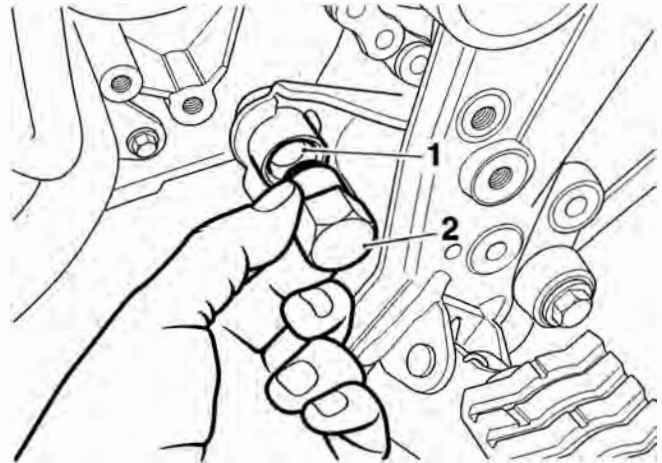

1. Frame adjuster sleeve
2. Tool T3880166

## Models Fitted with a Frame Adjustment Shim

### Note:

- The shim must be selected and installed as described below.

1. Partially withdraw the rear lower engine mounting bolt (fitted at step 5) to allow a shim to be installed between the left hand frame boss and the crankcase.
2. Without using force, install the largest possible shim between the frame boss and the crankcase plate. Do not install more than one shim.
3. Shims are available in 0.5 mm increments from 0.5 mm to 3.5 mm.

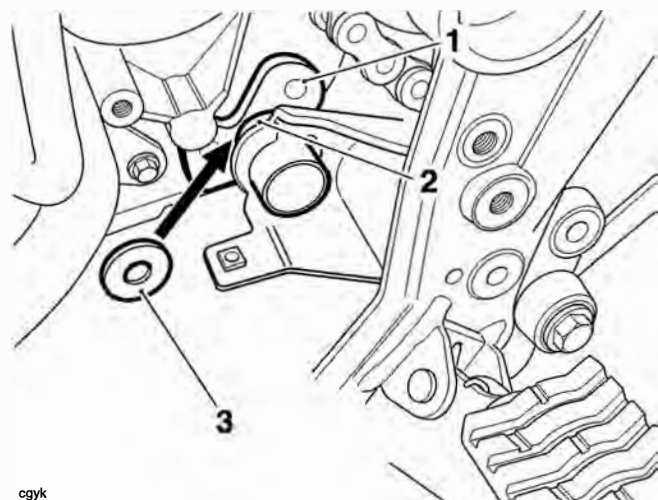

ogyk

1. Crankcase plate
2. Frame boss
3. Shim

# Engine Removal/Refit

## All models

1. Fully insert the lower rear gearbox mounting bolt, refit the hardened washer and fit a new nut. Do not fully tighten at this stage.

### **Caution**

Unless the following engine mounting bolt installation/tightening sequence is precisely followed, severe frame damage can occur.

2. Tighten the engine mounting bolts as shown below.
  - Tighten the right hand rear cylinder head (1) bolt to **48 Nm**.
  - Tighten the right hand front cylinder head (2) bolt to **48 Nm**.
  - Tighten the left hand rear cylinder head bolt (3) to **48 Nm**.
  - Tighten the left hand front cylinder head bolt (4) to **48 Nm**.
  - Tighten the rear lower rear gearbox mounting bolt (5) to **48 Nm**.

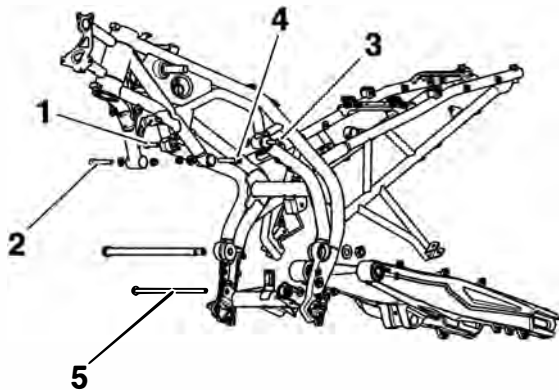

1. Right hand rear cylinder head bolt
2. Right hand front cylinder head bolt
3. Left hand rear cylinder head bolt
4. Left hand front cylinder head bolt
5. Rear lower rear gearbox mounting bolt

3. Refit the swinging arm (see page 12-15).
4. Refit the clutch cable (see page 4-5).
5. Reconnect all electrical connections to the engine.
6. Refit the gearchange linkage, aligning the slot in the gear selector arm with the dot on the gear change shaft. Refit the bolt and tighten to **9 Nm**.
7. Refit the sprocket cover and tighten the bolts to **9 Nm**.

8. Fit new exhaust seals to the cylinder head. Ensure that the face of the seal with the tab is facing the cylinder head.

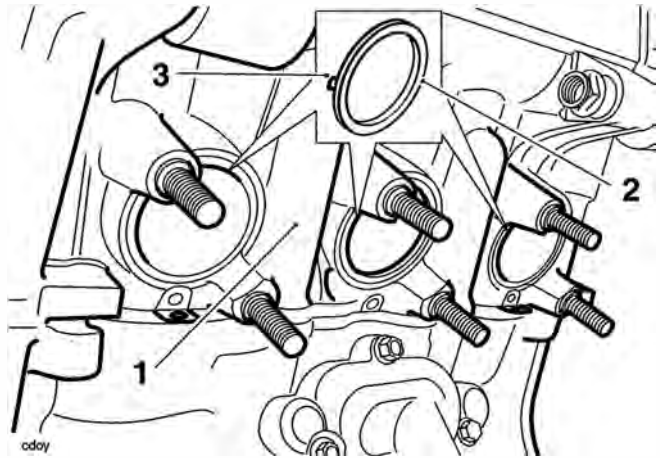

1. Cylinder head
2. Seal
3. Seal tab

9. Refit the exhaust system (see page 10-95).
10. Refit the radiator (see page 11-12).
11. Fill the engine with oil of the correct grade and viscosity (see page 8-7).
12. Refit the throttle bodies (see page 10-101).

### **Warning**

Operation of the motorcycle with incorrectly adjusted, incorrectly routed or damaged throttle cables could interfere with the operation of the brakes, clutch or the throttle itself. Any of these conditions could result in loss of motorcycle control and an accident.

### **Warning**

Move the handlebars to left and right full lock while checking that cables and harnesses do not bind. Cables or harness that bind will restrict the steering and may cause loss of motorcycle control and an accident.



13. Check the throttle cable adjustment (see page 10-104).
14. Refit the airbox (see page 10-101).
15. Refit the fuel tank (see page 10-92).
16. Refit the battery to the battery box and reconnect, positive (red) lead first (see page 17-8).
17. Refill the cooling system (see page 11-5).
18. Remove the motorcycle from the paddock stand and place on the side stand.
19. Refit the seats (see page 16-13).

This page intentionally left blank

# 10 Fuel System/Engine Management

## Table of Contents

Exploded View - Fuel Tank and Fuel Pump .....	10.7
Exploded View - Fuel Rail, Throttles and Injectors .....	10.8
Exploded View - Airbox .....	10.9
Exploded View - Exhaust System .....	10.10
Exploded View - Evaporative System .....	10.11
Fuel Requirements .....	10.12
Fuel Requirements - all countries except USA .....	10.12
Fuel Requirements - USA .....	10.12
Oxygenated Gasoline .....	10.12
Ethanol .....	10.12
Methanol .....	10.12
MTBE (Methyl Tertiary Butyl Ether) .....	10.12
Glossary of Terms .....	10.13
Air temperature .....	10.13
Air temperature sensor .....	10.13
ATDC .....	10.13
Barometric pressure .....	10.13
Battery voltage .....	10.13
BTDC .....	10.13
Catalyst .....	10.13
Closed throttle position .....	10.13
Coolant temperature .....	10.13
Coolant temperature sensor .....	10.13
Cooling fan status .....	10.13
DTC .....	10.13
ECM .....	10.13
Engine speed .....	10.13
Fall detection .....	10.13
Freeze frame .....	10.13
Gear position sensor .....	10.13
Idle fuel trim .....	10.13
Idle fueling .....	10.14
Idle reference speed .....	10.14
Ignition advance .....	10.14
Ignition switch position .....	10.14

# Fuel System/Engine Management

---

Ignition timing . . . . .	10.14
Immobiliser and Tyre Pressure Monitoring System (TPMS) Control Module. . . . .	10.14
Injector pulse time. . . . .	10.14
Lambda O2 Sensor . . . . .	10.14
Long term fuel trim. . . . .	10.14
MAP sensor . . . . .	10.14
MIL . . . . .	10.14
Open circuit . . . . .	10.14
Over temp . . . . .	10.14
Primary throttle position sensor. . . . .	10.14
Primary throttle stepper motor . . . . .	10.14
Purge valve duty cycle . . . . .	10.14
Road speed sensor . . . . .	10.14
Secondary air injection . . . . .	10.14
Sensor supply voltage . . . . .	10.14
Short circuit . . . . .	10.15
Short term fuel trim . . . . .	10.15
Sidestand status. . . . .	10.15
Target dwell time. . . . .	10.15
Throttle position. . . . .	10.15
Throttle voltage . . . . .	10.15
TDC. . . . .	10.15
TPMS . . . . .	10.15
Transponder. . . . .	10.15
Vbatt. . . . .	10.15
Engine Management System. . . . .	10.16
System Description . . . . .	10.16
System Sensors . . . . .	10.16
Sensor Locations . . . . .	10.17
System Actuators. . . . .	10.18
Actuator Locations. . . . .	10.19
Immobiliser System . . . . .	10.20
System Description . . . . .	10.20
System Components and Operation. . . . .	10.20
Keys. . . . .	10.20
Diagnostics . . . . .	10.20
Further Diagnosis. . . . .	10.20
Components Location. . . . .	10.21
Tyre Pressure Monitoring System (TPMS) . . . . .	10.22
System Description . . . . .	10.22
System Components and Operation. . . . .	10.22
Compliance . . . . .	10.22
Diagnostics . . . . .	10.22
Further Diagnosis. . . . .	10.22
Component Locations. . . . .	10.23
Engine Management Circuit Diagram - Tiger 800 . . . . .	10.24
Engine Management Circuit Diagram - Tiger 800 . . . . .	10.25
Engine Management Circuit Diagram - Tiger 800 XC . . . . .	10.26

Engine Management Circuit Diagram - Tiger 800 XC .....	10.27
System Diagnostics .....	10.28
On-board Fault Detection System .....	10.28
Diagnostic Tool Connection .....	10.29
Triumph Diagnostic Software .....	10.29
Build Data .....	10.29
Current Data .....	10.30
Sensor Data .....	10.31
Adaption Status .....	10.33
Function Tests .....	10.34
Adjust Tune .....	10.35
Freeze-frame Data .....	10.35
Diagnostic Trouble Codes .....	10.36
Electrical Connectors .....	10.39
Before Disconnection: .....	10.39
When Disconnecting a Connector: .....	10.39
When Inspecting a Connector: .....	10.39
When Connecting a Connector: .....	10.39
Disconnection of ECM connectors .....	10.39
Reconnection of ECM connectors .....	10.40
Further Diagnosis .....	10.40
Crankshaft Sensor .....	10.41
Idle Speed Control .....	10.42
Fuel Injectors .....	10.44
Throttle Position Sensor .....	10.46
Purge Valve .....	10.48
Ignition Coils .....	10.50
Coolant Temperature Sensor .....	10.52
Intake Air Temperature Sensor .....	10.54
System Voltage .....	10.56
Cooling Fan Relay .....	10.57
Oxygen Sensor .....	10.58
Oxygen Sensor Heater .....	10.59
EEPROM Error .....	10.60
Fall Detection Switch .....	10.61
Vehicle Speed Sensor .....	10.62
CAN Communication .....	10.63
Instrument Communication (CAN) .....	10.64
Fuel Level Sensor .....	10.65
Ambient (Barometric) Pressure Sensor .....	10.66
Manifold Absolute Pressure (Map) Sensor .....	10.67
Gear Position Sensor .....	10.68

# Fuel System/Engine Management

---

Fuel Pump .....	10.70
EMS Main Relay Circuit .....	10.72
EMS Ignition Voltage Input Circuit .....	10.74
5 Volt Sensor Supply Circuit .....	10.75
Tune Lock .....	10.76
ECM or Tune ID Incorrect .....	10.77
Immobiliser and TPMS Control Module Communication .....	10.78
Immobiliser and TPMS Control Module ID Incompatible .....	10.79
ABS Modulator ID Incompatible .....	10.80
ABS Modulator Communication .....	10.81
Fault Finding - Non Electrical .....	10.82
Front Wheel Unit Sensor Battery Alert .....	10.83
Rear Wheel Unit Sensor Battery Alert .....	10.84
Front Wheel Unit Sensor Fault Alert .....	10.85
Rear Wheel Unit Sensor Fault Alert .....	10.86
Front Wheel Unit Sensor Loss of Communication .....	10.87
Rear Wheel Unit Sensor Loss of Communication .....	10.88
Immobiliser/TPMS Control Module Fault .....	10.89
Invalid Key: Key Authentication Unsuccessful .....	10.90
Fuel Tank .....	10.91
Removal .....	10.91
Installation .....	10.92
Fuel Pump and Filter Assembly .....	10.93
Removal .....	10.93
Installation .....	10.94
Fuel Level Sender Assembly .....	10.95
Removal .....	10.95
Assembly .....	10.95
Fuel Pressure Checking .....	10.96
Fuel Delivery System .....	10.97
Airbox .....	10.98
Removal .....	10.98
Inspection .....	10.99
Installation .....	10.100
Air Filter Element .....	10.100
Removal .....	10.100
Installation .....	10.100
Intake Air Temperature Sensor .....	10.101
Removal .....	10.101
Installation .....	10.101
MAP Sensor .....	10.101

Removal .....	10.101
Installation.....	10.101
Barometric Pressure Sensor .....	10.102
Removal .....	10.102
Installation.....	10.102
Fall Detection Switch.....	10.102
Removal .....	10.102
Installation.....	10.102
Crankshaft Position Sensor.....	10.103
Removal .....	10.103
Installation.....	10.103
Immobiliser and TPMS Control Module.....	10.103
Removal .....	10.103
Installation.....	10.103
Ignition Switch and Immobiliser Antenna .....	10.104
Removal .....	10.104
Installation.....	10.104
Throttle Cable .....	10.104
Adjustment.....	10.104
Removal .....	10.105
Inspection.....	10.106
Installation.....	10.106
Throttle Bodies/Injectors.....	10.107
Removal .....	10.107
Inspection .....	10.108
Installation.....	10.109
Throttle Body Balancing .....	10.110
Throttle Position Sensor .....	10.112
Removal .....	10.112
Installation.....	10.112
Idle Speed Control Stepper Motor .....	10.113
Removal .....	10.113
Installation.....	10.114
Engine Management Adaption .....	10.116
General Information .....	10.116
Adaption Status .....	10.116
Terminology .....	10.116
Typical Values.....	10.117
Forcing adaption to take place.....	10.117
Exhaust System .....	10.118
Removal .....	10.118
Assembly.....	10.119

# Fuel System/Engine Management

---

Evaporative Emissions Control System.....	10.121
California Models Only.....	10.121
Component Locations.....	10.121
Evaporative Control System - Engine Off.....	10.122
Evaporative Control System - Engine Running.....	10.123



## Exploded View - Fuel Tank and Fuel Pump

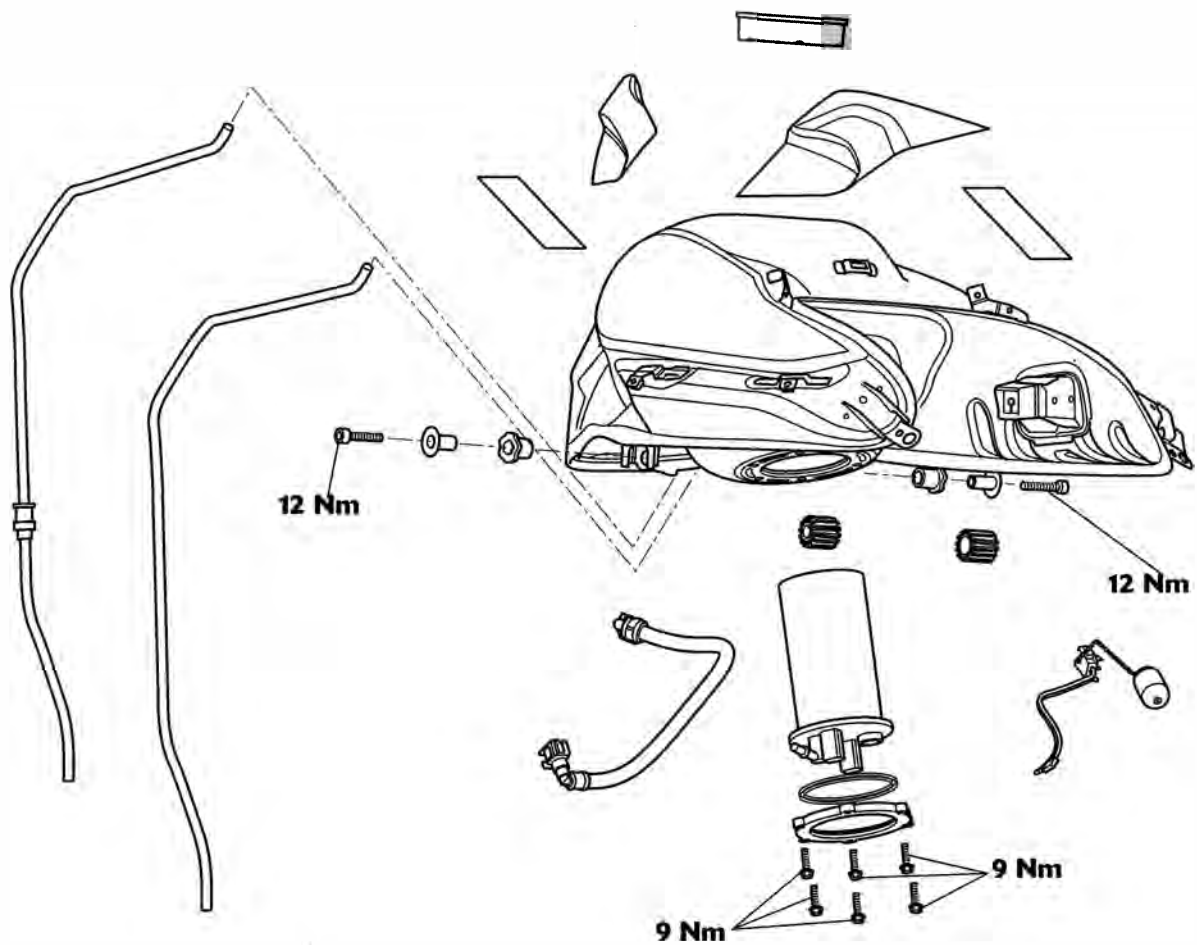

# Fuel System/Engine Management

## Exploded View - Fuel Rail, Throttles and Injectors

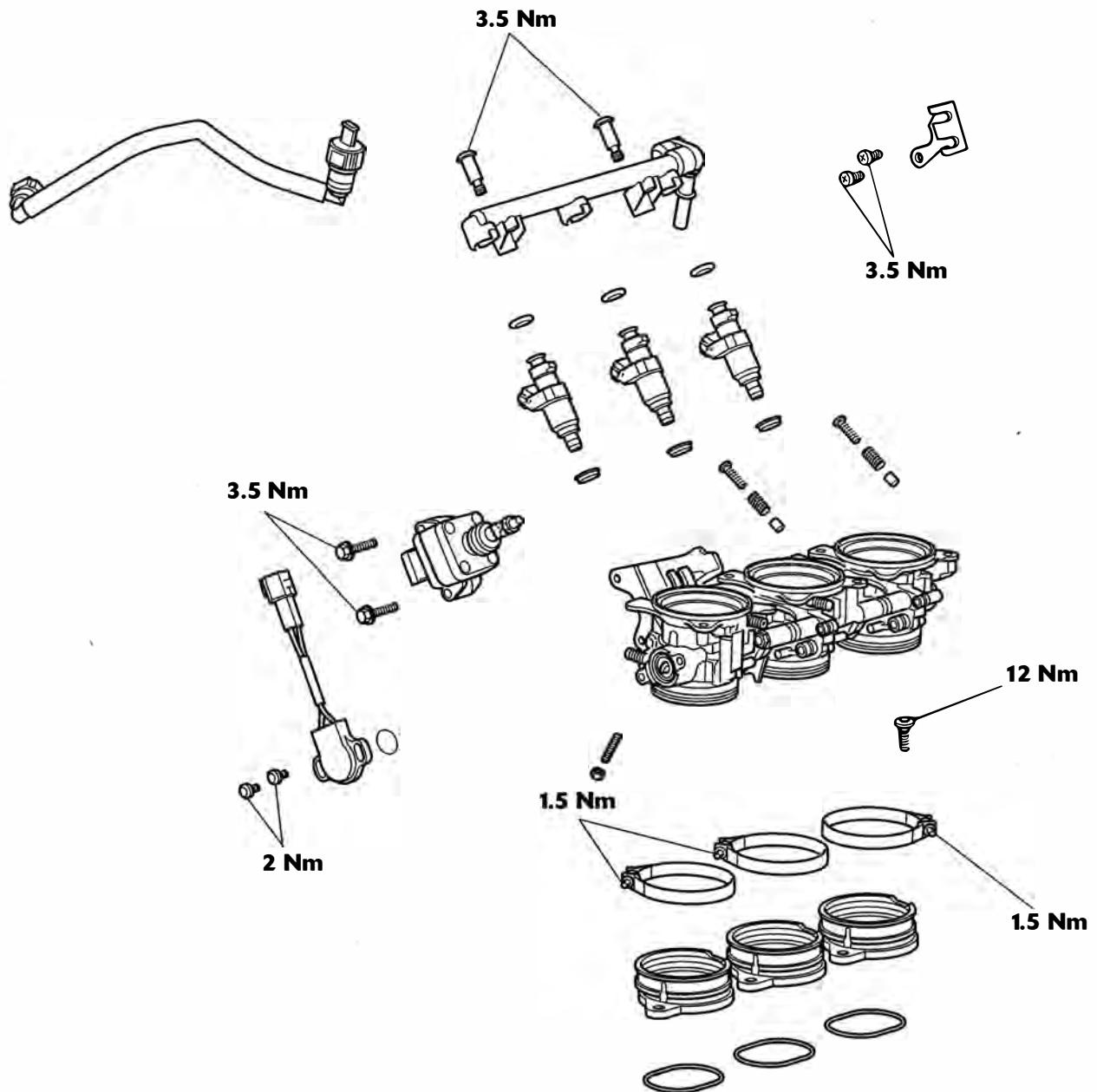

## Exploded View - Airbox

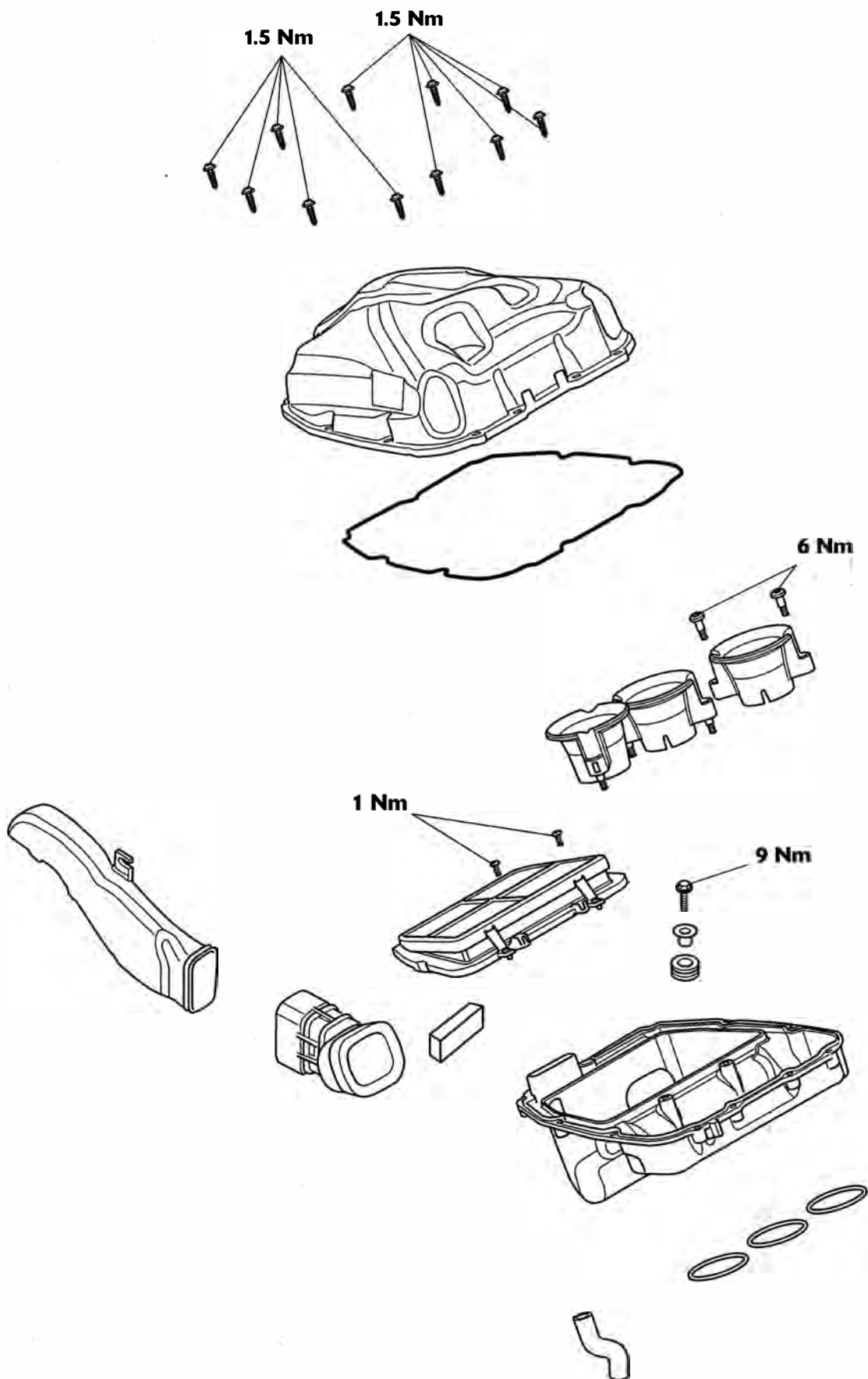

# Fuel System/Engine Management

## Exploded View - Exhaust System

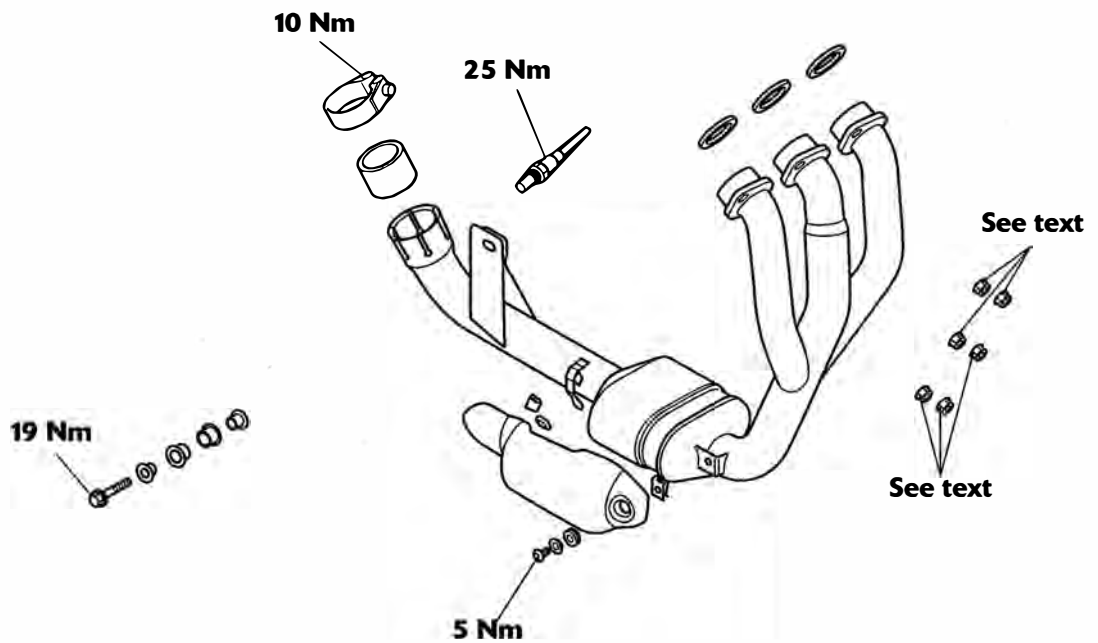
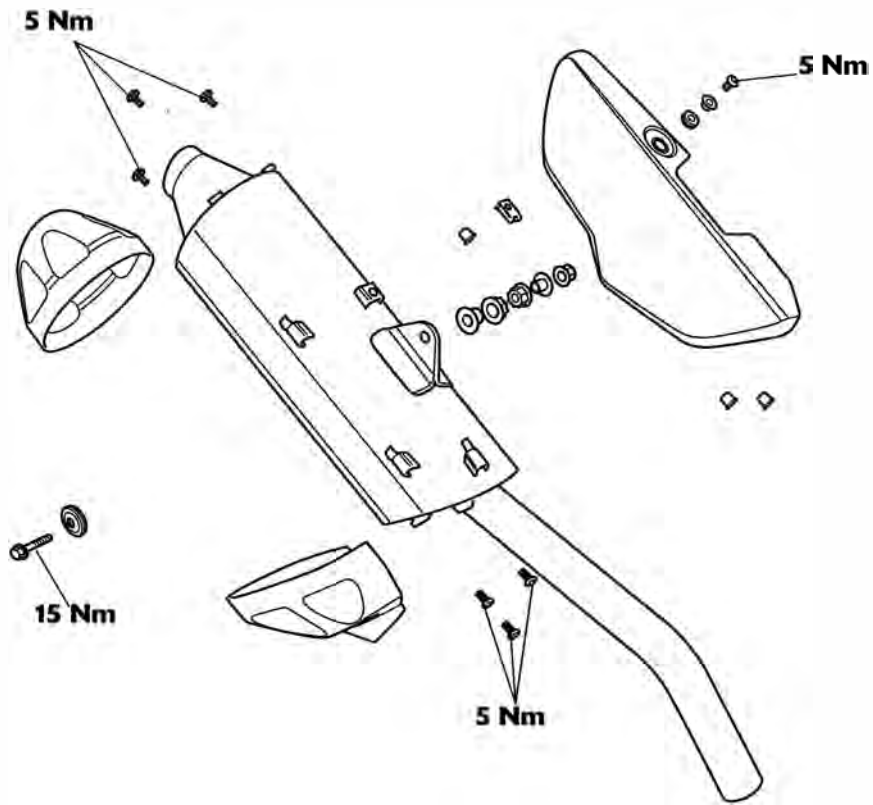

Exploded View - Evaporative System

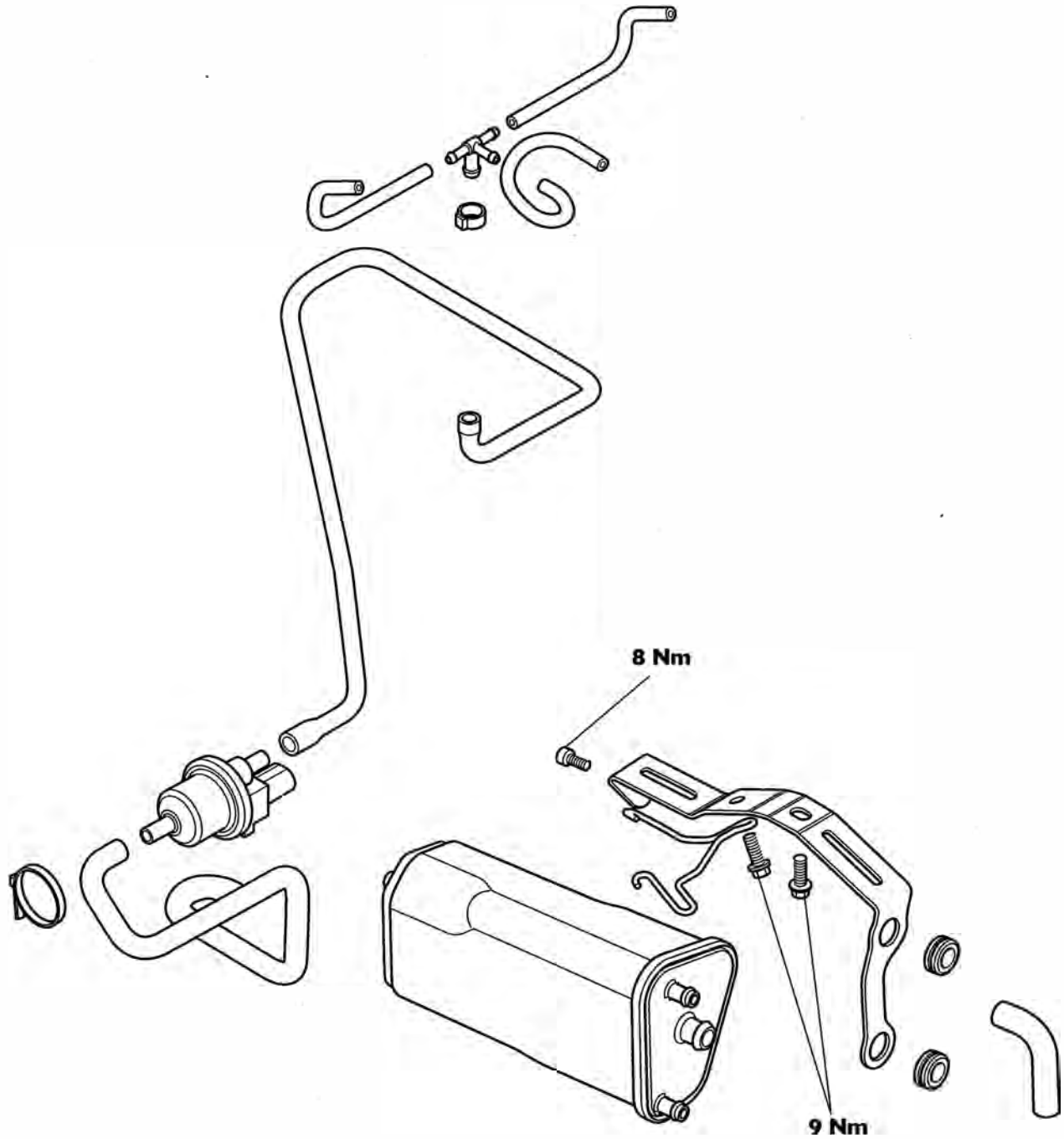

# Fuel System/Engine Management

---

## Fuel Requirements

### Fuel Requirements - all countries except USA

Outside of America, Tiger 800 and Tiger 800XC models must be run on 91 RON (or higher) unleaded fuel.

### Fuel Requirements - USA

In the United States of America where the octane rating of fuel is measured in a different way, the following information may be applied:

Tiger 800 and Tiger 800XC are designed to run on unleaded gasoline with a CLC or AKI octane rating  $(R+M)/2$  of 87 or higher.

#### Note:

- **If 'knocking' or 'pinking' occurs at a steady engine speed under normal load, use a different brand of gasoline or a higher octane rating.**

### Caution

The use of leaded gasoline is illegal in some countries, states or territories and will invalidate the vehicle and emissions control warranties. Additionally, leaded gasoline will cause damage to emissions control components.

### Oxygenated Gasoline

To help in meeting clean air standards, some areas of the U.S. use oxygenated gasoline to help reduce harmful emissions. This model will give best performance when using unleaded gasoline. However, the following should be used as a guide to the use of oxygenated fuels.

### Caution

Because of the generally higher volatility of oxygenated fuels, starting, engine response and fuel consumption may be adversely affected by their use. Should any of these difficulties be experienced, run the motorcycle on normal unleaded gasoline.

### Ethanol

Ethanol fuel is a mixture of 15% ethanol and 85% gasoline and is often described under the names 'gasohol', 'ethanol enhanced', or 'contains ethanol'. This fuel may be used in Triumph motorcycles.

### Methanol

### Caution

Fuels containing methanol should not be used in Triumph motorcycles as damage to components in the fuel system can be caused by contact with methanol.

### MTBE (Methyl Tertiary Butyl Ether)

The use of gasolines containing up to 15% MTBE (Methyl Tertiary Butyl Ether) is permitted in Triumph motorcycles.

## Glossary of Terms

The following terms and abbreviations will be found in this section. Below is given a brief explanation of what some of the more common terms and abbreviations mean.

### Air temperature

The air temperature in the air box and intake system.

### Air temperature sensor

Sensor located in the airbox to detect the temperature of the incoming air.

### ATDC

After Top Dead Centre (TDC).

### Barometric pressure

Pressure of the ambient air.

### Battery voltage

The voltage at the input to the Electronic Control Module (ECM).

### BTDC

Before Top Dead Centre (TDC).

### Catalyst

Device placed in the exhaust system which reduces exhaust emissions by stimulating secondary combustion of the exhaust gases.

### Closed throttle position

Throttle position at idle (i.e. against end stop), measured as a voltage and expressed as percentage.

### Coolant temperature

The coolant temperature in the cylinder head.

### Coolant temperature sensor

Sensor which detects coolant temperature.

### Cooling fan status

The 'on' or 'off' condition of the cooling fan.

### DTC

Diagnostic Trouble Code.

### ECM

Engine Control Module.

### Engine speed

The crankshaft revolutions per minute.

### Fall detection

The fall detection switch will detect if the motorcycle is on its side and will cut power to the ECM immediately.

### Freeze frame

A data set captured at the time a Diagnostic Trouble Code (DTC) is set.

### Gear position sensor

Gearbox mounted sensor which delivers information to the ECM. This is converted to the gear position value that is displayed on the instrument's gear position indicator and/or neutral lamp.

### Idle fuel trim

The percentage above or below the nominal fuel requirement for the volume of air entering at idle.

# Fuel System/Engine Management

---

## Idle fueling

Adjustment of fueling at idle to suit the actual air inducted.

## Idle reference speed

The target idle speed as determined by the Electronic Control Module (ECM). (It should be the same as the actual idle speed if the motorcycle is operating correctly.)

## Ignition advance

The timing of the ignition at the spark plug relative to top dead centre (TDC).

## Ignition switch position

The 'ON' or 'OFF' position of either or both the ignition switch and the engine stop switch.

## Ignition timing

Same as 'ignition advance'.

## Immobiliser and Tyre Pressure Monitoring System (TPMS) Control Module

The control module for the Immobiliser and TPMS system.

## Injector pulse time

The time during which an injector remains open (i.e. delivering fuel).

## Lambda O<sub>2</sub> Sensor

The Lambda sensor measures the Oxygen levels in the exhaust gases and feeds this information to the ECM. Based on this information, adjustments to air/fuel ratio are made.

## Long term fuel trim

Fueling after adapting to the engine's long term fueling requirements (closed loop only). See also short term fuel trim.

## MAP sensor

Manifold Absolute Pressure (the air pressure in the intake system). Measured after the throttle valves. This reading is compared to the ambient pressure reading to allow the ECM to calculate engine load.

## MIL

Malfunction Indicator Lamp.

Illuminates when most Diagnostic Trouble Codes (DTCs) are set.

## Open circuit

A break in an electrical circuit - current cannot flow.

## Over temp

High temperature within the Electronic Control Module (ECM) caused by an internal or external failure.

## Primary throttle position sensor

Sensor for the primary (lower) throttle position.

## Primary throttle stepper motor

Stepper motor used to vary throttle opening at idle and when the engine is cold.

## Purge valve duty cycle

The time the purge valve is open in an open/close cycle, expressed as a percentage of the cycle time.

## Road speed sensor

Gearbox mounted sensor which delivers information to the ECM. This is converted to the road speed value that is then displayed on the speedometer.

Non ABS models only. ABS models use the rear ABS wheel speed sensor to supply road speed sensor to the ECM.

## Sensor supply voltage

Supply voltage to the system sensors (nominally 5 Volts).



## Short circuit

A 'short cut' in an electrical circuit - current by-passes the intended circuit (usually to earth).

## Short term fuel trim

A correction applied to the fuel mixture during closed loop catalyst operation. This, in turn has an effect on the long term fuel trim in that, if an engine constantly requires mixture correction, the long term fuel trim will adapt to this requirement thus reducing the need for constant short term adjustment.

## Sidestand status

The 'up' or 'down' position of the side stand.

## Target dwell time

The actual time from coil 'on' to coil 'off'.

## Throttle position

The position of the throttle butterfly given as a percentage of the movement range. When the data is displayed on the diagnostic software, fully open need not be 100% nor fully closed 0%.

## Throttle voltage

Voltage at the throttle potentiometer.

## TDC

Top Dead Centre.

## TPMS

Tyre Pressure Monitoring System.

## Transponder

A transmitter-responder chip located in the ignition key. The transponder is activated by a radio signal sent out by the immobiliser and TPMS control module, via an antenna located around the ignition switch. If the immobiliser and TPMS control module does not receive the correct code signal from the transponder, the immobiliser will remain active and the engine will not start.

## Vbatt

Battery voltage.

## Engine Management System

### System Description

The Tiger 800 and Tiger 800XC models are fitted with an electronic engine management system which encompasses control of both ignition and fuel delivery. The electronic control module (ECM) draws information from sensors positioned around the engine, cooling and air intake systems and precisely calculates ignition advance and fueling requirements for all engine speeds and loads.

In addition, the system has an on-board diagnostic function. For additional information, see page 10-28.

### System Sensors

- **Intake air temperature sensor** - situated in the top of the airbox. As the density of the air (and therefore the amount of oxygen available to ignite the fuel) changes with temperature, an intake air temperature sensor is fitted. Changes in air temperature (and therefore air density) are compensated for by adjusting the amount of fuel injected to a level consistent with clean combustion and low emissions.
- **Barometric pressure sensor** - situated below the battery. The barometric pressure sensor measures atmospheric air pressure. With this information, the amount of fuel injected is adjusted to suit the prevailing conditions.
- **Manifold Absolute Pressure (MAP) sensor** - situated to the front of the airbox, connected to each of the three throttle bodies by equal length tubes. The MAP sensor provides information to the ECM which is used at shallow throttle angles (very small throttle openings) to provide accurate engine load indications to the ECM. This degree of engine load accuracy allows the ECM to make very small adjustments to fuel and ignition which would otherwise not be possible from throttle angle data alone.
- **Clutch switch** - situated on the clutch lever. The clutch must be pulled in for the starter motor to operate.
- **Crankshaft position sensor** - situated in the alternator cover. The crankshaft position sensor detects movement of teeth attached to the alternator rotor.  
The toothed rotor gives a reference point from which the actual crankshaft position is calculated. The crankshaft position sensor information is used by the ECM to determine engine speed and crankshaft position in

relation to the point where fuel is injected and ignition of the fuel occurs.

- **Engine coolant temperature sensor** - situated at the rear of the cylinder head. Coolant temperature information, received by the ECM, is used to optimise fueling at all engine temperatures and to calculate hot and cold start fueling requirements.
- **Throttle position sensor** - situated at the right end of the throttle body. Used to relay throttle position information to the ECM. Throttle opening angle is used by the ECM to determine fueling and ignition requirements for all throttle positions.
- **Road speed sensor** - situated in the upper crankcase, in front of the engine breather. The road speed sensor provides the ECM with data from which road speed is calculated and displayed on the speedometer.
- **Lambda sensor** - situated in the exhaust header system upstream of the catalyst. The lambda sensor constantly feeds information to the ECM on the content of the exhaust gases. Based on this information, adjustments to the air/fuel ratio are made.
- **Side stand switch** - situated at the top of the sidestand leg. If the sidestand is in the down position, the engine will not run unless the transmission is in neutral.
- **Gear position sensor** - situated in the upper crankcase, behind the gearbox output sprocket cover, on the left hand side of the engine. The gear position sensor provides the ECM with selected gear information. This is used to prevent the engine from starting if the transmission is in gear. The sensor also provides information to the gear position indicator and the neutral lamp in the instruments.
- **Fall detection switch** - situated on the relay and fuse box bracket below the fuel tank. The fall detection switch will detect if the motorcycle is on its side and will cut power to the ECM immediately. This prevents the engine from running and the fuel pump from delivering fuel. In the event of a fall, the switch is reset by returning the bike to an upright position and switching the ignition off then back on again.

## Sensor Locations

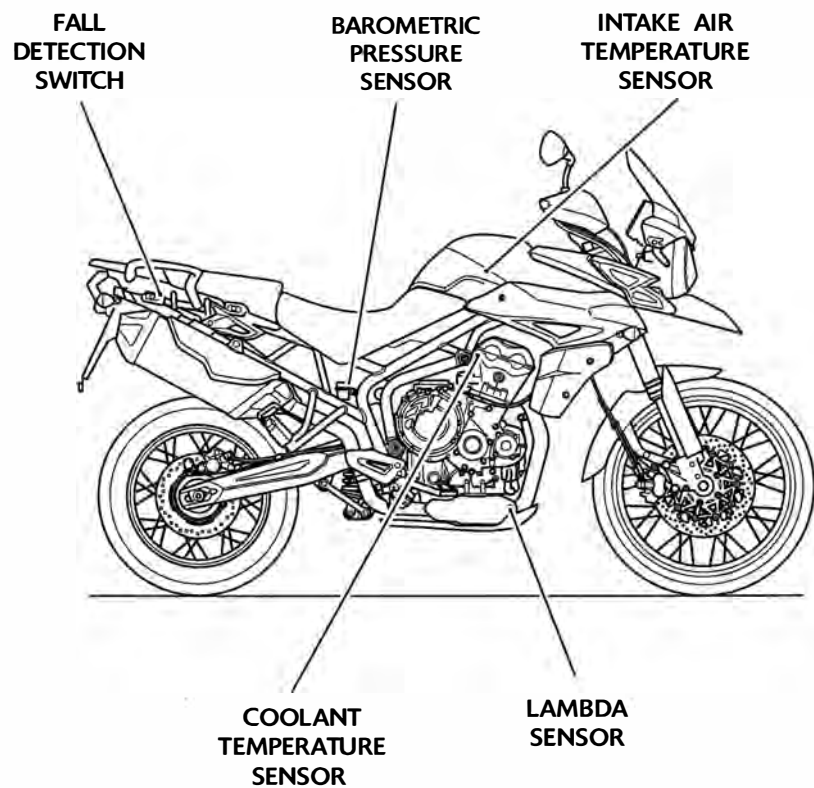
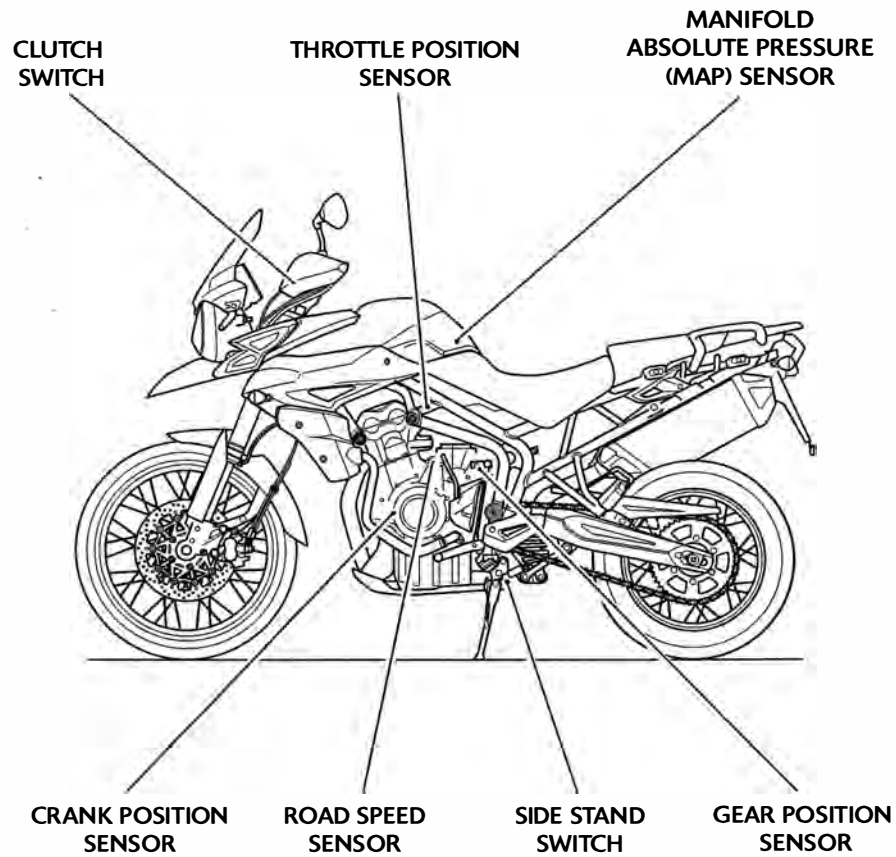

# Fuel System/Engine Management

---

## System Actuators

In response to signals received from the sensors, the ECM controls and directs messages to a series of electronic and electro-mechanical actuators. The function and location of the actuators is given below.

- **Throttle stepper motor** - situated between the throttle bodies of cylinders two and three. The throttle stepper actuates a cam/lever which causes variations in the closed throttle position. Although used primarily to ensure target idle speed is maintained, it also increases throttle opening when the engine is cold.
- **Canister purge valve (California models only)** - situated in the vapour return line between the carbon canister and the throttle bodies. The purge valve controls the return of vapour which has been stored in the carbon canister during the period when the engine is switched off. The valve is 'pulsed' by the ECM to give control over the rate at which the canister is purged.
- **Injectors** - located on the throttle body. The engine is fitted with three injectors. The spray pattern of the injectors is fixed but the length of time each injector can remain open is variable according to operating conditions. The duration of each injection is calculated by the ECM using data received from the various sensors in the system.
- **Ignition coils** - plug-top coils are located in the cam cover. There are three coils fitted, one for each spark plug. The ECM controls the point at which the coils are switched on and off. In calculating the switch-on time, the ECM allows sufficient time for the coils to charge to a level where a spark can be produced. The coils are switched off at the point of ignition, the timing of which is optimised for good engine performance.
- **EMS main relay** - situated behind the battery. When the ignition is switched on, the EMS main relay is powered up to provide a stable voltage supply for the ECM. When the ignition is turned off, the ECM carries out a power down sequence during which the EMS main relay remains powered by the ECM for 1 minute. The ECM power down sequence includes: writing the adaption data to ECM memory and referencing the position of the throttle stepper motor.
- **Fuel pump** - located inside the fuel tank. The electric pump delivers fuel into the fuel system, via a pressure regulator, at a constant 3 bar pressure. The pump is run continuously

when the engine is operating and is also run briefly when the ignition is first switched on to ensure that 3 bar is available to the system as soon as the engine is cranked. Fuel pressure is controlled by a regulator also situated inside the fuel tank.

- **Cooling fan** - located behind the radiator. The ECM controls switching on and off of the cooling fan in response to a signal received from the coolant temperature sensor. When the coolant temperature rises to a level where the cooling effect of natural airflow is insufficient, the cooling fan is turned on by the ECM. When the coolant temperature falls sufficiently, the ECM turns the cooling fan off. The fan only becomes operational when the engine is running. It will not operate at any other time.

### Note:

- **In this system, the starter lockout system (clutch switch, gear position sensor, sidestand switch) all operate through the engine management ECM.**

## Actuator Locations

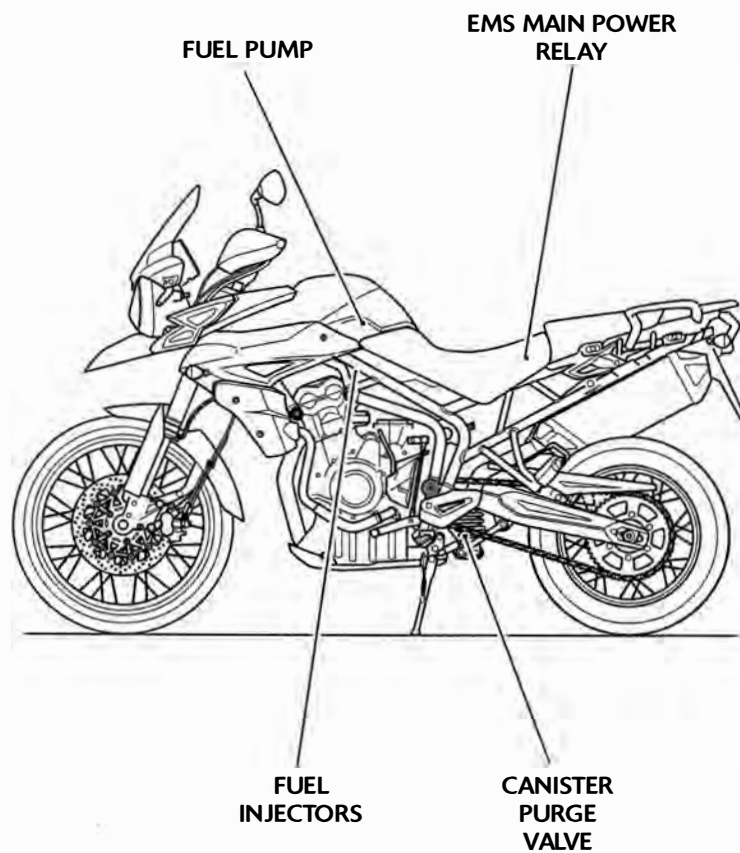
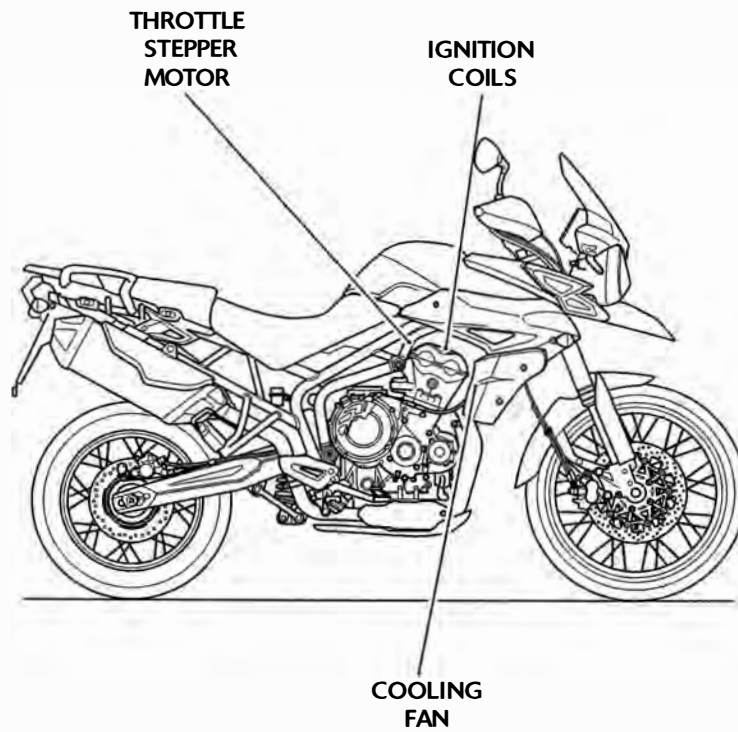

## Immobiliser System

### System Description

The Tiger 800 and Tiger 800XC models are fitted with an electronic immobiliser system to help protect against theft. This system has to be paired with the ECM and the ignition key which contains a transponder chip. If all the components are correctly paired, the immobiliser will allow the engine to start. The Triumph diagnostic tool is the only way these components can be paired.

In addition, the system has an on-board diagnostic function. This ensures that, should a malfunction occur in the immobiliser system, a malfunction code is stored in the immobiliser/tyre pressure monitoring system (TPMS) control modules memory. This stored data can then be recovered using the Triumph diagnostic tool (see page 10-28).

### System Components and Operation

- **Transponder chip** - Situated inside the ignition key. The chip is activated by the antenna coil when the ignition switch is turned to the ON position.
- **Antenna coil** - Situated around the ignition switch. When the ignition switch is turned to the ON position, and the transponder chip is activated, the signal from the chip is sent to the immobiliser/TPMS control module.
- **Immobiliser/TPMS Control Module** - Situated under the headstock. This control module communicates with the transponder chip in the key and the ECM and will only allow the engine to start if a matching signal is received.
- **Alarm/immobiliser warning indicator light** - Situated in the instrument pack. The light will flash on and off for 24 hours to show that the engine immobiliser is on. When the ignition switch is turned to the ON position the immobiliser and the indicator light will be off. If the indicator light remains on it indicates that the immobiliser has a malfunction that requires investigation. If an accessory alarm is fitted, the immobiliser indicator light will only illuminate when the conditions described in the accessory alarm instructions are met.

### Keys

When the motorcycle is delivered from the factory it is supplied with two keys. Keys can be deleted or added to the immobiliser system using the Triumph diagnostic tool. A maximum of four keys can be added to the system.

To ensure the immobiliser system functions correctly note the following:

- Do not put any magnetic materials on the same key ring as the motorcycle key;
- Do not put any other ignition key with a transponder chip fitted near the motorcycle key when in use;
- Do not modify the immobiliser system;
- Do not submerge the key in water or any other fluid;
- Do not drop or strike the key against hard material.

### Diagnostics

To fully diagnose the immobiliser system it is necessary to check for fault codes in the immobiliser/TPMS control module using the Triumph diagnostic tool (see page 10-28).

### Further Diagnosis

The tables that start on page 10-41, if used correctly, help to pinpoint a fault in the system once a diagnostic trouble code has been stored.

## Components Location

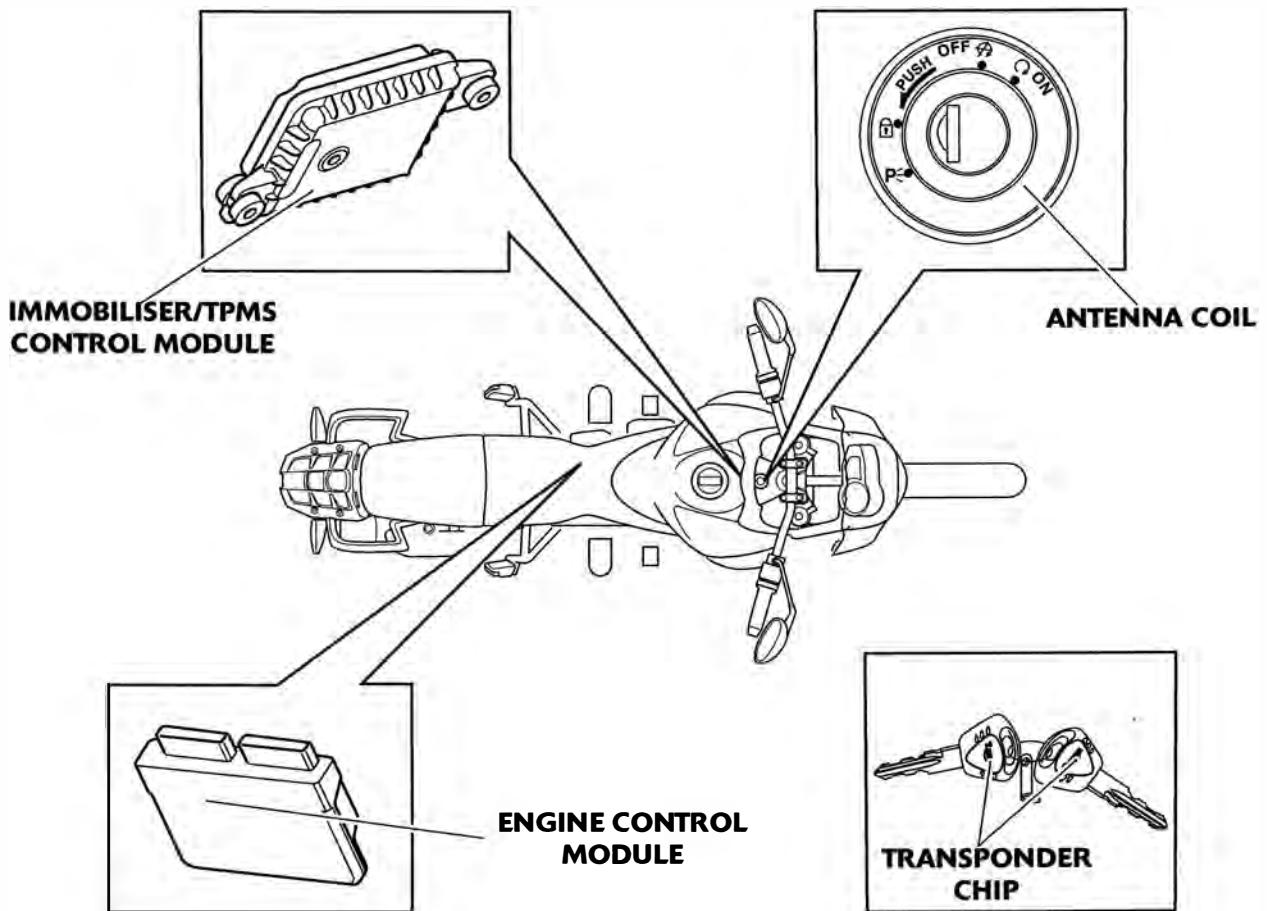

## Tyre Pressure Monitoring System (TPMS)

### System Description

The Tiger 800 can be fitted with the accessory tyre pressure monitoring system (TPMS).

When fitted the tyre pressures shown on the instrument panel indicate the actual tyre pressure at the time of selecting the display. This may differ from the inflation pressure set when the tyres are cold because tyres become warmer during riding, causing the air in the tyre to expand and the pressure to increase. The cold inflation pressures specified by Triumph take account of this.

In addition, the system has an on-board diagnostic function. This ensures that, should a malfunction occur in the immobiliser system, a malfunction code is stored in the immobiliser/tyre pressure monitoring system (TPMS) control modules memory. This stored data can then be recovered using the Triumph diagnostic tool (see page 10-28).

Owners must only adjust tyre pressures when the tyres are cold using an accurate tyre pressure gauge and must not use the tyre pressure display on the instruments.

 **Warning**

The tyre pressure monitoring system is not to be used as a tyre pressure gauge when adjusting the tyre pressures. For correct tyre pressures, always check the tyre pressures when the tyres are cold and using an accurate tyre pressure gauge.

Use of the TPMS system to set inflation pressures may lead to incorrect tyre pressures leading to loss of motorcycle control and an accident.

When fitting the TPMS, the installation flow-chart detailed in the Triumph diagnostic tool user guide must be followed.

### System Components and Operation

- **Instruments** - Used to display the tyre pressure value, the tyre symbol and the TPMS warning light.
- **Immobiliser/TPMS control module** - Receives the data from the tyre pressure sensors and sends the information to the instrument pack.

- **Tyre pressure sensor** - Situated inside the front and rear wheel. Each sensor has its own unique ID number and must be recorded in the spaces provided in the owner's handbook. These sensors measure the air pressure inside the tyre and transmit pressure data to the instruments. These sensors will not transmit the data until the motorcycle is travelling at a speed greater than 12 mph (20 km/h). Two dashes will be visible in the display area until the tyre pressure signal is received. The wheel sensor is a sealed unit and must not be opened. The battery inside the sensor is not replaceable and a new sensor must be fitted when the battery voltage becomes too low.

### Compliance

This device complies with part 15 of the FCC Rules.

Operation is subject to the following two conditions:

- This device may not cause harmful interference;
- This device must accept any interference received, including interference that may cause undesired operation.

Changes or modifications to the device could void the user's authority to operate the equipment.

### Diagnostics

When a fault condition with the TPMS is detected, the red warning light in the instrument pack will illuminate and the tyre symbol will flash repeatedly.

The red warning light and flashing symbol will also occur if the TPMS has been enabled in the instrument pack but not in the immobiliser/TPMS control module. Before proceeding to the diagnostics, check that the motorcycle has wheel sensors fitted and that the option for the TPMS has been enabled in the immobiliser/TPMS control module.

### Further Diagnosis

The tables that start on page 10-41, if used correctly, help to pinpoint a fault in the system once a diagnostic trouble code has been stored.



## Component Locations

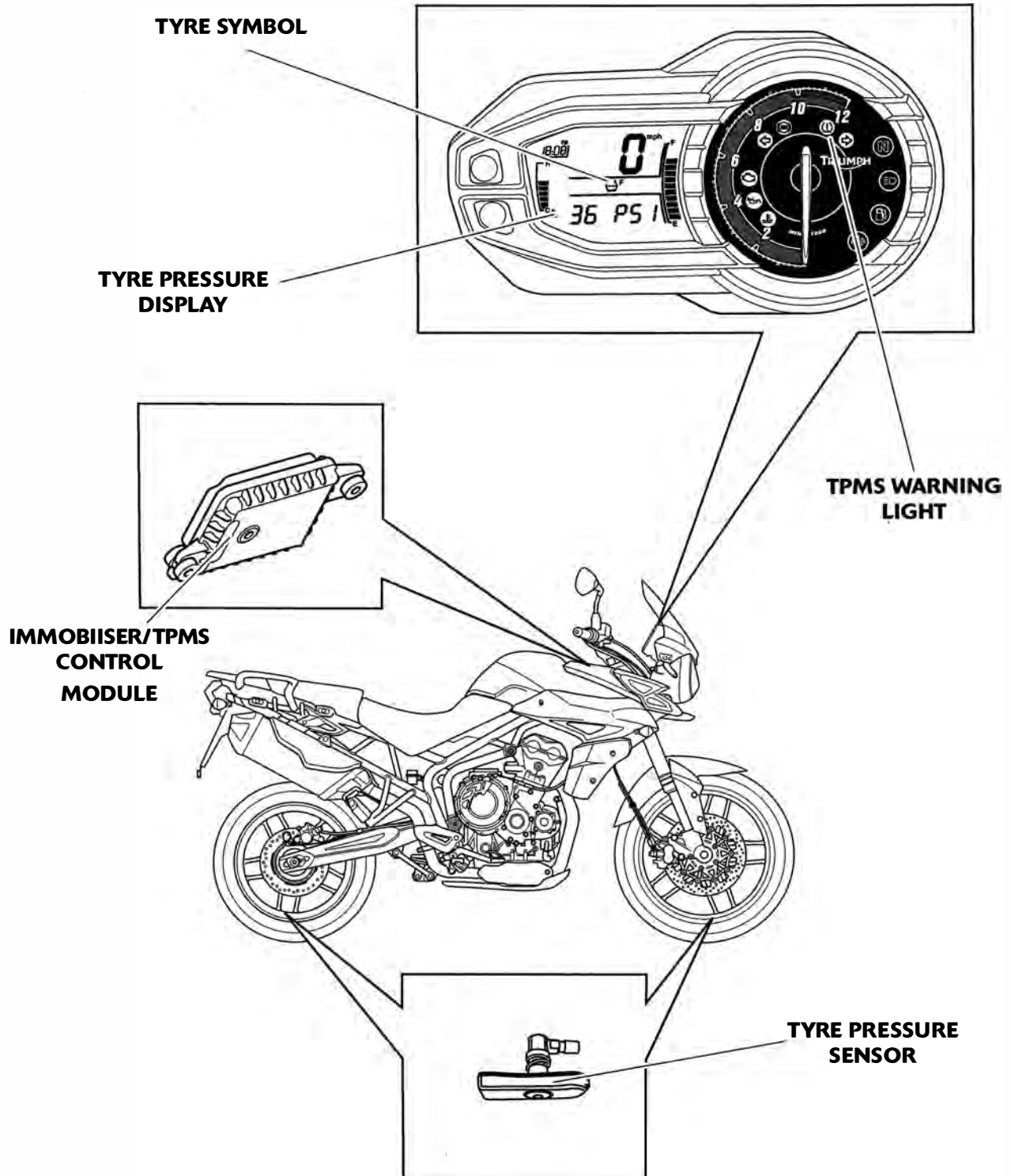

# Fuel System/Engine Management

## Engine Management Circuit Diagram - Tiger 800 and Tiger 800XC

### Key To Wiring Circuit Diagram

Key	Item Description
1	Engine Control Module
2	Diagnostic Connector
3	Road Speed Sensor
4	Instrument Assembly
5	Clutch Switch
6	Immobiliser
7	Sidestand Switch
8	Ignition Switch
9	Fuel Level Sensor
10	Fall Detection Switch
11	Barometric Pressure Sensor
12	Intake Air Temperature Sensor
13	MAP Sensor
14	Coolant Temperature Sensor
15	Oxygen (Lambda) Sensor
16	Throttle Position Sensor
17	Gear Position Sensor
18	Fuel Pump
19	Fuel Pump Relay
20	Cooling Fan
21	Cooling Fan Relay
22	Idle Speed Control Stepper Motor
23	Coil 3
24	Coil 2
25	Coil 1
26	Oxygen (Lambda) Sensor Heater
27	Fuel Injector 3
28	Fuel Injector 2
29	Fuel Injector 1
30	Purge Valve
31	Crankshaft Position Sensor
32	Engine Control Module Relay

### Key To Wiring Colour Codes

Code	Wiring Colour
B	Black
U	Blue
N	Brown
G	Green
S	Slate/Grey
O	Orange
K	Pink
R	Red
P	Purple
W	White
Y	Yellow
LG	Light Green
LU	Light Blue

### ECM Connector Pin Numbering

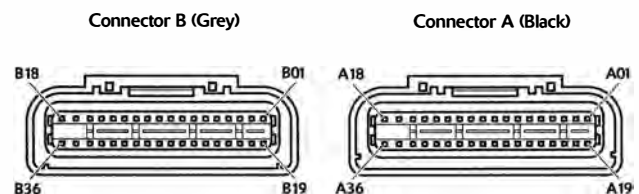

The above illustration shows the pin numbering system used in the engine management circuit diagram.

The black connector's pins are prefixed A and the grey connector's pins B. As viewed from the mating face with the ECM (as per the illustration), pins are numbered from right to left with number one in the top right corner.

## Engine Management Circuit Diagram - Tiger 800 and Tiger 800XC

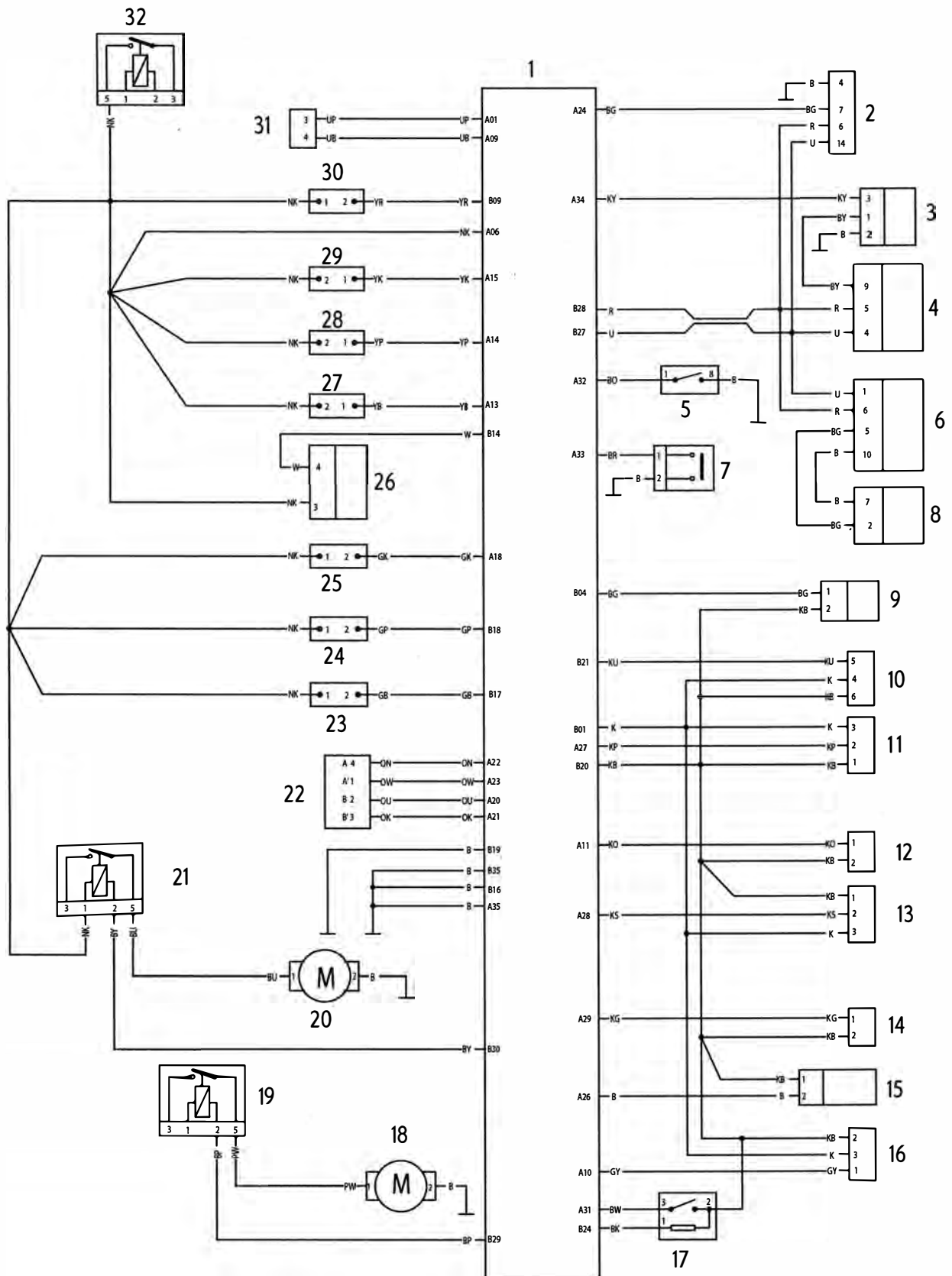

# Fuel System/Engine Management

## Engine Management Circuit Diagram - Tiger 800 (ABS) and Tiger 800XC (ABS)

### Key To Wiring Circuit Diagram

Key	Item Description
1	Engine Control Module
2	Diagnostic Connector
3	ABS Modulator
4	Instrument Assembly
5	Clutch Switch
6	Immobiliser
7	Sidestand Switch
8	Ignition Switch
9	Fuel Level Sensor
10	Fall Detection Switch
11	Barometric Pressure Sensor
12	Intake Air Temperature Sensor
13	MAP Sensor
14	Coolant Temperature Sensor
15	Oxygen (Lambda) Sensor
16	Throttle Position Sensor
17	Gear Position Sensor
18	Fuel Pump
19	Fuel Pump Relay
20	Cooling Fan
21	Cooling Fan Relay
22	Idle Speed Control Stepper Motor
23	Coil 3
24	Coil 2
25	Coil 1
26	Oxygen (Lambda) Sensor
27	Fuel Injector 3
28	Fuel Injector 2
29	Fuel Injector 1
30	Purge Valve
31	Crankshaft Position Sensor
32	Engine Control Module Relay

### Key To Wiring Colour Codes

Code	Wiring Colour
B	Black
U	Blue
N	Brown
G	Green
S	Slate/Grey
O	Orange
K	Pink
R	Red
P	Purple
W	White
Y	Yellow
LG	Light Green
LU	Light Blue

### ECM Connector Pin Numbering

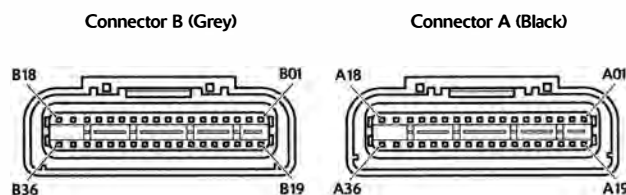

The above illustration shows the pin numbering system used in the engine management circuit diagram.

The black connector's pins are prefixed A and the grey connector's pins B. As viewed from the mating face with the ECM (as per the illustration); pins are numbered from right to left with number one in the top right corner.

## Engine Management Circuit Diagram - Tiger 800 (ABS) and Tiger 800XC (ABS)

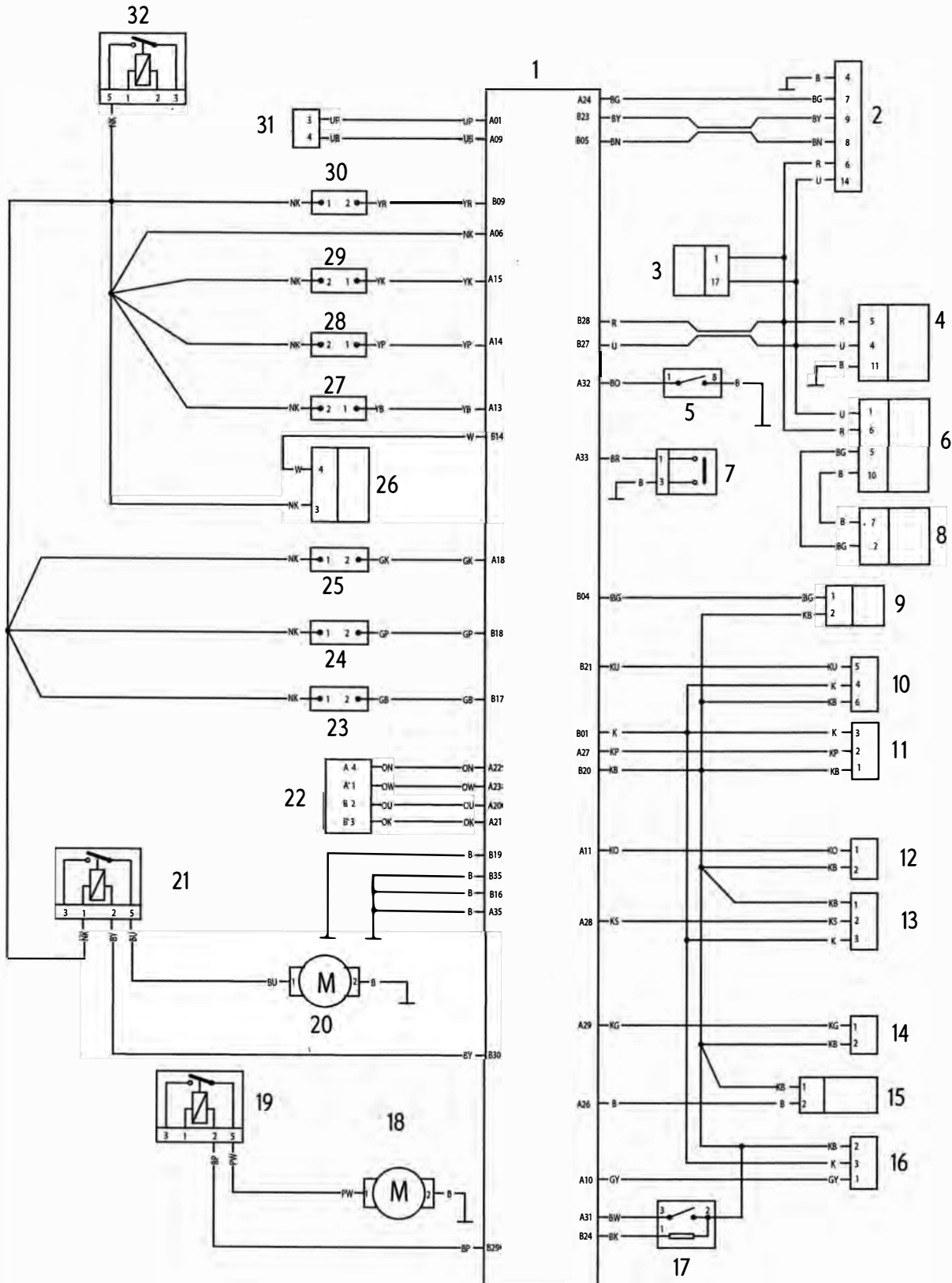

## System Diagnostics

The engine management system has an on-board diagnostics feature which allows service technicians to retrieve stored data from the ECM using the Triumph diagnostic software. **Full details of the Triumph diagnostic software operation and how to interpret the results are given in the Triumph Diagnostic Tool User Guide.**

The software is connected, via an interface cable, to the motorcycle using a dedicated diagnostic plug situated beneath the seats. By using a dedicated plug, no electrical connectors associated with the system are disturbed, reducing potential connector damage.

The software allows the user to retrieve data associated with the system sensors and actuators, test various component functions, read build data and make minor adjustments to the set-up of the system. The data and tests available are described on the following pages.

## On-board Fault Detection System

The on-board diagnostic system has two stages to fault detection. When a fault is detected, the DSM (Diagnostic Status Manager) raises a flag to indicate that a fault is present and increments a counter. The counter checks the number of instances that the fault is noted. For example, if there is a fault in the crankshaft position sensor, the counter will increment its count each time the crankshaft turns through 360°, provided the fault is still present.

When the count begins, the fault is detected but not confirmed. If the fault continues to be detected and the count reaches a pre-determined threshold, the fault becomes confirmed. If the fault is an emissions related fault or a serious malfunction affecting engine performance, a DTC (Diagnostic Trouble Code) and freeze-frame data will be logged in the ECM's memory and the MIL (Malfunction Indicator Lamp) on the motorcycle instrument panel is illuminated. Once a fault is confirmed, the number of warm-up cycles made by the engine is counted. If the fault clears, the warm-up cycle counter will extinguish the MIL (Malfunction Indicator Lamp) at a pre determined count, and erase the DTC and freeze frame data from the ECM memory at another (higher) count.

A single warm-up cycle is deemed to have taken place when the following criteria have been met:

- The coolant temperature must be raised to 72° C or more.
- The coolant temperature must have risen by 23° C or more from its start temperature, when 72° C is reached.
- A controlled power-down sequence must take place.

### Note:

- **When a fault has been rectified, the MIL will remain illuminated until sufficient non-fault warm-up cycles have taken place to turn it off. The MIL will be immediately extinguished if, after first rectifying the fault, the DTC (diagnostic trouble code) that caused the MIL illumination is erased from the ECM memory using the Triumph diagnostic software.**

### Note:

- **In most cases, when a fault is detected, the engine management system will revert to a 'limp-home' mode. In this mode, the engine will still function though the performance and fuel economy may be marginally affected. In some cases, the rider may not notice any appreciable difference from normal operation.**

## Diagnostic Tool Connection

1. To connect the Triumph diagnostic interface to the motorcycle, remove the pillion seat (see page 16-13) and release the diagnostic connector from its locating tang.
2. Plug the diagnostic interface directly in to the diagnostic connector.

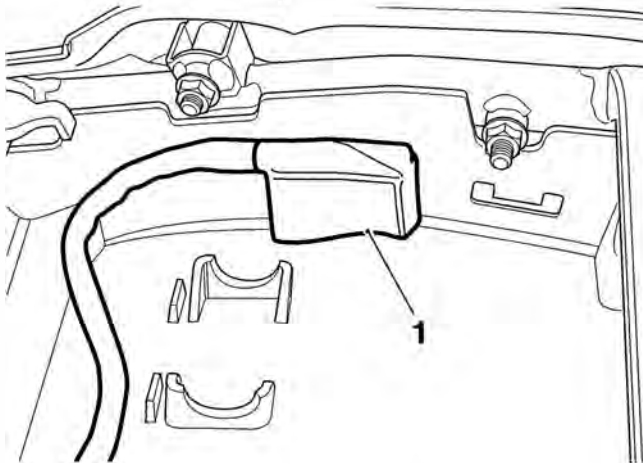

1. Diagnostic connector

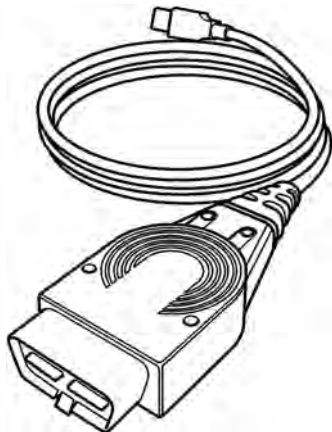

### Diagnostic Interface

3. When the diagnostic session is completed, disconnect the Triumph diagnostic interface.
4. Refit the diagnostic connector to its locating tang and refit the pillion seat (see page 16-13).

## Triumph Diagnostic Software

Described on the following pages is the range of information which can be retrieved from the ECM's memory and the adjustments which can be performed using the Triumph diagnostic software.

The tables indicate which tests are performed by the on-board system and what information can be retrieved by the Triumph diagnostic software.

### Note:

- Full details of how to operate the software and how to interpret the data can be found in the Triumph Diagnostic Tool User Guide, which can be downloaded by authorised Triumph dealers from [www.triumphonline.net](http://www.triumphonline.net).

### Build Data

The **Build Data** screen will display the following information:

- Motorcycle model;
- Vehicle Identification Number (VIN);
- ECM type;
- ECM ID;
- ECM serial number;
- Tune number;
- Date of last tune download;
- Total tune downloads since manufacture;
- The lock status of the ECM (ECM Locked, Unlocked or Not Applicable).

# Fuel System/Engine Management

---

## Current Data

The data available under Current Data is:

<b>Function Examined</b>	<b>Result Reported (Scale)</b>
Fuel system status 1	open or closed loop operation
Calculated load value	%
Engine coolant temperature	°C
Short term fuel trim - Bank 1	%
Intake manifold absolute pressure	mm/hg
Engine speed	RPM
Vehicle speed	km/h
Ignition timing advance - cylinder 1	degrees
Intake air temperature	°C
Absolute throttle position	%
Bank 1 - oxygen sensor 1	Volts
Bank 1 - oxygen sensor 1 - short term fuel trim	%



## Sensor Data

When using this function it is possible to check the status of various sensors and actuators.

The data sets are divided into seven groups - Sensor Voltages; Sensor Readings; Injector Data; Ignition Data; Idle Speed, Throttle Data and Inputs and Adaption Status. Each of these screens is described on the following pages.

### Sensor Voltages

The data available under sensor voltages is:

Item Checked	Result Unit
Battery voltage	Volts
Voltage from ignition switch to ECU	Volts
Air temperature sensor voltage	Volts
Coolant temperature sensor voltage	Volts
Atmospheric pressure sensor voltage	Volts
Manifold absolute pressure sensor 1 voltage	Volts
Manifold absolute pressure sensor 2 voltage	Volts
Throttle position sensor voltage	Volts
Fuel level sensor voltage	Volts
Oxygen sensor 1 output voltage	Volts

### Sensor Readings

The data available under sensor readings is:

Item Checked	Result Unit
Air temperature	°C
Coolant temperature	°C
Atmospheric (barometric) pressure	mmHg
Short term fuel trim‡	%
Manifold absolute pressure (one reading per cylinder)	mmHg
Low fuel light	on/off
Oxygen sensor 1 short term fuel trim	%
Oxygen sensor 1 heater status	on/off

# Fuel System/Engine Management

---

## Injector Data

The data available under injector data is:

Item Checked	Result Unit
Injector 1 pulse time	milliseconds
Injector 2 pulse time	milliseconds
Injector 3 pulse time	milliseconds

## Ignition Data

The data available under ignition data is:

Item Checked	Result Unit
Ignition timing cyl 1	degrees BTDC
Ignition timing cyl 2	degrees BTDC
Ignition timing cyl 3	degrees BTDC
Coil dwell time	milliseconds

## Idle Speed and Throttle Data

The data available under idle speed and throttle data is:

Item Checked	Result Unit
Engine speed	RPM
Idle reference speed	RPM
Idle speed control current steps	numeric
Idle speed control target steps	numeric
Throttle position	% open

# Fuel System/Engine Management

## Inputs

The data available under inputs is:

Item Checked	Result Unit
EMS Main relay status	relay on/off
Fuel pump relay status	on/off
Starter relay status	starter on/off
Starter switch status	switch on/off
Side stand status	up/down
Fall detection switch status	normal/over
Clutch switch status	release/grip
Neutral switch status	gear/neutral
Gear position status	numeric value or neutral
Vehicle speed	km/h
Malfunction indicator light status	MIL on/off
Cooling fan status	fan on/off
Calculated load	%
Purge valve duty cycle‡	%

‡ Applies to models fitted with a purge valve only. All other models will show **Not Applicable** in this field.

## Adaption Status

Because the fuel system is adaptive, the engine management system is able to automatically adjust to new working conditions, such as changes in altitude, component wear, air leaks etc. This screen displays information on the adaption status of the vehicle which will show if it has adapted or not.

Function Examined	Report Method
Closed Throttle Position Adapted	adapted/not adapted
Idle speed control adaption status	%
Oxygen sensor 1 adaption range (off idle)	%
Oxygen sensor 1 adaption range (idle)	%
Oxygen sensor 1 adaption status (off idle)	%
Oxygen sensor 1 adaption status (idle)	%

# Fuel System/Engine Management

---

## Function Tests

The system allows the diagnostic software to perform a series of function tests on various actuators in the engine management system. In some cases it is necessary to make a visual observation of a component and in others, if faults are present, DTCs will be logged.

The function tests available are:

Function Examined	Report Method
Instrument Panel	Observe instrument panel, refer to service manual
Idle Air Control Stepper Motor	Observe throttle position/Stored fault code*
Purge Valve†	Listen for valve operation/Stored fault code*
Fuel Pump - Priming	Listen for fuel pump operation/Stored fault code*
Fuel Pump - Continuous Operation	Fuel pressure test/Listen for fuel pump operation/Stored fault code*
Cooling Fan Control†	Observe the cooling fan/Stored fault code*

\* If a fault is detected.

## Instrument Panel Function Test

On the diagnostic software navigate to and select the 'FUNCTION TESTS' option.

Click the start button and observe the instruments for the following:

- tachometer needle moves to 7,500 rpm;
- the neutral indicator, fuel warning and malfunction indicator light (MIL) lights alternate on and off;
- coolant temperature increments up to maximum temperature;
- coolant warning light illuminates when coolant temperature gauge is at maximum;
- end of test. Instruments return to normal operation.

## Adjust Tune

Using the Triumph diagnostic software, it is possible to:

- reset the adaptations;
- balance the throttle bodies.

Further functions are provided to allow correct replacement and adjustment of the:

- throttle position sensor;
- idle speed control stepper motor.

These functions are needed as, after replacement of the parts concerned, adjustments have to be made to specific Voltage settings, with the throttles set in a specific position.

To reset adaptations, see page 10-116.

To replace and adjust the throttle position sensor, see page 10-112.

To replace and adjust the ISC stepper motor, see page 10-113.

To balance the throttles, see page 10-110.

## Freeze-frame Data

Freeze frame data is stored at the time a DTC is recorded (confirmed) by the ECM. If multiple DTCs are recorded, the freeze-frame data which is stored will relate to the first recorded DTC only.

By calling up freeze frame data associated with the first recorded DTC, the technician can check the engine condition at the time the fault occurred. The data available is:

Function Examined	Result Reported (Scale)
DTC	Diagnostic Trouble Code (DTC) number
Fuel system status 1	open or closed loop operation
Calculated load	%
Coolant temperature	°C
Short term fuel trim - bank 1	%
Intake manifold absolute pressure	mm/hg
Engine speed	RPM
Vehicle speed	km/h
Ignition advance	degrees
Intake air temperature	°C
Throttle position	%
Oxygen sensor 1 output Voltage	Volts
Oxygen sensor 1 short term fuel trim	%

# Fuel System/Engine Management

## Diagnostic Trouble Codes

Diagnostic trouble codes (DTCs) are logged in the ECM memory when there is a confirmed fault in the system.

The codes are reported to the Triumph diagnostic software as a four digit code.

As mentioned earlier, when the system detects a fault, it begins to count the number of times the fault occurs before illuminating the MIL and storing a fault code.

Similarly, if a fault clears, the ECM also records this fact and will turn off the MIL when sufficient no-fault warm-up cycles have taken place. Any fault codes will remain in the ECM memory until the required number of no-fault warm-up cycles have taken place. The number of warm-up cycles required to extinguish the MIL will always be less than the number required to remove a DTC from the ECM memory. DTCs can be removed at any time using the Triumph diagnostic software.

The system will log the diagnostic trouble codes listed below/over:

Diagnostic Trouble Code (DTC)	Fault Description	Number of no-fault cycles before turning off MIL	Number of no-fault cycles before DTC is erased	MIL illuminated when fault is logged
P0201	Injector 1 circuit malfunction	3	40	Yes
P0202	Injector 2 circuit malfunction	3	40	Yes
P0203	Injector 3 circuit malfunction	3	40	Yes
P1201	Injector 1 open circuit/short to ground	3	40	Yes
P1202	Injector 2 open circuit/short to ground	3	40	Yes
P1203	Injector 3 open circuit/short to ground	3	40	Yes
P0351	Ignition coil 1 circuit malfunction	3	40	Yes
P0352	Ignition coil 2 circuit malfunction	3	40	Yes
P0353	Ignition coil 3 circuit malfunction	3	40	Yes
P0335	Crankshaft sensor circuit malfunction	3	40	Yes
P0032	Oxygen sensor heater short circuit to battery	3	40	Yes
P0031	Oxygen sensor heater open circuit/short to ground	3	40	Yes
P0030	Oxygen sensor heater circuit malfunction	3	40	Yes
P0136	Oxygen sensor circuit malfunction	3	40	Yes
P0122	Throttle position sensor low input	3	40	Yes
P0123	Throttle position sensor high input	3	40	Yes
P0107	Manifold absolute pressure sensor low voltage	3	40	Yes
P0108	Manifold absolute pressure sensor high voltage	3	40	Yes
P1105	Manifold absolute pressure sensor pipe malfunction	3	40	Yes
P1107	Ambient air pressure sensor circuit low voltage	3	40	Yes
P1108	Ambient air pressure sensor circuit high voltage	3	40	Yes
P0112	Intake air temperature too high	3	40	Yes
P0113	Intake air temperature too low	3	40	Yes
P0117	Engine coolant temperature too high	3	40	Yes
P0118	Engine coolant temperature too low	3	40	Yes

## Fuel System/Engine Management

<b>Diagnostic Trouble Code (DTC)</b>	<b>Fault Description</b>	<b>Number of no-fault cycles before turning off MIL</b>	<b>Number of no-fault cycles before DTC is erased</b>	<b>MIL illuminated when fault is logged</b>
P0500	Vehicle speed sensor malfunction	3	40	Yes
P1552	Cooling fan short circuit/open circuit	3	40	Yes
P1553	Cooling fan short to battery voltage/over temperature	3	40	Yes
P1628	Fuel pump short circuit to ground or open circuit	3	40	Yes
P1231	Fuel pump relay short circuit to ground or open circuit	3	40	Yes
P1232	fuel pump relay short circuit to battery	3	40	Yes
P1629	Fuel pump short circuit to battery	3	40	Yes
P0444	Purge valve system short circuit to ground or open circuit	3	40	Yes
P0445	Purge valve system short circuit to battery	3	40	Yes
P0617	Starter relay short circuit to battery	3	40	Yes
P0616	Starter relay short circuit to ground or open circuit	3	40	Yes
P0505	Idle speed control system malfunction	3	40	Yes
P1631	Fall detection sensor circuit low voltage	3	40	Yes
P1632	Fall detection sensor circuit high voltage	3	40	Yes
P0560	System voltage - battery circuit malfunction	3	40	Yes
P1500	Vehicle speed output circuit malfunction*	0	40	No
P0654	Tachometer circuit malfunction*	0	40	No
P1115	Coolant temperature gauge circuit malfunction*	0	40	No
P0460	Fuel level sensor circuit malfunction*	3	40	Yes
P0705	Gear position sensor circuit malfunction*	0	40	No
P0630	EEPROM fault*	0	40	No
P1690	CAN communication fault	N/A	40	No

\*Supported by DTC P1690

## Fuel System/Engine Management

<b>Diagnostic Trouble Code (DTC)</b>	<b>Fault Description</b>	<b>Number of no-fault cycles before turning off MIL</b>	<b>Number of no-fault cycles before DTC is erased</b>	<b>MIL illuminated when fault is logged</b>
P1685	EMS main relay circuit malfunction	3	40	Yes
P1659	EMS ignition voltage input malfunction	3	40	Yes
P1698	Sensor supply (Vcc) circuit malfunction	3	40	Yes
P1602	Tunelock	Only if Tunelock is unlocked		Flashing
P1614	ECM or tune ID Incorrect	Only if Instrument ID Matching		Flashing
P1508	Immobiliser/TPMS control module ID incompatible	3	40	Flashing
P1520	ABS modulator ID incompatible	3	40	Flashing
P1521	Lost communication with the ABS modulator	3	40	Yes



## Electrical Connectors

Before beginning any diagnosis, the following connector related information should be noted:

### Note:

- **A major cause of hidden electrical faults can be traced to faulty electrical connectors. For example:**
- **Dirty/corroded terminals.**
- **Damp terminals.**
- **Broken or bent cable pins within multi-plugs.**

For example, the electronic control module (ECM) relies on the supply of accurate information to enable it to plan the correct fueling and ignition timing. One dirty terminal will cause an excessive voltage drop resulting in an incorrect signal to the ECM.

If, when carrying out fault diagnosis, a fault appears to clear by simply disconnecting and reconnecting an electrical plug, examine each disconnected plug for the following.

### Before Disconnection:

- **If testing with a voltmeter, the voltage across a connector should be virtually battery volts (unless a resistor is fitted in the circuit). If there is a noticeable change, suspect faulty/dirty connections.**

### When Disconnecting a Connector:

- **Check for a security device that must be released before the connector can be separated. E.G. barb, hook and eye etc.**

### When Inspecting a Connector:

- **Check that the individual pins have not been bent.**
- **Check for dampness/dirt/corrosion.**
- **Check cables for security.**
- **Check cable pin joints for damage.**

### When Connecting a Connector:

- **Ensure there is no dirt around the connector/seal.**
- **Push together squarely to ensure terminals are not bent or incorrectly located.**
- **Push the two halves together positively.**

## Disconnection of ECM connectors

### Note:

- **Two different coloured and shaped connectors are used in the ECM, which ensures correct connection is always made. The connectors on the ECM are coloured black and grey, and correspond with identical coloured connectors on the main harness.**

### ! Caution

When disconnecting a connector, never pull directly on the wires as this may result in cable and connector damage.

### ! Caution

Never disconnect the ECM when the ignition switch is in the 'ON' position as this may cause multiple fault codes to be logged in the ECM memory.

Always disconnect an ECM after disconnecting the battery negative (black) lead first.

1. Turn the ignition to the 'OFF' position and wait at least 1 minute for the ECM to complete its power down sequence.
2. Press down on the locking device and gently pull back on the connector to release it from the ECM.

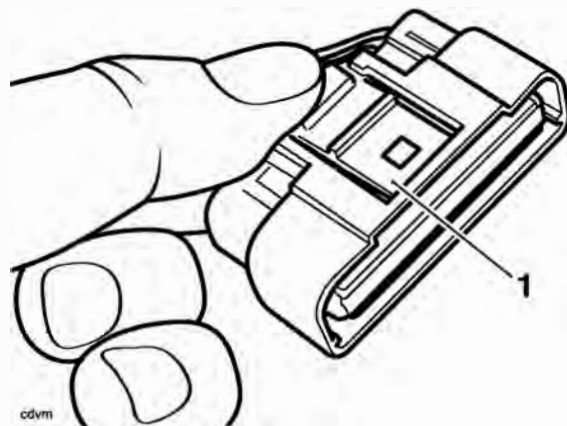

1. Locking device

### Note:

- **The ECM is located beneath the rider's seat, to the left of the battery.**

# Fuel System/Engine Management

## Reconnection of ECM connectors

### Note:

- **Two different coloured and shaped connectors are used in the ECM, which ensures correct connection is always made. The connectors on the ECM are coloured black and grey, and correspond with identical coloured connectors on the main harness.**



### Caution

Damage to the connector pins may result if an attempt to fit the connectors incorrectly is made.

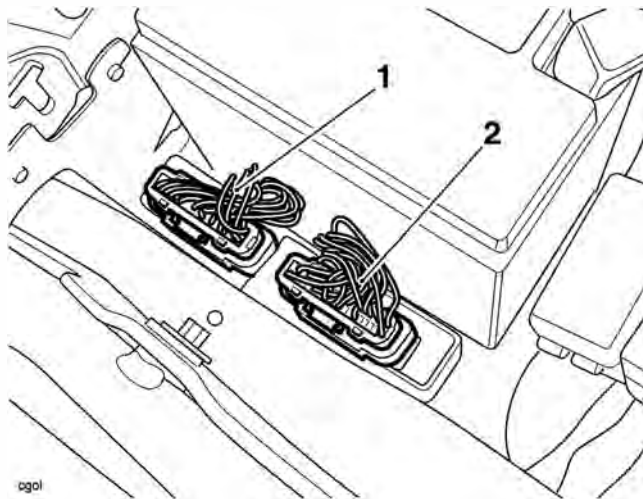

1. ECM grey connector  
2. ECM black connector

1. Fit the first connector into its socket and, whilst holding the connector in place, insert it fully into the ECM until the locking device retains it.
2. Repeat the above for the second connector.

## Further Diagnosis

The tables that follow will, if used correctly, help to pinpoint a fault in the system once a diagnostic trouble code has been stored.

## Crankshaft Sensor

Fault Code	Possible cause	Action
P0335	Crankshaft sensor system fault	View & note diagnostic software 'freeze frame' data if available. Ensure sensor is fitted correctly and connector is secure. Disconnect ECM and proceed to pinpoint test 1:

### Pinpoint Tests

Test	Result	Action
1 Check terminal and cable integrity: - ECM pin A01 - ECM pin A09	OK	Disconnect sensor and proceed to test 2
	Faulty	Rectify fault, proceed to test 6
2 Check cable for short circuit: - ECM pin A01 to earth - ECM pin A09 to earth	OK	Proceed to test 3
	Short circuit	Locate and rectify wiring fault, proceed to test 6
3 Check cable continuity: - ECM pin A09 to sensor pin 1 - ECM pin A01 to sensor pin 2	OK	Proceed to test 4
	Open circuit	Locate and rectify wiring fault, proceed to test 6
4 Check cable for short circuit: - ECM pin A01 to ECM pin A09	OK	Renew crankshaft sensor, proceed to test 6
	Short circuit	Locate and rectify wiring fault, proceed to test 6
5 Check crank toothed wheel: - Damage to teeth - magnetic debris contamination	OK	Proceed to test 6
	Faulty	Clean / renew toothed wheel, proceed to test 6
6 Reconnect harness, clear fault code and run engine to verify fault cleared	OK	Action complete - quit test
	Fault still present	Contact Triumph service

### Circuit Diagram

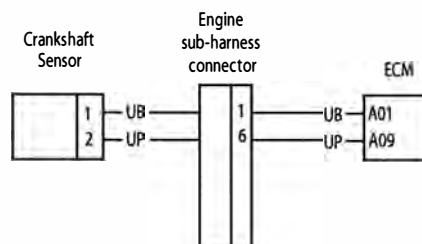

# Fuel System/Engine Management

## Idle Speed Control

Fault Code	Possible cause	Action
P0505	ISC stepper motor / wiring fault	View & note diagnostic software 'freeze frame' data if available. View & note diagnostic software 'sensor' data. Ensure sensor connector is secure. Disconnect ECM and proceed to pinpoint test 1:

## Pinpoint Tests

Test	Result	Action
1 Check cable and terminal integrity: - ECM pin A20 - ECM pin A21 - ECM pin A22 - ECM pin A23	OK	Proceed to test 2
	Faulty	Rectify fault, proceed to test 7
2 Check resistance value:  - ECM pin A20 to ECM pin A21 - ECM pin A22 to ECM pin A23	4Ω to 12Ω	Disconnect stepper motor and proceed to test 3
	Open circuit	Disconnect stepper motor and proceed to test 4
	Short circuit	Disconnect stepper motor and proceed to test 5
3 Check cable for short circuit: - ECM pin A20 to earth - ECM pin A21 to earth - ECM pin A22 to earth - ECM pin A23 to earth	OK	Proceed to test 7
	Short circuit	Locate and rectify wiring fault, proceed to test 7
4 Check cable continuity: - ECM pin A22 to stepper motor pin A - ECM pin A23 to stepper motor pin A1 - ECM pin A20 to stepper motor pin B - ECM pin A21 to stepper motor pin B1	OK	Proceed to test 6
	Open circuit	Locate and rectify wiring fault, proceed to test 7
5 Check cable for short circuit: - ECM pin A22 to ECM pin A23 - ECM pin A20 to ECM pin A21	OK	Proceed to test 6
	Short circuit	Locate and rectify wiring fault, proceed to test 7
6 Check stepper motor resistance: - Motor pin A to motor pin A1 - Motor pin B to motor pin B1	4Ω to 12Ω	Proceed to test 7
	Faulty	Renew stepper motor, proceed to test 7
7 Reconnect harness, clear fault code and run diagnostic software function test to visually verify operation of stepper motor	OK	Action complete - quit test
	Fault still present	Contact Triumph service

Circuit Diagram

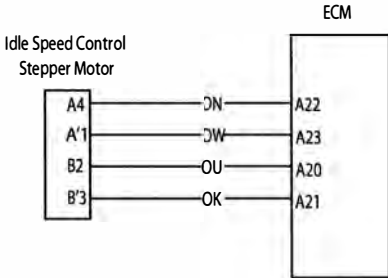

# Fuel System/Engine Management

## Fuel Injectors

Fault Code	Possible cause	Action
P0201/02/03	Injection system fault - injector 1/2/3 - Misfire indicates open circuit - Flooding indicates short circuit	View & note diagnostic software 'freeze frame' data if available. Ensure relevant injector connector is secure. Disconnect ECM and proceed to pinpoint test 1:

### Pinpoint Tests

Test	Result	Action
1 Check cable and terminal integrity: - ECM pin A15 - ECM pin A14 - ECM pin A13	OK	Proceed to test 2
	Faulty	Rectify fault, proceed to test 7
2 Check resistance value: - ECM pin A06 to ECM pin A15 (injector 1) - ECM pin A06 to ECM pin A14 (injector 2) - ECM pin A06 to ECM pin A13 (injector 3)	11.0Ω to 12.5Ω	Proceed to test 3
	Open circuit	Disconnect relevant injector and proceed to test 4
	Short circuit	Disconnect relevant injector and proceed to test 5
3 Check cable for short circuit to ground: - ECM pin A15 to earth - ECM pin A14 to earth - ECM pin A13 to earth	OK	Proceed to test 7
	Short circuit	Locate and rectify wiring fault, proceed to test 7
4 Check cable continuity: - ECM pin A06 to relevant injector pin 2 - ECM pin A15 to injector 1 pin 1 - ECM pin A14 to injector 2 pin 1 - ECM pin A13 to injector 3 pin 1	OK	Proceed to test 6
	Open circuit	Locate and rectify wiring fault, proceed to test 7
5 Check cable for short circuit to supply box: - ECM pin A06 to ECM pin A15 (inj 1) - ECM pin A06 to ECM pin A14 (inj 2) - ECM pin A06 to ECM pin A13 (inj 3)	OK	Proceed to test 6
	Short circuit	Locate and rectify wiring fault, proceed to test 7
6 Check relevant injector resistance: - Injector pin 1 to injector pin 2	11.0Ω to 12.5Ω	Proceed to test 7
	Faulty	Renew relevant injector, proceed to test 7
7 Reconnect harness, clear fault code and run engine to verify fault cleared	OK	Action complete - quit test
	Fault still present	Contact Triumph service

## Circuit Diagram

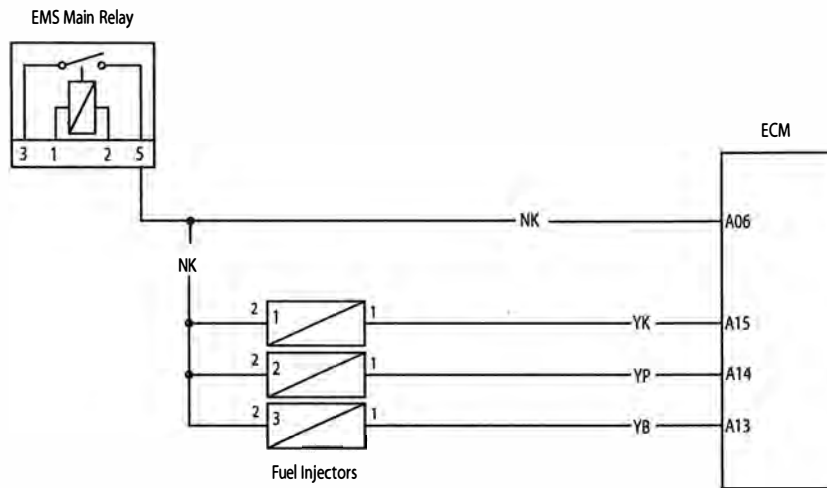

# Fuel System/Engine Management

## Throttle Position Sensor

Fault Code	Possible cause	Action
P0122 P0123	Throttle position sensor low input voltage (short to ground or open circuit) Throttle position sensor high input voltage (short circuit to sensor supply)	View & note diagnostic software 'freeze frame' data if available. View & note diagnostic software 'sensor' data. Ensure sensor connector is secure. Disconnect ECM and proceed to pinpoint test 1:

### Pinpoint Tests

Test	Result	Action
1 Check cable and terminal integrity: - ECM pin B01 - ECM pin B20 - ECM pin A10	OK	Disconnect sensor and proceed to test 2
	Faulty	Rectify fault, proceed to test 5
2 Check cable for short circuit: - ECM pin A10 to ground	OK	Proceed to test 3
	Short circuit	Locate and rectify wiring fault, proceed to test 5
3 Check cable continuity: - ECM pin A10 to sensor pin 1 - ECM pin B20 to sensor pin 2 - ECM pin B01 to sensor pin 3	OK	Proceed to test 4
	Open circuit	Locate and rectify wiring fault, proceed to test 5
4 Check cable for short circuit: - ECM pin A10 to ECM pin B01 - ECM pin A10 to ECM pin B20	OK	Renew throttle position sensor, proceed to test 5
	Short circuit	Locate and rectify wiring fault, proceed to test 5
5 Reconnect harness, clear fault code and run engine to verify fault cleared	OK	Action complete - quit test
	Fault still present	Contact Triumph service



## Circuit Diagram

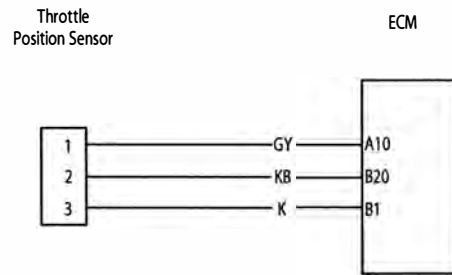

# Fuel System/Engine Management

## Purge Valve

Fault Code	Possible cause	Action
P0444	Open circuit or short circuit to earth	View & note diagnostic software 'sensor' data. Ensure purge valve connector is secure. Disconnect ECM and proceed to pinpoint test 1:
P0445	Short circuit to battery+	Disconnect purge valve and proceed to pinpoint test 5:

## Pinpoint Tests

Test	Result	Action
1 Check cable and terminal integrity: - ECM pin B09	OK	Proceed to test 2
	Faulty	Rectify fault, proceed to test 7
2 Check resistance value: - ECM pin A06 to ECM pin B09	24Ω to 28Ω	Disconnect purge valve and proceed to test 3
	Open circuit	Proceed to test 4
	Short circuit	Disconnect purge valve and proceed to test 5
3 Check cable for short circuit: - ECM pin B09 to earth	OK	Disconnect purge valve and proceed to test 7
	Short circuit	Locate and rectify wiring fault, proceed to test 7
4 Check cable continuity: - ECM pin B09 to valve pin 2 - ECM pin A06 to valve pin 1	OK	Proceed to test 6
	Open circuit	Locate and rectify wiring fault, proceed to test 7
5 Check cable for short circuit: - ECM pin A06 to ECM pin B09	OK	Proceed to test 6
	Short circuit	Locate and rectify wiring fault, proceed to test 7
6 Check purge valve resistance: - Valve pin 1 to valve pin 2	24Ω to 28Ω	Proceed to test 7
	Faulty	Renew purge valve, proceed to test 7
7 Reconnect harness, clear fault code and run diagnostic software function test to visually verify operation of purge valve	OK	Action complete - quit test
	Fault still present	Contact Triumph service

## Circuit Diagram

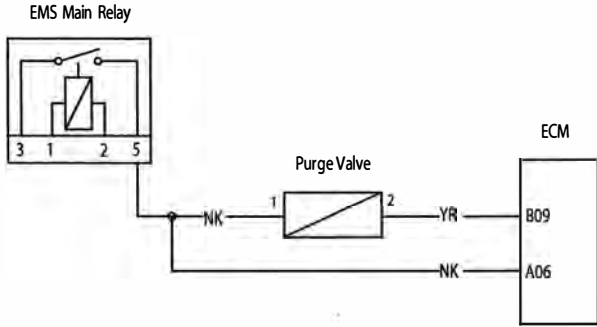

# Fuel System/Engine Management

## Ignition Coils

Fault Code	Possible cause	Action
P0351/52/53	Ignition system fault - ignition coil 1/2/3	View & note diagnostic software 'freeze frame' data if available. Ensure relevant ignition coil connector is secure. Disconnect ECM and proceed to pinpoint test 1:

## Pinpoint Tests

Test	Result	Action
1 Check cable and terminal integrity: - ECM pin B17 - ECM pin A18 - ECM pin B18	OK	Proceed to test 2
	Faulty	Rectify fault, proceed to test 7
2 Check resistance value: ECM pin A06 to - ECM pin (ignition coil 1) B17 - ECM pin (ignition coil 2) A18 - ECM pin (ignition coil 3) B18	0.8Ω to 1.2Ω	Proceed to test 3
	Open circuit	Disconnect relevant ignition coil and proceed to test 4
	Short circuit	Disconnect relevant ignition coil and proceed to test 5
3 Check cable for short circuit: - ECM pin B17 to earth - ECM pin A18 to earth - ECM pin B18 to earth	OK	Proceed to test 7
	Short circuit	Locate and rectify wiring fault, proceed to test 7
4 Check cable continuity: EMS main relay pin 5 to any ignition coil pin 2 - ECM pin B17 to ignition coil 1 pin 1 - ECM pin A18 to ignition coil 2 pin 1 - ECM pin B18 to ignition coil 3 pin 1	OK	Proceed to test 6
	Open circuit	Locate and rectify wiring fault, proceed to test 7
5 Check cable for short circuit: ECM pin A06 to - ECM pin (ignition coil 1) B17 - ECM pin (ignition coil 2) A18 - ECM pin (ignition coil 3) B18	OK	Proceed to test 6
	Short circuit	Locate and rectify wiring fault, proceed to test 7
6 Check relevant ignition coil resistance: - Ignition coil pin 1 to ignition coil pin 2	0.8Ω to 1.2Ω	Proceed to test 7
	Faulty	Renew relevant ignition coil, proceed to test 7
7 Reconnect harness, clear fault code and run engine to verify fault cleared	OK	Action complete - quit test
	Fault still present	Contact Triumph service

Circuit Diagram

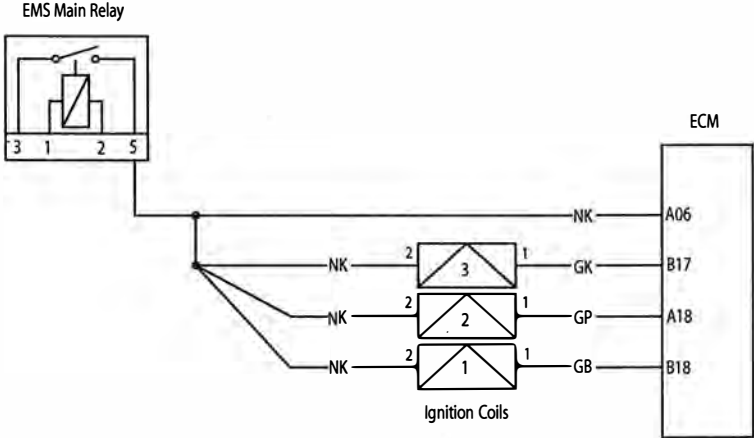

# Fuel System/Engine Management

## Coolant Temperature Sensor

Fault Code	Possible cause	Action
P0118	Open circuit, or short circuit to battery+	View & note diagnostic software 'freeze frame' data if available. View & note diagnostic software 'sensor' data. Ensure sensor connector is secure. Disconnect ECM and proceed to pinpoint test 1:
P0117	Short circuit to ground	Disconnect sensor and proceed to test 6:

### Pinpoint Tests

Test	Result	Action
1 Check cable and terminal integrity: - ECM pin A29 - ECM pin B20	OK	Proceed to test 2
	Faulty	Rectify fault, proceed to test 7
2 Check resistance value: - ECM pin A29 to ECM pin B20 (Temperature dependent - see below)	OK	Disconnect temp sensor and proceed to test 6
	Open circuit	Disconnect sensor and proceed to test 3
	Short circuit	Disconnect temp sensor and proceed to test 4
3 Check cable continuity: - ECM pin A29 to sensor pin 1 - ECM pin B20 to sensor pin 2	OK	Proceed to test 5
	Open circuit	Locate and rectify wiring fault, proceed to test 7
4 Check cable for short circuit: - ECM pin A29 to ECM pin B20	OK	Proceed to test 5
	Short circuit	Locate and rectify wiring fault, proceed to test 7
5 Check sensor resistance: - Sensor pin 1 to sensor pin 2 (Temperature dependent - see below)	OK	Proceed to test 7
	Faulty	Renew temp sensor, proceed to test 7
6 Check cable for short circuit: - ECM pin A29 to ground	OK	Proceed to test 7
	Short circuit	Locate and rectify wiring fault, proceed to test 7
7 Reconnect harness, clear fault code and run engine to verify fault cleared	OK	Action complete - quit test
	Fault still present	Contact Triumph service

## Circuit Diagram

Resistance data under typical conditions:

Warm engine: 200 to 400 $\Omega$

Cold engine:

20°C ambient 2.35 to 2.65K $\Omega$

-10°C ambient 8.50 to 10.25K $\Omega$

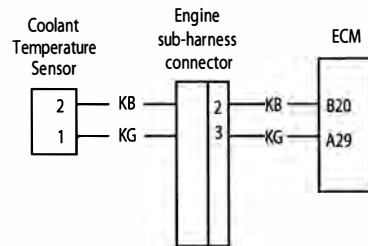

# Fuel System/Engine Management

## Intake Air Temperature Sensor

Fault Code	Possible cause	Action
P0113	Open circuit, or short circuit to battery+	View & note diagnostic software 'freeze frame' data if available. View & note diagnostic software 'sensor' data. Ensure sensor connector is secure. Disconnect ECM and proceed to pinpoint test 1:
P0112	Short circuit to ground	Disconnect sensor and proceed to pinpoint test 6:

### Pinpoint Tests

Test	Result	Action
1 Check cable and terminal integrity: - ECM pin A11 - ECM pin B20	OK	Proceed to test 2
	Faulty	Rectify fault, proceed to test 7
2 Check resistance value: - ECM pin A11 to ECM pin B20 (Temperature dependent - see below)	OK	Disconnect temp sensor and proceed to test 6
	Open circuit	Disconnect temp sensor and proceed to test 3
	Short circuit	Disconnect temp sensor and proceed to test 4
3 Check cable continuity: - ECM pin A11 to sensor pin 1 - ECM pin B20 to sensor pin 2	OK	Proceed to test 5
	Open circuit	Locate and rectify wiring fault, proceed to test 7
4 Check cable for short circuit: - ECM pin A11 to ECM pin B20	OK	Proceed to test 5
	Short circuit	Locate and rectify wiring fault, proceed to test 7
5 Check sensor resistance: - Sensor pin 1 to sensor pin 2 (Temperature dependent - see below)	OK	Proceed to test 7
	Faulty	Renew temp sensor, proceed to test 7
6 Check cable for short circuit: - ECM pin A11 to ground	OK	Proceed to test 7
	Short circuit	Locate and rectify wiring fault, proceed to test 7
7 Reconnect harness, clear fault code and run engine to verify fault cleared	OK	Action complete - quit test
	Fault still present	Contact Triumph service



## Circuit Diagram

If engine is warm, remove sensor and allow time to cool to ambient prior to test.

Resistance data:

Ambient temp	Resistance value
80°C	200 to 400Ω
20°C	2.35 to 2.65KΩ
-10°C	8.50 to 10.25KΩ

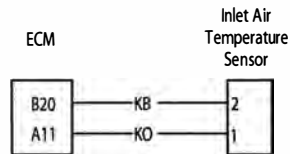

# Fuel System/Engine Management

## System Voltage

Fault Code	Possible cause	Action
P0560	Bike voltage system fault	View & note diagnostic software 'sensor' data. Ensure voltage across battery is acceptable, note voltage. Disconnect ECM and proceed to pinpoint test 1:

## Pinpoint Tests

Test	Result	Action
1 Check cable and terminal integrity: - ECM pin A06	OK	Proceed to test 2
	Faulty	Rectify fault, proceed to test 3
2 With Ignition 'ON', check voltage at: - ECM pin A06	Same as 'across battery' voltage	Proceed to test 3
	Less than 'across battery' voltage	Locate and rectify wiring fault, proceed to test 3
3 Reconnect harness, clear fault code and run engine to verify fault cleared	OK	Action complete - quit test
	Fault still present	Contact Triumph service

## Circuit Diagram

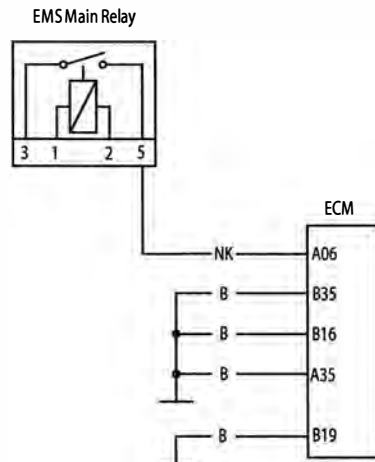

## Cooling Fan Relay

Fault Code	Possible cause	Action
P1552	Fan relay open circuit, or short circuit to ground	View & note diagnostic software 'sensor' data. Ensure fan relay connector is secure. Disconnect ECM and proceed to pinpoint test 1:
P1553	Short circuit to battery+	Disconnect fan relay and proceed to pinpoint test 4:

### Pinpoint Tests

Test	Result	Action
1 Check cable and terminal integrity: - ECM pin B30	OK	Disconnect fan relay and proceed to test 2
	Faulty	Rectify fault, proceed to test 5
2 Check cable for short circuit: - ECM pin B30 to ground	OK	Proceed to test 3
	Short circuit	Locate and rectify wiring fault, proceed to test 5
3 Check cable continuity: - Fan relay pin 2 to ECM pin B30 - Fan relay pin 1 to EMS main relay pin 5	OK	Proceed to test 4
	Open circuit	Locate and rectify wiring fault, proceed to test 5
4 Check cable for short circuit: - ECM pin B30 to ECM pin A06	OK	Proceed to test 5
	Short circuit	Locate and rectify wiring fault, proceed to test 5
5 Reconnect harness, clear fault code and run diagnostic software function test to visually verify operation of cooling fan	OK	Action complete - quit test
	Fault still present	Contact Triumph service

### Circuit Diagram

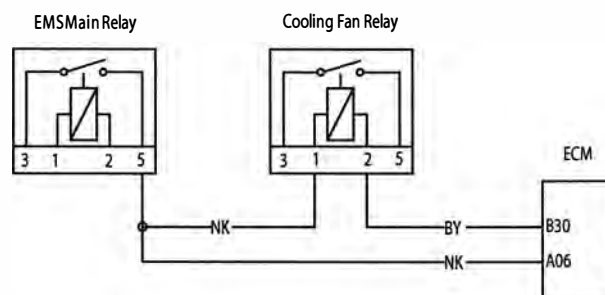

# Fuel System/Engine Management

## Oxygen Sensor

Fault Code	Possible cause	Action
P0130	Oxygen sensor circuit fault	View & note 'freeze frame' data if available. View & note 'sensor' data. Ensure sensor connector is secure. Disconnect ECM and proceed to pinpoint test 1:

### Pinpoint Tests

Test	Result	Action
1 Check cable and terminal integrity:  - ECM pin A26 - ECM pin B20	OK	Disconnect oxygen sensor and proceed to test 2
	Faulty	Rectify fault, proceed to test 4
2 Check cable for short circuit:  - ECM pin A26 to ECM pin B20 - ECM pin A26 to ECM pin A06	OK	Proceed to test 3
	Short circuit	Locate and rectify wiring fault, proceed to test 4
3 Check cable continuity:  - ECM pin A26 to sensor pin 2 - ECM pin B20 to sensor pin 1	OK	Proceed to test 4
	Open circuit	Locate and rectify wiring fault, proceed to test 4
4 Reconnect harness, clear fault code and run engine. Check adaptation status	OK	Action complete - quit test
	Fault still present	Contact Triumph service

### Circuit Diagram

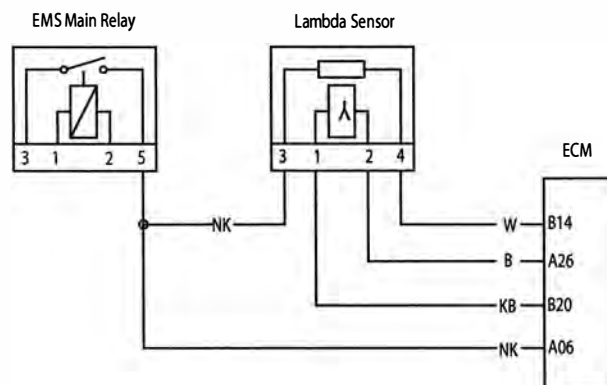

## Oxygen Sensor Heater

Fault Code	Possible cause	Action
P0031	Oxygen sensor heater circuit short circuit to ground or open circuit	View & note 'freeze frame' data if available. View & note 'sensor' data. Ensure sensor connector is secure. Disconnect ECM and proceed to pinpoint test 1:
P0032	Oxygen sensor heater circuit, short circuit to battery	Disconnect oxygen sensor and proceed to pinpoint test 4:

### Pinpoint Tests

Test	Result	Action
1 Check cable and terminal integrity: - ECM pin B14	OK	Disconnect oxygen sensor and proceed to test 2
	Faulty	Rectify fault, proceed to test 5
2 Check cable for short circuit: - ECM pin B14 to ground	OK	Proceed to test 3
	Short circuit	Locate and rectify wiring fault, proceed to test 5
3 Check cable continuity: - ECM pin B14 to sensor pin 4 - ECM pin A06 to sensor pin 3	OK	Proceed to test 5
	Open circuit	Locate and rectify wiring fault, proceed to test 5
4 Check cable for short circuit: - ECM pin B14 to ECM pin A06	OK	Renew oxygen sensor and proceed to test 5
	Short circuit	Locate and rectify wiring fault, proceed to test 5
5 Reconnect harness, clear fault code and run engine. Check adaption status	OK	Action complete, quit test
	Fault still present	Contact Triumph service

### Circuit Diagram

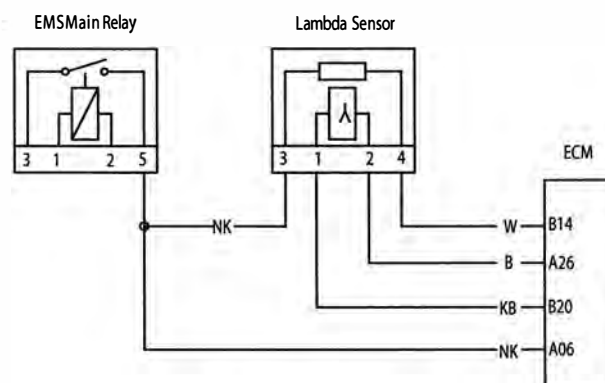

## Fuel System/Engine Management

---

### EEPROM Error

Fault Code	Possible cause	Action
P0603	EEPROM error	View & note 'freeze frame' data if available. No tests available - contact Triumph service.

## Fall Detection Switch

Fault Code	Possible cause	Action
P1631 P1632	Fall detection switch low input voltage Fall detection switch high input voltage or open circuit	View & note 'freeze frame' data if available. View & note 'sensor' data Ensure switch connector is secure. Disconnect ECM and proceed to pinpoint test 1:

## Pinpoint Tests

Test	Result	Action
1 Check cable and terminal integrity: - ECM pin B21	OK	Disconnect sensor and proceed to test 2
	Faulty	Rectify fault, proceed to test 6
2 Check cable for short circuit: - ECM pin B21 to ground	OK	Proceed to test 3
	Short circuit	Locate and rectify wiring fault, proceed to test 6
3 Check cable continuity: - ECM pin B01 to sensor pin 4 - ECM pin B21 to sensor pin 5 - ECM pin B20 to sensor pin 6	OK	Proceed to test 4
	Open circuit	Locate and rectify wiring fault, proceed to test 6
4 Check cable for short circuit: - ECM pin B21 to ECM pin B1 - ECM pin B21 to ECM pin B20	OK	Connect ECM and proceed to test 5
	Short circuit	Locate and rectify wiring fault, proceed to test 6
5 Check voltage (with ignition 'ON') between: - Sensor pin 4 and sensor pin 6	5V	Renew fall detection switch and proceed to test 6
	Less than 4.8V	Locate and rectify wiring fault, proceed to test 6
6 Reconnect harness, clear fault code	OK	Action complete, quit test
	Fault still present	Contact Triumph service

## Circuit Diagram

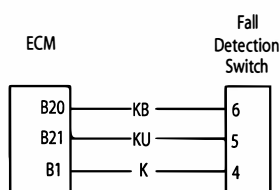

# Fuel System/Engine Management

## Vehicle Speed Sensor

Fault Code	Possible cause	Action
P0500	Vehicle speed sensor circuit fault - Tiger 800 and Tiger 800XC without ABS	View & note 'freeze frame' data if available. View & note 'sensor' data. Ensure sensor connector is secure. Disconnect ECM and proceed to pinpoint test 1:
	Rear wheel speed sensor - Tiger 800 and Tiger 800XC with ABS	Refer to C1613 (see page 14-60)

### Pinpoint Tests

Test	Result	Action
1 Check cable and terminal integrity: - ECM pin A34 - Instrument pin 9	OK	Disconnect sensor and proceed to test 2
	Faulty	Rectify fault, proceed to test 4
2 Check cable for short circuit: - ECM pin A34 to ground - ECM pin A34 to Instruments pin 9	OK	Proceed to test 3
	Faulty	Locate and rectify wiring fault, proceed to test 4
3 Check cable for continuity:  - ECM pin A34 to sensor pin 3 - Sensor pin 2 to ground - Instruments pin 9 to sensor pin 1	OK	Renew vehicle speed sensor and proceed to test 4
	Open circuit	Locate and rectify wiring fault, proceed to test 4
4 Reconnect harness, clear fault code and run engine	OK	Action complete, quit test
	Fault still present	Contact Triumph service

### Circuit Diagram

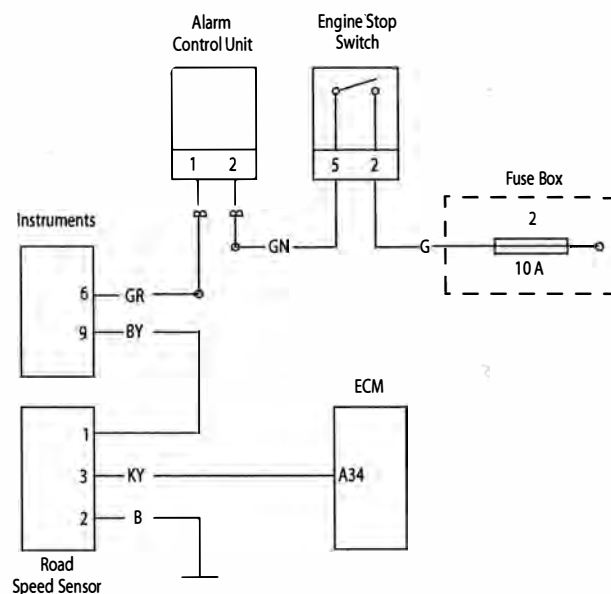



## CAN Communication

Fault Code	Possible cause	Action
P1690	Fault in CAN communication between ECM and other CAN nodes (Immobiliser unit, instruments and ABS module)	View & note 'freeze frame' data if available. Ensure ignition switch is in 'OFF' position. Proceed to pinpoint test 1.

### Pinpoint Test

Test	Result	Action
1 Check cable and terminal integrity: - ECM pin B28 - ECM pin B27 - Immobiliser pin 1 - Immobiliser pin 6 - Instrument pin 4 - Instrument pin 5 - ABS unit pin 1 - Diagnostic connector pin 6 - Diagnostic connector pin 14	OK	Disconnect the ECM and proceed to test 2
	Faulty	Rectify fault, proceed to test 4
2 Check cable for short circuit: - ECM pin B28 to ground - ECM pin B27 to ground	OK	Proceed to test 3
	Faulty	Locate and rectify wiring fault, proceed to test 4
3 Check cable resistance: - ECM pin B28 to ECM pin B27	More than 50Ω	Contact Triumph service
	Faulty (short circuit or less than 50Ω)	Locate and rectify wiring fault, proceed to test 4
5 Reconnect harness, clear fault code and run engine	OK	Action complete, quit test
	Fault still present	Contact Triumph service

### Circuit Diagram

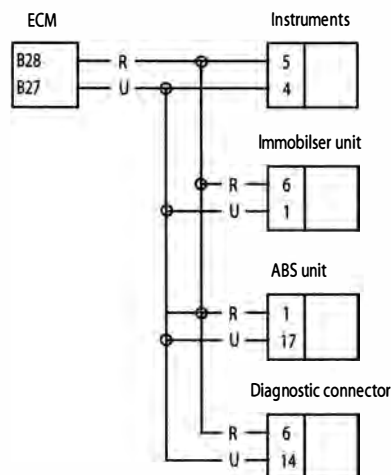

# Fuel System/Engine Management

## Instrument Communication (CAN)

Fault Code	Possible cause	Action
P1690	Fault in CAN communication between ECM and instrument pack.	View & note 'freeze frame' data if available. View & note 'sensor' data. Ensure instrument connector is secure. Disconnect ECM and proceed to pinpoint test 1:

### Pinpoint Tests

Test	Result	Action
1 Check cable and terminal integrity: - ECM pin B27 - ECM pin B28 - Instrument pin 4 - Instrument pin 5	OK	Disconnect instruments and proceed to test 2
	Faulty	Rectify fault, proceed to test 4
2 Check cable for short circuit: - ECM pin B27 to B28 - ECM pin B27 to ground - ECM pin B28 to ground	OK	Proceed to test 3
	Faulty	Locate and rectify wiring fault, proceed to test 4
3 Check cable continuity: - ECM pin B28 to Instrument pin 4 - ECM pin B27 to Instrument pin 5	OK	Contact Triumph service
	Open circuit	Locate and rectify wiring fault, proceed to test 4
4 Reconnect harness, clear fault code and run engine	OK	Action complete, quit test
	Fault still present	Contact Triumph service

### Circuit Diagram

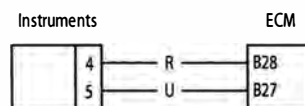

## Fuel Level Sensor

Fault Code	Possible cause	Action
P0460	Fuel level sensor circuit fault	View & note 'freeze frame' data if available. View & note 'sensor' data. Ensure sensor connector is secure. Disconnect ECM and proceed to pinpoint test 1:

### Pinpoint Tests

Test	Result	Action
1 Check cable and terminal integrity: - ECM pin B04	OK	Disconnect sensor and proceed to test 2
	Faulty	Rectify fault, proceed to test 5
2 Check cable for short circuit: - ECM pin B04 to ground	OK	Proceed to test 3
	Short circuit	Locate and rectify wiring fault, proceed to test 5
3 Check cable continuity: - ECM pin B04 to sensor pin 1 - Sensor pin 2 to ground	OK	Proceed to test 4
	Open circuit	Locate and rectify wiring fault, proceed to test 5
4 Check cable for short circuit: - Sensor pin 1 to sensor pin 2	OK	Renew fuel level sensor and proceed to test 5
	Short circuit	Locate and rectify wiring fault, proceed to test 5
5 Reconnect harness, clear fault code	OK	Action complete, quit test
	Fault still present	Contact Triumph service

### Circuit Diagram

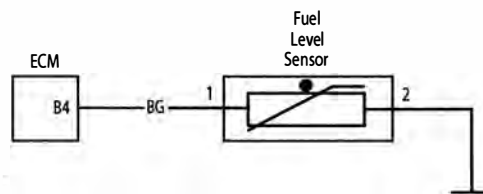

# Fuel System/Engine Management

## Ambient (Barometric) Pressure Sensor

Fault Code	Possible cause	Action
P1107	Ambient pressure sensor circuit short circuit to ground	View & note 'freeze frame' data if available. View & note 'sensor' data. Ensure sensor connector is secure. Disconnect ECM and proceed to pinpoint test 1:
P1108	Ambient pressure sensor circuit, short circuit to supply or open circuit	Disconnect ambient pressure sensor and proceed to pinpoint test 4:

### Pinpoint Tests

Test	Result	Action
1 Check cable and terminal integrity:  - ECM pin A27 - ECM pin B20 - ECM pin B01	OK	Disconnect ambient pressure sensor and proceed to test 2
	Faulty	Rectify fault, proceed to test 5
2 Check cable for short circuit:  - ECM pin A27 to ECM B20 - ECM pin A27 to ground	OK	Proceed to test 3
	Short circuit	Locate and rectify wiring fault, proceed to test 5
3 Check cable for continuity:  - ECM pin A27 to sensor pin 1 - ECM pin B20 to sensor pin 2 - ECM pin B01 to sensor pin 3	OK	Renew ambient pressure sensor and proceed to test 5
	Open circuit	Locate and rectify wiring fault, proceed to test 5
4 Check cable for short circuit: - ECM pin A27 to ECM pin B01	OK	Renew ambient pressure sensor and proceed to test 5
	Short circuit	Locate and rectify wiring fault, proceed to test 5
5 Reconnect harness, clear fault code and run engine	OK	Action complete, quit test
	Fault still present	Contact Triumph service

### Circuit Diagram

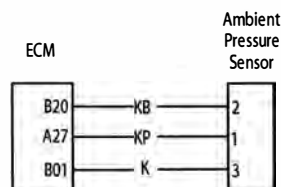

## Manifold Absolute Pressure (Map) Sensor

Fault Code	Possible cause	Action
P0107	MAP sensor circuit short circuit to ground	View & note 'freeze frame' data if available. View & note 'sensor' data. Ensure sensor connector is secure. Disconnect ECM and proceed to pinpoint test 1:
P0108	MAP sensor circuit, short circuit to supply or open circuit	Disconnect MAP sensor and proceed to test 4:
P1105	MAP sensor pipe fault	Check connection/condition of pipe from MAP sensor to throttle body.

### Pinpoint Tests

Test	Result	Action
1 Check cable and terminal integrity: - ECM pin A28 - ECM pin B20 - ECM pin B01	OK	Disconnect MAP sensor and proceed to test 2
	Faulty	Rectify fault, proceed to test 5
2 Check cable for short circuit: - ECM pin A28 to ECM B20 - ECM pin A28 to ground	OK	Proceed to test 3
	Short circuit	Locate and rectify wiring fault, proceed to test 5
3 Check cable for continuity: - ECM pin A28 to sensor pin 1 - ECM pin B20 to sensor pin 2 - ECM pin B01 to sensor pin 3	OK	Renew MAP sensor and proceed to test 5
	Open circuit	Locate and rectify wiring fault, proceed to test 5
4 Check cable for short circuit: - ECM pin A28 to ECM pin B01	OK	Renew MAP sensor and proceed to test 5
	Short circuit	Locate and rectify wiring fault, proceed to test 5
5 Reconnect harness, clear fault code and run engine	OK	Action complete, quit test
	Fault still present	Contact Triumph service

### Circuit Diagram

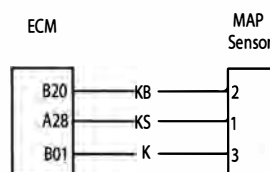

# Fuel System/Engine Management

## Gear Position Sensor

Fault Code	Possible cause	Action
P0705	Gear position sensor circuit fault	View & note 'freeze frame' data if available. View & note 'sensor' data. Ensure sensor connector is secure. Disconnect ECM and proceed to pinpoint test 1:

### Pinpoint Tests

Test	Result	Action
1 Check cable and terminal integrity: - ECM pin B24	OK	Disconnect sensor and proceed to test 2
	Faulty	Rectify fault, proceed to test 5
2 Check cable for short circuit: - ECM pin B24 to ground	OK	Proceed to test 3
	Short circuit	Locate and rectify wiring fault, proceed to test 5
3 Check cable for continuity: - ECM pin B24 to sensor pin 1 - ECM pin B20 to sensor pin 2 - ECM pin A31 to sensor pin 3	OK	Proceed to test 4
	Open circuit	Locate and rectify wiring fault, proceed to test 5
4 Check cable for short circuit: - Sensor pin 1 to sensor pin 2 - Sensor pin 1 to sensor pin 3	OK	Renew gear position sensor and contact pin and proceed to test 5
	Short circuit	Locate and rectify wiring fault, proceed to test 5
5 Reconnect harness, clear fault code	OK	Action complete, quit test
	Fault still present	Contact Triumph service

## Circuit Diagram

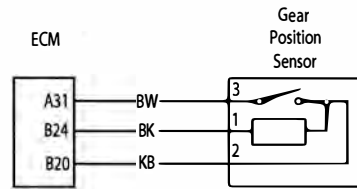

# Fuel System/Engine Management

## Fuel Pump

Fault Code	Possible cause	Action
P1231	Fuel pump relay short circuit to ground or open circuit	Check if pump runs briefly when ignition is switched on. Ensure fuel pump relay connector is secure. Disconnect ECM and proceed to pinpoint test 1:
P1232	Fuel pump relay short circuit to battery positive	Disconnect fuel pump relay and proceed to pinpoint test 4:

## Pinpoint Tests

Test	Result	Action
1 Check cable and terminal integrity: - ECM pin B29	OK	Disconnect fuel pump relay and proceed to test 2
	Faulty	Rectify fault, proceed to test 5
2 Check cable for short circuit to ground: - ECM pin B29 to earth	OK	Proceed to test 3
	Short circuit	Locate and rectify wiring fault, proceed to test 5
3 Check cable continuity: - ECM pin B29 to fuel pump relay pin 2 - Fuel pump relay pin 1 to ECM pin A19	OK	Proceed to test 4
	Open circuit	Locate and rectify wiring fault, proceed to test 5
4 Check cable for short circuit: - ECM pin B29 to Alarm pin 1 or 3	OK	Proceed to test 5
	Short circuit	Locate and rectify wiring fault, proceed to test 5
5 Reconnect harness, clear fault code and run diagnostic software function test to verify operation of fuel pump	OK	Action complete - quit test
	Fault still present	Contact Triumph service



## Circuit Diagram

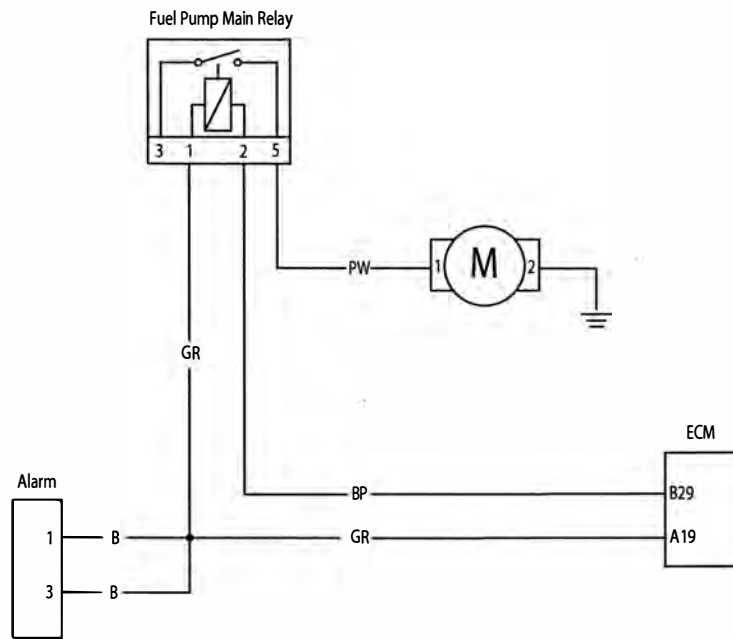

# Fuel System/Engine Management

## EMS Main Relay Circuit

Fault Code	Possible cause	Action
P1685	EMS main relay circuit fault	Note that the starter motor cannot be powered if a main relay fault exists. Ensure the EMS main relay connector is secure. Proceed to pinpoint test 1:

### Pinpoint Tests

Test	Result	Action
1 Ensure ignition has been switched off for greater than one minute. Identify EMS Main Relay on the harness.  Check that relay operates when the ignition is switched ON.	OK	Proceed to test 2
	Faulty	Disconnect ECM and proceed to test 4
2 Check fuse box Fuse 6 integrity	OK	Disconnect ECM and proceed to test 4
	Faulty	Disconnect ECM and proceed to test 3
3 Check cable for short circuit: - ECM pin A06 to ground - EMS Main relay pin 3 to ground	OK	Replace Fuse 6 and proceed to test 4
	Short circuit	Locate and rectify wiring fault, replace Fuse 6 and proceed to test 7
4 Check cable and terminal integrity: - ECM pin A06 - ECM pin B15 - EMS Main Relay pin 1 - EMS Main Relay pin 2 - EMS Main Relay pin 3 - EMS Main Relay pin 5	OK	Disconnect Main Relay and proceed to test 5
	Faulty	Rectify fault, proceed to test 7
5 Check cable for short circuit: - ECM pin B15 to ground	OK	Proceed to test 6
	Short circuit	Locate and rectify wiring fault, proceed to test 7
6 Check cable continuity:  - ECM pin A06 to EMS Relay pin 5 - ECM pin B15 to Relay pin 1 - EMS Main Relay pin 2 to ground - EMS Main Relay pin 3 to Fuse box Fuse 6	OK	Replace EMS Main Relay and proceed to test 7
	Open circuit	Locate and rectify wiring fault, proceed to test 7
7 Reconnect harness, clear fault code. Switch ignition off for longer than one minute. Switch ignition on and check that the EMS main relay operates. Start engine as final check	OK	Action complete - quit test
	Fault still present	Contact Triumph service

## Circuit Diagram

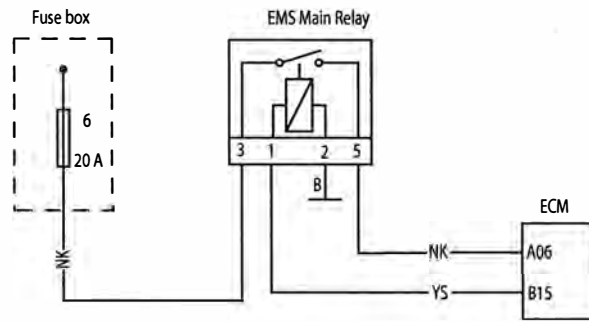

# Fuel System/Engine Management

## EMS Ignition Voltage Input Circuit

Fault Code	Possible cause	Action
P1659	EMS ignition voltage input circuit fault	Disconnect ECM and proceed to pinpoint test 1:

### Pinpoint Tests

Test	Result	Action
1 Check Fuse box Fuse 2 integrity	OK	Proceed to test 3
	Faulty	Proceed to test 2
2 Check cable for short circuit: - ECM pin A19 to ground	OK	Replace Fuse 2 and proceed to test 3
	Short circuit	Locate and rectify wiring fault, replace Fuse 2 and proceed to test 5
3 Check cable and terminal integrity: - ECM pin A19 - Alarm Connector pin 1 - Alarm Connector pin 2 - Right hand switchcube pin 2 - Right hand switchcube pin 5	OK	Proceed to test 4
	Faulty	Rectify fault, proceed to test 5
4 Check cable continuity: - ECM pin A19 to fuse box Fuse 2, note that the engine stop switch must be in the 'RUN' position and any Alarm fitted must be disarmed	OK	Proceed to test 5
	Open circuit	Locate and rectify wiring, immobiliser or engine stop switch fault, proceed to test 5
5 Reconnect harness, clear fault code and run engine to verify fault cleared	OK	Action complete - quit test
	Fault still present	Contact Triumph service

### Circuit Diagram

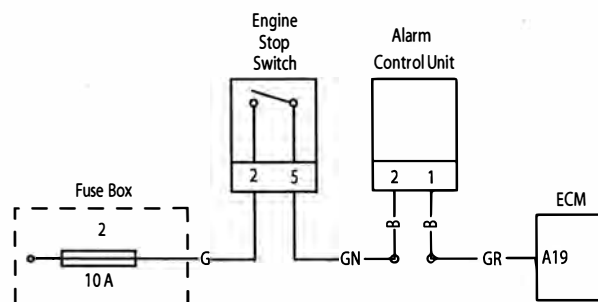

## 5 Volt Sensor Supply Circuit

Fault Code	Possible cause	Action
P1698	Sensor supply circuit shorted Sensor supply circuit shorted to ground Sensor supply circuit shorted to battery positive	View & note 'sensor' data. Note ECM sensors requiring a power supply will not be active. Disconnect ECM and proceed to pinpoint test 1:

### Pinpoint Tests

Test	Result	Action
1 Check cable and terminal integrity: - ECM pin B01 - ECM pin B20	OK	Proceed to test 2
	Faulty	Rectify fault, proceed to test 5
2 Check cable for short circuit - ECM pin B01 to ECM pin B20	OK	Proceed to test 4
	Faulty	Proceed to test 3
3 Disconnect the following sensors in turn:  - MAP sensor - Ambient pressure sensor - Throttle position switch - Exhaust control valve actuator - Fall detection sensor and retest for short circuit - ECM pin B01 to ECM pin B20	OK	Replace sensor last removed and proceed to test 5
	Faulty	Proceed to test 4
4 Check cable for short circuit: - ECM pin B01 to ground - ECM pin B20 to ground - ECM pin B01 to A06 - ECM pin B20 to A06 - ECM pin B01 to battery positive - ECM pin B20 to battery positive	OK	Proceed to test 5
	Short circuit	Locate and rectify wiring fault, proceed to test 5
5 Reconnect harness, clear fault code and use service software to check for correct sensor outputs and 5V sensor supply voltage level	OK	Action complete - quit test
	Fault still present	Contact Triumph service

### Circuit Diagram

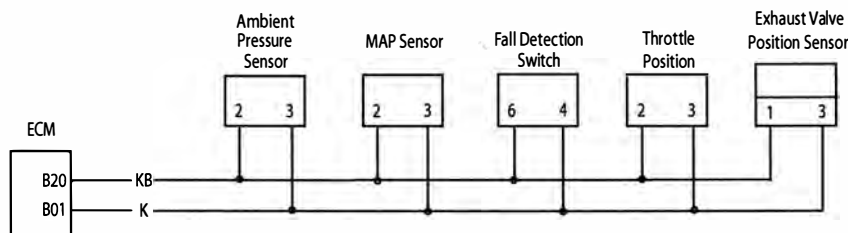

# Fuel System/Engine Management

---

## Tune Lock

Fault Code	Possible cause	Action
P1602	ECM is locked to prevent the motorcycle from being operated	This is also identified by a fast flashing MIL indication, and a disabled engine management system. Unlock the ECM using the diagnostic software and supplied unlock code from Triumph service.

## ECM or Tune ID Incorrect

Fault Code	Possible cause	Action
P1614	ECM or tune is incorrect, causing the ECM to be disabled to prevent the motorcycle from being operated	This is also identified by a fast flashing MIL indication, and a disabled engine management system.

## Pinpoint Tests

Test	Result	Action
1 Check ECM part number is correct for the motorcycle	OK	Proceed to test 2
	Incorrect	Replace ECM with correct part and proceed to test 3
2 Check that the tune is correct for the motorcycle, using the diagnostic software	OK	Proceed to test 3
	Incorrect	Update tune using the diagnostic software, proceed to test 3
3 Clear fault code, check for normal operation	OK	Action complete - quit test
	Fault still present	Contact Triumph service

# Fuel System/Engine Management

## Immobiliser and TPMS Control Module Communication

Fault Code	Possible cause	Action
P1650	Fault in CAN communication between ECM and immobiliser and TPMS control module	View & note 'freeze frame' data if available. Ensure immobiliser and TPMS control module connector is secure. Ensure the ignition switch is turned to the OFF position. Proceed to pinpoint test 1:

### Pinpoint Tests

Test	Result	Action
1 Check cable and terminal integrity: - ECM pin B28 - ECM pin B27 - Immobiliser pin 1 - Immobiliser pin 6	OK	Disconnect ECM and proceed to test 2
	Faulty	Rectify fault, proceed to test 4
2 Check cable for short circuit:  - ECM pin B28 to ground - ECM pin B27 to ground	OK	Disconnect immobiliser, ignition switch and proceed to test 3
	Faulty	Locate and rectify wiring fault, proceed to test 4
3 Check cable continuity: - ECM pin B28 to immobiliser pin 6 - ECM pin B27 to immobiliser pin 1 - Immobiliser pin 7 to ground - Ignition switch pin 5 to immobiliser pin 2 - Ignition switch pin 5 to immobiliser pin 8	OK	Contact Triumph service
	Fault still present	Locate and rectify wiring fault, proceed to test 4
3 Reconnect harness, clear fault code and run engine	OK	Action complete, quit test
	Fault still present	Contact Triumph service

### Circuit Diagram

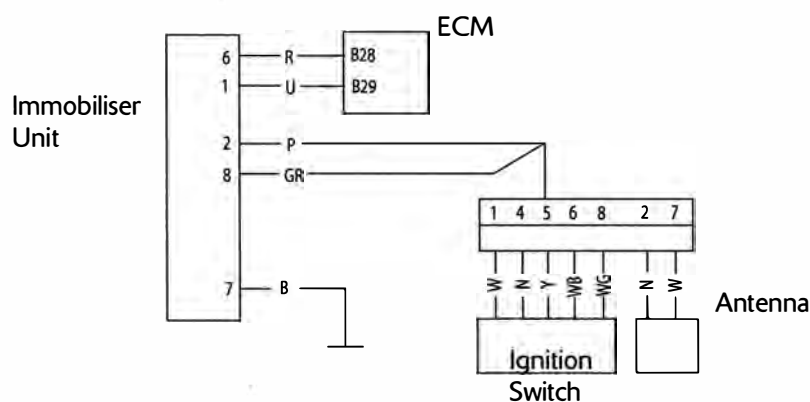



## Immobiliser and TPMS Control Module ID Incompatible

<b>Fault Code</b>	<b>Possible cause</b>	<b>Action</b>
P1508	There is a mismatch between the ECM and the immobiliser and TPMS control module, causing the ECM to be disabled to prevent the motorcycle from being operated	This is also identified by a fast flashing MIL indication and a disabled engine management system.

### Pinpoint Tests

<b>Test</b>	<b>Result</b>	<b>Action</b>
1 Follow the Pair ECM and Immobilise procedure as described in the Triumph Diagnostic Tool user guide	OK	Action complete, quit test
	Fault still present	Contact Triumph service

## Fuel System/Engine Management

---

### ABS Modulator ID Incompatible

Fault Code	Possible cause	Action
P1520	There is a mismatch between the ECM and the ABS modulator, causing the ECM to be disabled to prevent the motorcycle from being operated	Check ABS modulator part number is correct for the motorcycle

## ABS Modulator Communication

Fault Code	Possible cause	Action
P1521	Fault in CAN communication between ECM and ABS modulator	View & note 'freeze frame' data if available. Ensure ABS modulator connector is secure. Proceed to pinpoint test 1:

### Pinpoint Test

Test	Result	Action
1 Check cable and terminal integrity: - ECM pin B28 - ECM pin B27 - ABS modulator pin 1 - ABS modulator pin 17	OK	Disconnect ECM and proceed to test 2
	Faulty	Rectify fault, proceed to test 4
2 Check cable for short circuit: - ECM pin B28 to ground - ECM pin B27 to ground	OK	Disconnect ABS modulator and proceed to test 3
	Faulty	Locate and rectify wiring fault, proceed to test 4
3 Check cable continuity: - ECM pin B28 to ABS modulator pin 1 - ECM pin B27 to ABS modulator pin 17	OK	Contact Triumph service
	Fault still present	Locate and rectify wiring fault, proceed to test 4
3 Reconnect harness, clear fault code and run engine	OK	Action complete, quit test
	Fault still present	Contact Triumph service

### Circuit Diagram

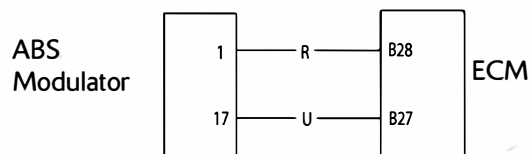

# Fuel System/Engine Management

## Fault Finding - Non Electrical

Symptom	Possible cause(s)
Poor throttle response at low RPM	Low fuel pressure caused by filter blockage/leaks
Cutting out at idle	Throttle bodies out of balance
	ISC (Idle Speed Control) actuator inoperative
	Low fuel pressure
	Weak mixture caused by air leak at the throttle body/transition piece to cylinder head face
Idle speed too low/high	ISC (Idle Speed Control) actuator sticking
	Incorrect closed throttle position setting
	Mechanical fault with the throttle linkage
Diagnostic software malfunctions during tune download procedure	Low battery voltage
Throttle hang-up	Incorrect closed throttle position setting
Motorcycle will start but cuts out immediately	ISC motor stuck
	Low fuel pressure caused by filter blockage/leaks
Abnormally high fuel pressure	Fuel pressure regulator inoperative
Temperature gauge reads cooler than normal	Cooling system air-locked resulting in coolant temperature sensor operating in air instead of coolant
Motorcycle will not start	Check the immobiliser system for faults
	Ensure that the keys, ECM and immobiliser/TPMS control module are all correctly paired

## Front Wheel Unit Sensor Battery Alert

**Note:**

- **All the fault codes for the tyre pressure monitoring system and the immobiliser system can only be viewed in the Safety/Security section of the Triumph diagnostic software.**

<b>Fault Code</b>	<b>Possible cause</b>	<b>Action</b>
L0001 or The TPMS tyre symbol in the instrument pack will be on for 8 seconds with the 'F' symbol with 'lo bAtt' shown in the display screen	Low battery voltage	Replace the front wheel pressure sensor following the procedure described in the Triumph diagnostic tool user guide.  Record the new sensor's ID number into the owner handbook before fitting.

## Fuel System/Engine Management

---

### Rear Wheel Unit Sensor Battery Alert

Fault Code	Possible cause	Action
L0002 or The TPMS tyre symbol in the instrument pack will be on for 8 seconds with the 'F' symbol with 'lo bAtt' shown in the display screen	Low battery voltage	Replace the rear wheel pressure sensor following the procedure described in the Triumph diagnostic tool. user guide.  Record the new sensor's ID number into the owner handbook before fitting.

### Front Wheel Unit Sensor Fault Alert

Fault Code	Possible cause	Action
L0003	The front wheel pressure sensor has detected a hardware error. Note: This DTC will automatically be generated if DTC L0007 occurs	If the problem persists: Replace the front wheel pressure sensor following the procedure described in the Triumph diagnostic tool user guide. Record the new sensor's ID number into the owner handbook before fitting.

# Fuel System/Engine Management

---

## Rear Wheel Unit Sensor Fault Alert

Fault Code	Possible cause	Action
L0004	The rear wheel pressure sensor has detected a hardware error. Note: This DTC will automatically be generated if DTC L0007 occurs	If the problem persists: Replace the rear wheel pressure sensor following the procedure described in the Triumph diagnostic tool user guide. Record the new sensor's ID number into the owner handbook before fitting.



## Front Wheel Unit Sensor Loss of Communication

**Note:**

- Refer to the owner's handbook for the wheel pressure sensors ID numbers.

Fault Code	Possible cause	Action
L0005	Immobiliser/TPMS control module has lost communication with the front wheel sensor unit. Low battery voltage. Wrong sensor ID number has been registered in the immobiliser/TPMS control module	If the problem persists: Using the Triumph diagnostic tool, check that the correct ID number for the front wheel pressure sensor is registered to the Immobiliser/TPMS control module. Replace the front wheel pressure sensor following the procedure described in the Triumph diagnostic tool user guide. Record the new sensor's ID number into the owner handbook before fitting.

# Fuel System/Engine Management

---

## Rear Wheel Unit Sensor Loss of Communication

**Note:**

- Refer to the owner's handbook for the wheel pressure sensors ID numbers.

Fault Code	Possible cause	Action
L0006	Immobiliser/TPMS control module has lost communication with the rear wheel sensor unit. Low battery voltage. Wrong sensor ID number has been registered in the immobiliser/TPMS control module	If the problem persists: Using the Triumph diagnostic tool, check that the correct ID number for the rear wheel pressure sensor is registered to the Immobiliser/TPMS control module. Replace the rear wheel pressure sensor following the procedure described in the Triumph diagnostic tool user guide. Record the new sensor's ID number into the owner handbook before fitting.

## Immobiliser/TPMS Control Module Fault

**Note:**

- Refer to the owner's handbook for the wheel pressure sensors ID numbers.

Fault Code	Possible cause	Action
L0007	Immobiliser/TPMS control module has lost communication with the front and rear wheel sensor units. Low battery voltage. Wrong sensor ID numbers have been registered in the immobiliser/TPMS control module	Using the Triumph diagnostic tool, check that the correct ID numbers for the wheel pressure sensors are registered to the Immobiliser/TPMS control module. If the correct IDs are registered, replace the front and rear wheel pressure sensor following the procedure described in the Triumph diagnostic tool user guide. Record the new sensor's ID number into the owner handbook before fitting.

# Fuel System/Engine Management

## Invalid Key: Key Authentication Unsuccessful

Fault Code	Possible cause	Action
L0008 or Alarm/immobiliser warning indicator light is on when the ignition switch is at the ON position (only visible on motorcycles without the accessory alarm fitted)	Immobiliser/TPMS control module cannot identify the transponder chip in the key	Check that the key has been registered with the immobiliser/TPMS control module, if it is a new key or an additional key.  Check that there are no additional keys with a transponder chip fitted close to the ignition key and proceed to pinpoint test 1:

### Pinpoint Tests

Test	Result	Action
1 If available, try to start the motorcycle with the second registered key:	OK	Transponder chip in the key not functioning correctly. Register a new key using the Triumph diagnostic tool then proceed to test 5
	Faulty	Proceed to test 2
2 Check the condition of cable, connector housing and terminals for the following: - Ignition switch - Immobiliser and TPMS control module	OK	Disconnect the ignition switch, proceed to test 3
	Faulty	Rectify fault, proceed to test 5
3 Check antenna coil resistance: - Ignition switch pin 2 to ignition switch pin 7	7Ω to 13Ω	Proceed to test 4
	Faulty	Replace the ignition switch, register new keys and proceed to test 5
4 Check cable continuity: - Ignition switch pin 7 to Immobiliser and TPMS control module pin 10 - Ignition switch pin 2 to Immobiliser and TPMS control module pin 5	OK	Contact Triumph service
	Faulty	Rectify fault, proceed to test 5
5 Reconnect harness, clear fault code and run engine	OK	Action complete - quit test
	Fault still present	Contact Triumph service

### Circuit Diagram

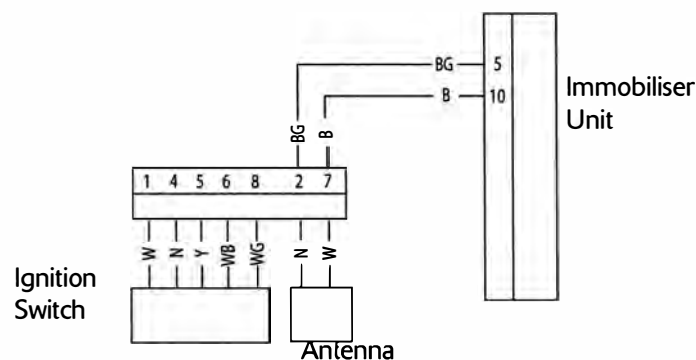

## Fuel Tank

### Removal

#### Warning

Observe the warning advice given in the general information section on the safe handling of fuel and fuel containers.

A fire, causing personal injury and damage to property, could result from spilled fuel or fuel not handled or stored correctly.

1. Remove the rider's seat (see page 16-13).
2. Disconnect the battery, negative (black) lead first.
3. Remove the lower radiator panels (see page 16-14).
4. Remove the upper radiator panels (see page 16-14).
5. Remove the cockpit assembly (see page 16-17).
6. Remove the fuel tank infill panels (see page 16-18).
7. Release the two bolts securing the fuel tank to the frame.

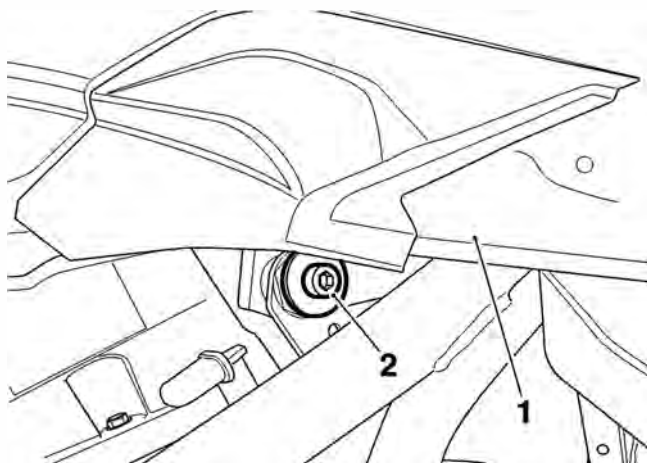

**1. Fuel tank**

**2. Fuel tank to frame bolt**

8. Raise the fuel tank and disconnect the electrical connections to the fuel pump and the fuel level sensor.

#### Warning

When disconnected, the fuel tank is self-sealing but a small amount of fuel may escape causing clothing and components to be coated with fuel.

This would represent a serious fire hazard which could lead to burn injuries and damage to property.

9. Ease the double check clip latch away from the connector until the release buttons are exposed.

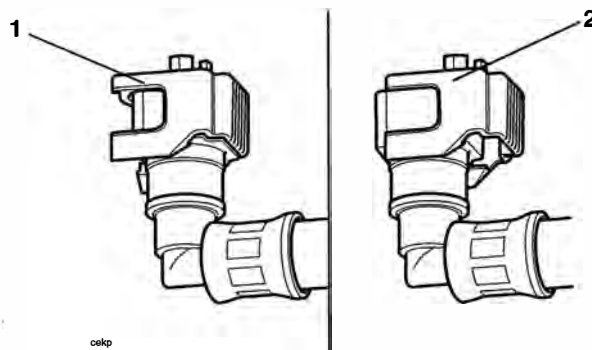

**1. Locked Position**

**2. Unlocked Position**

10. Disconnect the fuel hose by squeezing the sides of the connector and pulling the hose free from its spigot on the fuel pump plate.

# Fuel System/Engine Management

## Note:

- Before disconnection, note the position of the two breather hoses so that they can be returned to the same locations when refitting the tank.

11. Disconnect the two breather hoses.

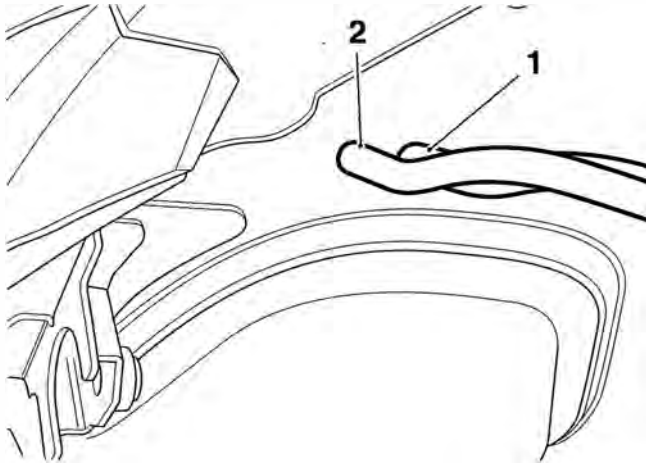

1. Breather hose - fuel tank vent

2. Breather hose - filler neck over flow

12. Remove the fuel tank from the frame.

## Installation

1. Position the fuel tank to the frame.
2. Connect the two breather hoses as previously noted.

## Note:

- The fuel hose has different coloured connectors on each end, to aid orientation. The grey end must be fitted to the fuel tank, the orange end must be fitted to the fuel rail.

3. Reconnect the fuel feed hose by gently pushing inwards until the hose engages with a click.
4. Slide the double check latch down (i.e. towards the spigot) until the release buttons are covered. If the latch will not slide into position, then the fuel hose is not fully home on its spigot and must therefore be refitted correctly.
5. Reconnect the fuel pump electrical connection.
6. Reconnect the fuel level sensor.

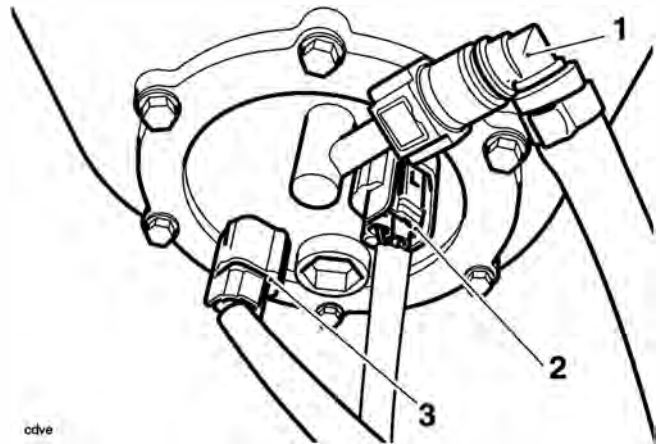

1. Fuel hose

2. Fuel pump electrical connection

3. Fuel level sensor connection

7. Align the fuel tank to the mounting points. Fit and tighten the two rear bolts to **12 Nm**.
8. Refit the fuel tank infill panels (see page 16-21).
9. Refit the cockpit assembly (see page 16-21).
10. Refit the upper radiator panels (see page 16-21).
11. Refit the lower radiator panels (see page 16-21).
12. Reconnect the battery, positive (red) lead first.
13. Start the engine and check carefully for fuel leaks. Rectify as necessary.
14. Refit the rider's seat (see page 16-13).

## Fuel Pump and Filter Assembly

### Removal

#### Note:

- **The fuel pump and fuel filter is a sealed for life unit and must be replaced as a complete assembly.**

1. Remove the rider's seat (see page 16-13).
2. Disconnect the battery, negative (black) lead first.
3. Remove the fuel tank (see page 10-91).
4. Drain the fuel tank into a suitable container.

### Warning

Observe the warning advice given in the general information section on the safe handling of fuel and fuel containers. A fire, causing personal injury and damage to property, could result from spilled fuel or fuel not handled or stored correctly.

5. Invert the fuel tank and place on a protective surface to prevent paint damage.
6. Remove the fixings securing the fuel pump mounting plate to the fuel tank.

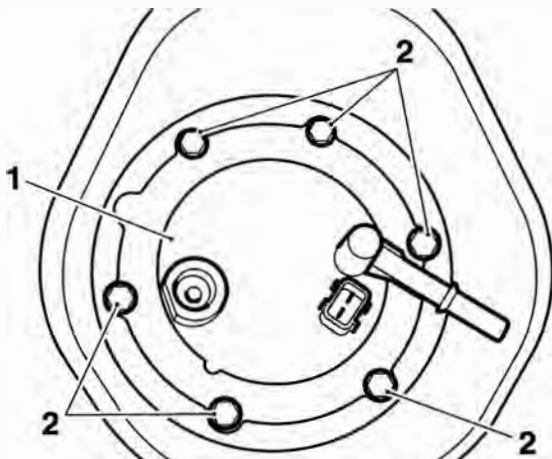

1. Mounting plate
2. Mounting plate fixings

7. Lift the fuel pump assembly and manoeuvre it from the fuel tank aperture.

8. Unhook the fuel level sender wiring from the hook on the fuel pump body.
9. Disconnect the fuel level sensor electrical connector and remove the fuel pump and filter assembly.

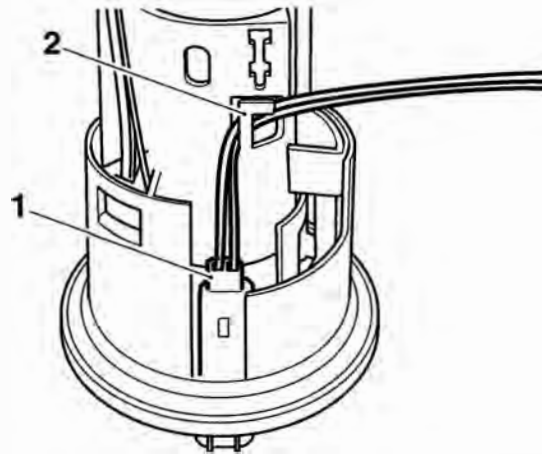

1. Fuel level sender connector
2. Hook

10. Noting its orientation, remove and discard the sealing ring from the fuel pump assembly.

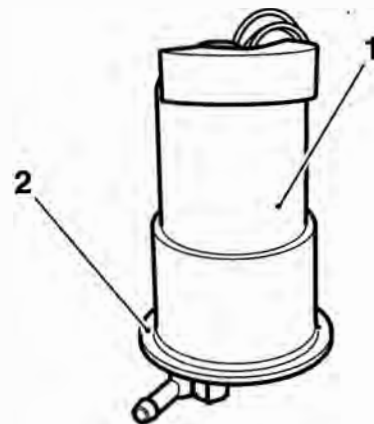

1. Fuel pump assembly
2. Sealing ring location

# Fuel System/Engine Management

## Installation

1. Install a new sealing ring in the fuel pump assembly, with the seal lip facing uppermost, and ensure that it is correctly seated.

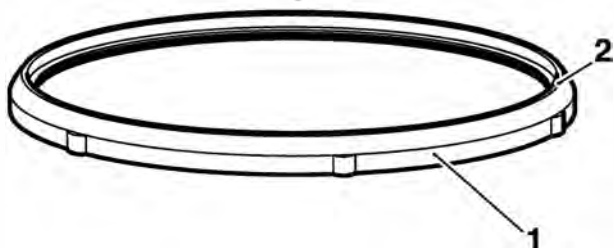

cdva

1. Sealing ring
2. Seal lip

2. Taking care to ensure the sealing ring is not damaged or dislodged, manoeuvre the fuel pump assembly into the fuel tank aperture.
3. Reconnect the fuel level sensor electrical connector and hook the wiring behind the hook on the fuel pump body.

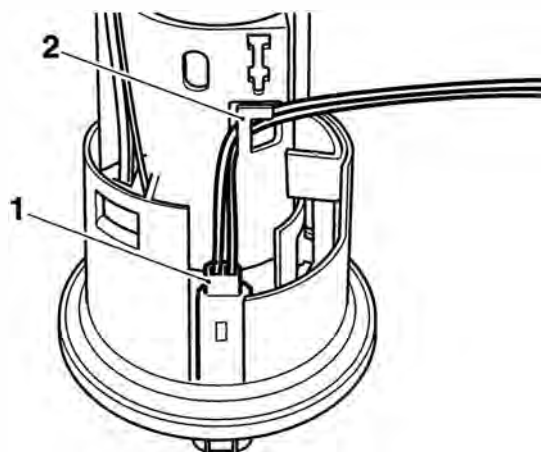

1. Fuel level sender connector
2. Hook



### Caution

Routing the fuel level sender wiring over the fuel level sender arm will prevent the sender arm from moving through its full range of movement, causing incorrect fuel gauge readings.

4. Check that the fuel level sender wiring is not routed over the fuel level sender arm.
5. Locate the fuel pump and filter assembly to the fuel tank.

6. Ensure the locating peg on the fuel pump assembly is located in the cut out on the mounting plate and the offset hole is positioned as shown below.

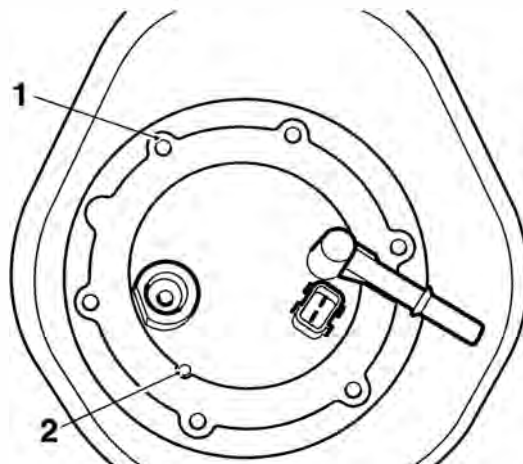

z

1. Offset hole position
2. Locating peg

7. In the sequence shown below, tighten the mounting plate fixings to **9 Nm**.

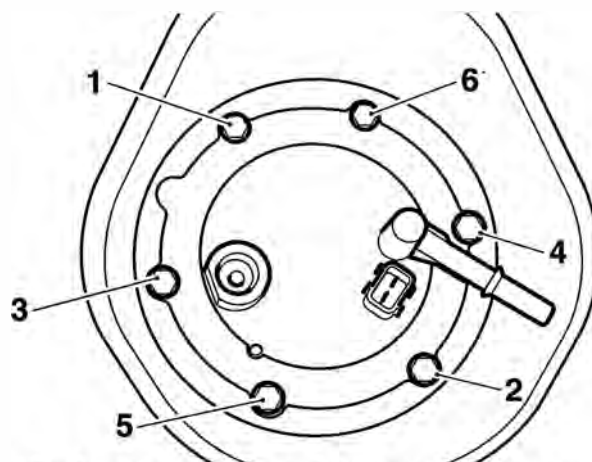

z

### Fuel pump mounting plate torque sequence

8. Refit the fuel tank (see page 10-92).
9. Refill the fuel tank with the fuel drained earlier.
10. Reconnect the battery, positive (red) lead first.
11. Start the engine and check carefully for fuel leaks. Rectify as necessary.
12. Refit the rider's seat (see page 16-13).



## Fuel Level Sender Assembly

### Removal

1. Remove the seat (see page 16-9).
2. Disconnect the battery, negative (black) lead first.
3. Remove the fuel pump and filter assembly (see page 10-93).
4. Working through the fuel pump aperture, release the two side tangs securing the fuel level sender to the bracket inside the fuel tank and carefully withdraw the fuel level sender.

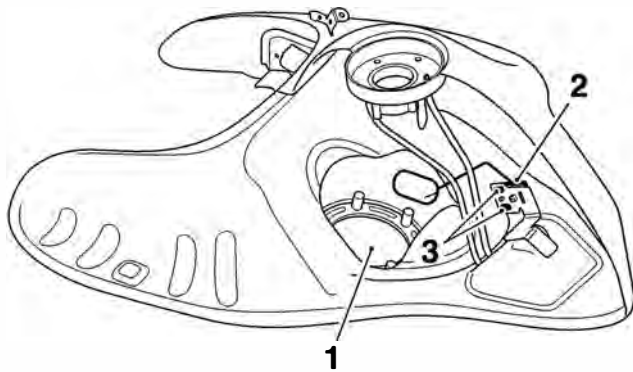

1. Fuel pump aperture
2. Fuel level sensor
3. Tangs

### Assembly

1. Refit the fuel level sender assembly to the fuel tank ensuring that the upper tang and two side tangs are correctly attached to the bracket inside the fuel tank.

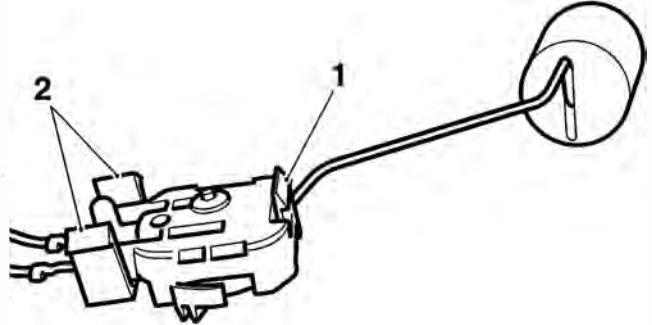

1. Upper tang
2. Side tangs



### Caution

Routing the fuel level sender wiring over the fuel level sender arm will prevent the sender arm from moving through its full range of movement, causing incorrect fuel gauge readings.

2. Check that the fuel level sender wiring is not routed over the fuel level sender arm.
3. Refit the fuel pump and filter assembly (see page 10-101).
4. Refill the fuel tank with the fuel drained earlier.
5. Reconnect the battery, positive (red) lead first.
6. Start the engine and check carefully for fuel leaks. Rectify as necessary.
7. Refit the seat (see page 16-9).

# Fuel System/Engine Management

## Fuel Pressure Checking

### Warning

Observe the fuel handling precautions given in the general information section.

Fuel pressure is checked using service tool T3880001.

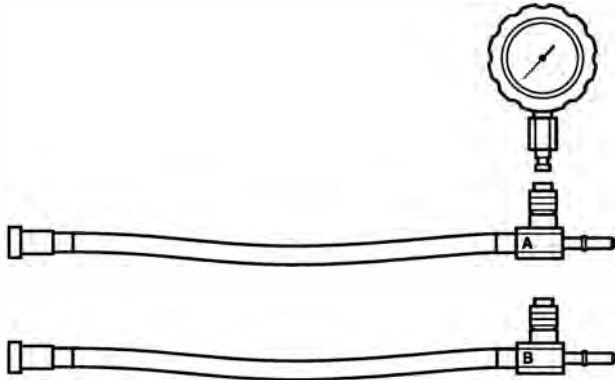

odgh

### Tool T3880001

1. Remove the rider's seat (see page 16-13).
2. Remove the fuel tank (see page 10-91) and place on a suitable support, close to the motorcycle.
3. Using the extension cable T3880123, carefully connect the fuel pump connection to the fuel tank. Connect the other end of the extension cable to the motorcycle main harness.
4. Select the fuel pressure gauge adapter marked 'B' from service tool T3880001.

### Warning

Always use the correct fuel pressure gauge adapter (**adapter 'B' for Tiger 800 and Tiger 800XC**). Use of an incorrect adapter will result in a fuel leak. A fuel leak can result in a fire causing damage to property and injury to persons.

5. Connect the adapter hose to the fuel pump plate outlet as shown in the illustration below.

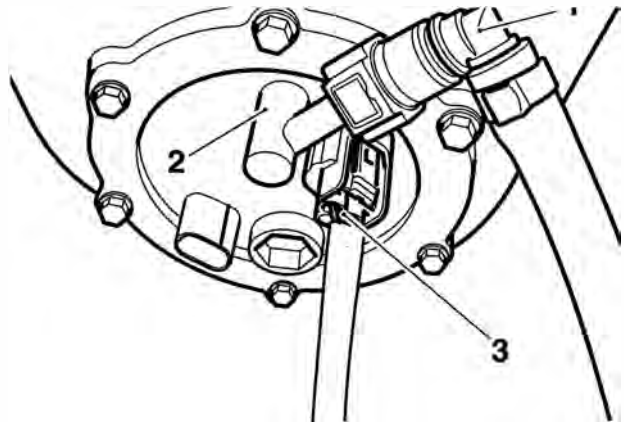

1. Adaptor hose 'B'
2. Fuel pump plate outlet
3. Extension cable T3880123

6. Connect the fuel hose to the adaptor hose as shown in the illustration below.

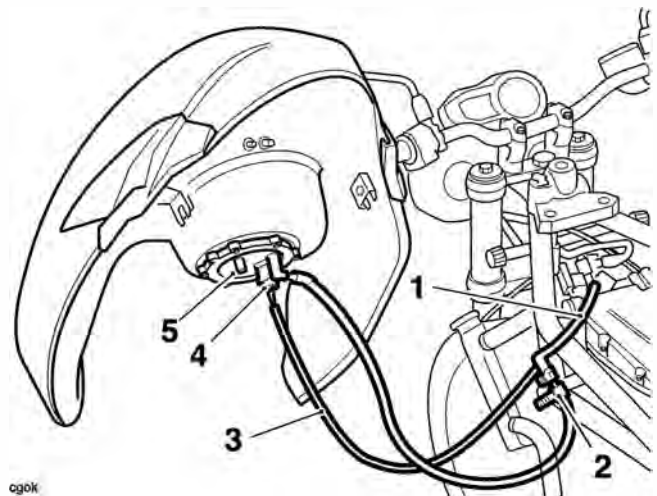

cgok

1. Motorcycle fuel hose
2. Adaptor hose 'B'
3. Wiring extension T3880123
4. Fuel pump connection
5. Fuel pump plate outlet

7. Connect the fuel pressure gauge to the adaptor hose as shown below by pushing the gauge spigot into adapter until a click can be heard.

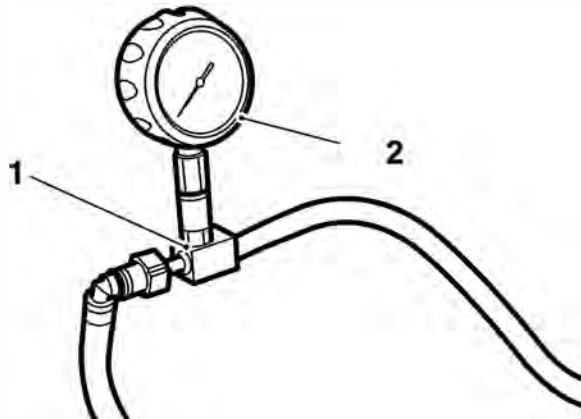

cdvr

1. Adaptor hose
2. Fuel pressure gauge

**Note:**

- To release the fuel pressure gauge from the adapter, slide the outer ferrule downwards. This will allow the gauge to spring upwards from the adapter.
8. Ensure the gauge is visible to the side of the motorcycle.
  9. Start the engine and observe the fuel pressure reading on the gauge.

**Note:**

- The fuel pressure should be 3.0 bar nominally.
10. When fuel pressure checking is complete, disconnect the fuel pressure gauge adapter and wiring extension.
  11. Refit the fuel tank (see page 10-92).
  12. Refit the rider's seat (see page 16-13).

## Fuel Delivery System

Fuel is delivered to the injectors by a pump located inside the fuel tank. Fuel flows in the direction of the arrows shown in the diagram below.

Incorporated in the fuel pump assembly is a filter, a pressure regulator and a pick-up strainer. The fuel pump assembly also contains the low fuel level sensor.

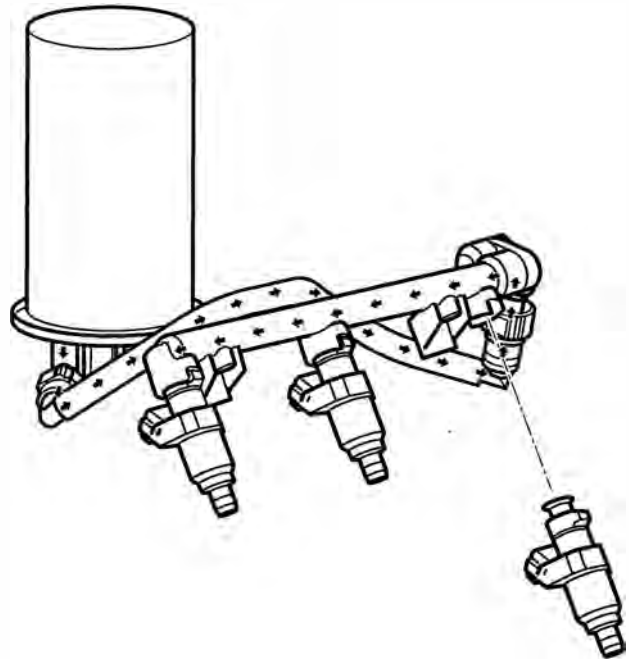

**Direction of Fuel Flow**

# Fuel System/Engine Management

## Airbox

### Removal

1. Remove the rider's seat (see page 16-13).
2. Disconnect the battery, negative (black) lead first.
3. Remove the fixing and remove the air intake duct from the airbox.

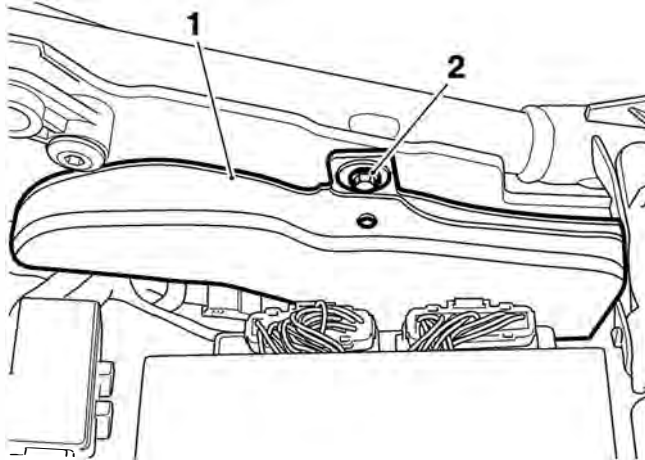

1. Air intake duct
2. Fixing

4. Remove the fuel tank (see page 10-91).
5. Disconnect the intake air temperature sensor multi-plug.

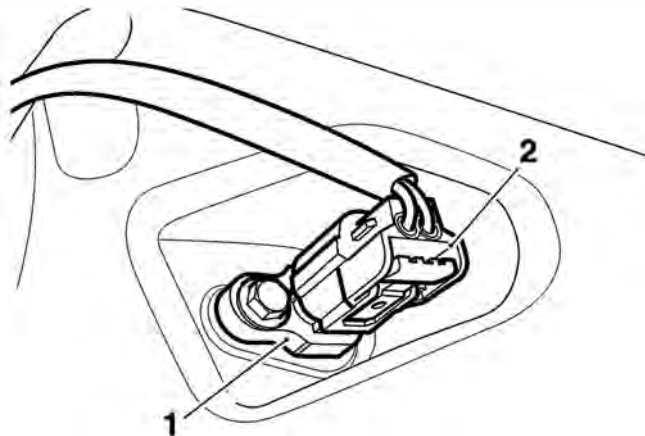

1. Intake air temperature sensor
2. Multi-plug

6. Disconnect the MAP sensor multi-plug and hose.

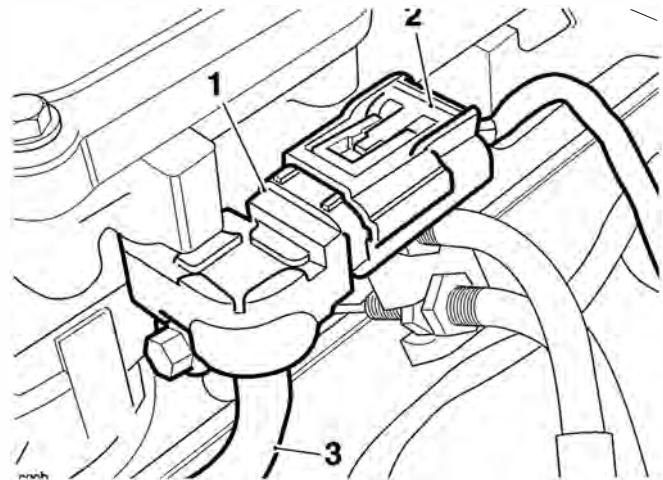

1. Map sensor
2. Multi-plug
3. Hose

7. Release the 11 fixings and remove the airbox upper section.

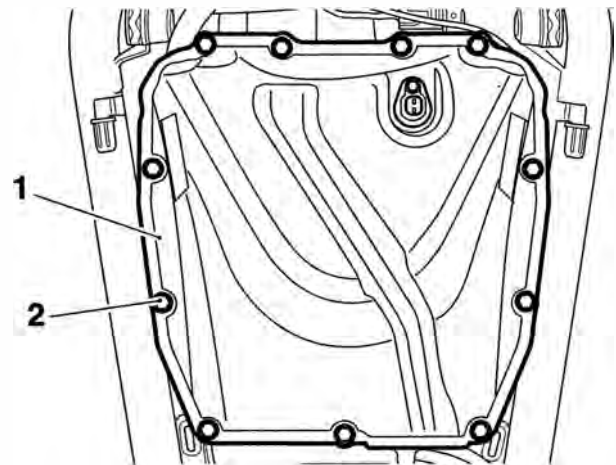

1. Airbox upper section
2. Fixings

8. Release the six fixings and remove the airbox intake trumpets.

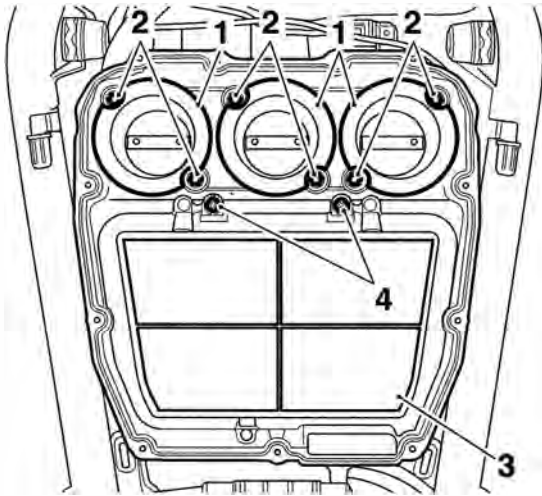

cgot

- 1. Airbox intake trumpet fixings
- 2. Air filter fixings
- 3. Air filter
- 4. Air filter fixings

9. Remove the two fixings and remove the air filter element.
10. Remove the airbox rear fixing, located below the air filter.

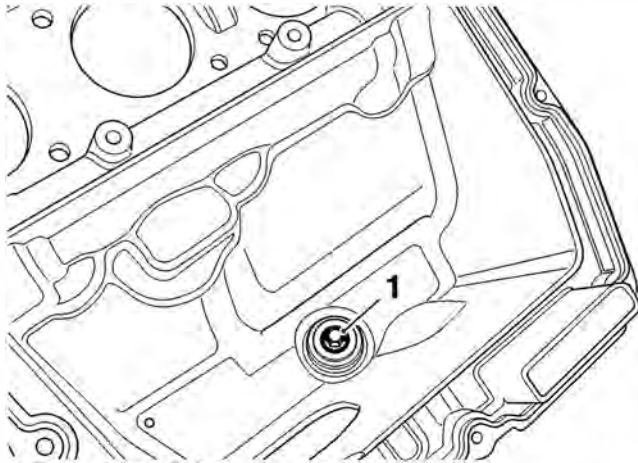

- 1. Rear airbox fixing

11. Raise the airbox and disconnect the engine breather hose at the airbox.

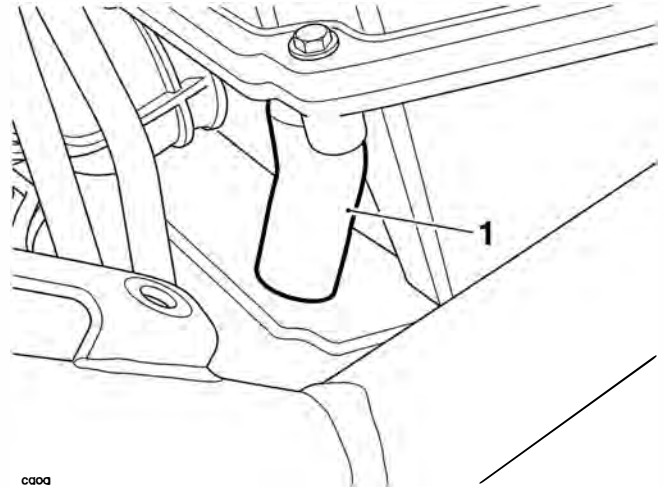

cgaa

- 1. Engine breather hose
- 2. Spring hose clip

12. Remove the airbox from the motorcycle.

## Inspection

- 1. Thoroughly clean the inside and outside of the airbox.
- 2. Check the airbox and intake trumpets for damage.

## Installation

1. Position the airbox to the motorcycle.
2. Connect the engine breather hose and refit the spring hose clip.
3. Align the airbox to the engine breather cover and secure using the rear fixing. Do not fully tighten at this stage.
4. Align the front of the airbox to the throttle bodies and fit the airbox intake trumpets. Tighten the fixings to **6 Nm**.
5. Tighten the airbox rear fixing to **9 Nm**.
6. Refit the air filter and tighten the fixings to **1 Nm**.
7. Refit the airbox upper section and tighten the fixings to **1.5 Nm**.
8. Reconnect the air temperature and MAP sensor multi-plugs.
9. Reconnect the MAP sensor hose.
10. Refit the fuel tank (see page 10-92).
11. Reconnect the battery, positive (red) lead first.
12. Refit the rider's seat (see page 16-13).

## Air Filter Element

### Removal

#### Note:

- **The air filter element can be accessed after first removing the airbox upper section. It is not necessary to remove the lower section.**

1. Remove the rider's seat (see page 16-13).
2. Disconnect the battery negative (black) lead first.
3. Remove the fuel tank (see page 10-91).
4. Remove the airbox upper section (see page 10-98).
5. Remove and discard the two fixings then remove the air filter element from the airbox lower section.

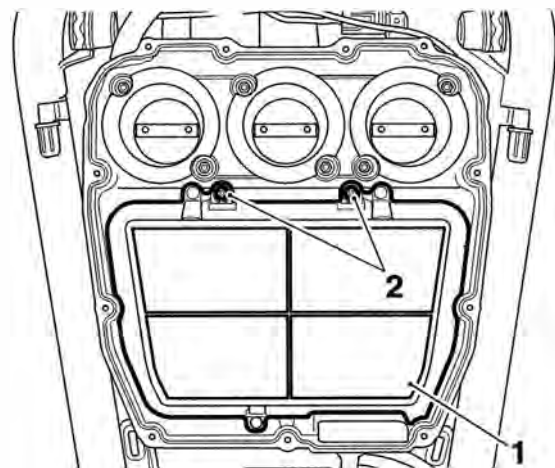

1. Air filter element

2. Fixings

### Installation

1. Thoroughly clean the inside and outside of the airbox.
2. Seat the air filter element in the lower section.
3. Secure the air filter element with new fixings. Tighten to **1 Nm**.
4. Refit the airbox upper section (see page 10-101).
5. Refit the fuel tank (see page 10-92).
6. Reconnect the battery, positive (red) lead first
7. Refit the rider's seat (see page 16-13).

## Intake Air Temperature Sensor

### Removal

1. Remove the rider's seat (see page 16-13).
2. Disconnect the battery, negative (black) lead first.
3. Remove the fuel tank (see page 10-91).
4. Disconnect the intake air temperature sensor multi-plug.

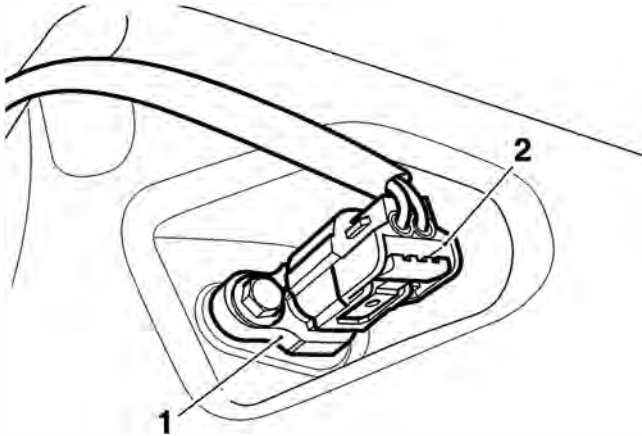

**1. Intake air temperature sensor**

**2. Multi-plug**

5. Remove and discard the sensor fixing.
6. Remove the sensor from the airbox.

### Installation

1. Fit the air temperature sensor to the airbox. Secure with a new screw and tighten to **1.5 Nm**.
2. Reconnect the intake air temperature sensor multi-plug.
3. Refit the fuel tank (see page 10-92).
4. Reconnect the battery, positive (red) lead first.
5. Refit the rider's seat (see page 16-13).

## MAP Sensor

### Removal

1. Remove the rider's seat (see page 16-13).
2. Disconnect the battery, negative (black) lead first.
3. Remove the fuel tank (see page 10-91).
4. Disconnect the MAP sensor multi-plug.

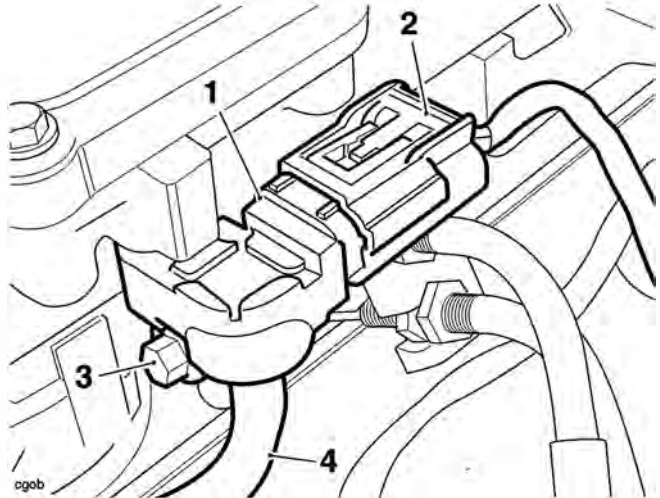

**1. MAP sensor**

**2. Multi-plug**

**3. Fixing**

**4. Vacuum hose**

5. Disconnect the vacuum hose from the sensor.
6. Release the fixing screw securing the sensor to the airbox and remove the sensor.

### Installation

1. Fit the sensor to the airbox, tightening the fixing to **1.5 Nm**.
2. Refit the vacuum hose.
3. Reconnect the MAP sensor multi-plug.
4. Refit the fuel tank (see page 10-92).
5. Reconnect the battery, positive (red) lead first.
6. Refit the rider's seat (see page 16-13).

# Fuel System/Engine Management

## Barometric Pressure Sensor

### Removal

#### Note:

- The barometric pressure sensor is located on the battery tray, under the battery.

1. Remove the rider's seat (see page 16-13).
2. Remove the battery (see page 17-8)
3. Disconnect the multi-plug.
4. Release the fixing securing the sensor to the battery tray and remove the sensor.

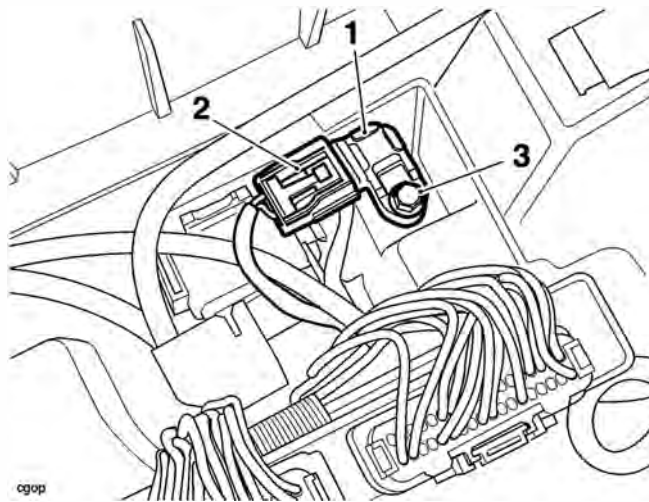

- cgop
1. Barometric pressure sensor
  2. Multi-plug
  3. Fixing

### Installation

1. Fit the sensor to the battery tray, tightening the fixing to **1.5 Nm**.
2. Reconnect the multi-plug.
3. Refit the battery (see page 17-8).
4. Refit the rider's seat (see page 16-13).

## Fall Detection Switch

### Removal

#### Note:

- The fall detection switch is located below the rear rack, forward of the rear light unit.

1. Remove the rider's seat (see page 16-13).
2. Disconnect the battery, negative (black) lead first.
3. Remove the rear rack (see page 16-20).
4. Disconnect the multi-plug.
5. Release the fixings securing the switch to the battery tray and remove the switch. Discard the fixings.

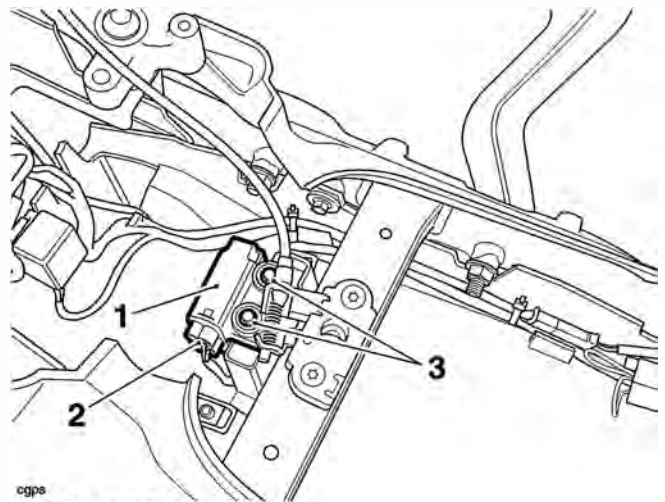

- cgps
1. Fall detection switch
  2. Multi-plug
  3. Fixings

### Installation

1. Fit the switch to the battery tray, secure with new fixings and tighten to **3 Nm**.
2. Reconnect the multi-plug.
3. Refit the rear rack (see page 16-21).
4. Reconnect the battery, positive (red) lead first.
5. Refit the rider's seat (see page 16-13).



## Crankshaft Position Sensor

### Removal

1. Remove the rider's seat (see page 16-13).
2. Disconnect the battery, negative (black) lead first.
3. Remove the alternator cover (see page 17-19).
4. Remove and discard the fixings and detach the cable guide from the crankcase.
5. Remove and discard the fixings and detach the sensor and cable guide from the crankcase.

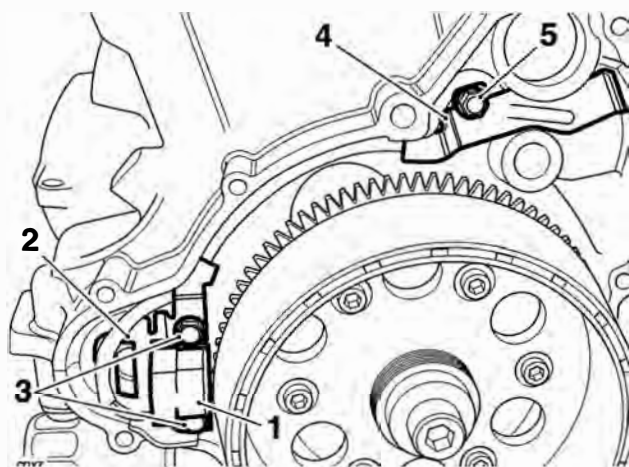

1. Crankshaft position sensor
2. Sensor cable guide
3. Sensor fixings
4. Upper cable guide
5. Cable guide fixing

6. Noting its routing, trace the sensor wiring back to the connector. Disconnect the sensor and detach it from the motorcycle.

### Installation

1. Position the sensor to the engine and route the wiring as noted prior to removal.

#### Note:

- **The air gap for the crankshaft position sensor is not adjustable.**
2. Retain the sensor with two new fixings. Tighten to **4 Nm**.
  3. Re-route the harness as noted during disassembly, and reconnect the sensor to the main wiring harness.
  4. Refit the alternator cover (see page 17-20).
  5. Reconnect the battery, positive (identified with red tape) lead first.
  6. Refit the rider's seat (see page 16-13).

## Immobiliser and TPMS Control Module

### Removal

1. Remove the rider's seat (see page 16-13).
2. Disconnect the battery, negative (black) lead first.
3. Remove the fuel tank (see page 10-97).
4. Disconnect the left and right hand switch cube multi-plugs and the immobiliser multi-plug.
5. Detach the female switch cube multiplug connectors from the frame bracket. It is not necessary to remove the immobiliser connector from the bracket.
6. Remove the two fixings and remove the immobiliser and TPMS control module.

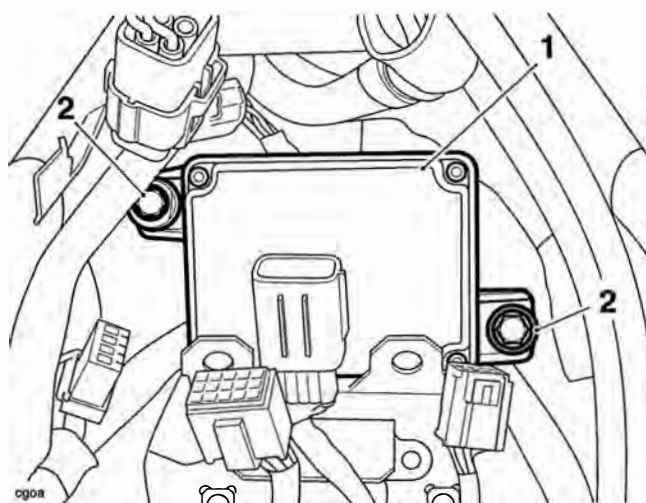

1. Immobiliser and TPMS control module
2. Fixings

### Installation

1. Installation is the reverse of removal, noting the following:
  - Tighten the fixings to **9 Nm**.

## Ignition Switch and Immobiliser Antenna

### Note:

- The immobiliser antenna is integral to the ignition switch and cannot be serviced separately.

### Removal

1. Remove the rider's seat (see page 16-13).
2. Disconnect the battery, negative (black) lead first.
3. Remove the fuel tank (see page 10-91).
4. Remove the two screws and remove the ignition switch cover.
5. Without damaging the ignition switch and using a suitable drill, carefully drill out the head of the shear bolts securing the ignition switch to the frame.

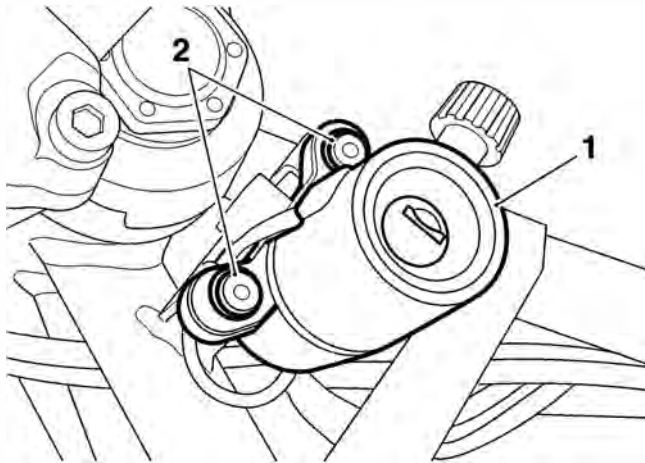

1. Ignition switch and immobiliser antenna

2. Shear bolts

6. Disconnect the ignition switch multiplug.
7. Noting the harness routing, remove ignition switch.
8. Remove the remainder of the shear bolt from the frame.

### Installation

1. Installation is the reverse of removal, noting the following:
  - Install new shear bolts and tighten until the heads shear off.

## Throttle Cable

### Adjustment

### Note:

- Minor adjustments to the opening cable can be made using the adjuster near the throttle grip end of the throttle. Where a correct setting cannot be achieved this way, the adjusters at the throttle end of both cables must be used. The opening cable must be set first followed by the closing cable.

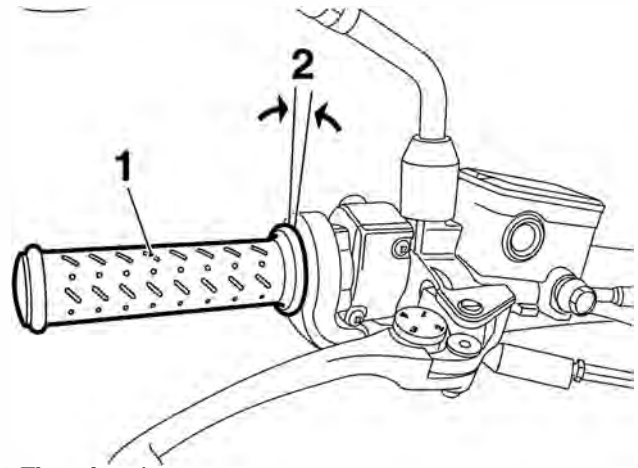

1. Throttle grip

2. Correct setting, 2-3 mm

1. Remove the rider's seat (see page 16-13).
2. Disconnect the battery, negative (black) lead first.
3. Set the 'opening' cable adjuster at the throttle grip end such that it has an equal amount of adjustment in each direction. Tighten the locknut.
4. Remove the fuel tank (see page 10-91).

- Set the 'opening' cable adjuster at the throttle body end to give 2-3 mm of play at the throttle grip. Tighten the locknut.

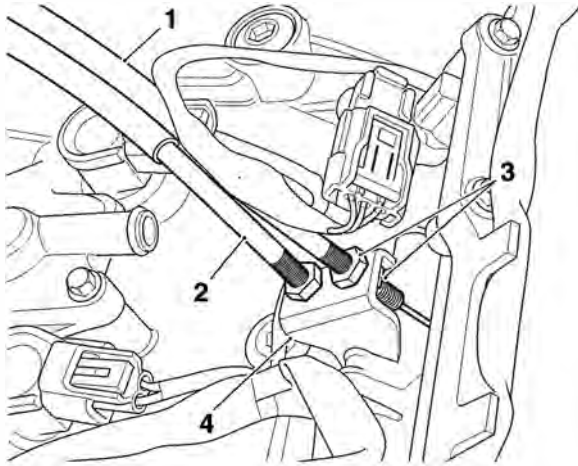

- Opening cable**
  - Closing cable**
  - 'Closing' cable adjuster (throttle end)**
  - Closing cable – free play measurement point**
- With the throttle fully closed, ensure that there is 2-3 mm of free play in the 'closing' cable. Adjust if necessary ensuring that the locknut is secure afterwards.

## Warning

Operation of the motorcycle with incorrectly adjusted, incorrectly routed or damaged throttle cables could interfere with the operation of the brakes, clutch or the throttle itself. Any of these conditions could result in loss of motorcycle control and an accident.

## Warning

Move the handlebars to left and right full lock while checking that cables and harnesses do not bind. Cables or harness that bind will restrict the steering and may cause loss of motorcycle control and an accident.

## Warning

Ensure that the adjuster locknuts are tightened. A loose throttle cable adjuster could cause the throttle to stick leading to loss of motorcycle control and an accident.

- Refit the fuel tank (see page 10-92).
- Reconnect the battery, positive (red) lead first.
- Refit the rider's seat (see page 16-13).

## Removal

### Note:

- Before beginning to remove the throttle cables, note the exact routing and location of both cables to help ensure that they are returned to the same locations and routing on assembly.

- Remove the rider's seat (see page 16-13).
- Disconnect the battery, negative (black) lead first. (see page 17-8).
- Remove the fuel tank (see page 10-91).
- Detach the throttle bodies (see page 10-107).
- Slacken the adjuster locknuts at the throttle body end of the cables such that they will allow the outer cables to be detached from the cable bracket.
- Detach the inner cable nipples from the throttle cam.

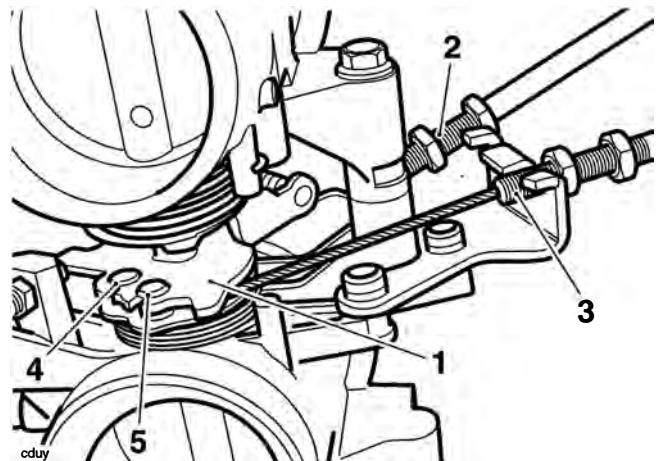

- Throttle cam**
- Opening cable**
- Closing cable**
- Opening cable nipple**
- Closing cable nipple**

# Fuel System/Engine Management

- At the throttle grip end, slide off the rubber boot and release the screws which secure the two halves of the throttle grip guide to each other.

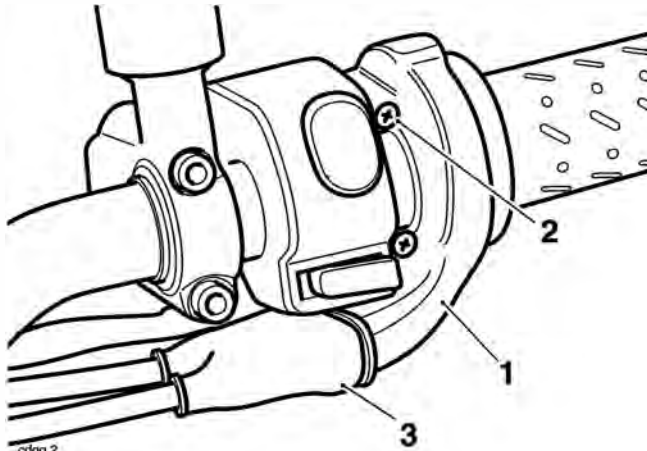

- cdgg 2
- Throttle grip guide
  - Screws
  - Rubber boot

- Separate the two halves of the guide then release the inner cables from the throttle grip.

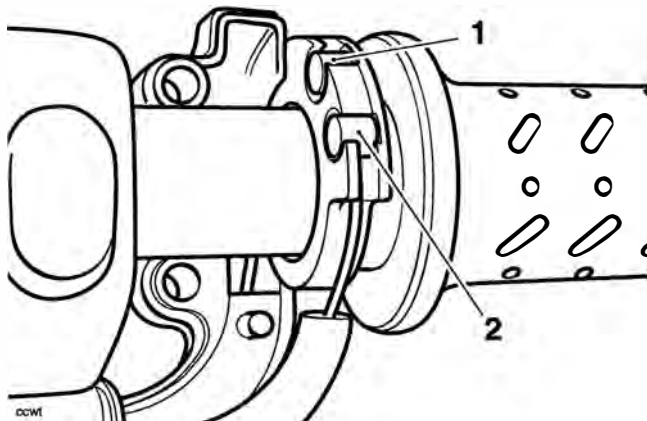

- ccwt
- Opening cable
  - Closing cable

- Detach the cables from the motorcycle.

## Inspection

- Check that both the throttle cables operate smoothly, without sticking or binding. Replace the cables if there is any doubt as to their correct operation.

## Installation

- Locate the cables to the frame following the routing noted during removal.
- Engage the inner cable nipples to the throttle grip, ensuring the 'opening' cable is located in the upper slot in the throttle grip, and the 'closing' cable is located to the lower slot.

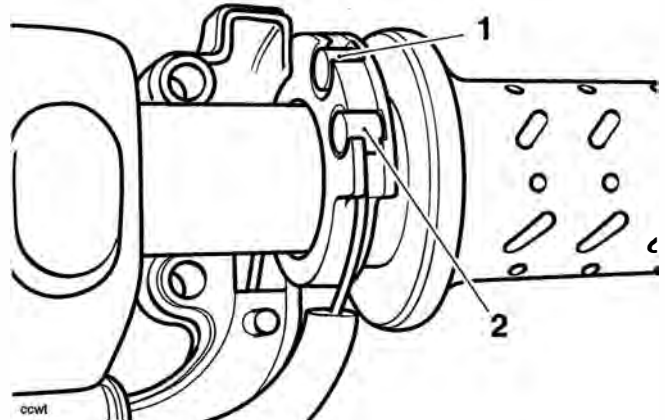

- ccwt
- Opening cable
  - Closing cable

- Assemble the two halves of the cable guide ensuring that the outer cables are correctly located in the guide and the guide is positioned on the handlebars as noted prior to removal. Fit and tighten the two screws to **3 Nm**.

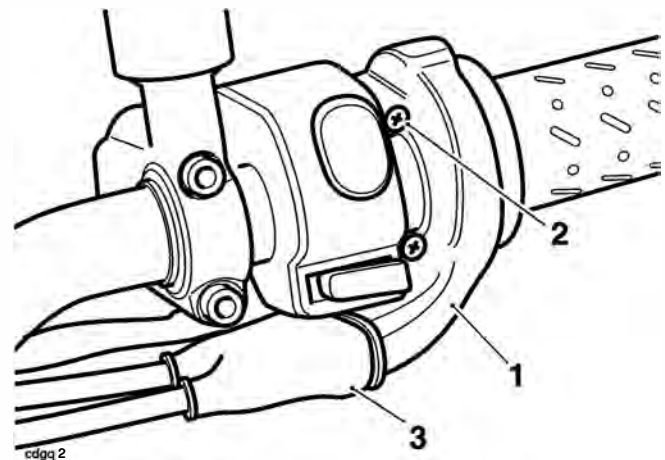

- cdgg 2
- Throttle grip guide
  - Screws
  - Rubber boot

- Refit the boot.
- Attach the other end of the inner cables to the throttle cam ensuring the 'opening' cable is fitted to the top of the cam and the 'closing' cable to the bottom.

6. Locate the outer cables to the bracket and adjust until the start of the thread is 14 mm away from the back of the throttle cable bracket. Secure the adjuster and locknuts.

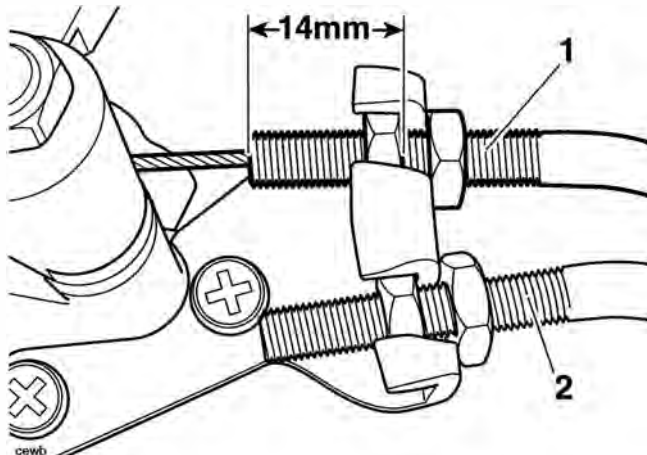

**1. Opening cable**

**2. Closing cable**

7. Refit the throttle bodies (see page 10-101).
8. Set the throttle cable adjustment (see page 10-104).
9. Refit the airbox (see page 10-101).
10. Refit the fuel tank (see page 10-92).
11. Reconnect the battery, positive (red) lead first
12. Refit the rider's seat (see page 16-13).

## Throttle Bodies/Injectors

### Removal

#### Note:

- Because fuel stored in the fuel rail will be at 3 bar pressure, it is essential that the fuel pressure is reduced before any dismantling of the fuel rail takes place. To reduce pressure, briefly crank the engine with the fuel pump disconnected.

### **!** Warning

If the fuel rail is dismantled without first reducing pressure fuel may escape causing clothing and components to be coated with fuel.

This would represent a serious fire hazard which could lead to burn injuries and damage to property.

1. Remove the rider's seat (see page 16-13).
2. Disconnect the battery, negative (black) lead first.
3. Remove the fuel tank (see page 10-91).
4. Remove the airbox (see page 10-98).
5. Disconnect the throttle position sensor multi-plug.
6. Disconnect the fuel injector multi-plugs.
7. Disconnect the idle speed control stepper motor multi-plug.
8. Release the clips securing the throttle bodies to the transition pieces.

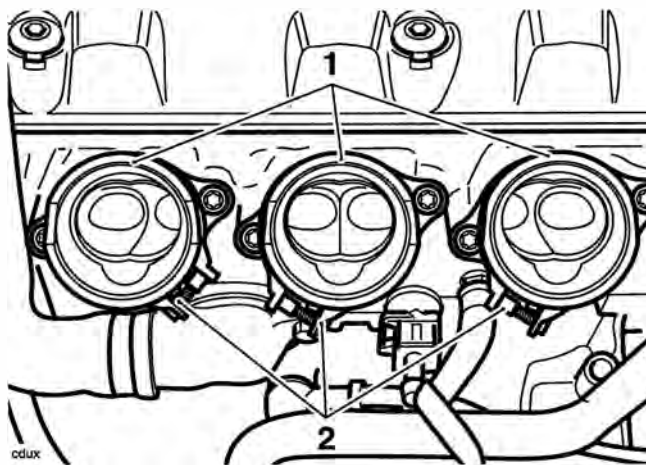

**1. Transition piece (one per cylinder)**

**2. Clip location (throttle bodies removed for clarity)**

9. Ease the throttle bodies from the transition pieces and lay the assembly carefully on the cam cover.
10. Release both throttle cables from the throttle cam (see page 10-105).

# Fuel System/Engine Management

11. Remove the throttle bodies.
12. If required, release the screws securing the fuel rail to the throttle bodies.

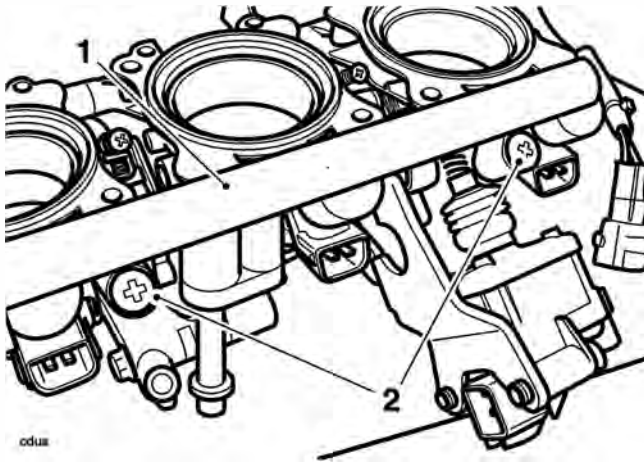

1. Fuel rail
2. Fuel rail screws

13. Ease the fuel rail and injectors from the throttle bodies.
14. To detach the injectors from the fuel rail, gently ease the injector from the rail.

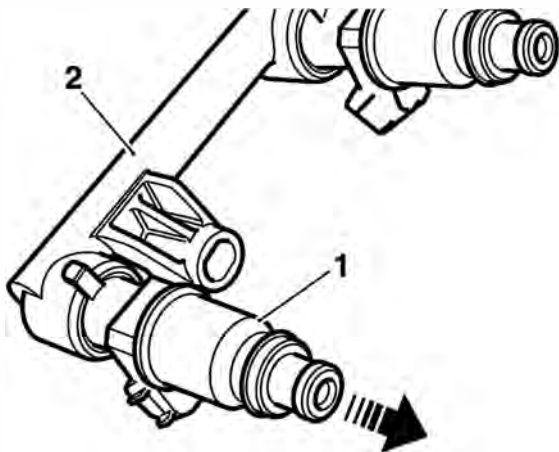

1. Injector
2. Fuel rail

15. To detach the transition pieces from the head, release the screws, raise the transition pieces and collect the O-rings.

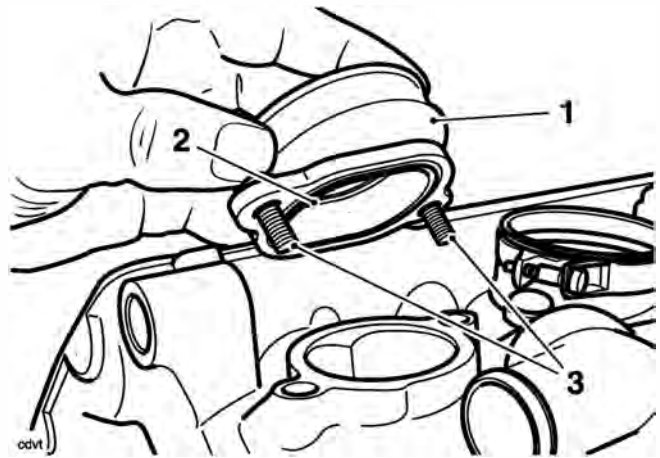

1. Transition piece
2. O-ring
3. Fixings

## Inspection

1. Check all joints and seals for splits, cuts and damage.
2. Check the throttles for sticking, loose or damaged throttle plates.
3. Check the transition piece O-rings for damage.

## Installation

1. Thoroughly clean the transition piece to cylinder head mating faces.
2. Refit the transition pieces to the head incorporating new O-rings to the joint face. Tighten the transition piece fixings to **12 Nm**.

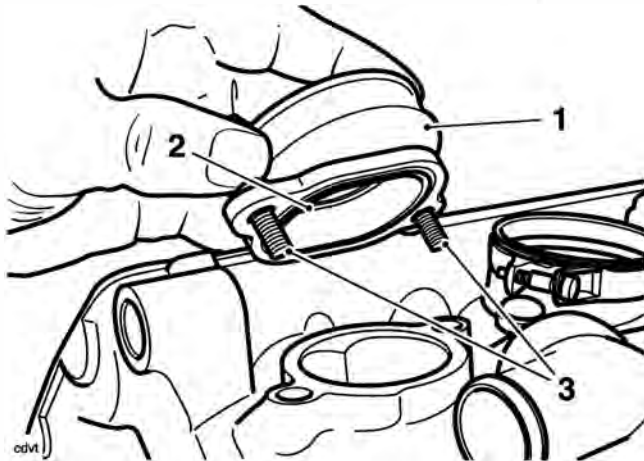

1. Transition piece
2. O-ring
3. Fixings

3. If the injectors have been removed from the fuel rail, refit them to the rail, ensuring the injector locating peg is fully engaged in the slot in the rail.

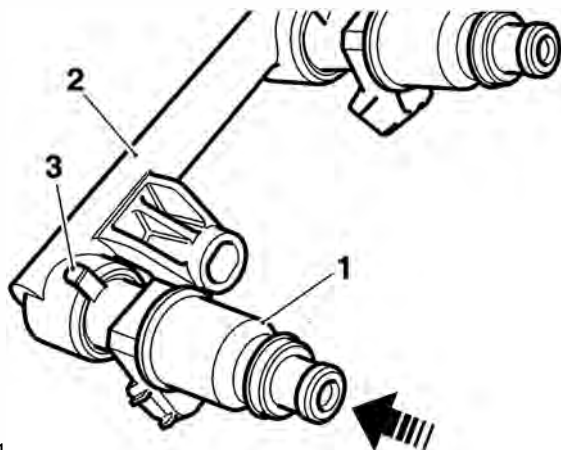

- cdvp1
1. Injector
  2. Fuel rail
  3. Locating peg

4. Check the injector O-rings for splits and other damage. Replace as necessary.

5. Refit the injectors and fuel rail to the throttle bodies. Tighten the fuel rail screws to **3.5 Nm**.

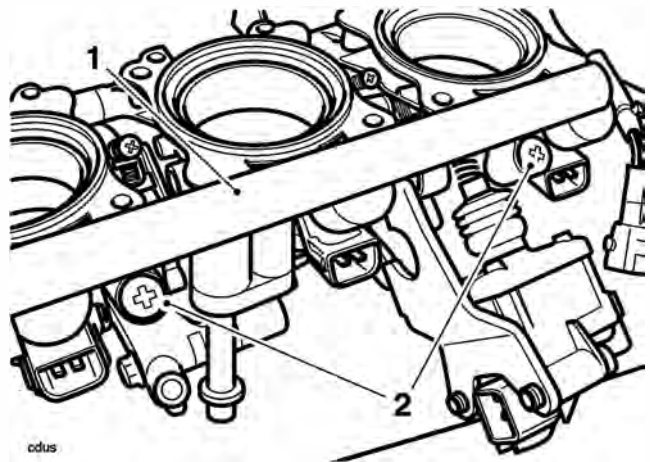

- cdus
1. Fuel rail
  2. Fuel rail screws

6. Re-attach the throttle cables (see page 10-104).

## Warning

The throttle body clips must be positioned as shown below. If the clips are not positioned as shown this could cause the throttle to stick, leading to loss of motorcycle control and an accident.

7. Refit the throttle bodies to the transition pieces and secure with the clips.

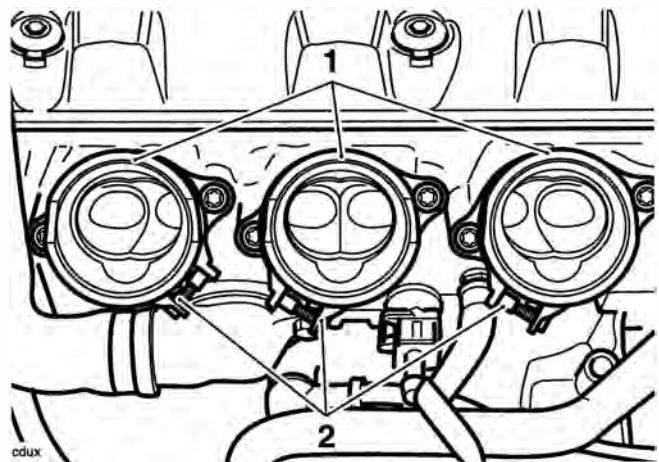

- cdus
1. Transition piece (one per cylinder)
  2. Clip location (throttle bodies removed for clarity)

8. Adjust the throttle cables (see page 10-104).
9. Reconnect the idle speed control stepper motor multi-plug.
10. Reconnect the fuel injector multi-plugs.
11. Reconnect the throttle position sensor multi-plug.
12. Refit the airbox (see page 10-101).
13. Refit the fuel tank (see page 10-92).
14. Reconnect the battery, positive (red) lead first.
15. Refit the rider's seat (see page 16-13).

## Throttle Body Balancing

### Note:

- **The throttles cannot be balanced using equipment to measure vacuum in each throttle. Instead, the Triumph diagnostic software must be used.**

1. Remove the rider's seat (see page 16-13).
2. Remove the fuel tank (see page 10-91) and place on a suitable support, close to the motorcycle.
3. Remove the airbox (see page 10-98).



### Warning

If the engine has recently been running, the components beneath the fuel tank may be hot to the touch.

4. Turn the ignition to the 'OFF' position.
5. Using the extension cable T3880123, carefully connect the fuel pump connection on the main harness to the fuel tank. Connect the other end of the harness extension to the motorcycle main harness.
6. Select the fuel pressure gauge adapter marked 'B' from service tool T3880001.



### Warning

Always use the correct fuel pressure gauge adapter (**adapter 'B' for Tiger 800 and Tiger 800XC**). Use of an incorrect adapter will result in a fuel leak. A fuel leak can result in a fire causing damage to property and injury to persons.

7. Connect the adapter hose to the fuel pump plate outlet as shown in the illustration below.

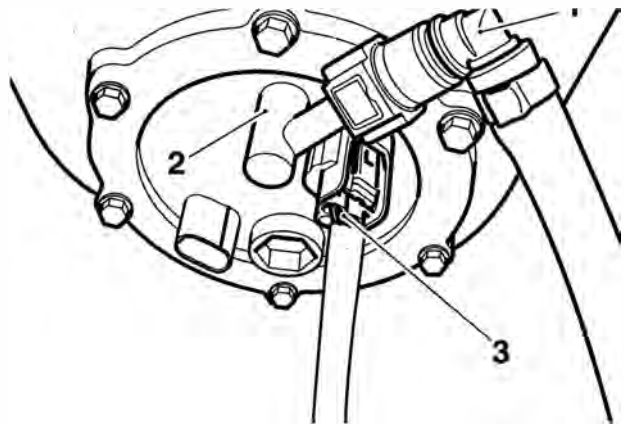

1. Adaptor hose 'B'
2. Fuel pump plate outlet
3. Tool T3880123

8. Connect the fuel hose to the adaptor hose as shown in the illustration below.

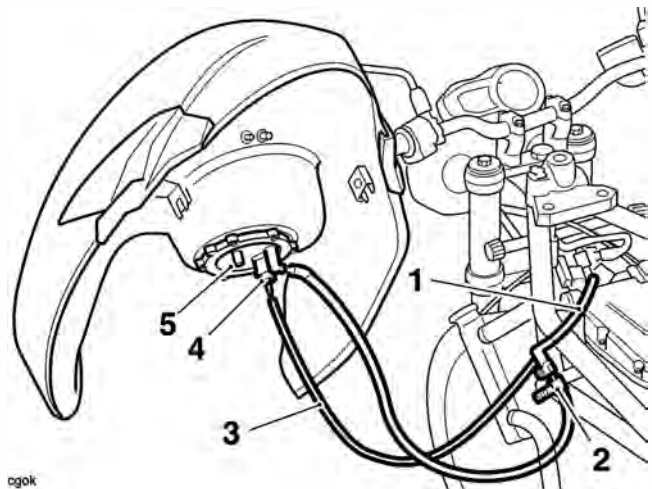

1. Motorcycle fuel hose
2. Adaptor hose 'B'
3. Fuel pump connection
4. Wiring extension T3880123
5. Fuel pump connection
6. Fuel pump plate outlet

9. Attach exhaust extraction hoses to the silencer.
10. Attach the Triumph diagnostic tool to the dedicated plug, refer to the Triumph Diagnostic Tool User Guide. Start the engine, and allow to idle.
11. On the diagnostic software navigate to 'ADJUST TUNE'.
12. Select 'BALANCE THROTTLES'.



13. Click the Adjust button.

## Adjust Tune Procedure

Adjust the throttle balance as described in the service manual until balanced  
Press cancel to cancel the adjustment process  
Press OK to finish

Throttle Status:	Throttles Balanced
Cylinder 1 MAP Pressure:	480 mmHg
Cylinder 2 MAP Pressure:	481 mmHg
Cylinder 3 MAP Pressure:	480 mmHg



Adjusting parameter - Balance Throttles

### Balance Throttles Screen

#### Note:

- **The balance throttle screen will show the vacuum value of each throttle in mm/Hg. In addition, when the throttles are balanced to an acceptable range of each other the word 'THROTTLES BALANCED' in green text will appear on the right of the screen. At this point, no further adjustment is necessary or productive.**
- **If the throttles are not balanced to each other the word 'THROTTLES UNBALANCED' in red text will appear on the right of the screen. At this point adjustment will be necessary.**
- **The adjusters operate on the outer cylinders only (cylinders 1 and 3). The centre throttle (cylinder 2) adjustment is fixed, this being controlled by the idle speed control stepper motor. Note that the centre reading will alter slightly as the two outer cylinders are adjusted.**
- **DO NOT attempt to adjust the centre throttle stop screw, located below the idle stepper motor. The stop screw is set at the factory during manufacture, and must not be adjusted.**

14. Using the throttle adjusters, make adjustments to the two outer cylinders until the word 'THROTTLES BALANCED' in green text appears.

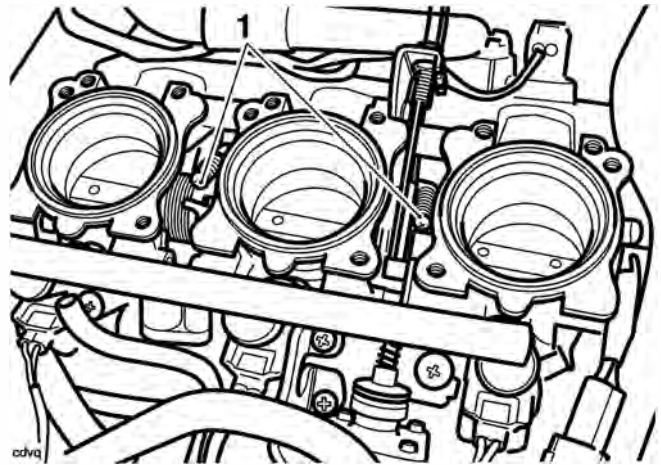

#### 1. Adjusters

15. When balanced, stop the engine and disconnect the diagnostic tool.
16. Disconnect the fuel pressure gauge adapter and wiring extension.
17. Refit the airbox (see page 10-101).
18. Refit the fuel tank (see page 10-92).
19. Remove the exhaust extraction hoses from the silencer.
20. Refit the rider's seat (see page 16-13).

## Throttle Position Sensor

### Removal

1. Remove the rider's seat (see page 16-13).
2. Disconnect the battery, negative (black) lead first.
3. Remove the fuel tank (see page 10-91).
4. Remove the airbox (see page 10-98).
5. Remove the throttle body assembly (see page 10-107).
6. Release the two screws and rotate the throttle position sensor clockwise through 45° to remove it from the left hand end of the throttle body. Collect the O-ring on disassembly.

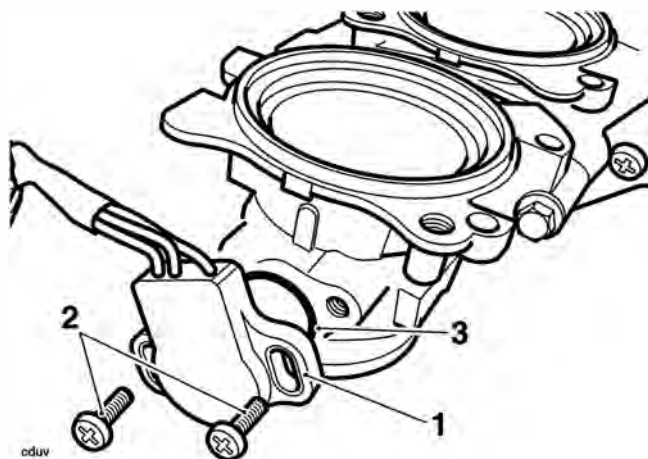

1. Throttle position sensor
2. Screws
3. O-ring

### Installation

1. Fit the replacement throttle position sensor ensuring the O-ring is positioned correctly between the sensor and throttle body. Rotate the sensor through 45° anti-clockwise until the screw holes align.
2. Engage the new screws and washers supplied and part tighten such that the sensor can still be rotated.
3. Position the throttle body assembly near to its fitted position and reconnect the sensor and all other throttle body electrical connectors.
4. Reconnect the battery, positive (red) lead first.
5. Attach the Triumph diagnostic tool to the dedicated plug, refer to the Triumph Diagnostic Tool User Guide.
6. Turn the ignition to the 'ON' position.
7. On the diagnostic software navigate to and select the 'ADJUST TUNE' option.

8. At the next screen, select Throttle Position Sensor Adjust then click the 'Adjust' button.
9. On pressing the adjust button, the diagnostic tool will send a command, which drives the primary throttle to the fully closed position. The tool will also display the voltage reading coming from the throttle position sensor.

### Adjust Tune Procedure

Adjust the throttle position sensor as described in the service manual until the voltage reading is within the range shown below Press OK when the adjustment is complete Press cancel to cancel the adjustment process	
Throttle Voltage:	0.59 V
Target Voltage Range:	0.58 V - 0.62 V
 Adjusting parameter - Throttle Position Sensor Adjust	

### Adjust Tune Screen

Gently rotate the new throttle position sensor until the voltage reading on the software shows 0.6 Volts +/- 0.02 Volts. The reading on the screen will turn green, indicating that the reading is correct.

### Note:

- **This is a setting voltage only. Because of the adaptive nature of the engine management system, the in-service voltage may vary from this setting figure.**
10. Tighten the sensor retaining screws to **2 Nm** and recheck the voltage reading shown on the tool. Repeat the adjustment if the reading is outside the specified range.
  11. Click on the OK button to return the throttle to normal control and return the diagnostic tool to the 'ADJUST TUNE' menu.
  12. Disconnect the diagnostic tool.
  13. Check that the throttle opens and closes without obstruction/sticking and has a smooth action throughout the full range of its movement. Rectify as necessary.

## Warning

Operation of the motorcycle with an incorrectly adjusted throttle position sensor, or a throttle position sensor that causes the throttle to stick could result in loss of throttle control. Loss of throttle control could result in loss of control of the motorcycle and an accident.

## Warning

Operation of the motorcycle with an incorrectly adjusted, incorrectly routed or damaged throttle cable could interfere with the operation of the brakes, clutch or the throttle itself. Any of these conditions could result in loss of control of the motorcycle and an accident.

14. Disconnect the battery, negative (black) lead first.
15. Refit the throttle body assembly (see page 10-101).
16. Refit the airbox (see page 10-101).
17. Refit the fuel tank (see page 10-92).
18. Reconnect the battery, positive (red) lead first.
19. Check and clear any stored faults using the diagnostic tool, refer to the Triumph Diagnostic Tool User Guide.
20. Refit the rider's seat (see page 16-13).

## Idle Speed Control Stepper Motor

### Removal

1. Remove the rider's seat (see page 16-13).
2. Disconnect the battery, negative (black) lead first.
3. Remove the fuel tank (see page 10-91).
4. Remove the airbox (see page 10-98).
5. Remove the throttle bodies (see page 10-101).
6. Remove the nut, metal washer and plastic washer attaching the idle control stepper arm to the idle speed control lever.

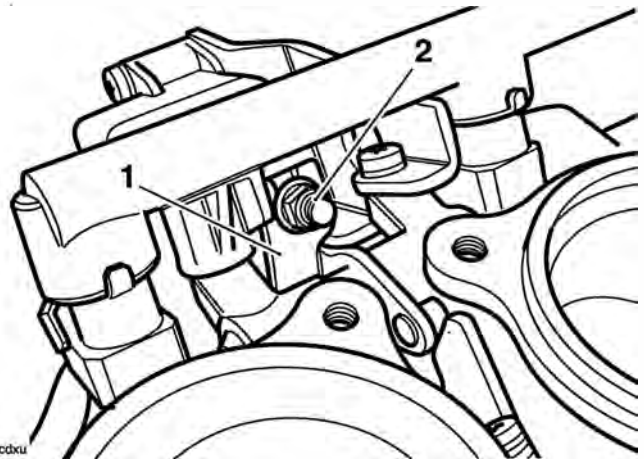

1. Idle speed control lever

2. Nut etc.

7. Remove the two screws securing the idle speed control stepper motor to its bracket, then remove the stepper motor in the direction shown.

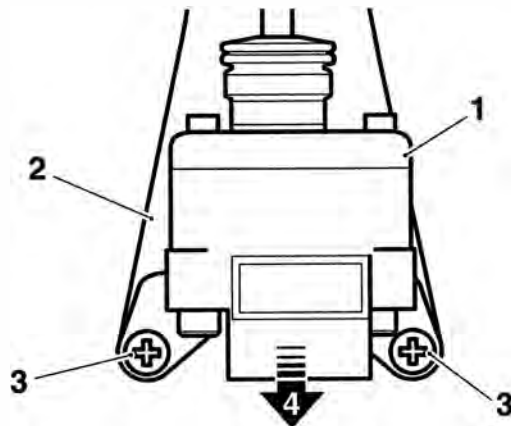

cdaw

1. Idle speed control stepper motor

2. Bracket

3. Fixings

4. Direction of removal

# Fuel System/Engine Management

- Leave the plastic collar and spring on the stepper motor arm.

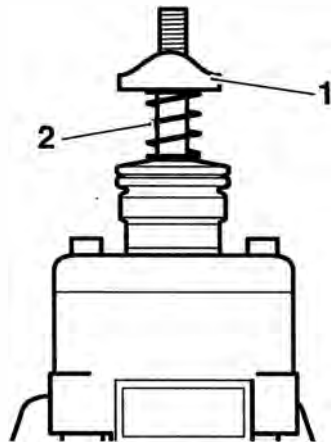

cdax

- Collar
- Spring

## Installation

- Ensure the Idle speed control lever is correctly positioned in relation to the throttle cam as shown below.

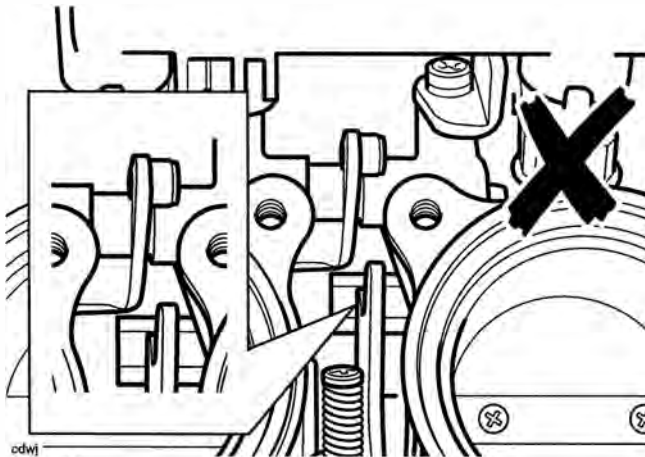

cdwj

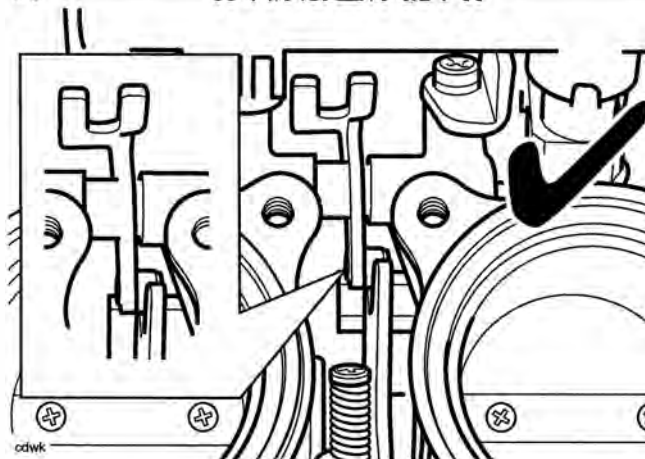

cdwk

- If removed, loosely fit the spring and collar on the stepper motor arm.

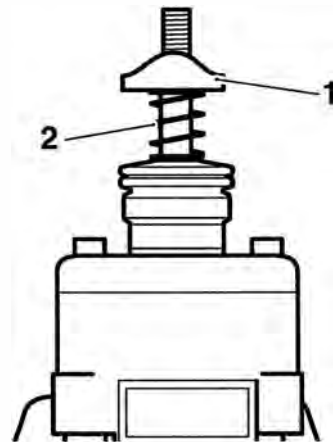

cdax

- Collar
- Spring

- Locate the stepper motor to its bracket and tighten the fixings to **3.5 Nm**.

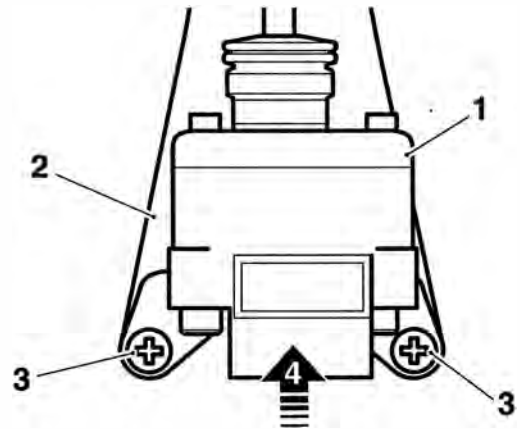

cdaxss

- Idle speed control stepper motor
- Bracket
- Fixings
- Direction of fitting

- Fit the plastic washer to the lever then fit the metal washer and nut.

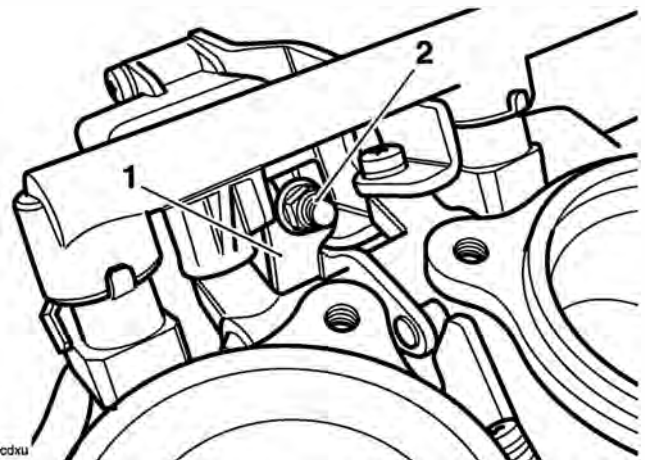

cdxlu

- Idle speed control lever
- Nut etc.

5. Mount the throttle body onto the engine.
6. Temporarily reconnect the battery, positive (red) lead first.
7. Attach the Triumph diagnostic tool to the dedicated plug, refer to the Triumph Diagnostic Tool User Guide.
8. Turn the ignition to the 'ON' position.
9. On the diagnostic tool navigate to 'Engine Diagnostics' and select the 'Adjust Tune' button.
10. Select 'Idle Speed Control Stepper Renew' then press the 'Adjust' button.
11. On pressing the 'Adjust' key, the diagnostic tool will send a command that drives the throttle to the fully closed position. The tool will also display the voltage reading coming from the throttle position sensor which should be between the target voltage range of 0.58V and 0.62V.

## Adjust Tune Procedure

Adjust the throttle position sensor as described in the service manual until the voltage reading is within the range shown below  
 Press OK when the adjustment is complete  
 Press cancel to cancel the adjustment process

Throttle Voltage:	0.59 V
Target Voltage Range:	0.58 V - 0.62 V

 Adjusting parameter - Throttle Position Sensor Adjust

## Adjust Tune Screen

12. Tighten the stepper arm nut on the idle speed stepper motor until a clearance of 0.5 mm can be measured between the idle speed control cam and the throttle roller.

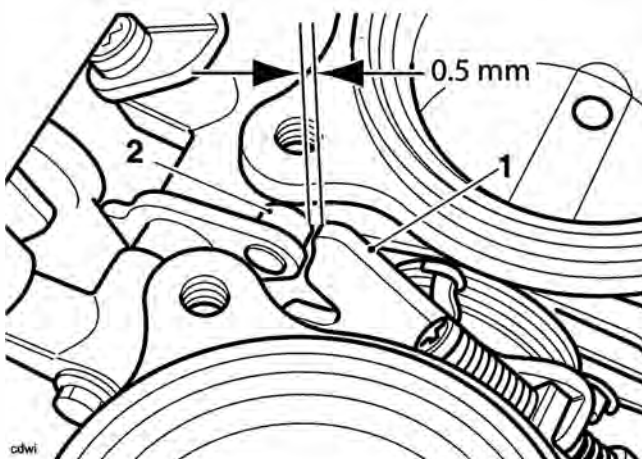

1. Idle speed control lever
2. Throttle roller

13. Check the voltage reading shown on the software. If the reading is between the target voltage range, then proceed to step 17. If the reading is not within this range, adjustment must be made as described in steps 14 to 16.
14. Slacken the screws on the throttle position sensor.
15. Gently turn the throttle position sensor until the voltage reading shown on the software is between the target voltage range.
16. Tighten the sensor retaining screws to **2 Nm** and recheck the voltage reading shown on the software. Repeat the adjustment if the reading is outside the specified range.
17. Click the 'OK' button to progress to the next adjustment.

## Note:

- **The diagnostic software will calculate the target voltage range for when the throttle is in the fully open position.**
18. On pressing the 'OK' button, the diagnostic tool will send a command that drives the throttle to the fully open position. The tool will also display the voltage reading coming from the throttle position sensor which should be between the target voltage range calculated by the software and shown on the screen.
  19. With the stepper fully opened, check the voltage shown on the software and, if necessary, adjust the nut on the top of the stepper arm until the software shows a voltage within the target voltage range shown on the screen. The reading on the screen will change from red to green, indicating that the reading is correct.

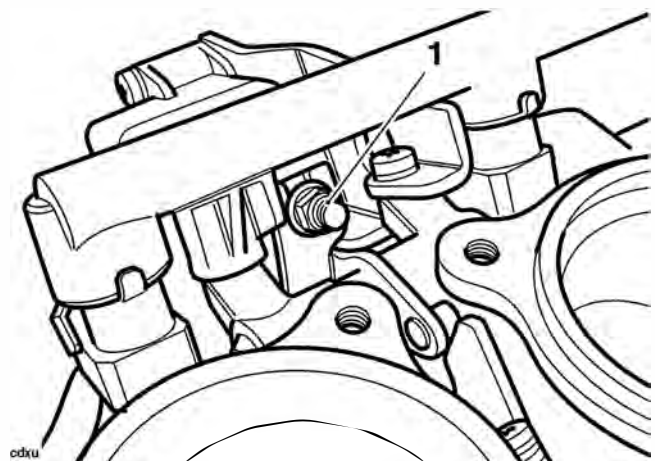

1. Adjustment nut

- Click the 'OK' button to fully close the idle speed control stepper motor. After a minimum of 15 seconds (the tool will show 'Adapting' and not allow further actions to take place during this period), click the 'OK' button again to return the ECM to normal control.



## Caution

Do not operate the throttle while the stepper motor is being adjusted, otherwise the incorrect value will be adapted and the engine will not start.

- Turn the ignition to the 'OFF' position.
- Disconnect the diagnostic tool.
- Disconnect the battery, negative (black) lead first.
- Check and adjust the throttle cable settings (see page 10-104).



## Warning

Move the handlebars to left and right full lock while checking that the cables and harnesses do not bind. A cable or harness which binds will restrict the steering and may cause loss of control and an accident.

- Refit the airbox (see page 10-101).
- Refit the fuel tank (see page 10-92).
- Reconnect the battery, positive (red) lead first.
- Refit the rider's seat (see page 16-13).

## Engine Management Adaption

### General Information

The engine management system fitted to this model is adaptive. This means that the system is able to learn about new or changing operating conditions and continuously adapt itself without needing to constantly make major adjustments from a fixed baseline setting.

Adaptive changes can become necessary because of changing rider behaviour, changes in the region in which the bike is operated (i.e. operation at high altitude where it was previously used at sea level) or because a new part may have been fitted which has slightly different characteristics to the old part. All adaptive changes are automatic and require no intervention by rider or dealer.

### Adaption Status

To see if a motorcycle has fully adapted, a facility named 'ADAPTION STATUS' is provided on the diagnostic software. The following adaption details can be examined:

Function Examined	Report Method
Closed throttle position reference status	adapted/not adapted
Idle speed control adaption status	%
Oxygen sensor adaption status (off idle)	%
Oxygen sensor adaption range (off idle)	%
Oxygen sensor adaption status (idle)	%
Oxygen sensor adaption range (idle)	%

### Terminology

Where the term 'status' is used, this indicates how far the present operating parameter is from the stored (baseline) value. The nearer these figures are to zero the better as it indicates the motorcycle has adapted to its current operating conditions.

The term 'range' indicates how much (in percentage terms) of the adjustment range has been used to reach the current operating status.

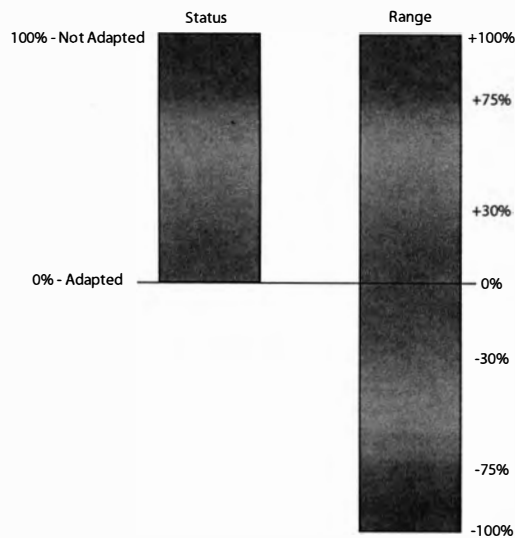

## Typical Values

In a correctly adapted motorcycle, the following will be typical:

Function Examined	Read Out
Closed throttle position reference status	Yes (Adapted)
Idle speed control adaption status	Between +100 and -100%
Oxygen sensor adaption status (off idle)	0% +/- 10%
Oxygen sensor adaption range (off idle)	Between +100 and -100%
Oxygen sensor adaption status (idle)	0% +/- 10%
Oxygen sensor adaption range (idle)	Between +100 and -100%

## Forcing adaption to take place

If the read out indicates that the motorcycle is not adapted, the following will force the system to make adaptations:

**Warning**

Never start the engine or let it run for any length of time in a closed area. The exhaust fumes are poisonous and may cause loss of consciousness and death within a short time. Always operate the motorcycle in the open air or in an area with adequate ventilation.

1. Ensure the engine is cold.
2. **WITHOUT TOUCHING THE THROTTLE**, start the engine and allow it to warm up until the cooling fan comes on.
3. Leave the engine to idle for a further 12 minutes.

### Note:

- **As an alternative to the above process, connect the diagnostic tool, select ADJUST TUNE (see the Triumph Diagnostic Tool User Guide) and select RESET ADAPTIONS. This will force a fast adaption routine to take place in around 5 seconds. For this to happen, the engine MUST be running, it must be at normal operating temperature and in closed loop control mode. Under any other conditions fast adaption will not take place and may cause default values to be loaded, which may then require a normal 12 minute adaption routine to be run.**

## Fault Indications

If 'range' figures at 100% are seen, then the adjustment has reached maximum indicating a mechanical fault exists on the motorcycle. This can be due to a number of faults but the most likely causes will be low/high fuel pressure, faulty injectors or air leaks at the throttle bodies or airbox.

In these circumstances, locate and rectify the fault, and reset the adaptations as described above.

## Exhaust System

### Removal

#### **Warning**

If the engine has recently been running, the exhaust system will be hot. Before working on or near the exhaust system, allow sufficient time for the exhaust system to cool as touching any part of a hot exhaust system could cause burn injuries.

1. Remove the rider's seat (see page 16-13).
2. Disconnect the battery, negative (black) lead first.
3. Release the clamp securing the silencer to the header pipe.

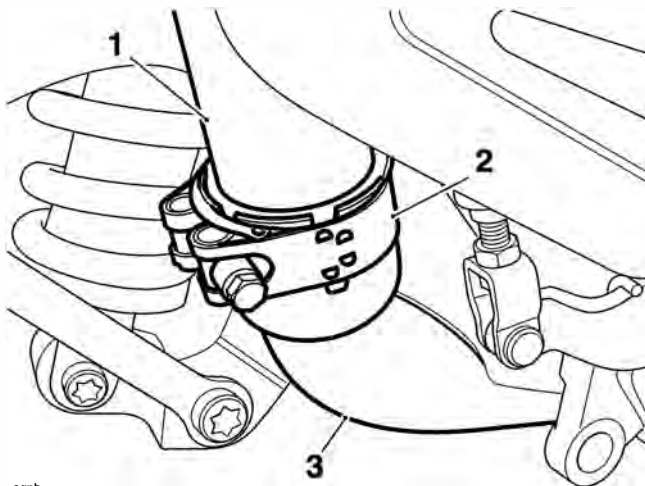

cgph

1. Silencer
2. Clamp
3. Header pipe

4. Support the right hand silencer and release the bolt and nut securing the silencer mounting bracket to the rear frame.

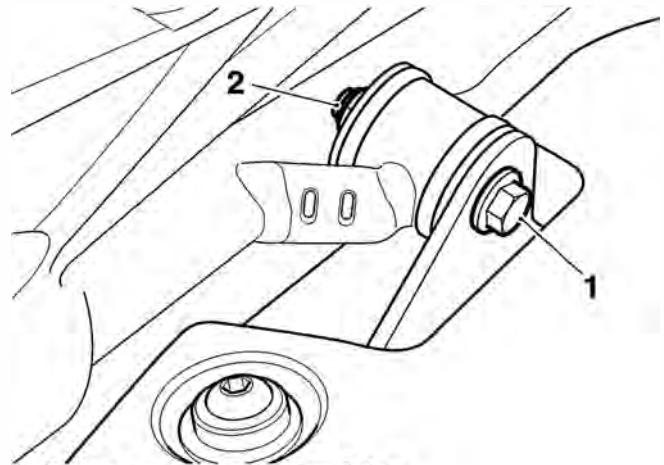

1. Silencer mounting bracket fixing
2. Nut

5. Move the silencer rearwards to disengage it from the header pipe and remove.
6. Remove the sump guard (see page 16-24).
7. Disconnect the oxygen sensor from the main harness.
8. Remove the radiator (see page 11-11).
9. Release the fixings securing the header pipe joints to the cylinder head. Discard the fixings.

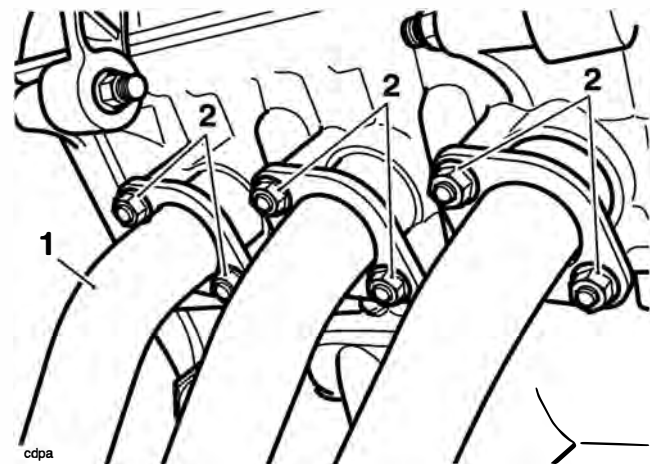

- cdpa
1. Header pipes
  2. Fixings



10. Remove the bolt from the header pipe rear mounting point.

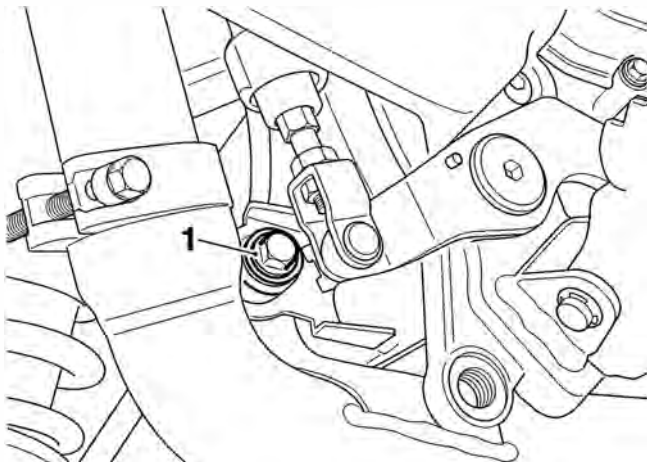

### 1. Header pipe rear mounting bolt

11. Detach the header pipe assembly and collect the seals from the cylinder head ports.
12. If necessary, remove the oxygen sensor.

### Assembly

1. If removed, install the oxygen sensor and tighten to **25 Nm**.
2. Fit new seals to the cylinder head. Ensure that the face of the seal with the tab is facing the cylinder head.

### Note:

- A smear of grease may be used to retain the seals in the cylinder head during assembly.

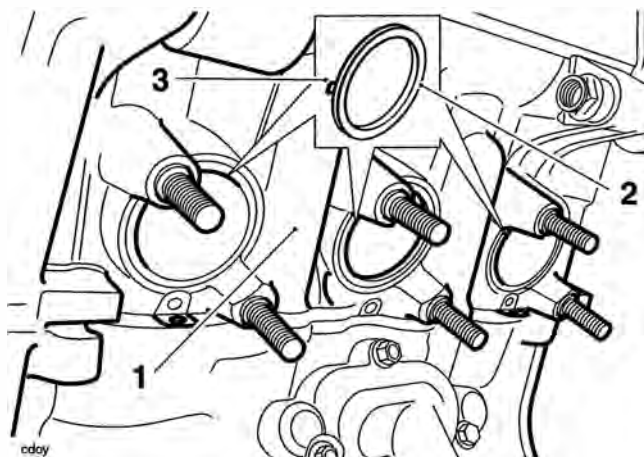

### 1. Cylinder head

### 2. Seal

### 3. Seal tab

3. Locate the header pipes and align the header pipe flanges to the fixing points. Fit new nuts and hand tighten.
4. Assemble the rear mounting point fixing but do not tighten at this stage.

# Fuel System/Engine Management

5. Tighten the header pipe to cylinder head nuts in the sequence shown below:

- **Stage 1:** Tighten the header pipe nuts to **2 Nm**.
- **Stage 2:** Tighten the header pipe nuts to **19 Nm**.

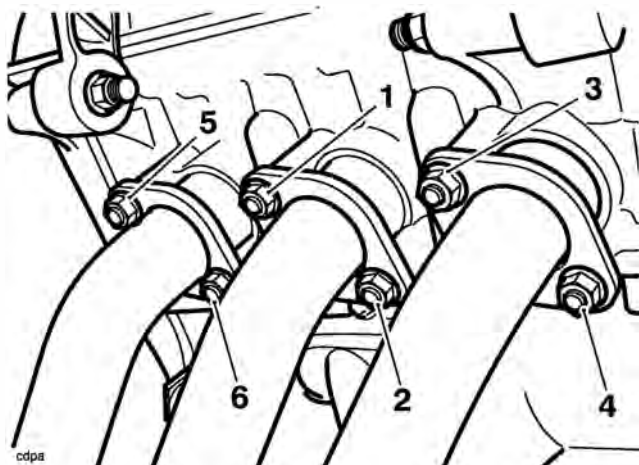

**Header Pipe Tightening Sequence**

6. Tighten the rear mounting point fixing to **19 Nm**.
7. Refit the radiator and refill the cooling system (see page 11-12).
8. Reconnect the oxygen sensor and route the harness under the sump guard as noted on disassembly.
9. Refit the sump guard (see page 16-21).
10. Position and engage the silencer to the header pipe. Do not tighten the clamp at this stage.

11. Align the silencer mounting bracket to the rear frame bracket. Refit the nut. Tighten the fixings to **15 Nm**.

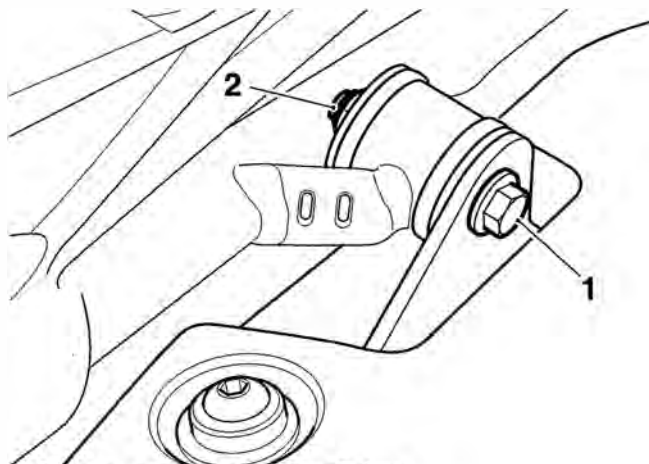

1. Silencer mounting bracket fixing
2. Nut

12. Align the clamp for the silencer to header pipe joint as shown below and tighten to **10 Nm**.

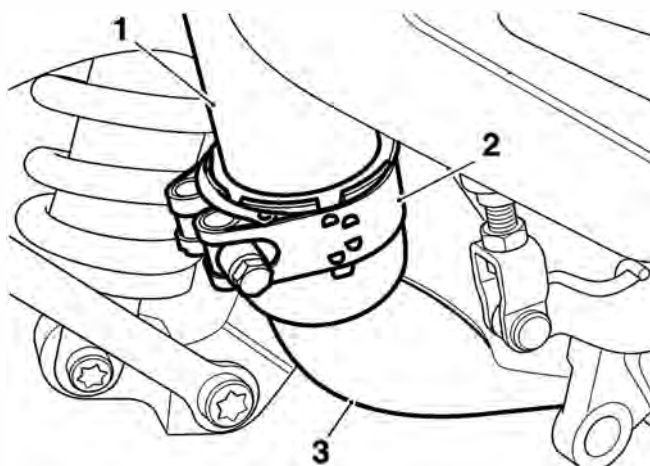

1. Silencer intermediate pipe
2. Clamp
3. Header pipe

13. Reconnect the battery, positive (red) lead first.



## Caution

Do not install the exhaust system or run the engine without the exhaust heatshields fitted. Components protected by the exhaust heatshields may suffer severe damage or a fire if the motorcycle is operated without the heatshields being fitted.

14. Start the engine and check for exhaust gas leaks. Rectify if necessary.
15. Refit the rider's seat (see page 16-13).

## Evaporative Emissions Control System

### California Models Only

All California models are fitted with a system to control the evaporation of fuel vapour to the atmosphere.

A carbon filled canister absorbs vapour while the engine is not running. When the engine is started, the vapour is returned to the engine and burnt.

There are two distinct phases to the system's operation, engine off and engine running. These two conditions are explained overleaf.

### Component Locations

**Carbon Filled Canister** (2) - below the swinging arm.

**Purge Control Valve** (3)- adjacent to frame, left hand side (electronically controlled by the ECM).

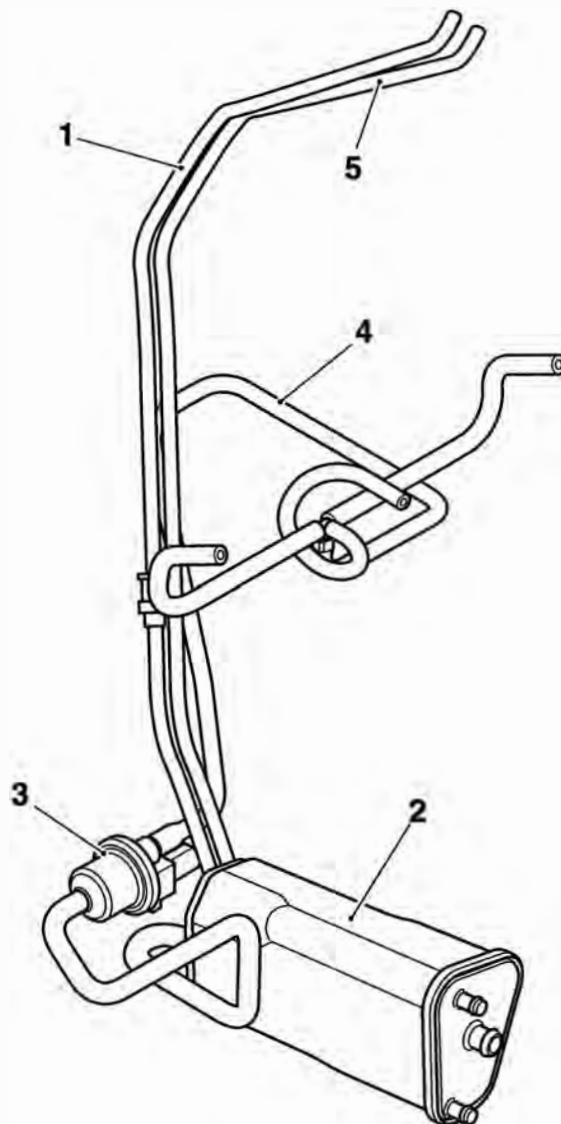

1. Breather hoses
2. Carbon filled canister
3. Purge valve
4. Purge hose to throttle bodies
5. Fuel tank filler drain

# Fuel System/Engine Management

---

## Evaporative Control System - Engine Off

When the engine is stationary any pressure increase in the fuel tank due to a rise in ambient temperature will cause the fuel vapour to pass down the breather hose (1) to a carbon filled canister (2) which stores the vapour.

Once in the canister, vapour cannot enter the engine because the purge valve is closed.

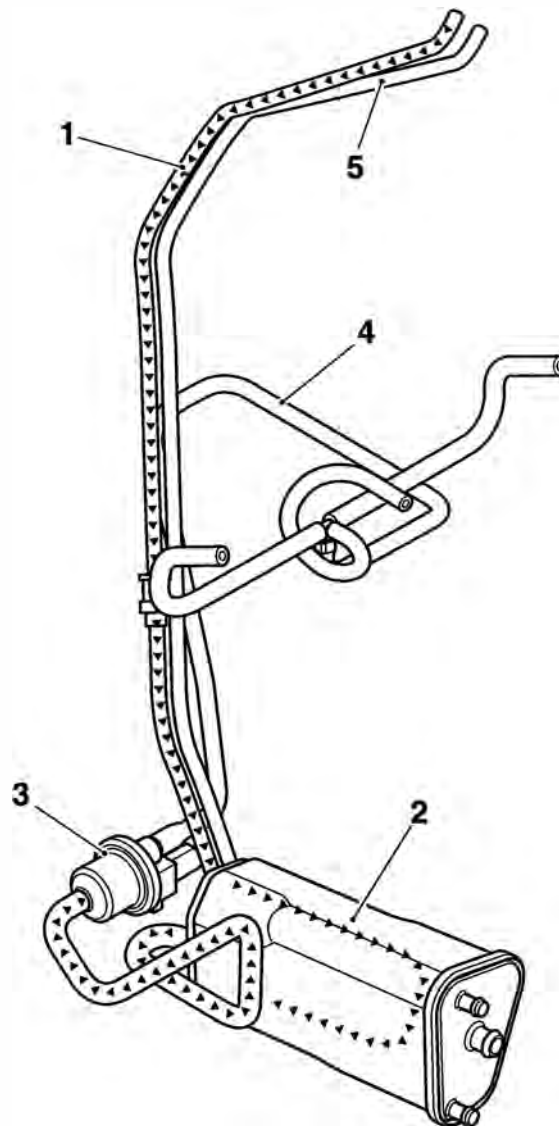

- 1. Breather hoses
- 2. Carbon filled canister
- 3. Purge valve (closed)
- 4. Purge hose to throttle bodies
- 5. Fuel tank filler drain

## Evaporative Control System - Engine Running

When the engine is running, engine vacuum is applied to the purge hose (4) from the throttle bodies.

At certain times, the ECM opens the purge valve. The vacuum applied to the purge hose (4) now begins to draw stored vapour from the carbon filled area of the canister and returns it to the throttle bodies for burning in the engine.

In order to control the speed at which vapour is purged from the canister, the engine management system shuttles the purge control valve between open and closed positions.

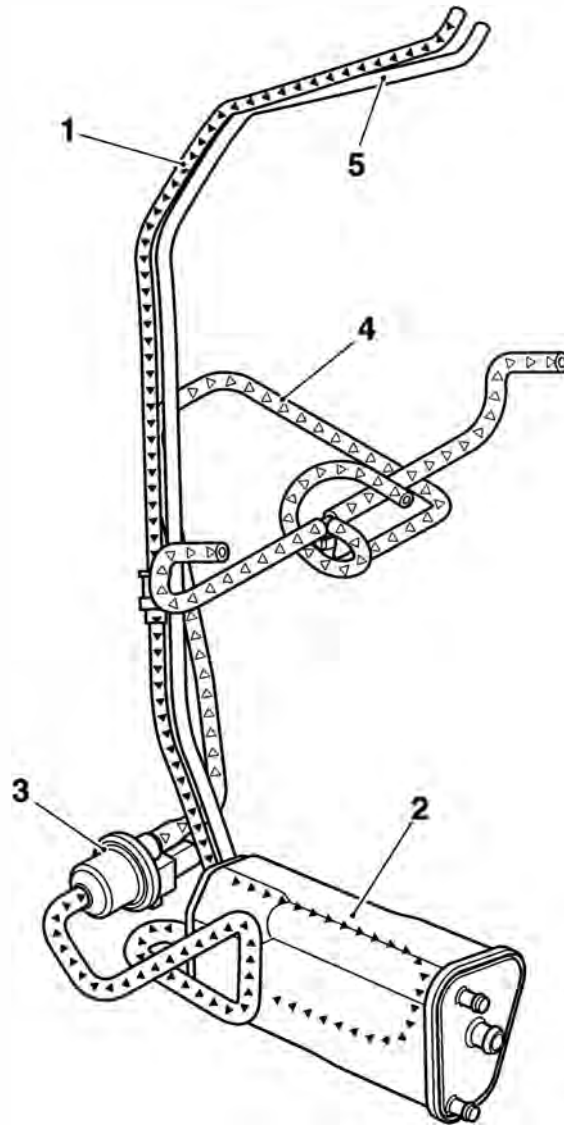

1. Breather hoses
2. Carbon filled canister
3. Purge valve (open under ECM control)
4. Purge hose to throttle bodies
5. Fuel tank filler drain

This page intentionally left blank

# 11 Cooling

## Table of Contents

Exploded View - Cooling System .....	11.2
Coolant .....	11.3
Radiator Hoses .....	11.4
Radiator and Cooling Fan .....	11.4
Coolant Level Inspection .....	11.4
Coolant Replacement .....	11.5
Drainage .....	11.5
Filling .....	11.5
Water Pump .....	11.7
Coolant Pressure Cap and Coolant System .....	11.7
Inspection and Testing .....	11.7
Thermostat .....	11.9
Removal .....	11.9
Inspection .....	11.10
Installation .....	11.10
Radiator .....	11.11
Removal .....	11.11
Inspection .....	11.12
Installation .....	11.12

# Cooling

## Exploded View - Cooling System

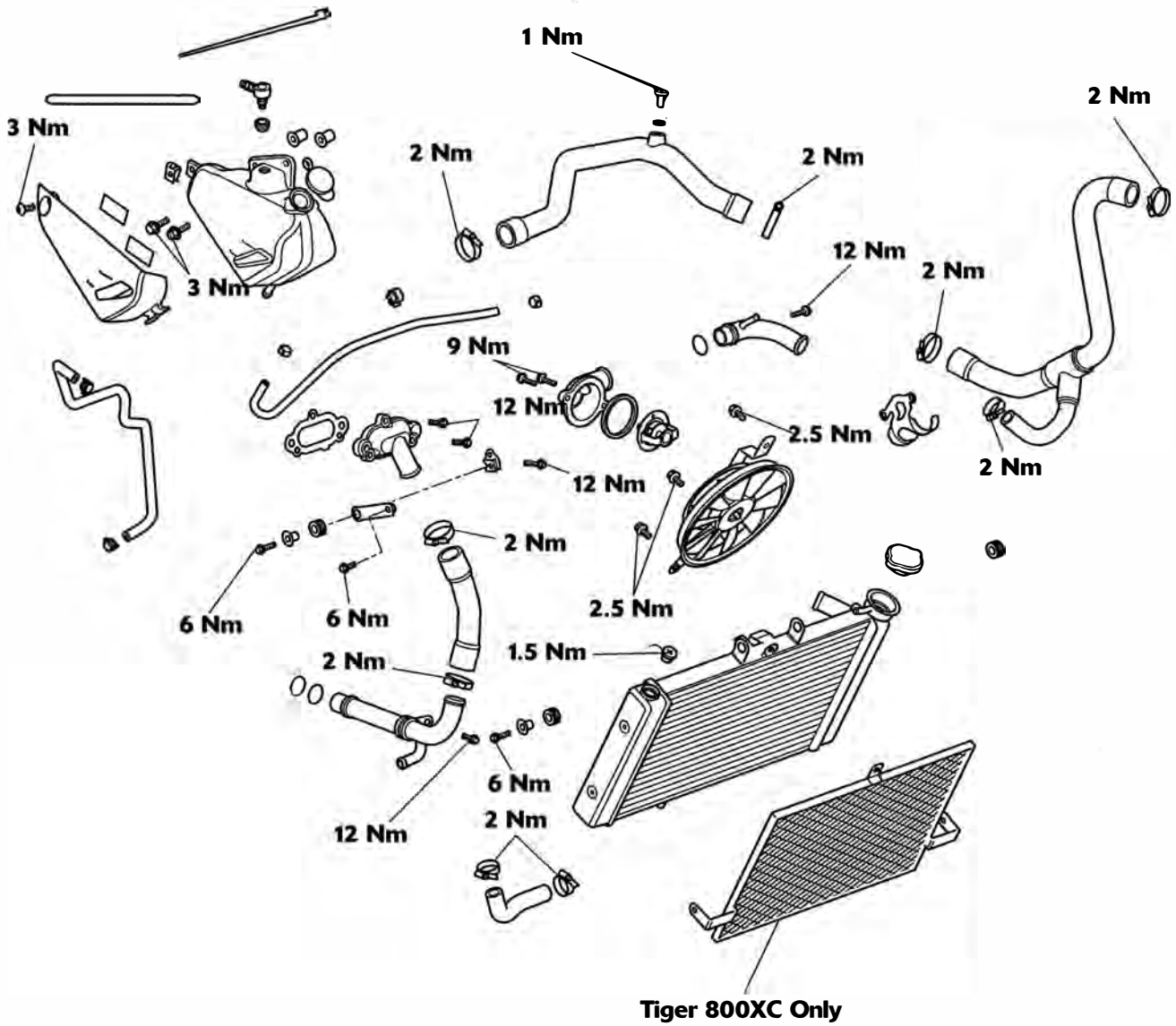



## Coolant

A permanent type of anti-freeze is installed in the cooling system when the motorcycle leaves the factory.

A year-round, Hybrid Organic Acid Technology (known as Hybrid OAT or HOAT) coolant is installed in the cooling system. It is coloured green, contains a 50% solution of ethylene glycol based antifreeze, and has a freezing point of -35°C (-31°F).

### Note:

- HD4X Hybrid OAT coolant, as supplied by Triumph, is pre-mixed and does not need to be diluted prior to filling or topping up the cooling system.

### All models

Always change the coolant at the intervals specified in the scheduled maintenance chart.



### Warning

The coolant mixture contains anti-freeze and corrosion inhibitors, which both contain toxic chemicals which are harmful to the human body. Never swallow anti-freeze or any of the motorcycle coolant.



### Caution

The coolant mixture contains a corrosion inhibitor which helps prevent damage to the metal surfaces inside the cooling system. Without this inhibitor, the coolant would 'attack' the metals and the resulting corrosion would cause blockages in the cooling system leading to engine overheating and damage. Always use the correct anti-freeze as specified in the owner's handbook. Never use a methanol based anti-freeze as this does not contain the required corrosion inhibition properties.



### Caution

Distilled water must be used with the anti-freeze (see specification for anti-freeze) in the cooling system. If hard water is used in the system, it causes scale accumulation in the water passages, and considerably reduces the efficiency of the cooling system. Reduced cooling system efficiency may cause the engine to overheat and suffer severe damage.

# Cooling

## Radiator Hoses

Regularly check all radiator hoses and hose clips for cracks, leaks or deterioration in accordance with the scheduled maintenance chart.

## Radiator and Cooling Fan

Check the radiator fins for obstruction by insects, mud, leaves and general debris. Clean off any obstructions by hand or with a stream of low pressure water.

### Warning

The cooling fan operates automatically. To prevent injury, keep hands and clothing away from the fan blades at all times.

### Caution

Using high-pressure water sprays can damage the radiator fins and impair the radiator's efficiency.

Do not obstruct or deflect airflow through the radiator by installing unauthorized accessories in front of the radiator or behind the cooling fan. Interference with the radiator airflow can lead to overheating and consequent engine damage.

## Coolant Level Inspection

### Warning

Do not remove the coolant pressure cap when the engine is hot. When the engine is hot, the coolant inside the radiator is hot and also under pressure. Contact with the pressurised coolant will cause scalds and skin damage.

#### Note:

- **Only inspect the coolant level when the engine is cold.**

1. Position the motorcycle on level ground and in an upright position.
2. The expansion tank can be viewed from the right hand side of the motorcycle, below and towards the front of the fuel tank. The coolant level should be between the 'MAX' and 'MIN.' marks.

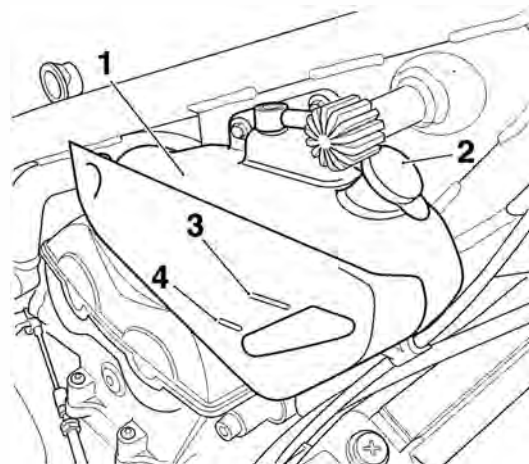

1. **Expansion tank (fuel tank shown removed for clarity)**

2. **Expansion tank filler cap**

3. **'MAX' mark**

4. **'MIN.' mark**

3. If the level of coolant is low, remove the cap from the expansion tank and add coolant mixture as necessary to bring the level up to the 'MAX' mark. Refit the cap.

### Caution

If the coolant level is found to be low, or if coolant has to be added regularly, inspect the cooling system for coolant leaks. If necessary, pressure test the system to locate the source of the leak and rectify as necessary. Loss of coolant may cause the engine to overheat and suffer severe damage.

## Coolant Replacement

### Drainage

#### Note:

- Prior to disassembly of the coolant hoses, note the orientation and position of the hose clips to help ensure that they are returned to the same positions and orientation on assembly.
- Early models have a bleed screw fitted to the radiator top hose. The bleed screw was removed shortly after the start of production and a straight hose (without a bleed screw) was introduced. As a result, the bleed procedure is slightly different depending on the type of top hose fitted.

1. **Models with a top hose bleed screw:** Position the motorcycle on level ground on the sidestand.
2. **Models without a top hose bleed screw:** Position the motorcycle on level ground a paddock stand.
3. Remove the rider's seat (see page 16-13).
4. Disconnect the battery, negative (black) lead first.

### Warning

Do not remove the coolant pressure cap when the engine is hot. When the engine is hot, the coolant inside the radiator is hot and also under pressure. Contact with the pressurised coolant will cause scalds and skin damage.

5. Remove the lower radiator panels (see page 16-14).
6. Remove the upper radiator panels (see page 16-14).
7. Remove the coolant pressure cap on the radiator.

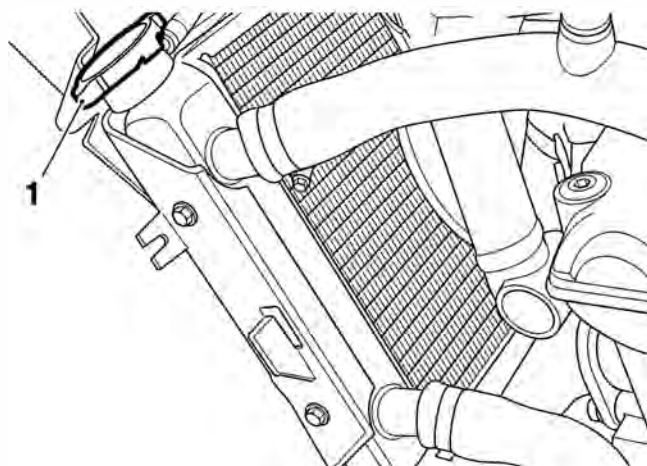

1. Radiator Cap

8. Position a container to collect the displaced coolant.

9. Slacken the clip then release the bottom hose from the radiator and allow the coolant to drain.

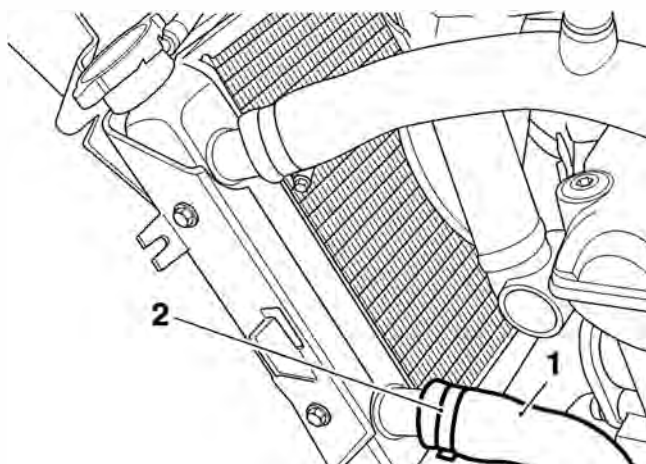

1. Bottom hose

2. Clip

10. Slacken the dip then release the heat exchanger hose from the heat exchanger and allow the coolant to drain.

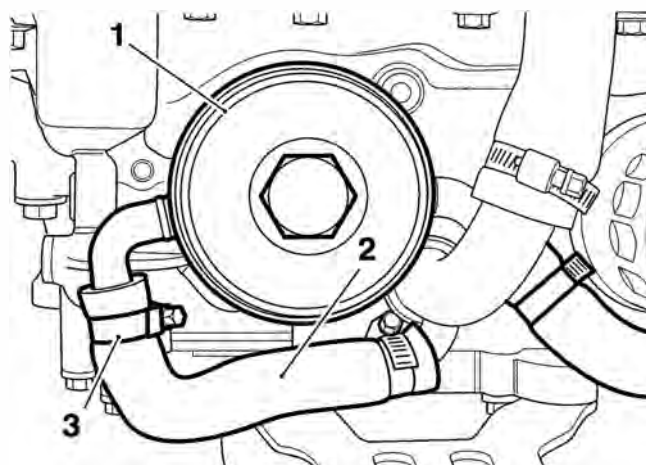

1. Heat exchanger

2. Heat exchanger hose

3. Coolant hose clips

### Filling

1. Reconnect the bottom hose and tighten the hose clip to **2 Nm**.
2. Reconnect the heat exchanger hose and tighten the hose clip to **2 Nm**.

# Cooling

- Remove the bleed screw from the right hand side of the radiator.

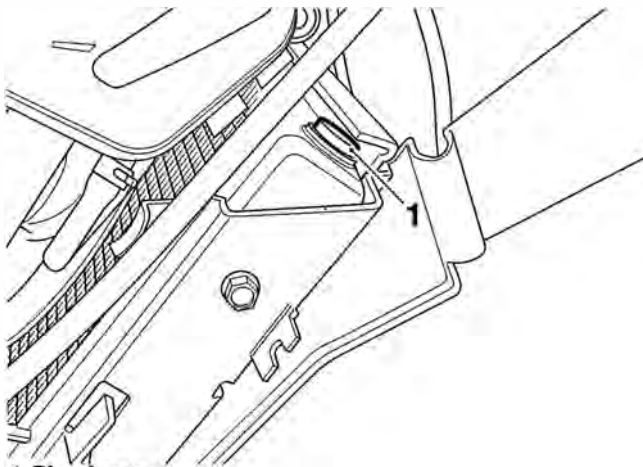

1. Bleed screw

- If fitted, remove the bleed screw from the top hose.

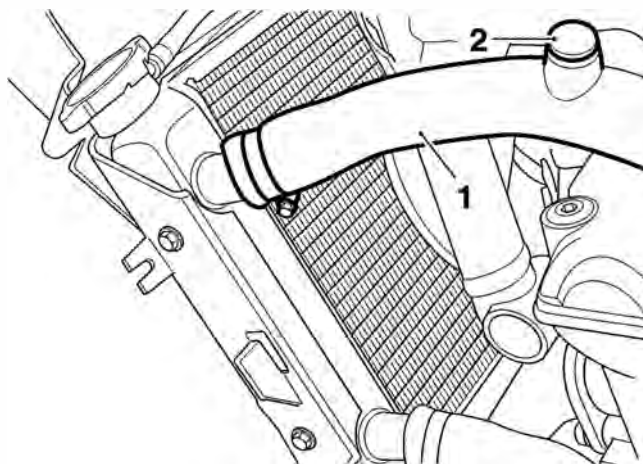

1. Top hose

2. Bleed screw (if fitted)

## Note:

- During filling, squeezing the bottom hose with both hands will help to pump coolant around the system and remove trapped air.

- Slowly add coolant mixture to the system, through the filler opening in the radiator, until the system is full.
- If the system has filled correctly and fully, there should be coolant visible through the:
  - radiator bleed screw opening;
  - top hose bleed screw opening (if fitted);
  - radiator filler opening.
- If there is no coolant visible through the radiator bleed screw opening, but the filler side appears to be full, attach a length of clear tubing to the radiator bleed screw spigot and syphon coolant into the bleed screw side of the radiator.

## Note:

- A hand operated vacuum pump or similar should be used to syphon the coolant through the system.
- If necessary, top up the system through the filler and refit the pressure cap.
  - Install the radiator bleed screw and tighten to **1.5 Nm**.
  - If fitted, install the top hose bleed screw and tighten to **1 Nm**.
  - With the aid of an assistant, lean the motorcycle fully over to the right hand side, and then the left hand side, to release air trapped in the cooling system. Repeat as necessary.
  - Reconnect the battery, positive (red) lead first.
  - Start the motorcycle and allow to run for approximately 20 to 30 seconds. Briefly raise the engine speed several times to allow any air to be expelled from the system.
  - Stop the engine. Check and top up the coolant level as necessary.
  - With the aid of an assistant, lean the motorcycle fully over to the right hand side, and then the left hand side, to release air trapped in the cooling system.
  - Start the motorcycle. Briefly raise the engine speed several times to allow any air to be expelled from the system.
  - Allow the engine to run until the cooling fan operates.
  - Stop the motorcycle and allow the engine to cool.



## Warning

Do not remove the coolant pressure cap when the engine is hot. When the engine is hot, the coolant inside the cooling system is hot and also under pressure. Contact with the pressurised coolant will cause scalds and skin damage.

- Check and top up the coolant level as necessary.
- Refit the upper radiator panels (see page 16-14).
- Refit the lower radiator panels (see page 16-14).
- Check the expansion tank level and top up if necessary.
- Refit the rider's seat (see page 16-13).

## Water Pump

### Note:

- The oil pump and water pump are supplied as an assembly and cannot be separated. For additional information, refer to **Oil Pump** (see page 8-8 for removal and page 8-13 for installation).

## Coolant Pressure Cap and Coolant System Testing

### Inspection and Testing



### Warning

Do not remove the coolant pressure cap when the engine is hot. When the engine is hot, the coolant inside the radiator is hot and also under pressure. Contact with the pressurised coolant will cause scalds and skin damage.

1. Allow the engine temperature to cool for at least 30 minutes.
2. Remove the coolant pressure cap.
3. Check the condition of the upper and lower seals of the coolant pressure cap.

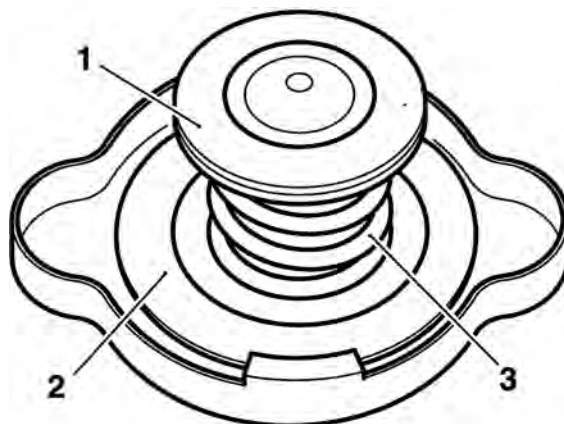

CAWR

1. Lower seal
2. Upper seal
3. Spring

### Note:

- If there is any sign of damage or deterioration replace the cap.
4. Pressure test the cap and cooling system to the blow off pressure of 1.1 bar as described below using T3880147. If the cap opens at a lower pressure or fails to open at 1.1 bar, replace the cap.

### Note:

- It is recommended to carry out coolant pressure cap and cooling system pressure tests consecutively.

# Cooling

## Coolant Pressure Cap Test

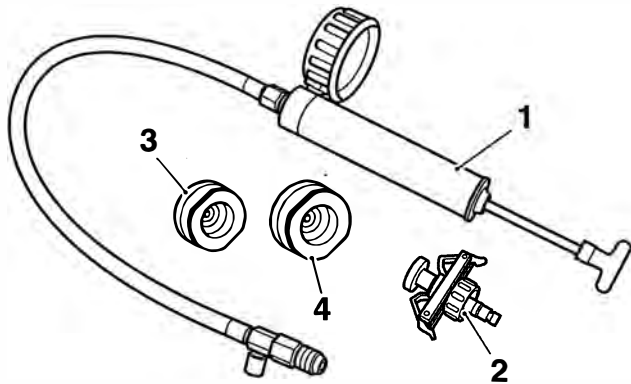

cgwp

1. Hand held pump
2. Bayonet type connector
3. Pressure cap test adaptor 44 mm
4. Pressure cap test adaptor 46 mm

1. Select the correct test adaptor and securely fasten to the pressure cap.
2. Carefully connect the hand pump to the adaptor ensuring an air tight seal is maintained.

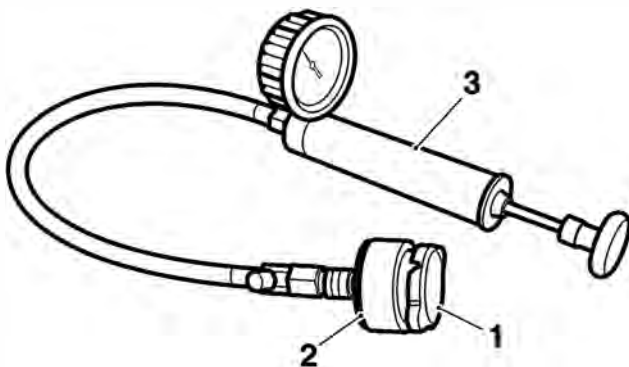

cgwq

1. Pressure cap
2. Test adaptor
3. Hand held pump

3. Pressure test the coolant cap to the blow off pressure. If the coolant cap opens at a lower pressure, fails to open at the correct pressure or the seal leaks, replace the cap.

## Coolant System Pressure Test

1. Select the bayonet type adaptor and securely fasten to the radiator.
2. Carefully connect the hand pump to the bayonet connector ensuring an air tight seal is maintained.

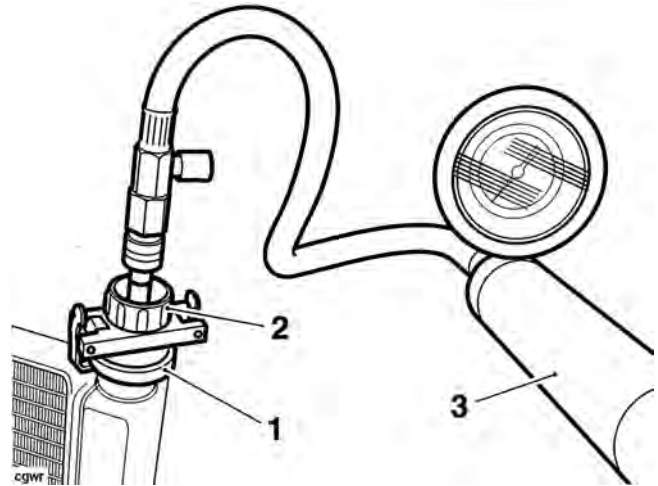

1. Radiator filler
2. Bayonet type connector
3. Hand held pump

3. Pressurise the cooling system to the operating pressure, using the hand pump taking care not to exceed the maximum cap pressure.
4. Hold the pressure for a minimum of 10 minutes, whilst visually inspecting the external components of the coolant system for leaks.
5. Remove the engine oil filler cap/dipstick and check for contamination of the engine oil caused by coolant escaping into the engine sump.

### Note:

- If the engine oil is contaminated further exploratory investigation will be required.
- If the engine oil is contaminated rectify the cause of the problem and then renew the oil and filter.

- Depressurise the coolant test kit using the pressure release valve.

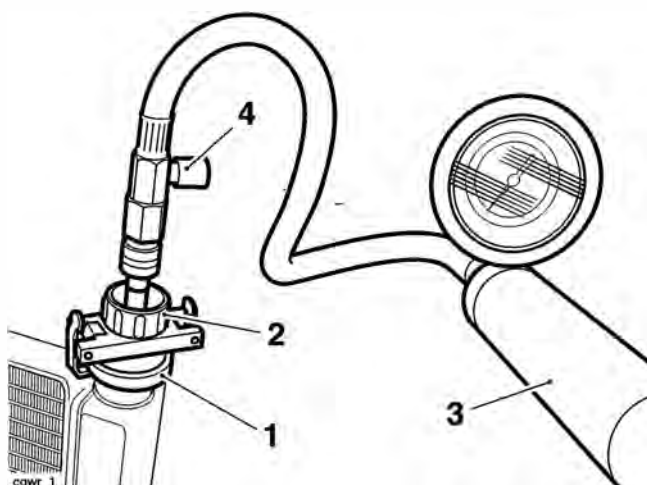

- Radiator filler
- Bayonet type connector
- Hand held pump
- Pressure release valve

- Refit the coolant cap.
- Fill the coolant to the maximum mark (see page 11-5).

## Thermostat

### Removal

#### Note:

- Prior to disassembly of the coolant hoses, note the orientation and position of the hose clips to help ensure that they are returned to the same positions and orientation on assembly.

- Remove the rider's seat (see page 16-13).
- Disconnect the battery, negative (black) lead first.
- Drain the coolant (see page 11-5).
- Remove the fuel tank (see page 10-91).
- Remove the airbox (see page 10-98).
- Remove the throttle bodies (see page 10-107).



### Warning

Do not remove the coolant pressure cap when the engine is hot. When the engine is hot, the coolant inside the radiator is hot and also under pressure. Contact with the pressurised coolant will cause scalds and skin damage.

- Detach the top hose from the thermostat elbow.
- Release the fixings securing the thermostat elbow to the cylinder head.
- Remove the thermostat housing.

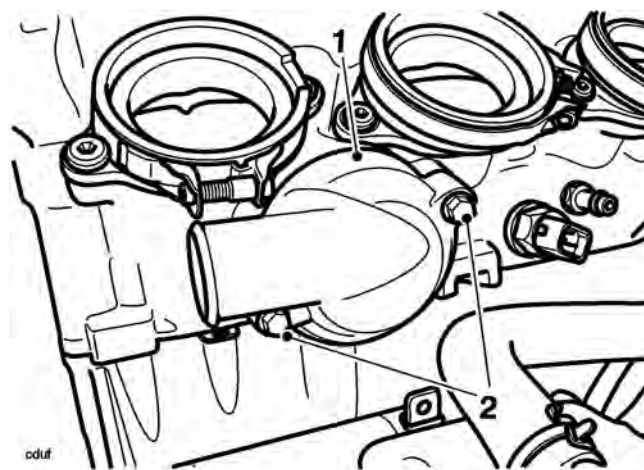

- Thermostat housing
- Fixings

## Cooling

10. Remove the thermostat from the cylinder head. Discard the seal.

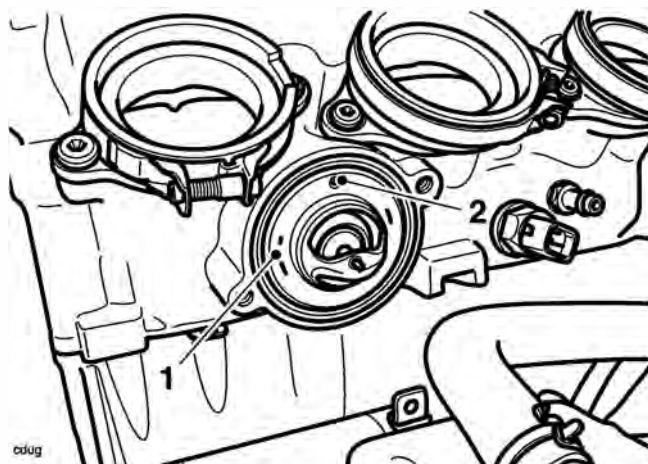

1. Thermostat
2. Bleed valve

3. Refit the thermostat housing and tighten the fixings to **9 Nm**.
4. Reconnect the top hose and tighten the clip. Tighten to **2 Nm**.
5. Refit the throttle bodies (see page 10-101).
6. Refit the airbox (see page 10-101).
7. Refit the fuel tank (see page 10-91).
8. Reconnect the battery positive (red) lead first.
9. Refit the rider's seat (see page 16-13).
10. Refill the cooling system (see page 11-5).

### Inspection

1. Inspect the thermostat at room temperature. If the valve is open, the thermostat must be replaced.
2. To check the valve opening temperature, suspend the thermostat in a container of water and raise the temperature of the water until the thermostat opens. The thermostat should start to open at  $71^{\circ}\text{C} \pm 5^{\circ}\text{C}$ .
3. If the temperature at which thermostat opening takes place is incorrect, replace the thermostat.

### Installation

1. Fit a new seal to the thermostat.
2. Locate the thermostat into the cylinder head. Ensure the bleed valve is uppermost as shown below.

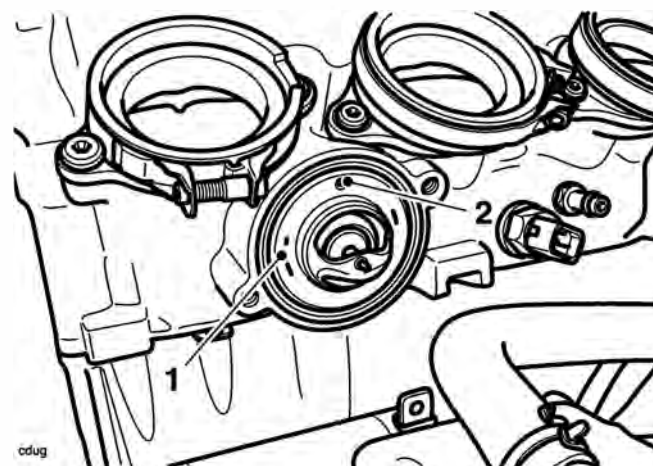

1. Thermostat
2. Bleed valve



## Radiator

### Removal

#### Note:

- Prior to disassembly of the coolant hoses, note the orientation and position of the hose clips to help ensure that they are returned to the same positions and orientation on assembly.

1. Remove the rider's seat (see page 16-13).
2. Disconnect the battery, negative (black) lead first.

### Warning

Do not remove the coolant pressure cap when the engine is hot. When the engine is hot, the coolant inside the radiator is hot and also under pressure. Contact with the pressurised coolant will cause scalds and skin damage.

3. Drain the coolant (see page 11-5).
4. Disconnect the top hose and expansion tank hose at the radiator.
5. Disconnect the bottom hose from the radiator.

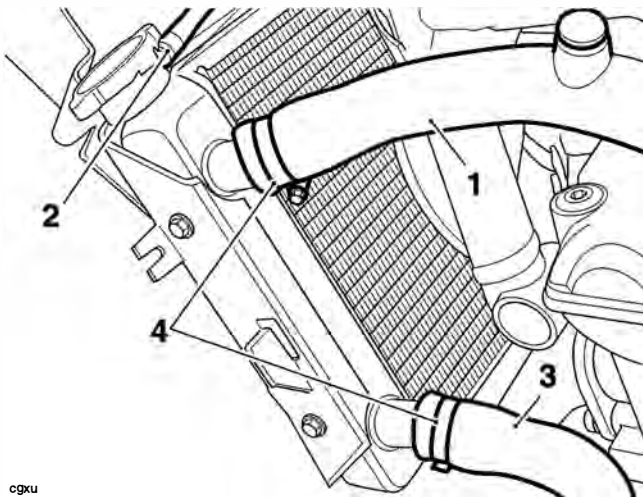

- cgxu
1. Top hose
  2. Expansion tank hose
  3. Bottom hose
  4. Clips

6. Release the radiator lower mounting.

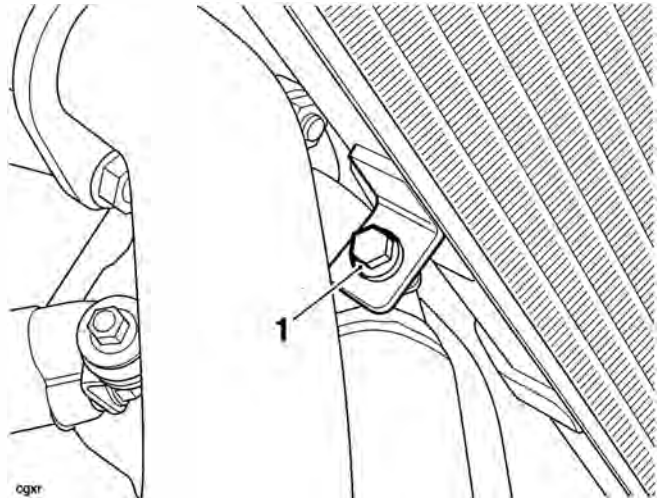

#### cgxr

### 1. Radiator lower mount fixing

7. Disconnect the cooling fan connection, located above the camshaft cover.
8. Detach the clutch cable from the radiator clip.
9. Release the fixing securing the radiator to the frame, and release the radiator grommet from the right hand mounting pin.

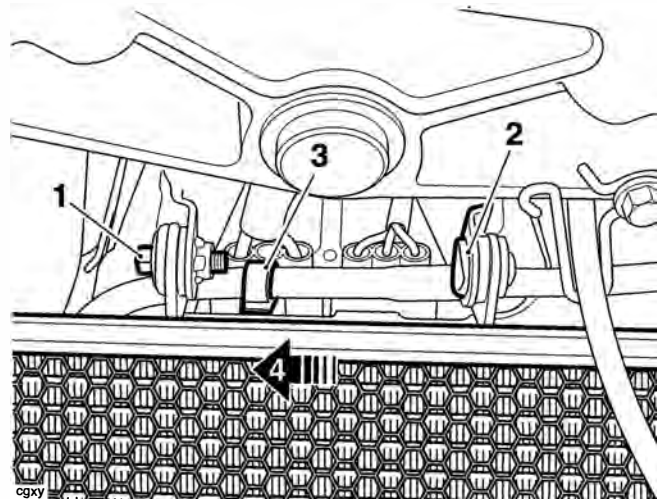

- cgxy
1. Radiator to frame fixing
  2. Radiator grommet
  3. Clutch cable clip
  4. Radiator removal direction

10. Remove the radiator.

# Cooling

---

## Inspection

1. Check the radiator for stone damage.
2. Check the radiator core for damage to the fins or obstructions to air flow.
3. Repair any damage and clear all obstructions.



### Caution

To avoid overheating and consequent engine damage, replace the radiator if the cores are blocked or if the fins are badly deformed or broken.

4. Check that the fan spins freely and without tight spots.
5. Check the fan blades for signs of heat distortion.

## Installation

1. Align the radiator grommet to the frame stud. Fit the upper mounting bolt and tighten the bolt to **6 Nm**.
2. Align the radiator lower mounting to the bracket on the engine. Fit and tighten the lower mounting bolt to **6 Nm**.
3. Reconnect the cooling fan.
4. Reconnect the expansion tank, and top and bottom hoses. Tighten the hose clips to **2 Nm**, ensuring they are repositioned as noted prior to disassembly.
5. Refill the cooling system (see page 11-5).
6. Reconnect the battery, positive (red) lead first.
7. Refit the rider's seat (see page 16-13).

# 12 Rear Suspension

## Table of Contents

Exploded View - Swinging Arm .....	12.2
Exploded View - Rear Hub and Wheel - Tiger 800.....	12.3
Exploded View - Rear Hub and Wheel - Tiger 800 XC .....	12.4
Exploded View - Rear Suspension Unit - Tiger 800 .....	12.5
Exploded View - Rear Suspension Unit - Tiger 800XC.....	12.6
Exploded View - Drop/Drag Link .....	12.7
Drive Chain .....	12.8
Chain Lubrication.....	12.8
Chain Adjustment.....	12.8
Chain Free-movement Inspection .....	12.8
Chain Free-movement adjustment .....	12.9
Chain Wear Inspection .....	12.9
Rear Suspension Unit .....	12.10
Removal .....	12.10
Inspection .....	12.11
Installation.....	12.11
Drag Link and Drop Links .....	12.12
Removal .....	12.12
Inspection .....	12.13
Installation.....	12.13
Swinging Arm .....	12.13
Removal .....	12.13
Inspection .....	12.14
Assembly.....	12.15
Drive Chain Replacement.....	12.15
Rivet link type .....	12.15

# Rear Suspension

## Exploded View - Swinging Arm

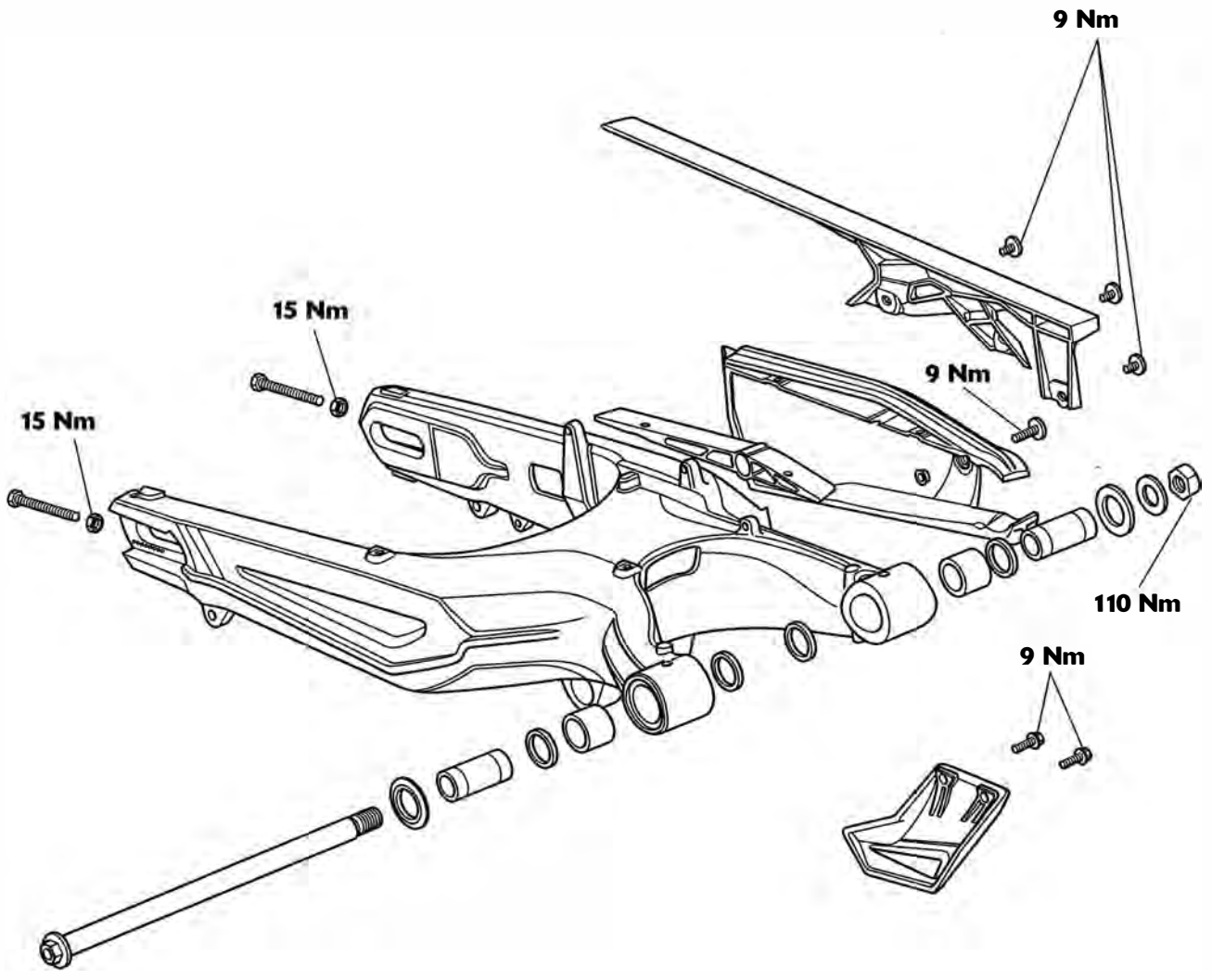

Exploded View - Rear Hub and Wheel - Tiger 800

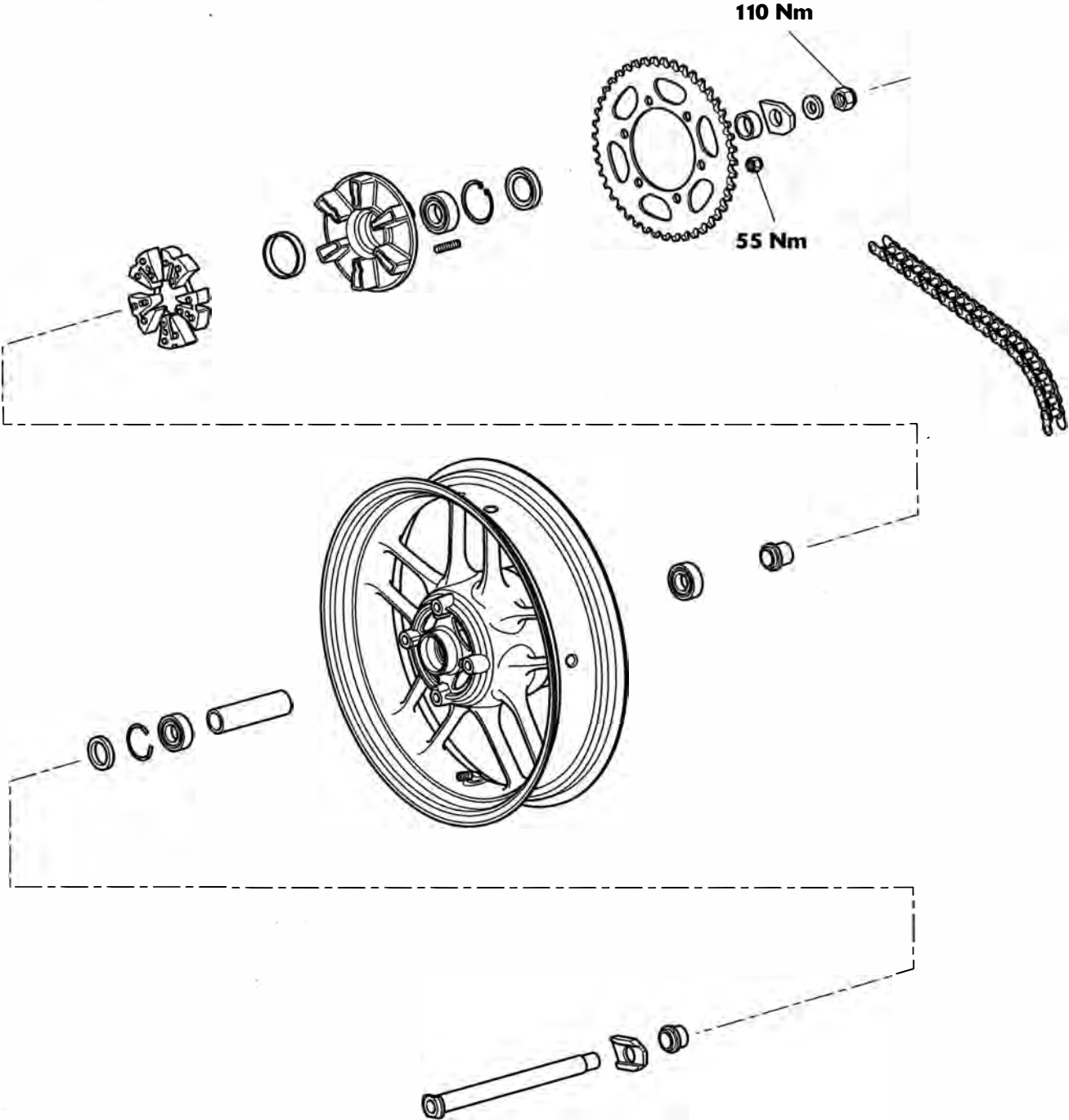

# Rear Suspension

## Exploded View - Rear Hub and Wheel - Tiger 800XC

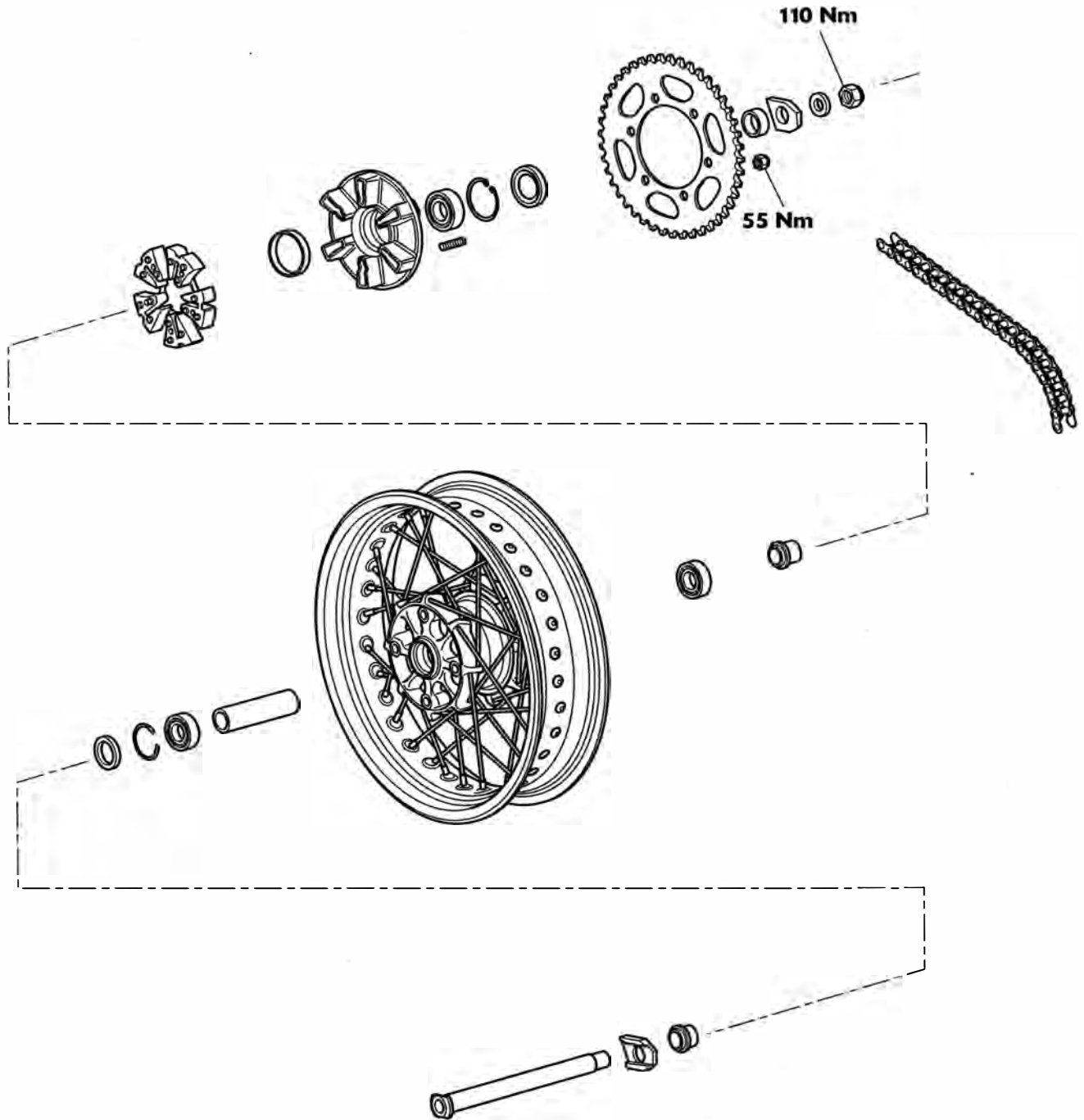

## Exploded View - Rear Suspension Unit - Tiger 800

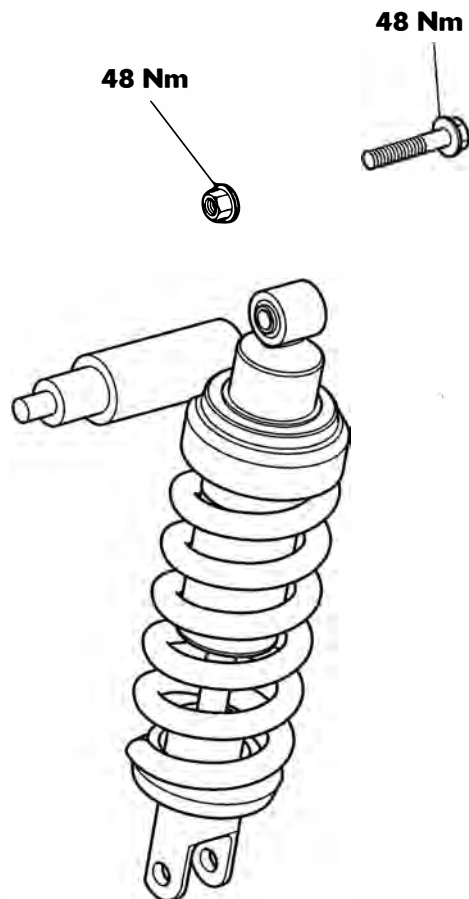

# Rear Suspension

---

## Exploded View - Rear Suspension Unit - Tiger 800XC

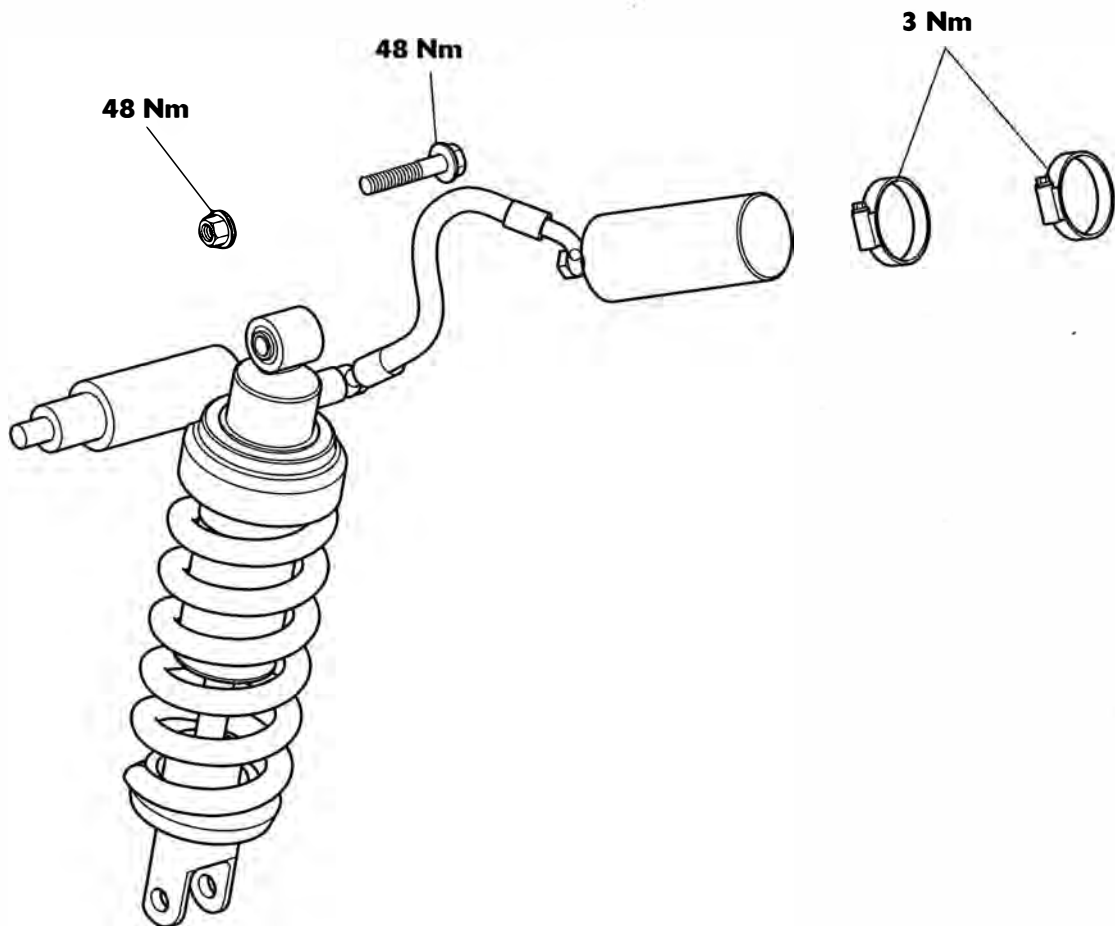



Exploded View - Drop/Drag Link

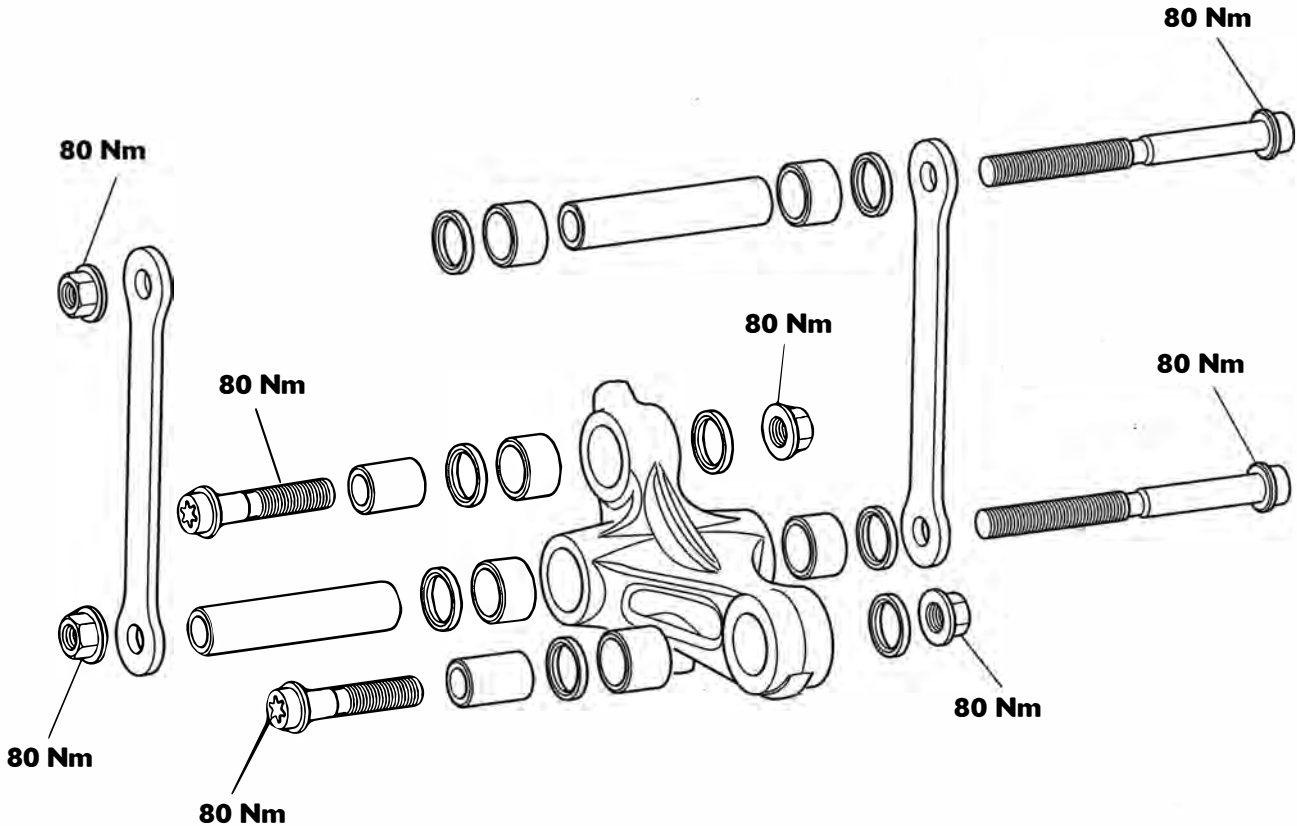

# Rear Suspension

## Drive Chain

For safety and to prevent excessive wear, the drive chain must be checked, adjusted and lubricated in accordance with scheduled maintenance requirements. Checking, adjustment and lubrication must be carried out more frequently for extreme conditions such as salty or heavily gritted roads.

If the chain is badly worn or incorrectly adjusted (either too loose or too tight) the chain could jump off the sprockets or break.

### Warning

A chain that breaks or jumps off the sprockets could snag on the engine sprocket or lock the rear wheel, severely damaging the motorcycle and causing an accident. Never neglect chain maintenance.

#### Note:

- **Lubrication of the drive chain should ideally be carried out with the motorcycle set up so that the rear suspension hangs free.**
- **The chain must be adjusted with the motorcycle in an upright position, resting on its wheels, and with no additional weight on it.**

## Chain Lubrication

Lubrication is necessary every 200 miles (300 Km) and also after riding in wet weather, on wet roads, or any time that the chain appears dry.

Use the special chain lubricant as recommended in the specification section.

Correct application is critical for chain lubrication. Apply the lubricant for one full chain revolution only, then leave for eight hours before riding. This allows the lubricant's solvent (used to thin the oil) to evaporate and the oil to 'soak' into all parts of the chain. If the lubricant is applied and the motorcycle is ridden shortly afterwards, the lubricant is unlikely to reach all parts and the majority will be flung off and wasted. Applying excessive amounts is not helpful under any circumstances.

It should be noted that the lubricant is applied to the chain to lubricate its action across the sprockets. In an O-ring chain, external lubrication does not penetrate to the bushes and rollers as the O-ring seals prevents this from happening.

### Caution

Do not use a power 'jet' wash to clean the chain as this may cause damage to the chain components.

## Chain Adjustment

### Chain Free-movement Inspection

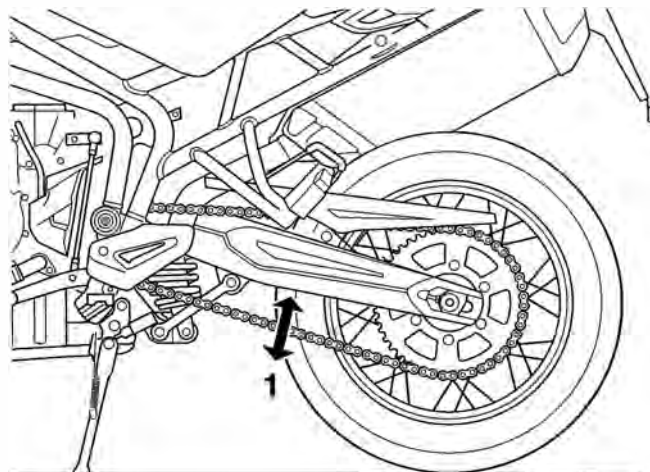

cgjt

#### 1. Maximum movement position

### Warning

Before starting work, ensure the motorcycle is stabilised and adequately supported. This will help prevent it from falling and causing injury to the operator or damage to the motorcycle.

1. Place the motorcycle on a level surface and hold it in an upright position with no weight on it.
2. Rotate the rear wheel by pushing the motorcycle to find the position where the chain has least slack. Measure the chain's vertical movement, mid-way between sprockets.
3. If correct, the vertical movement of the drive chain midway between the sprockets should be:
  - 15 - 25 mm for the Tiger 800;
  - 20 - 30 mm for Tiger 800XC.

## Chain Free-movement adjustment

1. Loosen the wheel spindle nut.
2. Release the locknuts on both the left hand and right hand chain adjuster bolts.

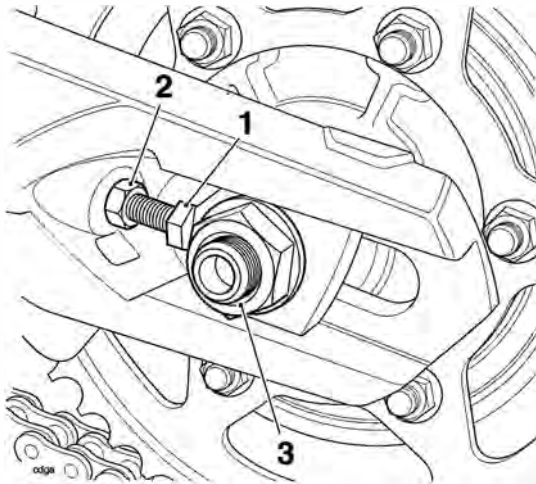

1. Adjuster bolt locknut
2. Adjuster bolt
3. Rear wheel spindle nut

3. Moving both adjusters by an equal amount, turn the adjuster bolts clockwise to increase chain free movement and counter clockwise to reduce chain free movement.
4. When the correct amount of chain free movement has been set, push the wheel into firm contact with the adjusters.

### Note:

- Check for equal adjustment on both sides using the graduation marks on the swinging arm.

5. Tighten both adjuster locknuts to **15 Nm** and the rear wheel spindle nut to **110 Nm**.
6. Repeat the chain adjustment check. Re-adjust if necessary.

### Warning

Operation of the motorcycle with insecure adjuster locknuts or a loose wheel spindle may result in impaired stability and handling of the motorcycle. This impaired stability and handling may lead to loss of motorcycle control and an accident.

7. Check the rear brake effectiveness. Rectify if necessary.

### Warning

It is dangerous to operate the motorcycle with defective brakes; you must have your authorised Triumph dealer take remedial action before you attempt to ride the motorcycle again. Failure to take remedial action may reduce braking efficiency leading to loss of motorcycle control and an accident.

## Chain Wear Inspection

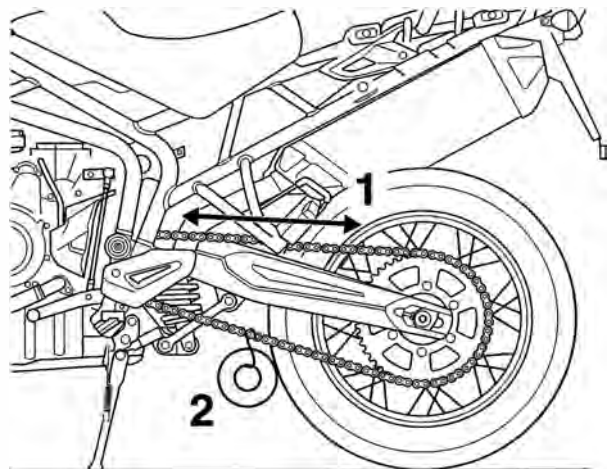

cgjt

1. Measurement across 20 links
2. 10-20kg Weight

### Warning

Before starting work, ensure the motorcycle is stabilised and adequately supported. This will help prevent it from falling and causing injury to the operator or damage to the motorcycle.

1. Remove the chain guard from the swinging arm.
2. Stretch the chain taut by hanging a 10-20 kg (20-40 lb) weight on the chain.
3. Measure a length of 20 links on the straight part of the chain from pin centre of the 1st pin to pin centre of the 21st pin. Repeat the test at various sections of the chain to establish an average reading. This is because the chain may wear unevenly.
4. If the length exceeds the service limit of 319 mm (12.56 in), the chain must be replaced.

### Warning

A chain that breaks or jumps off the sprockets could snag on the engine sprocket or lock the rear wheel, severely damaging the motorcycle and causing loss of control and an accident.

## Rear Suspension

5. Examine the whole length of the chain. If there are any excessively tight or loose sections, loose pins or damaged rollers, the chain should be replaced.
6. Inspect sprockets for unevenly or excessively worn teeth. Also examine the sprockets for damaged teeth.

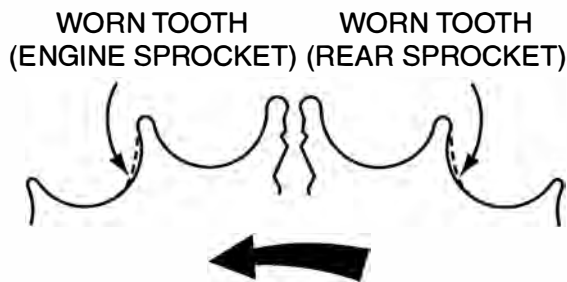

### Note:

- **Sprocket wear is exaggerated for illustration purposes.**

### Warning

The use of non-approved chains may result in a broken chain or may cause the chain to jump off the sprockets. Use a genuine Triumph supplied chain as specified in the Triumph Parts Catalogue. Never neglect chain maintenance and always have chains installed by an authorised Triumph dealer.

7. If there is any irregularity found in any of the components, replace the drive chain and/or any other damaged components.
8. Refit the chain guard, tightening the fixings to **9 Nm**.

## Rear Suspension Unit

### Removal

### Warning

If the engine has recently been running, the exhaust system will be hot. Before working on or near the exhaust system, allow sufficient time for the exhaust system to cool as touching any part of a hot exhaust system could cause burn injuries.

### Warning

Before starting work, ensure the motorcycle is stabilised and adequately supported. This will help prevent it from falling and causing injury to the operator or damage to the motorcycle.

1. Raise and support the rear of the motorcycle under the frame or engine. Position a block to support the rear wheel.
2. Remove the seats (see page 16-13).
3. Disconnect the battery, negative (black) lead first.
4. **Tiger 800XC models only:** Remove the fuel tank infill panel (see page 16-18).
5. Loosen the two clips and detach the rear suspension unit remote reservoir from the frame.

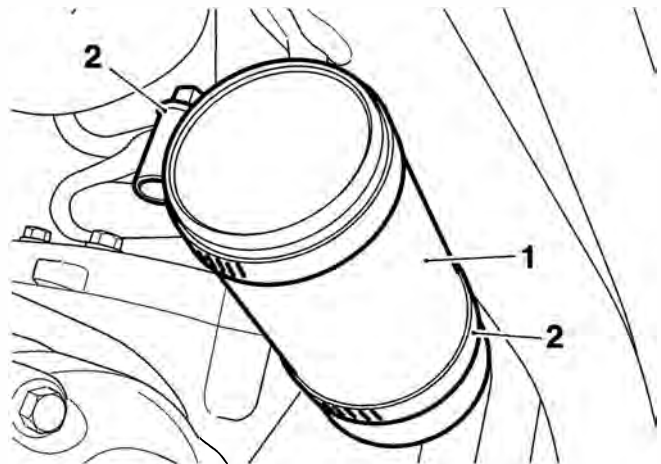

### 1. Remote reservoir

### 2. Clips

6. **All models:** Remove the drag link to rear suspension unit fixing. Discard the nut.
7. Remove the drop link to swinging arm fixing. Discard the nut.

8. Reposition the drop link plates and position the drag link clear of the rear suspension unit.

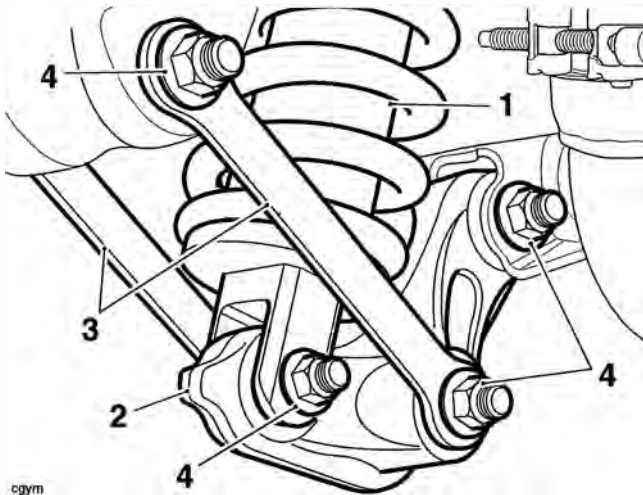

- cgym
1. Rear suspension unit
  2. Drag link
  3. Drop link
  4. Fixings

## Warning

Never attempt to disassemble the rear suspension unit or remote reservoir. It contains fluid under pressure and serious injury could result if any part of the system is disturbed.

9. Remove the rear suspension unit upper mounting nut and bolt.
10. **Tiger 800 models:** Manoeuvre the unit downwards through the swinging arm and clear of the motorcycle.
11. **Tiger 800XC models:** Manoeuvre the unit downwards through the swinging arm and clear of the motorcycle, at the same time passing the remote reservoir through the frame and then through the swinging arm.

## Inspection

1. Clean all components and inspect for damage/wear to:
  - rear suspension unit upper and lower mountings;
  - drag link, drag link bearings, sleeves and seals;
  - drop link plates, drop link bearings, sleeves and seals.
2. Renew as necessary.
3. Check the swinging arm drop link bearings for wear. Overhaul as necessary.

4. Check the drag link bearings for wear. Overhaul as necessary (see page 12-13).

## Warning

Never attempt to disassemble the rear suspension unit or remote reservoir. It contains fluid under pressure and serious injury could result if any part of the system is disturbed.

5. Inspect the remote reservoir and hose (Tiger 800XC only) and the suspension unit itself for damage and fluid leaks. If there is any damage, or fluid leaks are evident, the unit must be replaced.

## Installation

1. Remove the drag link sleeves and pack the bearings with fresh grease. Refit the sleeves.
2. Remove the swinging arm drop link sleeve and pack the bearings with fresh grease. Refit the sleeve.
3. **Tiger 800XC models:** Pass the remote reservoir upwards through the swinging arm and through the frame, as the rear suspension unit is positioned to the motorcycle.
4. Locate the rear suspension unit and loosely fit the upper mounting bolt and a new nut.
5. Position the remote reservoir to the frame and secure with the two clips, tightening to **3 Nm**. Ensure the hose is not twisted, or positioned so that it will chafe against any part of the motorcycle.
6. Refit the fuel tank infill panel (see page 16-21).
7. **Tiger 800 models:** Refit the rear suspension unit to the motorcycle by raising the unit upwards through the hole in the swinging arm.
8. Locate the rear suspension unit and loosely fit the upper mounting bolt and a new nut.

## Rear Suspension

9. **All models:** Locate the drag link to the rear suspension unit and, from the left hand side, loosely fit the bolt and a new nut.
10. Reposition the drop link plates and, from the left hand side, loosely fit the bolt and a new nut.

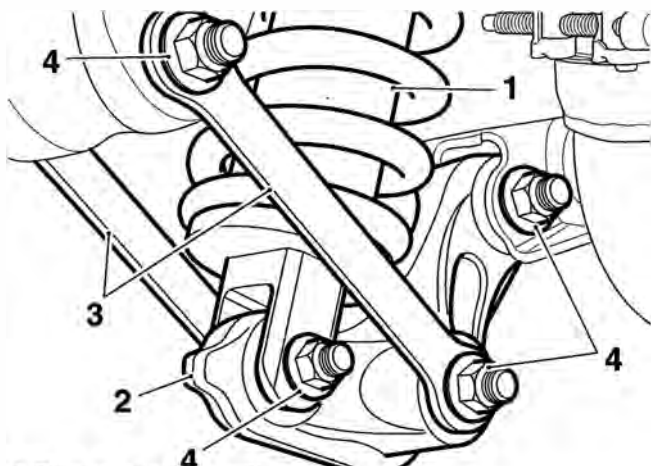

1. Rear suspension unit
2. Drag link
3. Drop links
4. Fixings

11. Tighten the drop link fixing to **80 Nm**.
12. Tighten the drag link to rear suspension unit fixing to **80 Nm**.
13. With the weight of the motorcycle on its wheels, tighten the rear suspension unit upper mounting to **48 Nm**.
14. Connect the battery, red (positive) lead first.
15. Fit the seats (see page 16-13).

## Drag Link and Drop Links

### Removal

#### Warning

If the engine has recently been running, the exhaust system will be hot. Before working on or near the exhaust system, allow sufficient time for the exhaust system to cool as touching any part of a hot exhaust system could cause burn injuries.

#### Warning

Before starting work, ensure the motorcycle is stabilised and adequately supported. This will help prevent it from falling and causing injury to the operator or damage to the motorcycle.

1. Raise and support the rear of the motorcycle beneath the frame or engine. Position a block to support the rear wheel.
2. Remove the seats (see page 16-13).
3. Disconnect the battery, negative (black) lead first.
4. Remove the fixings securing the drop links to the swinging arm and drag link, and remove the drop link plates.
5. Remove the two fixings securing the drag link to the frame and rear suspension unit.
6. Remove the drag link.

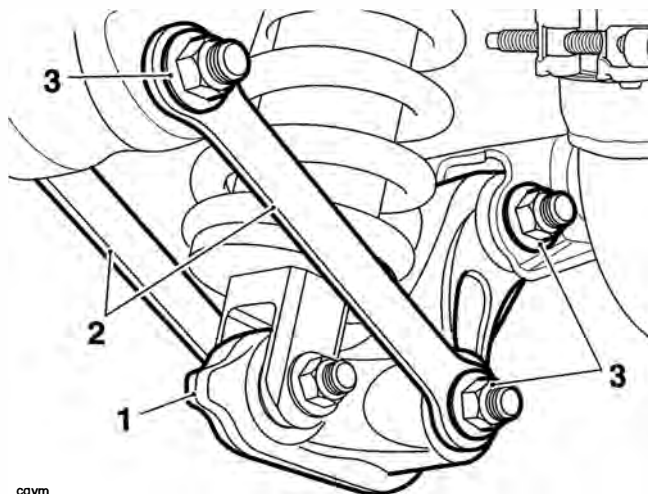

cgym

1. Drag link
2. Drop links
3. Fixings

## Inspection

1. Clean all components and inspect the drag link and bearings for damage/wear.
2. Check the rear suspension unit lower bearings for wear.
3. Check the drop link bearings for wear.
4. Renew as necessary.

## Installation

1. Remove the drag link sleeves and pack the bearings with fresh grease. Refit the sleeves.
2. Remove the swinging arm drop link sleeve and pack the bearings with fresh grease. Refit the sleeve.
3. Refit the drag link to the frame and rear suspension unit, installing the bolts from the left hand side.
4. Fit new nuts, tightening to **80 Nm**.
5. Refit the drop link plates, installing the bolts from the left hand side.
6. Fit new nuts, tightening to **80 Nm**.
7. Connect the battery, red (positive) lead first.
8. Fit the seats (see page 16-13).

## Swinging Arm

### Removal

#### Warning

If the engine has recently been running, the exhaust system will be hot. Before working on or near the exhaust system, allow sufficient time for the exhaust system to cool as touching any part of a hot exhaust system could cause burn injuries.

#### Warning

Before starting work, ensure the motorcycle is stabilised and adequately supported. This will help prevent it from falling and causing injury to the operator or damage to the motorcycle.

1. Remove the seats (see page 16-13).
2. Disconnect the battery, negative (black) lead first.
3. Remove the exhaust silencer (see page 10-118).
4. Remove the rear wheel (see page 15-12).
5. Support the swinging arm and remove the drop link to swinging arm nut and bolt. Discard the nut.

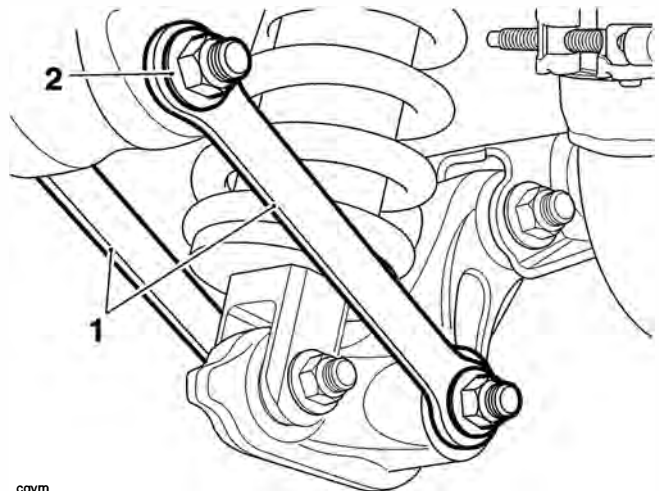

cgym

#### 1. Drop links

#### 2. Fixing

6. Remove the sprocket cover.
7. Detach the chain from the output sprocket.

# Rear Suspension

## Warning

Do not allow the caliper to hang on the brake hose as this may damage the hose and could lead to an accident.

8. Release the brake hose clips from the swinging arm and tie the rear brake caliper to one side.

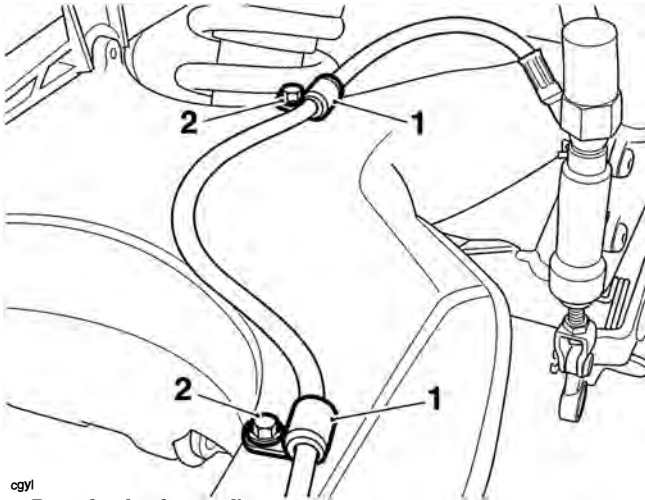

ogy!

**1. Rear brake hose clips**

**2. Fixings**

9. Remove the swinging arm spindle nut. Discard the nut.
10. Withdraw the swinging arm spindle from the right hand side and remove the swinging arm, unhooking it from the drive chain as you do so.

- **Support the drive chain while the swinging arm is being removed to protect it from contamination.**

### Disassembly

1. Remove the dust covers from both sides.
2. Remove the bearing sleeves from both sides.
3. Remove the four seals

4. Remove the bearings by drifting through from the outside.

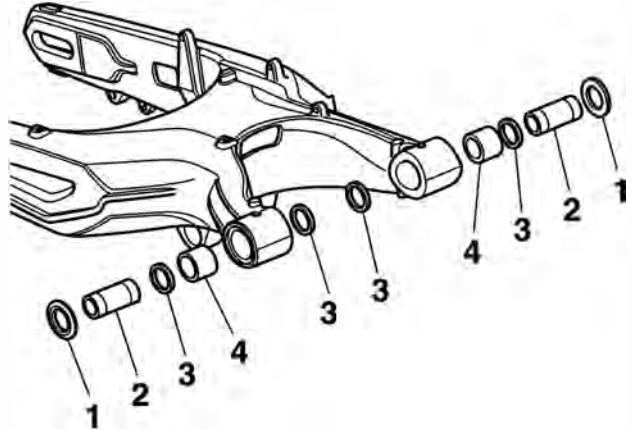

**1. Dust cover**

**2. Bearing sleeve**

**3. Seal**

**4. Needle roller bearing**

5. Remove the drive chain rubbing strip.

### Inspection

1. Check all swinging arm bearings for damage, pitting, and cracks. Replace as necessary.
2. Check the swinging arm for damage. Replace as necessary.
3. Check the rear wheel bearings for damage, pitting, and cracks. Replace as necessary.
4. Check all bearing seals for damage, splits etc. Replace as necessary.
5. Check the drive chain for wear, damage etc. Replace as necessary.
6. Check both sprockets for wear, damage etc. Replace as necessary.
7. Check the drive chain rubbing strip for wear and damage. Replace as necessary.



## Assembly

1. Install the bearings (marked faces outwards), sleeves etc. into the swinging arm in the order shown on the previous page. Use new seals and dust covers throughout.
2. Fit the drive chain rubbing strip and tighten the fixing to **9 Nm**.
3. Fit the drive chain to the output sprocket.
4. Position the swinging arm to the frame ensuring the drive chain is in position on the rubbing strip.
5. Refit the swinging arm spindle from the right hand side.
6. Fit a new swinging arm spindle nut and tighten to **110 Nm**.
7. Refit the sprocket cover and tighten the bolts to **9 Nm**.
8. Release the caliper and refit the rear brake hose clips to the swinging arm. Tighten the fixings to **6 Nm**.

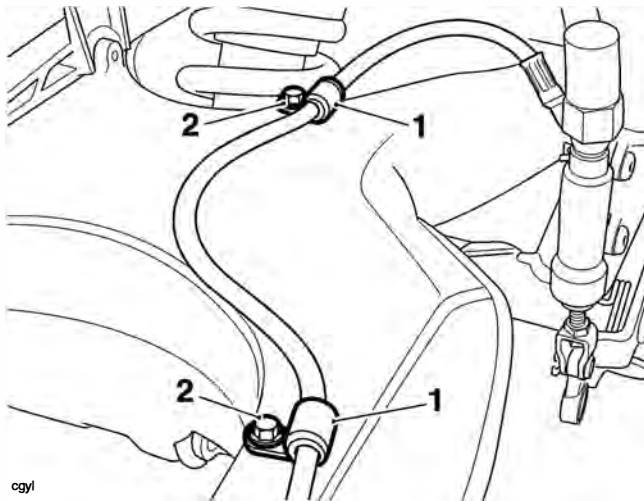

cgyl

1. Rear brake hose clips
2. Fixings

9. Refit the rear wheel (see page 15-12).
10. Refit the exhaust silencer (see page 10-95).
11. Connect the battery, red (positive) lead first.
12. Fit the seats (see page 16-13).
13. Pump the rear brake pedal several times to position the brake pads in the caliper. Rectify as necessary if correct brake operation is not restored (see page 14-23).

## Warning

It is dangerous to operate the motorcycle with defective brakes; you must have your authorised Triumph dealer take remedial action before you ride the motorcycle again. Failure to take remedial action may result in reduced braking efficiency leading to loss of motorcycle control and an accident.

## Drive Chain Replacement

### Rivet link type

The following instructions for the replacement of rivet link type drive chains requires the use of service tool T3880027.

## Warning

Before starting work, ensure the motorcycle is stabilised and adequately supported. This will help prevent it from falling and causing injury to the operator or damage to the motorcycle.

1. Support the motorcycle on a stand so the rear wheel is clear of the ground.
1. Support the motorcycle on a stand so the rear wheel is clear of the ground.
2. Insert the hollow chain cutting tail piece into the tool body so its larger diameter end is facing towards the large pressure screw as shown.

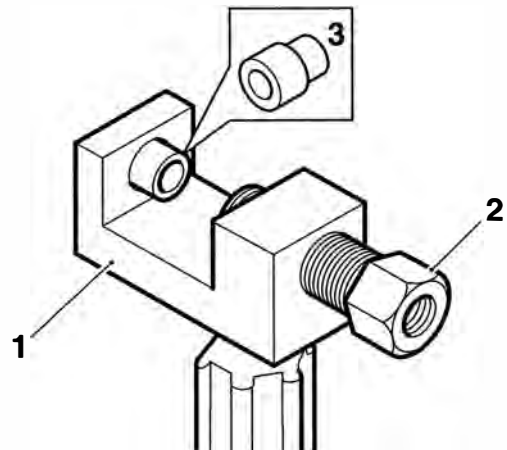

cdqk

1. Tool T3880027
2. Large pressure screw
3. Chain cutting tail piece

# Rear Suspension

- Position the chain to the tool ensuring that the chain link pin which is to be removed is aligned with the holes in the chain cutting tail piece and the large pressure screw. Tighten the large pressure screw by hand to grip the chain.

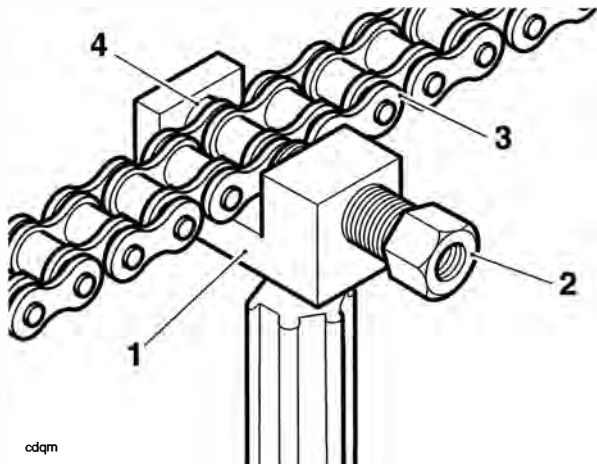

cdqm

- Tool T3880027**
- Large pressure screw**
- Chain**
- Chain cutting tail piece**

- Insert the small pressure screw into the larger pressure screw as shown below, until the cutting pin on the small pressure screw contacts the link pin. Ensure that the cutting pin is centralised on the link pin to be removed.

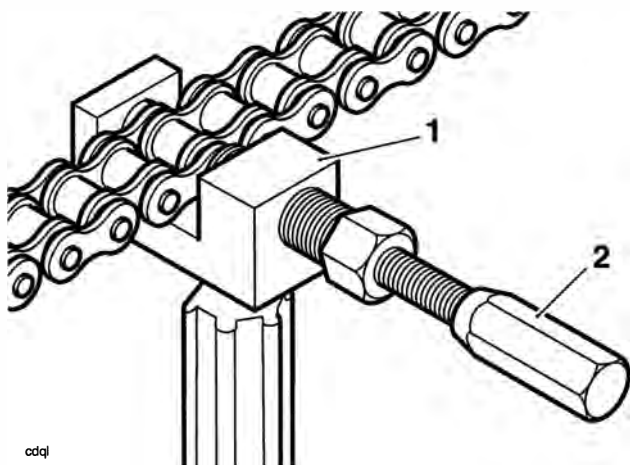

cdqj

- Tool T3880027**
- Small pressure screw**

- Retain the tool body then tighten the small pressure screw until the link pin is pressed out from the chain.
- Repeat steps 3 to 5 on the remaining chain link pin.
- Remove the tool and separate the two ends of the chain.
- Remove the chain cutting tail piece from the body.

## Note:

- The replacement chain is supplied in a split condition, complete with a link kit to join the two ends.**



## Caution

The component parts of the new link kit are coated with a special grease which must not be removed. Removal of this special grease will severely reduce the service life of the chain.

- Use the old drive chain to pull the new chain into position as follows: Temporarily attach the end of the new chain to a free end of the old chain using the old connector link. Carefully pull the other end of the old chain to pull the new chain around the sprockets.

## Note:

- Do not use the new connector link as the special grease on it may be removed.**
- Using the new link supplied with the chain kit, join the two ends of the chain. Ensure that the O-rings are positioned as shown below and the link plate is fitted with its markings facing outwards.

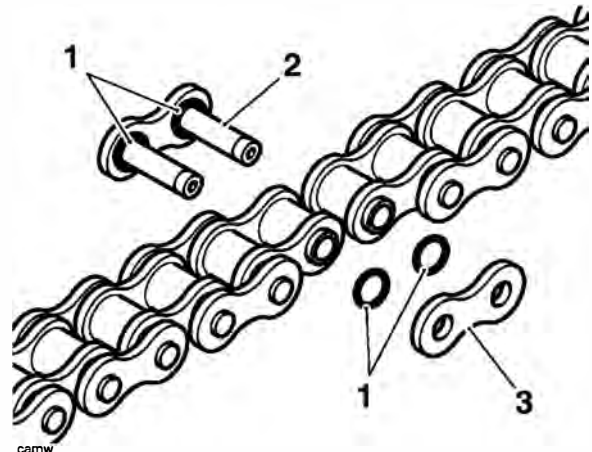

camw

- O-rings**
- Link**
- Link plate**

- Insert the riveting tail piece into the tool body so its larger diameter end is facing towards the large pressure screw as shown.

## Note:

- Tool T3880027 includes two link plate holders, one is for riveted link plates (marked PH5060R), the other is for link plates retained by a spring clip (marked PH4060C). The holder for riveted link plates has a shallow groove to allow for chain link clearance, the holder for clipped link plates has a deep groove to allow for chain link clearance.**

12. Insert the link plate holder (marked PH5060R) into the large pressure screw.

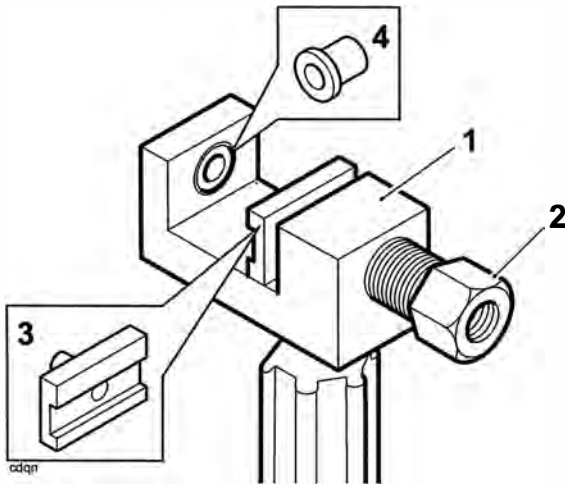

- 1. Tool body**  
**2. Large pressure screw**  
**3. Link plate holder (marked PH5060R)**  
**4. Riveting tail piece**

13. Position the tool to the chain. Ensure the link plate holder is correctly located in the large pressure screw.

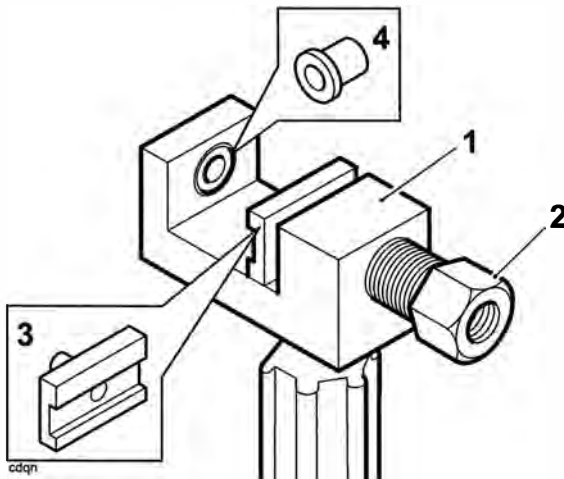

- 1. Tool body**  
**2. Large pressure lever**  
**3. Link plate holder (marked PH 5060R)**  
**4. Riveting tail piece**

14. Locate the split link pins such that the pins will enter the groove in the link plate holder when the link plate is pressed on to the link.

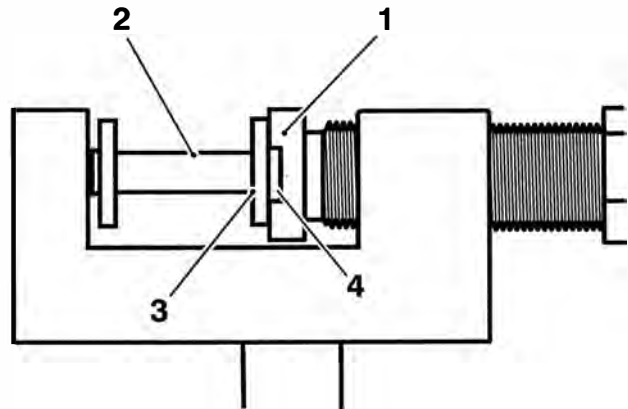

- 1. Link plate holder**  
**2. Link plate**  
**3. Chain link**  
**4. Link plate holder groove**

15. Retain the tool body and tighten the large pressure screw until the link plate is pressed fully onto the link.  
 16. Back off the pressure screw, slide the tool assembly to one side and check that the split link is correctly assembled.  
 17. Remove the link plate holder from the tool. Do not remove the riveting tail piece from the tool  
 18. Insert the flare pin into the large pressure screw.

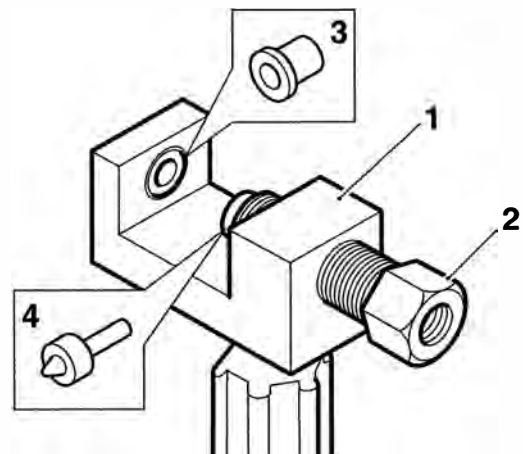

- 1. Tool body**  
**2. Large pressure screw**  
**3. Riveting tail piece**  
**4. Flair pin**

19. Locate one of the split link pins into the riveting tail piece and screw the large pressure screw in until the flare pin contacts the split link end. Ensure the split link pin is centrally located on the flare pin.

## Rear Suspension

20. Retain the tool body and tighten the large pressure screw until the split link end is riveted-over.

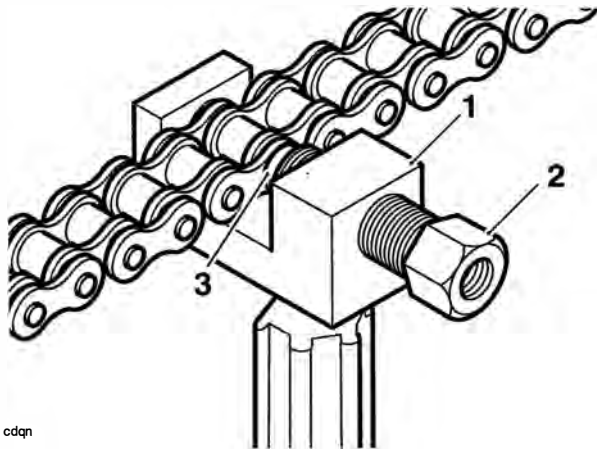

cdqn

1. Tool body
2. Large pressure screw
3. Flare pin

21. Back off the large pressure screw and rivet the remaining split link pin as described above.

22. Remove the tool from the chain and check that both the split link pins are correctly riveted as shown below.

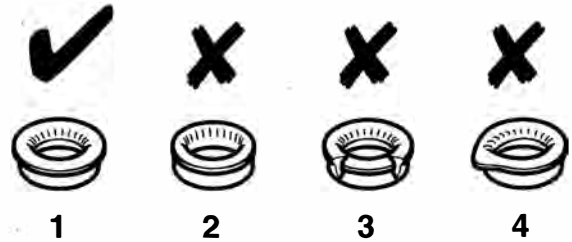

cana

1. Correct riveting
2. Insufficient riveting
3. Excessive riveting
4. Riveting off-centre



### Warning

If either split link pin is not correctly riveted, the split link must be removed and replaced with a new link. Never operate the motorcycle with an incorrectly riveted split link as the link could fail resulting in an unsafe riding condition leading to loss of control and an accident.

# 13 Front Suspension

## Table of Contents

Exploded View - Front Fork - Tiger 800.....	13.2
Exploded View - Front Fork - Tiger 800 XC.....	13.3
Exploded View - Handlebars.....	13.4
Front Suspension.....	13.5
Fork Inspection.....	13.5
Front Fork.....	13.5
Removal.....	13.5
Installation.....	13.6
Fork Oil Change.....	13.7
Draining.....	13.7
Oil Refilling.....	13.7
Fork Oil Level Chart.....	13.8
Front Fork.....	13.9
Disassembly.....	13.9
Inspection.....	13.12
Assembly.....	13.12
Headstock Bearing Check/Adjustment.....	13.15
Check.....	13.15
Adjustment.....	13.15
Headstock Bearing Removal.....	13.17
Inspection.....	13.18
Installation.....	13.18
Handlebars.....	13.19
Removal.....	13.19
Installation.....	13.21

# Front Suspension

## Exploded View - Front Fork - Tiger 800

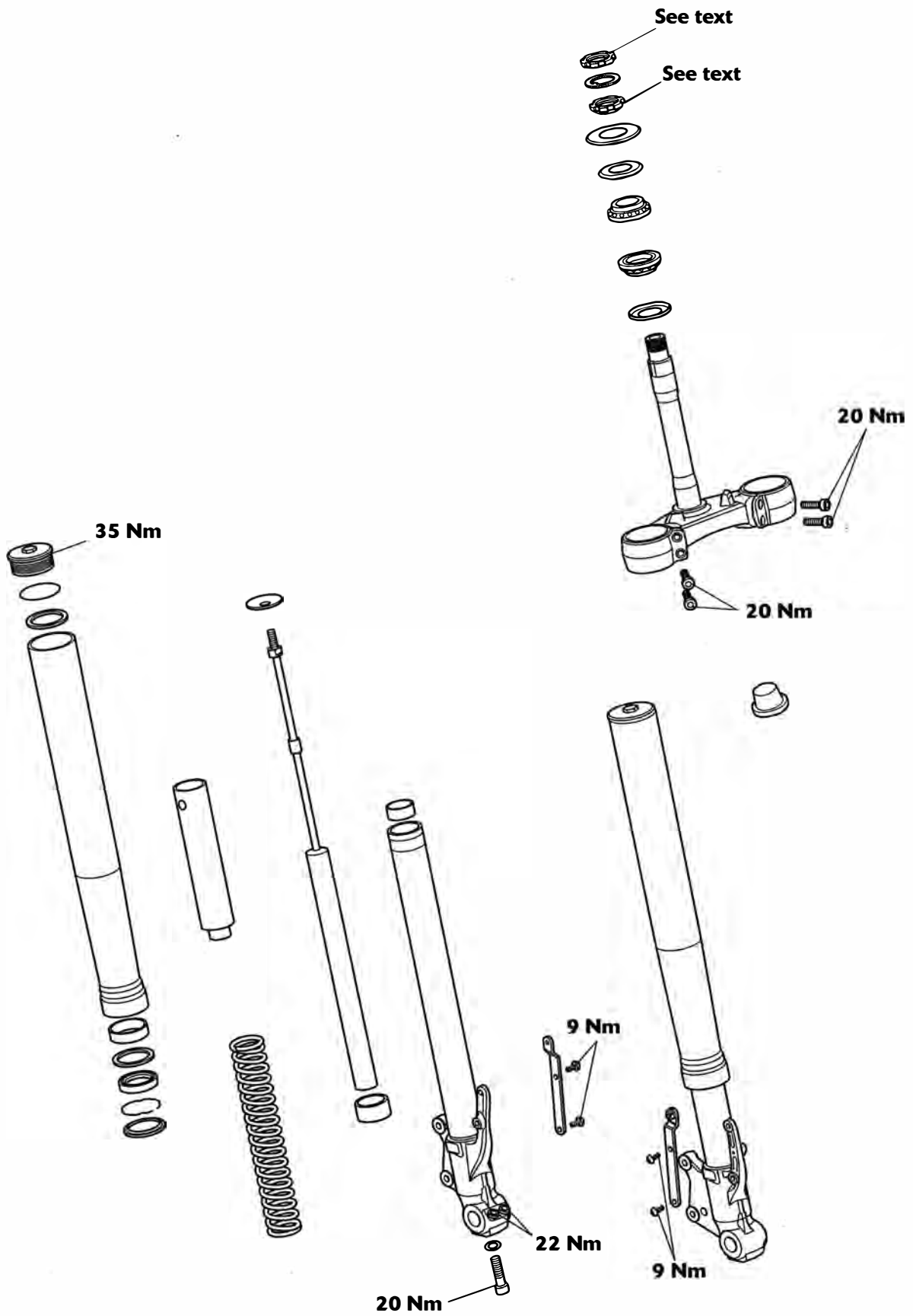

## Exploded View - Front Fork - Tiger 800XC

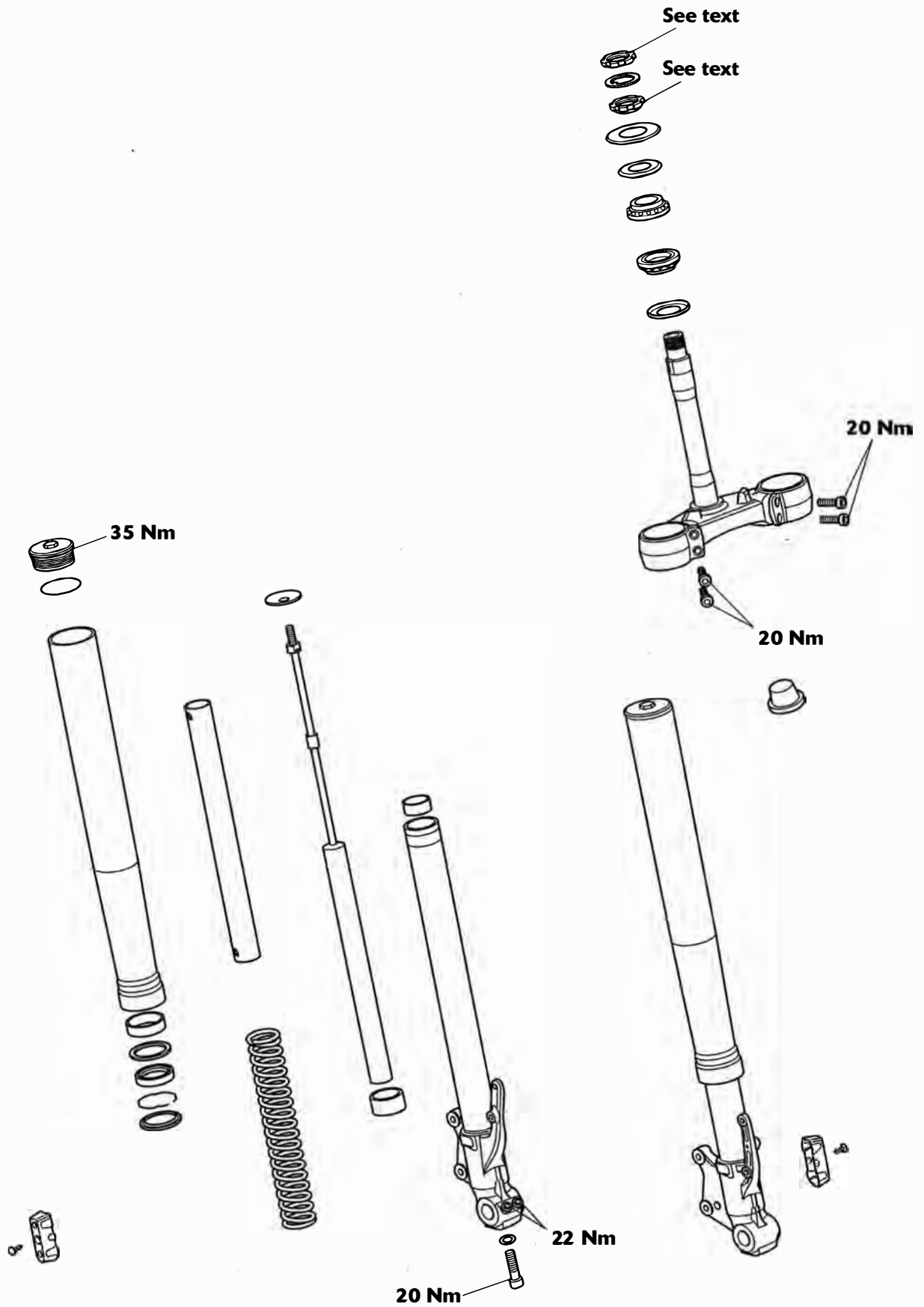

# Front Suspension

## Exploded View - Handlebars

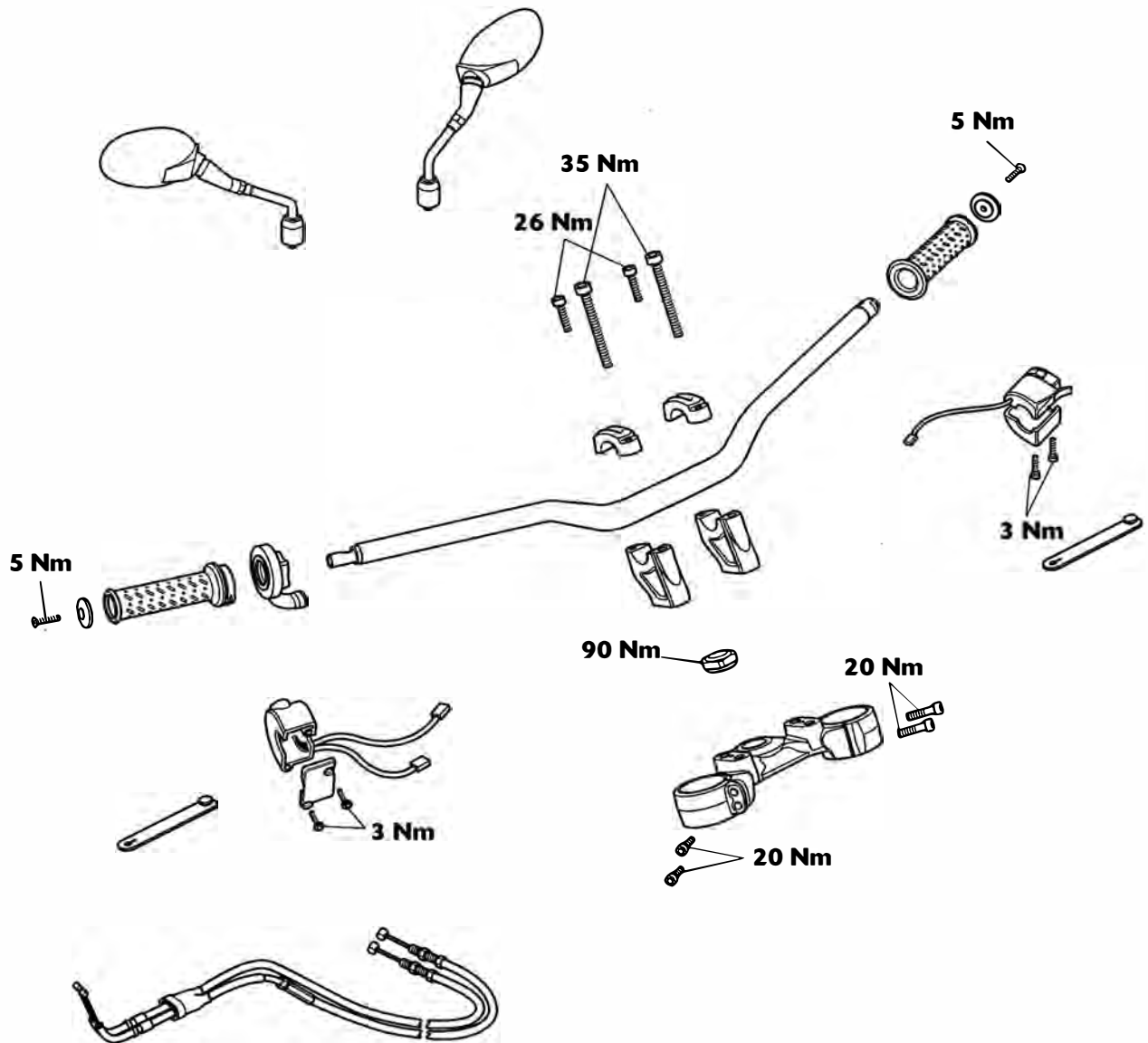



## Front Suspension

The Tiger 800 and Tiger 800XC models are equipped with hydraulic, telescopic front forks. The front suspension has no adjustments.

Periodic inspection for damage and fluid leaks is essential for safe riding. Always follow the inspection instructions at the intervals stated in the scheduled maintenance chart.

### Fork Inspection

Examine each fork for any sign of damage or scratching of the slider surface or for oil leaks.

If any damage or oil leakage is found, strip and repair as described in this section or consult an authorised Triumph dealer.

Check for smooth operation of the forks as follows:

- Place the motorcycle on level ground.
- While holding the handlebars and applying the front brake, pump the forks up and down several times.

If roughness or excessive stiffness is detected, repair as described in this section or consult an authorised Triumph dealer.

### Warning

Riding the motorcycle with defective or damaged suspension can cause loss of motorcycle control and an accident. Never ride with damaged or defective suspension.

## Front Fork

### Removal

### Warning

Before starting work, ensure the motorcycle is stabilised and adequately supported. This will help prevent it from falling and causing injury to the operator or damage to the motorcycle.

1. Raise and support the front of the motorcycle.
2. Remove the front wheel (see page 15-10).
3. Remove the front mudguard (see page 16-19 Tiger 800 for and 16-20 for Tiger 800XC).
4. Detach and support the front brake calipers (see page 14-16).

### Warning

Never allow the brake calipers to hang on the brake hoses as this may damage the hoses. A damaged brake hose can cause a reduction in braking efficiency leading to loss of motorcycle control and an accident.

### Note:

- If the forks are to be dismantled, slacken the fork top cap, and if the damper cylinder is to be removed, slacken the lower damper cylinder bolt.
5. Release the fixing and detach the brake hose from the clip on the fork leg.

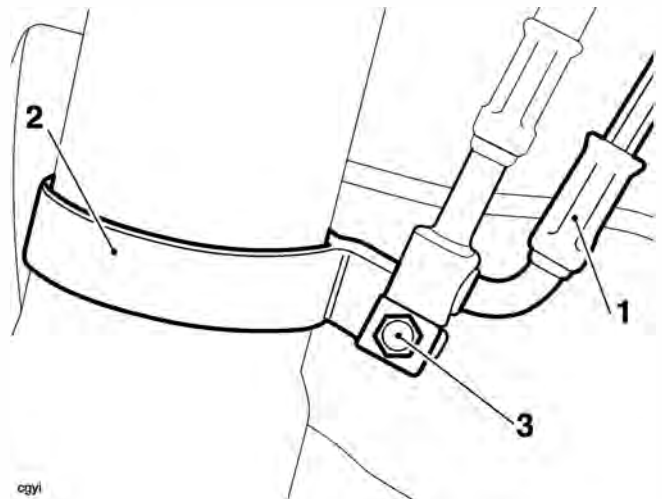

1. Brake hose
2. Brake hose clip
3. Fixing

# Front Suspension

6. Slacken the top yoke clamp bolts.

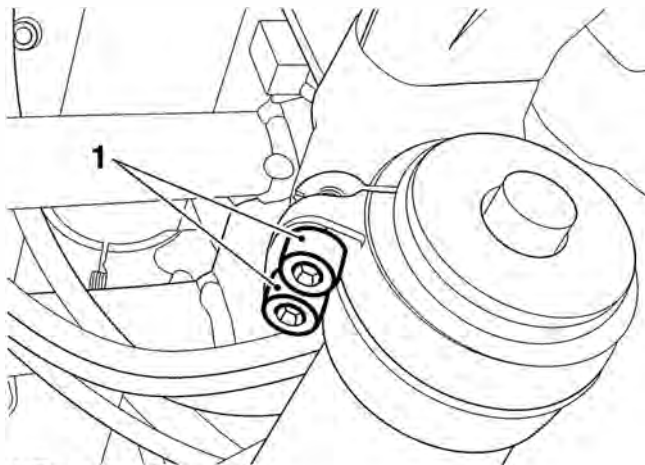

1. Top yoke clamp bolts



## Caution

Care must be taken when removing the forks, to ensure that the outer surfaces do not become scratched.

7. Slacken the bottom yoke clamp bolts.

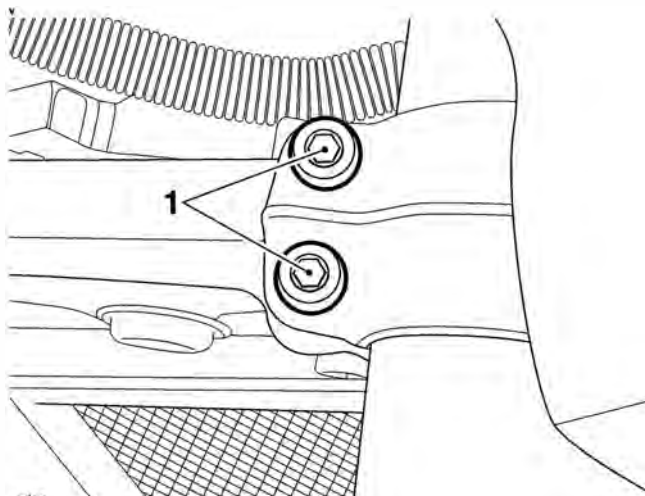

1. Bottom yoke clamp bolts

8. Using a downward, twisting action, withdraw the forks from between the yokes.

## Installation

1. Position the forks within the yokes so that the lip of the outer tube, not the top cap, is 4 mm above the upper surface of the top yoke.

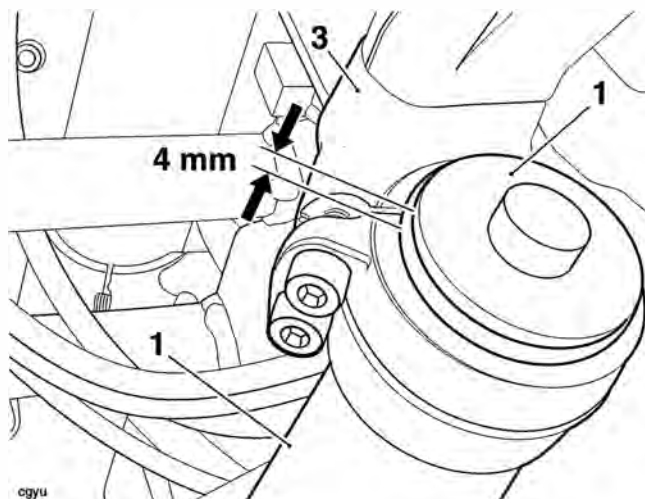

1. Outer tube

2. Top cap

3. Top yoke

2. Tighten the bottom yoke clamp bolts to **20 Nm**.

3. Tighten the top yoke clamp bolts to **20 Nm**.

### Note:

- If the forks have been dismantled, tighten the fork top caps to **35 Nm**, and if removed, the lower damper cylinder bolt to **20 Nm**.
4. Refit the front mudguard (see page 16-21 Tiger 800 for and 16-21 for Tiger 800XC).

- Position the brake hose to the fork leg clip and secure with the bolt, tightening to **6 Nm**.

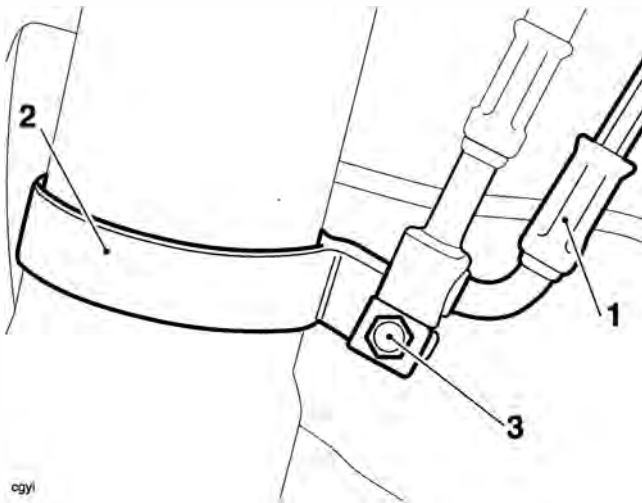

cgyl

- Brake hose**
- Brake hose clip**
- Fixing**

- Install the front wheel (see page 15-11).
- Refit the front brake calipers (see page 14-18).
- Lower the motorcycle to the ground and park it on the side stand.

## Fork Oil Change

### Draining



### Warning

Before starting work, ensure the motorcycle is stabilised and adequately supported. This will help prevent it from falling and causing injury to the operator or damage to the motorcycle.

- Remove the fork (see page 13-5).
- Remove the top cap assembly (see page 13-9).
- Remove the fork spring (see page 13-9).
- Holding the inner and outer tubes together, invert the fork and pour out the fork oil into a suitable container. Pump the damper rod to remove all the oil.

### Oil Refilling

The oil level is measured from the upper surface of the fork outer tube, with the fork fully compressed and the spring removed.

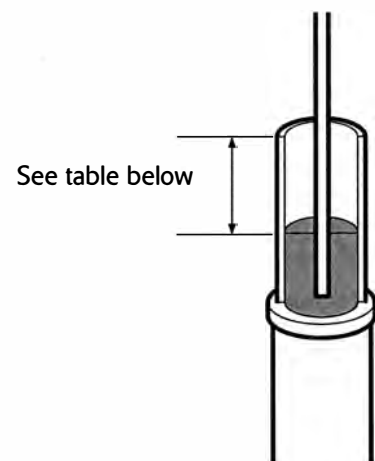

cbyf

### Fork Oil Level (fully compressed)

Model	Oil Level
Tiger 800	103 mm
Tiger 800XC	107 mm

- Fill the fork with the grade of oil specified in the fork oil table, to a level above that which will finally be required.
- Pump the fork assembly and damper several times to expel any trapped air then fully compress the fork and support it in an upright position. Leave the fork for a few minutes to allow the oil to stabilise.

# Front Suspension

- Refer to the fork oil level chart and set the scale on tool 3880160-T0301 to the relevant distance, as shown below.

Refer to fork oil level chart

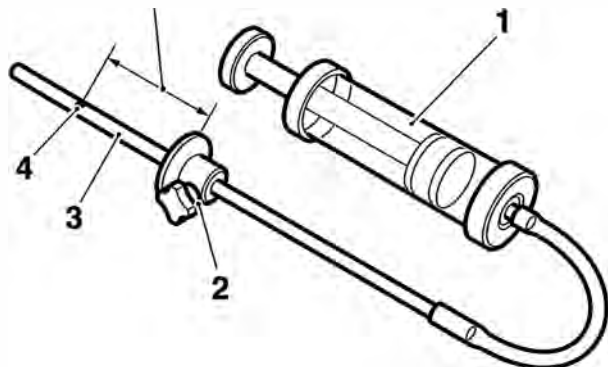

cbvg

- Tool 3880160-T0301
- Adjustment plate
- Scale area
- Hole (zero position)

**Note:**

- Zero level on the tool is set at the small exit hole in the side of the scale tube, **NOT AT THE END TIP**. Do not attempt to block this side hole as this will cause the final fluid level to be incorrect.
- Insert the scale end of the tool into the fork inner tube.
  - Hold the tool adjuster plate level with the upper surface of the fork inner tube and draw fluid into the syringe until fluid flow ceases (empty the syringe if the body becomes full before fluid flow stops).
  - The fluid level in the fork is now set to the height set on the tool scale. Check the tool scale setting and repeat the process if incorrectly set.

**Warning**

Incorrect fork oil levels could result in an unsafe riding condition leading to loss of control and an accident.

- Assemble the fork (see page 13-12).
- Refit the fork (see page 13-6).

**Fork Oil Level Chart**

Tiger 800			
Oil Level*	Oil Volume	Oil Grade	Fork Pull Through
103 mm	553 cc	Showa SS 8	Top of the inner tube 4 mm above the upper face of the top yoke
Tiger 800XC			
Oil Level*	Oil Volume	Oil Grade	Fork Pull Through
107 mm	619 cc	Showa SS 8	Top of the inner tube 4 mm above the upper face of the top yoke

**\*Fork Fully Compressed**

## Front Fork

### Disassembly

#### Warning

Before starting work, ensure the motorcycle is stabilised and adequately supported. This will help prevent it from falling and causing injury to the operator or damage to the motorcycle.

#### Note:

- Before removing the forks, slacken the top cap a little to allow easier removal during strip-down.
- The fork seals can be renewed without removal of the damping cylinder. Unless removal of the damping cylinder is necessary, omit steps 16 and 17 of this procedure.
- If the damping cylinder is to be removed, loosen the lower damping cylinder bolt before removing the forks.

1. Remove the forks (see page 13-5).
2. Very gently clamp the fork in the soft jawed vice to prevent it from turning, hold the outer tube, then unscrew the top cap from the outer tube.

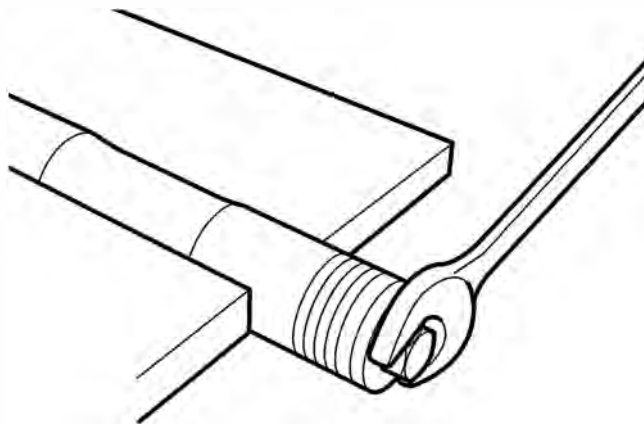

ccun

1. Fork
2. Soft jaws
3. Top cap

#### Caution

Never tightly clamp the outer tube as this will cause the tube to permanently distort. A distorted tube is not serviceable and must be replaced.

#### Note:

- The top cap is not under spring tension and will not spring upwards when the threads disengage.
3. Slacken the locknut, unscrew and remove the top cap. If necessary, remove the O-ring seal from the top cap assembly.
  4. Holding the inner and outer tubes together, invert the fork and pour out the fork oil into a suitable container. Pump the damper rod to remove all the oil.
  5. Return the fork to the soft jawed vice.

#### Warning

While compressing the fork spring always wear protective equipment for the face and eyes and never stand directly above or look directly down on the fork. If the spring compressor should dislodge or detach, the resulting release of spring tension could cause parts to fly off resulting in injury to the user.

6. **Tiger 800XC only:** Fit tool T3880067 over the spring spacer. Position the two adjustable arms to the holes in the spring spacer. Screw in the arms until they positively engage in the spring spacer holes.
7. Using tool T3880067, manually compress the fork spring and remove the split collar from below the damper locknut.

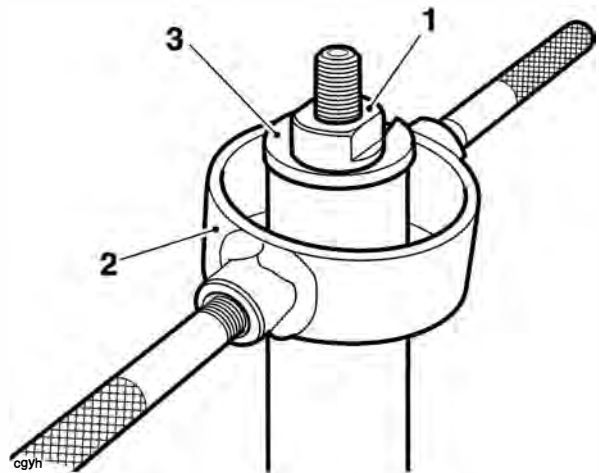

1. Damper locknut
2. Tool T3880067
3. Split collar

8. Remove tool T3880067 from the spring spacer.

#### Note:

- On Tiger 800 models, an assistant may be required to remove the split collar.
9. **Tiger 800 only:** Tool T3880067 is not required; the spring can be compressed by gripping the spring collar by hand and the split collar removed.

# Front Suspension

## Warning

While compressing the fork spring always wear protective equipment for the face and eyes and never stand directly above or look directly down on the fork. If the spring compressor should dislodge or detach, the resulting release of spring tension could cause parts to fly off resulting in injury to the user.

### Note:

- On Tiger 800 models, the spring has a smaller coil diameter at both ends, and can be fitted either way up.
- On Tiger 800XC models, the spring has a smaller coil diameter at its upper end. Note the orientation of the spring before removal.

10. Remove the spring spacer and spring.

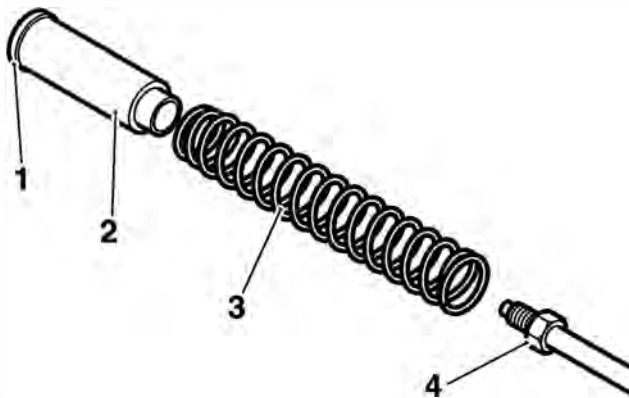

cdno

1. Washer
2. Spring spacer (Tiger 800 shown)
3. Spring
4. Damper rod

### Note:

- To help with identification of the service tools, tool T3880158 has a single groove turned on its outside circumference. Tool T3880154 does not have a groove.

11. Fit both halves of tool T3880158 (for Tiger 800 models) or tool T3880154 (for Tiger 800XC models) to the outer tube as shown below and hold in position.

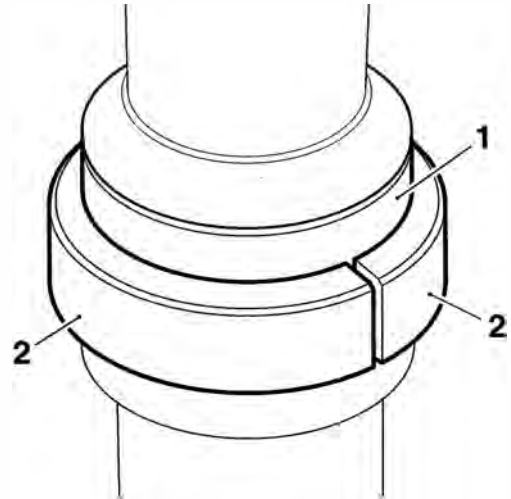

cgrc

1. Outer tube
  2. Tool T3880158 (Tiger 800) or T3880154 (Tiger 800XC)
12. Invert and mount the fork assembly to tool T3880153.

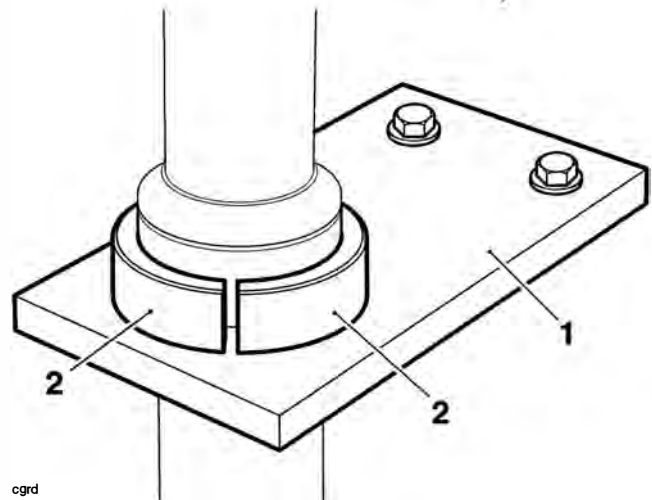

cgrd

1. Tool T3880153
2. Tool T3880158 (Tiger 800) or T3880154 (Tiger 800XC)

13. Raise the inner tube and remove the dust seal from the outer tube.

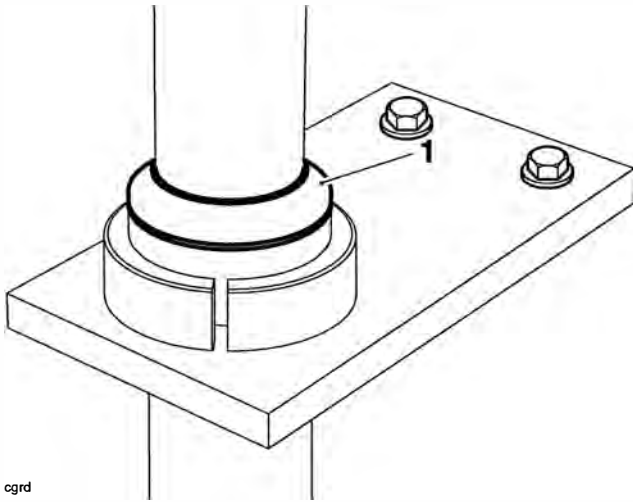

cgrd

**1. Dust seal**

14. Remove the circlip.

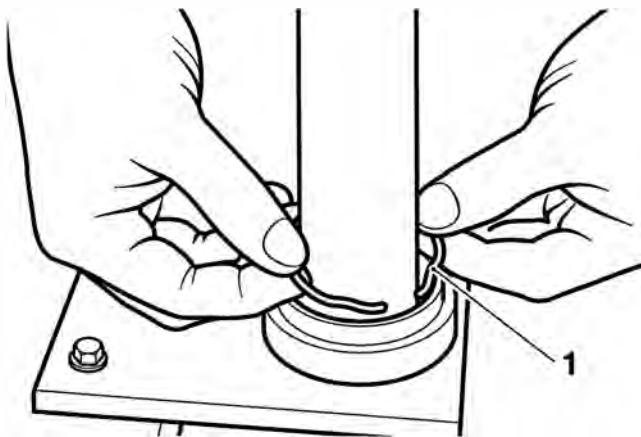

**1. Circlip**

15. Remove the fork from the tool and, using a slide hammer action to release the oil seal and bushes from the outer tube, separate the inner and outer tubes leaving the seals and bushes in place on the inner tube.

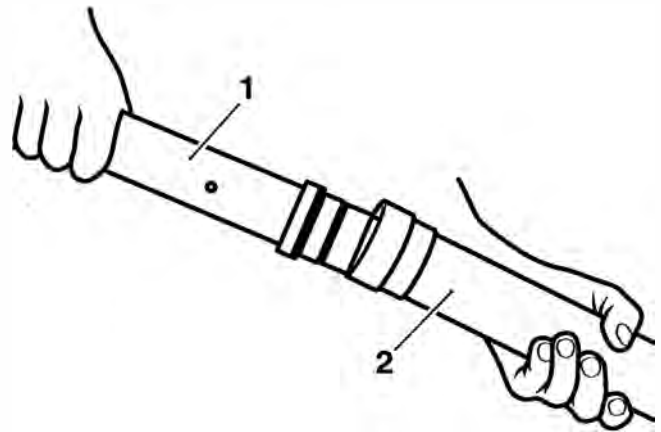

ccuw

**1. Inner tube**

**2. Outer tube**

16. To allow the removal of the seals and bushes, carefully remove the upper bush from the inner tube.

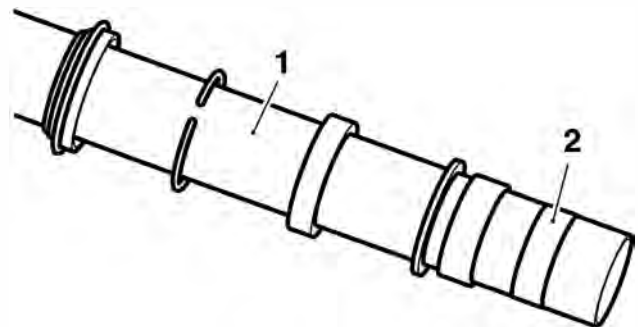

ccup\_3

**1. Inner tube**

**2. Upper bush**

# Front Suspension

17. If removal of the damping cylinder is required, unscrew the damping cylinder bolt from the bottom of the lower fork, then slide the damping cylinder out of the inner tube.  
Collect the centering collar from the lower end of the damping cylinder.

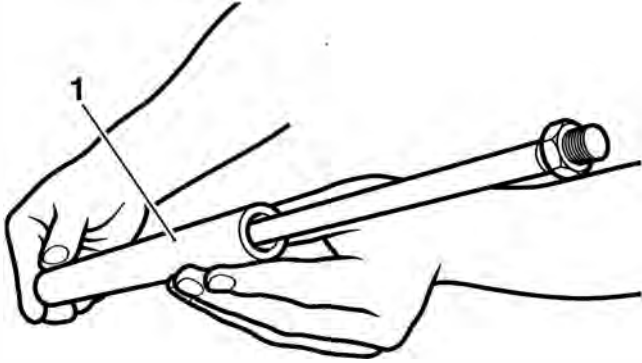

ccuy

## 1. Damping cylinder

### Inspection

1. Inspect the inner tube for stone chips, scoring, scratches, excessive wear and any other damage. Renew as necessary.

#### Note:

- **Small inclusions in the inner tube may be removed using a fine grade stone or similar.**
2. Inspect the spring for damage, cracks and deformation. Renew the spring if necessary.
  3. Inspect all the bushes and seals for damage. Renew any damaged items if necessary.

### Assembly

#### **Warning**

The front forks comprise many precision machined parts. Total cleanliness must be observed at all times and assembly must take place in a dirt/dust-free environment.

Dirt ingress may cause damage to the fork parts, leading to incorrect operation, instability, loss of control or an accident.

#### Note:

- **If the damping cylinder has not been removed, omit steps 1 to 3.**

1. Fit the centering collar to the lower end of the damping cylinder.
2. Fit the damping cylinder to the inner tube.
3. Clean the threads of the damping cylinder bolt and fit a new sealing washer. Prevent the cylinder from turning while tightening the damping cylinder securing bolt to **20 Nm**.

#### Note:

- **To help with identification of the service tools, tool T3880158 has a single groove turned on its outside circumference. Tool T3880154 does not have a groove.**
4. Fit both halves of tool T3880158 (Tiger 800 models) or tool T3880154 (Tiger 800XC models) to the outer tube as shown below and hold in position.

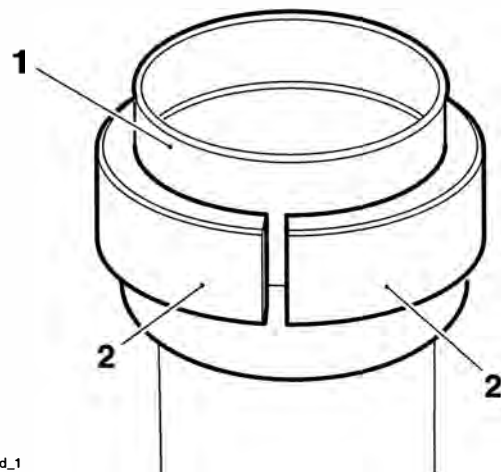

cgird\_1

**1. Outer tube**

**2. Tool T3880158 (Tiger 800) or T3880154 (Tiger 800XC)**



- Invert and position the fork tube outer to tool T3880153.

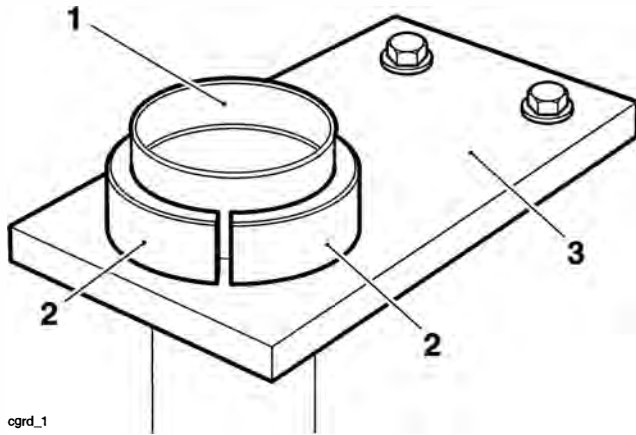

cgrd\_1

- Outer tube
- Tool T3880158 (Tiger 800) or T3880154 (Tiger 800XC)
- Tool T3880153

- Apply a smear of fork oil to the bushes and seals.
- Position the seals and bushes to the inner tube as noted prior to removal. Ensure the seal (item 3) is positioned with the text end facing the circlip. Use a new circlip.

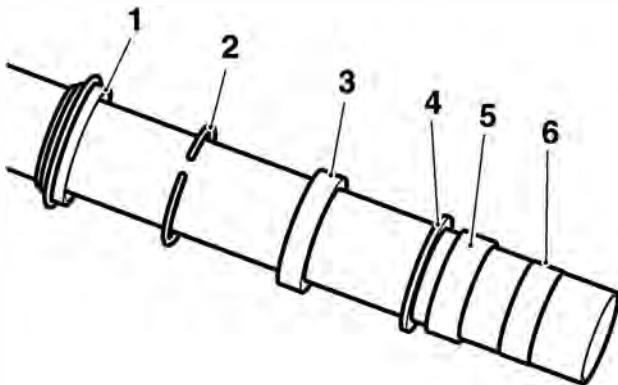

ccup\_2

- Dust seal
- Circlip
- Seal
- Washer
- Lower bush
- Upper bush
- Fit the upper bush to the fork inner tube.
- Position the inner tube assembly to the outer, ensuring that the oil and dust seal lips do not become damaged.

- Using the narrow end of tool T3880003 (Tiger 800 models) or T3880157 (Tiger 800XC models), guide the lower bush, washer and seal into place.

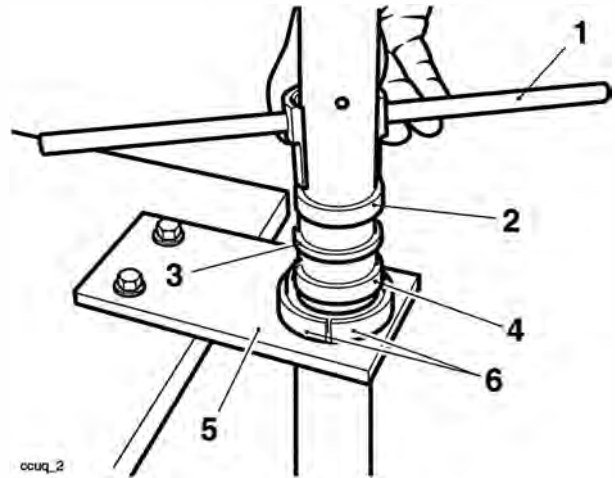

ccuq\_2

- Tool T3880003 (Tiger 800) or T3880157 (Tiger 800XC)
- Seal
- Washer
- Lower bush
- Tool T3880153
- Tool T3880158 (Tiger 800) or T3880154 (Tiger 800XC)
- Retain the bush, washer and seal with a new circlip.

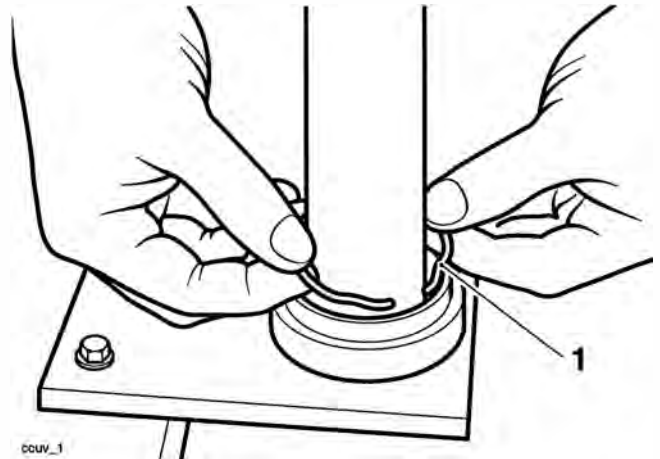

ccuv\_1

- Dust seal
- Circlip
- Tool T3880153
- Position the dust seal to the outer tube.
- Invert tool T3880003 (Tiger 800 models) or T3880157 (Tiger 800XC models) and, using hand pressure only, push the dust seal squarely into the outer tube.
- Fill the fork with oil (see page 13-7).
- Position the fork assembly as for compression of the fork spring during strip down.

# Front Suspension

## ! Caution

If removed, the damping rod locknut must be fitted with the flat face facing to the top of the fork. The slightly tapered face must face the fork spring. Incorrect orientation may lead to a loosening of the locknut.

16. **Tiger 800:** Re-thread the damper cylinder rod locknut leaving **10.5 mm** of thread exposed above the nut (dimension **A** below).
17. **Tiger 800XC:** Re-thread the damper cylinder rod locknut leaving **12 mm** of thread exposed above the nut (dimension **A** below).

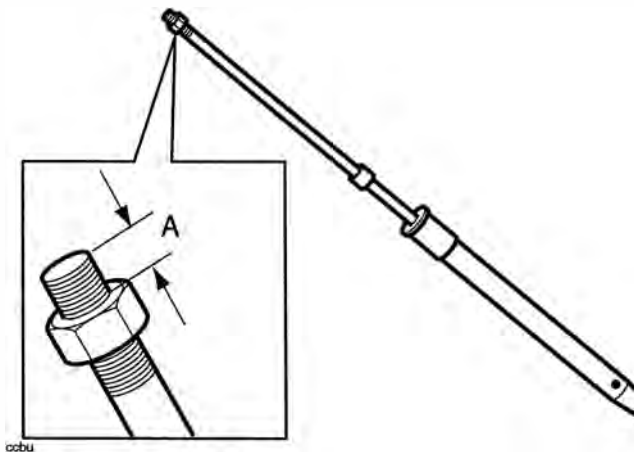

**Damper Cylinder Rod Nut Setting**

18. Refit the fork spring, close wound end uppermost, spring spacer and washer.

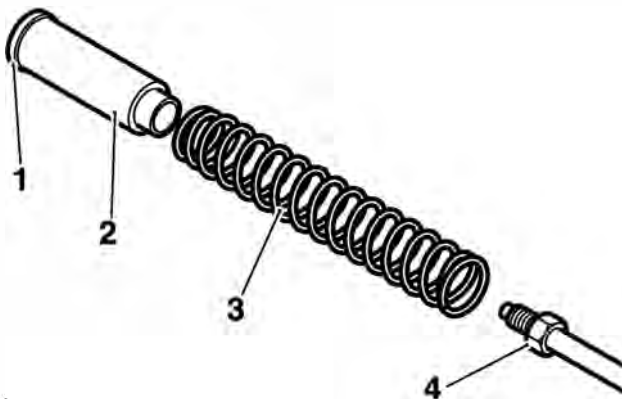

1. Washer
2. Spring spacer (Tiger 800 shown)
3. Spring
4. Damper rod

19. Attach tool 3880085-T0301 to the threads of the damper rod and pull the damper upwards.

## ! Warning

While compressing the fork spring always wear protective equipment for the face and eyes and never stand directly above or look directly down on the fork. If the spring compressor should dislodge or detach, the resulting release of spring tension could cause parts to fly off resulting in injury to the user.

20. **Tiger 800XC only:** Refit tool T3880067 as previously described, compress the fork spring and refit the split collar below the damper rod nut. Remove tool T3880067.

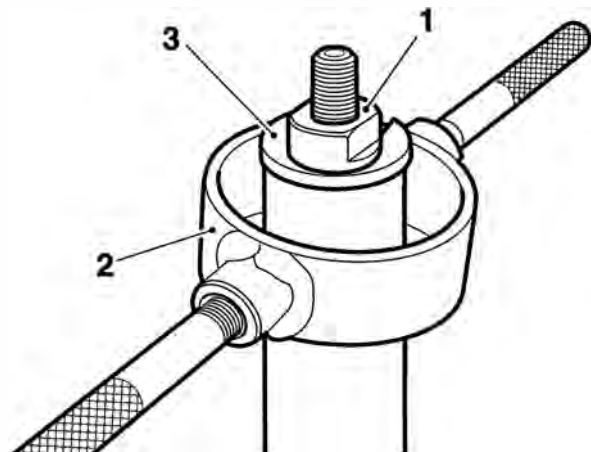

1. Damper locknut
2. Tool T3880067
3. Spring holder (part of T3880067)

### Note:

- On Tiger 800 models, an assistant may be required to install the split collar.

21. **Tiger 800 only:** Tool T3880067 is not required; the spring can be compressed by gripping the spring collar by hand and the split collar installed with the aid of an assistant.
22. Remove tool 3880085-T0301 from the damper rod.
23. Fit a new O-ring to the top cap.
24. Refit the top cap to the damper rod.
25. Hold the top cap while tightening the damper rod locknut to **20 Nm**.
26. Lubricate the O-ring on the top cap with a smear of fork oil then screw the top cap fully into the inner tube.
27. Tighten the top cap to **35 Nm**.

### Note:

- It is much easier to tighten the top cap when the fork has been refitted.

28. Refit the fork (see page 13-6).

## Headstock Bearing Check/ Adjustment

### Check

1. Raise and support the front of the motorcycle.

### Warning

Before starting work, ensure the motorcycle is stabilised and adequately supported. This will help prevent it from falling and causing injury to the operator or damage to the motorcycle.

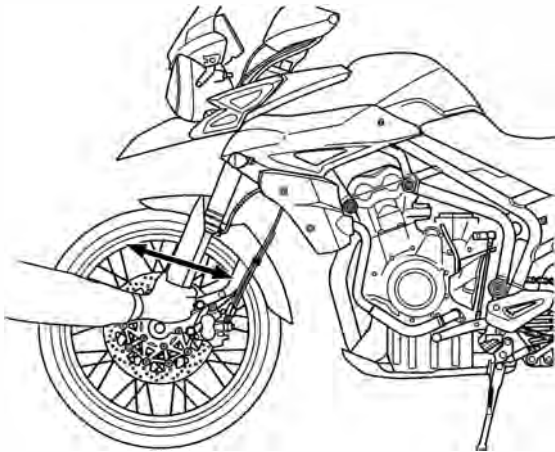

cgjt

### Checking Headstock Bearing Adjustment

2. Hold the lower end of the front forks as illustrated and 'rock' with a front-to-rear motion. If free play can be detected, the headstock bearings require adjustment.

### Adjustment

### Warning

Always return the handlebars and risers to their original position as noted in paragraph 1. Operating the motorcycle with a handlebar position that is unfamiliar may lead to loss of control or an accident.

1. Note the original position of the handlebars, and orientation of the adjustable risers, in order that they can be returned to the same position when the repair operation is complete.
2. Raise and support the front of the motorcycle.
3. Release the fixings securing the handlebar clamps to the risers, detach the clamps and release the handlebar.
4. As an assembly, raise the handle bars until clear of the top yoke. Rest the assembly forward of the steering stem such that access to the headstock top nut and the adjustment nuts is unrestricted. Ensure the master cylinder remains in an upright position.
5. Slacken the top yoke clamp bolts.

### Warning

If the lower yoke fixings are also slackened, the forks will no longer support the weight of the motorcycle.

Do not slacken the lower yoke fixings as, in this condition, the motorcycle could topple over causing damage and/or risk of injury.

### Caution

Care must be taken when removing the headstock top nut, to ensure that the top nut and top yoke do not become scratched. Protect the surfaces with a suitable cloth or tape to prevent scratching.

6. Slacken the headstock top nut.

# Front Suspension

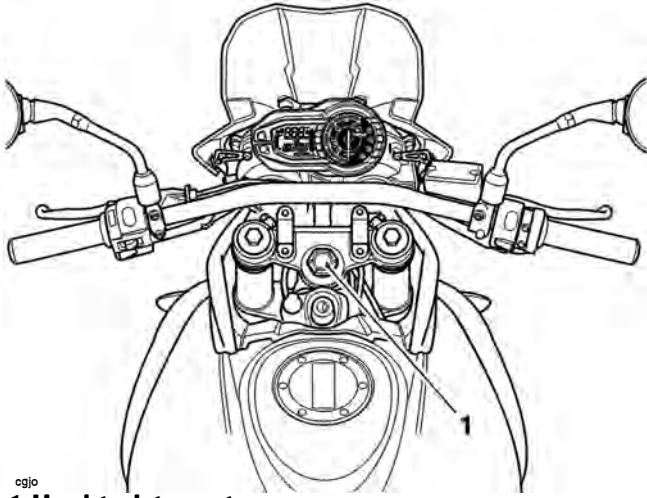

cgjo

## 1. Headstock top nut

7. Ease the top yoke from the forks and support while detached.

8. Adjust the bearing free-play as follows, all using tool T3880023:

- Remove the locknut and tab washer.
- Slacken the adjuster nut then tighten to **40 Nm**.
- Slacken the adjuster nut, then re-tighten to **15 Nm**.
- Fit the tab washer and lock nut.



## Warning

It is essential that the adjuster nut is not over-tightened. If the adjuster is over-tightened it will cause a pre-load on the headstock bearings. This will introduce tight steering, which could cause loss of control and an accident.

- Hold the adjuster nut in position while tightening the locknut to **40 Nm**.

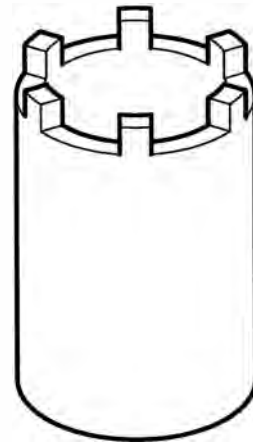

cdbp

Tool T3880023

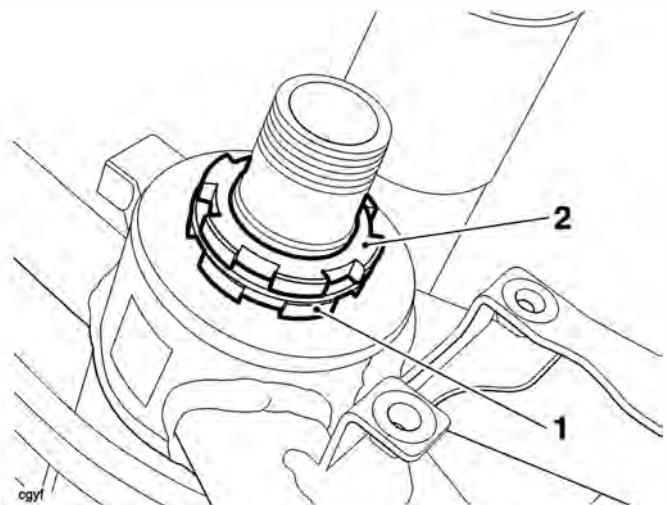

cgyl

1. Adjuster nut
2. Locknut

9. Refit the top yoke assembly to the forks.
10. Tighten the top nut to **90 Nm**.
11. Tighten the top yoke clamp bolts to **20 Nm**.
12. Locate the handlebar assembly in the lower halves of the clamps. Fit the upper clamps and 10 mm bolts.
13. Rotate the handlebar so that the etched centre (longer) marking on the handlebar aligns with the split line on the upper clamps/risers.
14. Tighten the 10 mm bolts to **35 Nm**.

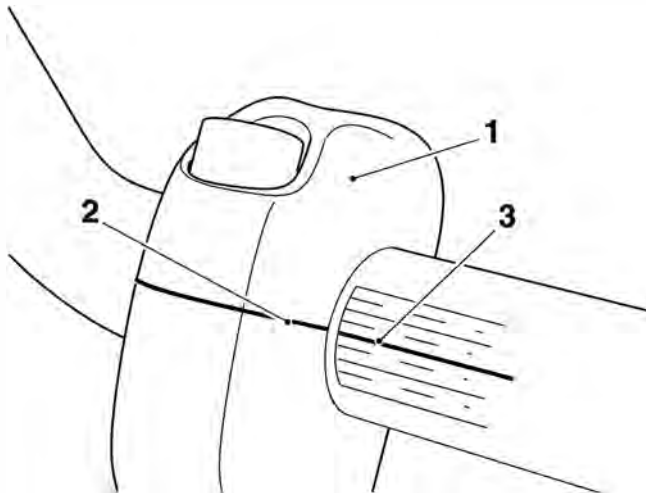

1. Upper clamp
2. Clamp split line
3. Centre marking

15. Refit the 8 mm bolts to the and tighten to **26 Nm**.
16. Recheck the bearing adjustment (see page 13-15).

## Headstock Bearing Removal



### Warning

Before starting work, ensure the motorcycle is stabilised and adequately supported. This will help to prevent it falling and causing injury to the operator or damage to the motorcycle.

1. Remove both forks (see page 13-5).



### Caution

Care must be taken when removing the headstock top nut, to ensure that the top nut and headstock do not become scratched. Protect the surfaces with a suitable cloth or tape to prevent scratching.

2. Remove the headstock top nut.

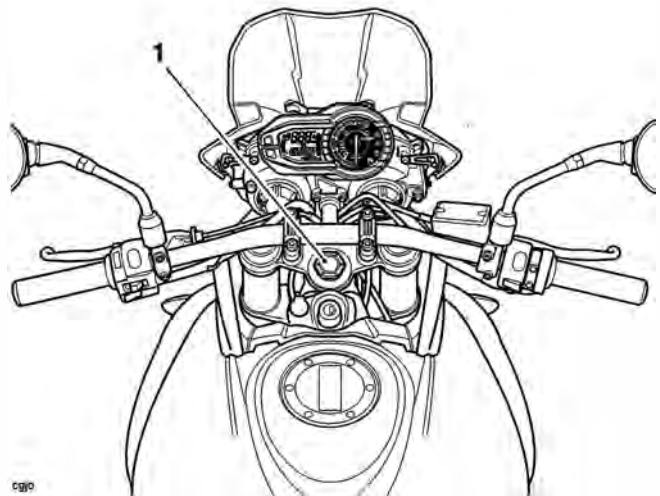

### 1. Headstock top nut

3. As an assembly, raise the top yoke and handle bars until clear of the steering stem. Rest the assembly forward of the steering stem such that access to the adjustment nuts is unrestricted. Ensure the master cylinder remains in an upright position.

## Front Suspension

- Using tool T3880023, remove the locknut and tab washer. Discard the tab washer.

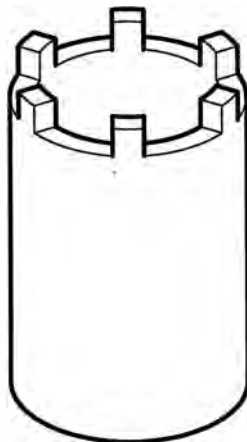

odbp

**Tool T3880023**

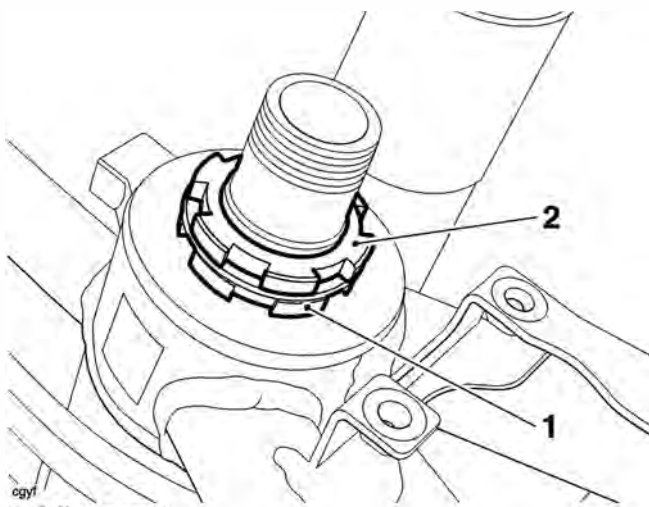

- ogyt
- Adjuster nut
  - Locknut

- Using the same tool, remove the adjuster nut.
- Remove the bearing cover and dust seal.
- Remove the bottom yoke from below the frame headstock.

### **Warning**

Always wear eye, hand and face protection when using a hammer and drift. Use of a hammer and drift can cause bearings to fragment. Pieces of fragmented bearing could cause eye and soft tissue injuries if suitable protective apparel is not worn.

- Using a suitable drift, evenly and progressively drive the bearing races from the frame headstock.
- Remove the inner race and dust seal from the bottom yoke using a press or puller.

### **Inspection**

#### **Warning**

Only remove raised witness marks from within the frame. Removal of material below any raised areas will reduce the level of interference between the frame and the bearings. Loss of interference could cause the bearing to become loose in the frame leading to loss of motorcycle control and an accident.

- Examine the frame for any raised witness marks caused by the removal process. Remove any such marks with fine emery paper or a gentle file.

## Installation

1. Fit a new dust seal to the steering stem on the bottom yoke.

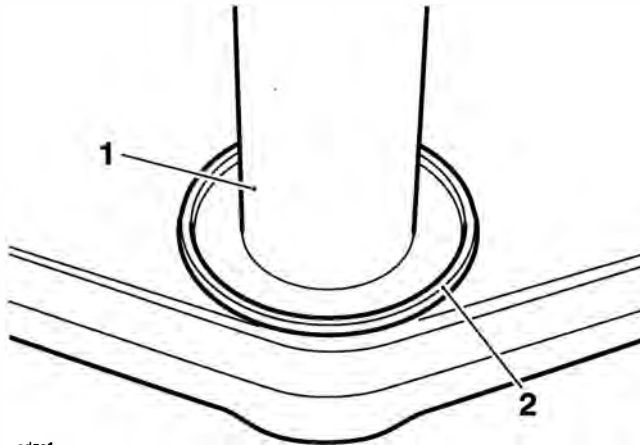

cdgo1

1. Steering stem
2. Dust shield

### ⚠ Caution

Protect the threads of the bottom yoke when using a press or puller as damaged threads may mean replacing the yoke completely.

2. Press a new lower bearing inner race onto the steering stem of the bottom yoke.

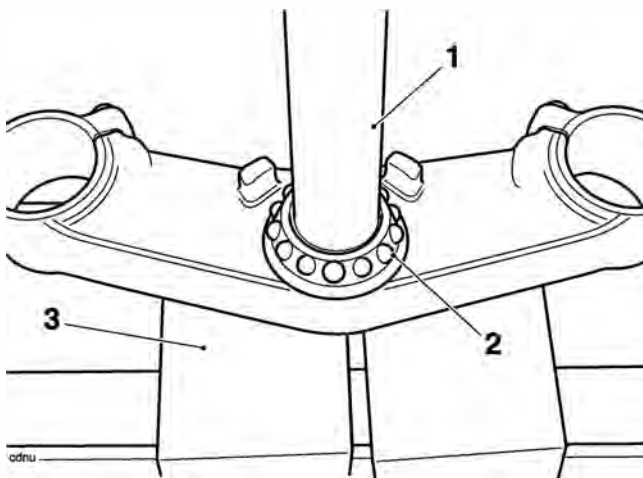

1. Bearing
2. Bottom yoke
3. Press bed

3. Evenly and progressively drive a new complete upper bearing into the frame headstock.
4. Lubricate the lower bearing using multi-purpose grease.
5. Drive a new lower outer bearing into the frame headstock.

6. Lubricate the upper bearing using multi-purpose grease.
7. Insert the lower yoke to the frame, fit the upper bearing and race.
8. Fit a new upper dust seal and bearing cover, and retain with the adjuster nut.
9. Adjust the headstock bearings (see page 13-15).
10. Locate the upper yoke to the steering stem. Install but do not fully tighten the headstock top nut at this stage.
11. Fit the forks (see page 13-6).
12. Tighten the headstock top nut to **90 Nm**.
13. Check that no freeplay exists in the headstock bearings. Adjust as necessary (see page 13-15).

# Front Suspension

## Handlebars

### Warning

Before starting work, ensure the motorcycle is stabilised and adequately supported. This will help prevent it from falling and causing injury to the operator or damage to the motorcycle.

## Removal

### Warning

Always return the handlebars and risers to their original position as noted in paragraph 1. Operating the motorcycle with a handlebar position that is unfamiliar may lead to loss of control or an accident.

1. Note the original position of the handlebars, and orientation of the adjustable risers, in order that they can be returned to the same position when the repair operation is complete.
2. Remove the rider's seat (see page 16-13) and disconnect the battery negative (black) lead first.
3. **Tiger 800 only:** Undo the fixing screws and remove the end weights from the handlebars.
4. **Tiger 800XC only:** Remove the fixings and remove the handguards. Discard the fixings.

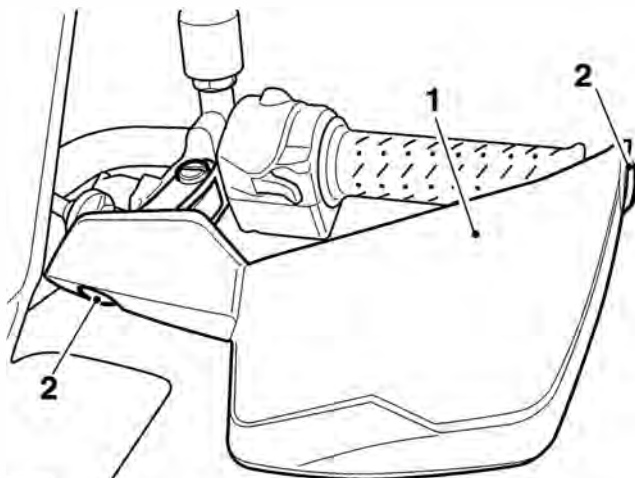

T0891

1. Handguard (left hand shown)
2. Fixings

5. Undo the screws and free the left switch gear assembly from the handlebar. Without disconnecting any wiring, lay the switch aside.
6. Unscrew the bolts and remove the clamp from the clutch lever assembly. Without disconnecting the clutch cable, lay the lever aside.

7. Slide off the rubber boot and release the screws which secure the two halves of the twist grip guide to each other.

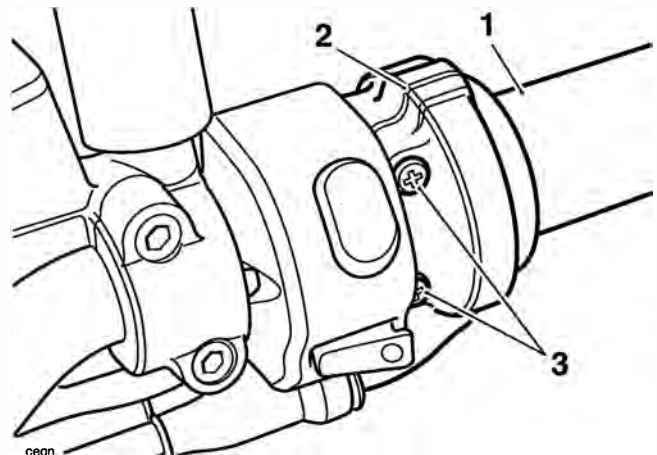

1. Twist grip
2. Twist grip guide
3. Screws

8. Note the position of the guide relative to the handlebar then separate the two halves of the twist grip guide.
9. Note and mark the position of each cable relative to the twist grip in order to correctly identify their location during reassembly.
10. Release the inner cables from the twist grip.

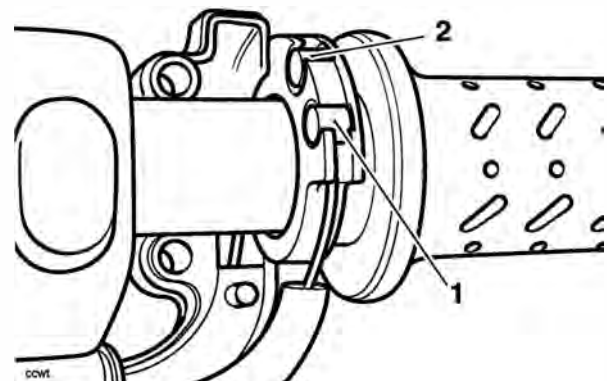

1. Closing inner cable
2. Opening inner cable

11. Slide the twist grip off the handlebar.
12. Undo the screws and free the right hand switch gear assembly from the handlebar. Without disconnecting any wiring, lay the switch aside.
13. Unscrew the bolts and remove the clamp from the front brake master cylinder. Taking care to not invert the brake fluid reservoir, lay the assembly aside.



14. Release the fixings securing the handlebar clamps to the risers, detach the clamps and collect the handlebar.

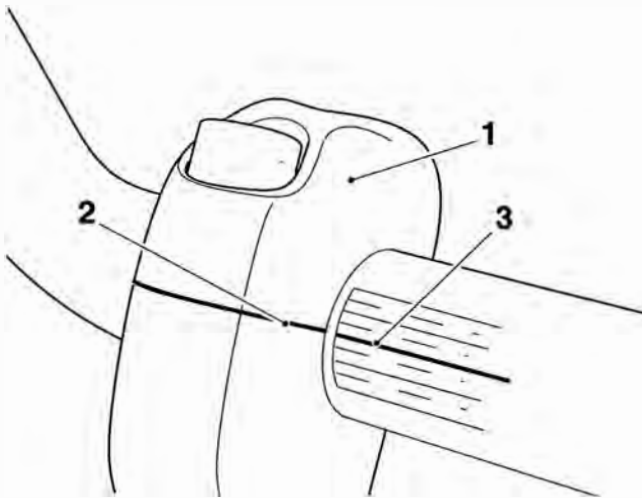

1. Upper Clamp
2. Handlebar
3. Riser

15. If required, remove the left hand handlebar grip.

## Installation

1. Locate the handlebar assembly in the lower halves of the clamps. Fit the upper clamps and 10 mm bolts.
2. Rotate the handlebar so that the etched centre (longer) marking on the handlebar aligns with the split line on the upper clamps/risers.
3. Tighten the 10 mm bolts to **35 Nm**.

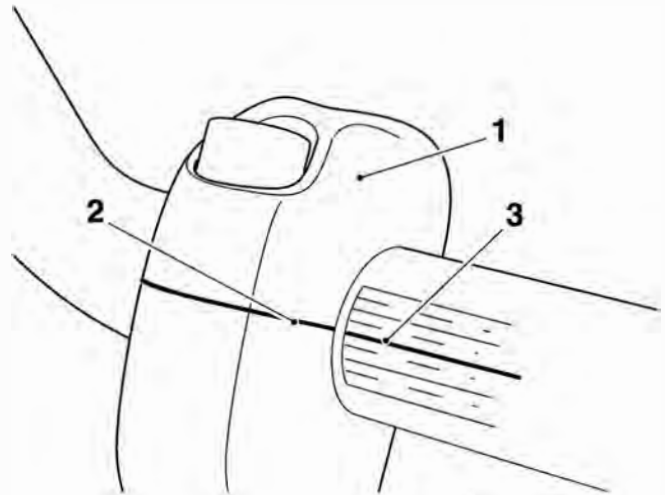

1. Upper clamp
2. Clamp split line
3. Centre marking

4. Refit the 8 mm bolts and tighten to **26 Nm**.
5. Fit the left hand handlebar grip.
6. Position the clutch lever to the handlebar. Fit the clamp (UP arrow pointing upwards) and clamp bolts.
7. Align the split line of the clutch lever with the '+' mark on the upper surface of the handlebar, then tighten the clamp bolts, upper first, to **12 Nm**.
8. Align the left hand switch cube to the handlebar and secure with the screws. Tighten the screws to **3 Nm**.
9. Slide the twist grip onto the right hand side of the handlebar.

## Front Suspension

10. Reconnect the inner throttle cables as noted during removal. Ensure that the positions of the opening and closing cables are not transposed.

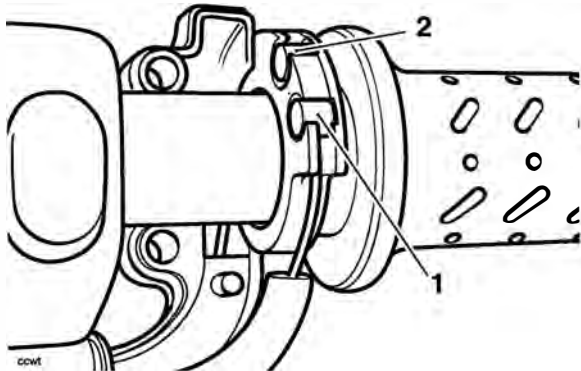

1. Closing inner cable
2. Opening inner cable

11. Assemble the two halves of the cable guide ensuring that the outer cables are correctly located in the guide and the guide is positioned on the handlebars as prior to removal.

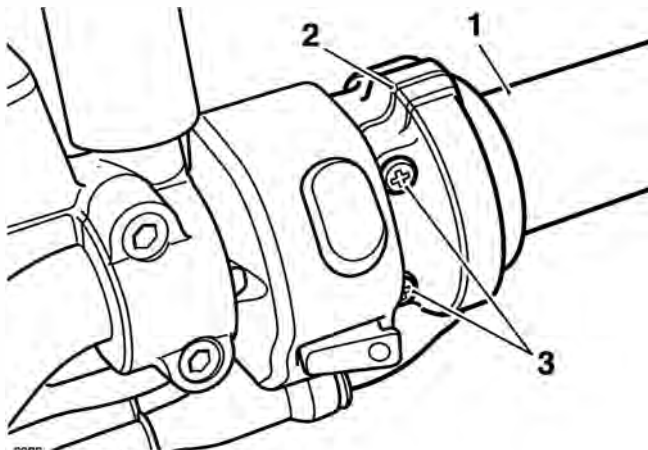

1. Twist grip
2. Twist grip guide
3. Screws

12. Tighten the cable guide fixings to **3 Nm**.
13. Position the right hand switch cube to the handlebar and tighten the fixings to **3 Nm**.
14. Position the front brake master cylinder assembly to the handlebar. Fit the clamp (Up arrow pointing upwards) and clamp fixings.
15. Align the split line of the master cylinder clamp to the '+' mark on the upper surface of the handlebar and tighten the clamp fixings to **12 Nm**.

16. **Tiger 800 only:** Fit the handlebar end weights, tightening the fixings to **5 Nm**.
17. **Tiger 800XC only:** Position the handguards to the handlebar and secure with the two fixings, using new fixings at the handguard to spacer position. Tighten the handguard to spacer fixing to **6 Nm** and the handguard to bracket fixing to **9 Nm**.
18. Check the throttle cable free play setting. Adjust as necessary (see page 10-104).
19. Reconnect the battery, positive (red) lead first.
20. Refit the seats.
21. Check for correct operation of the front brake and clutch. Check that the throttle opens and closes without sticking and that the cables do not bind or restrict the steering when the handlebars are turned from lock-to-lock. Rectify as necessary.

### Warning

Operation of the motorcycle with incorrectly adjusted, incorrectly routed or damaged throttle cables could interfere with the operation of the brakes, clutch or the throttle itself. Any of these conditions could result in loss of control of the motorcycle and an accident.

### Warning

Move the handlebars to left and right full lock while checking that cables and harnesses do not bind or that the steering feels tight or difficult to turn. A cable or harness that binds, or steering that is tight/difficult to turn will restrict the steering and may cause loss of control and an accident.

# 14 Brakes

## Table of Contents

Exploded View - Front Brake Master Cylinder - Tiger 800 .....	14.4
Exploded View - Front Brake Master Cylinder - Tiger 800 XC .....	14.5
Exploded View - Front Brake Caliper .....	14.6
Exploded View - Rear Brake Master Cylinder .....	14.7
Exploded View - Rear Brake Caliper .....	14.8
Exploded View - ABS System .....	14.9
Braking System Maintenance Safety Precautions .....	14.10
Front Brake Fluid Level Inspection .....	14.10
Rear Brake Fluid Level Inspection .....	14.11
Changing Brake Fluid .....	14.12
Brake Pads .....	14.12
Brake Wear Inspection .....	14.12
Breaking-in New Brake Pads and Discs .....	14.12
Bleeding the Front Brakes, Renewing Brake Fluid .....	14.12
Front Brake Pads .....	14.14
Removal .....	14.14
Inspection .....	14.15
Installation .....	14.15
Front Brake Caliper .....	14.16
Removal .....	14.16
Disassembly .....	14.17
Installation .....	14.18
Front Discs .....	14.19
Wear .....	14.19
Removal .....	14.19
Installation .....	14.20
Front Brake Master Cylinder .....	14.20
Removal .....	14.20
Disassembly .....	14.21
Inspection .....	14.21
Assembly .....	14.22
Installation .....	14.22

# Brakes

---

Bleeding the Rear Brakes, Renewing Brake Fluid .....	14.23
Rear Brake Pads .....	14.25
Installation .....	14.26
Rear Brake Caliper .....	14.27
Removal .....	14.27
Disassembly .....	14.27
Inspection .....	14.27
Assembly .....	14.28
Installation .....	14.29
Rear Brake Disc .....	14.30
Wear .....	14.30
Rear Master Cylinder .....	14.30
Removal .....	14.30
Disassembly .....	14.31
Inspection .....	14.31
Assembly .....	14.31
Installation .....	14.32
Bleeding the Front Brakes - Motorcycles with ABS .....	14.33
Front ABS Wheel Sensor .....	14.34
Removal .....	14.34
Installation .....	14.34
Front ABS Pulser Ring .....	14.35
Removal .....	14.35
Inspection .....	14.35
Installation .....	14.35
Bleeding the Rear Brake Fluid - Motorcycles with ABS .....	14.36
Rear ABS Wheel Speed Sensor .....	14.37
Removal .....	14.37
Installation .....	14.37
Rear ABS Pulser Ring .....	14.38
Removal .....	14.38
Inspection .....	14.38
Installation .....	14.38
Air Gap Measurement - Front and Rear Wheel Speed Sensors .....	14.38
ABS Hydraulic Modulator/ECM .....	14.39
Removal .....	14.39
Installation .....	14.42
ABS .....	14.44
System Description .....	14.44
Component Location .....	14.45
ABS System Circuit Diagram .....	14.46
Key to Wiring Diagram .....	14.46
ABS System Circuit Diagram .....	14.47
System Diagnostics .....	14.48

Diagnostic Tool Connection .....	14.49
Triumph Diagnostic Tool .....	14.50
Build Data .....	14.50
Current Data .....	14.50
Bleed System .....	14.50
Diagnostic Trouble Codes .....	14.50
Diagnostic Trouble Codes .....	14.52
Electrical Connectors .....	14.54
Before Disconnection: .....	14.54
When Disconnecting a Connector: .....	14.54
When Inspecting a Connector: .....	14.54
When Connecting a Connector: .....	14.54
Disconnection of ABS ECM Connector .....	14.55
Reconnection of ABS ECM Connector .....	14.56
Further Diagnosis .....	14.57
ABS Warning Light ON (No DTCs Stored) .....	14.58
ABS Warning Light Does Not Illuminate (No DTCs Stored) .....	14.59
Front Wheel Sensor Open Circuit/Short Circuit .....	14.61
Rear Wheel Sensor Open Circuit/Short Circuit .....	14.63
Front Wheel Sensor Abnormal Input/losing Contact .....	14.65
Rear Wheel Sensor Abnormal Input/Losing Contact .....	14.66
Front Wheel Pulser Gear Missing Teeth .....	14.67
Rear Wheel Pulser Gear Missing Teeth .....	14.68
Front or Rear Input/Output Solenoid Open/Short Circuit .....	14.69
Front or Rear Wheel Actuator (Hydraulic Control) Wheel Lock .....	14.70
Motor - Lock; Motor Stuck OFF; Motor Stuck ON .....	14.71
Power Source Voltage Drop/Voltage Rise .....	14.72
Different Tyre Diameter .....	14.73
Abnormal ECU .....	14.74
ABS Hydraulic Circuit Layout .....	14.75

# Brakes

## Exploded View - Front Brake Master Cylinder - Tiger 800

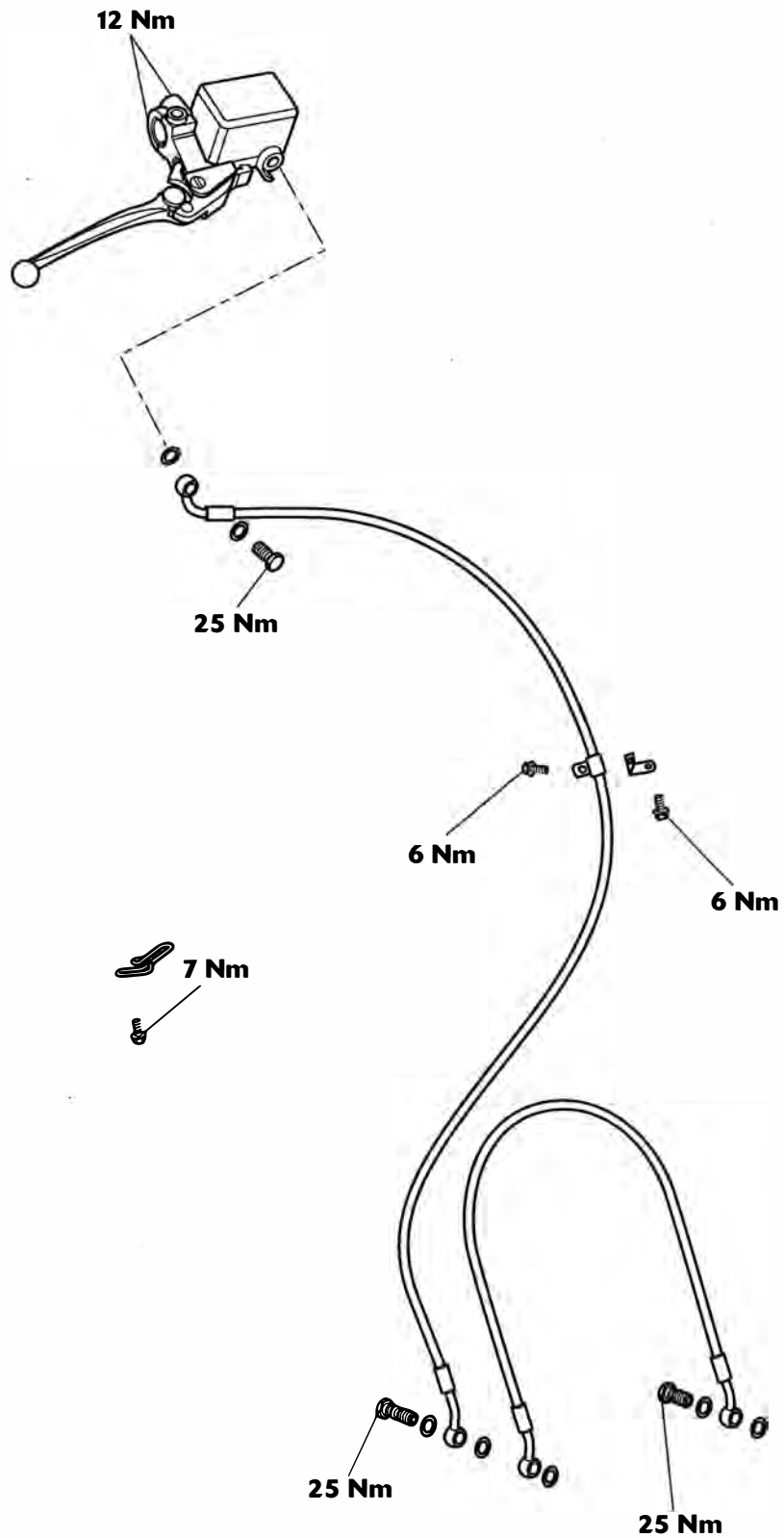

Exploded View - Front Brake Master Cylinder - Tiger 800XC

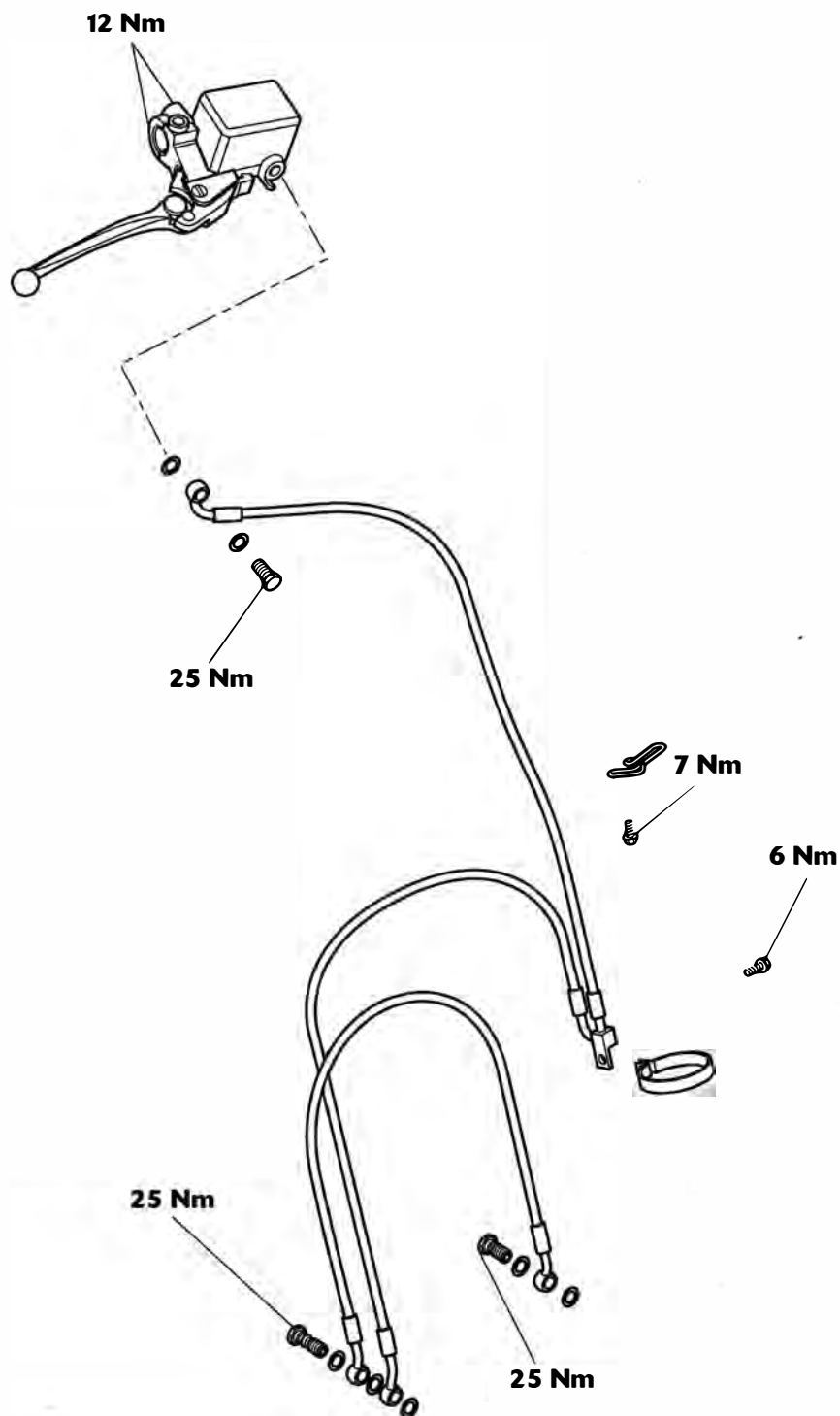

# Brakes

## Exploded View - Front Brake Caliper

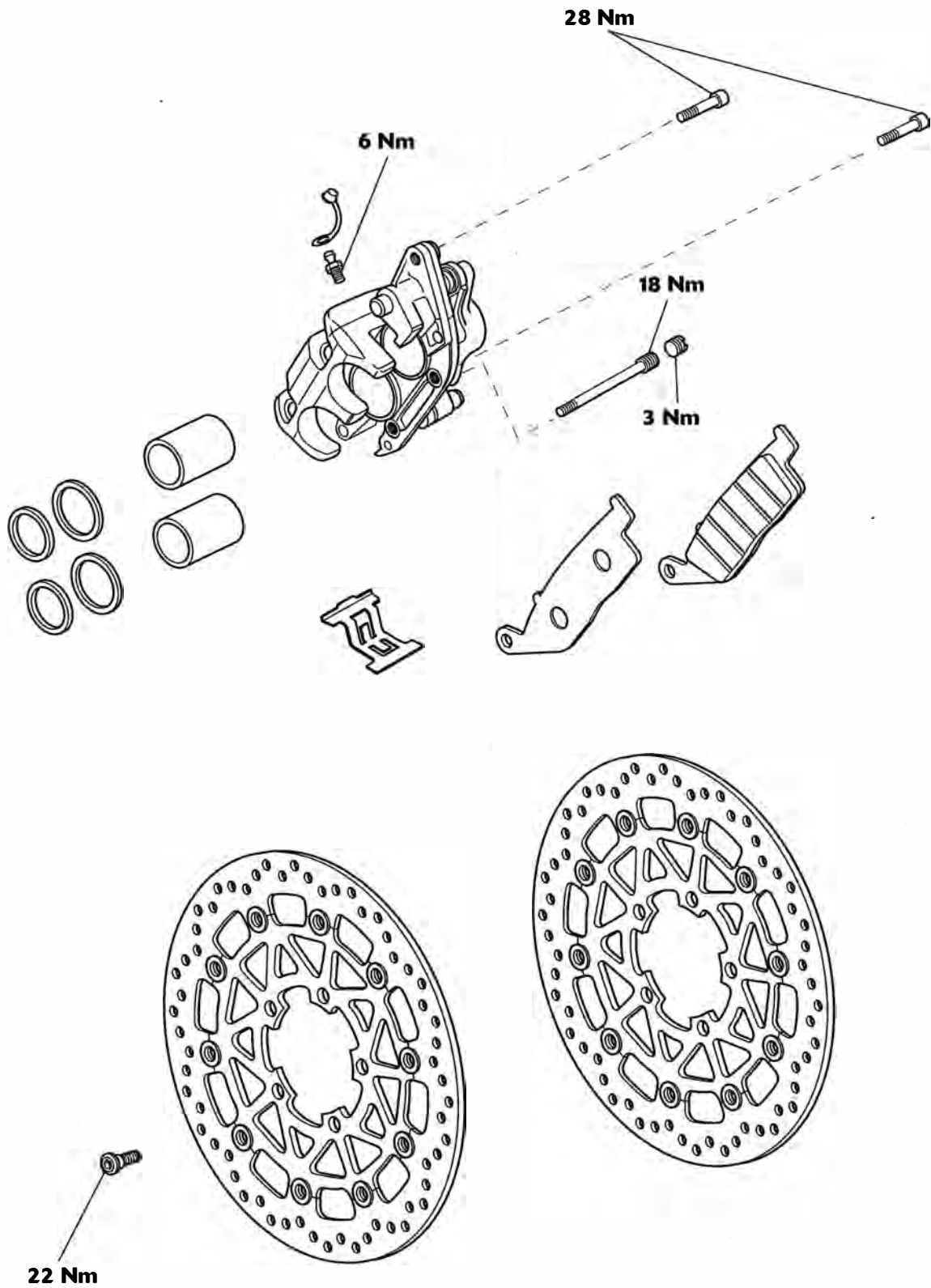



Exploded View - Rear Brake Master Cylinder

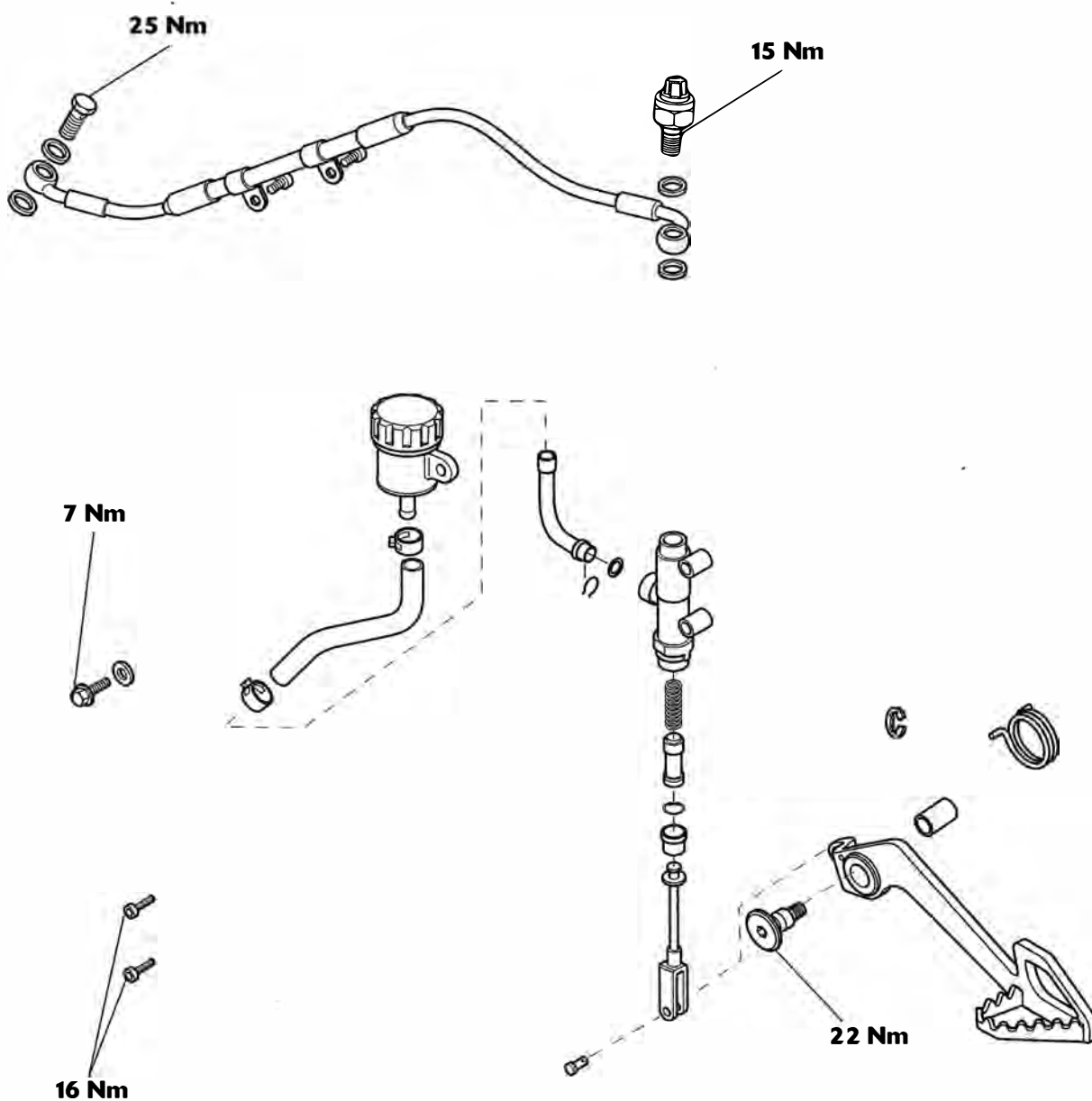

# Brakes

## Exploded View - Rear Brake Caliper

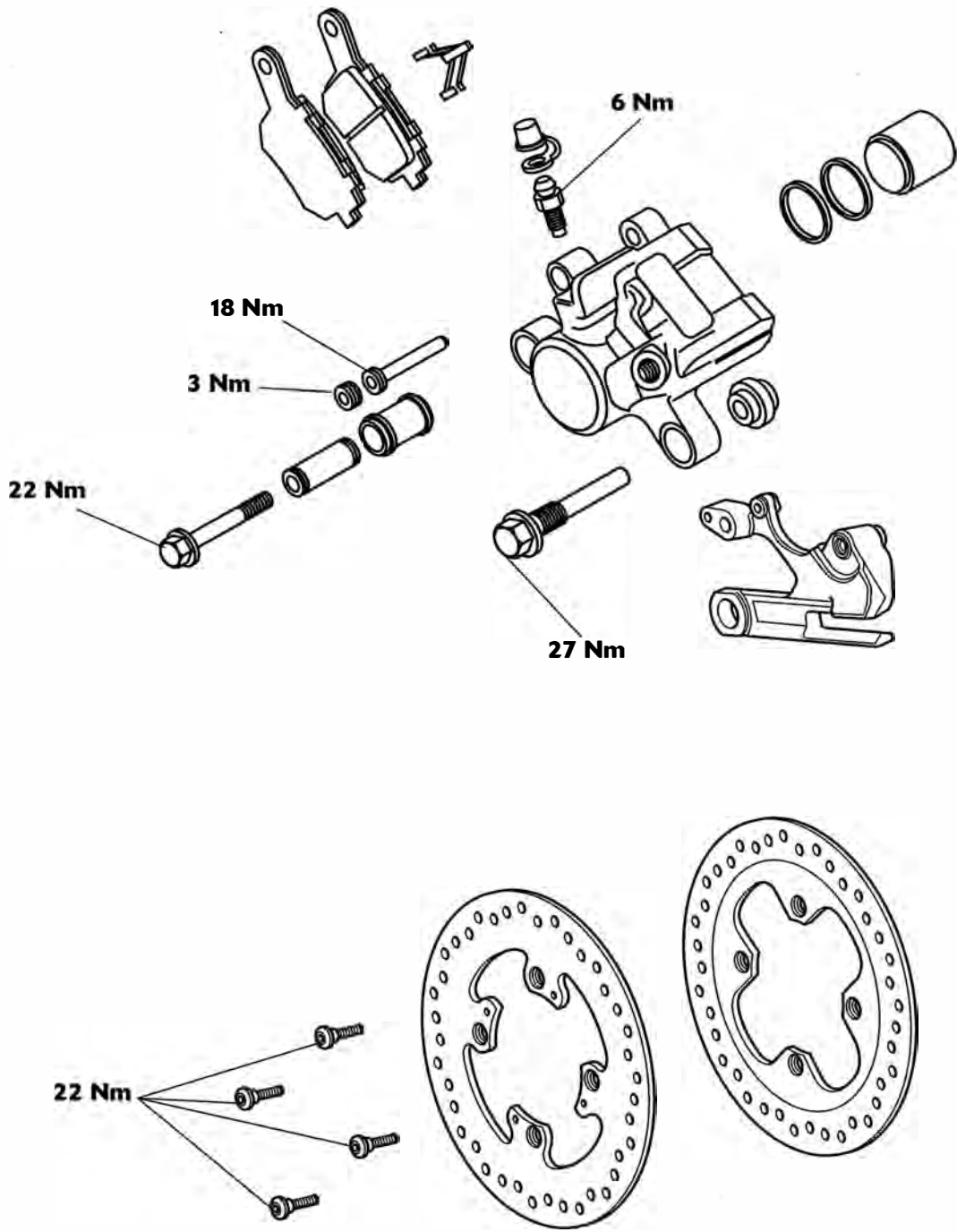

Exploded View - ABS System

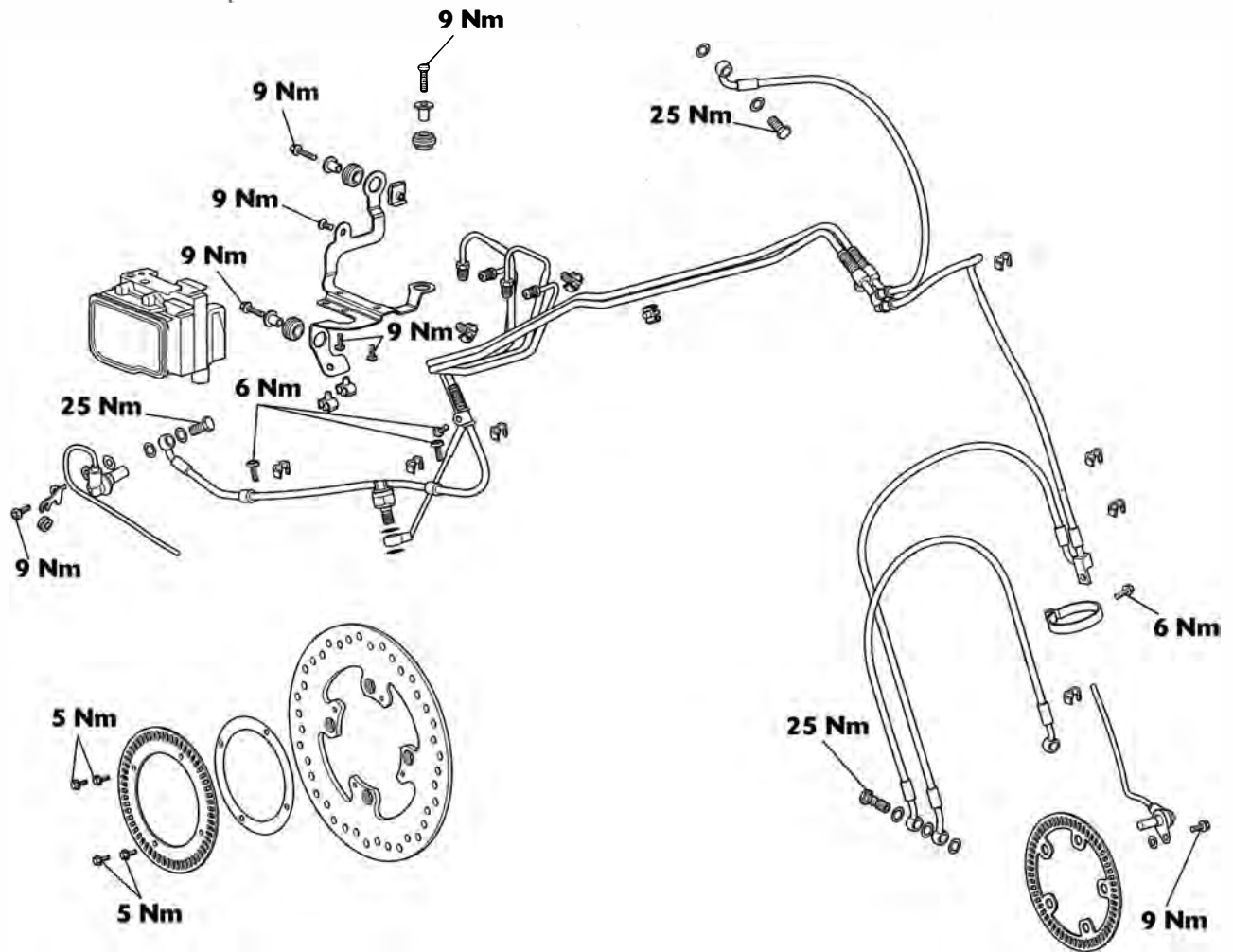

## Brakes

### Braking System Maintenance Safety Precautions

#### Warning

Brake fluid is hygroscopic which means it will absorb moisture from the air. The absorbed moisture will greatly reduce the boiling point of the brake fluid causing a reduction in braking efficiency.

Replace brake fluid in line with the scheduled maintenance chart. A dangerous riding condition could result if this important maintenance item is neglected.

Do not spill brake fluid onto any area of the bodywork as this will damage any painted or plastic surface.

Always use new brake fluid from a sealed container and never use fluid from an unsealed container or from one which has been previously opened.

Do not mix different brands of fluid. Check for fluid leakage around brake fittings, seals and joints.

Check regularly for brake hose damage.

**FAILURE TO OBSERVE ANY OF THE ABOVE WARNINGS MAY REDUCE BRAKING EFFICIENCY LEADING TO AN ACCIDENT.**

#### Warning

If there has been an appreciable drop in the level of the fluid in either brake fluid reservoir, consult your authorised Triumph dealer for advice before riding.

If the brake lever or pedal feels soft when it is applied, or if the lever/pedal travel becomes excessive, there may be air in the brake lines or the brake may be defective.

It is dangerous to operate the motorcycle under such conditions and remedial action must be taken by your authorised Triumph dealer before riding the motorcycle. Failure to take remedial action may reduce braking efficiency leading to an accident.

#### Warning

Use only DOT 4 specification brake fluid as listed in the general information section of this manual. The use of brake fluids other than those DOT 4 fluids listed in the general information section may reduce the efficiency of the braking system leading to an accident.

Failure to change the brake fluid at the interval specified in the scheduled maintenance chart may reduce braking efficiency resulting in an accident.

#### Warning

Never use mineral based grease (such as lithium or copper based grease) in any area where contact with the braking system hydraulic seals and dust seals is possible. Mineral based grease will damage the hydraulic seals and dust seals in the calipers and master cylinders. Damage caused by contact with mineral based grease may reduce braking efficiency resulting in an accident.

## Front Brake Fluid Level Inspection

### Warning

Before starting work, ensure the motorcycle is stabilised and adequately supported. This will help prevent it from falling and causing injury to the operator or damage to the motorcycle.

In accordance with the scheduled maintenance chart, inspect the brake fluid level in the front and rear master cylinder reservoirs.

1. Ensure that the brake fluid level in the front brake fluid reservoir is between the upper and lower level lines (reservoir held horizontal).

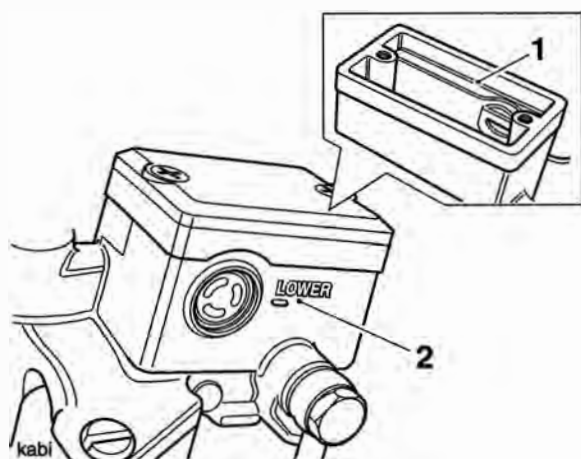

- 1. Front reservoir upper level**
- 2. Front reservoir lower level**

2. To inspect the fluid level, check the level of fluid visible in the window at the front of the reservoir body.
3. To adjust the fluid level:
  - Release the cap screws and detach the cover noting the position of the sealing diaphragm.
  - Fill the reservoir to the upper level line using new DOT 4 fluid from a sealed container.
  - Refit the cover, ensuring that the diaphragm seal is correctly positioned between the cap and reservoir body. Tighten the cap retaining screws.

## Rear Brake Fluid Level Inspection

### Warning

Before starting work, ensure the motorcycle is stabilised and adequately supported. This will help prevent it from falling and causing injury to the operator or damage to the motorcycle.

In accordance with the scheduled maintenance chart, inspect the brake fluid level in the front and rear master cylinder reservoirs.

1. Ensure that the brake fluid level in the rear brake fluid reservoir is between the upper and lower level lines (reservoir held horizontal).

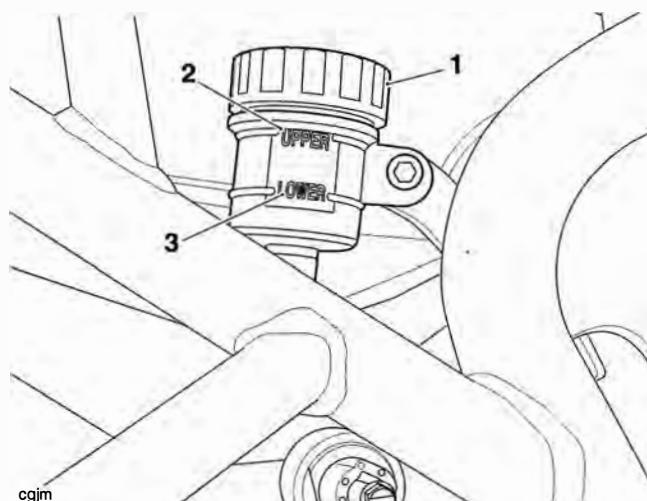

- 1. Rear brake fluid reservoir**
- 2. Rear reservoir upper level**
- 3. Rear reservoir lower level**

# Brakes

## Changing Brake Fluid

Brake fluid should be changed at the interval specified in the scheduled maintenance chart.

## Brake Pads

Front and rear pad wear is automatically compensated for and has no effect on brake lever or pedal action.

## Brake Wear Inspection

In accordance with the scheduled maintenance chart, inspect the brake pads for wear. The minimum thickness of lining material for any front or rear brake pad is **1.5 mm**. If any pad has worn to the bottom of the groove in the pad centre, replace all the brake pads on that wheel.

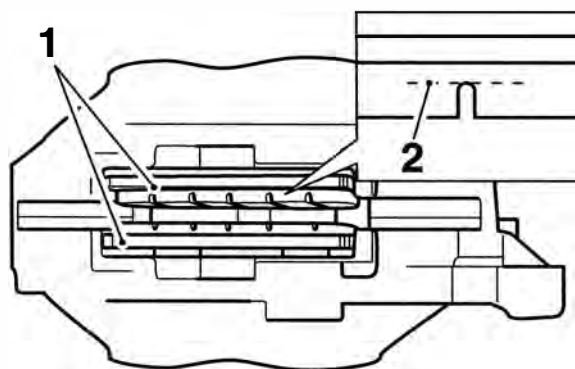

cbmz

1. Lining material thickness
2. Minimum thickness line

### Warning

Do not replace individual brake pads, replace both pads in the brake caliper. On the front where two calipers are mounted on the same wheel, all the pads in both calipers must be replaced together. Replacing individual pads will reduce braking efficiency and may cause an accident.

## Breaking-in New Brake Pads and Discs

After replacement brake discs and/or pads have been fitted to the motorcycle, we recommend a period of careful breaking-in that will optimise the performance and longevity of the discs and pads. The recommended distance for breaking-in new pads and discs is 200 miles (300 km).

## Bleeding the Front Brakes, Renewing Brake Fluid

### Warning

Before starting work, ensure the motorcycle is stabilised and adequately supported. This will help prevent it from falling and causing injury to the operator or damage to the motorcycle.

1. Note the original setting of the brake lever adjuster in order that it can be returned to the same position when the bleeding operation is complete. Set the brake lever adjuster to position No.1.

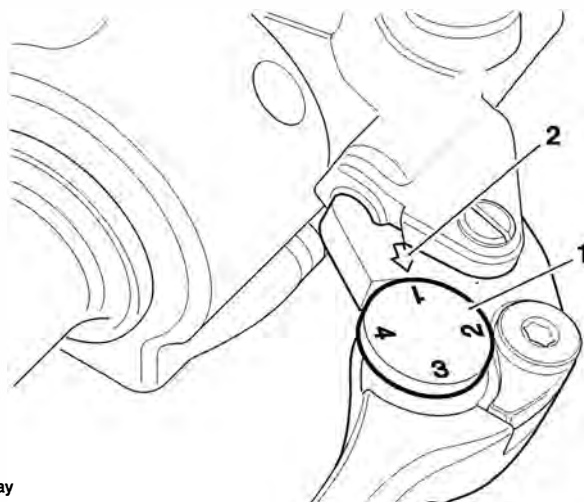

jaay

1. Adjuster wheel
  2. Triangular mark
2. Turn the handlebars to bring the fluid reservoir to a level position.

### Warning

Ensure absolute cleanliness when adding brake fluid to the brake fluid reservoir. Do not allow moisture or debris to enter the cylinder, as this will adversely affect the fluid properties. Always use fluid from a sealed container and do not use fluid from a container that has been opened for any period of time. Always check for fluid leakage around hydraulic fittings and for damage to hoses. A dangerous riding condition leading to loss of motorcycle control and an accident could result if this warning is ignored.

### Caution

To prevent paint damage, do not spill brake fluid onto any area of the bodywork. Spilled brake fluid will damage paintwork.

3. Release the cap screws and detach the cover noting the position of the sealing diaphragm.
4. Check the condition of the sealing diaphragm for the reservoir. Replace if necessary.
5. Remove the rubber cap from the bleed nipple on the right hand caliper.
6. Attach a transparent tube to the bleed nipple and place the other end of the tube in a suitable receptacle containing new brake fluid. Keep the tube end below the level of fluid.

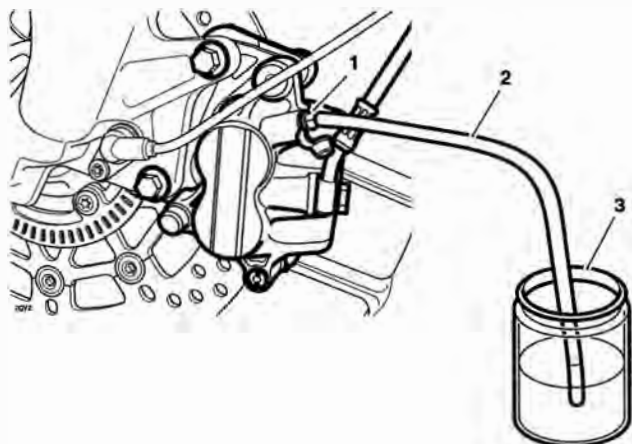

1. Bleed nipple
2. Bleed tube
3. Container

7. Release the bleed nipple.

**Note:**

- **During bleeding, do not allow the fluid level to fall below the lower level mark in the reservoir. If the fluid level is allowed to fall below this mark, air may enter the system and the sequence of bleeding must be repeated.**

8. Get an assistant to slowly pull the brake lever to the handlebar.
9. With the lever held fully against the handlebar, close the bleed nipple. Once the bleed nipple is closed, release the brake lever.
10. Repeat steps 10 and 11 until no more air appears in the bleed tube.
11. When all air has been expelled from the system, hold the lever fully against the handlebar and close the bleed nipple.

**Note:**

- **Maintain the brake fluid level between the upper and lower reservoir levels whilst bleeding is being carried out.**

12. Tighten the bleed nipple to **6 Nm**.
13. Remove the bleed tube.

14. Replace the bleed nipple cap.
15. Fill the reservoir to the upper level with new DOT 4 fluid.

## Warning

Use only DOT 4 specification brake fluid as listed in the general information section of this manual. The use of brake fluids other than those DOT 4 fluids listed in the general information section may reduce the efficiency of the braking system leading to loss of motorcycle control and an accident.

Observe the brake fluid handling warnings given earlier in this section of the manual.

## Caution

To prevent paint damage, do not spill brake fluid onto any area of the bodywork. Spilled brake fluid will damage paintwork.

16. Repeat the bleed procedure for the left hand caliper.
17. When both calipers have been bled, ensure the brake lever operation has a firm resistive feel to it, does not feel spongy and that the lever cannot be pulled directly back to the handlebar. Take remedial action as necessary.
18. Refit the diaphragm and reservoir cover. Refit the screws and tighten to **1.5 Nm**.

## Warning

Always return the lever adjuster to the original setting as noted in paragraph 1. Operating the motorcycle with lever settings that are unfamiliar may lead to loss of control or an accident.

19. Reset the brake lever adjuster to the original setting.
20. Check the operation of the front brake. Rectify as necessary.

## Warning

It is dangerous to operate the motorcycle with defective brakes; you must have your authorised Triumph dealer take remedial action before you attempt to ride the motorcycle again. Failure to take remedial action may reduce braking efficiency leading to loss of motorcycle control and an accident.

# Brakes

## Front Brake Pads

### Removal

#### Warning

Before starting work, ensure the motorcycle is stabilised and adequately supported. This will help prevent it from falling and causing injury to the operator or damage to the motorcycle.

1. Unscrew the pad retaining pin plug from the caliper.

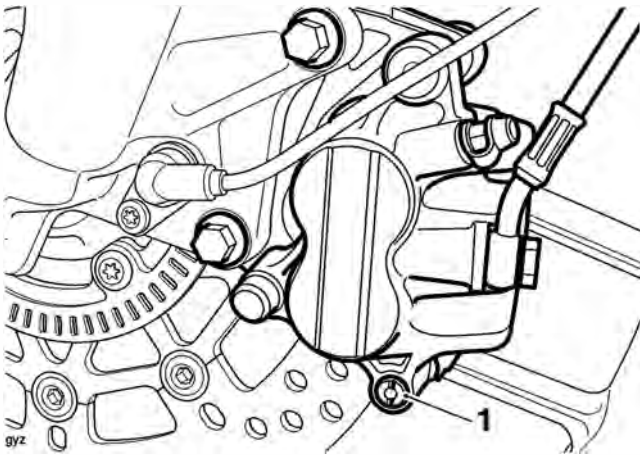

#### 1. Pad retaining pin plug

2. Loosen the pad retaining pin.

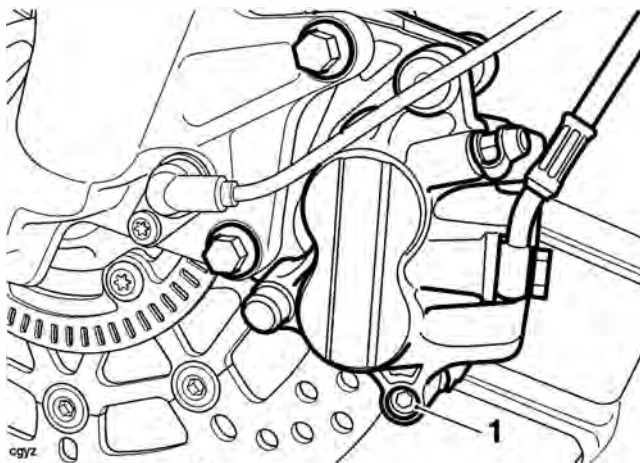

#### 1. Pad retaining pin

#### Warning

Do not allow the calipers to hang on the brake hoses as this may damage the hoses and could lead to loss of motorcycle control and an accident.

3. Slacken and remove the caliper mounting bolts and slide the caliper off the disc.

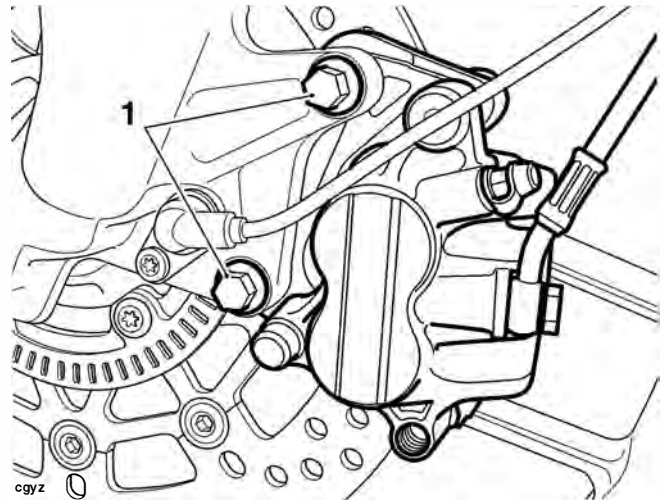

#### 1. Caliper fixings

4. Remove the pad retaining pin and remove the pads from the caliper. Take care not to lose the pad retainer from the mounting bracket or the anti-rattle spring from the caliper body.

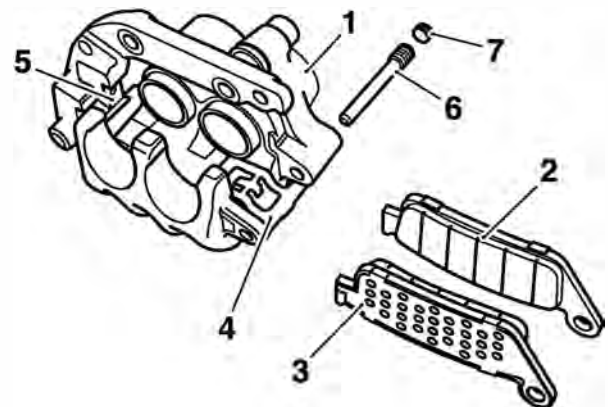

ceqv

1. Caliper
2. Brake pad
3. Heat isolation pad
4. Anti-rattle spring
5. Pad retainer
6. Pad retaining pin
7. Pad retaining pin plug



## Inspection

1. Check the pad retainer, anti-rattle spring and retaining pin. Renew any component which shows signs of damage or corrosion.
2. Check the caliper body slides easily on the mounting bracket pins and check there is no sign of leakage from the piston seals. Rectify any problems before installing the pads.

### Note:

- **Complete the assembly of the brake pads to one caliper (see assembly for details) before removing the pads from the other caliper.**

## Installation

### Warning

Never use mineral based grease (such as lithium or copper based grease) in any area where contact with the braking system hydraulic seals and dust seals is possible. Mineral based grease will damage the hydraulic seals and dust seals in the calipers and master cylinders. Damage caused by contact with mineral based grease may reduce braking efficiency resulting in an accident.

### Caution

Never lever directly against the disc, caliper or the pad lining material as this will damage these components. Always use a levering tool made from a soft material which will not cause damage to the load bearing surfaces.

Brake fluid will be displaced as the caliper pistons are compressed. To prevent body damage, ensure that the displaced fluid does not come into contact with any part of the bodywork.

1. If new pads are being installed, push the pistons fully back into the caliper body. Keep an eye on the fluid level in the reservoir whilst retracting the pistons to prevent fluid spillage.
2. Ensure the pad retainer is correctly fitted to the mounting bracket and the anti-rattle spring is securely clipped onto the caliper body.

### Warning

Do not apply more than a minimum coating of grease to the pad retaining pins. Excess grease may contaminate the brake pads, hydraulic seals and discs causing reduced braking efficiency and an accident.

3. Lubricate the pad retaining pin with a thin smear of proprietary high temperature copper based grease.
4. Ensure the heat isolation pads are fitted to the back of each brake pad. Fit the pads to the caliper with their friction material surfaces facing each other. Locate the pad upper ends in the mounting bracket retainer then align them with the caliper body and insert the retaining pin.
5. Slide the caliper onto the disc, ensuring the pads pass either side, and fit the mounting bolts. Tighten the mounting bolts to **28 Nm**.
6. Tighten the pad retaining pin to **18 Nm**.

7. Fit the pad retaining pin plug to the caliper and tighten to **3 Nm**.

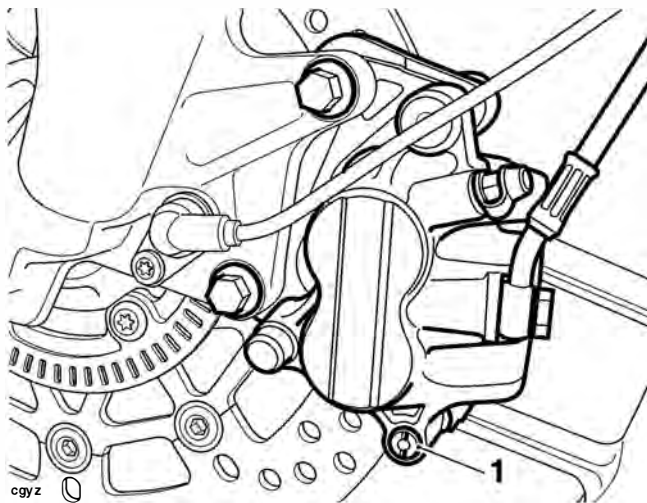

**1. Pad retaining pin plug**

8. Pump the brake lever to correctly position the caliper pistons.
9. Repeat the removal, inspection and installation process for the other caliper.

## Warning

Use only DOT 4 specification brake fluid as listed in the general information section of this manual. The use of brake fluids other than those DOT 4 fluids listed in the general information section may reduce the efficiency of the braking system leading to loss of motorcycle control and an accident.

Observe the brake fluid handling warnings given earlier in this section of the manual.

10. Check the front brake fluid level and top up as required with new DOT 4 fluid.
11. Check for correct brake operation. Rectify as necessary.

## Warning

It is dangerous to operate the motorcycle with defective brakes; you must have your authorised Triumph dealer take remedial action before you ride the motorcycle again. Failure to take remedial action may result in reduced braking efficiency leading to loss of motorcycle control and an accident.

## Front Brake Caliper

### Removal

#### Warning

Before starting work, ensure the motorcycle is stabilised and adequately supported. This will help prevent it from falling and causing injury to the operator or damage to the motorcycle.

#### Caution

To prevent paint damage, do not spill brake fluid onto any area of the bodywork. Spilled brake fluid will damage paintwork.

1. Remove the brake pads (see page 14-14).
2. Disconnect the brake hose at the caliper (two hoses on right hand caliper), and place the free end of the hose(s) in a suitable container to collect the brake fluid.

## Disassembly

### Warning

To prevent injury, never place fingers or hands inside the caliper opening when removing the pistons. Always wear eye, hand and face protection when using compressed air. Eye, face and skin damage will result from direct contact with compressed air.

1. Separate the caliper and mounting bracket.
2. Cover the caliper opening with a clean, heavy cloth and, using either compressed air or by reconnecting the master cylinder and pumping the brake lever, eject both pistons from the caliper at the same time.

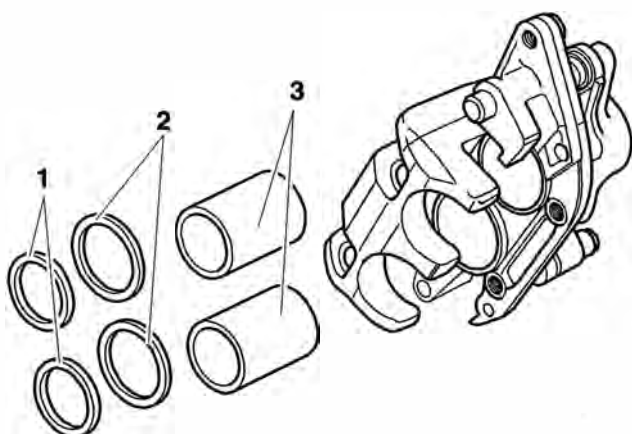

1. Dust seals
2. Piston seals
3. Pistons

### Warning

Ensure the seal grooves in the caliper bores are not damaged during the removal of the seals. Damage to the seal grooves may allow brake fluid to leak past the seals resulting in a dangerous riding condition leading to loss of motorcycle control and an accident.

3. Extract the dust seals and piston seals, taking care not to damage the caliper bores.
4. Check the pistons, caliper and mounting bracket for signs of damage, paying particular attention to the caliper bores and pistons. If damage is present, renew the worn component or the complete caliper assembly.
5. If all components are serviceable, obtain a piston seal kit and reassemble the caliper as follows:

### Warning

Always renew caliper seals after removal of the pistons. An effective hydraulic seal can only be made if new seals are fitted.

A dangerous riding condition leading to an accident could result if this warning is ignored.

### Warning

Before installation, all internal brake components should be cleaned and lubricated with clean new DOT 4 brake fluid.

Never use solvents, petrol (gasoline), engine oil, or any other petroleum distillate on internal brake components as this will cause deterioration of the hydraulic seals in the calipers and master cylinders.

A dangerous riding condition leading to loss of motorcycle control and an accident could result if this warning is ignored.

6. Ensure all components are clean, then fit the new seals to their grooves in the caliper bores.
7. Lubricate the fluid seals, caliper bore and the outside of the pistons with clean DOT 4 brake fluid.
8. Ease the pistons squarely back into the bores, taking care not to displace the seals.

### Warning

Never use mineral based grease (such as lithium or copper based grease) in any area where contact with the braking system hydraulic seals and dust seals is possible. Mineral based grease will damage the hydraulic seals and dust seals in the calipers and master cylinders. Damage caused by contact with mineral based grease may reduce braking efficiency resulting in an accident.

## Brakes

9. Lubricate the mounting bracket pins with a suitable silicone based brake grease then reassemble the bracket and caliper. Ensure the pin gaiters are correctly located on both the bracket and caliper.

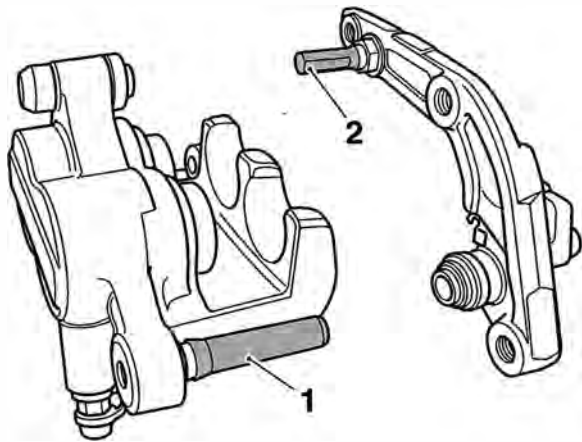

cfgg

1. Caliper sliding pin
2. Caliper bracket sliding pin

### Installation

1. Fit the brake pads (see page 14-37).
2. Connect the brake hose(s) to the caliper incorporating new sealing washers on each side of all hose connections.
3. Tighten the banjo bolt to **25 Nm**.

#### **Warning**

Use only DOT 4 specification brake fluid as listed in the general information section of this manual. The use of brake fluids other than those DOT 4 fluids listed in the general information section may reduce the efficiency of the braking system leading to loss of motorcycle control and an accident.

Observe the brake fluid handling warnings given earlier in this section of the manual.

4. Fill the master cylinder with new, DOT 4 brake fluid from a sealed container.
5. Bleed the front brake line (see page 14-12).
6. Check for correct brake operation.

#### **Warning**

It is dangerous to operate the motorcycle with defective brakes; you must have your authorised Triumph dealer take remedial action before you ride the motorcycle again. Failure to take remedial action may result in reduced braking efficiency leading to loss of motorcycle control and an accident.

## Front Discs

### Warning

Before starting work, ensure the motorcycle is stabilised and adequately supported. This will help prevent it from falling and causing injury to the operator or damage to the motorcycle.

### Wear

1. Replace any brake disc if worn beyond the service limit or that exceeds the disc run-out limit.

### Front Disc Thickness

Standard:	4.5 mm
Service Limit:	4.0 mm

### Disc Run-out

Service Limit:	0.15 mm
----------------	---------

Measure disc run-out using an accurate dial gauge mounted on a surface plate.

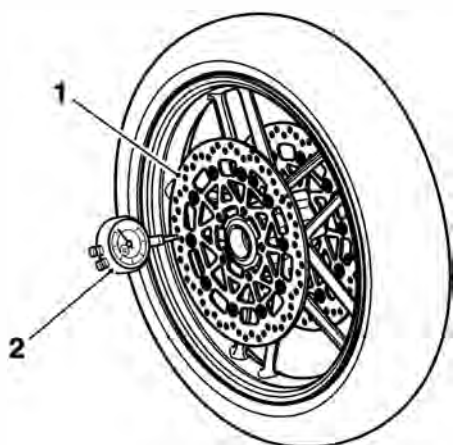

1. Disc
2. Dial gauge

## Removal

### Warning

Do not renew front brake discs individually. Discs must always be renewed in pairs even if one of a pair is serviceable.

A dangerous riding condition leading to an accident could result if this warning is ignored.

1. Remove the front wheel (see page 15-10).
2. Support the wheel on blocks as illustrated to avoid damage to the wheel centre.

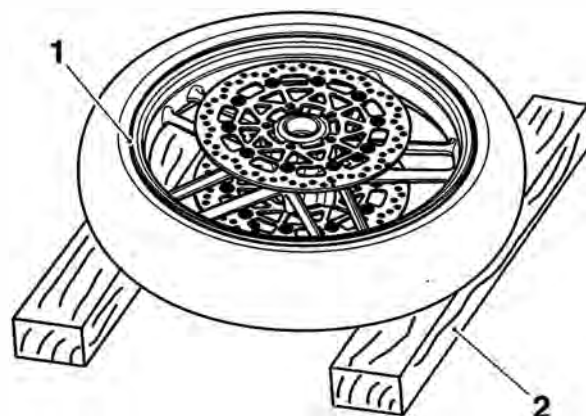

1. Wheel
2. Support blocks
3. Remove and discard the bolts.
4. Detach the disc. On ABS models, collect the ABS pulser ring from the left hand disc.
5. Repeat for the other disc.

# Brakes

## Installation

1. Locate the first disc to the wheel. On ABS models, refit the ABS pulser ring.
2. Fit new bolts and tighten to **22 Nm**.
3. Fit the other disc in the same way.
4. Refit the front wheel (see page 15-11).
5. Check for correct brake operation. Rectify as necessary.

### Warning

It is dangerous to operate the motorcycle with defective brakes; you must have your authorised Triumph dealer take remedial action before you ride the motorcycle again. Failure to take remedial action may result in reduced braking efficiency leading to loss of motorcycle control and an accident.

## Front Brake Master Cylinder

### Removal

### Warning

Before starting work, ensure the motorcycle is stabilised and adequately supported. This will help prevent it from falling and causing injury to the operator or damage to the motorcycle.

1. Remove the rider's seat (see page 16-13).
2. Disconnect the battery, negative (black) lead first.

### Caution

To prevent paint damage, do not spill brake fluid onto any area of the bodywork. Spilled brake fluid will damage paintwork.

3. To drain the fluid from the master cylinder, attach a tube to the right hand caliper bleed nipple, slacken the nipple and allow the fluid to drain into a suitable container. Operate the brake lever until all fluid has been expelled.
4. Note the setting of the brake lever adjuster to ensure it is returned to the same position when the overhaul operation is complete.
5. Remove the pivot locknut and bolt securing the brake lever to the master cylinder, and remove the lever.
6. Disconnect from the master cylinder the:
  - brake hose,
  - brake light switch connections.
7. Release the clamp screws from the handlebar to remove the master cylinder.

## Disassembly

1. Detach the rubber boot from the lever end of the cylinder.
2. Remove the circlip from beneath the boot.

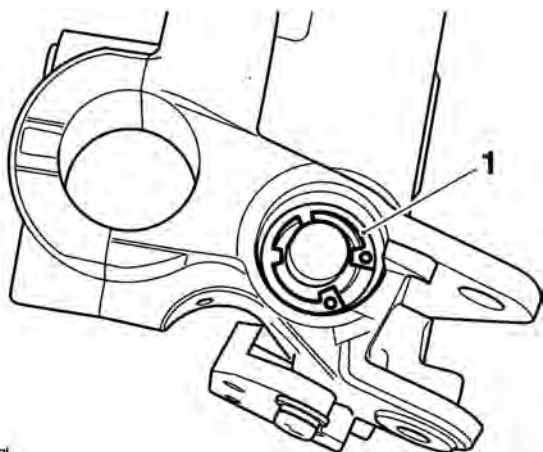

ceqi

### 1. Circlip

3. Remove the piston set from the master cylinder bore noting the relative position of the seals and piston components.

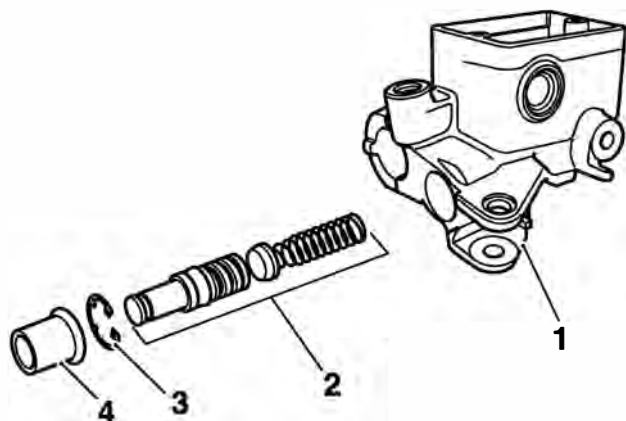

cequ

1. Master cylinder
2. Spring and piston assembly
3. Circlip
4. Rubber boot

## Inspection

1. Check the following for wear, damage, cracks or deterioration:
  - Cylinder bore
  - Rubber boot
  - Spring
  - Piston
  - Pivot Bolt
2. Always renew the piston and seal set if the cylinder is dismantled.
3. Check that the two ports in the master cylinder bore are not blocked.

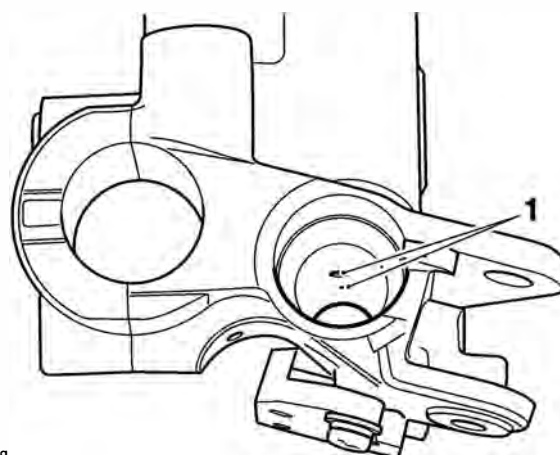

ceqj

### 1. Ports

# Brakes

## Assembly

### Warning

Never use mineral based grease (such as lithium or copper based grease) in any area where contact with the braking system hydraulic seals and dust seals is possible. Mineral based grease will damage the hydraulic seals and dust seals in the calipers and master cylinders. Damage caused by contact with mineral based grease may reduce braking efficiency resulting in an accident.

### Warning

Before installation, all internal brake components should be cleaned and lubricated with clean new DOT 4 brake fluid.

Never use solvents, petrol (gasoline), engine oil, or any other petroleum distillate on internal brake components as this will cause deterioration of the hydraulic seals in the calipers and master cylinders.

A dangerous riding condition leading to loss of motorcycle control and an accident could result if this warning is ignored.

1. Lubricate the piston and cylinder with new, clean brake fluid.

### Warning

Ensure that the piston and piston seal are fitted facing the same way as noted during removal. A dangerous riding condition leading to an accident could result from incorrect assembly of the master cylinder.

2. Fit the new piston set into the master cylinder and retain with a new circlip.
3. Refit the master cylinder boot.

## Installation

1. Locate the master cylinder to the handlebars and position the clamp with the 'UP' arrow pointing upwards.

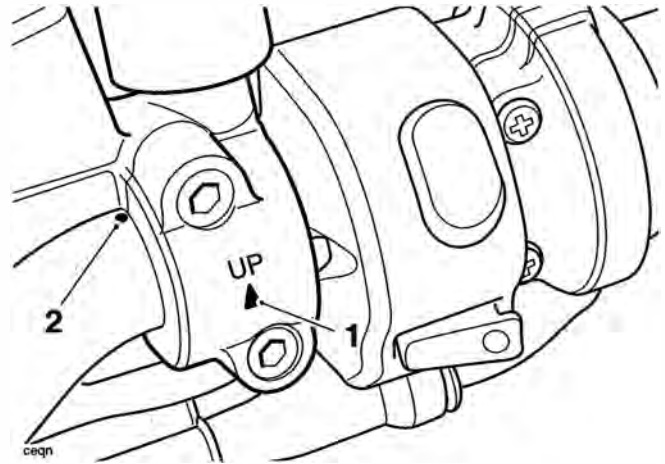

### 1. 'UP' Arrow

### 2. 'Dot' mark

2. Align the master cylinder/clamp split line with the 'dot' mark on the handlebar.
3. Tighten the clamp bolts, upper first and then the lower to **12 Nm**.
4. Connect the brake hose to the master cylinder incorporating new sealing washers. Tighten the banjo bolt to **25 Nm**.
5. Connect the brake light switch connections.
6. Position the brake lever ensuring that the pivot boss is correctly aligned to the push rod. Fit and tighten the pivot bolt to **1 Nm**, and the locknut to **6 Nm**.

### Warning

Use only DOT 4 specification brake fluid as listed in the general information section of this manual. The use of brake fluids other than those DOT 4 fluids listed in the general information section may reduce the efficiency of the braking system leading to loss of motorcycle control and an accident.

Observe the brake fluid handling warnings given earlier in this section of the manual.



- Fill and bleed the front brakes (see page 14-12).

## Warning

Always return the lever adjuster to the original setting noted during removal. Operating the motorcycle with lever settings which are unfamiliar may lead to loss of control or an accident.

- Reset the brake lever adjuster to the original setting.
- Examine the system for correct operation and fluid leaks. Rectify as necessary.
- Connect the battery, positive (red) lead first.
- Refit the rider's seat (see page 16-13).
- Check for correct brake operation. Rectify as necessary.

## Warning

It is dangerous to operate the motorcycle with defective brakes; you must have your authorised Triumph dealer take remedial action before you ride the motorcycle again. Failure to take remedial action may result in reduced braking efficiency leading to loss of motorcycle control and an accident.

## Bleeding the Rear Brakes, Renewing Brake Fluid

### Warning

Before starting work, ensure the motorcycle is stabilised and adequately supported. This will help prevent it from falling and causing injury to the operator or damage to the motorcycle.

- Remove the cap from the rear bleed nipple.
- Attach a transparent tube to the bleed nipple.

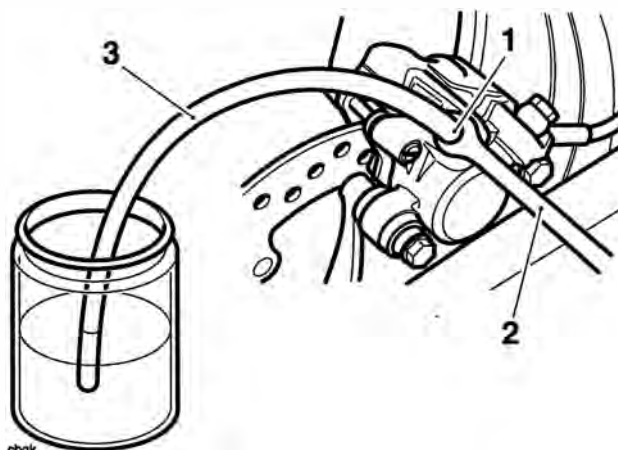

- Bleed nipple
- Spanner
- Bleed tube

- Place the other end of the tube in a suitable receptacle containing new brake fluid.

### Caution

To prevent paint damage, do not spill brake fluid onto any area of the bodywork. Spilled brake fluid will damage paintwork.

## Brakes

4. Unscrew and remove the rear brake reservoir cover taking care not to spill any fluid.

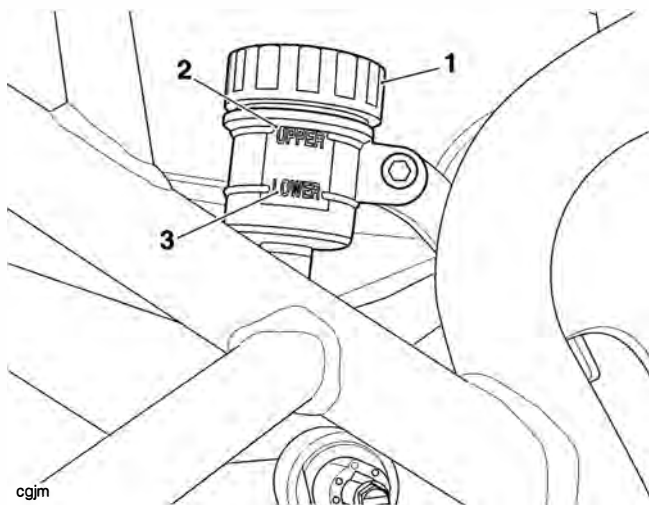

1. Rear reservoir
2. Rear reservoir upper level
3. Rear reservoir lower level

### Warning

Ensure absolute cleanliness when adding brake fluid to the brake fluid reservoir. Do not allow moisture or debris to enter the cylinder as this will adversely affect the fluid properties. Always use fluid from a sealed container and do not use fluid from a container which has been opened for any period of time. Always check for fluid leakage around hydraulic fittings and for damage to hoses.

A dangerous riding condition leading to an accident could result if this warning is ignored.

5. Check the condition of the sealing diaphragm. Replace the diaphragm as necessary.
6. Release the bleed nipple.

#### Note:

- **During bleeding, do not allow the fluid level to fall below the lower level mark in the reservoir. If the level is allowed to fall below this mark, air may enter the system and the sequence of bleeding must be repeated.**
7. Slowly depress the brake pedal and, holding the pedal fully down, close the bleed nipple.
  8. Repeat steps 6 and 7 until no more air appears in the bleed tube.
  9. Maintain the brake fluid level between the upper and lower reservoir levels whilst bleeding is being carried out.

10. When all air has been expelled from the system, hold down the brake pedal and close the bleed nipple. Tighten the nipple to **6 Nm**.
11. Fill the reservoir to the maximum level with new DOT 4 fluid.

### Warning

Use only DOT 4 specification brake fluid as listed in the general information section of this manual. The use of brake fluids other than those DOT 4 fluids listed in the general information section may reduce the efficiency of the braking system leading to loss of motorcycle control and an accident.

Observe the brake fluid handling warnings given earlier in this section of the manual.

12. Fit the reservoir cover and diaphragm. Check for correct diaphragm fitment before final tightening of the cover.
13. Remove the bleed tube from the nipple.
14. Replace the bleed nipple cap.
15. Check for correct brake operation. Rectify as necessary.

### Warning

It is dangerous to operate the motorcycle with defective brakes; you must have your authorised Triumph dealer take remedial action before you ride the motorcycle again. Failure to take remedial action may result in reduced braking efficiency leading to loss of motorcycle control and an accident.

## Rear Brake Pads

### Warning

Before starting work, ensure the motorcycle is stabilised and adequately supported. This will help prevent it from falling and causing injury to the operator or damage to the motorcycle.

1. Push the brake caliper inwards towards the wheel in order to displace the caliper piston.
2. Remove the plug protecting the pad retaining pin.

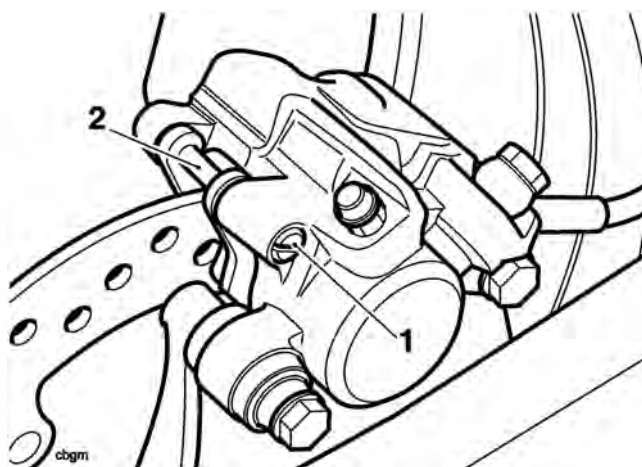

1. Plug
2. Pad retaining pin

#### Note:

- Before removing the brake pads, note the relationship of the pads to the caliper and ensure that, on assembly, they are fitted in the same way.

### Warning

Do not allow the caliper to hang on the brake hoses as this may damage the hoses and could lead to loss of motorcycle control and an accident.

3. Remove the brake caliper bolts and raise the caliper.

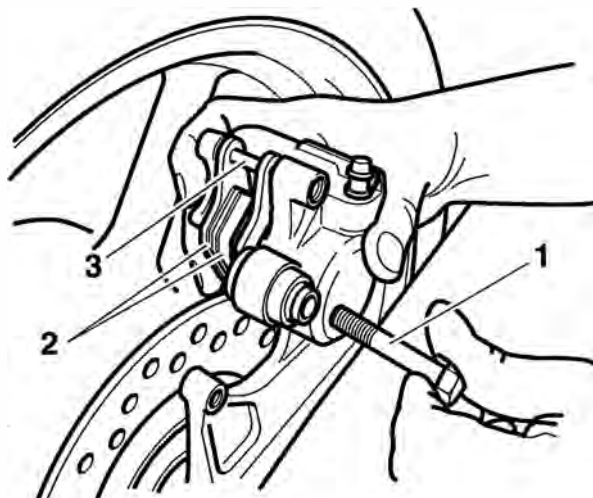

1. Brake caliper bolt
2. Brake pads
3. Pad retaining pin

4. Remove the pad retaining pin and remove the pads.
5. Remove the anti-rattle spring and inspect for damage.

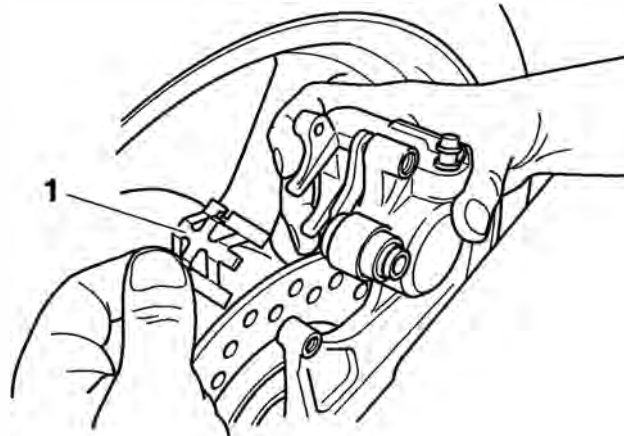

1. Anti-rattle spring

# Brakes

## Installation

### Warning

Never use mineral based grease (such as lithium or copper based grease) in any area where contact with the braking system hydraulic seals and dust seals is possible. Mineral based grease will damage the hydraulic seals and dust seals in the calipers and master cylinders. Damage caused by contact with mineral based grease may reduce braking efficiency resulting in an accident.

### Caution

To prevent paint damage, do not spill brake fluid onto any area of the bodywork. Spilled brake fluid will damage paintwork.

1. If fitting new pads, use hand pressure to compress the caliper piston fully into its bore.
2. Fit the anti rattle spring into the caliper.
3. Renew the brake pads as a pair or, if both pads are in a serviceable condition, clean the pad grooves before fitting them.
4. Fit the brake pads to the caliper in the positions noted during removal.

### Warning

Do not apply more than a minimum coating of grease to the pad retaining pins. Excess grease may contaminate the brake pads, hydraulic seals and discs causing reduced braking efficiency and an accident.

5. Lubricate the pad retaining pin using a minimum amount of proprietary high temperature 'Copaslip' type grease.
6. Install the pad retaining pin.

7. Lower the caliper over the brake disc ensuring that the pads remain in the correct positions.

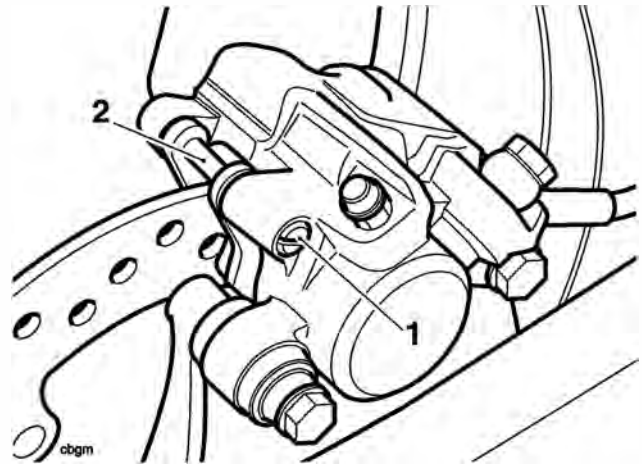

#### 1. Plug

#### 2. Pad retaining pin

8. Fit the caliper bolts and tighten to **22 Nm** (M8 bolt) and **27 Nm** (M12 bolt).
9. Tighten the pad retaining pin to **18 Nm**.
10. Fit the retaining plug and tighten to **3 Nm**.
11. Pump the brake pedal to correctly position the caliper pistons.
12. Check the brake fluid level in the rear reservoir and top-up as required with new DOT 4 fluid.

### Warning

Use only DOT 4 specification brake fluid as listed in the general information section of this manual. The use of brake fluids other than those DOT 4 fluids listed in the general information section may reduce the efficiency of the braking system leading to loss of motorcycle control and an accident.

Observe the brake fluid handling warnings given earlier in this section of the manual.

13. Check for correct brake operation. Rectify as necessary.

### Warning

It is dangerous to operate the motorcycle with defective brakes; you must have your authorised Triumph dealer take remedial action before you ride the motorcycle again. Failure to take remedial action may result in reduced braking efficiency leading to loss of motorcycle control and an accident.

## Rear Brake Caliper

### Removal

#### Warning

Before starting work, ensure the motorcycle is stabilised and adequately supported. This will help prevent it from falling and causing injury to the operator or damage to the motorcycle.

#### Caution

To prevent paint damage, do not spill brake fluid onto any area of the bodywork. Spilled brake fluid will damage paintwork.

1. Disconnect the rear brake hose at the caliper and place the free end of the hose in a suitable container to collect the brake fluid.
2. Remove the caliper mounting bolts.
3. Remove the brake caliper assembly.

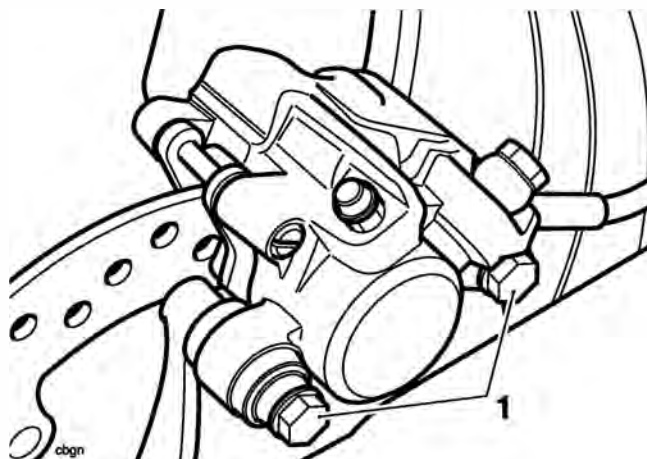

1. Caliper mounting bolts

### Disassembly

1. Remove the plug protecting the pad retaining pin.
2. Remove the pad retaining pin.
3. Remove the brake pads and anti-rattle spring.

#### Warning

To prevent injury, never place fingers or hands inside the caliper opening when removing the piston. Always wear eye, hand and face protection when using compressed air. Eye, face and skin damage will result from direct contact with compressed air.

4. Cover the caliper opening with a clean, heavy cloth and, using either compressed air or by reconnecting the master cylinder and pumping the brake lever, remove the piston.

### Inspection

1. Check the piston and caliper bore for corrosion, scoring and damage. Renew as necessary.

#### Warning

Always renew caliper seals and pistons after removal from the caliper. An effective hydraulic seal can only be made if new components are used.

A dangerous riding condition leading to an accident could result if this warning is ignored.

2. Inspect the brake pads for damage and wear beyond the service limit. Renew as necessary.

# Brakes

## Assembly

### Warning

Never use mineral based grease (such as lithium or copper based grease) in any area where contact with the braking system hydraulic seals and dust seals is possible. Mineral based grease will damage the hydraulic seals and dust seals in the calipers and master cylinders. Damage caused by contact with mineral based grease may reduce braking efficiency resulting in an accident.

### Warning

Ensure that the caliper bores do not become scratched during removal and assembly.  
A dangerous riding condition leading to an accident could result if this warning is ignored.

### Warning

Before installation, all internal brake components should be cleaned and lubricated with clean new DOT 4 brake fluid.  
Never use solvents, petrol (gasoline), engine oil, or any other petroleum distillate on internal brake components as this will cause deterioration of the hydraulic seals in the calipers and master cylinders.  
A dangerous riding condition leading to loss of motorcycle control and an accident could result if this warning is ignored.

1. Fit new fluid seals to the caliper. Apply brake fluid to the outside of the caliper piston and fluid seal.

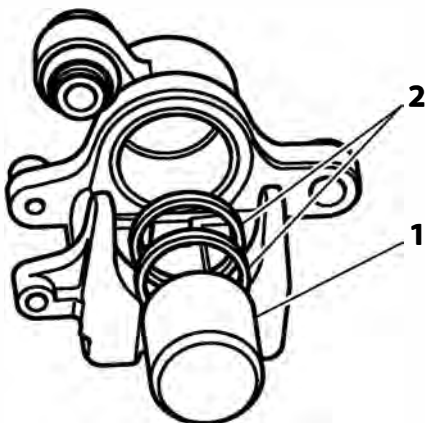

1. Piston
2. Seals

### Warning

Ensure that the piston does not tip during assembly as this could damage the caliper.  
A dangerous riding condition leading to an accident could result if this warning is ignored.

2. Carefully push the piston into the caliper by hand.
3. Install the anti-rattle spring into the caliper.
4. Position the brake pads in the caliper.

### Warning

Do not apply more than a minimum coating of grease to the pad retaining pins. Excess grease may contaminate the brake pads, hydraulic seals and discs causing reduced braking efficiency and an accident.

5. Lubricate the pad retaining pin using a minimum amount of proprietary high temperature 'Copaslip' type grease.
6. Fit and tighten the pad retaining pin to **18 Nm**.
7. Fit the retaining plug and tighten to **3 Nm**.
8. Apply a thin smear of silicone based brake grease to the outside of the sleeve and the sliding section of the bolt as shown below. Do not apply grease to the threads of the bolt.

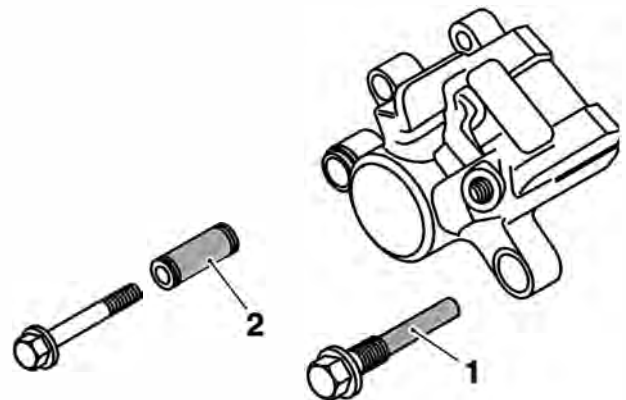

1. Bolt
2. Sleeve

## Installation

1. Position the caliper over the disc ensuring the pads are correctly aligned on both sides of the disc.
2. Fit the caliper retaining bolts and tighten to **22 Nm** (M8 bolt) and **27 Nm** (M12 bolt).
3. Connect the brake hose to the caliper incorporating new washers on each side of the banjo bolt.
4. Tighten the banjo bolt to **25 Nm**.
5. Fill the master cylinder with new, DOT 4 brake fluid from a sealed container.
6. Bleed the rear brake (see page 14-23).
7. Check for correct brake operation. Rectify as necessary.



### Warning

Use only DOT 4 specification brake fluid as listed in the general information section of this manual. The use of brake fluids other than those DOT 4 fluids listed in the general information section may reduce the efficiency of the braking system leading to loss of motorcycle control and an accident.

Observe the brake fluid handling warnings given earlier in this section of the manual.



### Warning

It is dangerous to operate the motorcycle with defective brakes; you must have your authorised Triumph dealer take remedial action before you ride the motorcycle again. Failure to take remedial action may result in reduced braking efficiency leading to loss of motorcycle control and an accident.

# Brakes

## Rear Brake Disc

### Wear

#### Warning

Before starting work, ensure the motorcycle is stabilised and adequately supported. This will help prevent it from falling and causing injury to the operator or damage to the motorcycle.

1. Replace any brake disc worn beyond the service limit or that exceeds the disc run-out limit.

### Rear Disc Thickness

Standard:	6.0 mm
Service Limit:	5.5 mm

### Disc Run-out

Service Limit:	0.50 mm
----------------	---------

Measure disc run-out using an accurate dial gauge mounted on a surface plate.

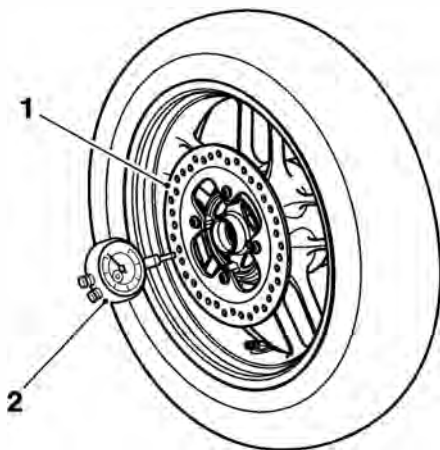

1. Disc
2. Dial gauge

#### Note:

- Details of rear brake disc removal and installation can be found in the wheel section.

## Rear Master Cylinder

### Removal

#### Warning

Before starting work, ensure the motorcycle is stabilised and adequately supported. This will help prevent it from falling and causing injury to the operator or damage to the motorcycle.

1. Remove the rider's seat (see page 16-13).
2. Disconnect the battery, negative (black) lead first.

#### Caution

To prevent paint damage, do not spill brake fluid onto any area of the bodywork. Spilled brake fluid will damage paintwork.

3. Remove the two fixings and remove the heel guard.
4. Drain the fluid from the master cylinder by bleeding the system at the rear caliper until all fluid has been expelled.
5. Remove the clip from the clevis pin at the lower end of the brake pushrod.
6. Remove the clevis pin.
7. Disconnect the rear brake light switch.
8. Remove the rear brake light and disconnect the rear brake hose from the master cylinder, noting its orientation.
9. Remove the screws securing the master cylinder to the frame and detach the master cylinder.

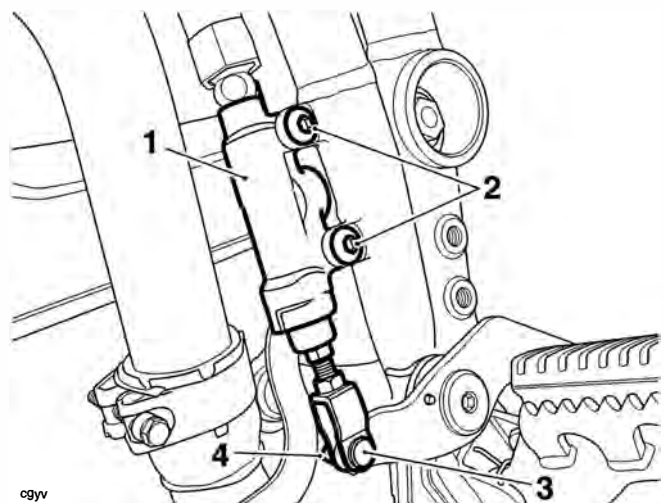

cg9v

1. Master cylinder
2. Master cylinder fixings
3. Clevis pin
4. Clip



10. Disconnect the reservoir hose and remove the master cylinder.

## Disassembly

1. Remove the boot from the cylinder and pushrod.
2. Remove the circlip retaining the pushrod to the cylinder.
3. Remove the pushrod and piston set from the master cylinder bore, noting the relative position of the seals and piston components.

## Inspection

1. Visually inspect the master cylinder bore for wear, scratches or corrosion. Replace as necessary.
2. Check the piston and cylinder bore for damage, wear or deterioration. Replace as necessary.
3. Always renew the piston and seal set if the cylinder is dismantled.
4. Examine the pushrod for bends and damage. Replace as necessary.

## Assembly

**Warning**

Never use mineral based grease (such as lithium or copper based grease) in any area where contact with the braking system hydraulic seals and dust seals is possible. Mineral based grease will damage the hydraulic seals and dust seals in the calipers and master cylinders. Damage caused by contact with mineral based grease may reduce braking efficiency resulting in an accident.

**Warning**

Before installation, all internal brake components should be cleaned and lubricated with clean new DOT 4 brake fluid.

Never use solvents, petrol (gasoline), engine oil, or any other petroleum distillate on internal brake components as this will cause deterioration of the hydraulic seals in the calipers and master cylinders.

A dangerous riding condition leading to loss of motorcycle control and an accident could result if this warning is ignored.

1. Clean the master cylinder bore, piston and seals, with new brake fluid.
2. Ensure all ports are clear of obstruction.

**Warning**

Ensure that the piston and piston seal are fitted facing the same way as noted during removal. A dangerous riding condition leading to an accident could result from incorrect assembly of the master cylinder.

3. Install the spring and piston set together.
4. Apply a small amount of brake grease to the pushrod.
5. Install the pushrod in the master cylinder and retain with a new circlip.
6. Refit the boot.

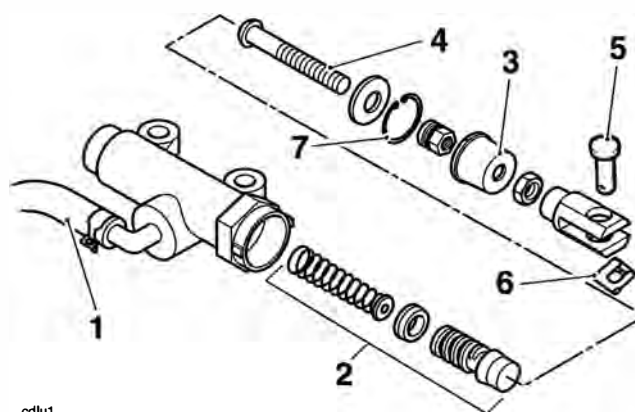

odlu1

1. Reservoir hose
2. Piston set
3. Dust boot
4. Push rod
5. Clevis pin
6. Clip
7. Circlip

## Brakes

- If the pushrod has been disassembled, adjust the length of the pushrod as shown below:

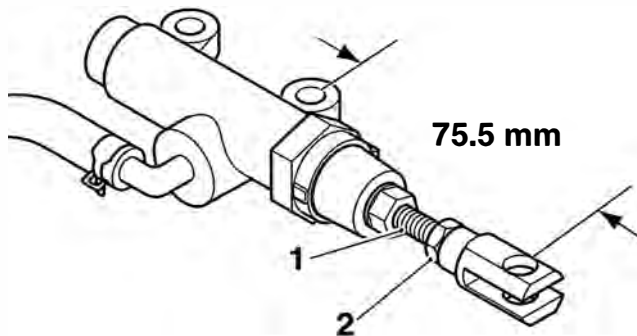

- Pushrod**
- Locknut**

- Set the pushrod free length to 75.5 mm.
- Tighten the locknut to **18 Nm**.

### Installation

- Fit the reservoir hose to the master cylinder.
- Secure the master cylinder to the frame. Tighten the securing screws to **16 Nm**.
- Connect the push rod to the brake pedal using a new clevis pin and clip.

- Incorporating new washers, fit the brake hose to the master cylinder. Ensuring correct orientation of the brake hose, tighten the brake light switch to **15 Nm**.

### Warning

Use only DOT 4 specification brake fluid as listed in the general information section of this manual. The use of brake fluids other than those DOT 4 fluids listed in the general information section may reduce the efficiency of the braking system leading to loss of motorcycle control and an accident.

Observe the brake fluid handling warnings given earlier in this section of the manual.

- Fill and bleed the rear brake system (see page 14-23).
- Refit the heel guard, tightening the fixings to **12 Nm**.
- Reconnect the battery, positive (red) lead first.
- Refit the rider's seat (see page 16-13).
- Check for correct brake operation. Rectify as necessary.

### Warning

It is dangerous to operate the motorcycle with defective brakes; you must have your authorised Triumph dealer take remedial action before you ride the motorcycle again. Failure to take remedial action may result in reduced braking efficiency leading to loss of motorcycle control and an accident.

## Bleeding the Front Brakes - Motorcycles with ABS

### Warning

Before starting work, ensure the motorcycle is stabilised and adequately supported. This will help prevent it from falling and causing injury to the operator or damage to the motorcycle.

1. Complete the brake bleed procedure as for models without ABS brakes (see page 14-12).
2. Connect the Triumph diagnostic tool (See page 14-48).
3. Follow the on screen menu to ABS Diagnostics. From the menu, select 'BLEED SYSTEM' (see the Triumph Diagnostic Tool User Guide).

#### Note:

- **On pressing the Start button, the diagnostic software will send a command to the ABS ECM to open the 2<sup>nd</sup> circuit solenoid.**
  - **The front brake lever travel will increase as ABS modulator solenoids are opened and will then decrease as the solenoids are automatically closed.**
  - **Pressure must be applied to the front brake lever before operating the bleed sequence on the diagnostic tool. An assistant will be required to open the bleed nipple while pressure is applied to the brake lever.**
4. Apply pressure to the front brake lever, press the Start button to activate the bleed sequence on the diagnostic tool, and with assistance, release one of the bleed nipples.
  5. Get an assistant to slowly pull the brake lever to the handlebar.
  6. With the lever held fully against the handlebar, close the bleed nipple. Once the bleed nipple is closed, release the brake lever.
  7. Repeat steps 5 and 6 until no more air appears in the bleed tube, maintaining the brake fluid level between the upper and lower reservoir levels whilst bleeding is being carried out.
  8. The bleed sequence will run for a maximum of 90 seconds. Press the Stop button to end the bleed sequence at any time. Once the bleed sequence has completed the diagnostic tool will display a message 'ABS system bleed complete'.

### Caution

The ABS modulator must be allowed to cool between bleeding operations. Always allow the ABS modulator to cool for 5 minutes before starting the bleed procedure again. Failure to follow this instruction may result in damage to the ABS modulator.

9. Repeat the above procedure as necessary until all air is expelled from the system.
10. When all air has been expelled from the system, apply pressure to the brake lever and close the bleed nipple. Tighten the nipple to **6 Nm**.
11. Repeat the brake bleed procedure as for models without ABS brakes (see page 14-12).

## Front ABS Wheel Sensor

### Removal

 **Warning**

Before starting work, ensure the motorcycle is stabilised and adequately supported. This will help prevent it from falling and causing injury to the operator or damage to the motorcycle.

1. Disconnect the battery negative (black) lead first.
2. Remove the rider's seat (see page 16-13).
3. Remove the fuel tank (see page 10-91).

#### Note:

- **Note the routing of the harness and its retaining clips for installation.**
4. Disconnect the wheel speed sensor multiplug, identified as the white connector, located below the ignition switch.
  5. Release the wheel speed sensor harness from the brake hose clips.
  6. Release the bolt and remove the sensor. Collect the shim from between the sensor and fork leg and discard the bolt.

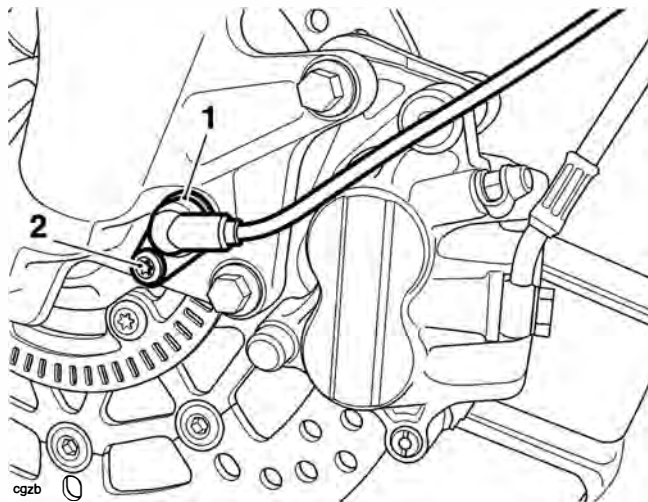

**1. Front ABS wheel speed sensor**  
**2. Bolt**

### Installation

#### Note:

- **Check the condition of the shim before use. Do not use a shim which is bent or damaged.**
1. Position the wheel speed sensor to the fork leg with its shim between the sensor and fork leg. Temporarily fit the original bolt and tighten to **9 Nm**.
  2. The air gap between the wheel speed sensor and the pulser ring must be between 0.1 mm and 1.5 mm. Check and adjust the wheel speed sensor air gap as described on page 14-38.
  3. Once the wheel speed sensor air gap measurement is correct, install a new bolt (if not already replaced during air gap adjustment) and tighten to **9 Nm**.
  4. Route the harness and secure to the brake hose clips as noted for removal.
  5. Connect the wheel speed sensor multiplug.
  6. Refit the fuel tank (see page 10-91).
  7. Connect the battery, positive (red) lead first.
  8. Refit the rider's seat (see page 16-13).
  9. Check that the brakes operate correctly.

## Front ABS Pulsar Ring

### Removal

#### Warning

Before starting work, ensure the motorcycle is stabilised and adequately supported. This will help prevent it from falling and causing injury to the operator or damage to the motorcycle

1. Remove the front wheel (see page 15-10).

#### Warning

Damage to the wheel centre could cause misalignment of the wheel when refitted. A dangerous riding condition leading to an accident could result if this warning is ignored.

2. Support the wheel on blocks as illustrated below.

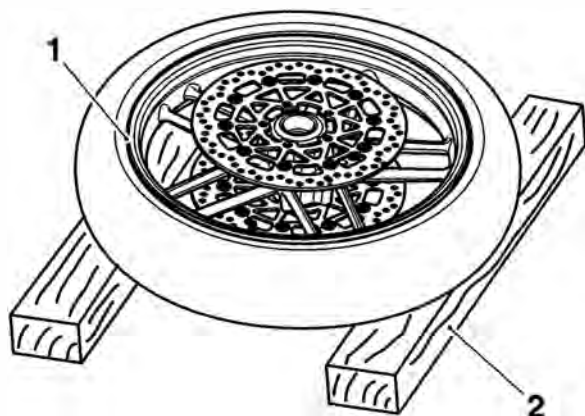

1. Wheel
2. Support block

3. Remove and discard the five disc bolts and remove the pulser ring.

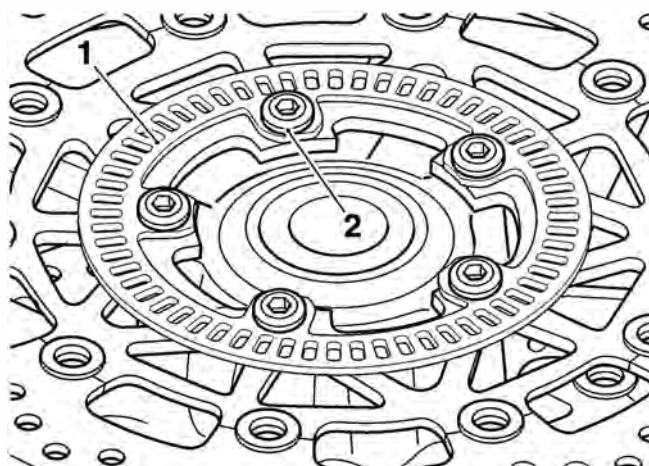

1. Pulser ring
2. Disc bolt

### Inspection

1. Check the pulser ring for damage, missing or cracked teeth or distortion. Renew the pulser ring as necessary.

### Installation

1. Locate the pulser ring on to the wheel, fit new disc bolts and tighten to **22 Nm**.
2. Refit the front wheel (see page 15-11).
3. Check, and if necessary, adjust the air gap between the front wheel speed sensor and the pulser ring (see page 14-38).
4. Check that the brakes operate correctly.

### Bleeding the Rear Brake Fluid - Motorcycles with ABS



#### Warning

Before starting work, ensure the motorcycle is stabilised and adequately supported. This will help prevent it from falling and causing injury to the operator or damage to the motorcycle.

1. Complete the brake bleed procedure as for models without ABS brakes (see page 14-23).
2. Connect the Triumph diagnostic tool (See page 14-48).
3. Follow the on screen menu to ABS Diagnostics. From the menu, select BLEED SYSTEM (see the Triumph Diagnostic Tool User Guide).

#### Note:

- **On pressing the Start button, the diagnostic software will send a command to the ABS ECM to open the 2nd circuit solenoid.**
  - **The rear brake pedal travel will increase as ABS modulator solenoids are opened and will then decrease as the solenoids are automatically closed.**
  - **Pressure must be applied to the rear brake pedal before operating the bleed sequence on the diagnostic tool. An assistant will be required to open the bleed nipple while pressure is applied to the brake pedal.**
4. Apply pressure to the rear brake pedal, press the Start button to activate the bleed sequence on the diagnostic tool, and with assistance, release the bleed nipple.
  5. Slowly depress the brake pedal and, holding the pedal fully down, close the bleed nipple. Repeat until no more air appears in the bleed tube, maintaining the brake fluid level between the upper and lower reservoir levels whilst bleeding is being carried out.

6. The bleed sequence will run for a maximum of 90 seconds. Press the Stop button to end the bleed sequence at any time. Once the bleed sequence has completed the diagnostic tool will display a message 'ABS system bleed complete'.



#### Caution

The ABS modulator must be allowed to cool between bleeding operations. Always allow the ABS modulator to cool for 5 minutes before starting the bleed procedure again. Failure to follow this instruction may result in damage to the ABS modulator.

7. Repeat the above procedure as necessary until all air is expelled from the system.
8. When all air has been expelled from the system, hold down the brake pedal and close the bleed nipple. Tighten the nipple to **6 Nm**.
9. Repeat the brake bleed procedure as for models without ABS brakes (see page 14-23).

## Rear ABS Wheel Speed Sensor

### Removal

**Warning**

Before starting work, ensure the motorcycle is stabilised and adequately supported. This will help prevent it from falling and causing injury to the operator or damage to the motorcycle.

1. Remove the rider's seat (see page 16-13).
2. Remove the battery (see page 17-8)
3. Disconnect the wheel speed sensor multiplug, located under the battery.
  - **Note the routing of the ABS sensor harness for installation.**
4. Detach the ABS sensor harness from its clips on the rear brake hose.
5. Release the fixing securing the wheel speed sensor to the rear brake caliper carrier and remove the sensor. Collect the shim and discard the fixing.

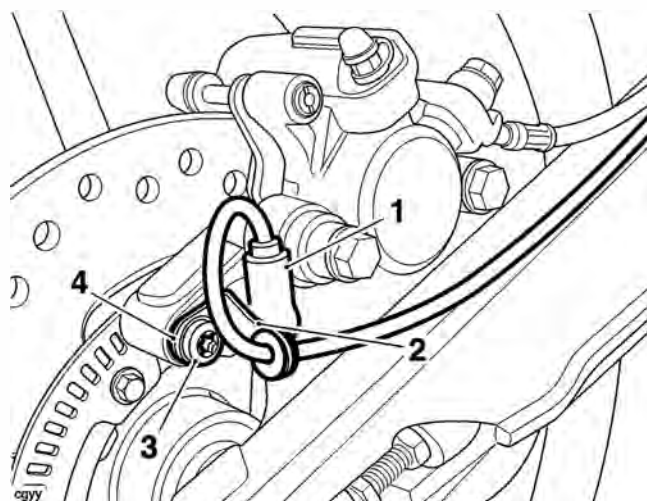

1. ABS sensor
2. ABS harness bracket
3. Fixing
4. Shim(s)

### Installation

#### Note:

- **Check the condition of the shim before use. Do not use a shim which is bent or damaged.**
1. Position the shim to the fixing such that it will be installed between the wheel speed sensor and the brake caliper carrier.
  2. Fit the wheel speed sensor, harness bracket and shim to the brake caliper carrier as noted during removal. Temporarily fit the original bolt and tighten to **9 Nm**.
  3. The air gap between the wheel speed sensor and the pulser ring must be between 0.1 mm and 1.5 mm. Check and adjust the wheel speed sensor air gap as described on page 14-38.
  4. Once the wheel speed sensor air gap measurement is correct, install a new bolt (if not already replaced during air gap adjustment) and tighten to **9 Nm**.
  5. Attach the ABS sensor harness to its clips on the brake hose.
  6. Connect the wheel speed sensor multiplug.
  7. Refit the battery (see page 17-8).
  8. Refit the rider's seat (see page 16-13).
  9. Check that the brakes operate correctly.

# Brakes

## Rear ABS Pulsar Ring

### Removal

#### Warning

Before starting work, ensure the motorcycle is stabilised and adequately supported. This will help prevent it from falling and causing injury to the operator or damage to the motorcycle.

1. Remove the rear wheel (see page 15-12).
2. Remove and discard the four screws and remove the pulser ring.

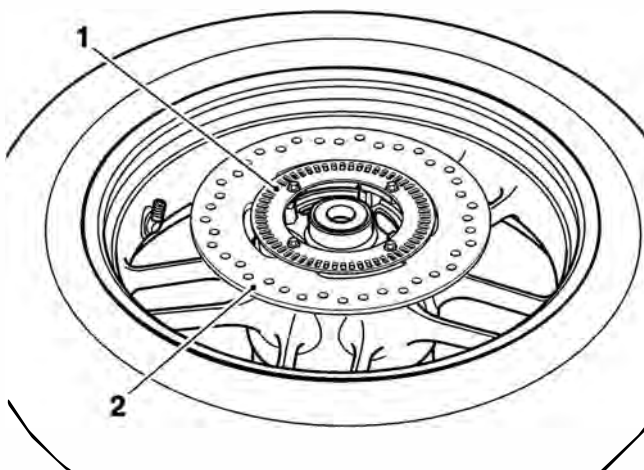

1. Axle shaft
2. Pulser ring
3. Brake disc

### Inspection

1. Check the pulser ring for damaged, missing or cracked teeth or distortion. Renew the pulser ring as necessary.

### Installation

1. Locate the pulser ring to the rear brake disc.
2. Install new screws and tighten to **5 Nm**.
3. Refit the rear wheel (see page 15-12).
4. Check, and if necessary, adjust the air gap between the rear wheel speed sensor and the pulser ring (see page 14-38).
5. Check that the brakes operate correctly.

## Air Gap Measurement - Front and Rear Wheel Speed Sensors

1. Using feeler gauges, measure the air gap between the wheel speed sensor and the pulser ring.

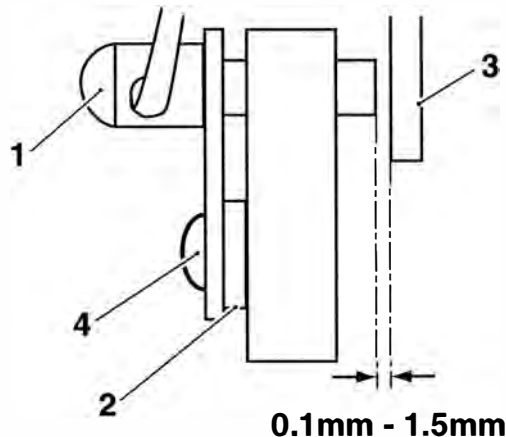

cdhj\_1

1. ABS sensor
2. Shim
3. Pulser ring
4. Fixing

2. Rotate the wheel and repeat the measurement in several places to ensure the pulser ring is not distorted or bent. Renew a damaged pulser ring.
3. Adjust the air gap using the correct shim(s) to achieve an air gap between 0.1 mm to 1.5 mm.

### Note:

- Shims are available in the following sizes, **0.8 mm and 1.6 mm**.
  - **Do not install more than two shims. If the required air gap cannot be achieved using two shims, investigate and rectify the cause before proceeding.**
4. If necessary, remove the wheel speed sensor, fit the correct thickness shim(s) and refit the wheel speed sensor.
  5. If removed, install a new fixing and tighten to **9 Nm**.
  6. Repeat the air gap measurement. Re-adjust as necessary.



## ABS Hydraulic Modulator/ECM

### Removal

#### Warning

Before starting work, ensure the motorcycle is stabilised and adequately supported. This will help prevent it from falling and causing injury to the operator or damage to the motorcycle.

1. Remove the rider's seat (see page 16-13).
2. Disconnect the battery, negative (black) lead first.
3. Remove the fuel tank (see page 10-91).
4. Remove the airbox (see page 10-98).
5. Remove the upper ABS modulator fixing.
6. Remove the four fixings and remove the front seat bridge.

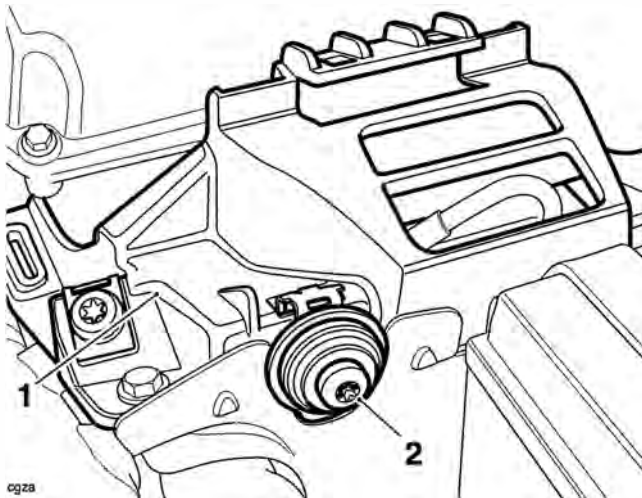

- cgza
1. Front seat bridge
  2. ABS modulator upper fixing

#### Caution

To prevent body damage, do not spill brake fluid onto any area of the bodywork or wheels.

7. Drain the brake fluid from the front and rear master cylinders (for front brake master cylinder see page 14-12, and for rear brake master cylinder see page 14-23).

8. Remove the three fixings and detach the rear brake hose P-clips from the rear swinging arm and ABS modulator bracket (located under the rear mudguard).

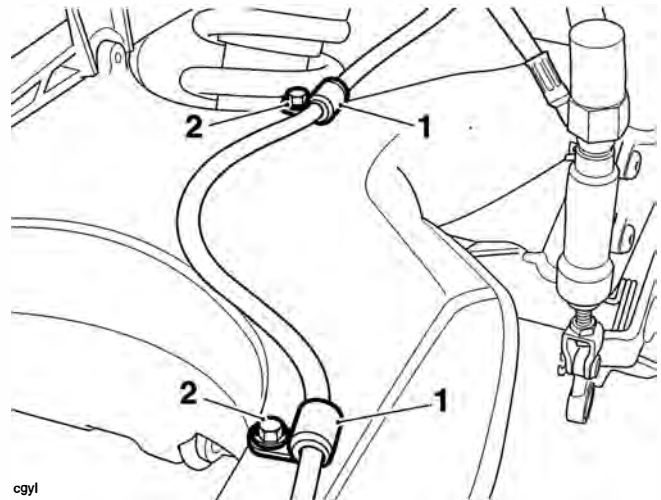
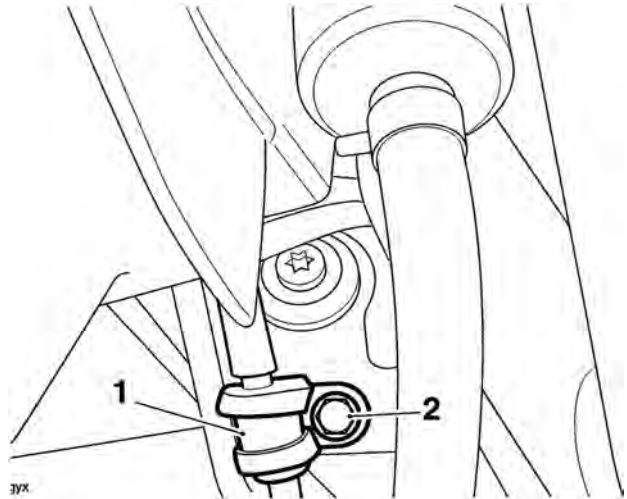

- cgyl
1. P-clips
  2. Fixings

9. Detach the ABS wheel speed sensor cable from the rear brake hose.
10. Disconnect the ABS modulator multiplug (See page 14-53).

# Brakes

11. Remove the fixing and detach the battery negative cable form the upper crankcase.

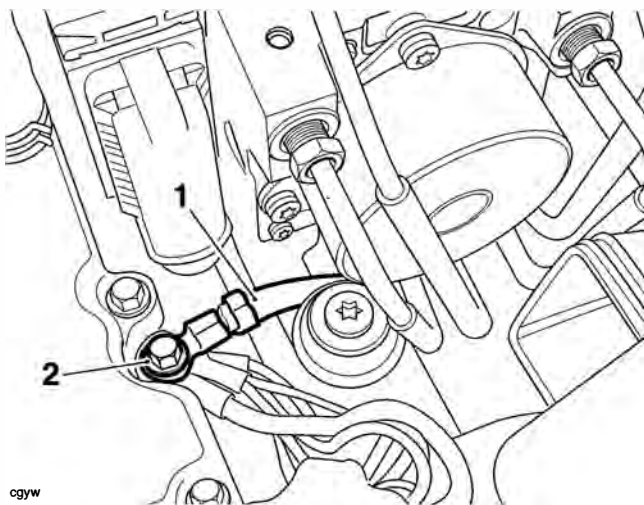

cgylw

- 1. Battery negative cable**  
**2. Fixing**

12. Remove the rear brake light switch and disconnect the rear master cylinder hose at the master cylinder. Discard the sealing washers.

## Warning

Before the disassembly of any brake lines in the ABS hydraulic circuit, always mark their position so that they can be returned to the same position when assembled. If the brake lines are incorrectly assembled the performance of the ABS system will be seriously compromised, leading to loss of motorcycle control and an accident.

13. Detach the three front brake hard line clips from the frame.

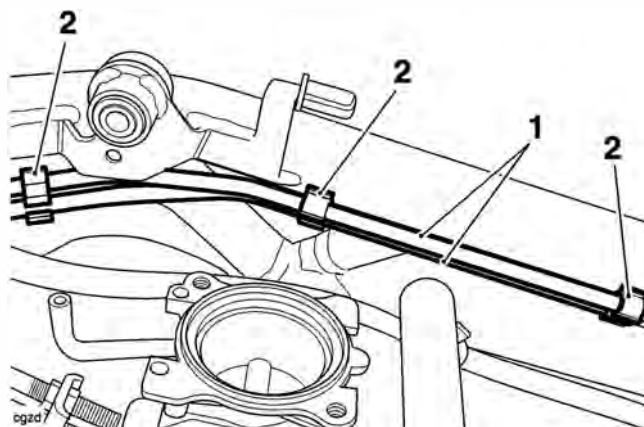

- 1. Front brake hard lines**  
**2. Clips**

14. Remove the left hand lower ABS modulator fixing, located under the front seat bridge.

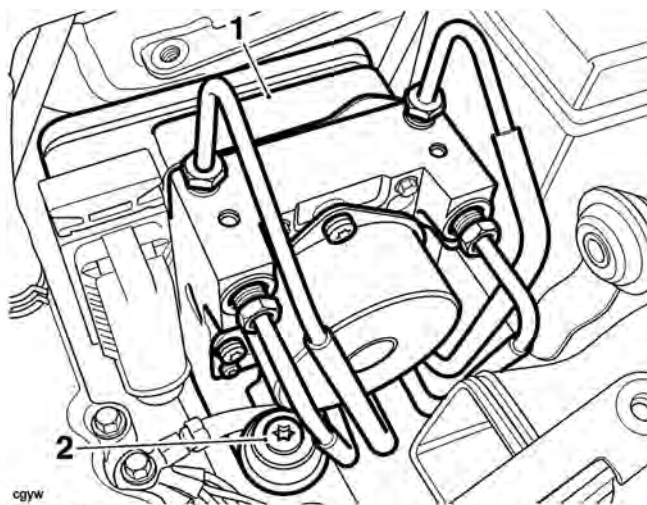

cgylw

- 1. ABS modulator**  
**2. Left hand lower fixing**

15. Remove the right hand lower ABS modulator fixing, located under the rear mudguard.

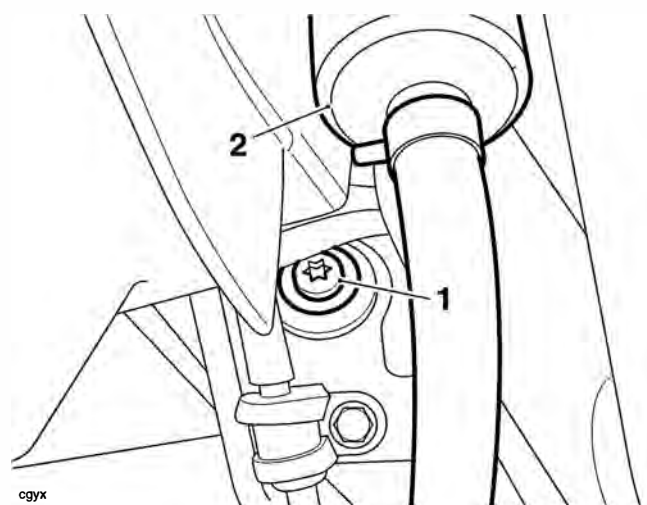

cgylx

- 1. Right hand lower ABS modulator fixing**  
**2. Rear brake fluid reservoir**

## Warning

Do not allow the brake hard lines to become bent or kinked during ABS modulator removal. If the brake lines are bent or kinked the performance of the ABS system will be seriously compromised, leading to loss of motorcycle control and an accident.

### Note:

- The battery negative cable is routed between the ABS modulator and the bracket, and is removed at the same time as the modulator assembly.

## **Caution**

To prevent body damage, do not spill brake fluid onto any area of the bodywork or wheels.

16. Carefully raise the modulator, with the brake lines still attached, upwards from the motorcycle until access to the underside of the modulator can be gained.  
With the aid of an assistant, support the modulator in this position.
17. Detach the four brake lines from the clips on the underside of the modulator bracket.
18. Noting their orientation, disconnect the four brake hard line unions and, taking care not to bend the brake lines, detach the lines from the ABS modulator.
19. Remove the ABS modulator and bracket from the motorcycle.



cgze

- 1. ABS modulator**
- 2. Front brake master cylinder hard line**
- 3. Front brake caliper hard line**
- 4. Rear brake master cylinder hard line**
- 5. Rear brake caliper hard line**
- 6. Battery negative lead**

20. Noting its routing, remove the battery negative cable from the modulator assembly.

21. Remove the three screws and remove the bracket from the ABS modulator.

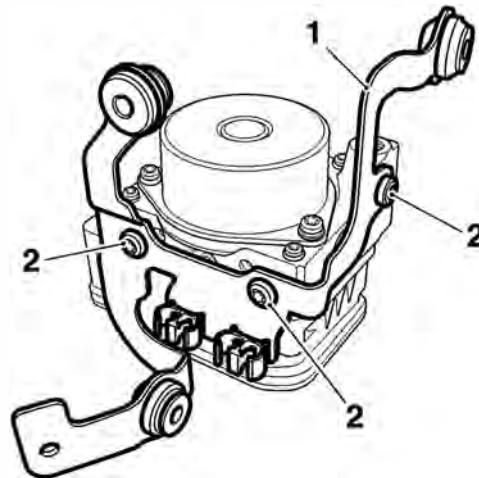

cgzf

- 1. ABS modulator bracket**
- 2. Screws**

# Brakes

## Installation

1. Align the ABS modulator to its bracket, fit new screws and tighten to **9 Nm**.

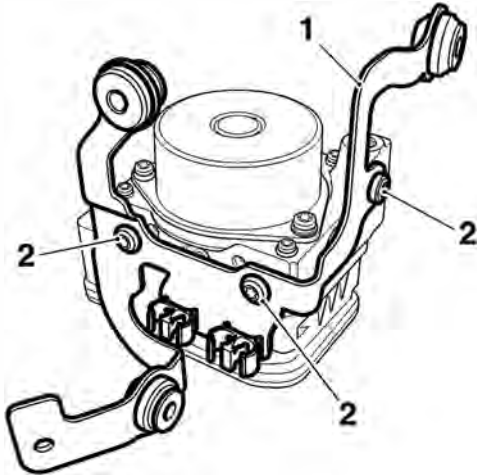

cgzf

- 1. ABS modulator**
- 2. Screws**

2. Re-route the battery negative lead between the modulator and bracket as noted during removal.
3. Reposition the modulator to the two front brake lines and screw the brake line unions in to the modulator. Do not tighten the brake line unions at this stage.
4. Refit the brake lines in to the clip on the underside of the modulator.
5. Reposition the two rear brake lines to the modulator and screw the brake line unions in to the modulator. Do not tighten the brake line unions at this stage.
6. Refit the brake lines in to the clip on the underside of the modulator.



cgze

- 1. ABS modulator**
- 2. Front brake master cylinder hard line**
- 3. Front brake caliper hard line**
- 4. Rear brake master cylinder hard line**
- 5. Rear brake caliper hard line**
- 6. Battery negative lead**

7. Carefully manoeuvre the ABS modulator and bracket assembly to its fitted position on the frame. Ensure the brake hard lines and hoses are routed as noted during disassembly.
8. Fit the two lower ABS modulator fixings and washers. Tighten to **9 Nm**.
9. Tighten the four unions to **25 Nm**, taking care to ensure the brake lines do not twist during tightening.
10. Refit the battery negative lead to the upper crankcase, tightening the fixing to **9 Nm**.
11. Refit the three front brake hard line clips to the frame.

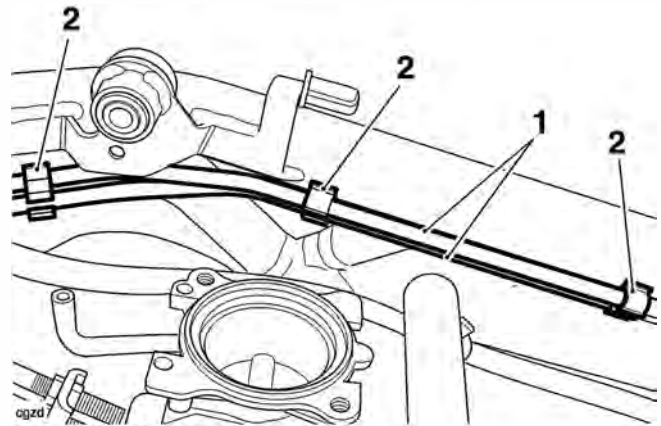

- 1. Front brake hard lines**
- 2. Clips**

12. Incorporating new washers, fit the rear master cylinder hose to the master cylinder. Ensuring correct orientation of the brake hose, tighten the rear brake light switch to **15 Nm**.
13. Connect the brake hose to the caliper incorporating new washers on each side of the banjo bolt.
14. Tighten the banjo bolt to **25 Nm**.
15. Refit the three rear brake hose P-clips, tightening the fixings to **6 Nm**.
16. Clip the rear ABS sensor cable to the rear brake hose.
17. Reconnect the ABS modulator multiplug, and ensure the locking device is fully engaged (see page 14-53).
18. Refit the front seat bridge, tightening the fixings to **5 Nm**.
19. Refit the upper ABS modulator fixing and tighten to **9 Nm**.
20. Refit the airbox (see page 10-101).
21. Refit the fuel tank (see page 10-92).
22. Reconnect the battery, positive (red) lead first.



## Warning

Use only DOT 4 specification brake fluid as listed in the general information section of this manual. The use of brake fluids other than those DOT 4 fluids listed in the general information section may reduce the efficiency of the braking system leading to an accident.

Observe the brake fluid handling warnings given earlier in this section of the manual.

23. Bleed the front brakes (see page 14-33).
24. Bleed the rear brakes (see page 14-36).
25. Refit the rider's seat (see page 16-13).



## Warning

It is dangerous to operate the motorcycle with defective brakes; you must have your authorised Triumph Dealer take remedial action. Failure to take remedial action may reduce braking efficiency leading to loss of motorcycle control and an accident.

26. Check that the brakes operate correctly.

## ABS

### System Description

The ABS versions of the Tiger 800 and Tiger 800XC are fitted with an electronic anti-lock brake system (ABS) which is designed to prevent the wheels from locking or skidding by reducing braking effort to the front or rear brake caliper when wheel-lock is detected.

The system consists of a hydraulic modulator and ECM assembly mounted to a bracket to the rear of the airbox, a front wheel speed sensor mounted to the front fork, and a rear wheel speed sensor mounted to the rear brake caliper carrier.

Both front and rear wheels have a pulser ring mounted on to the wheel, the front being mounted to the wheel hub, the rear being mounted to the rear brake disc.

The front and rear master cylinders are connected via lines to the modulator and from the modulator the pipes connect to the brake calipers. The calipers and master cylinders are identical to the non-ABS equipped motorcycle.

The front and rear brake circuits operate as separate systems. The front and rear brakes are not connected in any way inside the modulator.

The modulator ECM continuously calculates the front and rear wheel speeds, and from these inputs the ECM calculates the estimated motorcycle speed, wheel deceleration/acceleration, the wheel speed difference and the wheel slip (skid) rate. This is calculated by comparing the calculated wheel speeds with the calculated vehicle speed, so that if one wheel speed deviates significantly from the other two readings, this wheel is determined to be skidding.

Under braking, if the modulator detects that either wheel is about to slip, due to the brake force exceeding the available traction between the tyre and road surface (the wheel will begin to slip or 'skid'), the ECM very rapidly releases and re-applies the brake pressure to prevent the wheel from skidding.

This is felt through the brake pedal or lever as a rapid 'pulsing'.

If the rider reduces braking effort, or traction increases (so that traction exceeds braking force, the wheel will rotate once more) the wheel will no longer lock up. The ABS system will detect this and stop controlling brake pressure, and return to its monitoring state.

The system has a self diagnostic function built-in which monitors the fail safe relay, solenoid valves, motor relay, wheel speed sensors, power supply and ground, as well as internal ECM functions. In the event of a malfunction being detected, the ECM will illuminate the ABS warning light, and store a diagnostic trouble code in the system memory. This stored data can then be recovered using a special service tool which is mandatory for all Triumph dealers. In this way, precise diagnosis of a fault can be made and the fault quickly rectified.

Under normal operation, the ABS warning light will flash on and off after ignition on until the vehicle speed exceeds 6 mph (10 km/h). If a trouble code is stored the ABS warning light will stay illuminated and the ABS will not function, however the brakes will operate normally. If the ABS warning light does not extinguish, or illuminates whilst the motorcycle is being ridden, refer to the ABS system diagnostics (see page 14-48).

**Component Location**

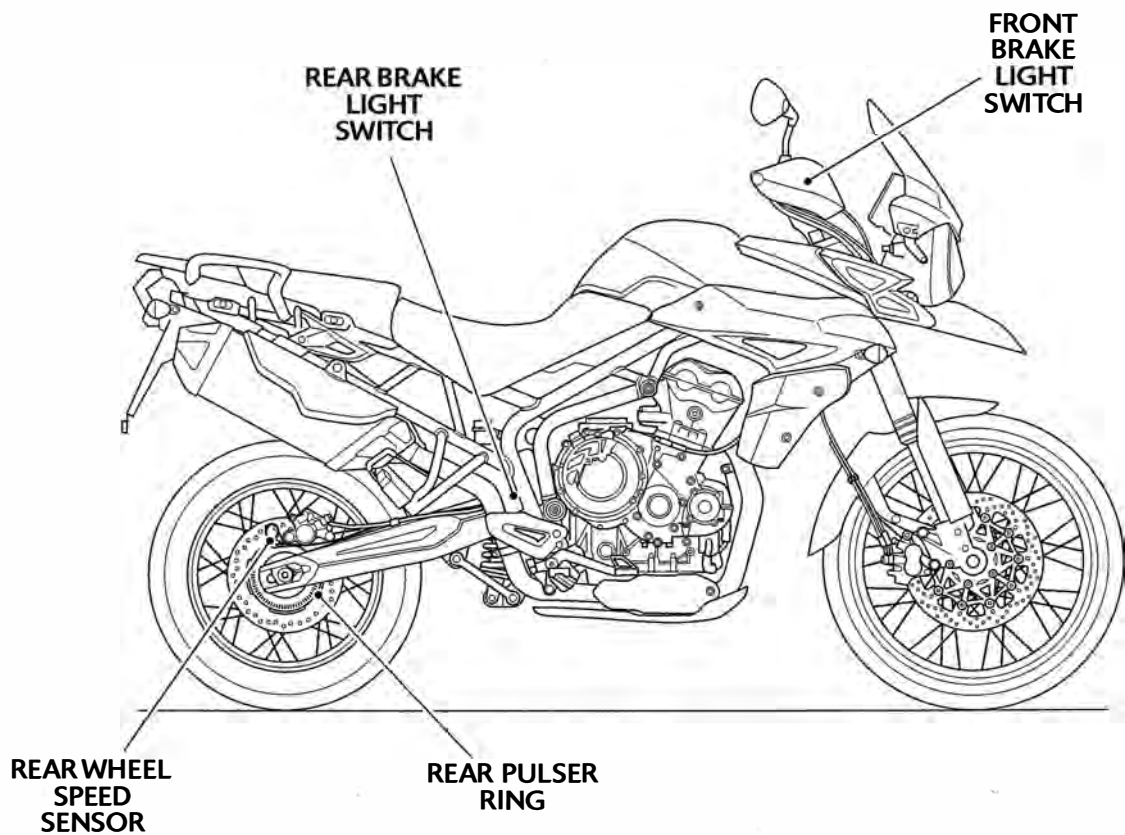
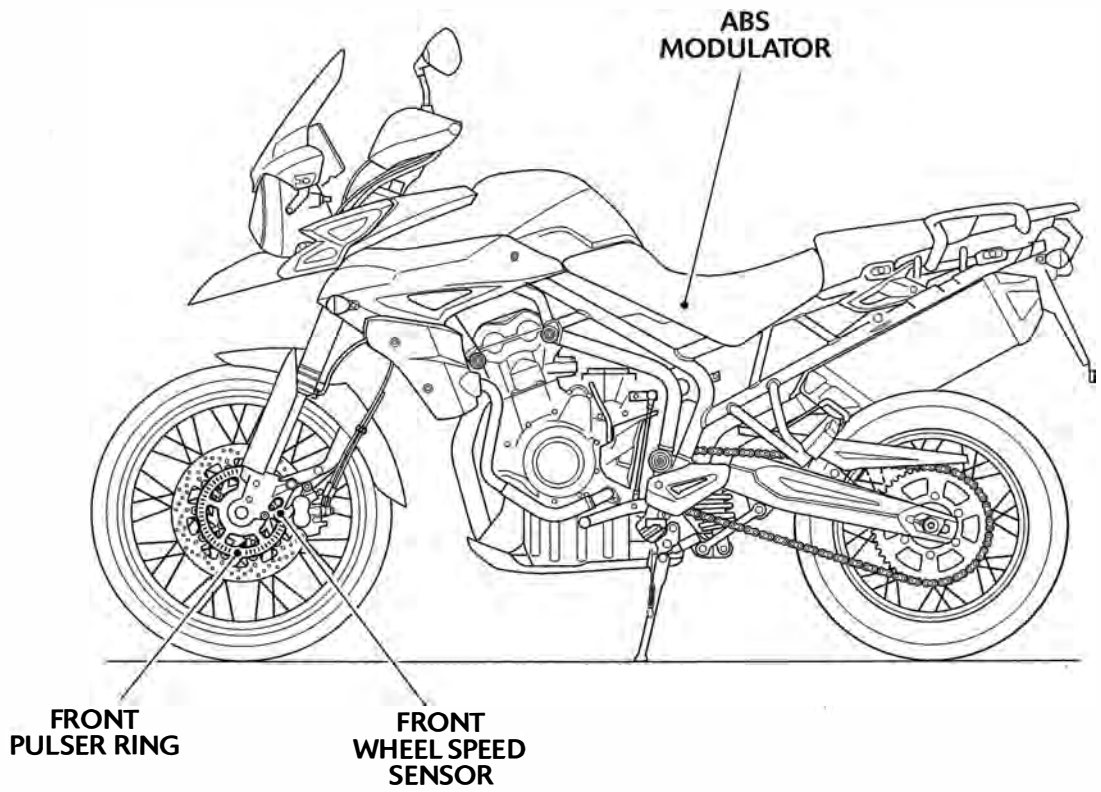

# Brakes

## ABS System Circuit Diagram

## ABS ECM Connector Pin Numbering

### Key to Wiring Diagram

Key	Item Description
1	ABS Modulator
2	Rear Fuse Box (Fuses 1 and 2)
3	Headlamp Relay
4	Front Brake Light Switch
5	Brake Light
6	Rear Brake Light Switch
7	Front Wheel Speed Sensor
8	Rear Wheel Speed Sensor
9	Instruments
10	Diagnostic Connector
11	Engine Control Module

### Key to wiring colour codes

Code	Wiring Colour
B	Black
U	Blue
N	Brown
G	Green
S	Slate/Grey
O	Orange
K	Pink
R	Red
P	Purple
W	White
Y	Yellow
LG	Light Green
LU	Light Blue

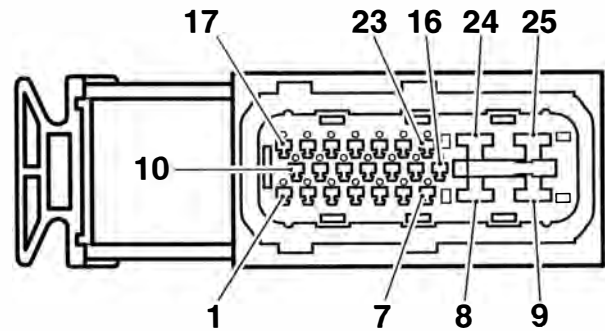

cdhg

The above illustration shows the pin numbering system used in the ABS circuit diagram.

As viewed on the mating face with the ABS ECM (as per the illustration), pins are numbered from left to right with number one in the bottom left hand corner.



ABS System Circuit Diagram

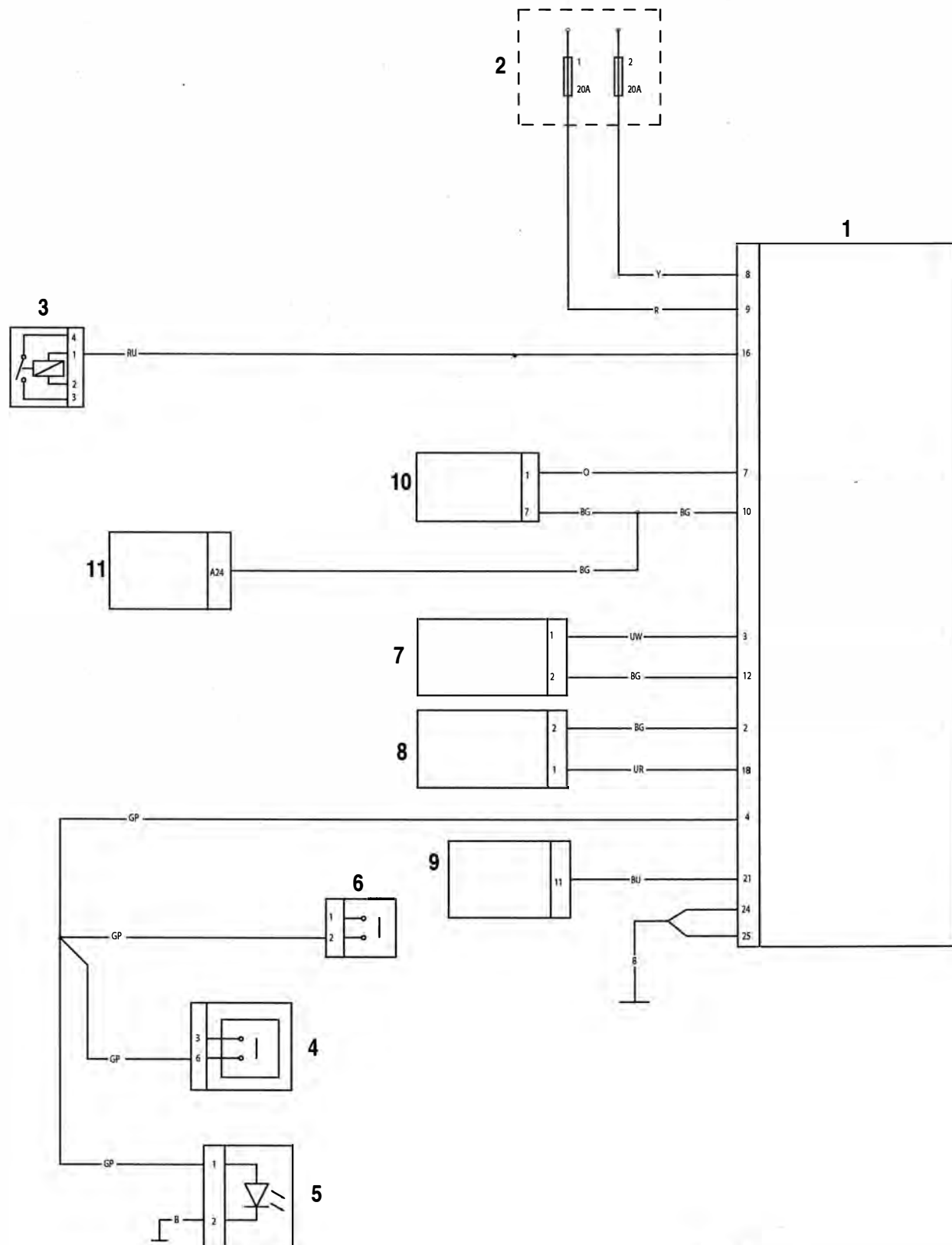

## System Diagnostics

The ABS system has an on-board diagnostics feature which allows service technicians to retrieve stored data from the ECM using Triumph diagnostic software. **Full details of the Triumph diagnostic software operation are given in the Triumph Diagnostic Tool User Guide.**

The software is connected, via an interface cable, to the motorcycle using a dedicated diagnostic plug situated under the seat. By using a dedicated plug, no electrical connectors associated with the system are disturbed, reducing potential connector damage.

The software allows the user to retrieve data associated with the system sensors and actuators, test various component functions, read build data and make minor adjustments to the set-up of the system. The data and tests available are described on the following pages.

## Diagnostic Tool Connection

1. To connect the Triumph diagnostic interface to the motorcycle, remove the pillion seat (see page 16-13) and release the diagnostic connector from its locating tang.
2. Plug the diagnostic interface directly in to the diagnostic connector.

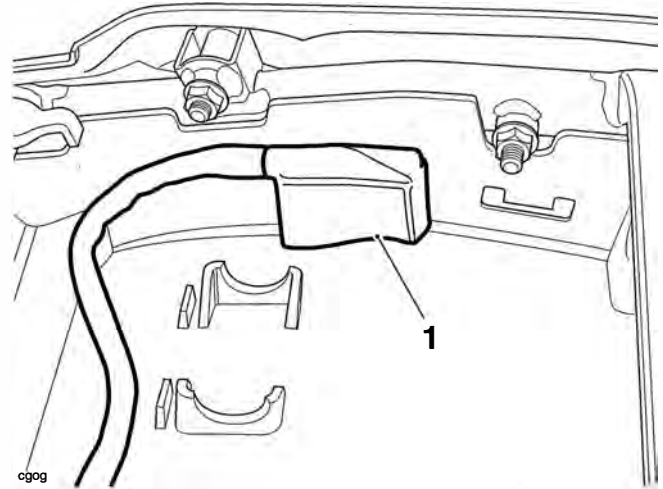

1. Diagnostic connector



### Diagnostic Interface

3. When the diagnostic session is completed, disconnect the Triumph diagnostic interface.
4. Refit the diagnostic connector to its locating tang and refit the pillion seat (see page 16-13).

## Triumph Diagnostic Tool

Described on the following pages is the range of information which can be retrieved from the ECM's memory and the adjustments which can be performed using the Triumph diagnostic software.

The tables indicate which tests are performed by the on-board system and what information can be retrieved by the Triumph diagnostic software.

### Note:

- **Full details of how to operate the software can be found in the Triumph Diagnostic Tool User Guide, which can be downloaded by authorised Triumph dealers from [www.triumphonline.net](http://www.triumphonline.net).**

### Build Data

The **Build Data** screen will display the following information:

Function Examined
ECM type
ECM ID number
Software version number

### Current Data

The **Current Data** screen will display the following information:

Function Examined	Result Reported (Scale)
Front wheel speed	Kph
Rear wheel speed	Kph
Brake switch status	On/Off
ABS warning light status	On/Off

### Bleed System

Using the Triumph diagnostic tool, it is possible to bleed the ABS modulator of trapped air. This is necessary when the hydraulic brake system has been dismantled, or the ABS modulator renewed.

Full details of this procedure are provided on page 14-33 for front brakes or page 14-36 for rear brakes.

# Brakes

---

## Diagnostic Trouble Codes

Diagnostic trouble codes (DTCs) are logged in the ABS ECM memory when there is a confirmed fault in the system.

The codes are reported to the Triumph diagnostic tool as a four digit code.

DTCs can be removed at any time using the Triumph diagnostic tool.

The system will log the diagnostic trouble codes listed below:

Diagnostic (DTC)	Trouble Code	Fault Description
C1611		Front Wheel Sensor Open Circuit/Short Circuit
C1612		Front Wheel Sensor Abnormal Input/Losing Contact
C1613		Rear Wheel Sensor Open Circuit/Short Circuit
C1614		Rear Wheel Sensor Abnormal Input/Losing Contact
C1621		Front Wheel Pulser Gear Missing Teeth
C1623		Rear Wheel Pulser Gear Missing Teeth
C1631		Front Wheel Input Solenoid Open/Short Circuit
C1632		Front Wheel Output Solenoid Open/Short Circuit
C1633		Rear Wheel Input Solenoid Open/Short Circuit
C1634		Rear Wheel Output Solenoid Open/Short Circuit
C1641		Front Wheel Actuator (Hydraulic Control) Wheel Lock
C1643		Rear Wheel Actuator (Hydraulic Control) Wheel Lock
C1651		Motor - Lock
C1652		Motor - Stuck OFF
C1653		Motor - Stuck ON
C1654		Solenoid Relay - Stuck OFF/ON
C1661		Power Source Voltage Drop
C1662		Power Source Voltage Rise
C1671		Different Tyre Diameter
C1681		Abnormal ECU

## Diagnostic Trouble Codes

Dependant on the DTC stored, the ABS ECM will act in one of two ways:

a) Inhibit ABS operation immediately, irrespective of the ABS operating mode;

or

b) Allow the ABS operation to complete before inhibiting the ABS.

Once the ABS ECM has inhibited ABS function, the ECM will act in one of three ways:

a) Allow the ABS to resume operation if the fault clears;

or

b) Allow ABS operation after an ignition cycle if the fault clears;

or

c) Inhibit the ABS function until the fault is rectified and the DTC erased.

The ABS system will act on the DTC stored according to the tables on the following pages:

Fault Description	ABS warning light illuminated when fault is logged	ABS operation is inhibited when fault is logged	ABS continues to operate when fault is logged (Only when ABS is Active. When ABS is no longer active, operation is inhibited)	ABS will resume operation if fault clears
Front Wheel Sensor Open Circuit/Short Circuit	Yes	Yes		No
Front Wheel Sensor Abnormal Input/Losing Contact	Yes	Yes	Yes	Yes, if after ignition cycle, no fault is detected. DTC remains stored
Rear Wheel Sensor Open Circuit/Short Circuit	Yes	Yes		No
Rear Wheel Sensor Abnormal Input/Losing Contact	Yes	Yes	Yes	Yes, if after ignition cycle, no fault is detected. DTC remains stored
Front Wheel Pulser Gear Missing Teeth	Yes		Yes	Yes, if after ignition cycle, no fault is detected for 1 second and speed exceeds 30 km/h. DTC remains stored
Rear Wheel Pulser Gear Missing Teeth	Yes		Yes	Yes, if after ignition cycle, no fault is detected for 1 second and speed exceeds 30 km/h. DTC remains stored
Front Wheel Input Solenoid Open/Short Circuit	Yes	Yes		No
Front Wheel Output Solenoid Open/Short Circuit	Yes		Yes	No

## Brakes

<b>Fault Description</b>	<b>ABS warning light illuminated when fault is logged</b>	<b>ABS operation is inhibited when fault is logged</b>	<b>ABS continues to operate when fault is logged (Only when ABS is Active. When ABS is no longer active, operation is inhibited)</b>	<b>ABS will resume operation if fault clears</b>
Rear Wheel Input Solenoid Open/Short Circuit	Yes	Yes		No
Rear Wheel Output Solenoid Open/Short Circuit	Yes		Yes	No
Front Wheel Actuator (Hydraulic Control) Wheel Lock	Yes		Yes	Yes, if after ignition cycle, no fault is detected. DTC remains stored
Rear Wheel Actuator (Hydraulic Control) Wheel Lock	Yes		Yes	Yes, if after ignition cycle, no fault is detected. DTC remains stored
Motor - Lock	Yes		Yes	No
Motor - Stuck OFF	Yes		Yes	No
Motor - Stuck ON	Yes		Yes	No
Solenoid Relay - Stuck OFF/ ON	Yes	Yes		No
Power Source Voltage Drop	Yes, Light will extinguish if fault clears	Yes		Yes, if voltage rises above a preset threshold for more than 10 seconds
Power Source Voltage Rise	Yes, Light will extinguish if fault clears	Yes		Yes, if voltage drops below a preset threshold for more than 10 seconds
Different Tyre Diameter	Yes	Yes		No
Abnormal ECU	Yes	Yes		No

## Electrical Connectors

Before beginning any diagnosis, the following connector related information should be noted:

### Note:

- **A major cause of hidden electrical faults can be traced to faulty electrical connectors.**

For example:

- Dirty/corroded terminals.
- Damp terminals.
- Broken or bent cable pins within multi-plugs.

For example, the ABS electronic control modulator (ABS ECM) relies on the supply of accurate information to enable it to monitor and control the brake system. One dirty terminal will cause an excessive voltage drop resulting in an incorrect signal to the ECM.

If, when carrying out fault diagnosis, a fault appears to clear by simply disconnecting and reconnecting an electrical plug, examine each disconnected plug for the following.

### Before Disconnection:

- If testing with a voltmeter, the voltage across a connector should be virtually battery volts (unless a resistor is fitted in the circuit). If there is a noticeable change, suspect faulty/dirty connections.

### When Disconnecting a Connector:

- Check for a security device that must be released before the connector can be separated. E.G. barb, hook and eye etc.

### When Inspecting a Connector:

- Check that the individual pins have not been bent.
- Check for dampness/dirt/corrosion.
- Check cables for security.
- Check cable pin joints for damage.

### When Connecting a Connector.

- Ensure there is no dirt around the connector/seal.
- Push together squarely to ensure terminals are not bent or incorrectly located.
- Push the two halves together positively.

## Disconnection of ABS ECM Connector

### ⚠ Caution

When disconnecting a connector, never pull directly on the wires as this may result in cable and connector damage.

### ⚠ Caution

Never disconnect the ABS ECM when the ignition switch is in the ON position as this may cause multiple fault codes to be logged in the ECM memory.

Always disconnect an ECM after disconnecting the battery negative (black) lead first.

1. Lift up the locking device and gently pull back on the connector to release it from the ECM.

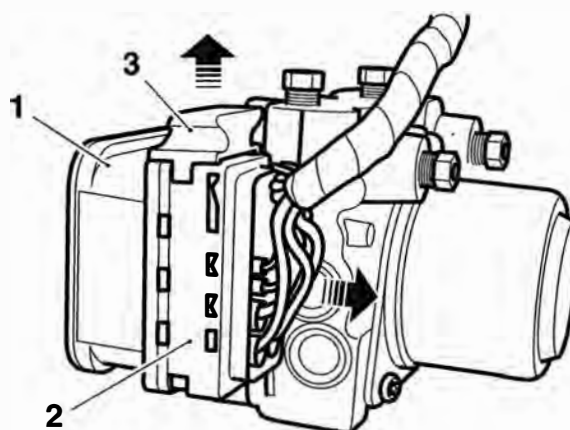

cfyr\_6

1. ABS modulator
2. Connector
3. Locking device

### Note:

- **The ABS ECM is an integral part of the ABS modulator. Under no circumstances should the ECM be removed from the ABS modulator. If a new ECM is required, repair is by replacement of the ABS modulator and ECM as an assembly only.**

# Brakes

## Reconnection of ABS ECM Connector

### **Caution**

Damage to the connector pins may result if an attempt to fit the connectors incorrectly is made.

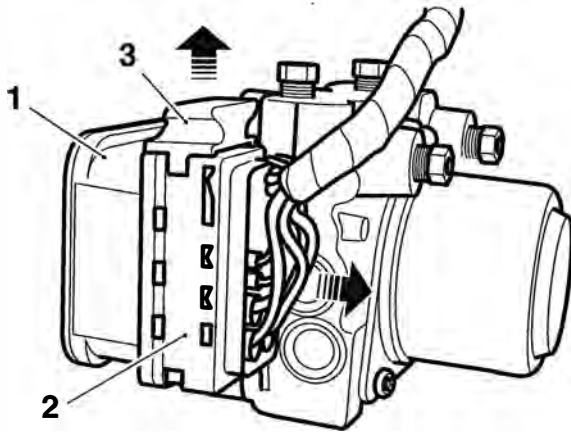

cfyr\_6

- 1. **ABS modulator**
- 2. **Connector**
- 3. **Locking device**

1. Fit the connector into its socket and, whilst holding the connector in place, push down gently on the locking device until it locks.

## Further Diagnosis

The tables that follow will, if used correctly, help to pinpoint a fault in the system once a diagnostic trouble code has been stored.

### Pinpoint Tests

#### Before starting pinpoint tests

1. Delete the stored DTCs.
2. Switch the ignition OFF and ON.

### **Warning**

If the ABS is not functioning, the brake system will continue to function as a non-ABS braking system. Do not continue to ride for longer than is necessary with the indicator light illuminated. Ride with extreme caution when performing diagnostic troubleshooting on a non-functioning ABS system. In this situation braking too hard will cause the wheels to lock resulting in loss of motorcycle control and an accident.

3. Ride the motorcycle at a road speed in excess of 30 Km/h. If the DTC is repeated proceed to the relevant pinpoint test.
4. If the DTC is not repeated this indicates the DTC may have been stored due to external influences such as bad road surfaces or electrical interference.

#### After completion of the pinpoint tests

1. Delete the stored DTCs.
2. Switch the ignition OFF and ON.
3. Ride the motorcycle at a road speed in excess of 30 Km/h. If the DTC is repeated proceed to the relevant pinpoint test.
4. If a DTC is stored there is a further fault. Read the stored DTC and refer to the relevant pinpoint test.



## ABS Warning Light ON (No DTCs Stored)

Fault Code	Possible cause	Action
ABS Warning Light ON (No DTCs Stored)	ABS Ignition supply fuse/circuit fault ABS Warning light circuit fault	Ensure ABS ECM connector is secure. Disconnect ABS ECM connector and proceed to pinpoint test 1:-

### Pinpoint Tests

Test	Result	Action
1 Check cable and terminal integrity: - ABS ECM connector pin 16 and Ground pin 24	OK	Proceed to test 2
	Faulty	Rectify fault, proceed to test 5
2 Check cable continuity of the ABS ignition supply circuit: With Ignition 'ON', check voltage between - ABS ECM connector pin 16 and Ground	Same as 'across battery' voltage	Proceed to test 3
	Less than 'across battery' voltage	Locate and rectify wiring fault, proceed to test 5
3 Check cable continuity of the ABS warning light circuit: Check voltage between: - ABS ECM connector pin 21 and Ground	Voltage greater than 1.5 V	Proceed to test 4
	Voltage less than 1.5 V	Locate and rectify fault, proceed to test 5
4 Check cable continuity of the ABS warning light circuit: - Short ABS ECM connector pin 21 and Ground pin 24 together:  Turn Ignition 'ON'	ABS warning light 'OFF'	Proceed to test 5
	ABS warning light 'ON'	Locate and rectify fault, proceed to test 5
5 Reconnect ABS ECM harness, clear fault code and test ABS to verify fault cleared	OK	Action complete - quit test
	Fault still present	Contact Triumph service

### Circuit Diagram

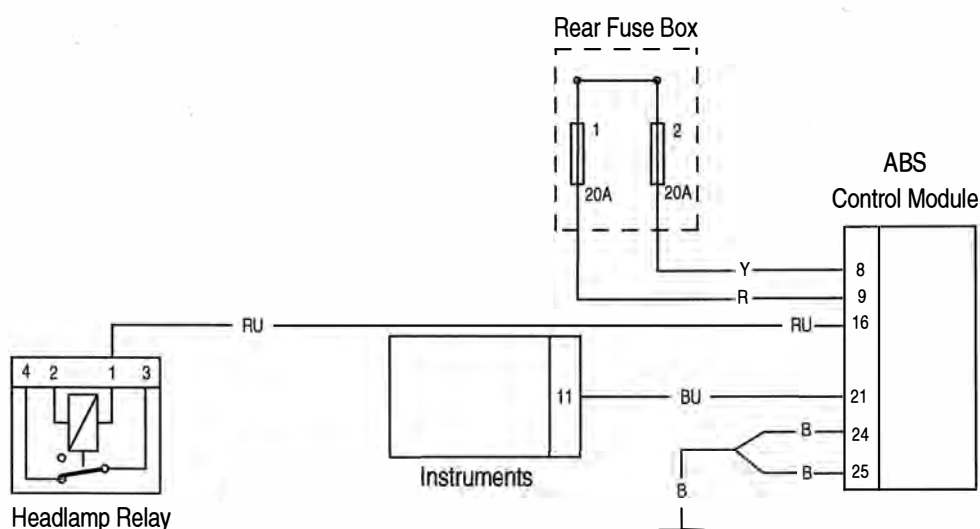

# Brakes

## ABS Warning Light Does Not Illuminate (No DTCs Stored)

Fault Code	Possible cause	Action
ABS Warning Light OFF (No DTCs Stored)	Warning light circuit fault ABS ECM ground circuit fault	Ensure ABS ECM connector is secure. Ensure ABS ECM ground connection is secure. Disconnect ABS ECM connector and proceed to pinpoint test 1:-

### Pinpoint Tests

Test	Result	Action
1 Check cable and terminal integrity: - ABS ECM connector pin 16 and Ground	OK	Proceed to test 2
	Faulty	Rectify fault, proceed to test 6
2 Check the ABS warning light circuit fuse (front fuse box, fuses 1 and 2):	OK	Proceed to test 3
	Faulty	Replace fuse, proceed to test 6
3 Check cable for short to voltage: With Ignition 'OFF', check voltage between - ABS ECM connector pin 16 and Ground	0 V	Proceed to test 4
	Above 3 V	Locate and rectify wiring fault, proceed to test 6
4 Check cable for short to ground: With ignition 'ON', Check the ABS warning light circuit voltage between: - ABS ECM connector pin 21 and Ground	Voltage greater than 1.5 V	Proceed to test 5
	Voltage less than 1.5 V	Locate and rectify fault, proceed to test 6
5 Check cable for continuity: ABS ECM connector pin 24 and Ground: Turn Ignition 'ON'	OK	Proceed to test 6
	Faulty	Locate and rectify fault, proceed to test 6
6 Reconnect ABS ECM harness, clear fault code and test ABS to verify fault cleared	OK	Action complete - quit test
	Fault still present	Contact Triumph service

## Circuit Diagram

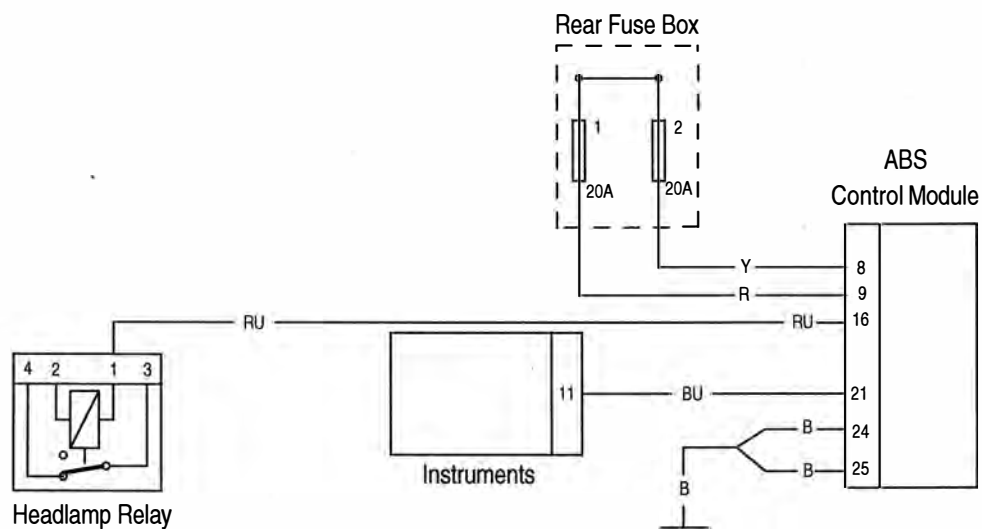

# Brakes

## Front Wheel Sensor Open Circuit/Short Circuit

Fault Code	Possible cause	Action
C1611	Front wheel speed sensor circuit fault	Ensure ABS ECM connector is secure. Ensure wheel speed sensor connector is secure. Disconnect ABS ECM connector and proceed to pinpoint test 1:-

### Pinpoint Tests

Test	Result	Action
1 Check cable and terminal integrity: - ABS ECM connector pin 3 and ABS ECM connector pin 12	OK	Proceed to test 2
	Faulty	Rectify fault, proceed to test 9
2 Check cable for short circuit: - ABS ECM connector pin 12 and Ground	OK	Proceed to test 4
	Short circuit	Proceed to test 3
3 Disconnect the front wheel speed sensor connector. Check cable for short circuit: Wheel speed sensor connector pin 2 (motorcycle harness side) and Ground	OK	Replace the wheel speed sensor, proceed to test 9
	Short circuit	Locate and rectify wiring harness fault, proceed to test 9
4 Check cable for short circuit: - ABS ECM connector pin 3 and Ground	OK	Proceed to test 6
	Short circuit	Proceed to test 5
5 Check cable for short circuit: - Wheel speed sensor connector pin 1 (motorcycle harness side) and Ground	OK	Replace the wheel speed sensor, proceed to test 9
	Short circuit	Locate and rectify wiring harness fault, proceed to test 9
6 Check cable continuity: - ABS ECM connector pin 12 and Wheel speed sensor connector pin 2 (motorcycle harness side)	OK	Proceed to test 7
	Open circuit	Locate and rectify wiring harness fault, proceed to test 9
7 Check cable continuity: - ABS ECM connector pin 3 and Wheel speed sensor connector pin 1 (motorcycle harness side)	OK	Proceed to test 8
	Open circuit	Locate and rectify wiring harness fault, proceed to test 9
8 Reconnect the front wheel speed sensor connector. Check the wheel speed sensor operation: - Connect a suitable voltage supply between 4.5 V and 16 v between ABS ECM connector pin 12 (positive) and pin 3 (negative), and measure the current consumption of the wheel speed sensor	3 mA to 14 mA	Proceed to test 9
	Faulty	Replace the wheel speed sensor, proceed to test 9
9 Reconnect ABS ECM harness, clear fault code and test ABS to verify fault cleared	OK	Action complete - quit test
	Fault still present	Contact Triumph service

## Circuit Diagram

Wheel speed sensor current consumption data under typical conditions:

Voltage	Min	Typical	Max
Low (4.5 V)	3.1 mA	4.1 mA	5.3 mA
High (16V)	8.1 mA	10.5 mA	13.6 mA

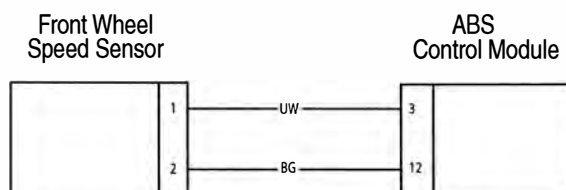

# Brakes

## Rear Wheel Sensor Open Circuit/Short Circuit

Fault Code	Possible cause	Action
C1613	Rear wheel speed sensor circuit fault	Ensure ABS ECM connector is secure. Ensure wheel speed sensor connector is secure. Disconnect ABS ECM connector and proceed to pinpoint test 1:-

### Pinpoint Tests

Test	Result	Action
1 Check cable and terminal integrity: - ABS ECM connector pin 2 and ABS ECM connector pin 18	OK	Proceed to test 2
	Faulty	Rectify fault, proceed to test 9
2 Check cable for short circuit: - ABS ECM connector pin 2 and Ground	OK	Proceed to test 4
	Short circuit	Proceed to test 3
3 Disconnect the front wheel speed sensor connector. Check cable for short circuit: - Wheel speed sensor connector pin 2 (motorcycle harness side) and Ground	OK	Replace the wheel speed sensor, proceed to test 9
	Short circuit	Locate and rectify wiring harness fault, proceed to test 9
4 Check cable for short circuit: - ABS ECM connector pin 18 and Ground	OK	Proceed to test 6
	Short circuit	Proceed to test 5
5 Check cable for short circuit: - Wheel speed sensor connector pin 1 (motorcycle harness side) and Ground	OK	Replace the wheel speed sensor, proceed to test 9
	Short circuit	Locate and rectify wiring harness fault, proceed to test 9
6 Check cable continuity: - ABS ECM connector pin 2 and Wheel speed sensor connector pin 2 (motorcycle harness side)	OK	Proceed to test 7
	Open circuit	Locate and rectify wiring harness fault, proceed to test 9
7 Check cable continuity: - ABS ECM connector pin 18 and Wheel speed sensor connector pin 1 (motorcycle harness side)	OK	Proceed to test 8
	Open circuit	Locate and rectify wiring harness fault, proceed to test 9
8 Reconnect the front wheel speed sensor connector. Check the wheel speed sensor operation: - Connect a suitable voltage supply between 4.5 V and 16 v between ABS ECM connector pin 2 (positive) and pin 18 (negative), and measure the current consumption of the wheel speed sensor	3 mA to 14 mA	Proceed to test 9
	Faulty	Replace the wheel speed sensor, proceed to test 9
9 Reconnect ABS ECM harness, clear fault code and test ABS to verify fault cleared	OK	Action complete - quit test
	Fault still present	Contact Triumph service

## Circuit Diagram

Wheel speed sensor current consumption data under typical conditions:

Voltage	Min	Typical	Max
Low (4.5 V)	3.1 mA	4.1 mA	5.3 mA
High (16V)	8.1 mA	10.5 mA	13.6 mA

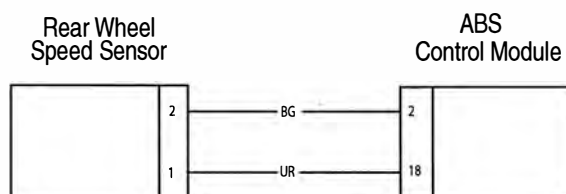

# Brakes

## Front Wheel Sensor Abnormal Input/losing Contact

Fault Code	Possible cause	Action
C1612	Front wheel speed sensor poor signal Incorrect Wheel speed sensor air gap Damaged or dirty pulser ring Loose or incorrectly installed wheel speed sensor	Ensure ABS ECM connector is secure. Ensure wheel speed sensor connector is secure. Proceed to pinpoint test 1:-

### Pinpoint Tests

Test	Result	Action
1 Measure the air gap of the front wheel speed sensor between the sensor and the pulser ring:  -Air gap between 0.1 mm to 1.5 mm	OK	Proceed to test 2
	Faulty	Rectify the fault and proceed to test 5
2 Check the pulser ring for damage or contamination by road grime or ferrous metal filings	OK	Proceed to test 3
	Faulty	Clean or replace the ABS pulser ring, proceed to test 5
3 Check the wheel speed sensors for correct installation, and the fixings for correct torque	OK	Proceed to test 4
	Faulty	Rectify the fault and proceed to test 5
4 Check the wheel speed sensor circuit (See page 14-58)	OK	Contact Triumph service
	Faulty	Rectify the fault and proceed to test 5
5 Clear fault code and test ABS to verify fault cleared	OK	Action complete - quit test
	Fault still present	Contact Triumph service



## Rear Wheel Sensor Abnormal Input/Losing Contact

Fault Code	Possible cause	Action
C1614	Rear wheel speed sensor poor signal Incorrect Wheel speed sensor air gap Damaged or dirty pulser ring Loose or incorrectly installed wheel speed sensor	Ensure ABS ECM connector is secure. Proceed to pinpoint test 1:-

### Pinpoint Tests

Test	Result	Action
1 Measure the air gap of the front wheel speed sensor between the sensor and the pulser ring:  - Air gap between 0.1 mm to 1.5 mm	OK	Proceed to test 2
	Faulty	Rectify the fault and proceed to test 5
2 Check the pulser ring for damage or contamination by road grime or ferrous metal filings	OK	Proceed to test 3
	Faulty	Clean or replace the ABS pulser ring, proceed to test 5
3 Check the wheel speed sensors for correct installation, and the fixings for correct torque:	OK	Proceed to test 4
	Faulty	Rectify the fault and proceed to test 5
4 Check the wheel speed sensor circuit (See page 14-60)	OK	Contact Triumph service
	Faulty	Rectify the fault and proceed to test 5
5 Clear fault code and test ABS to verify fault cleared	OK	Action complete - quit test
	Fault still present	Contact Triumph service

## Brakes

### Front Wheel Pulser Gear Missing Teeth

Fault Code	Possible cause	Action
C1621	Incorrect Wheel speed sensor air gap Damaged or dirty pulser ring Loose or incorrectly installed wheel speed sensor Damaged/incorrect wheels	Ensure ABS ECM connector is secure. Proceed to pinpoint test 1:-

#### Pinpoint Tests

Test	Result	Action
1 Measure the air gap of the front wheel speed sensor between the sensor and the pulser ring:  - Air gap between 0.1 mm to 1.5 mm	OK	Proceed to test 2
	Faulty	Rectify the fault and proceed to test 5
2 Check the pulser ring for damage or contamination by road grime or ferrous metal filings	OK	Proceed to test 3
	Faulty	Clean or replace the ABS pulser ring, proceed to test 5
3 Check the wheel speed sensors for correct installation, and the fixings for correct torque:	OK	Proceed to test 4
	Faulty	Rectify the fault and proceed to test 5
4 Check the motorcycle wheel for damage/incorrect size	OK	Proceed to test 4
	Faulty	Rectify the fault and proceed to test 5
5 Clear fault code and test ABS to verify fault cleared	OK	Action complete - quit test
	Fault still present	Contact Triumph service

## Rear Wheel Pulser Gear Missing Teeth

Fault Code	Possible cause	Action
C1623	Incorrect Wheel speed sensor air gap Damaged or dirty pulser ring Loose or incorrectly installed wheel speed sensor Damaged/incorrect wheels	Ensure ABS ECM connector is secure. Proceed to pinpoint test 1:-

### Pinpoint Tests

Test	Result	Action
1 Measure the air gap of the front wheel speed sensor between the sensor and the pulser ring:  - Air gap between 0.1 mm to 1.5 mm	OK	Proceed to test 2
	Faulty	Rectify the fault and proceed to test 5
2 Check the pulser ring for damage or contamination by road grime or ferrous metal filings	OK	Proceed to test 3
	Faulty	Clean or replace the ABS pulser ring, proceed to test 5
3 Check the wheel speed sensors for correct installation, and the fixings for correct torque:	OK	Proceed to test 4
	Faulty	Rectify the fault and proceed to test 5
4 Check the motorcycle wheel for damage/incorrect size	OK	Proceed to test 4
	Faulty	Rectify the fault and proceed to test 5
5 Clear fault code and test ABS to verify fault cleared.	OK	Action complete - quit test
	Fault still present	Contact Triumph service

# Brakes

## Front or Rear Input/Output Solenoid Open/Short Circuit

Fault Code	Possible cause	Action
Front: C1631; C1632 Rear: C1633; C1634 C1654	ABS solenoid circuit fault	Ensure ABS ECM connector is secure. Disconnect ABS ECM connector and proceed to pinpoint test 1:-

### Pinpoint Tests

Test	Result	Action
1 Check cable and terminal integrity: - ABS ECM connector pin 9 and Ground	OK	Proceed to test 2
	Faulty	Rectify fault, proceed to test 5
2 Check the ABS solenoid fuse (front fuse box fuse 1):	OK	Proceed to test 3
	Faulty	Replace fuse, proceed to test 5
3 Check cable continuity: With Ignition 'ON', check voltage between - ABS ECM connector pin 9 and Ground	Same as 'across battery' voltage	Proceed to test 4
	Less than 'across battery' voltage	Locate and rectify wiring fault, proceed to test 5
4 Check cable for continuity: - ABS ECM connector pin 24 and Ground	OK	Proceed to test 5
	Faulty	Locate and rectify fault, proceed to test 5
5 Clear fault code and test ABS to verify fault cleared	OK	Action complete - quit test
	Fault still present	Contact Triumph service

### Circuit Diagram

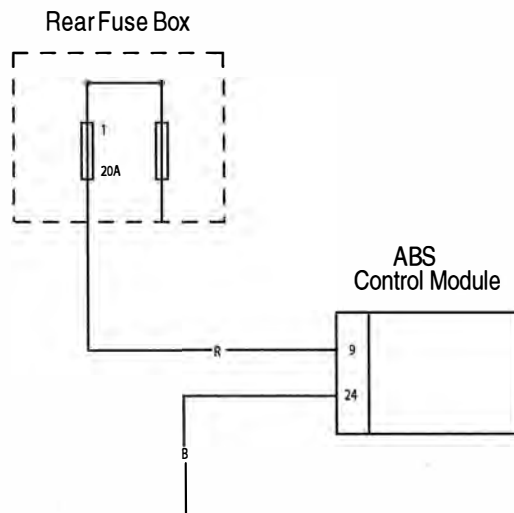

## Front or Rear Wheel Actuator (Hydraulic Control) Wheel Lock

Fault Code	Possible cause	Action
C1641; C1643	Binding brake Incorrect Wheel speed sensor air gap Loose or incorrectly installed wheel speed sensor	Ensure ABS ECM connector is secure. Proceed to pinpoint test 1:

### Pinpoint Tests

Test	Result	Action
1 Check the relevant wheel for brake bind caused by caliper or master cylinder faults, or other mechanical causes	OK	Proceed to test 2
	Faulty	Rectify the fault and proceed to test 4
2 Measure the air gap of the wheel speed sensor between the sensor and the pulser ring: - Air gap between 0.1 mm to 1.5 mm	OK	Proceed to test 3
	Faulty	Rectify the fault and proceed to test 4
3 Check the wheel speed sensors for correct installation, and the fixings for correct torque	OK	Proceed to test 4
	Faulty	Rectify the fault and proceed to test 4
4 Clear fault code and test ABS to verify fault cleared	OK	Action complete - quit test
	Fault still present	Contact Triumph service

# Brakes

## Motor - Lock; Motor Stuck OFF; Motor Stuck ON

Fault Code	Possible cause	Action
C1651; C1652; C1653	Motor circuit fault Motor runs continually Motor does not run at all	Ensure ABS ECM connector is secure. Turn the ignition 'ON'. Proceed to pinpoint test 1:

### Pinpoint Tests

Test	Result	Action
1 Check the motor function: Check that with the motorcycle stationary and the ABS ACM modulator connected, the motor does not operate	OK	Proceed to test 2
	Motor runs continually	Contact Triumph service
2 Check the ABS motor circuit fuse front fuse box, (fuse 2)	OK	Proceed to test 3
	Faulty	Replace fuse and proceed to test 5
3 Check cable continuity: With Ignition 'ON', check voltage between: - ABS ECM connector pin 8 and Ground	Same as 'across battery' voltage	Proceed to test 4
	Less than 'across battery' voltage	Locate and rectify wiring fault, proceed to test 5
4 Check cable for continuity: - ABS ECM connector pin 25 and Ground	OK	Proceed to test 5
	Faulty	Locate and rectify fault, proceed to test 5
5 Reconnect ABS ECM harness, clear fault code and test ABS to verify fault cleared	OK	Action complete - quit test
	Fault still present	Contact Triumph service

### Circuit Diagram

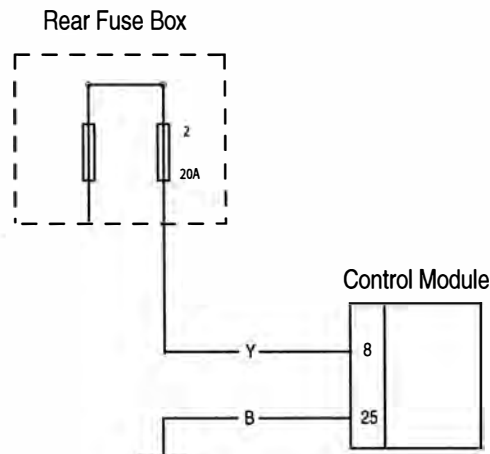

## Power Source Voltage Drop/Voltage Rise

Fault Code	Possible cause	Action
C1661; C1662	Power supply circuit fault Battery charging circuit fault	Ensure ABS ECM connector is secure. Disconnect ABS ECM connector and proceed to pinpoint test 1:

### Pinpoint Tests

Test	Result	Action
1 Check cable and terminal integrity: - ABS ECM connector pin 16 and Ground pin 24	OK	Proceed to test 2
	Faulty	Rectify fault, proceed to test 5
2 Check the cable for continuity: - ABS ECM connector pin 24 and Ground	OK	Proceed to test 3
	Faulty	Rectify wiring harness fault, proceed to test 5
3 Check battery voltage: With ignition 'ON', Check the voltage between: - ABS ECM connector pin 16 and Ground pin 24	Voltage greater than 10 V	Proceed to test 4
	Voltage less than 10 V	Locate and rectify fault, proceed to test 5
4 Check battery voltage: Reconnect ABS ECM connector and start the engine, Check the voltage between: - Battery positive (red) terminal and negative (black) terminal	Voltage between 10 V and 16 V	Proceed to test 4
	Voltage greater than 16 V	Check the battery charging circuit. Locate and rectify fault, proceed to test 5
5 Clear fault code and test ABS to verify fault cleared	OK	Action complete - quit test
	Fault still present	Contact Triumph service

### Circuit Diagram

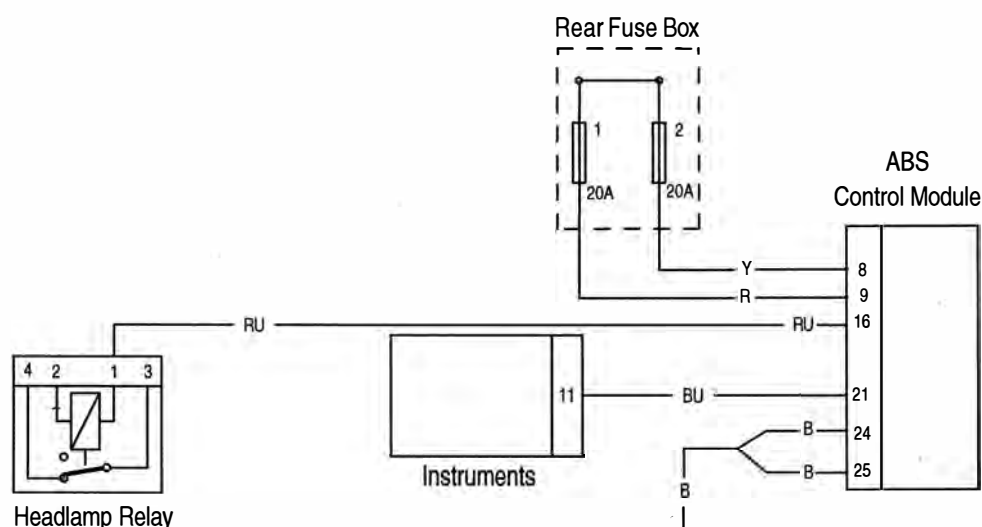

# Brakes

## Different Tyre Diameter

Fault Code	Possible cause	Action
C1671	Incorrect diameter wheels installed Incorrect tyre pressures Incorrect wheel speed sensor air gap Damaged or dirty pulser ring	Ensure ABS ECM connector is secure. Proceed to pinpoint test 1:

### Pinpoint Tests

Test	Result	Action
1 Check for installation of wheels and tyres of the correct size	OK	Proceed to test 2
	Faulty	Rectify fault, proceed to test 5
2 Check the tyre pressures	OK	Proceed to test 3
	Faulty	Rectify fault, proceed to test 5
3 Check the pulser ring for damage or contamination by road grime or ferrous metal filings	OK	Proceed to test 4
	Faulty	Clean or replace the ABS pulser ring, proceed to test 5
4 Measure the air gap of the front wheel speed sensor between the sensor and the pulser ring: - Air gap between 0.1 mm to 1.5 mm	OK	Proceed to test 5
	Faulty	Rectify the fault and proceed to test 5
5 Clear fault code and test ABS to verify fault cleared	OK	Action complete - quit test
	Fault still present	Contact Triumph service



## Abnormal ECU

Fault Code	Possible cause	Action
C1681	Incorrect Wheel speed sensor air gap Damaged or dirty pulser ring Loose or incorrectly installed wheel speed sensor	Ensure ABS ECM connector is secure. Proceed to pinpoint test 1:





### Pinpoint Tests

Test	Result	Action
1 Measure the air gap of the wheel speed sensors between the sensor and the pulser ring: - Air gap between 0.1 mm to 1.5 mm	OK	Proceed to test 1
	Faulty	Rectify the fault and proceed to test 4
2 Check the pulser rings for damage or contamination by road grime or ferrous metal filings	OK	Proceed to test 2
	Faulty	Clean or replace the ABS pulser ring, proceed to test 4
3 Check the wheel speed sensors for correct installation, and the fixings for correct torque	OK	Proceed to test 4
	Faulty	Rectify the fault and proceed to test 4
4 Clear fault code and test ABS to verify fault cleared	OK	Action complete - quit test
	Fault still present	Contact Triumph service

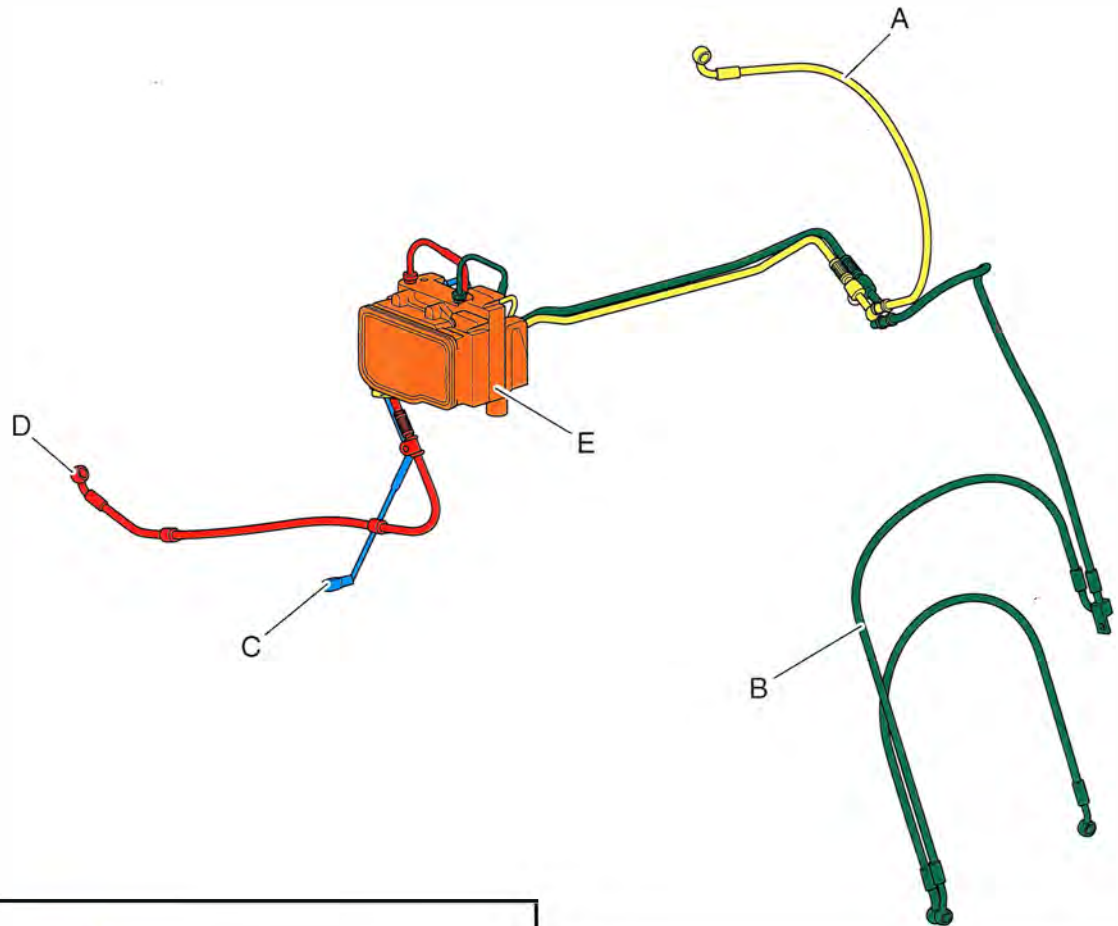
# Brakes

## ABS Hydraulic Circuit Layout



	A. Front Brake Circuit from Master Cylinder to ABS Modulator
	B. Front Brake Circuit from ABS Modulator to Front Calipers
	C. Rear Brake Circuit from Master Cylinder to Modulator
	D. Rear Brake Circuit from ABS Modulator to Rear Caliper
	E. ABS Modulator

# 15 Wheels/Tyres

## Table of Contents

Exploded view - Front Wheel - Tiger 800 .....	15.2
Exploded view - Front Wheel - Tiger 800 XC .....	15.3
Exploded View - Rear Wheel & Final Drive - Tiger 800 .....	15.4
Exploded View - Rear Wheel & Final Drive - Tiger 800 XC .....	15.5
Tyres .....	15.6
Tyre Pressures .....	15.7
Tyre Wear/Wheel Inspection .....	15.8
Important Tyre Information .....	15.8
Front Wheel .....	15.10
Removal .....	15.10
Installation .....	15.11
Rear Wheel .....	15.11
Removal .....	15.11
Installation .....	15.12
Front Wheel Bearings .....	15.13
Removal .....	15.13
Inspection .....	15.14
Installation .....	15.14
Rear Wheel Bearings .....	15.15
Removal .....	15.15
Inspection .....	15.15
Installation .....	15.15
Final Drive .....	15.16
Removal .....	15.16
Inspection .....	15.17
Installation .....	15.17

# Wheels/Tyres

## Exploded view - Front Wheel - Tiger 800

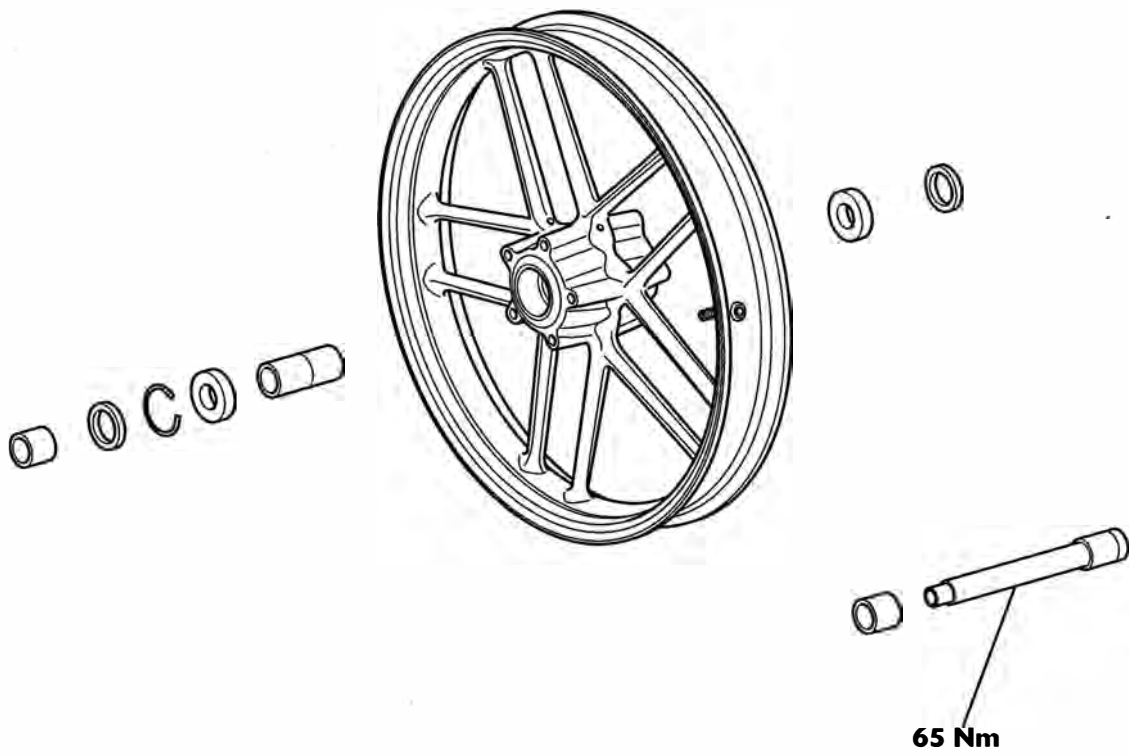

Exploded view - Front Wheel - Tiger 800XC

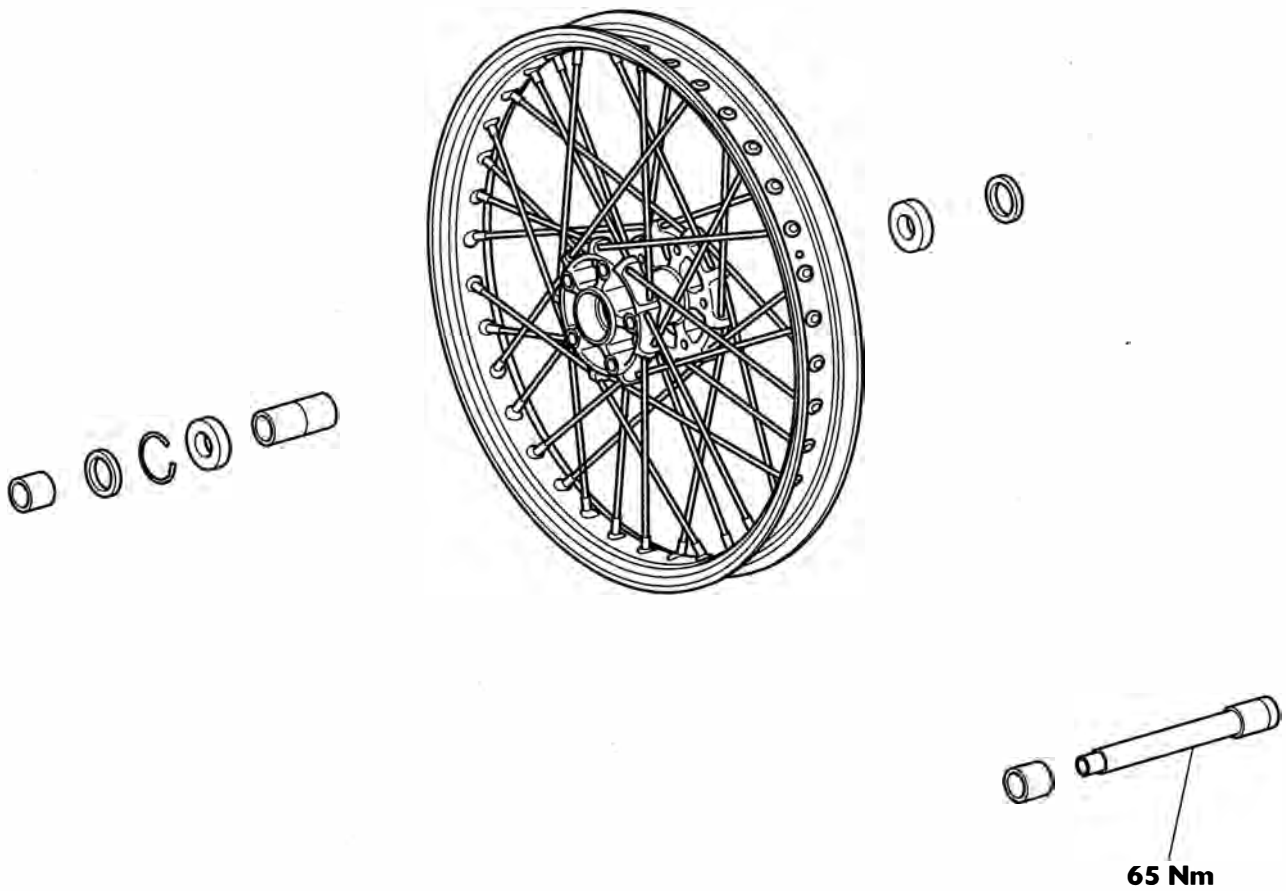

## Exploded View - Rear Wheel & Final Drive - Tiger 800

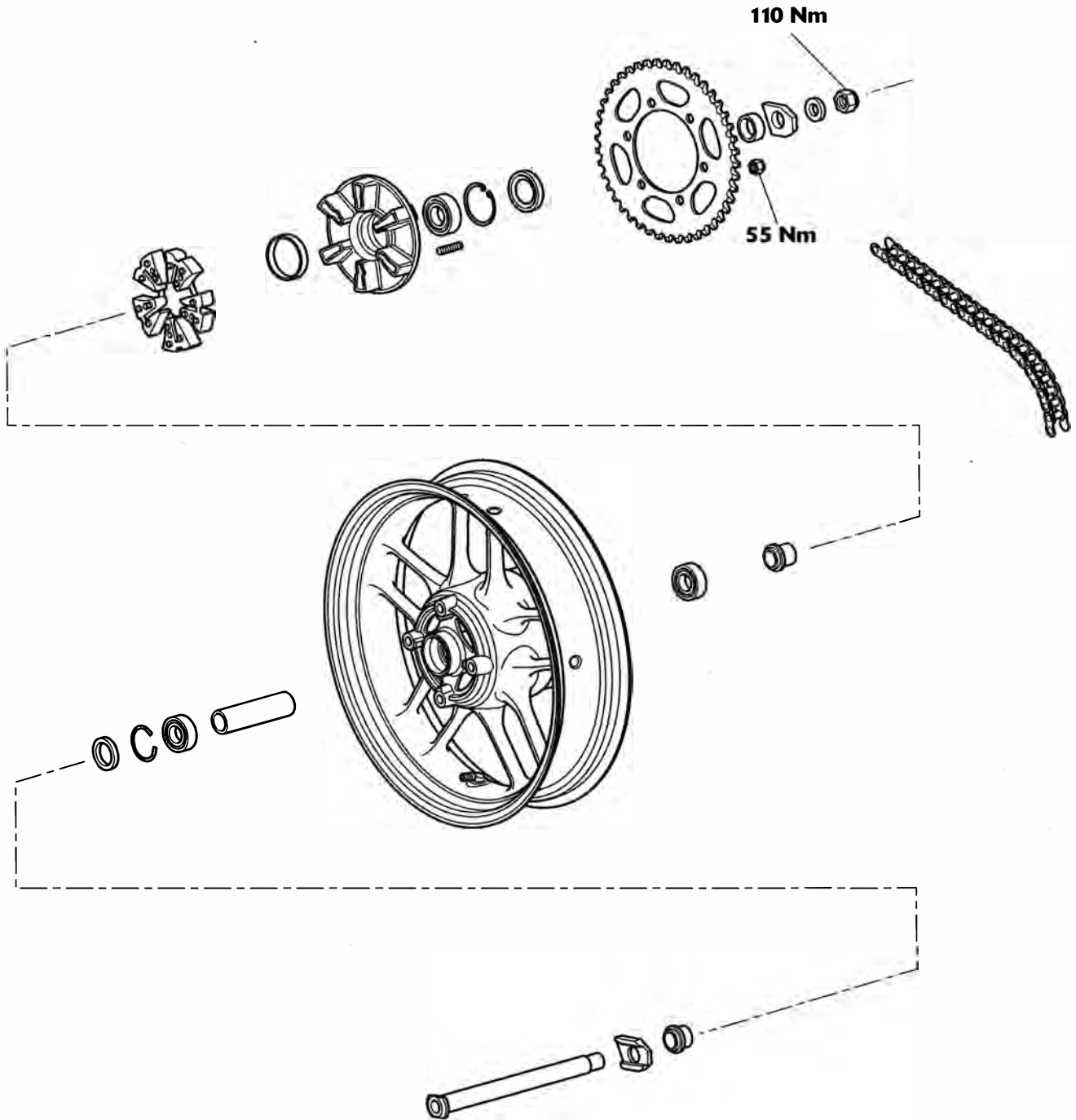

Exploded View - Rear Wheel & Final Drive - Tiger 800XC

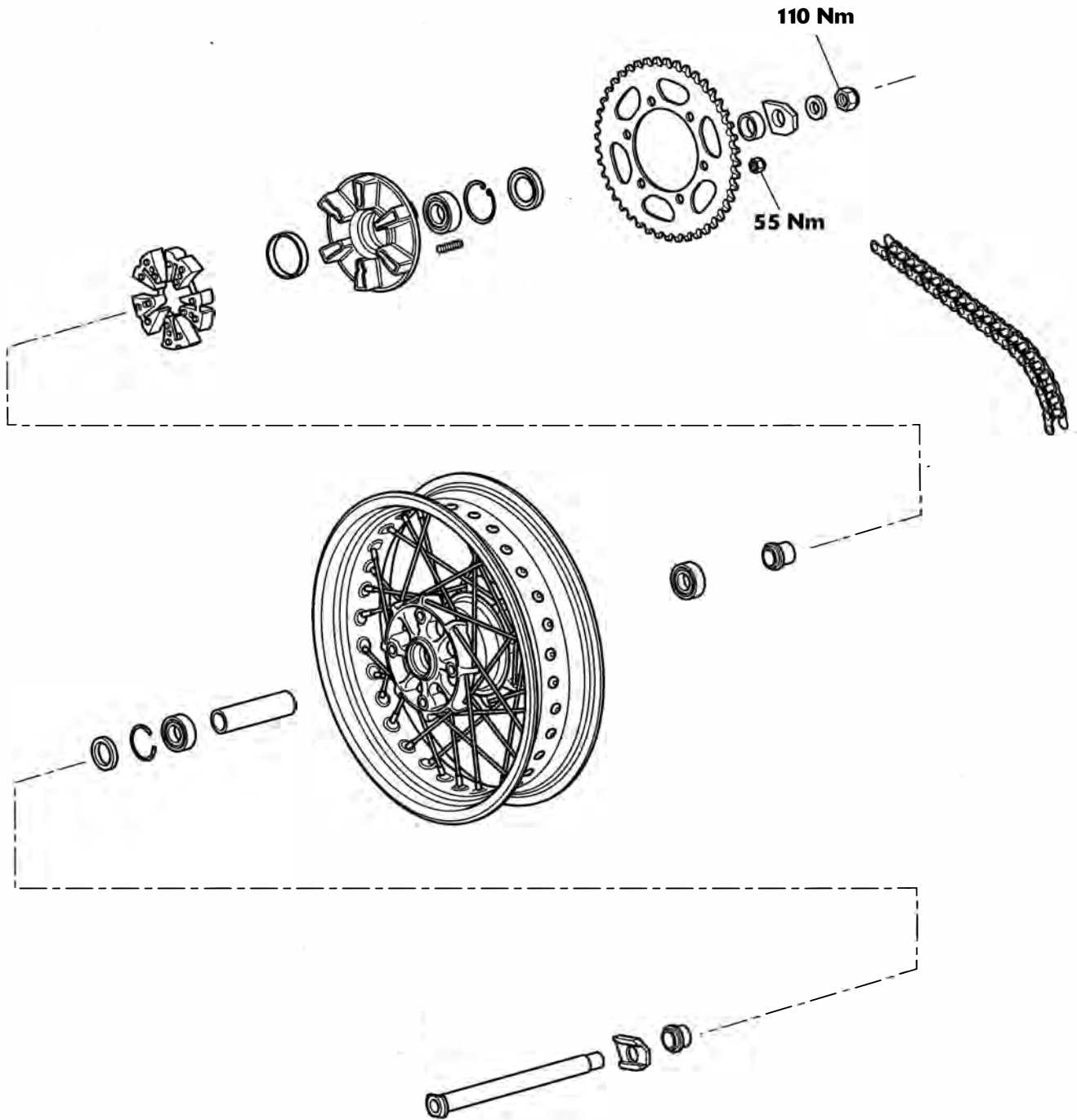

# Wheels/Tyres

## Tyres

Tiger 800 models are equipped with tubeless tyres, valves and wheel rims. Use only tyres marked 'TUBELESS' and tubeless valves on rims marked 'SUITABLE FOR TUBELESS TYRES'.

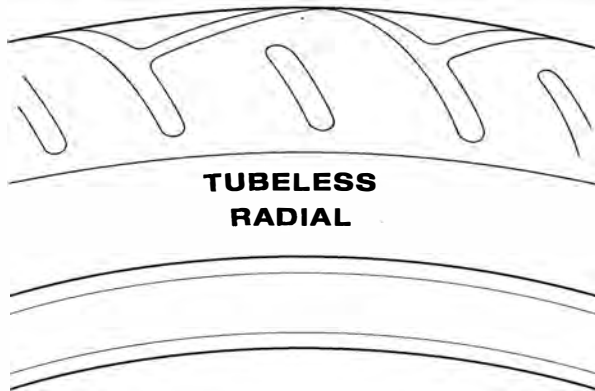

Typical Tyre Marking - Tubeless Tyre

### Warning

Do not install tube-type tyres on tubeless rims. The bead will not seat and the tyres could slip on the rims, causing rapid tyre deflation that may result in a loss of vehicle control and an accident. Never install an inner tube inside a tubeless tyre. This will cause friction inside the tyre and the resulting heat build-up may cause the tube to burst resulting in rapid tyre deflation, loss of vehicle control and an accident.

Tiger 800XC models are fitted with spoked wheels which require a tyre suitable for use with an inner tube.

### Warning

Failure to use an inner tube in a spoked wheel will cause deflation of the tyre resulting in loss of motorcycle control and an accident.

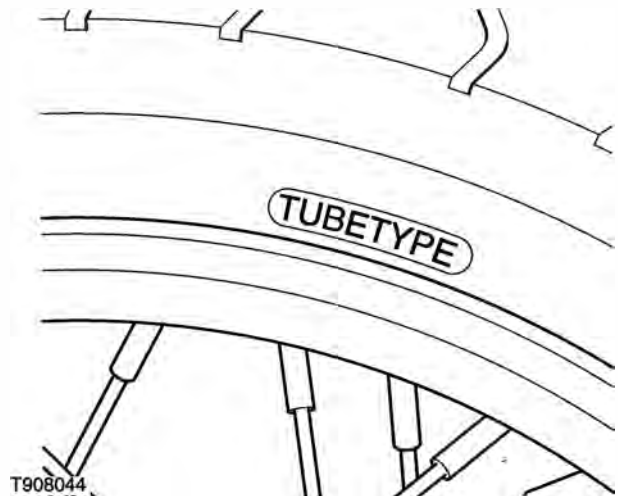

Typical Tyre Marking - Tubed Tyre

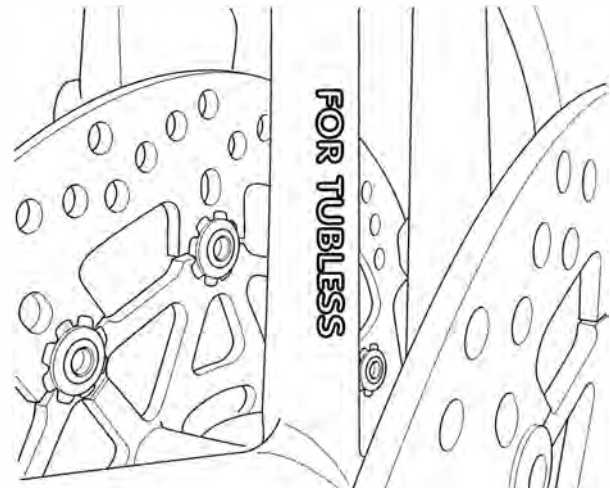

Typical Tyre Marking - Tubeless Wheel



## Warning

Inner tubes must only be used on motorcycles fitted with spoked wheels and with tyres marked 'TUBE TYPE'.

Some brands of approved tyre marked 'TUBELESS' may be suitable for use with an inner tube. Where this is the case, the tyre wall will be marked with text permitting the fitment of an inner tube (see illustration below).

Use of an inner tube with a tyre marked 'TUBELESS', and NOT marked as suitable for use with an inner tube, or use of an inner tube on an alloy wheel marked 'SUITABLE FOR TUBELESS TYRES' will cause deflation of the tyre resulting in loss of motorcycle control and an accident.

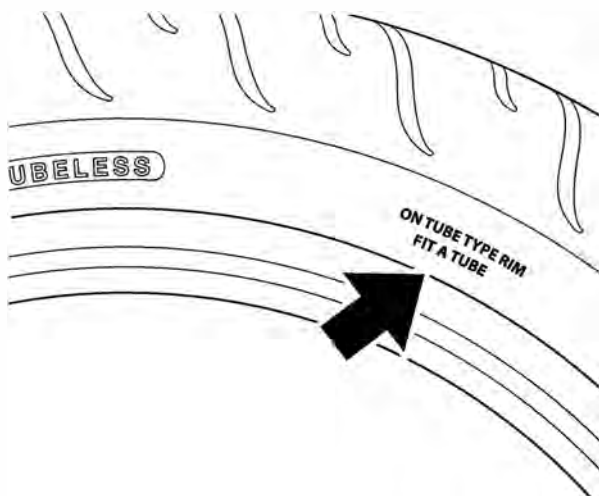

**Typical Tyre Marking - Tubeless Tyre Suitable For Use With An Inner Tube**

## Warning

Tyres that have been used on a rolling road dynamometer may become damaged. In some cases, the damage may not be visible on the external surface of the tyre.

Tyres must be replaced after such use as continued use of a damaged tyre may lead to instability, loss of control and an accident.

## Tyre Pressures

Correct inflation pressure will provide maximum stability, rider comfort and tyre life.

Always check tyre pressures before riding when the tyres are cold. Check tyre pressures daily and adjust if necessary.

Correct on-road tyre pressures are:

### Tiger 800 and Tiger 800XC

Tyre Pressure - Front	2.5 bar (36 psi)
Tyre Pressure - Rear	2.90 bar (42 psi)

## Warning

Tyre pressures which have been reduced for off-road riding will impair on-road stability. Always ensure the tyre pressures are set as described above for on-road use.

Operation of the motorcycle with incorrect tyre pressures may cause loss of motorcycle control leading to an accident.

Correct off-road tyre pressures are:

### Tiger 800XC Only

Tyre Pressure - Front	1.5 bar (22 psi)
Tyre Pressure - Rear	1.5 bar (22 psi)

## Warning

Incorrect tyre inflation will cause abnormal tread wear and instability problems which may lead to loss of control and an accident.

Under-inflation may result in the tyre slipping on, or coming off the rim. Over-inflation will cause instability and accelerated tread wear.

Both conditions are dangerous as they may cause loss of control leading to an accident.

## Warning

Tyre pressures which have been reduced for off-road riding will impair on-road stability. Always ensure the tyre pressure are set as described in the Specification section for on-road use.

Operation of the motorcycle with incorrect tyre pressures may cause loss of motorcycle control leading to an accident.

# Wheels/Tyres

## Tyre Wear/Wheel Inspection

As the tyre tread wears down, the tyre becomes more susceptible to puncture and failure. It is estimated that 90% of all tyre failures occur during the last 10% of tread life (90% worn). It is false economy and unsafe to use tyres until they are worn to their minimum.

All tyres are fitted with tread wear indicators. When the tyre becomes worn down as far as the top of a tread wear indicator, the tyre is worn beyond its service life and must be replaced.

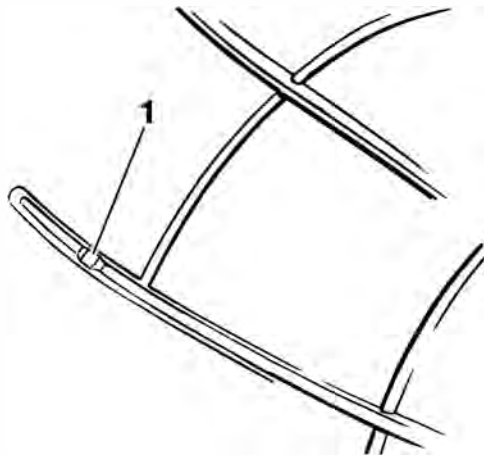

gafj

### 1. Tread wear indicator

In accordance with the scheduled maintenance chart, measure the depth of the tread with a depth gauge, and replace any tyre that has worn to, or beyond the minimum allowable tread depth.

Inspect wheels for cracks, splits and kerb damage. Always replace wheels that are suspected of having become damaged.

### Warning

Operation with excessively worn tyres is hazardous and will adversely affect traction, stability and handling which may lead to loss of control or an accident.

When tyres become punctured, leakage is often very slow. Always inspect tyres very closely for punctures.

Check the tyres for cuts, embedded nails or other sharp objects.

Check the rims for dents or deformation and spokes for looseness and damage. Operation with damaged or defective wheels, spokes or tyres is dangerous and loss of control or an accident could result.

Always consult your Triumph dealer for tyre replacement, or for a safety inspection of the tyres.

## Minimum Recommended Tread Depth

The following chart can be used as a guide to the minimum safe tread depth.

Under 130 km/h (80 mph)	2 mm (0.08 in)
Over 130 km/h (80 mph)	Rear 3 mm (0.12 in) Front 2 mm (0.08 in)

### Warning

Triumph motorcycles must not be operated above the legal road speed limit except in authorised closed course conditions.

## Important Tyre Information

All Triumph motorcycles are carefully and extensively tested in a range of riding conditions to ensure that the most effective tyre combinations are approved for use on each model. It is essential that approved tyres and inner tubes (if installed) fitted in approved combinations, are used when purchasing replacement items. The use of non-approved tyres and inner tubes, or approved tyres and inner tubes in non-approved combinations, may lead to motorcycle instability, loss of control and an accident.

On models fitted with ABS, different wheel speeds, caused by non-approved tyres, can affect the function of the ABS computer.

See the Specification section for details of approved tyre and inner tube combinations. Always have tyres and inner tubes fitted and balanced by your authorised Triumph dealer who has the necessary training and skills to ensure safe, effective fitment.

### Warning

If a tyre or inner tube sustains a puncture, the tyre and inner tube must be replaced. Failure to replace a punctured tyre and inner tube, or operation with a repaired tyre can lead to instability, loss of control or an accident.

Never use an inner tube to repair a punctured tyre. The rough surface inside the tyre can chafe the tube leading to instability, rapid deflation, loss of control and an accident.

## Warning

The use of tyres other than those listed in the specification section of the owner's handbook may adversely affect handling leading to loss of control or an accident.

Use the recommended tyre options only in the combinations given in the owner's handbook.

Do not mix tyres from different manufacturers or tyres from the same manufacturer but from another option.

## Warning

Always check tyre pressures before riding when the tyres are cold. Operation with incorrectly inflated tyres may affect handling leading to loss of control and an accident.

## Warning

Operation with excessively worn or damaged tyres will adversely affect handling and control leading to loss of control or an accident.

## Warning

Do not install tube-type tyres on tubeless rims. The bead will not seat and the tyres could slip on the rims, causing tyre deflation that may result in a loss of vehicle control and an accident.

Do not install an inner tube inside a tubeless tyre. This may cause instability and excessive heat build-up may cause the tube to burst resulting in rapid tyre deflation, loss of vehicle control and an accident.

## Warning

Accurate wheel balance is necessary for safe, stable handling of the motorcycle. Do not remove or change any wheel balance weights. Incorrect wheel balance may cause instability leading to loss of control and an accident.

When wheel balancing is required, such as after tyre replacement, see your authorised Triumph dealer.

Only use self-adhesive weights. Clip on weights will damage the wheel and tyre resulting in tyre deflation, loss of control and an accident.

## Warning

When replacement tyres or inner tubes are required, consult your authorised Triumph dealer who will arrange for the tyres and inner tubes to be selected, in a correct combination, from the approved list and fitted according to the tyre and inner tube manufacturer's instructions.

When tyres and inner tubes are replaced, allow time for the tyres and inner tubes to seat to the rim (approximately 24 hours). During this seating period, ride cautiously as an incorrectly seated tyre or inner tube could cause instability, loss of motorcycle control and an accident.

Initially, the new tyres and inner tubes will not produce the same handling characteristics as the worn tyres and inner tubes and the rider must allow adequate riding distance (approximately 100 miles) to become accustomed to the new handling characteristics.

24 hours after fitting, the tyre pressures must be checked and adjusted, and the tyres and inner tubes examined for correct seating. Rectification must be carried out as necessary.

The same checks and adjustments must also be carried out when 100 miles have been travelled after fitting.

Use of a motorcycle with incorrectly seated tyres or inner tubes, incorrectly adjusted tyre pressures, or when not accustomed to its handling characteristics may lead to loss of motorcycle control and an accident.

### Note:

- **Some brands of approved tyre marked 'TUBELESS' may be suitable for use with an inner tube. Where this is the case, the tyre wall will be marked with text permitting the fitment of an inner tube.**

# Wheels/Tyres

## Front Wheel

### Removal

#### Warning

Before starting work, ensure the motorcycle is stabilised and adequately supported. This will help prevent it from falling and causing injury to the operator or damage to the motorcycle.

1. Position the motorcycle on a paddock stand.
2. Raise and support the front of the motorcycle.

#### Warning

Do not allow the calipers to hang on the brake hoses as this may damage the hoses.  
Damaged hoses could cause brake failure leading to loss of control and an accident.

3. Detach and support the front brake calipers (see page 14-16).

#### Note:

- It is not necessary to disconnect the brake hoses.

4. Slacken both pinch bolts at the lower end of the right hand fork.

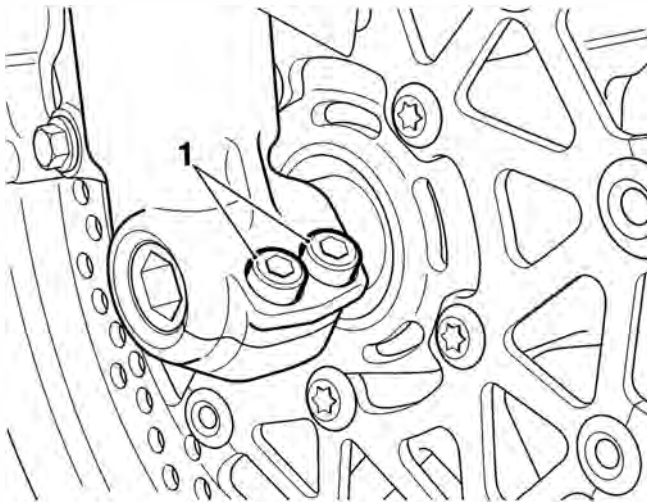

1. Fork pinch bolts

5. Release and remove the wheel spindle, which is threaded into the left hand fork.
6. Remove the wheel and the wheel spacers.

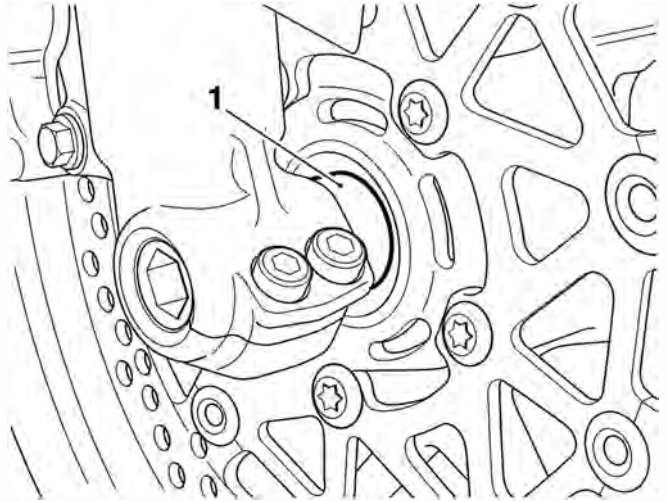

1. Wheel spacers (right hand shown)

7. Place the wheel on wooden blocks.

#### Warning

Do not allow the wheel to rest on either brake disc as this may damage the disc and could lead to an accident.

#### Caution

To prevent wheel and bearing damage, observe absolute cleanliness and ensure there is no dirt ingress to the wheel bearings while the wheel is removed.

8. Thoroughly clean all components and inspect for wear or damage.

## Installation

1. Lightly smear the wheel spacers with grease and locate in the hubs.
2. Position the wheel between the forks ensuring the spacers remain in position on both sides.

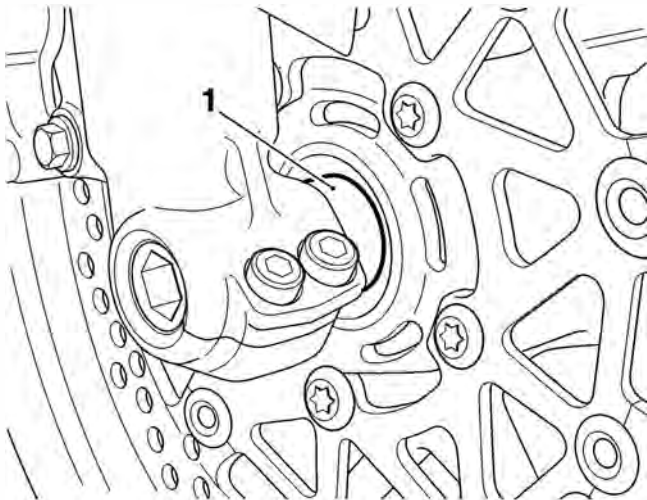

### 1. Wheel spacers (right hand shown)

3. Refit the wheel spindle from the right hand side and tighten to **65 Nm**.
4. Lower the motorcycle to the ground and pump the front suspension to allow the left hand fork to 'float' to its natural position on the wheel spindle.
5. Check that the brake disc is centrally located to the caliper on the left hand side. If not, apply gentle pressure to the fork to ensure the disc is centred with the caliper.
6. Maintaining the above position, tighten the fork pinch bolts to **22 Nm**.

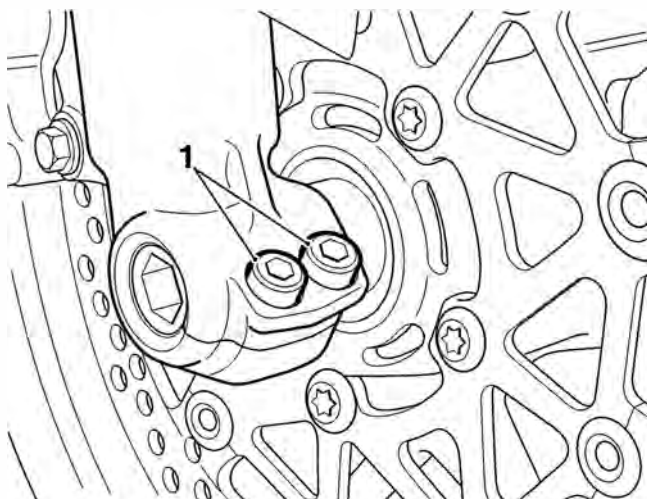

### 1. Fork pinch bolts

7. Thoroughly clean and degrease the brake discs.
8. Refit the front brake calipers (see page 14-18).



## Warning

It is dangerous to operate the motorcycle with defective brakes; you must have your authorised Triumph dealer take remedial action before you attempt to ride the motorcycle again. Failure to take remedial action may reduce braking efficiency leading to loss of motorcycle control and an accident.

9. Check the operation of the front brake.

# Wheels/Tyres

## Rear Wheel

### Removal

#### Warning

Before starting work, ensure the motorcycle is stabilised and adequately supported. This will help prevent it from falling and causing injury to the operator or damage to the motorcycle.

1. Raise and support the rear of the motorcycle to allow removal of the rear wheel.

#### Warning

If the engine has recently been running, the exhaust system will be hot. Before working on or near the exhaust system, allow sufficient time for the exhaust system to cool as touching any part of a hot exhaust system could cause burn injuries.

2. Remove and discard the nut from the rear wheel spindle. Collect the left hand chain adjuster block.

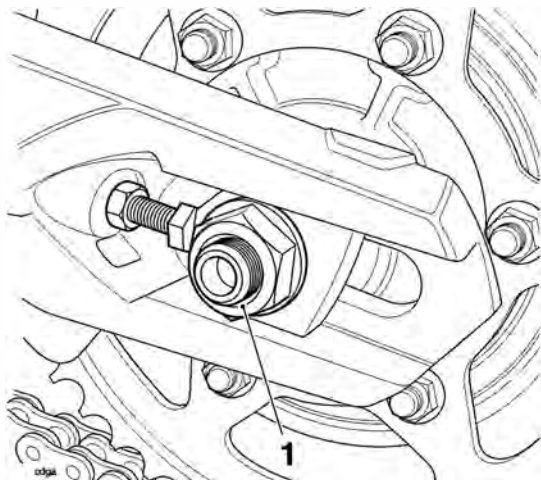

#### 1. Rear wheel spindle nut

3. Support the wheel and withdraw the wheel spindle. Collect the right hand chain adjuster block from the spindle.
4. Roll the wheel forward until the chain can be detached from the rear sprocket.
5. The rear caliper and caliper carrier will remain in position on the swinging arm when the wheel is removed.

#### Warning

Do not allow the caliper to hang on the brake hose as this may damage the hose.

Damaged hoses could cause brake failure leading to loss of control and an accident.

6. Withdraw the wheel and collect the flanged spacer from the right hand side and the plain spacer from the left hand side.
7. Place the wheel on wooden blocks with the drive sprocket uppermost.
8. Remove the final drive. (See page 15-17).
9. Reposition the wheel on wooden blocks with the rear brake disc uppermost.
10. If required, remove the rear brake disc and discard the disc bolts.
11. If required, remove the rear caliper and caliper carrier from the swinging arm.

### Installation

1. Thoroughly clean and degrease the brake disc.
2. Fit the brake disc and tighten new disc bolts to **22 Nm**.
3. Refit the final drive assembly (See page 15-17).
4. Position the wheel within the swinging arm and refit the chain to the final drive sprocket.

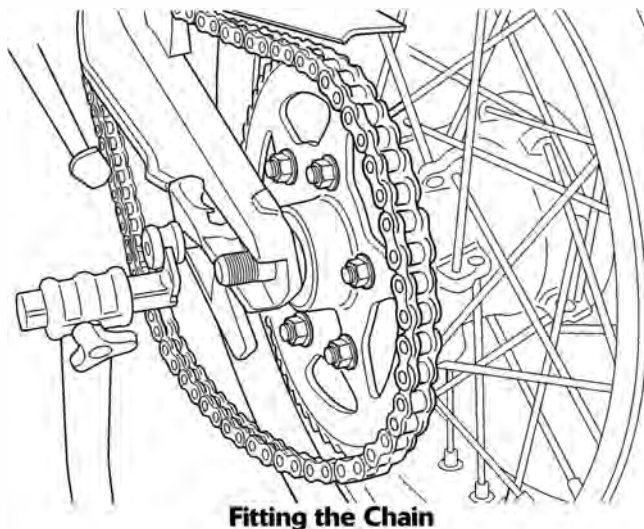

- Position the rear brake caliper and carrier to the swinging arm as noted prior to removal. Align the boss on the swinging arm with the slot on the carrier.

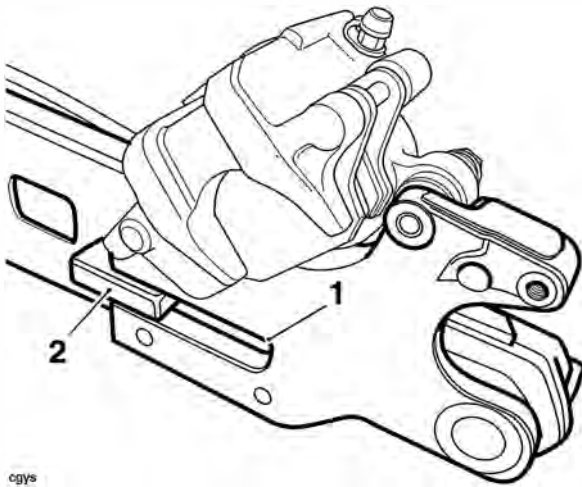

cgys

- Caliper carrier slot
- Swinging arm boss

- Refit the wheel spacers, flanged spacer to the right hand side (flange facing outwards) and plain spacer to the left.

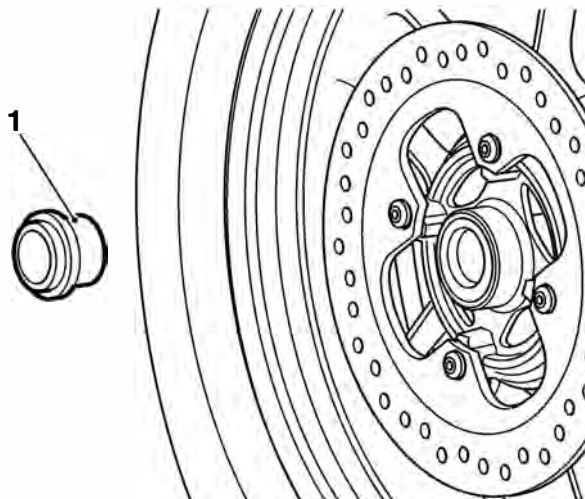

- Wheel spacer (right hand shown)

- Lift the rear wheel into position, aligning the wheel, caliper carrier and swinging arm.

## Warning

Check that the spacers are still correctly positioned. Incorrectly fitted wheel spacers will cause a dangerous riding condition leading to loss of motorcycle control and an accident.

- Ensure the right hand chain adjuster block is installed on the wheel spindle.
- Fit the wheel spindle with the threaded end facing to the left.

- Fit the left hand chain adjuster block and a new rear wheel spindle nut.
- Keeping the chain adjuster blocks in contact with the adjuster bolts, tighten the wheel spindle nut to **110 Nm**.

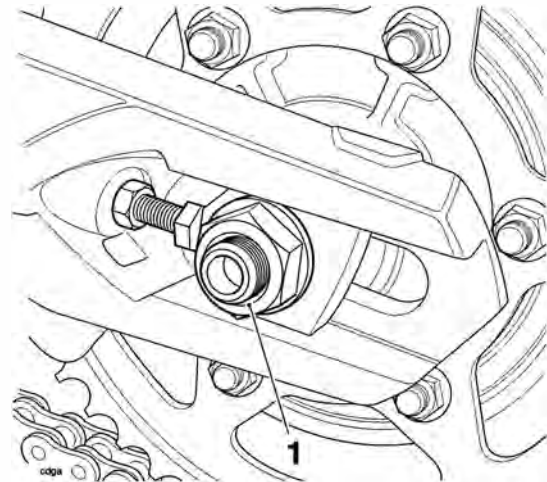

- Rear wheel spindle nut

- Lower the motorcycle to the ground.

## Warning

It is dangerous to operate the motorcycle with defective brakes; you must have your authorised Triumph dealer take remedial action before you attempt to ride the motorcycle again. Failure to take remedial action may reduce braking efficiency leading to loss of motorcycle control and an accident.

- Check the operation of the rear brake.
- Check and, if necessary, adjust the chain (see page 12-8).

## Front Wheel Bearings

### Removal

1. Remove the front wheel (see page 15-10).

#### ! Caution

Do not allow the wheel to rest on the brake discs, as this may damage the discs. Support the wheel on wooden blocks, equally spaced around the rim, such that the brake discs are raised above the ground.

2. Place the wheel on wooden blocks to prevent damage to the brake discs.
3. Remove and discard the seals and the bearing circlip.

#### ! Warning

Always wear eye, hand and face protection when using a hammer and drift. Use of a hammer and drift can cause bearings to fragment. Pieces of fragmented bearing could cause eye and soft tissue injuries if suitable protective apparel is not worn.

#### ! Caution

To prevent wheel damage and to aid bearing removal, always apply force evenly on both sides of the bearing to prevent it from 'tipping' and becoming stuck. Application of uneven force will lead to difficulty in removing the bearing and to a damaged wheel.

4. Using a suitable pin punch, through the centre of the wheel, drift out the wheel bearings. Collect the centre sleeve.

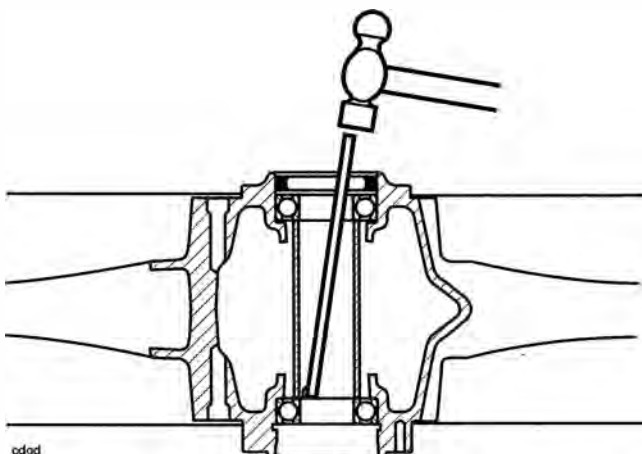

Wheel Bearing Removal

### Inspection

#### ! Warning

Only remove raised witness marks from within the wheel. Removal of material below any raised areas will reduce the level of interference between the wheel and the bearings. Loss of interference could cause the bearing to become loose in the wheel leading to loss of motorcycle control and an accident.

1. Examine the wheel for any raised witness marks caused by the removal process. Remove any such marks with fine emery paper or a gentle file.

### Installation

#### Note:

- Refer to the chart below for the correct tool and tool face when inserting bearings. Bearings are inserted by means of a draw-bolt acting on the insertion tool. A support tool is located on the opposite side of the wheel to the insertion tool and as the bolt is tightened, the bearing is drawn into the wheel.
- Insert bearings with the marked or shielded side facing outwards and always fit a new bearing circlip and seals.

	Bearing insertion tool	Support tool
Left bearing	T3880053 Large face to bearing	3880070 - T0301 Large face to Wheel
Right bearing	T3880053 Large face to bearing	3880070 - T0301 Large face to wheel



1. Fit the wheel bearings and centre sleeve using the method described opposite.

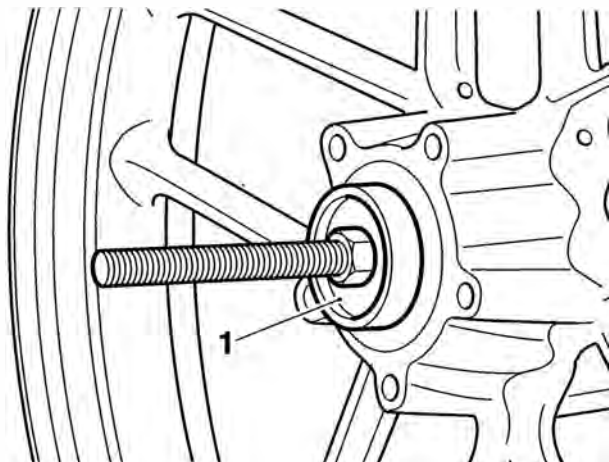

### 1. Tool T388053

2. Fit a new circlip.
3. Lubricate and fit new seals to the front wheel. Lubricate the seal's knife-edge with grease to NLGI 2 specification (we recommend Mobil HP222).
4. Fit the front wheel (see page 15-11).

## Rear Wheel Bearings

### Removal

1. Remove the rear wheel (see page 15-12).

### ! Caution

Do not allow the wheel to rest on the brake disc, as this may damage the disc. Support the wheel on wooden blocks, equally spaced around the rim, such that the brake disc is raised above the ground.

2. Place the wheel on wooden blocks to prevent damage to the brake disc.
3. Remove and discard the seals and the bearing circlip.

### ! Warning

Always wear eye, hand and face protection when using a hammer and drift. Use of a hammer and drift can cause bearings to fragment. Pieces of fragmented bearing could cause eye and soft tissue injuries if suitable protective apparel is not worn.

### ! Caution

To prevent wheel damage and to aid bearing removal, always apply force evenly on both sides of the bearing to prevent it from 'tipping' and becoming stuck. Application of uneven force will lead to difficulty in removing the bearing and to a damaged wheel.

4. Using a suitable pin punch, through the centre of the wheel, drift out the wheel bearings. Collect the centre sleeve.

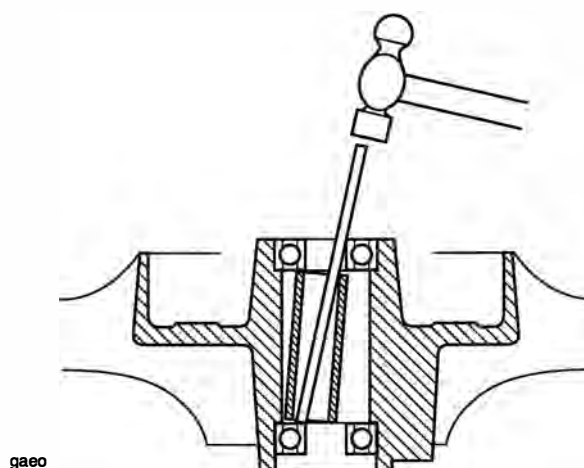

Rear Wheel Bearing Removal

## Inspection

**! Warning**

Only remove raised witness marks from within the wheel. Removal of material below any raised areas will reduce the level of interference between the wheel and the bearings. Loss of interference could cause the bearing to become loose in the wheel leading to loss of motorcycle control and an accident.

1. Examine the wheel for any raised witness marks caused by the removal process. Remove any such marks with fine emery paper or a gentle file.

## Installation

### Note:

- Refer to the chart below for the correct tool and tool face when inserting bearings. Bearings are inserted by means of a draw-bolt acting on the insertion tool. A support tool is located on the opposite side of the wheel to the insertion tool and as the bolt is tightened, the bearing is drawn into the wheel.
- Insert bearings with the marked or shielded side facing outwards and always fit a new bearing circlip and seals.

	Bearing insertion tool	Support tool
Left bearing	T3880053 Large face to bearing	3880070 - T0301 Large face to Wheel
Right bearing	T3880053 Large face to bearing	3880070 - T0301 Large face to wheel

1. Fit the wheel bearings and centre sleeve using the method described on the previous page.

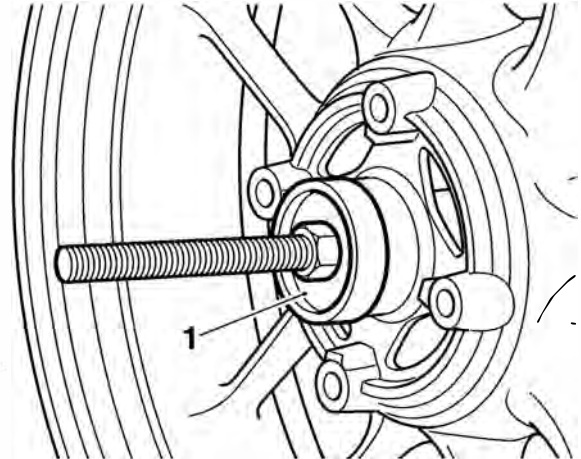

### 1. Tool T3880053

2. Fit a new circlip.
3. Lubricate and fit new seals to the rear wheel. Lubricate the seal's knife-edge with grease to NLGI 2 specification (we recommend Mobil HP222).
4. Fit the rear wheel (see page 15-12).

## Final Drive

### Removal

#### **Warning**

Before starting work, ensure the motorcycle is stabilised and adequately supported. This will help prevent it from falling and causing injury to the operator or damage to the motorcycle.

1. Remove the rear wheel (see page 15-12).

#### **Caution**

Do not allow the wheel to rest on the brake disc, as this may damage the disc. Support the wheel on wooden blocks, equally spaced around the rim, such that the brake disc is raised above the ground.

2. Place the wheel on wooden blocks with the drive sprocket uppermost.
3. Gently lever the drive flange from the wheel hub.

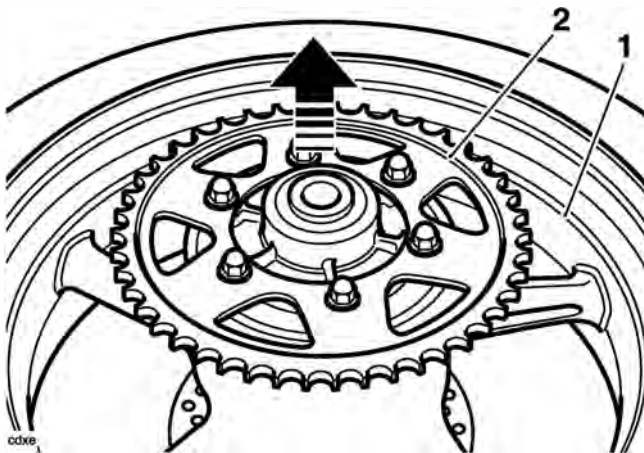

1. Rear wheel
2. Drive flange

4. Remove the cush drive rubber.

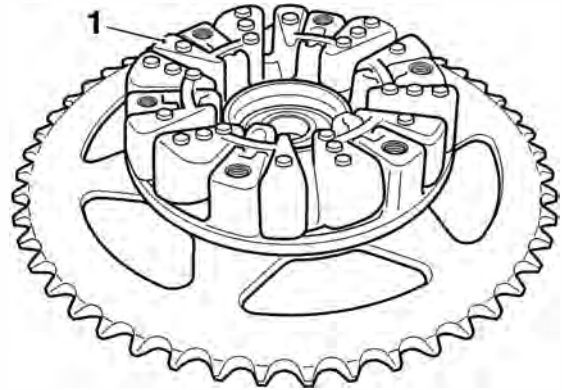

1. Cush drive rubber

### Inspection

1. Check the cush drive rubbers for deterioration, cracks etc.
2. Inspect the sprocket teeth for wear, damage and chips.
3. Check the wheel and drive flange for wear, cracks and damage.

### Installation

1. Install the cush drive rubbers to the wheel.
2. Refit the drive flange to the wheel.
3. Refit the rear wheel (see page 15-12).

This page intentionally left blank

# 16 Frame and Bodywork

## Table of Contents

Exploded View - Frame - all Models .....	16.3
Exploded View - Cockpit and Mountings - Tiger 800 .....	16.4
Exploded View - Cockpit and Mountings - Tiger 800 XC .....	16.5
Exploded View - Lower Panels and Sumpguard - all Models .....	16.6
Exploded View - Rear Panels - all Models .....	16.7
Exploded View - Footrests and Mountings - all Models .....	16.8
Exploded View - Sidestand - all Models .....	16.9
Exploded View - Front Mudguard - Tiger 800 .....	16.10
Exploded View - Front Mudguard - Tiger 800 XC .....	16.11
Exploded View - Rear Mudguard - all Models .....	16.12
Rear Seat .....	16.13
Removal .....	16.13
Rider's Seat .....	16.13
Removal .....	16.13
Lower Radiator Panel .....	16.14
Removal .....	16.14
Installation .....	16.14
Upper Radiator Panel .....	16.14
Removal .....	16.14
Installation .....	16.15
Radiator Infill Panel .....	16.15
Removal .....	16.15
Installation .....	16.16
Beak - Tiger 800 XC only .....	16.16
Removal .....	16.16
Installation .....	16.16
Cockpit Assembly .....	16.17
Removal .....	16.17
Disassembly .....	16.17
Assembly .....	16.18
Installation .....	16.18
Fuel Tank Infill Panel .....	16.18

## Frame and Bodywork

---

Removal .....	16.18
Installation .....	16.18
Windscreen .....	16.19
Removal .....	16.19
Installation .....	16.19
Front Mudguard - Tiger 800 .....	16.19
Removal .....	16.19
Installation .....	16.19
Front Mudguard - Tiger 800 XC .....	16.20
Removal .....	16.20
Installation .....	16.20
Rear Rack .....	16.20
Removal .....	16.20
Installation .....	16.20
Rear Side Panel .....	16.21
Removal .....	16.21
Installation .....	16.21
Rear Mudguard .....	16.22
Removal .....	16.22
Installation .....	16.23
Sump Guard .....	16.24
Removal .....	16.24
Installation .....	16.24
Frame, Footrests and Fixings .....	16.24
Inspection .....	16.24

Exploded View - Frame - all Models

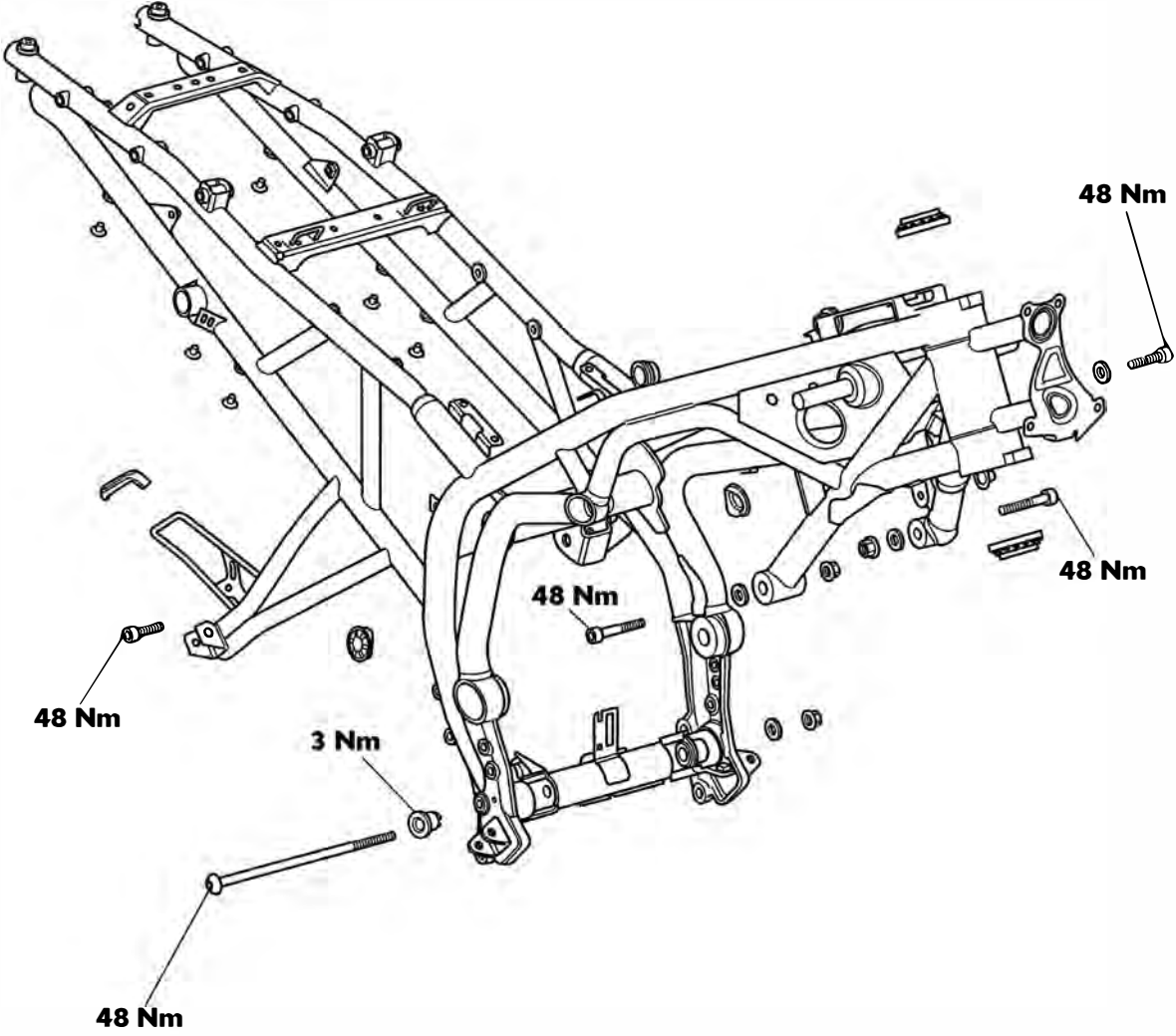

# Frame and Bodywork

## Exploded View - Cockpit and Mountings - Tiger 800

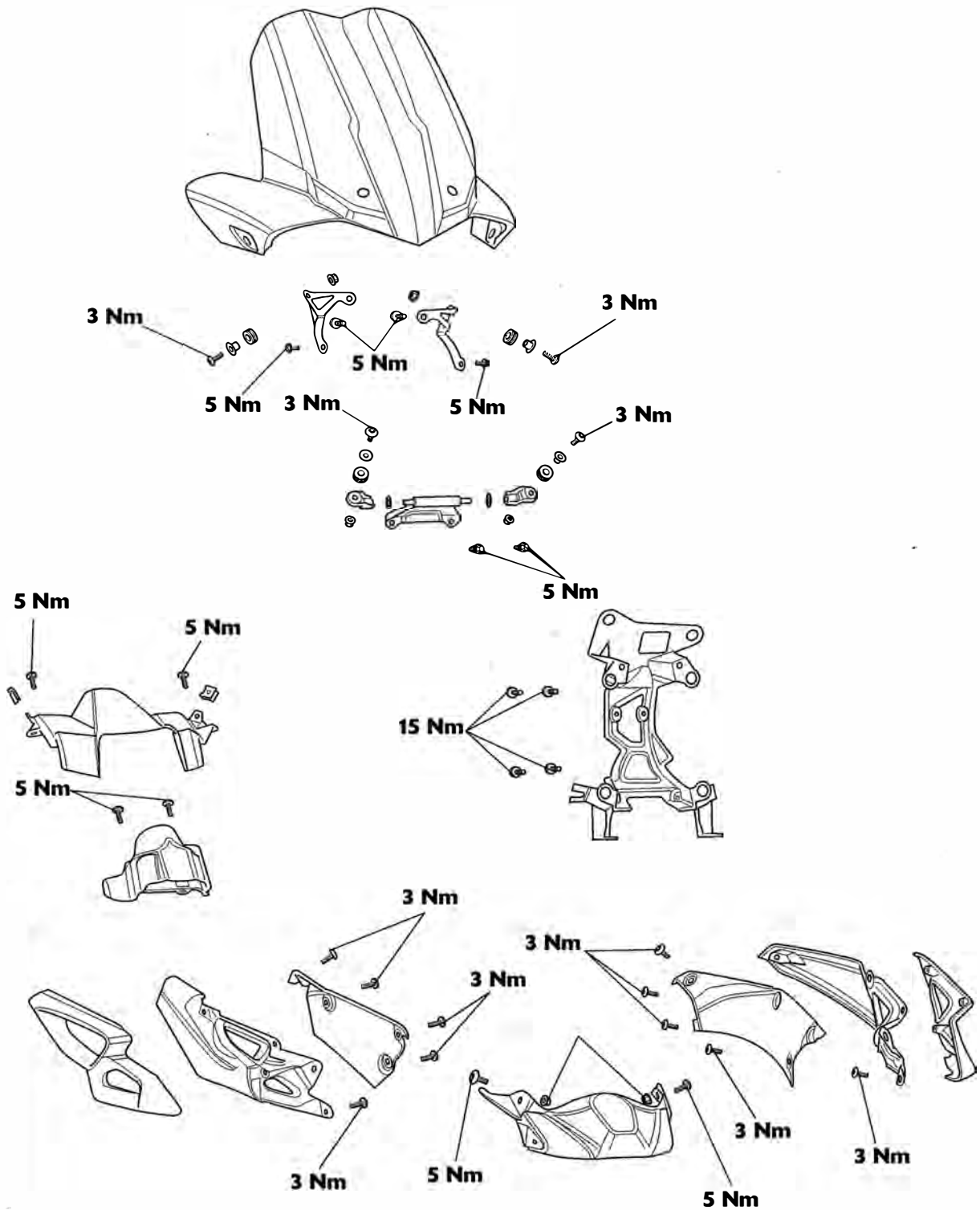



Exploded View - Cockpit and Mountings - Tiger 800XC

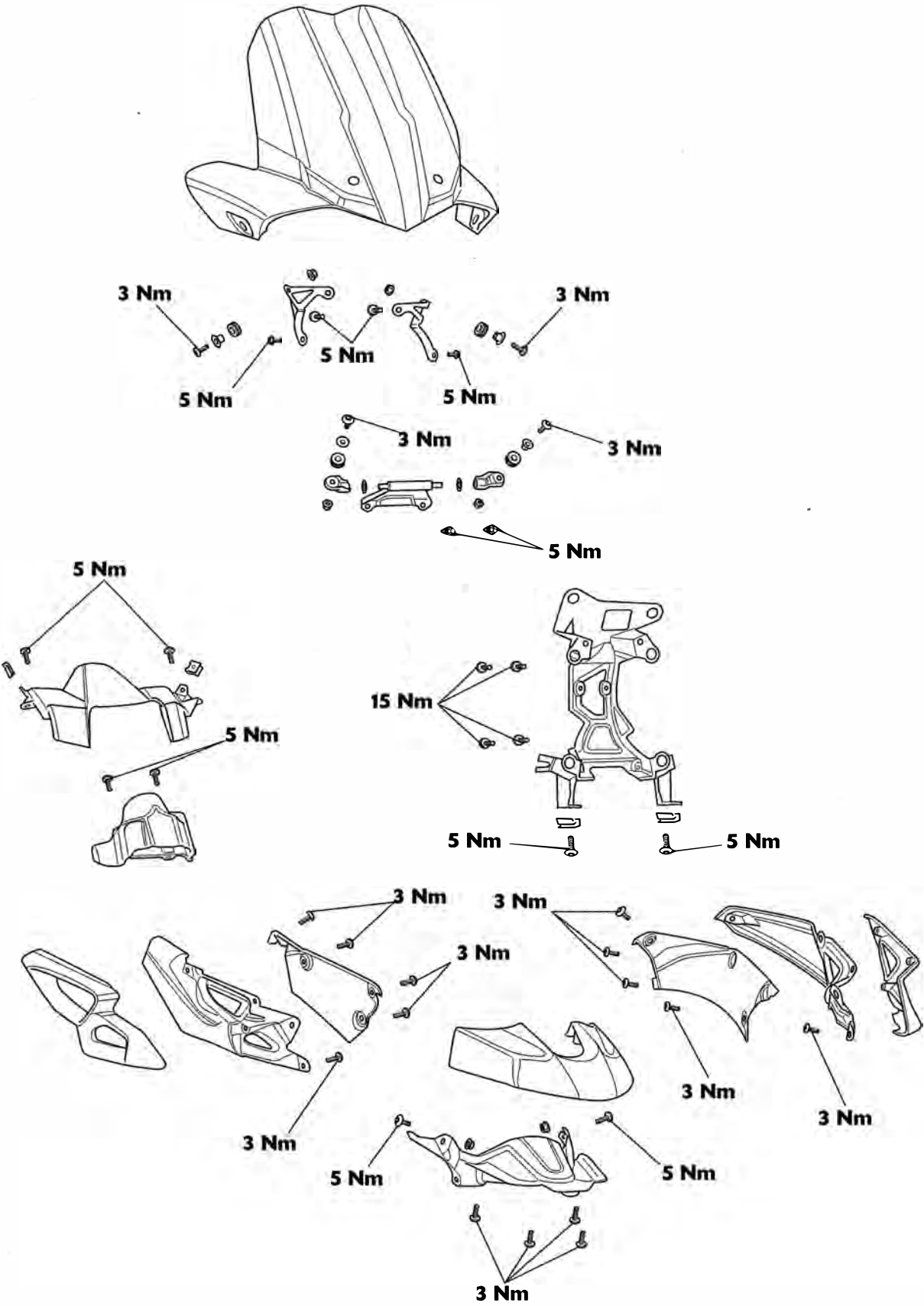

# Frame and Bodywork

## Exploded View - Lower Panels and Sumpguard - all Models

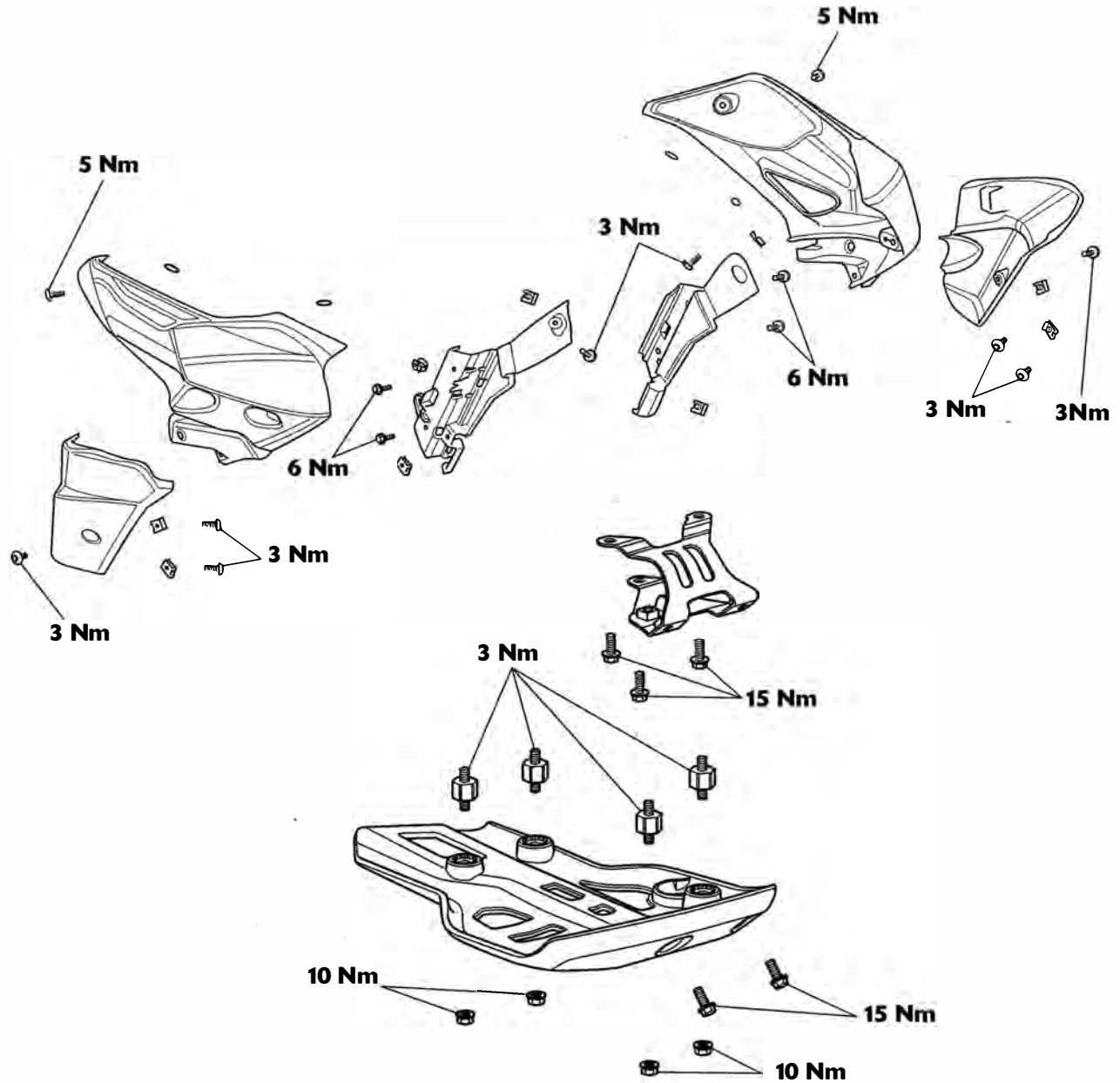

Exploded View - Rear Panels - all Models

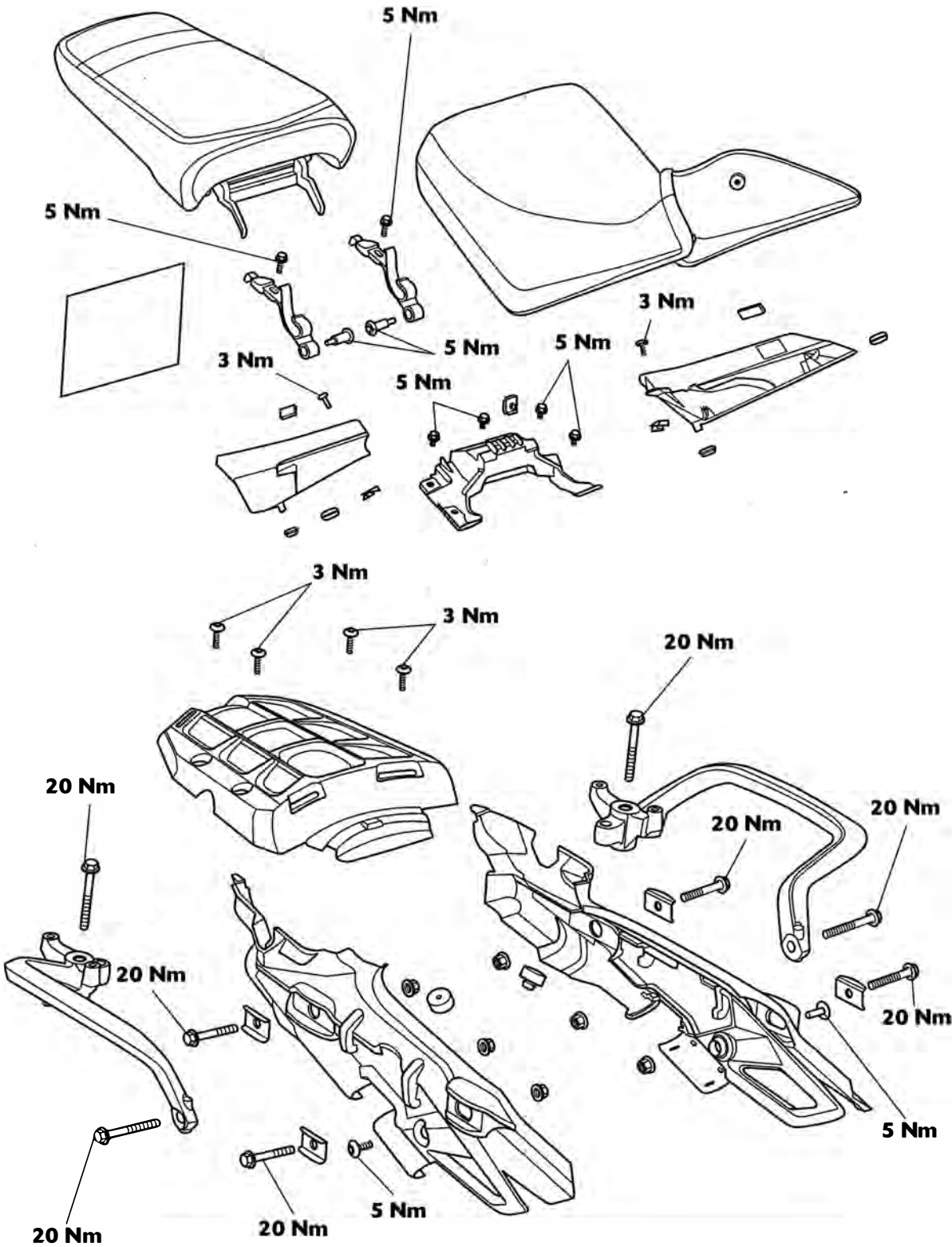

# Frame and Bodywork

## Exploded View - Footrests and Mountings - all Models

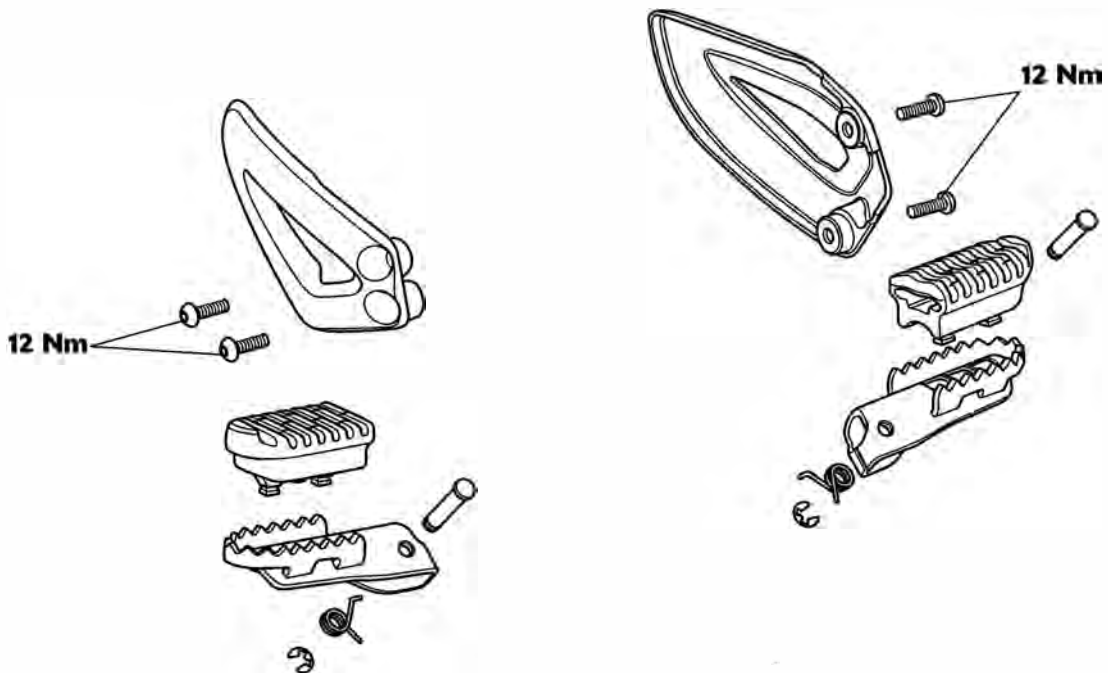
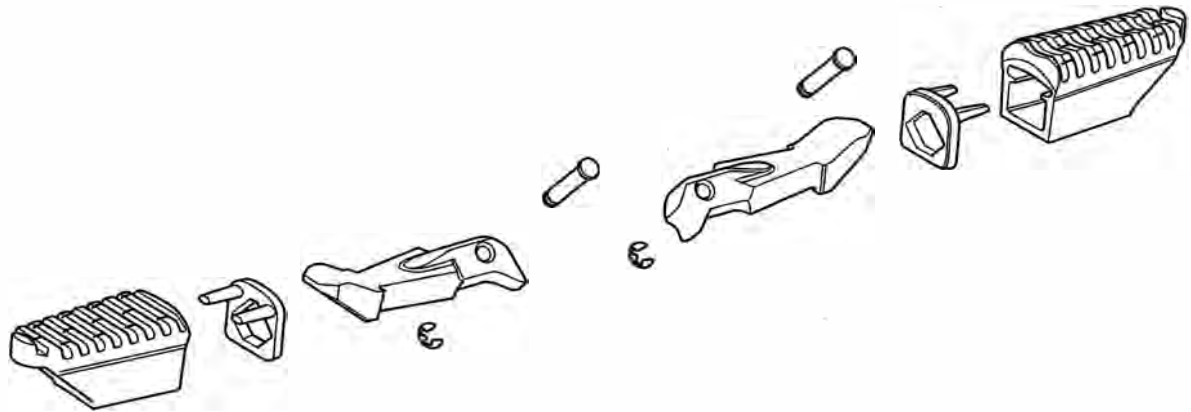

Exploded View - Sidestand - all Models

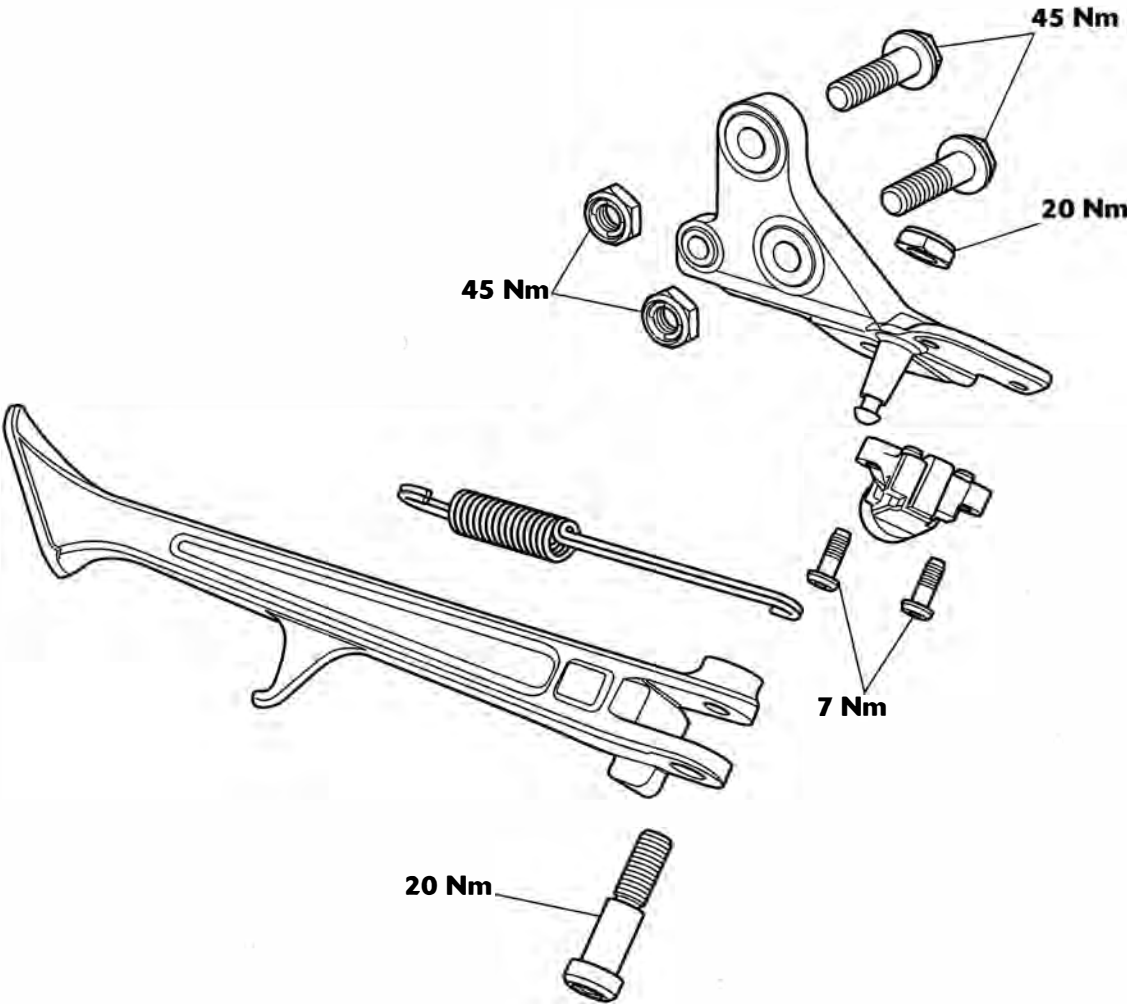

## Frame and Bodywork

---

### Exploded View - Front Mudguard - Tiger 800

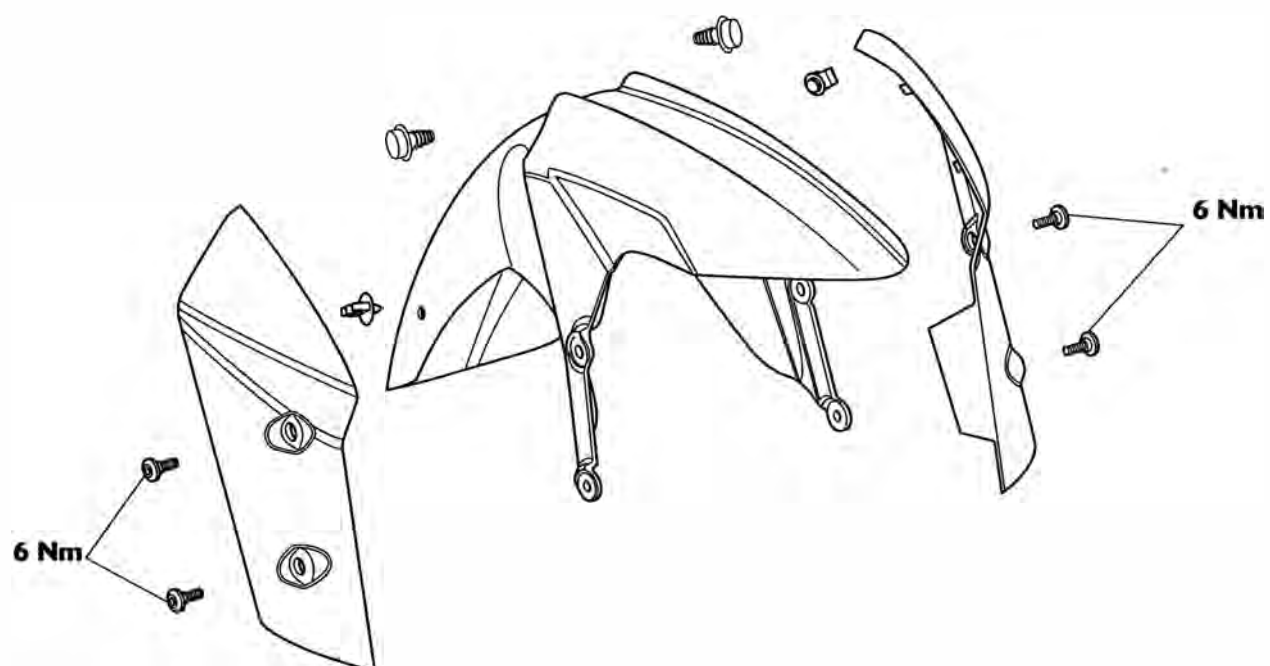

Exploded View - Front Mudguard - Tiger 800XC

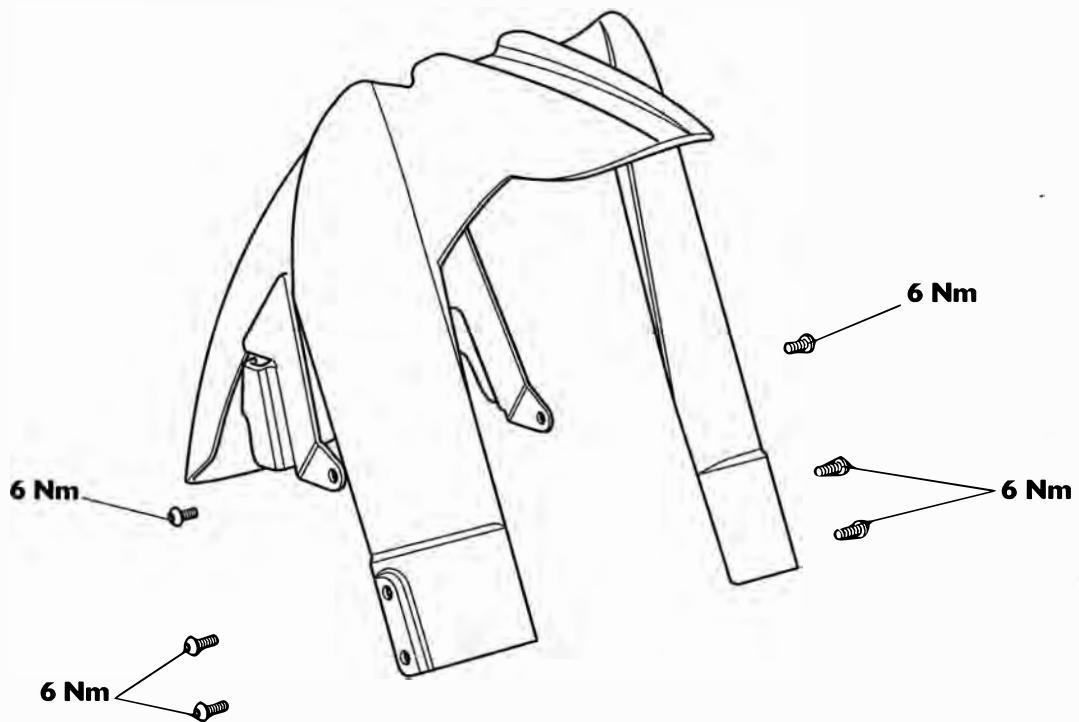

# Frame and Bodywork

## Exploded View - Rear Mudguard - all Models

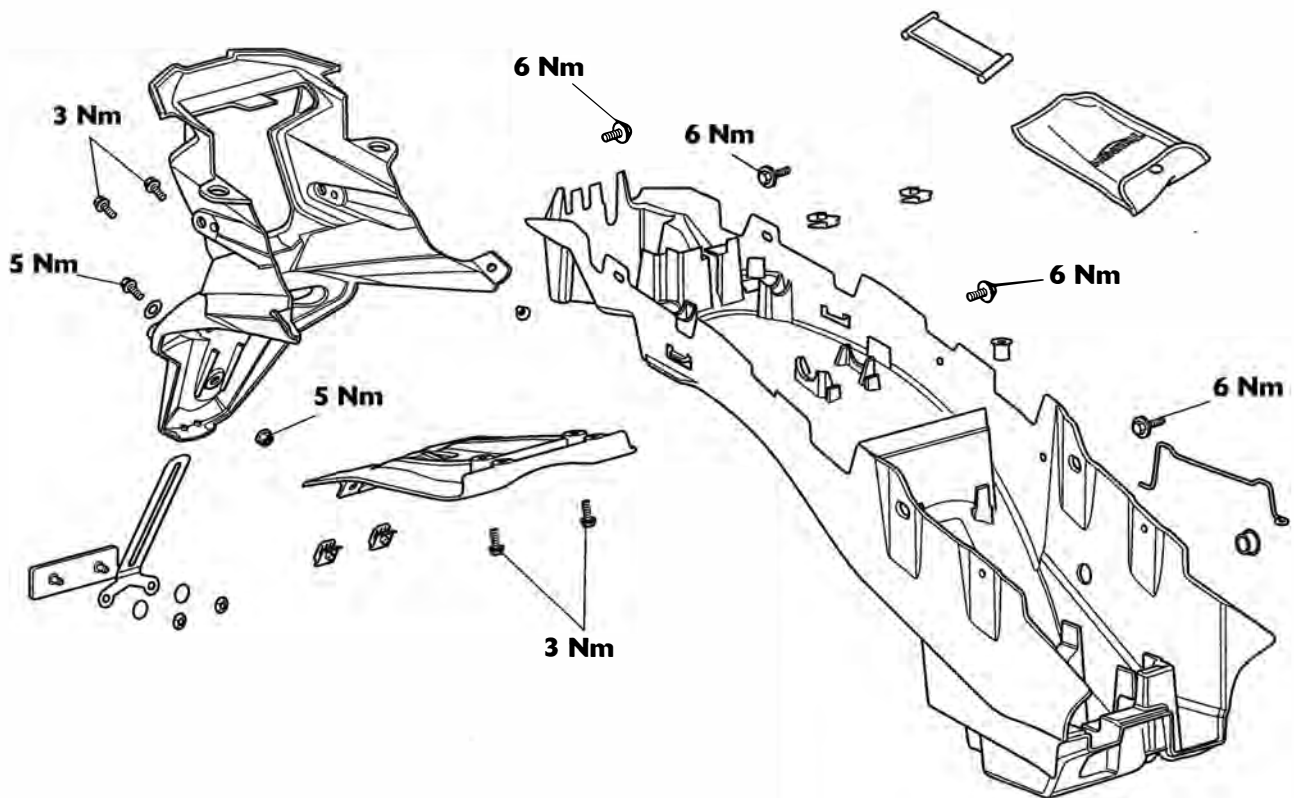



## Rear Seat

### Removal

The seat lock is located on the rear mudguard, below the rear light unit. To remove the seat, insert the ignition key into the seat lock and turn it anti-clockwise while pressing down on the rear of the seat. This will release the seat from its lock and allow it to be slid rearwards for complete removal from the motorcycle.

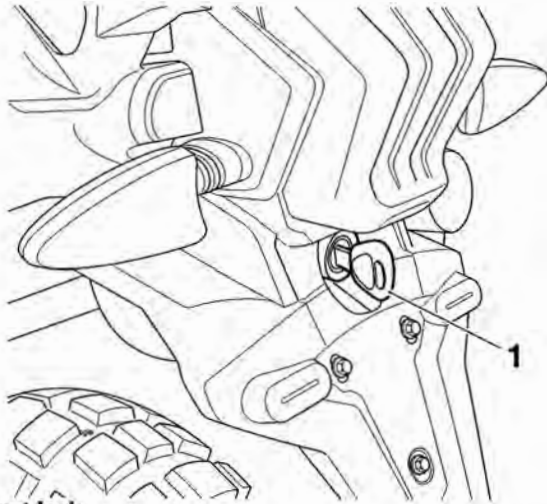

1. Seat lock

To refit the seat, engage the seat's two brackets under the loops on the subframe and press down at the rear to engage in the seat lock.

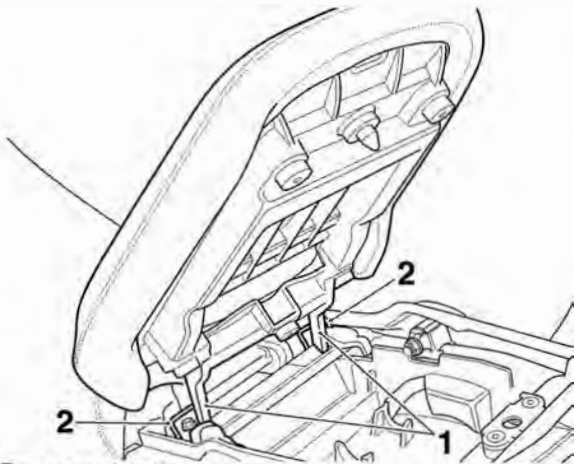

1. Rear seat brackets  
2. Subframe loops

### **Warning**

To prevent detachment of the seat during riding, after fitting always grasp the seat and pull firmly upwards. If the seat is not correctly secured, it will detach from the lock. A loose or detached seat could cause loss of motorcycle control and an accident.

## Rider's Seat

### Removal

To remove the rider's seat, remove the rear seat (see page 16-13).

Grasp the rider's seat on either side, and slide it rearwards and upwards for complete removal from the motorcycle.

To refit the seat, engage the seat's front rail into the bracket at the rear of the fuel tank and lower the rear rail into the rear brackets. Push down firmly on the rear of the seat.

Refit the rear seat (see page 16-13).

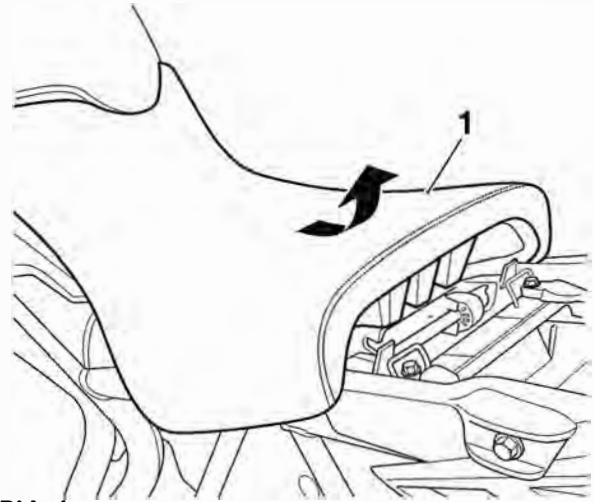

1. Rider's seat

To refit the seat, engage the seat's tongue under the fuel tank and press down at the rear to engage in the seat lock.

### **Warning**

To prevent detachment of the seat during riding, after fitting always grasp the seat and pull firmly upwards. If the seat is not correctly secured it will detach from the lock. A loose or detached seat could cause loss of motorcycle control and an accident.

### **Caution**

To prevent damage to the seat and its cover, care must be taken not to drop the seat. Do not lean the seat against the motorcycle or a wall as it may fall. Instead, place the seat, with the seat cover facing up, on a flat surface which is covered with a soft cloth.

# Frame and Bodywork

## Lower Radiator Panel

### Removal

1. Remove the two radiator infill fixings.

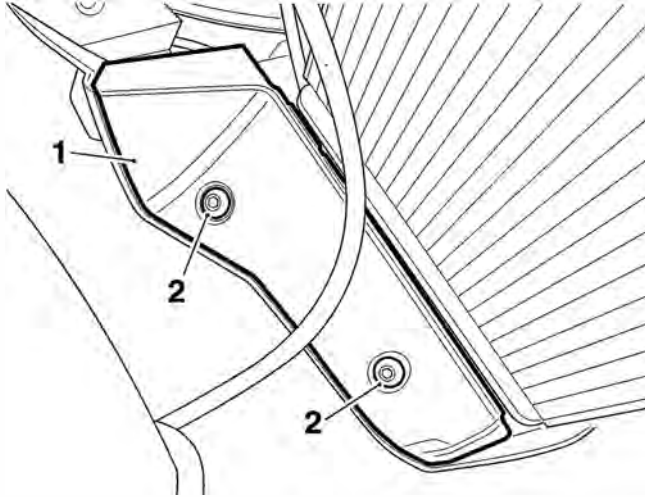

1. Radiator infill

2. Fixings

2. Remove the fixing and remove the panel towards the rear of the motorcycle.

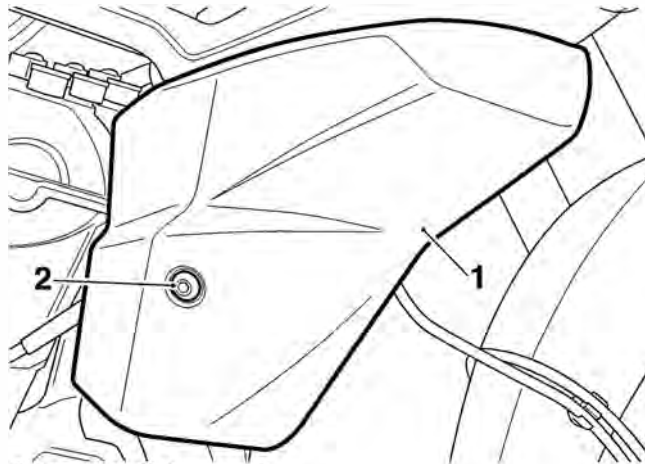

1. Lower radiator panel

2. Fixing

### Installation

1. Align the panel the hook on the upper radiator panel and secure with the three fixings.
2. Tighten the screws to **3 Nm**.

## Upper Radiator Panel

### Removal

1. Remove the rider's seat (see page 16-13).
2. Disconnect the battery, negative (black) lead first.
3. Remove the lower radiator panel (see page 16-14).
4. Remove and discard the radiator infill panel fixing.

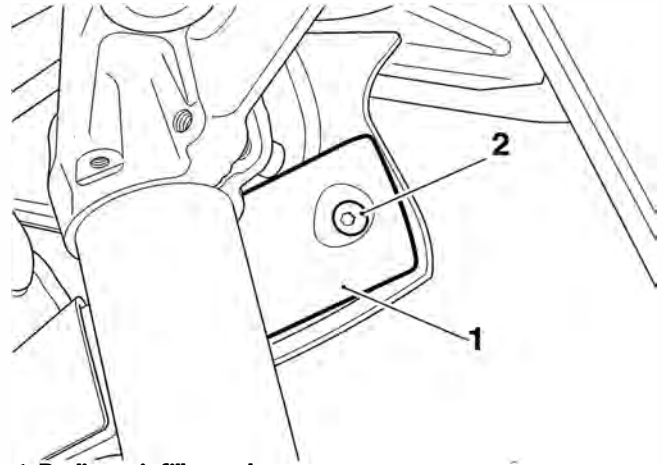

1. Radiator infill panel

2. Fixing

5. Remove the rear fixing and unhook the panel from the cockpit panel and fuel tank.

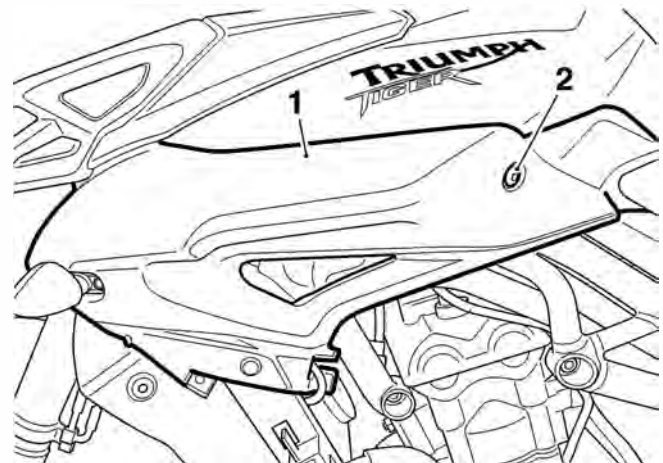

1. Upper radiator panel

2. Fixing

6. Disconnect the direction indicator connectors and remove the panel.

## Installation

1. Reconnect the direction indicator connectors.
2. Hook the front edge of the panel behind the cockpit panel and hook the tangs into the grommets on the fuel tank.
3. Refit the rear fixing and tighten to **5 Nm**.
4. Fit a new radiator infill panel fixing and tighten to **3 Nm**.
5. Refit the lower radiator panel (see page 16-14).
6. Reconnect the battery, positive (red) lead first.
7. Refit the rider's seat (see page 16-13).

## Radiator Infill Panel

### Removal

1. Remove the rider's seat (see page 16-13).
2. Disconnect the battery, negative (black) lead first.
3. Remove the lower radiator panel (see page 16-14).
4. Remove the upper radiator panel (see page 16-14).
5. **Right hand radiator infill panel only:** Remove the clip and detach the clutch cable and expansion tank vent hose.
6. If accessory fog lamps are fitted, remove the three cable ties and detach the fog lamp wiring. Detach the relay from the tang, and position aside.

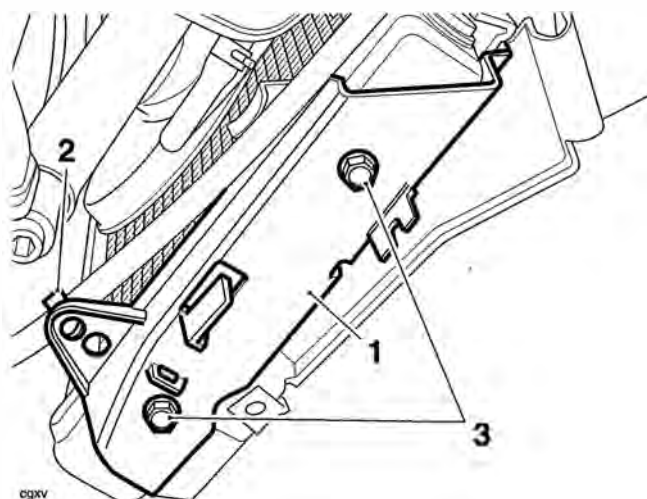

- cgxv
1. Radiator infill panel
  2. Clutch cable clip
  3. Fixings

7. **Left hand radiator infill panel only:** If accessory heated grips are fitted, remove the three cable ties and detach the heated grip wiring. Detach the relay from the tang, and position aside.

## Frame and Bodywork

- Remove the two fixings and remove the radiator infill panel.

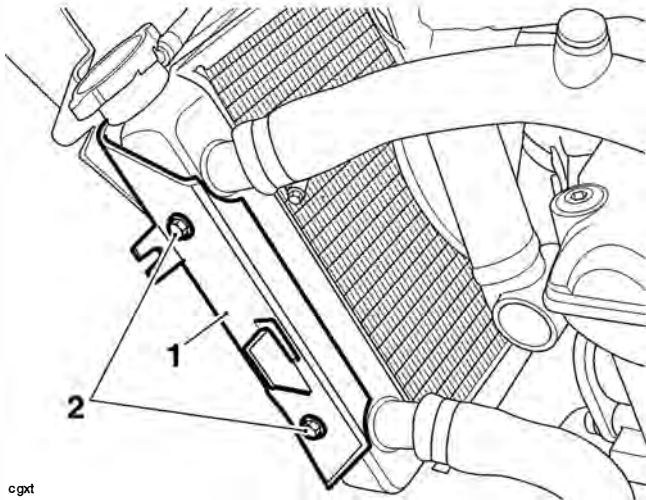

cgxt

- Radiator infill panel
- Fixings

- Tiger 800XC only:** Collect the radiator guard.

### Installation

- Tiger 800XC only:** Refit the radiator guard.
- Align the radiator infill panel to the radiator and secure with two new fixings. Tighten to **6 Nm**.
- Right hand radiator infill panel only:** Refit the clutch cable and expansion tank vent hose clip to the rear of the radiator infill panel.
- If accessory fog lamps are fitted, reposition the fog lamp wiring and secure with new cable ties. Attach the relay to the tang.
- Left hand radiator infill panel only:** If accessory heated grips are fitted, reposition the heated grip wiring and secure with new cable ties. Attach the relay to the tang.
- Refit the upper radiator panel (see page 16-14).
- Refit the lower radiator panel (see page 16-14).
- Reconnect the battery, positive (red) lead first.
- Refit the rider's seat (see page 16-13).

## Beak - Tiger 800XC only

### Removal

- Remove the four fixings and remove the beak in an upwards direction.



- Beak
- Fixings

### Installation

- Installation is the reverse of removal noting the following:

#### Note:

- Tighten the fixings to 3 Nm.**

## Cockpit Assembly

### Removal

#### Note:

- This procedure describes the removal and installation procedure for both Tiger 800 and Tiger 800XC models.

1. Remove the rider's seat (see page 16-13).
2. Disconnect the battery, negative (black) lead first.
3. Remove the two inner rear fixings, located near to the ignition switch.

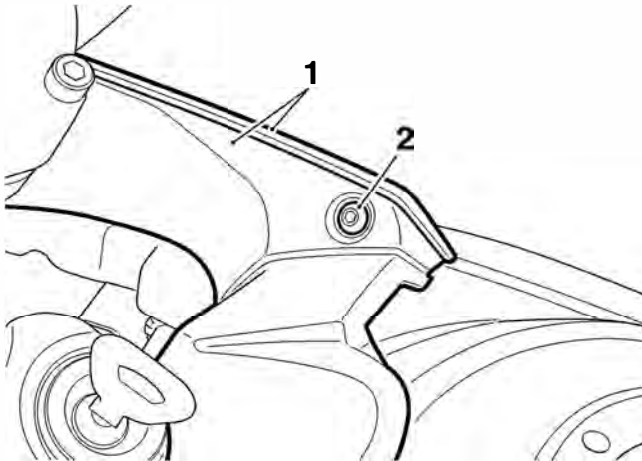

1. Cockpit panel
2. Rear fixing (right hand shown)

4. **Tiger 800XC only:** Remove and discard the two front lower fixings, located under the front mudguard.

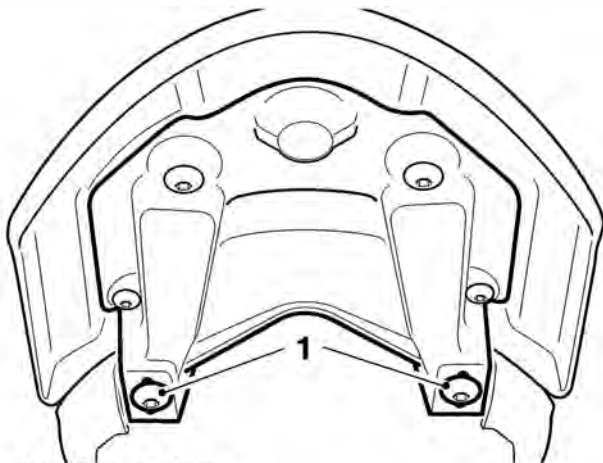

1. Front lower fixings

5. **All models:** Remove the front upper fixings, located below the headlight. Collect the nuts from the inside of the cockpit.

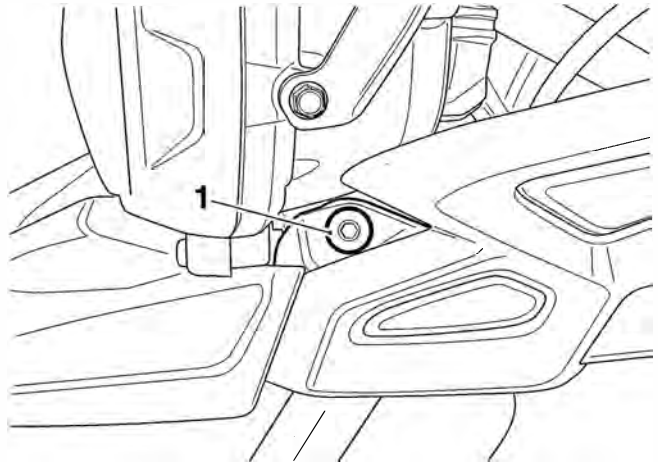

1. Front upper fixing (left hand shown)

6. Lift the rear of the cockpit assembly clear of the fuel tank, then carefully lower the front of the cockpit and remove towards the front of the motorcycle.

### Disassembly

#### Note:

- Removal and disassembly of the right hand cockpit side assembly is shown, removal of the left hand side is similar.

1. Remove the front fixing and separate the cockpit side assembly from the centre panel/beak support.

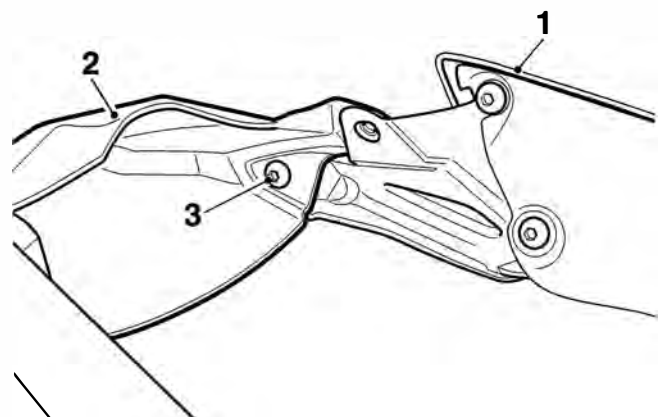

1. Cockpit side assembly
2. Centre panel/beak support (centre panel shown)
3. Fixing

## Frame and Bodywork

- Remove the three fixings and separate the cockpit infill and cockpit screen panels from the cockpit panel.

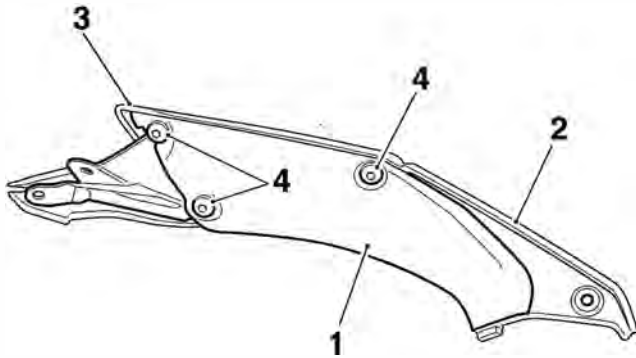

- Cockpit infill
- Cockpit panel
- Cockpit screen panels
- Fixings

### Assembly

- Align the cockpit infill and cockpit screen panels to the cockpit panel. Install the three fixings and tighten to **3 Nm**.
- Align the cockpit side assembly to the centre panel/beak support. Install the fixing and tighten to **3 Nm**.

### Installation

- Position the cockpit assembly to the motorcycle. Pass the cockpit side assemblies either side of the front forks and up over the front edge of the fuel tank.
- Position the rear of each cockpit side assembly to the fuel tank and clip the tabs on the panel into the lower edge of the ignition switch cover.
- Refit the two inner rear fixings and tighten to **5 Nm**.
- Tiger 800XC only:** Fit two new front lower fixings and tighten to **5 Nm**.
- All models:** Refit the front upper fixings, located below the headlight. Secure with the nuts and tighten to **5 Nm**.
- Reconnect the battery, positive (red) lead first.
- Refit the rider's seat (see page 16-13).

## Fuel Tank Infill Panel

### Removal

- Remove the rider's seat (see page 16-13).
- Remove the rear fixing, located to the rear of the airbox.

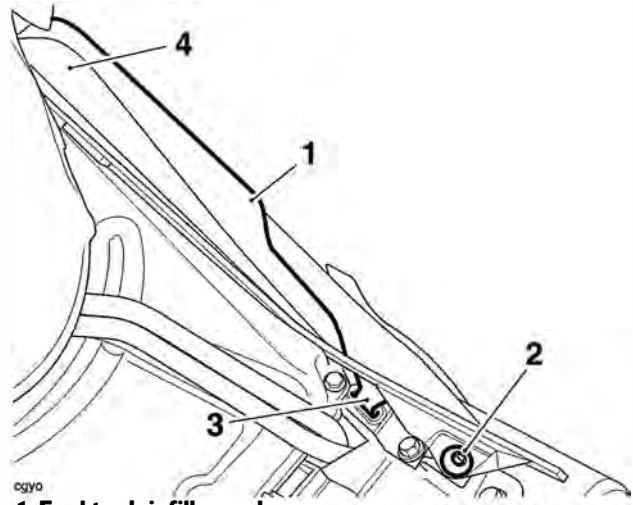

cgys

- Fuel tank infill panel
- Rear fixing (right hand shown)
- Rear tang
- Front tang location

- Lift the infill panel upwards, releasing the rear tang from the frame grommet.
- Slide the infill towards the rear of the motorcycle and release the front mounting tang from the frame grommet.

### Installation

- Installation is the reverse of removal noting the following:

#### Note:

- Tighten the fixing to **3 Nm**.

## Windscreen

### Removal

1. Release the two upper mounting fixings, collecting the nuts from the inside of the mounting as you do so.
2. Remove the two side fixings and remove the windscreen.

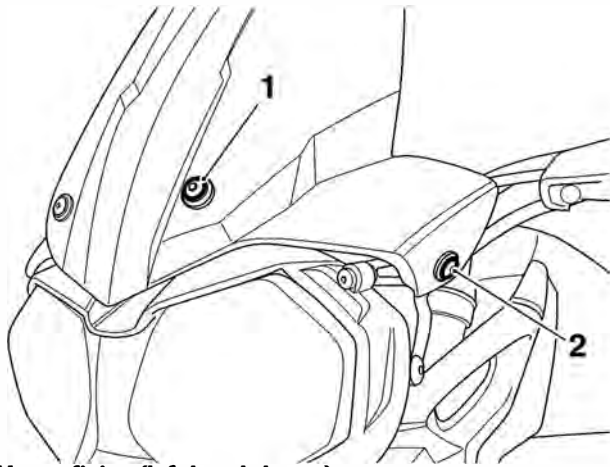

1. Upper fixing (left hand shown)
2. Side fixing (left hand shown)

### Installation

3. Fit the windscreen to the upper mounting, and secure with the bolts and nuts. Tighten to **3 Nm**.
4. Align the windscreen to the side fixings, and secure with the bolts and nuts. Tighten to **3 Nm**.

## Front Mudguard - Tiger 800

### Removal

1. Detach the front brake hose from the two clips on the front mudguard.
2. Remove the two right hand fixings and collect the front fork protector.

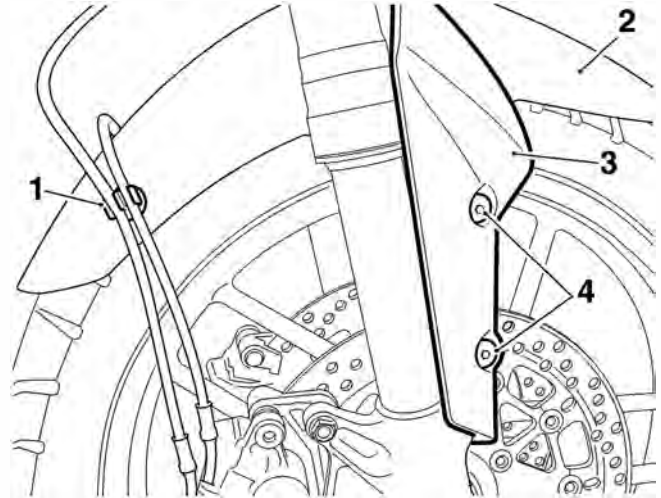

1. Brake hose clip
2. Front fork protector
3. Mudguard
4. Fixings

3. Support the front mudguard and remove the two left hand fixings, collecting the front fork protector as the bolts are removed. Carefully remove the mudguard towards the front of the motorcycle.

### Installation

1. Position the front mudguard to the front forks.
2. Reposition the right hand front fork protector to the mudguard, align the holes and refit the two fixings. Do not tighten at this stage.
3. Reposition the left hand front fork protector to the mudguard, align the holes and refit the two screws. Tighten the four fixings to **6 Nm**.
4. Refit the front brake hose to the mudguard clips.

# Frame and Bodywork

## Front Mudguard - Tiger 800XC

### Removal

1. Detach the front brake hose from the two clips on the front mudguard.
2. Remove and discard the two rear fixings.
3. Support the front mudguard and remove the four lower fixings. Discard the fixings.
4. Remove the mudguard towards the front of the motorcycle.

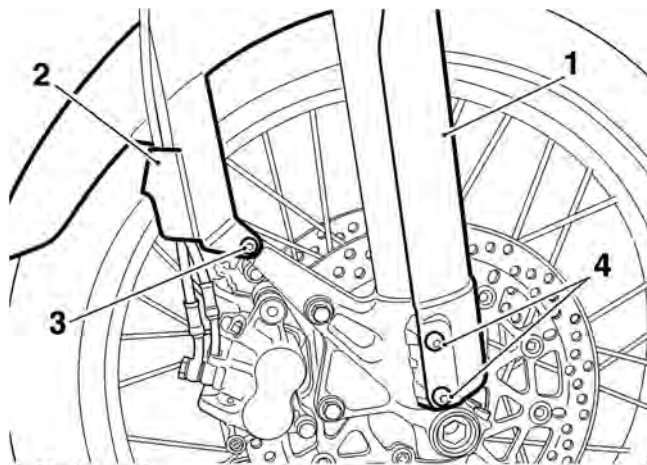

1. Mudguard
2. Brake hose clip
3. Rear fixing
4. Lower fixings

### Installation

1. Position the front mudguard to the front forks.
2. Fit four new lower fixings and tighten to **6 Nm**.
3. Fit two new rear fixings and tighten to **6 Nm**.
4. Refit the front brake hose to the mudguard clips.

## Rear Rack

### Removal

1. Remove the rear seat (see page 16-13).
2. Remove the four fixings and remove the rack.

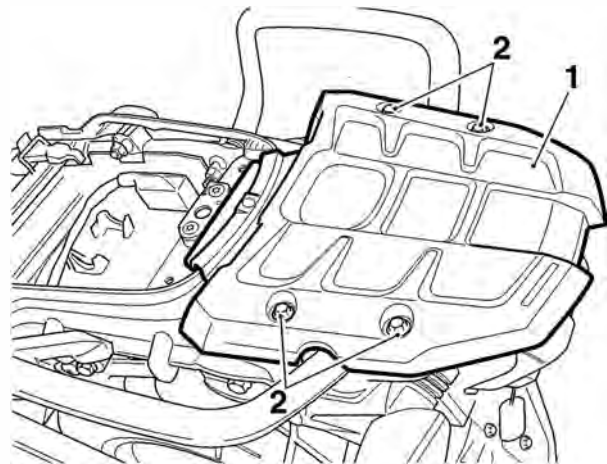

1. Rear rack
2. Fixings

### Installation

1. Position the rear rack to the motorcycle.
2. Refit the four fixings and tighten to **3 Nm**.
3. Refit the rear seat (see page 16-13).



## Rear Side Panel

### Removal

1. Remove the rider's seat (see page 16-13).
2. Disconnect the battery, negative (black) lead first.
3. Remove the rear rack (see page 16-20).
4. Remove the rear grab handle bolt.
5. Remove the front nut and bolt and remove the grab handle.

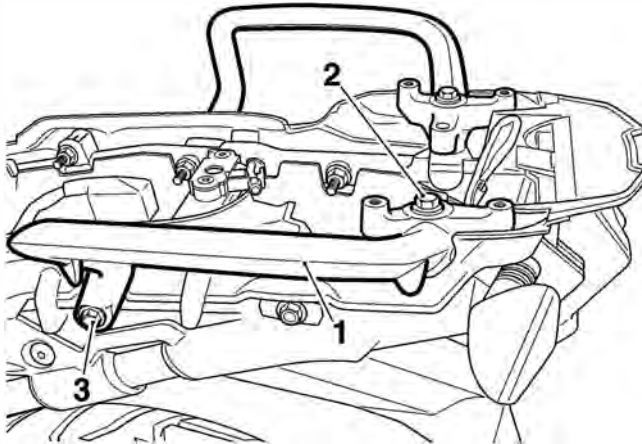

1. Rear grab handle
2. Rear bolt
3. Front bolt/nut (nut not shown)

6. Remove the side panel bolts and nuts. Collect the pannier mount plates from the bolts.
7. Remove the side panel lower fixing and remove the side panel.

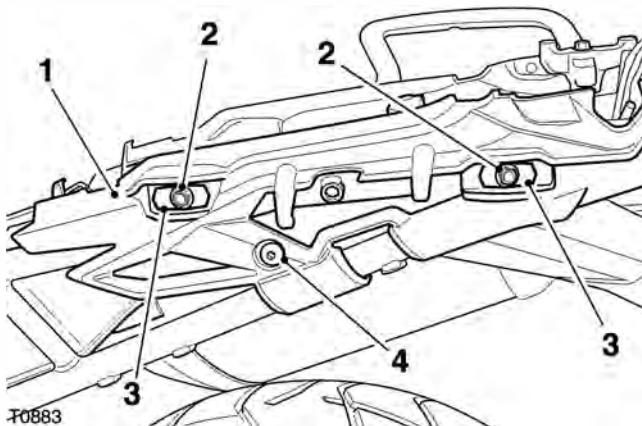

- 70883
1. Side panel (left hand shown)
  2. Bolts/nuts (nuts not shown)
  3. Pannier mount plates
  4. Lower fixing

### Installation

1. Refit the side panel and secure with the lower fixing. Do not tighten the fixing at this stage.
2. Refit the pannier mounting plates to the bolts and refit the bolts. Refit the nuts and tighten to **20 Nm**.
3. Tighten the lower fixing to **5 Nm**.
4. Refit the grab handle and secure the front with the bolt and nut and rear with the bolt. Tighten both fixings to **20 Nm**.
5. Refit the rear rack (see page 16-21).
6. Reconnect the battery, positive (red) lead first.
7. Refit the rider's seat (see page 16-13).

# Frame and Bodywork

## Rear Mudguard

### Removal

1. Remove the rider's seat (see page 16-13).
2. Disconnect the battery, negative (black) lead first.
3. Remove the rear rack (see page 16-20).
4. Remove the rear side panels (see page 16-21).

### Note:

- **The reflector bracket is secured by a nut and bolt located behind the licence plate in all markets where a mudguard extension is not required by law.**
- **The rear mudguard extension is installed instead of the splash guard in certain markets as standard, or is available as an accessory from your Triumph dealer. The mudguard extension uses the same fixings as the splash guard shown below, with the addition of a third fixing behind the licence plate.**

1. Remove the two lower splash guard or mudguard extension fixings located under the rear mudguard.

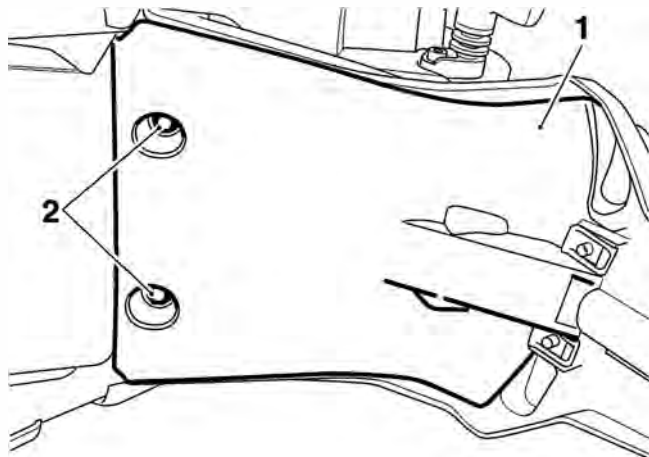

1. **Splash guard (mudguard extension is similar)**
2. **Fixings**
3. **All models:** Remove the two upper fixings located behind the licence plate.

4. Remove the splash guard or mudguard extension.

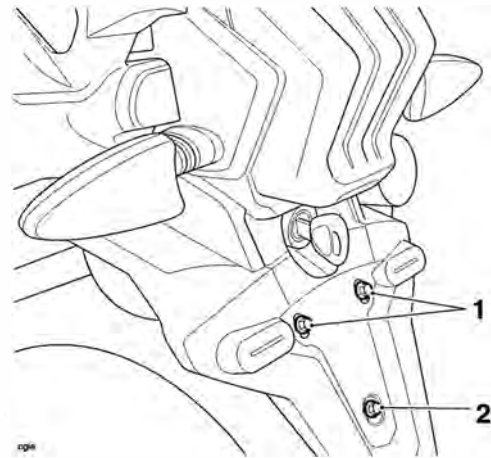

1. **Fixings**
2. **Mudguard extension or reflector bracket fixing (only if fitted)**
5. Noting the cable routing, disconnect the rear direction indicator connectors.
6. Remove the two seat rail fir-tree clips.

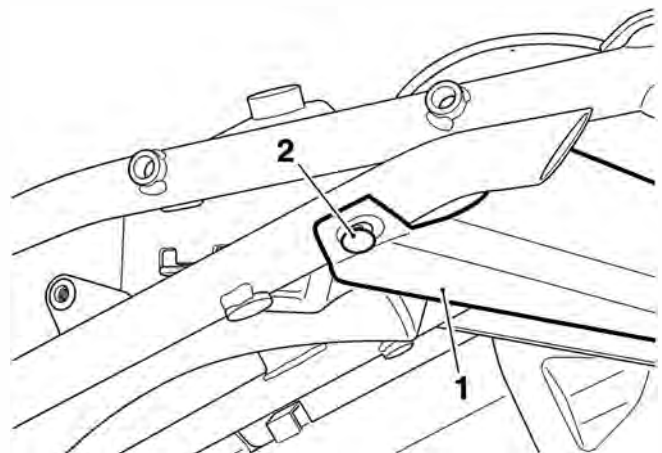

1. **Rear mudguard**
2. **Fir-tree clip**

7. Lift the rear mudguard off the two rear seat rail lugs, along with the rear light and seat lock assembly.

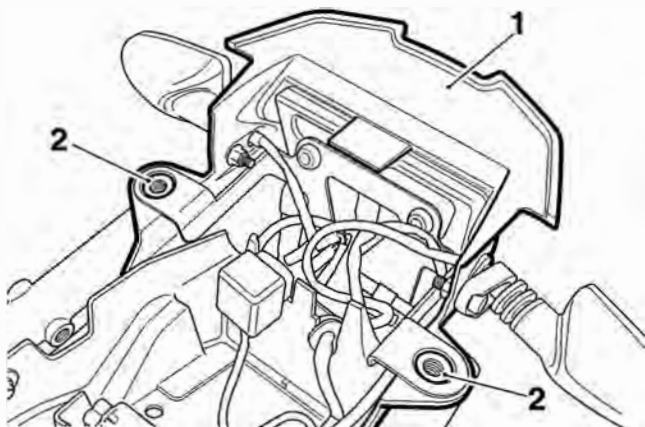

**1. Rear mudguard**

**2. Seat rail lugs**

8. Carefully separate the rear mudguard from the rear light and seat lock assembly and remove from the motorcycle.  
Do not allow the rear light and seat lock assembly to hang from the rear light harness or seat lock cable.

### Installation

1. Align the rear mudguard to the rear light and seat lock assembly.
2. Position the rear mudguard to the seat rails, and locate the holes in the mudguard over the lugs on the frame.
3. Secure the rear mudguard to the seat rails using new fir-tree clips.
4. Following the routing noted during disassembly, reconnect the rear direction indicators.
5. Refit the splash guard or mudguard extension. Secure the splash guard or mudguard extension with the four screws and tighten to **3 Nm**.
6. Install the lower mudguard extension or reflector bracket fixing and tighten to **5 Nm**.
7. **All models:** Refit the rear side panels (see page 16-21).
8. Refit the rear rack (see page 16-21).
9. Reconnect the battery, positive (red) lead first.
10. Refit the rider's seat (see page 16-13).

# Frame and Bodywork

## Sump Guard

### Removal

1. Remove and discard the two front fixings.
2. Remove and discard the four nuts and remove the sump guard.

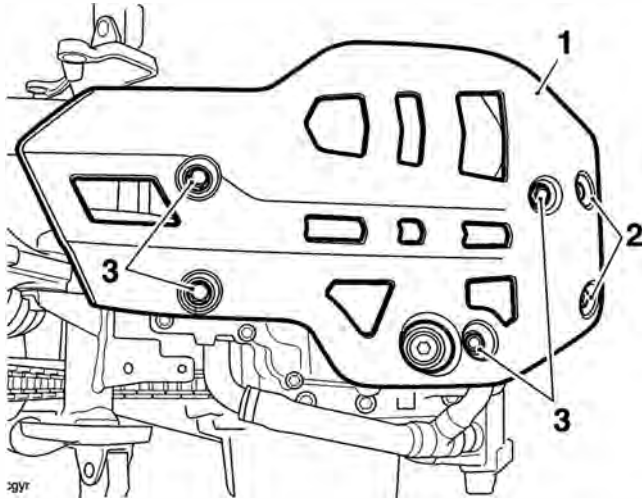

1. Sump guard  
2. Front fixings  
3. Rear fixing nuts

### Installation

1. Align the sump guard to the motorcycle and secure with four new nuts. Do not fully tighten at this stage.
2. Fit two new front fixings.
3. Tighten the front bolts to **15 Nm**.
4. Tighten the nuts to **10 Nm**.

## Frame, Footrests and Fixings

### Inspection

1. Inspect the frame, footrests and bodywork for damage, cracks, chafing and other dangerous conditions. Check bodywork and frame fixings for security.



### Warning

If the motorcycle is involved in an accident or collision it must be taken to an authorised Triumph dealer for repair or inspection.

Any accident can cause damage to the motorcycle which, if not correctly repaired, may cause another accident which may result in injury or death.



### Warning

The frame must not be modified as any modification to the frame such as welding or drilling may weaken the frame resulting in an accident.

# 17 Electrical

## Table of Contents

Exploded View - Instruments . . . . .	17.3
Exploded View - Headlight . . . . .	17.4
Exploded View - Rear Light & Reflectors . . . . .	17.5
Exploded View - Direction Indicators . . . . .	17.6
Exploded View - Alternator, Starter and Immobiliser . . . . .	17.7
Battery . . . . .	17.8
Battery Removal . . . . .	17.8
Battery Refit . . . . .	17.8
Battery Commissioning and Charging . . . . .	17.9
New Battery . . . . .	17.9
Battery Maintenance . . . . .	17.10
Battery Already in Service . . . . .	17.10
Table of Battery Charging Times . . . . .	17.10
Relays . . . . .	17.11
Relay Identification . . . . .	17.11
Direction Indicator Unit . . . . .	17.11
Fuses . . . . .	17.11
Fuse Identification . . . . .	17.11
Front fuse box . . . . .	17.12
Rear fuse box . . . . .	17.12
Instrument Pack . . . . .	17.13
Removal . . . . .	17.13
Installation . . . . .	17.13
Headlights . . . . .	17.14
Headlight Adjustment . . . . .	17.14
Headlight Bulb Replacement . . . . .	17.14
Installation . . . . .	17.14
Position Lamp Bulb Replacement . . . . .	17.15
Installation . . . . .	17.15
Headlight Assembly . . . . .	17.15
Removal . . . . .	17.15
Installation . . . . .	17.15
Rear Light . . . . .	17.16

Removal .....	17.16
Installation .....	17.16
Direction Indicators .....	17.16
Bulb Replacement .....	17.16
Rear Direction Indicator .....	17.17
Removal .....	17.17
Installation .....	17.17
Front Direction Indicator .....	17.17
Removal .....	17.17
Installation .....	17.17
Starter Motor .....	17.18
Removal .....	17.18
Inspection .....	17.18
Installation .....	17.18
Alternator .....	17.19
Removal .....	17.19
Assembly .....	17.20
Alternator Rectifier .....	17.21
Alternator Stator .....	17.22
Pinpoint Tests .....	17.22
Rectifier/Regulator .....	17.24
Pinpoint Tests .....	17.24
Lighting Circuit .....	17.26
Key to circuit diagram .....	17.26
Key to wiring colours .....	17.26
Starting and Charging Circuit .....	17.28
Key to circuit diagram .....	17.28
Key to wiring colours .....	17.28
Auxiliary and Accessory Circuit .....	17.30
Key to circuit diagram .....	17.30
Key to wiring colours .....	17.30
Engine Management Circuit Diagram - Tiger 800 and Tiger 800XC .....	17.32
Key To Wiring Circuit Diagram .....	17.32
Key To Wiring Colour Codes .....	17.32
Engine Management Circuit Diagram - Tiger 800 (ABS) and Tiger 800XC (ABS) .....	17.34
Key To Wiring Circuit Diagram .....	17.34
Key To Wiring Colour Codes .....	17.34
Complete System - Tiger 800 and Tiger 800XC - without ABS .....	17.36
Key to circuit diagram .....	17.36
Complete System - Tiger 800 and Tiger 800XC - with ABS .....	17.38
Key to circuit diagram .....	17.38

Exploded View - Instruments

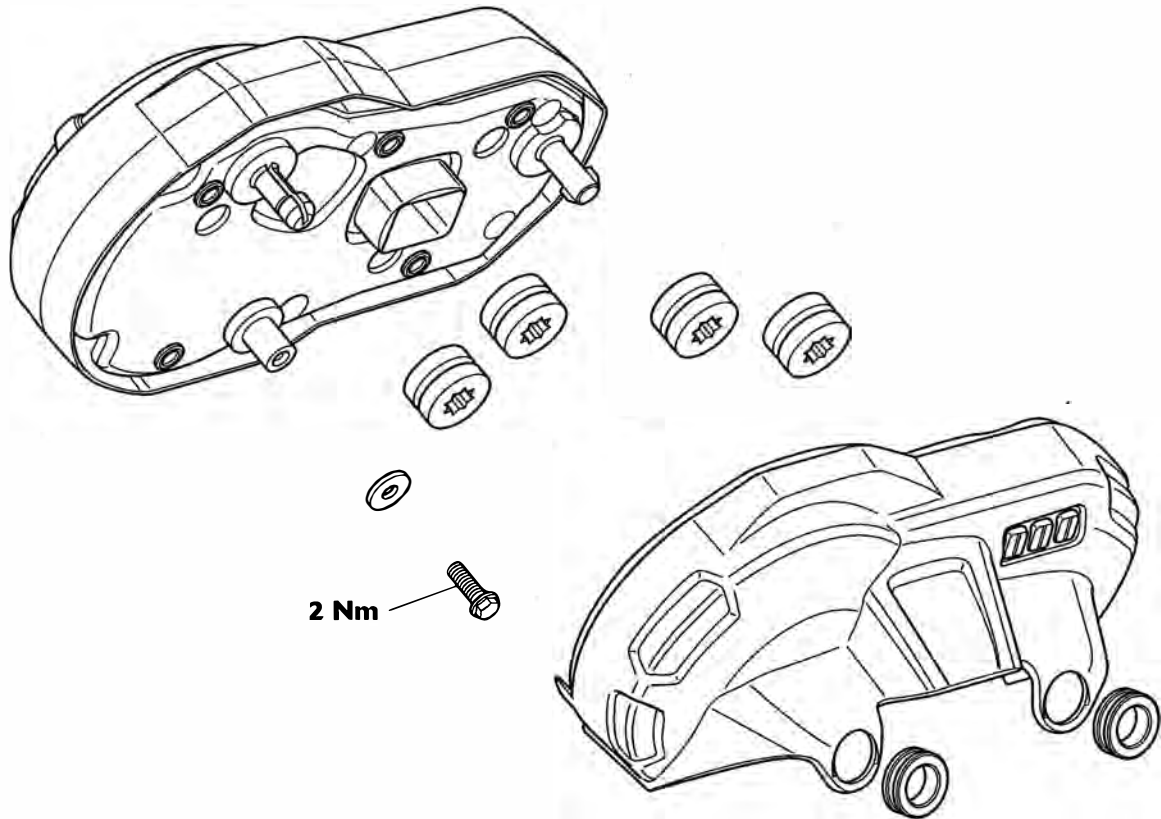

## Exploded View - Headlight

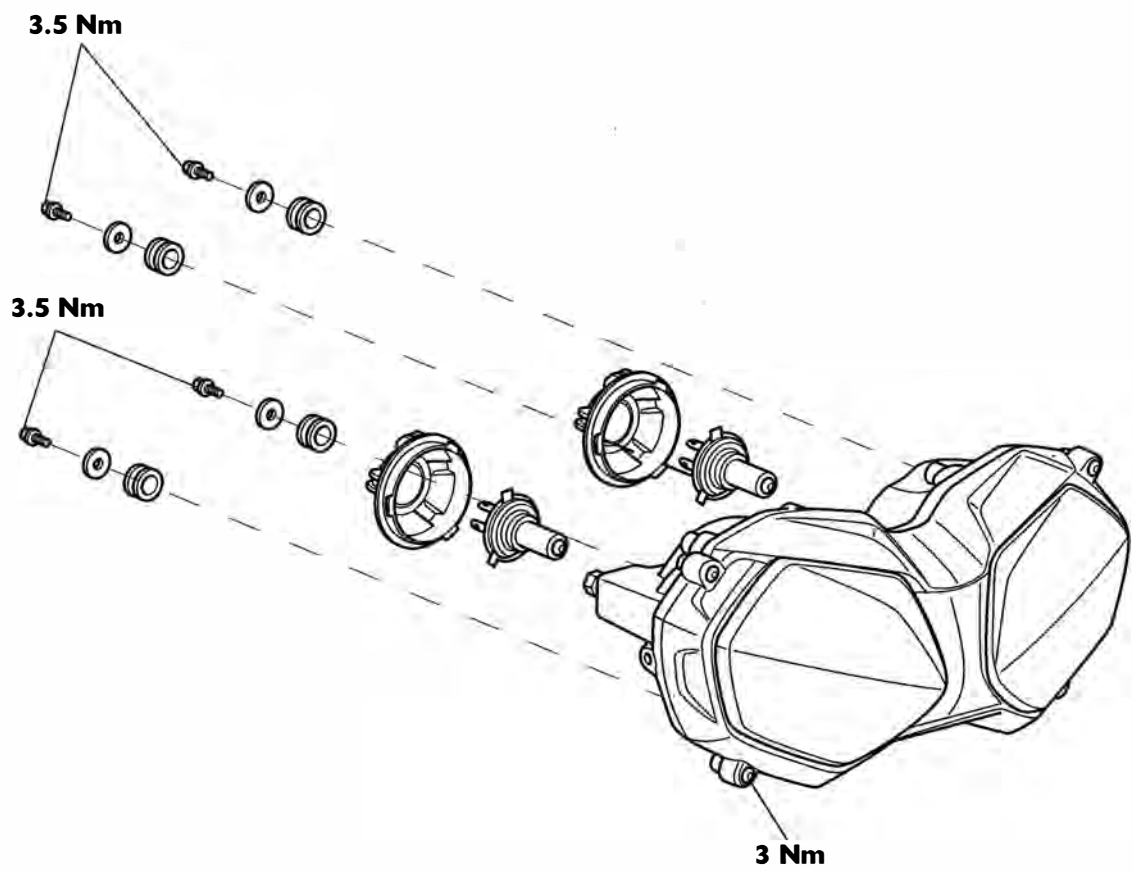



Exploded View - Rear Light & Reflectors

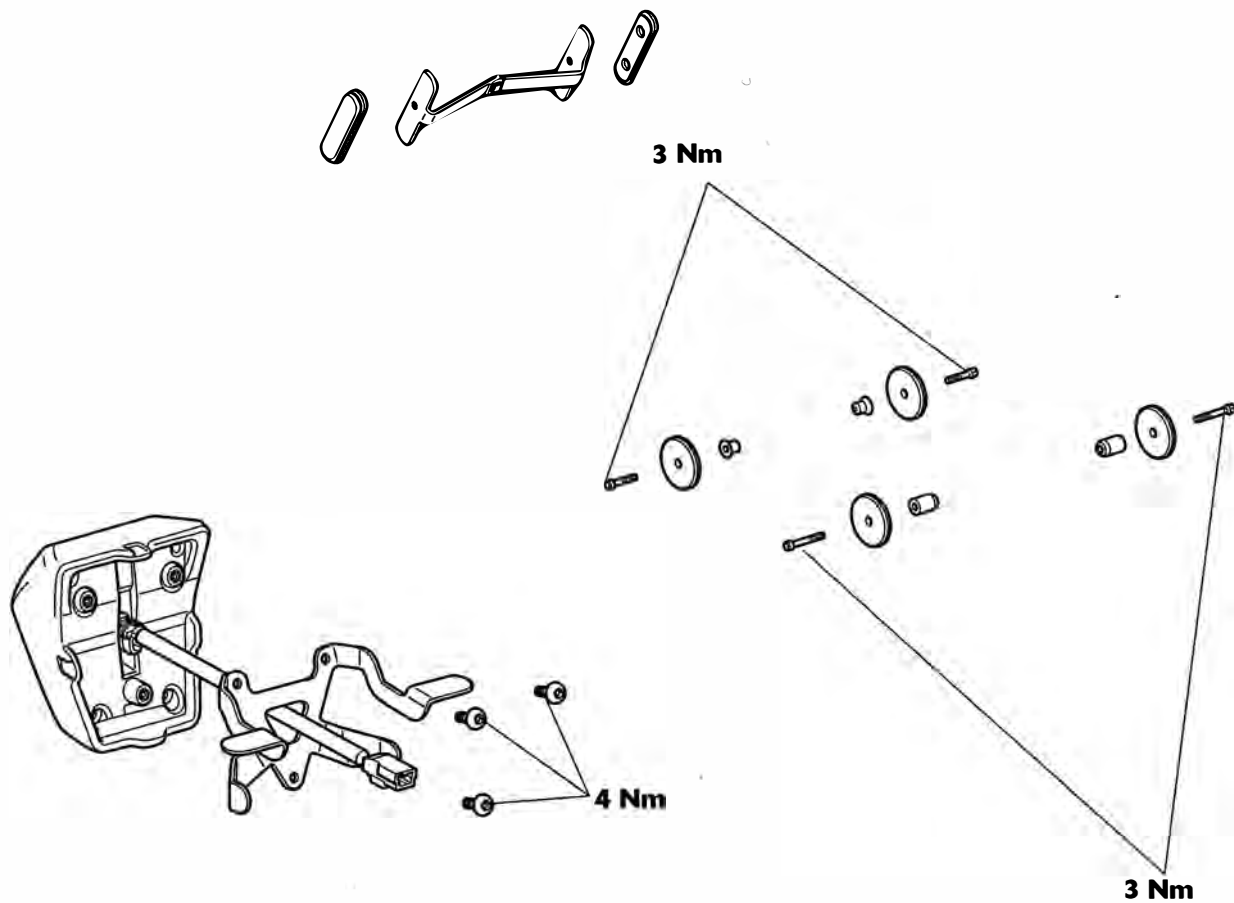

# Electrical

## Exploded View - Direction Indicators

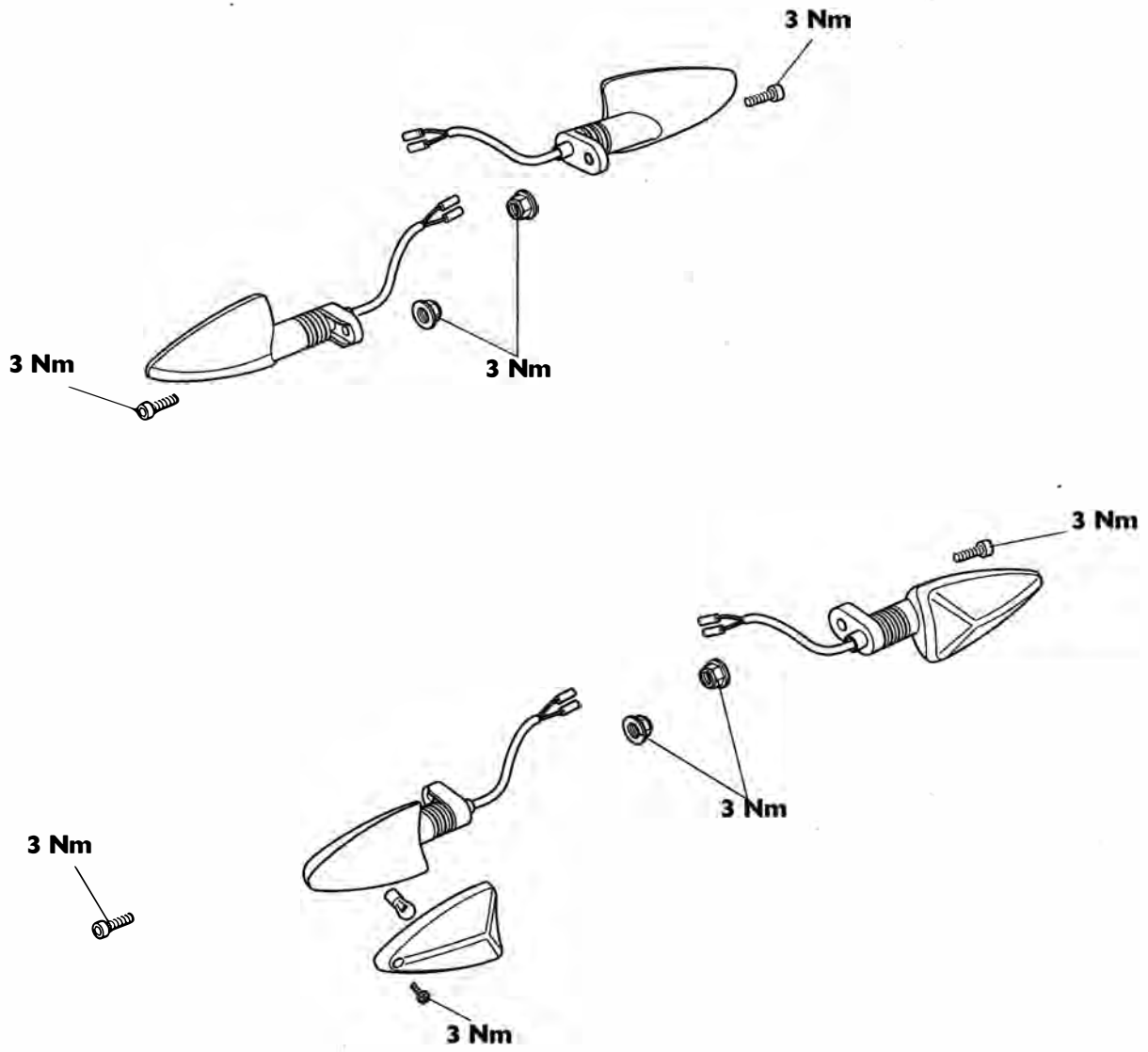

Exploded View - Alternator, Starter and Immobiliser

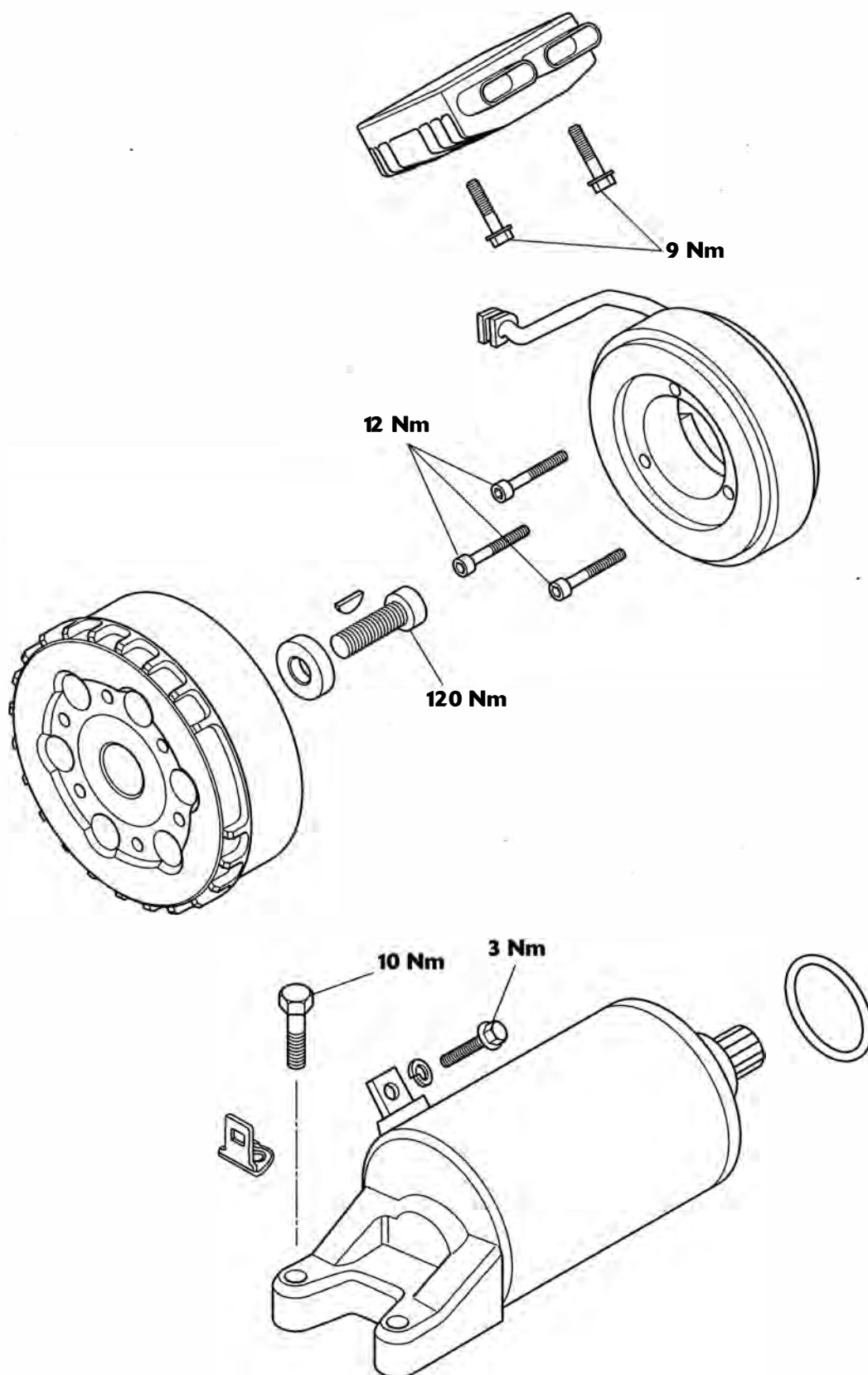

## Battery

### Warning

The battery gives off explosive gases; keep sparks, flames and cigarettes away. Provide adequate ventilation when charging or using the battery in an enclosed space.

The battery contains sulphuric acid (electrolyte). Contact with skin or eyes may cause severe burns. Wear protective clothing and a face shield.

- If electrolyte gets on your skin, flush with water immediately.
- If electrolyte gets in your eyes, flush with water for at least 15 minutes and SEEK MEDICAL ATTENTION IMMEDIATELY.
- If electrolyte is swallowed, drink large quantities of water and SEEK MEDICAL ATTENTION IMMEDIATELY.

KEEP ELECTROLYTE OUT OF THE REACH OF CHILDREN.

### Warning

The battery contains harmful materials. Always keep children away from the battery whether or not it is fitted in the motorcycle.

Do not jump start the battery, touch the battery cables together or reverse the polarity of the cables as any of these actions may cause a spark which would ignite battery gasses causing a risk of personal injury.

### Warning

The battery electrolyte is corrosive and poisonous. Never swallow battery electrolyte or allow electrolyte to come into contact with the skin. Always wear eye and skin protection when adjusting the electrolyte level.

## Battery Removal

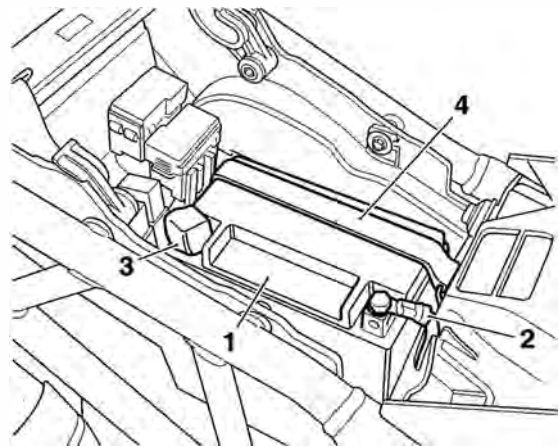

1. Battery
2. Negative (-) terminal
3. Positive (+) terminal
4. Battery strap

1. Remove the rider's seat (see page 16-13).
2. Disconnect the battery, negative (black) lead first.
3. Remove the battery strap.
4. Take the battery out of the case.

### Warning

Ensure that the battery terminals do not touch the motorcycle frame as this may cause a short circuit or spark which would ignite battery gases causing a risk of personal injury.

## Battery Refit

### Warning

Ensure that the battery terminals do not touch the motorcycle frame as this may cause a short circuit or spark which would ignite battery gases causing a risk of personal injury.

1. Place the battery in the battery case.
2. Reconnect the battery, positive (red) lead first.
3. Apply a light coat of grease to the terminals to prevent corrosion.
4. Cover the terminals with the protective caps.
5. Refit the battery strap.
6. Refit the rider's seat (see page 16-13).

## Battery Commissioning and Charging

### New Battery

In order to correctly and safely commission a new battery, the battery commissioning procedure listed below must be carefully followed. This is the only battery commissioning procedure that Triumph recommends. The procedure is designed to ensure that the battery is at its best when fitted to the motorcycle, and will provide the best possible performance and reliability.

Failure to comply with this procedure may lead to reduced battery performance and/or shorten the life of the battery.

#### **Warning**

The battery gives off explosive gases; keep sparks, flames and cigarettes away. Provide adequate ventilation when charging or using the battery in an enclosed space.

The battery contains sulphuric acid (electrolyte). Contact with skin or eyes may cause severe burns. Wear protective clothing and a face shield.

- If electrolyte gets on your skin, flush with water immediately.
- If electrolyte gets in your eyes, flush with water for at least 15 minutes and **SEEK MEDICAL ATTENTION IMMEDIATELY.**
- If electrolyte is swallowed, drink large quantities of water and **SEEK MEDICAL ATTENTION IMMEDIATELY.**

KEEP ELECTROLYTE OUT OF THE REACH OF CHILDREN.

1. Ensure the VIN number printed on the anti-tamper label attached to the battery matches the motorcycle VIN.
2. Read the instructions and warnings delivered with the battery.
3. Place the battery on a flat level surface and remove the sealing foil.

#### **Caution**

Ensure the electrolyte container part number matches the battery part number to be filled. Battery life will be greatly reduced if the incorrect volume (either too little or too much) of acid is added to the battery.

4. Remove the battery sealing strip from the electrolyte container (if applicable) and save for later in this procedure. Place the sealing strip on a clean surface,

with the upper side facing downwards to avoid contamination of the sealing strip. Do not break the seal on the electrolyte container.

5. Place the electrolyte container and adapter (if applicable) on the battery and fill the battery according to the manufacturers instructions.
6. After starting to fill the battery with electrolyte, allow the battery to stand for 30 minutes with the filling container in place.
7. Check that all of the electrolyte has drained from the container. Do not remove the container at this point. If the container has not completely drained, tap the sides of the container to start the electrolyte flowing again.
8. After the electrolyte has drained into the battery, allow the battery to stand with the electrolyte container in place for a further 30 minutes for batteries 3Ah - 12Ah or 1 hour for batteries greater than 12Ah.
9. Remove the electrolyte container and adapter carefully, and dispose of immediately.
10. Place the sealing cap strip LOOSELY over the filling holes of the battery.
11. Charge the battery using the BatteryMate 150-9. Refer to the instructions supplied with the BatteryMate 150-9.

#### **Caution**

The caps must be fitted (after charging) within two hours of filling the battery with acid. Leaving the battery open to the atmosphere for longer than is necessary will start to reverse the chemical reaction which takes place within the battery, greatly reducing the battery life.

12. After charging is complete, press down firmly with both hands to seat the caps (do not use tools or force the caps into position).
13. Disconnect the charger and allow the battery to stand for 1 hour before fitting to the motorcycle.
14. Fit the battery to the motorcycle, positive (red) lead first.

# Electrical

## Battery Maintenance

The battery is a sealed type and does not require any maintenance other than routine recharging such as during storage.

It is not possible to adjust the electrolyte level in the battery.

### Note:

- **The charge level in the battery must be maintained to maximise the battery life.**

With normal use of the motorcycle, the charging system will keep the battery charged. If the motorcycle is unused the battery will gradually discharge due to battery self discharge and the continuous current drain for the clock and the engine control module memory.

The rate of battery discharge can be greatly increased by the addition of electrical security systems or other accessories.

If the motorcycle is used for very short journeys, the alternator will not have enough time to replenish the charge used to start and run it. Therefore, the battery should be charged after each return journey following the instructions and advice given here and in the owner handbook under the sections Battery Discharge and Battery Discharge During Storage and Infrequent Use of the Motorcycle.

Allowing a battery to discharge, or leaving it discharged over a period of time, causes sulphation of the lead plates

within the battery.

Sulphation is a normal chemical reaction inside the battery and over a period of time sulphate will crystallise on to the lead plates making charging difficult or impossible. The result is a permanently damaged battery, which would not be covered by the motorcycle warranty.

Keeping a battery at full charge reduces the chance of it freezing in cold conditions. Allowing a battery to freeze can cause serious internal damage to the battery.

When leaving the motorcycle standing for more than a few days, regularly check the battery Voltage using a digital multimeter. Should the battery Voltage fall below 12.8V, charge the battery using the BatteryMate 150-9. Refer to the instructions supplied with the BatteryMate 150-9.

For extended periods of storage (beyond two weeks) the battery should be removed and the battery Voltage checked regularly and charged when below 12.8V.

## Battery Already in Service

Use the guidelines in the table below for charging. Always verify the battery condition before charging, and 30 minutes after charging.

### Note:

- **A fully charged battery should read 12.8 volts or higher after the battery has been off the charger for 30 minutes or**

**Table of Battery Charging Times**

State of charge	Voltage	Action	Charge time (using BatteryMate 150-9)
100%	12.8V - 13.0V	None. Check at 6 months from date of manufacture	None required
75% - 100%	12.5V - 12.8V	May need slight charge. If no charge given, check in 3 - 4 months	3 - 6 hours
50% - 75%	12.0V - 12.5V	Needs charge	5 - 11 hours
25% - 50% V	11.5V - 12.0V	Needs charge	at least 13 hours
0% - 25%	11.5V or less	Needs recovery using BatteryMate 150-9. Re-test after recovery	20 hours

## Relays

The relay pack is located beneath the rider's seat, adjacent to the fuse boxes. To gain access to the relays, remove the rider's seat (see page 16-13).

### Relay Identification

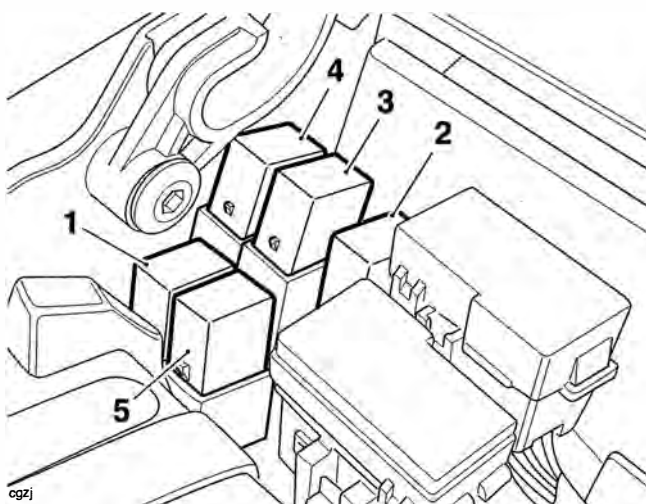

- 1. Cooling fan relay
- 2. Engine management system (EMS) main relay
- 3. Starter relay
- 4. Fuel pump relay
- 5. Headlamp relay

### Direction Indicator Unit

The direction indicator unit is located below the rear rack, adjacent to the rear light unit. To gain access to the relays, remove the rear rack (see page 16-20).

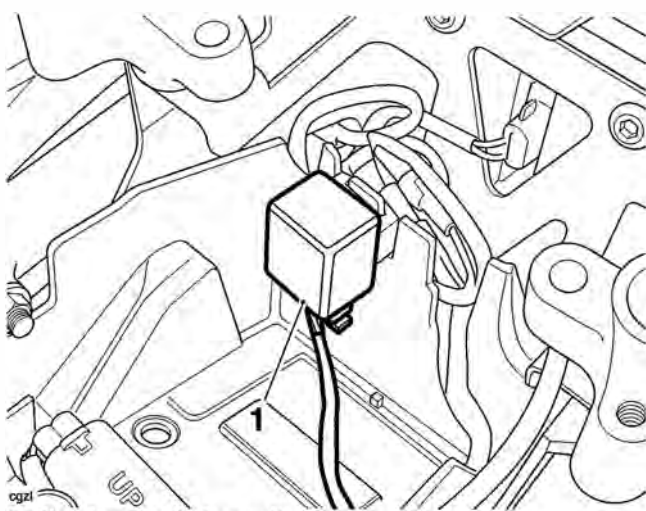

- 1. Direction indicator unit

## Fuses

If a fuse fails during operation, inspect the electrical system to determine the cause, and then replace it with a new fuse of the correct current rating.

A blown fuse is indicated when all of the systems protected by that fuse become inoperative. When checking for a blown fuse, use the table below to establish which fuse has blown.

### Note:

- The starter solenoid has an additional 30 Amp fuse attached directly to the solenoid, beneath the rider's seat.

### Warning

Always replace blown fuses with new ones of the correct current rating (as specified on the fuse box cover) and never use a fuse of higher rating. Use of an incorrect fuse could lead to an electrical problem, resulting in motorcycle damage, loss of motorcycle control and an accident.

### Fuse Identification

The fuse boxes are located beneath the rider's seat.

To allow access to the fuse boxes, the rider's seat must be removed (see page 16-13).

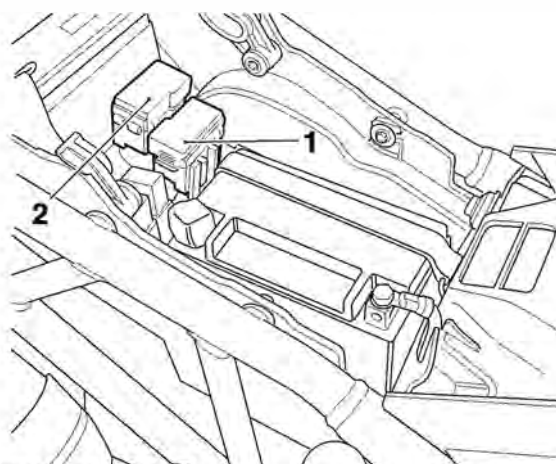

- 1. Front fuse box
- 2. Rear fuse box

# Electrical

## Front fuse box

Fuse No.	Circuits Protected	Fuse Rating
1	Cooling fan	15
2	Accessory lights	15
3	Auxiliary lighting	10
4	Heated grips	10
5	Accessory sockets	15
6	Not used	-

The fuse identification numbers listed correspond with those printed on the fuse box cover.

## Rear fuse box

Fuse No.	Circuits Protected	Fuse Rating
1	ABS	20
2	ABS	20
3	Alarm, instruments, ECM	10
4	Engine management	20
5	Alarm, diagnostic connector, instruments	5
6	Dip and main beam headlights, starter relay	15

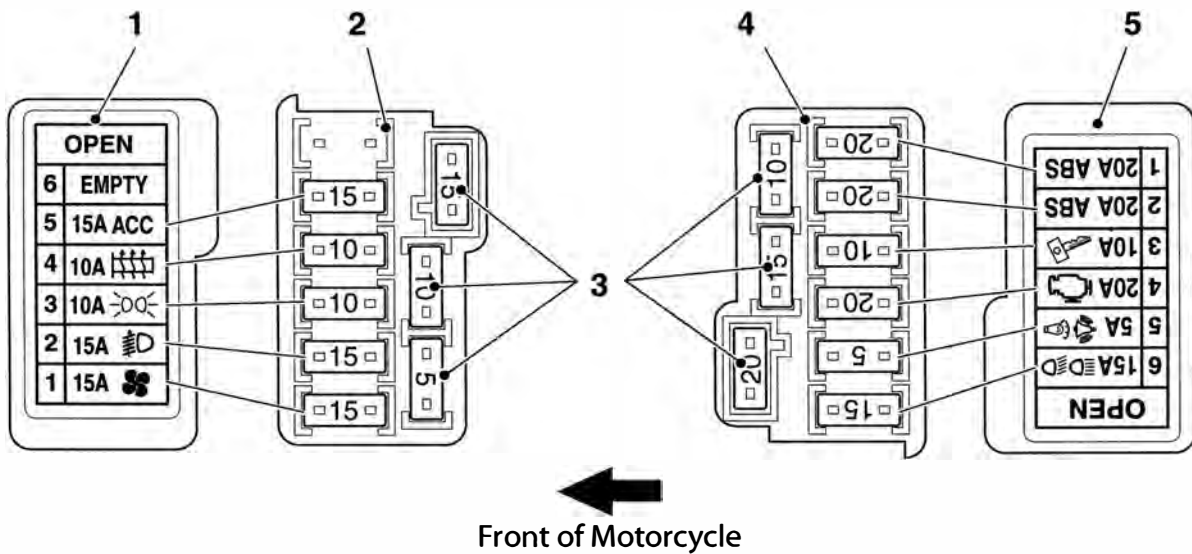

cebw

1. Front fuse box cover
2. Front fuse box
3. Spare fuses
4. Rear fuse box
5. Rear fuse box cover



## Instrument Pack

### Removal

1. Remove the rider's seat (see page 16-13).
2. Disconnect the battery, negative (black) lead first.
3. Remove the windscreen (see page 16-19).
4. Remove the two fixings and remove the screen upper bracket.

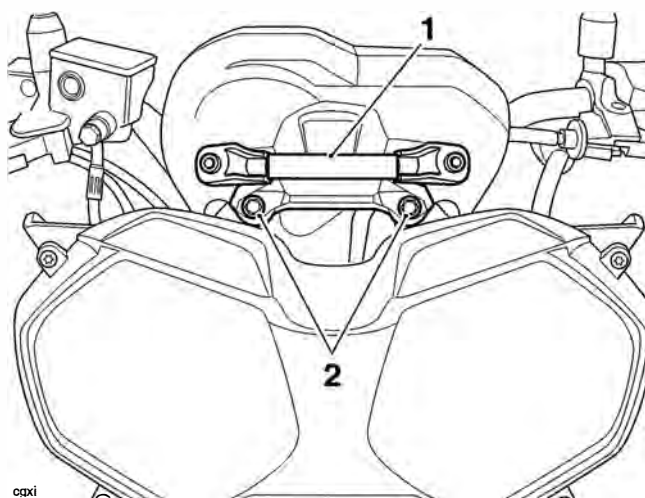

1. Upper screen bracket  
2. Fixings

5. Remove the cover attached to the rear of the instruments.

### Note:

- The cover is held in place by a bayonet type fixing. Gently pull on the cover to release it.

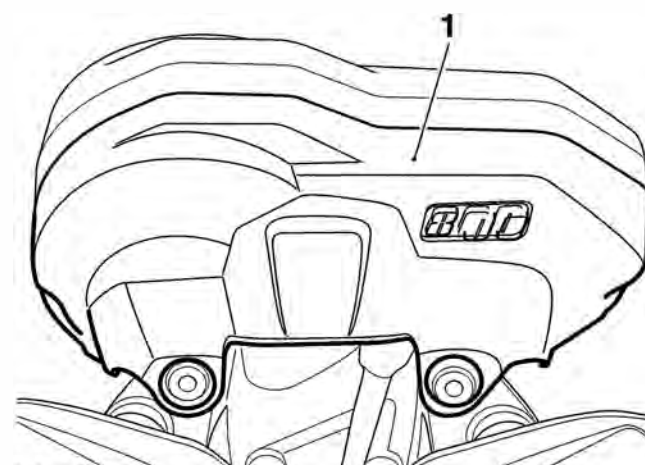

1. Instrument cover

6. Disconnect the electrical connector from the instruments.

7. Remove the screw and release the instrument pack from the bracket bayonet fixings.

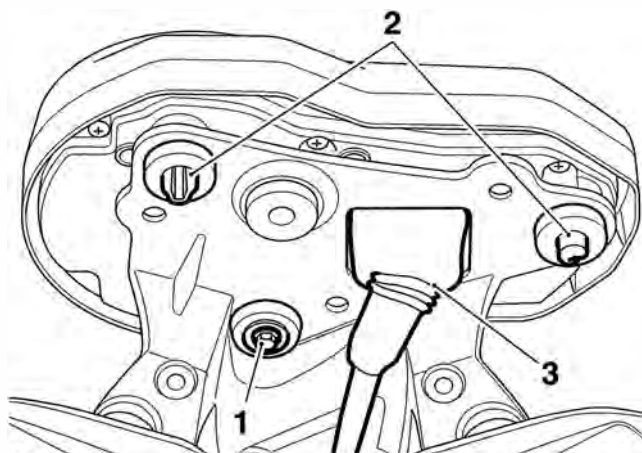

1. Screw  
2. Bayonet fixings  
3. Electrical connector

### Installation

1. Position the instrument pack to the bracket.
2. Insert the bayonet fixings into the grommets.
3. Refit the fixing and tighten to **2 Nm**.
4. Connect the instruments to the harness.

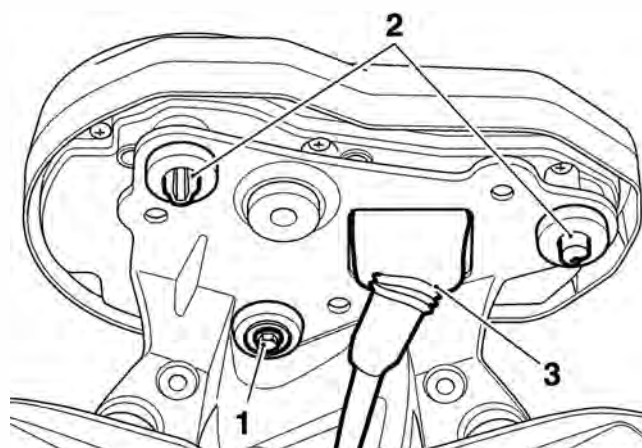

1. Screw  
2. Bayonet fixings  
3. Electrical connector

5. Install the cover and gasket to the rear of the instruments, ensuring the bayonet fixing is fully inserted in the grommets on the instrument bracket.
6. Refit the screen upper bracket and tighten the two fixings to **3 Nm**.
7. Refit the windscreen (see page 16-21).
8. Reconnect the battery, positive (red) lead first.
9. Refit the rider's seat (see page 16-13).

## Headlights

### Headlight Adjustment

#### Note:

- The headlight can be adjusted by means of vertical and horizontal adjustment screws located on the rear of the headlight.

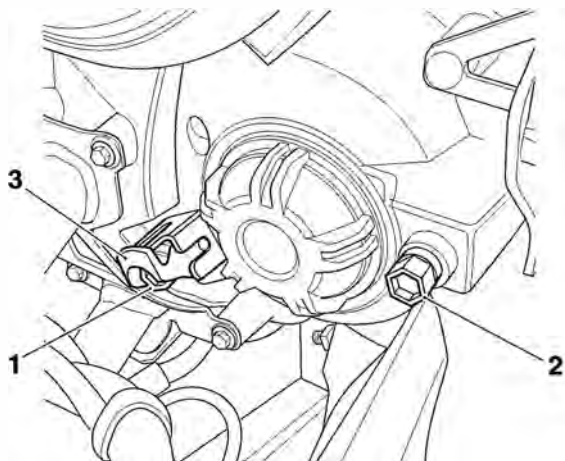

1. Horizontal adjustment screw
2. Vertical adjustment screw
3. Headlight adjuster lever for loaded conditions

1. Switch the headlight dipped beam on.
2. Turn the vertical adjustment screw on the headlight clockwise to raise the beam or anti-clockwise to lower the beam.
3. Turn the horizontal adjustment screw clockwise to move the beam to the right or anti-clockwise to move the beam to the left.
4. Switch the headlights off when the beam settings are satisfactory.

#### Warning

Adjust road speed to suit the visibility and weather conditions in which the motorcycle is being operated. Ensure that the beam is adjusted to illuminate the road surface sufficiently far ahead without dazzling oncoming traffic. An incorrectly adjusted headlight may impair visibility causing an accident.

#### Warning

Never attempt to adjust a headlight beam when the motorcycle is in motion. Any attempt to adjust a headlight beam when the motorcycle is in motion may result in loss of control and an accident.

### Headlight Bulb Replacement

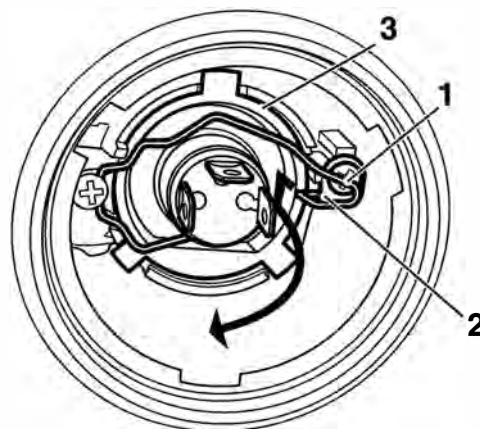

1. Bulb retainer (right hand shown)
2. Bulb retainer hook
3. Bulb

Each headlight bulb can be replaced as follows:

#### Warning

The bulb becomes hot during use. Always allow sufficient time for the bulb to cool before handling. Avoid touching the glass part of the bulb. If the glass is touched or gets dirty, clean with alcohol before re-use.

#### Warning

Do not reconnect the battery until the assembly process has been completed. Premature battery reconnection could result in ignition of the battery gases causing risk of injury.

1. Remove the rider's seat (see page 16-13).
2. Disconnect the battery, negative (black) lead first.
3. Remove the bulb cover from the bulb to be replaced by rotating it anti-clockwise.
4. Disconnect the multi-plug from the bulb retainer.
5. Detach the bulb retainer from the hook on the headlight assembly and rotate it away from the bulb as shown.
6. Remove the bulb from the bulb retainer.

### Installation

1. Installation is the reverse of removal, noting the following:

#### Note:

- When reconnecting the battery, connect the positive (red) lead first.

## Position Lamp Bulb Replacement

### Note:

- **The position lamp is fitted to the centre of the headlight.**

1. Remove the rider's seat (see page 16-13).
2. Disconnect the battery, negative (black) lead first.
3. Remove the four fixings and remove the headlight surround.

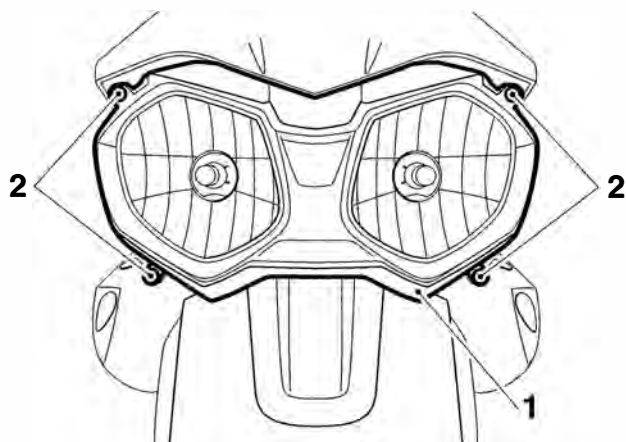

1. Headlamp surround

2. Fixings

4. Detach the rubber retainer from the headlight and pull out the bulb.

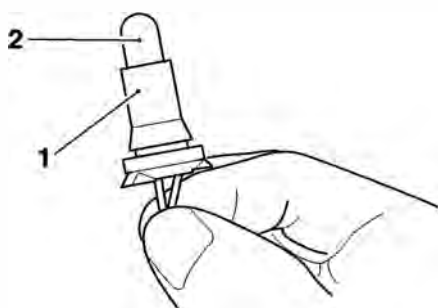

1. Bulb retainer

2. Position lamp bulb

### Installation

1. Installation is the reverse of removal, noting the following:

### Note:

- **Tighten the headlight surround fixings to 3 Nm.**
- **Reconnect the battery, positive (red) lead first.**

## Headlight Assembly

### Removal

1. Remove the rider's seat (see page 16-13).
2. Disconnect the battery, negative (black) lead first.
3. Remove the windscreen (see page 16-19).
4. Remove the cockpit assembly (see page 16-17).
5. Release the four fixings securing the headlight to the front subframe.
6. Disconnect the electrical connector and remove the headlight.

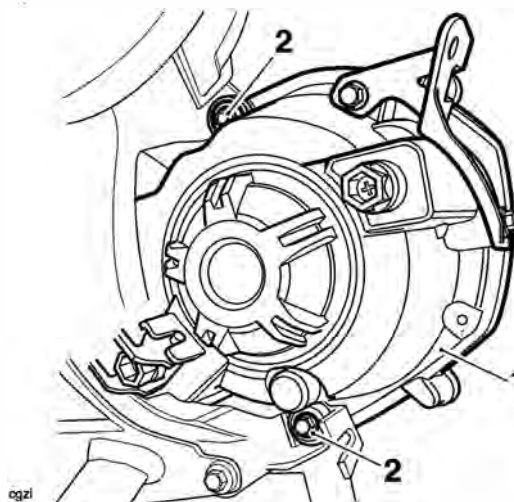

1. Headlight

2. Fixings (right hand shown)

### Installation

1. Installation is the reverse of removal, noting the following:

### Note:

- **Tighten the headlight fixings to 3.5 Nm.**
- **Reconnect the battery, positive (red) lead first.**

## Rear Light

### Removal

#### Note:

- **The rear light is a sealed for life unit and must be replaced in the event of a failure.**

1. Remove the seats (see page 16-13).
2. Disconnect the battery, negative (black) lead first.
3. Remove the rear mudguard (see page 16-22).
4. Disconnect the electrical connector.
5. Release the fixings securing the light unit to the rear light bracket.

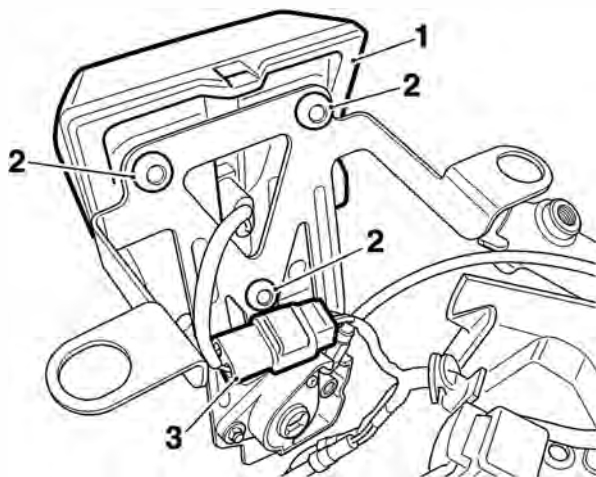

1. Rear light unit
2. Rear light fixings
3. Electrical connector

6. Remove the rear light.

### Installation

1. Installation is the reverse of the removal procedure, noting the following:

#### Note:

- **Tighten the rear light fixings to 4 Nm.**
- **Reconnect the battery, positive (red) lead first.**

## Direction Indicators

### Bulb Replacement

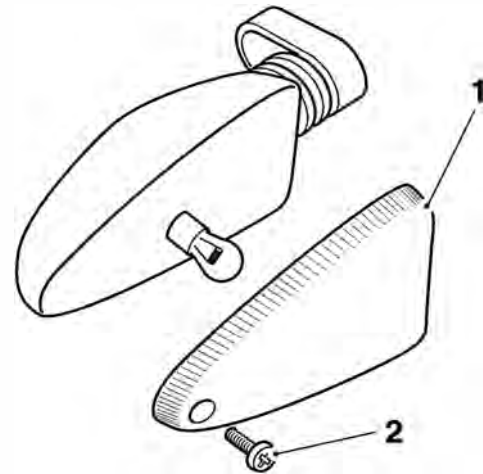

1. Direction indicator lens
2. Screw

The lens on each direction indicator is held in place by a securing screw located in the lens of the light.

Release the screw and remove the lens to gain access to the bulb for replacement.

## Rear Direction Indicator

### Removal

1. Remove the seat (see page 16-13).
2. Disconnect the battery, negative (black) lead first.
3. Remove the rear rack (see page 16-20).
4. Release the fixing securing the direction indicator to the rear mudguard and detach the direction indicator.
5. Disconnect the direction indicator electrical connectors.

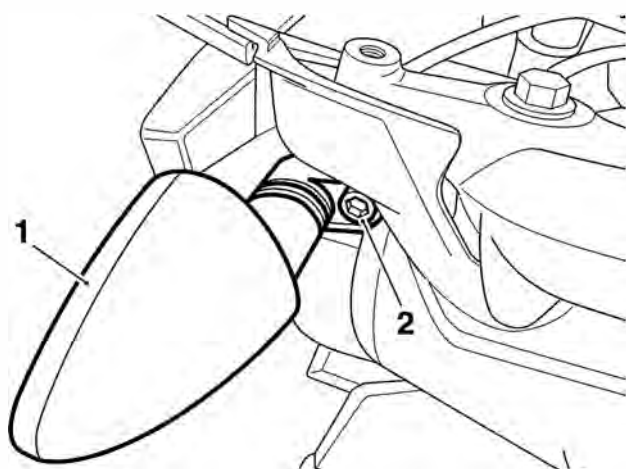

1. Direction indicator
2. Fixing

### Installation

1. Installation is the reverse of the removal procedure, noting the following.

#### Note:

- Tighten the direction indicator fixing to 3 Nm.
- Tighten the rear rack fixings to 3 Nm.
- Reconnect the battery, positive (red) lead first.

## Front Direction Indicator

### Removal

1. Remove the rider's seat (see page 16-13).
2. Disconnect the battery, negative (black) lead first.
3. Remove the upper radiator panel (see page 16-14).
4. Release the fixing securing the direction indicator to the upper radiator panel and remove the unit.

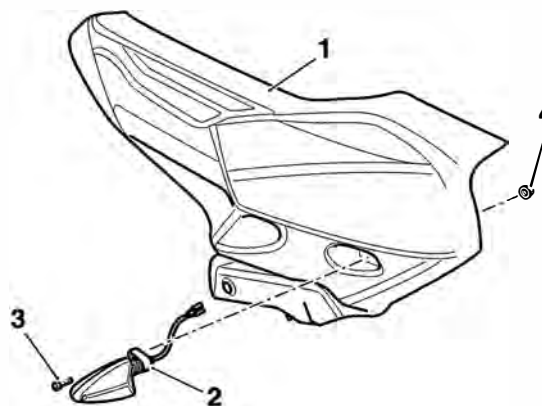

1. Upper radiator panel
2. Direction indicator (right hand shown)
3. Direction indicator fixing
4. Nut

### Installation

1. Installation is the reverse of the removal procedure, noting the following.

#### Note:

- Tighten the direction indicator fixing to 3 Nm.
- Reconnect the battery, positive (red) lead first.

## Starter Motor

### Removal

1. Remove the rider's seat (see page 16-13).
2. Disconnect the battery, negative (black) lead first.
3. Remove the fuel tank (see page 10-91).
4. Remove the airbox (see page 10-98).
5. Remove the throttle bodies (see page 10-107).
6. Disconnect the low oil pressure warning light switch.
7. Ease the boot from the starter cable terminal and then release the cable bolt.
8. Detach the cable.
9. Release the fixings securing the starter motor to the crankcase.

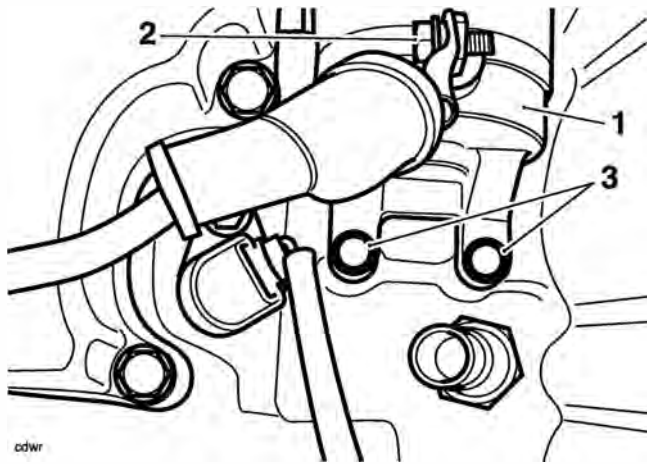

1. Starter motor
2. Starter cable fixing
3. Fixings

10. Ease the starter motor from the upper crankcase.

### Inspection

1. Ensure the starter turns freely and without binding.
2. Check the starter O-ring for damage and deterioration. Replace as necessary.

### Installation

1. Lubricate the starter motor O-ring with a small amount of petroleum jelly
2. Fit the starter motor to the upper crankcase ensuring that the O-ring does not become damaged during installation.
3. Fit and tighten the starter bolts to **10 Nm**.
4. Refit the starter cable and secure with the bolt. Tighten to **3 Nm**.
5. Refit the starter cable boot.
6. Connect the low oil pressure warning light switch.
7. Refit the throttle bodies (see page 10-101).
8. Refit the airbox (see page 10-101)
9. Refit the fuel tank (see page 10-92).
10. Reconnect the battery, positive (red) lead first.
11. Refit the rider's seat (see page 16-13).

## Alternator

### Removal

1. Remove the rider's seat (see page 16-13).
2. Disconnect the battery, negative (black) lead first.
3. Remove the starter motor (see page 17-18).
4. Release the bolts securing the left hand engine cover. Collect the bottom hose bracket from under the front two bolts.  
Note the positions of the two different bolt lengths. Discard the 35 mm bolts.

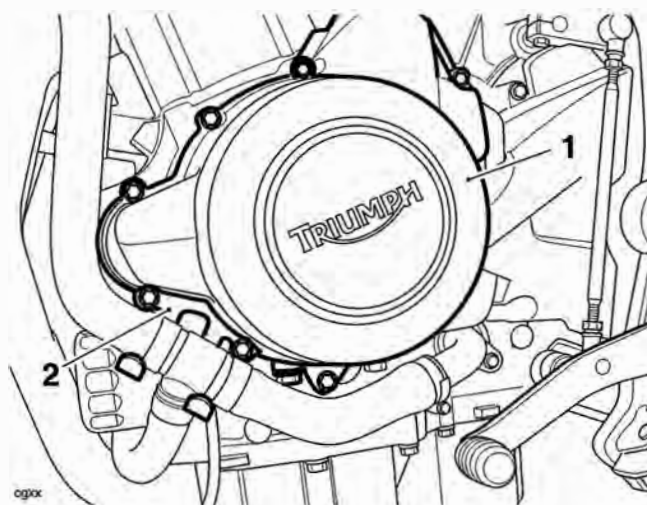

**1. Left hand engine cover**  
**2. Bottom hose bracket**

5. Withdraw the cover from the crankcase against the pull of the alternator magnet.
6. To remove the stator from the cover, release the three bolts in the centre of the cover and release the bolt securing the cable bracket. Discard the bolts.

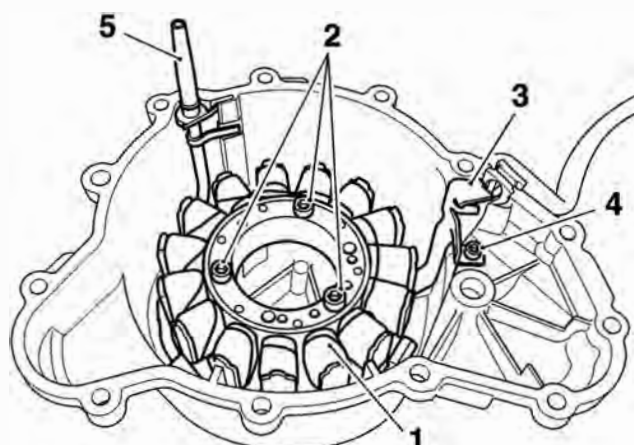

**1. Stator**  
**2. Stator fixings**  
**3. Cable bracket**  
**4. Cable bracket fixing**  
**5. Alternator spray bar**

7. Withdraw the stator.



### Caution

Do not use tools to tighten service tool T3880375. Tighten the tool by hand only. Over-tightening of the tool will lead to damage to the alternator rotor.

8. To remove the rotor, clean the alternator rotor to remove all traces of oil, and fit tool T3880375 to the rotor as shown below. Retain the tool to prevent the crankshaft from rotating and remove the centre bolt from the crankshaft.

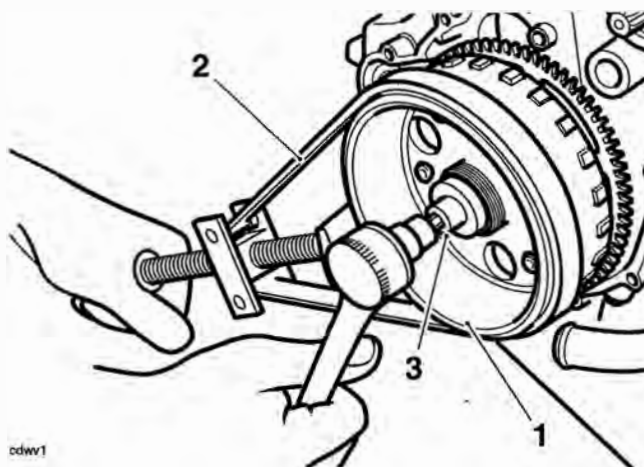

cdww1

**1. Rotor**  
**2. Tool T3880375**  
**3. Centre bolt**

9. With the bolt removed, locate the spigot from the larger of the two thrust pads supplied with tool T3880365 to the crankshaft.

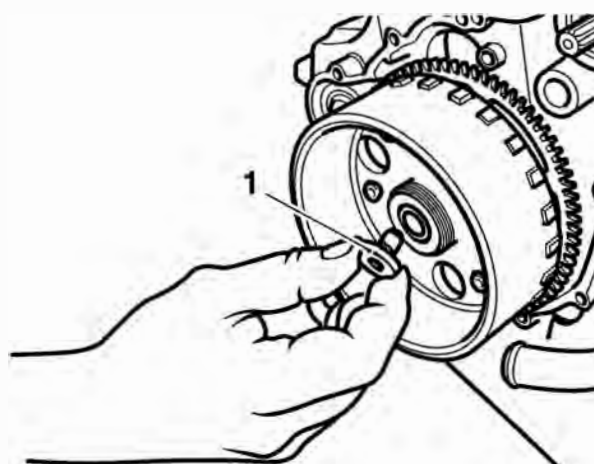

cdww1

- 1. Thrust pad**
10. Assemble tool T3880365 to the threaded centre section of the rotor.

# Electrical

## Note:

- **Ensure that the thrust pad does not fall out during assembly of the tool.**
11. Hold the centre of the tool to prevent rotation then tighten the draw-bolt in the centre of the tool to release the taper seating of the rotor from the crankshaft.

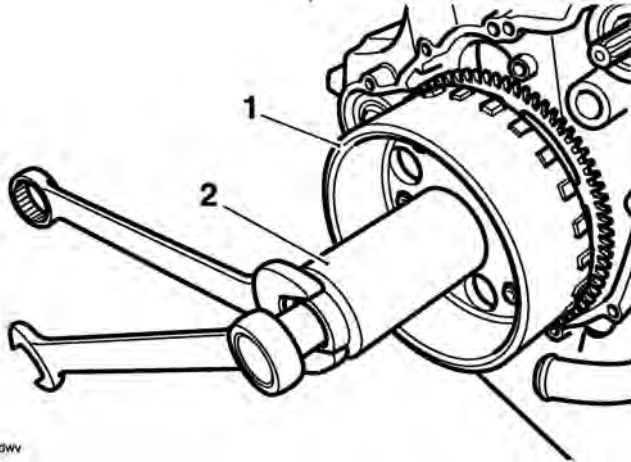

cdwv

### 1. Rotor

### 2. Tool T3880365

12. Withdraw the rotor and tool as an assembly and then separate the tool from the rotor. Collect the Woodruff Key and the tool thrust pad from the crankshaft.

## Assembly

1. Refit the Woodruff key to the crankshaft.
2. Assemble the rotor to the keyway on the crankshaft, ensuring the Woodruff key remains in position.



## Caution

Do not use tools to tighten service tool T3880375. Tighten the tool by hand only. Over-tightening of the tool will lead to damage to the alternator rotor.

3. Refit tool T3880375 to prevent the crankshaft from rotating, ensuring the rotor is free from oil and the tool is not over-tightened.
4. Tighten the rotor retaining bolt to **120 Nm**.

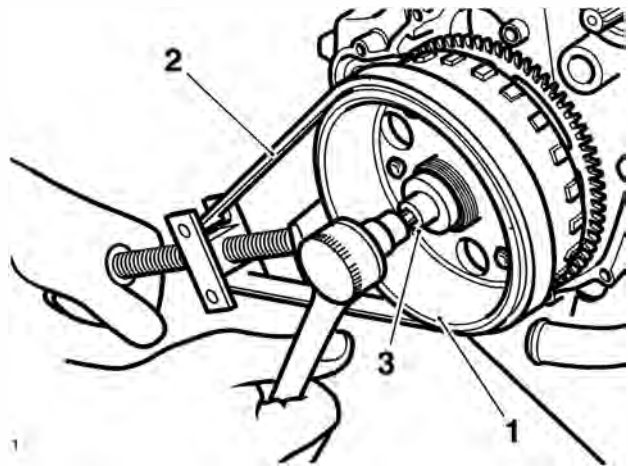

### 1. Rotor

### 2. Tool T3880375

### 3. Centre bolt

5. Remove tool T3880375.
6. Install a new O-ring to the alternator spray bar.
7. Locate the stator to the engine cover.
8. Fit the cable retainer bracket and tighten a new retainer bolt to **6 Nm**.
9. Tighten the new stator bolts to **12 N m**.



10. Position a new gasket to the crankcase dowels then refit the left hand engine cover.
11. Refit the bottom hose bracket to the front two bolts. Install the bolts, using new 35 mm bolts positioned as noted during removal (the 25 mm bolts may be re-used).  
Tighten the 25 mm fixings to **8 Nm**, and the 35 mm fixings to **9 Nm**.

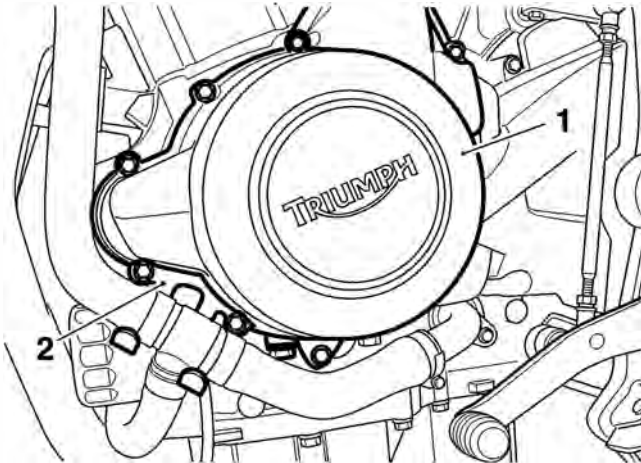

**1. Left hand engine cover**

**2. Bottom hose bracket**

12. Refit the starter motor (see page 17-18).
13. Reconnect the battery, positive (red) lead first.
14. Refit the rider's seat (see page 16-13).

## Alternator Rectifier

The rectifier does not contain any serviceable parts and must be replaced if faulty.

The alternator rectifier is located under the head stock, behind the radiator. To access the rectifier, remove the radiator (see page 10-91).

## Alternator Stator

The stator is an assembly of 18 coils, arranged into three phases. It is possible to check for continuity and short circuits through the coils and to earth.

### Note:

- **Only repair the stator harness between the rectifier and where the harness goes into the crankcase.**
- **Do not attempt to repair the stator coils.**
- **If the battery is not fully charged, the charging voltage may be lower than specified when checking at 2,000 rpm.**
- **Ensure all additional accessories (auxiliary lights, heated grips etc.) are switched off.**

Fault	Possible cause	Action
Battery not charging	Battery	Check the condition of the battery. Test the battery using the BatteryMate 150-9. Refer to the instructions supplied with the BatteryMate 150-9. Ensure the battery is serviceable:-
	Alternator	Proceed to pinpoint test 1:-
	Rectifier/Regulator	Test the rectifier/regulator (see page 17-24)

### Pinpoint Tests

Test	Result	Action
1 Check cable and terminal integrity: - Battery positive (+) - Battery negative (-) - Rectifier/regulator black connector pin 1 - Rectifier/regulator black connector pin 3 - Rectifier/regulator grey connector pin 1 - Rectifier/regulator grey connector pin 2 - Rectifier/regulator grey connector pin 3	OK	Disconnect the battery leads, negative (black) lead first. Disconnect rectifier/regulator black connector and proceed to test 2
	Faulty	Rectify fault, proceed to test 4
2 Check cable continuity - Rectifier/regulator black connector pin 1 to battery lead negative connector - Rectifier/regulator black connector pin 3 to battery lead positive connector	OK	Reconnect the battery leads, positive (red) lead first. Reconnect the rectifier/regulator black connector. Disconnect the rectifier/regulator grey connector and proceed to test 3
	Open circuit	Locate and rectify wiring fault, proceed to test 4
3 Check resistance through the coils: - Alternator pin 1 to pin 2 - Alternator pin 2 to pin 3 - Alternator pin 3 to pin 1	0.14Ω to 0.18Ω	Proceed to test 4
	Open circuit or short circuit	If the fault is between the rectifier and the crankcase, repair the harness. Proceed to test 4 If the fault is after the crankcase, replace the unit. Proceed to test 5
4 Reconnect the harness and run the engine. Check the charging Voltage at 2,000 rpm:	13.5V - 15V	Action complete - quit test
	Fault still present	Disconnect the rectifier/regulator grey connector and proceed to test 5

Test	Result	Action	
5	Check the alternator AC output Voltage at 850 rpm by probing the 3-pin stator connector as follows: - Positive (+) probe to pin 1 negative (-) probe to pin 2 - Positive (+) probe to pin 2 negative (-) probe to pin 3 - Positive (+) probe to pin 3 negative (-) probe to pin 1	15V AC to 25V AC	Test rectifier/regulator (see page 17-24)
		Less than 15V AC	Replace unit. Proceed to test 6
6	Reconnect the harness and run the engine. Check the charging Voltage at 2,000 rpm:	13.5V - 15V	Action complete - quit test
		Fault still present	Contact Triumph service

## Circuit Diagram

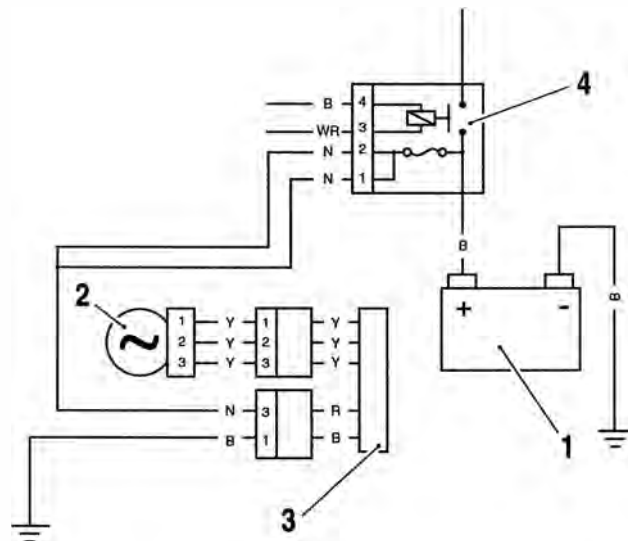

1. Battery
2. Alternator
3. Rectifier/Regulator
4. Starter relay

# Electrical

## Rectifier/Regulator

Internally the rectifier/regulator consists of three diodes, one between each input and the positive terminal, and three Field Effect Transistors (FETs), one between each input and the ground terminal.

As the voltage of the AC signal from the generator rises, the voltage controller switches the FETs to avoid over voltage on the output.

The diodes and FETs can be checked using a multimeter on DIODE setting. Disconnect the two electrical connectors from the rectifier/regulator and check the readings as indicated below.

### Note:

- **This test does not check for voltage regulation.**

Fault	Possible cause	Action
Battery not charging	Fuse 11	Check the condition of fuse 11:-
	Battery	Check the condition of the battery. Test the battery using the BatteryMate 150-9. Refer to the instructions supplied with the BatteryMate 150-9. Ensure the battery is serviceable:-
	Rectifier/Regulator	Disconnect the black and the grey connectors from the rectifier/regulator and proceed to pinpoint test 1:-
	Alternator	Test the alternator stator (see page 17-22)

### Pinpoint Tests

Test	Result	Action
1 Check diodes forward bias: - Positive (+) probe to rectifier black socket pin 1 to: Negative (-) probe to rectifier grey socket pin 1 Negative (-) probe to rectifier grey socket pin 2 Negative (-) probe to rectifier grey socket pin 3	0.4V to 0.7V	Proceed to test 2
	Open circuit or short circuit	Replace the unit. Proceed to test 4
2 Check FET function forward bias: - Negative (-) probe to rectifier black socket pin 3 to: Positive (+) probe to rectifier grey socket pin 1 Positive (+) probe to rectifier grey socket pin 2 Positive (+) probe to rectifier grey socket pin 3	0.1V to 0.3V	Proceed to test 3
	Open circuit or short circuit	Replace the unit. Proceed to test 4
3 Check diodes reverse bias: - Negative (-) probe to rectifier black socket pin 1 to: Positive (+) probe to rectifier grey socket pin 1 Positive (+) probe to rectifier grey socket pin 2 Positive (+) probe to rectifier grey socket pin 3 - Positive (+) probe to rectifier black socket pin 3 to: Negative (-) probe to rectifier grey socket pin 1 Negative (-) probe to rectifier grey socket pin 2 Negative (-) probe to rectifier grey socket pin 3	More than 1.4V or OL on meter	Proceed to test 4
	Less than 1.4V or short circuit	Replace the unit. Proceed to test 4

Test	Result	Action
4 Reconnect the harness and run the engine. Check the charging Voltage at 2,000 rpm:	13V - 15V	Action complete - quit test
	Fault still present	Test alternator stator (see page 17-22)
		If alternator stator is serviceable, contact Triumph service

## Circuit Diagram

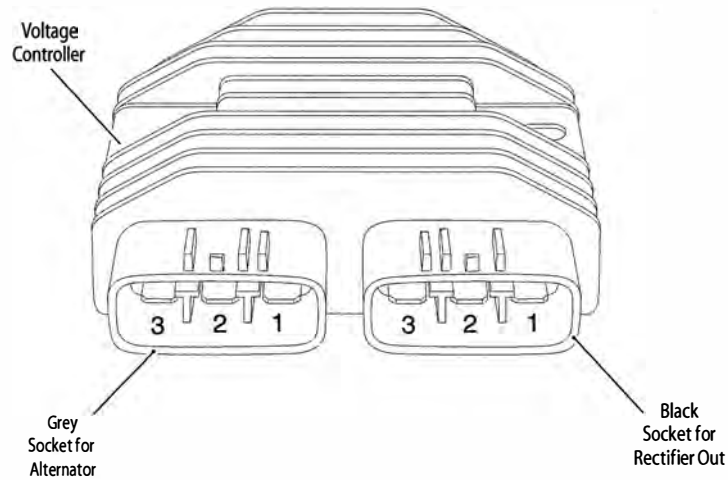
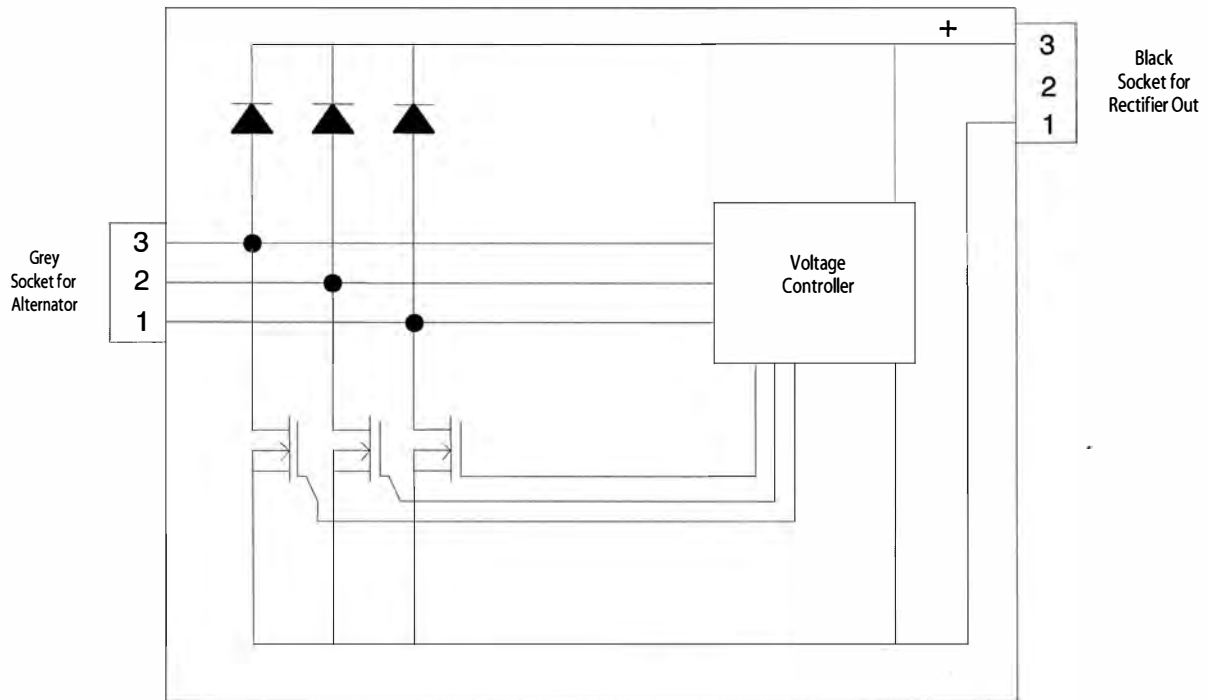

# Electrical

---

## Lighting Circuit

### Key to circuit diagram

Key	Item Description
1	Fuses (Front, Fuses 2 And 3)
2	Ignition Switch
3	Rear Light
4	Instrument Assembly
5	Oil Pressure LED
6	Oil Pressure Switch
7	Main Beam LED
8	Headlights
9	Pass Light Switch
10	Headlight Switch
11	Left Hand Switch Cube
12	Heated Grips
13	Headlight Relay
14	Starter Relay
15	Accessory Lights

### Key to wiring colours

Key	Wiring Colour
B	Black
U	Blue
N	Brown
G	Green
S	Slate / Grey
O	Orange
K	Pink
R	Red
P	Purple
W	White
Y	Yellow
LG	Light Green
LU	Light Blue

Lighting Circuit

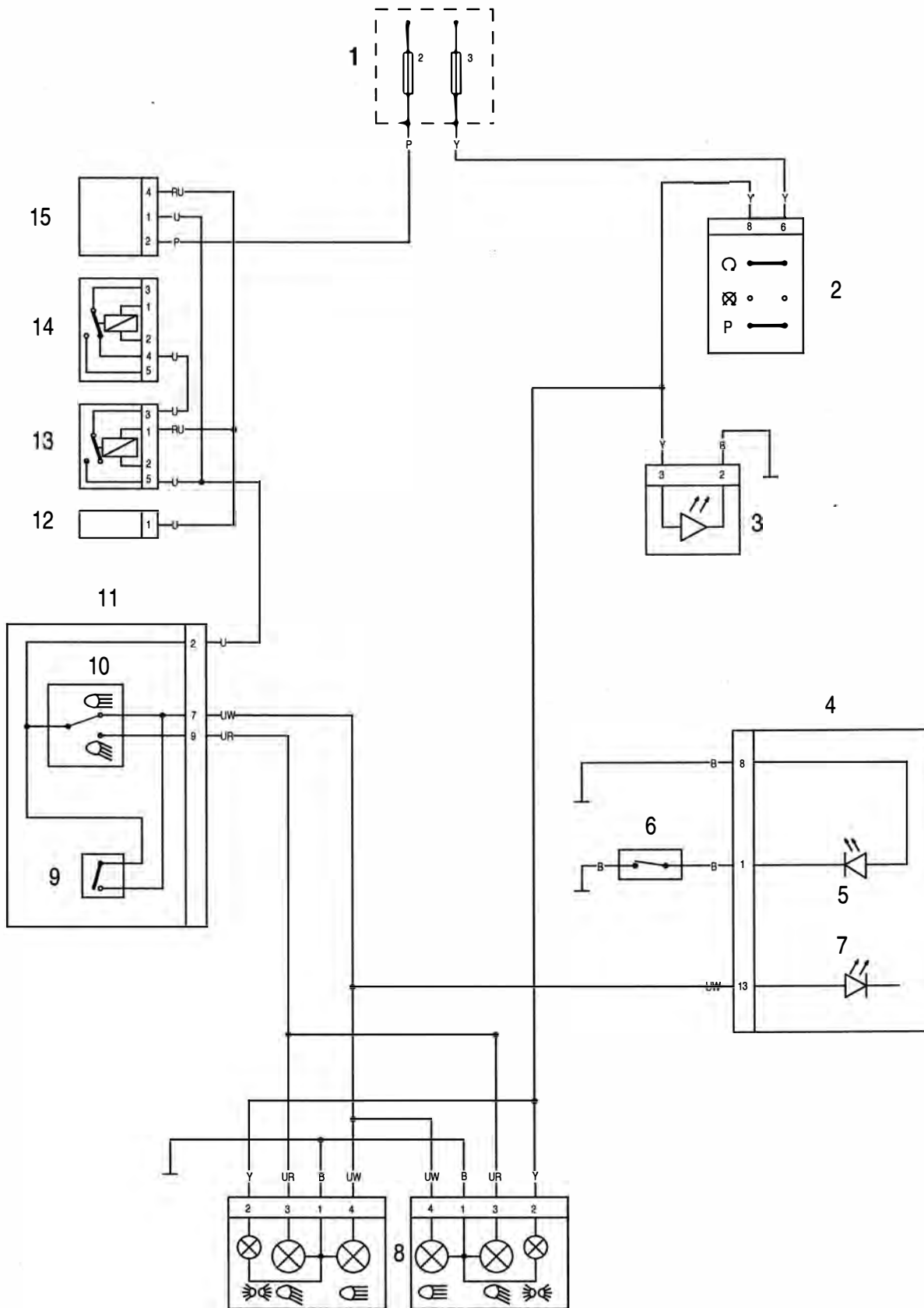

# Electrical

---

## Starting and Charging Circuit

### Key to circuit diagram

Key	Item Description
1	Battery
2	Starter Solenoid
3	Starter Motor
4	Regulator/Rectifier
5	Fuse Box (Rear)
6	Fuse Box (Front)
7	Starter Relay
8	Engine Control Module Relay
9	Cooling Fan Relay
10	Fuel Pump Relay
11	ECM Connector B
12	ECM Connector A
13	Alarm
14	Starter Switch
15	Engine Stop Switch
16	Ignition Switch
17	Instrument Assembly
18	Immobiliser

### Key to wiring colours

Key	Wiring Colour
B	Black
U	Blue
N	Brown
G	Green
S	Slate / Grey
O	Orange
K	Pink
R	Red
P	Purple
W	White
Y	Yellow
LG	Light Green
LU	Light Blue



Starting and Charging Circuit

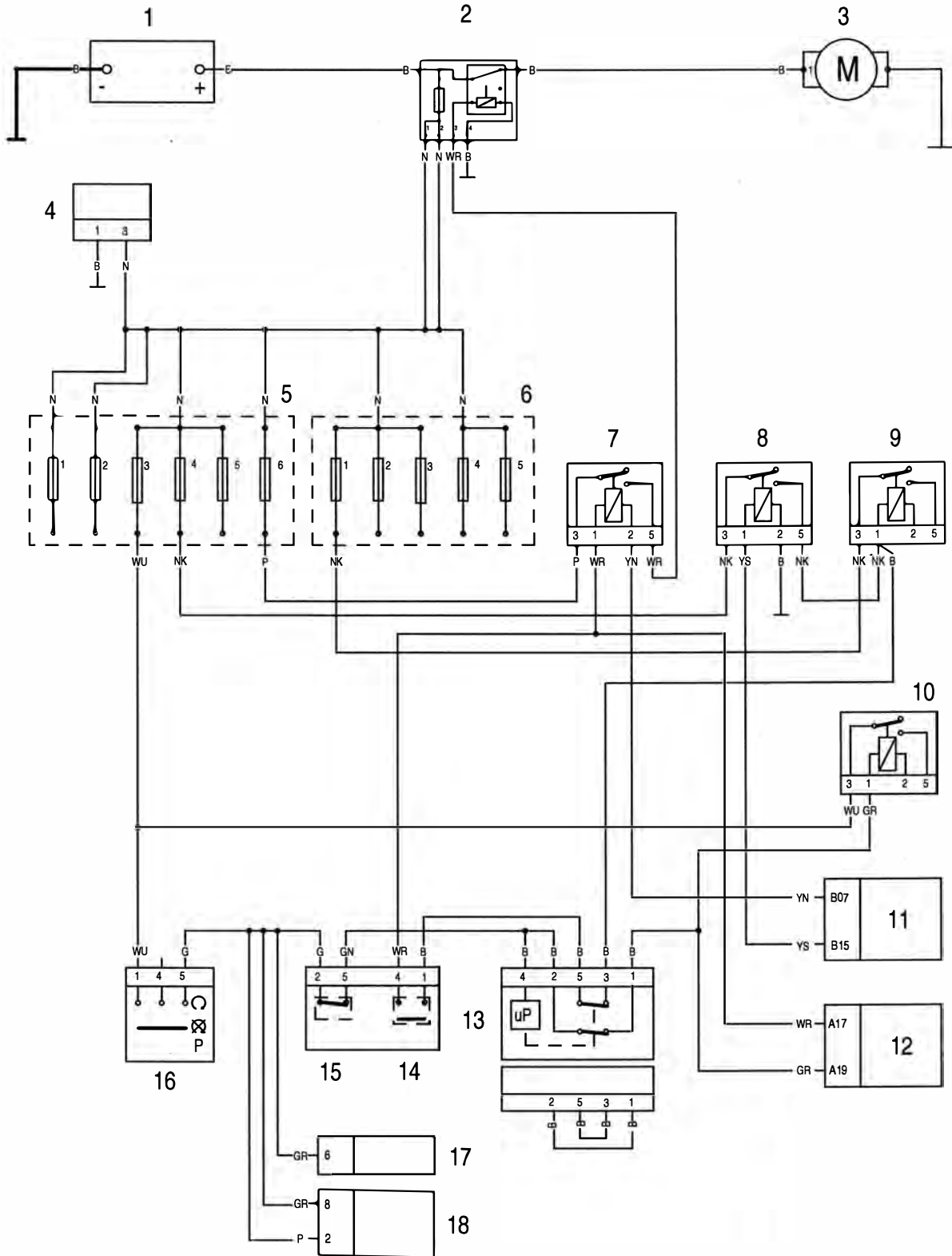

# Electrical

## Auxiliary and Accessory Circuit

### Key to circuit diagram

Key	Item Description
1	Fuse box (Front)
2	Accessory Socket 1
3	Accessory Socket 2
4	Heated Grips
5	Front Brake Light Switch
6	Brake Light
7	Rear Brake Light Switch
8	Rear Left Direction Indicator
9	Rear Right Direction Indicator
10	Alarm
11	Front Left Direction Indicator
12	Front Right Direction Indicator
13	Alarm LED
14	Direction Indicator (Instruments)
15	Instrument Assembly
16	Direction Indicator Switch
17	Horn Switch
18	Horn
19	Direction Indicator Relay
20	Diagnostic Connector

### Key to wiring colours

Key	Wiring Colour
B	Black
U	Blue
N	Brown
G	Green
S	Slate / Grey
O	Orange
K	Pink
R	Red
P	Purple
W	White
Y	Yellow
LG	Light Green
LU	Light Blue

Auxiliary and Accessory Circuit

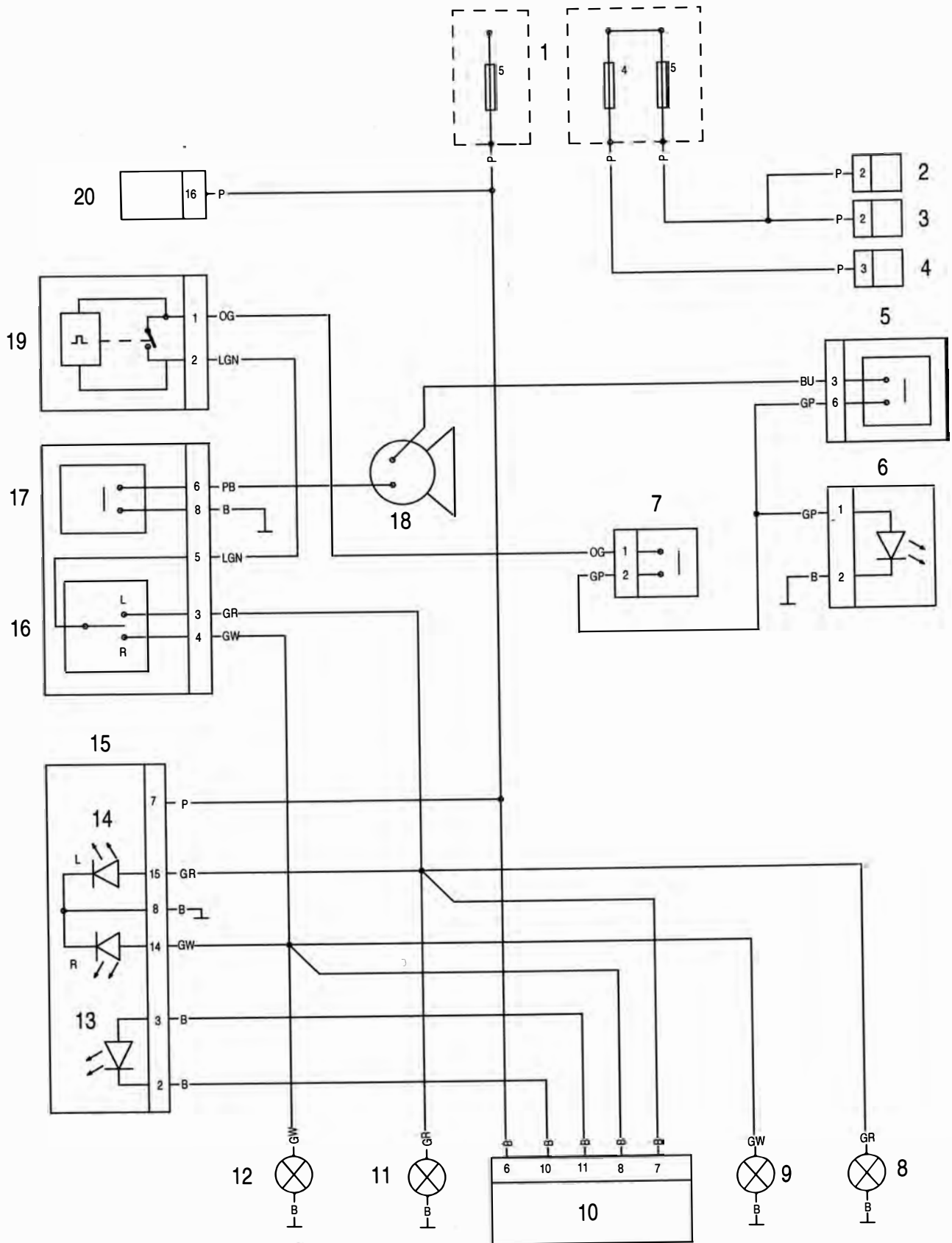

# Electrical

## Engine Management Circuit Diagram - Tiger 800 and Tiger 800XC

### Key To Wiring Circuit Diagram

Key	Item Description
1	Engine Control Module
2	Diagnostic Connector
3	Road Speed Sensor
4	Instrument Assembly
5	Clutch Switch
6	Immobiliser
7	Sidestand Switch
8	Ignition Switch
9	Fuel Level Sensor
10	Fall Detection Switch
11	Barometric Pressure Sensor
12	Intake Air Temperature Sensor
13	MAP Sensor
14	Coolant Temperature Sensor
15	Oxygen (Lambda) Sensor
16	Throttle Position Sensor
17	Gear Position Sensor
18	Fuel Pump
19	Fuel Pump Relay
20	Cooling Fan
21	Cooling Fan Relay
22	Idle Speed Control Stepper Motor
23	Coil 3
24	Coil 2
25	Coil 1
26	Oxygen (Lambda) Sensor Heater
27	Fuel Injector 3
28	Fuel Injector 2
29	Fuel Injector 1
30	Purge Valve
31	Crankshaft Position Sensor
32	Engine Control Module Relay

### Key To Wiring Colour Codes

Code	Wiring Colour
B	Black
U	Blue
N	Brown
G	Green
S	Slate/Grey
O	Orange
K	Pink
R	Red
P	Purple
W	White
Y	Yellow
LG	Light Green
LU	Light Blue

## Engine Management Circuit Diagram - Tiger 800 and Tiger 800XC

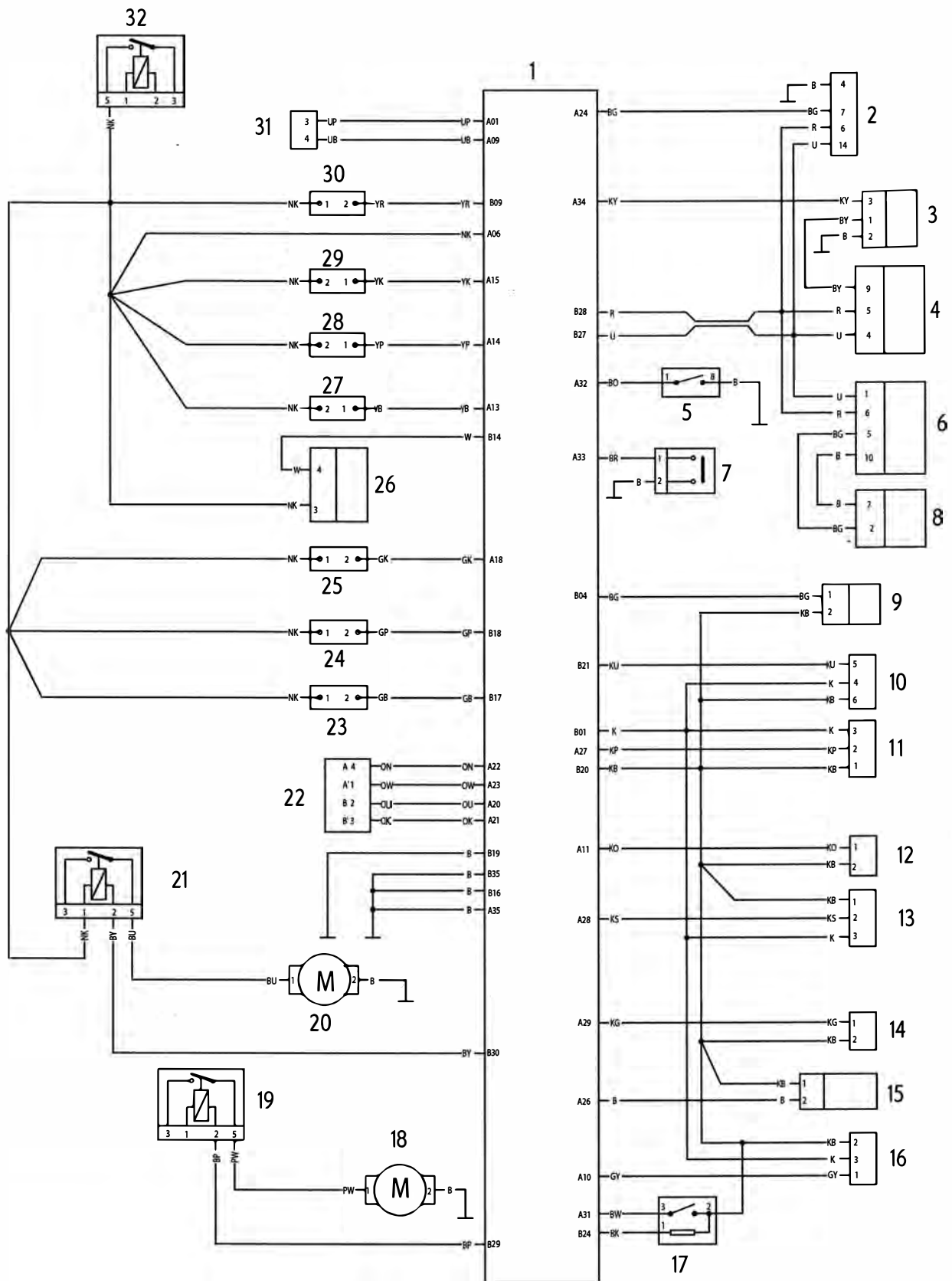

# Electrical

## Engine Management Circuit Diagram - Tiger 800 (ABS) and Tiger 800XC (ABS)

### Key To Wiring Circuit Diagram

Key	Item Description
1	Engine Control Module
2	Diagnostic Connector
3	ABS Modulator
4	Instrument Assembly
5	Clutch Switch
6	Immobiliser
7	Sidestand Switch
8	Ignition Switch
9	Fuel Level Sensor
10	Fall Detection Switch
11	Barometric Pressure Sensor
12	Intake Air Temperature Sensor
13	MAP Sensor
14	Coolant Temperature Sensor
15	Oxygen (Lambda) Sensor
16	Throttle Position Sensor
17	Gear Position Sensor
18	Fuel Pump
19	Fuel Pump Relay
20	Cooling Fan
21	Cooling Fan Relay
22	Idle Speed Control Stepper Motor
23	Coil 3
24	Coil 2
25	Coil 1
26	Oxygen (Lambda) Sensor
27	Fuel Injector 3
28	Fuel Injector 2
29	Fuel Injector 1
30	Purge Valve
31	Crankshaft Position Sensor
32	Engine Control Module Relay

### Key To Wiring Colour Codes

Code	Wiring Colour
B	Black
U	Blue
N	Brown
G	Green
S	Slate/Grey
O	Orange
K	Pink
R	Red
P	Purple
W	White
Y	Yellow
LG	Light Green
LU	Light Blue

## Engine Management Circuit Diagram - Tiger 800 (ABS) and Tiger 800XC (ABS)

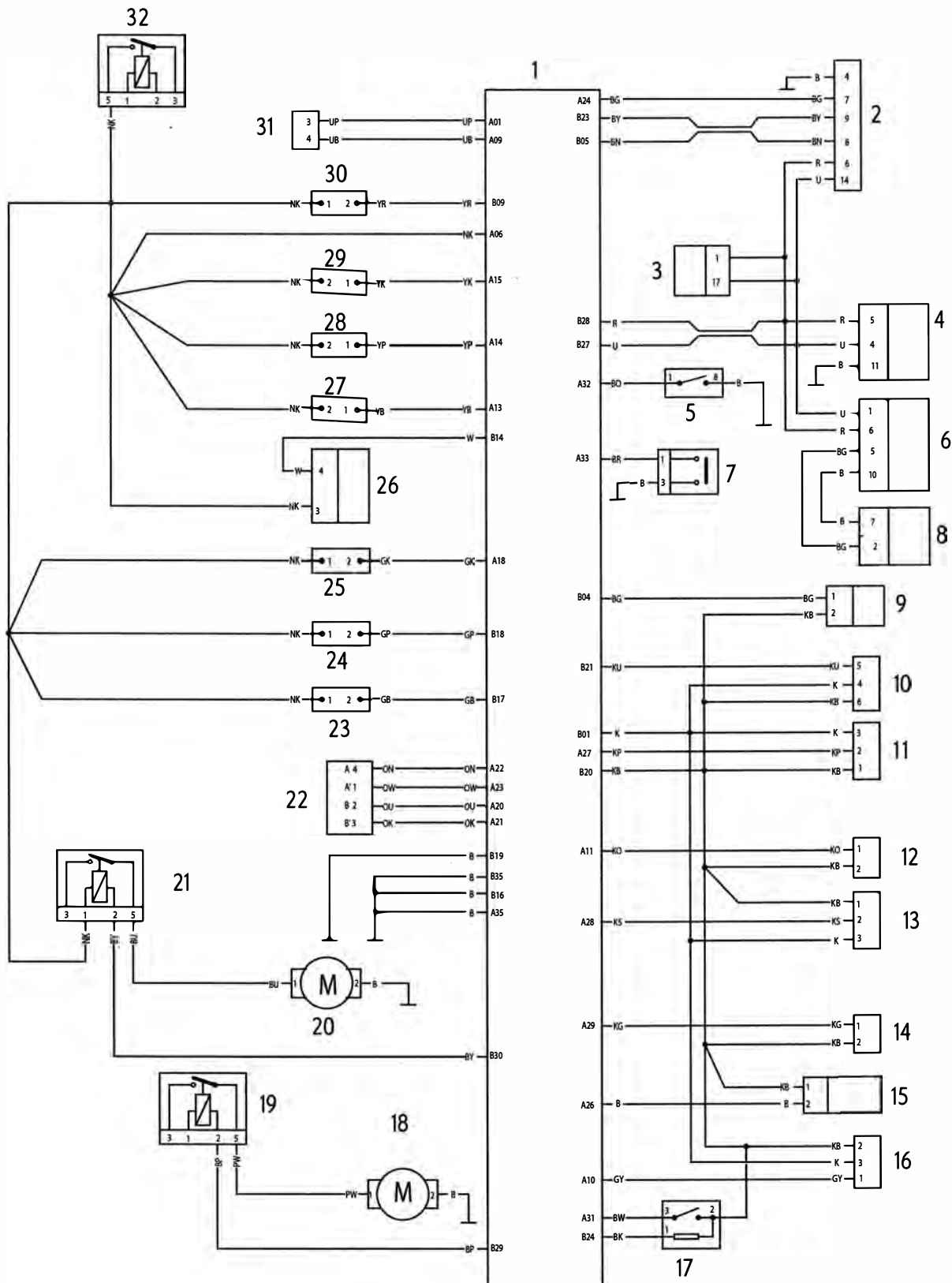

# Electrical

## Complete System - Tiger 800 and Tiger 800XC - without ABS

### Key to circuit diagram

Key	Item Description
1	Instrument Assembly
2	Road Speed Sensor
3	Front Brake Switch
4	Engine Stop Switch
5	Start Switch
6	Engine Control Module
7	Oxygen Sensor
8	Oil Pressure Switch
9	Coolant Temperature Sensor
10	Crankshaft Position Sensor
11	Purge Valve
12	Injector 3
13	Injector 2
14	Injector 1
15	Fuel Level Sender
16	Fall Detection Switch
17	Intake Air Temperature Sensor
18	Throttle Potentiometer
19	Ambient Pressure Sensor
20	MAP Sensor
21	Heated Grips
22	Engine Control Module Relay
23	Gear Position Sensor
24	Fuel Pump Relay
25	Coil 3
26	Coil 1
27	Cooling Fan Relay
28	Coil 2
29	Fuel Pump
30	Cooling Fan
31	Sidestand Switch
32	Idle Speed Stepper Motor
33	Ground
34	Diagnostic Connector
35	Rear Brake Switch
36	Rear Right Direction Indicator
37	Rear Light
38	Rear Left Direction Indicator

39	Alarm
40	Starter Motor
41	Starter Solenoid
42	Battery
43	Regulator/Rectifier
44	Alternator
45	Starter Relay
46	Fuse box (Rear)
47	Fuse box (Front)
48	Immobiliser
49	Ignition Switch
50	Headlight Relay
51	Clutch Switch
52	Horn Switch
53	Direction Indicator Switch
54	Pass Switch
55	Headlight Switch
56	Rear Accessory Socket
57	Front Accessory Socket
58	Front Left Direction Indicator
59	Left Hand Headlight
60	Right Hand Headlight
61	Sidelight
62	Horn
63	Front Right Direction Indicator
64	Direction Indicator Relay
65	Accessory Lights



# Complete System - Tiger 800 and Tiger 800XC - without ABS

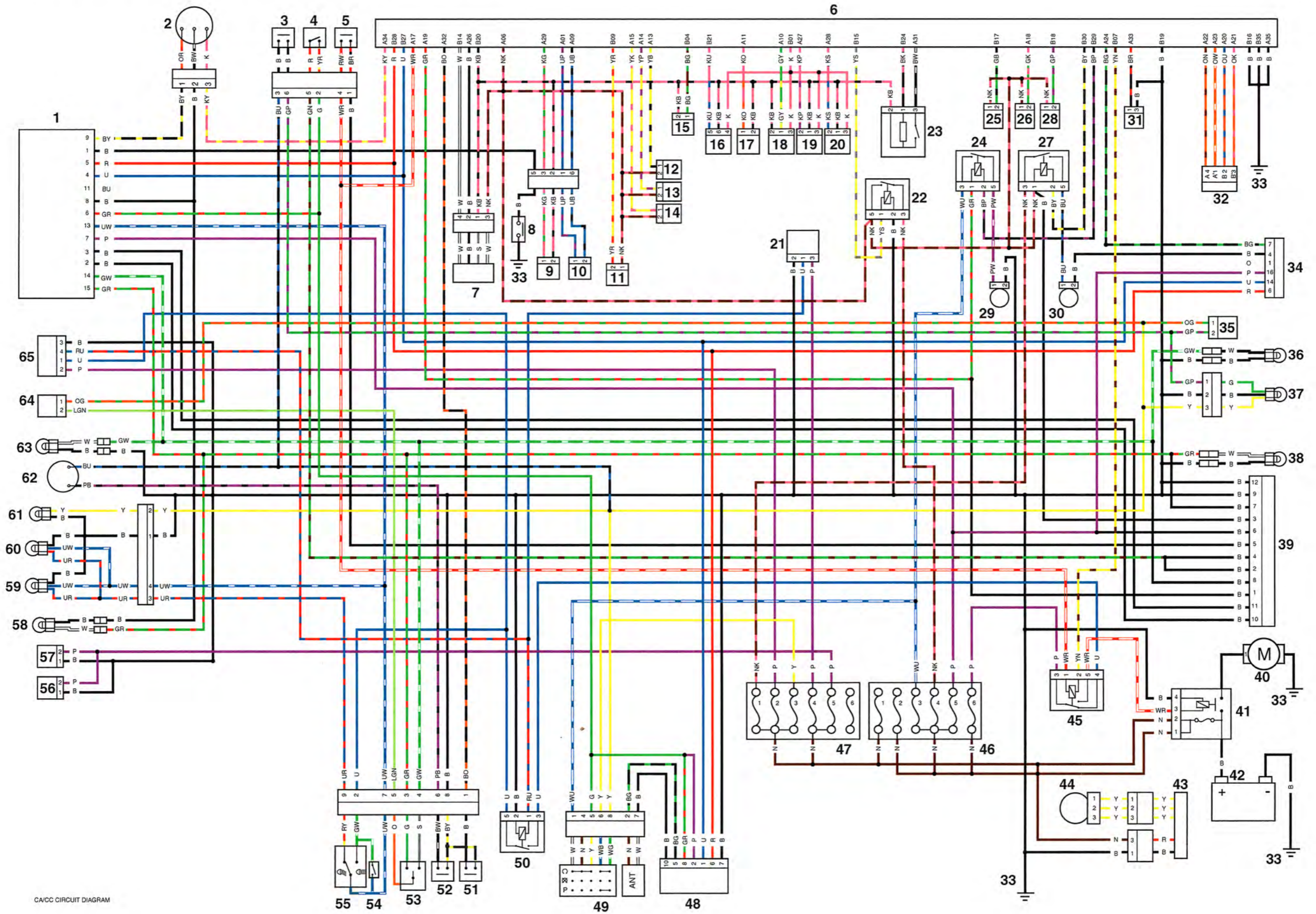

CA/CC CIRCUIT DIAGRAM

# Electrical

## Complete System - Tiger 800 and Tiger 800XC - with ABS

### Key to circuit diagram

Key	Item Description
1	Instrument Assembly
2	Accessory Lights
3	Front Brake Switch
4	Engine Stop Switch
5	Start Switch
6	Engine Control Module
7	Oxygen Sensor
8	Oil Pressure Switch
9	Coolant Temp
10	Crankshaft Position Sensor
11	Purge Valve
12	Injector 3
13	Injector 2
14	Injector 1
15	Fuel Level Sender
16	Fall Detection Switch
17	Intake Air Temperature Sensor
18	Throttle Potentiometer
19	Ambient Pressure Sensor
20	MAP Sensor
21	Heated Grips
22	Engine Control Module Relay
23	Gear Position Sensor
24	Fuel Pump Relay
25	Coil 3
26	Coil 1
27	Cooling Fan Relay
28	Coil 2
29	Fuel Pump
30	Cooling Fan
31	Sidestand Switch
32	Idle Speed Stepper Motor
33	Ground
34	Diagnostic Connector
35	Rear Brake Switch
36	Rear Right Direction Indicator
37	Rear Light
38	Rear Left Direction Indicator

39	Alarm
40	Starter Motor
41	Starter Solenoid
42	Battery
43	Regulator/Rectifier
44	Alternator
45	Starter Relay
46	Fuse box (Rear)
47	Fuse box (Front)
48	Immobiliser
49	Ignition Switch
50	Headlight Relay
51	Clutch Switch
52	Horn Switch
53	Indicator Switch
54	Pass Switch
55	Headlight Switch
56	Rear Wheel Speed Sensor
57	Front Wheel Speed Sensor
58	ABS Module
59	Rear Accessory Socket
60	Front Accessory Socket
61	Front Left Direction Indicator
62	Left Hand Headlight
63	Right Hand Headlight
64	Sidelight
65	Horn
66	Front Right Direction Indicator
67	Direction Indicator Relay

Complete System - Tiger 800 and Tiger 800XC - with ABS

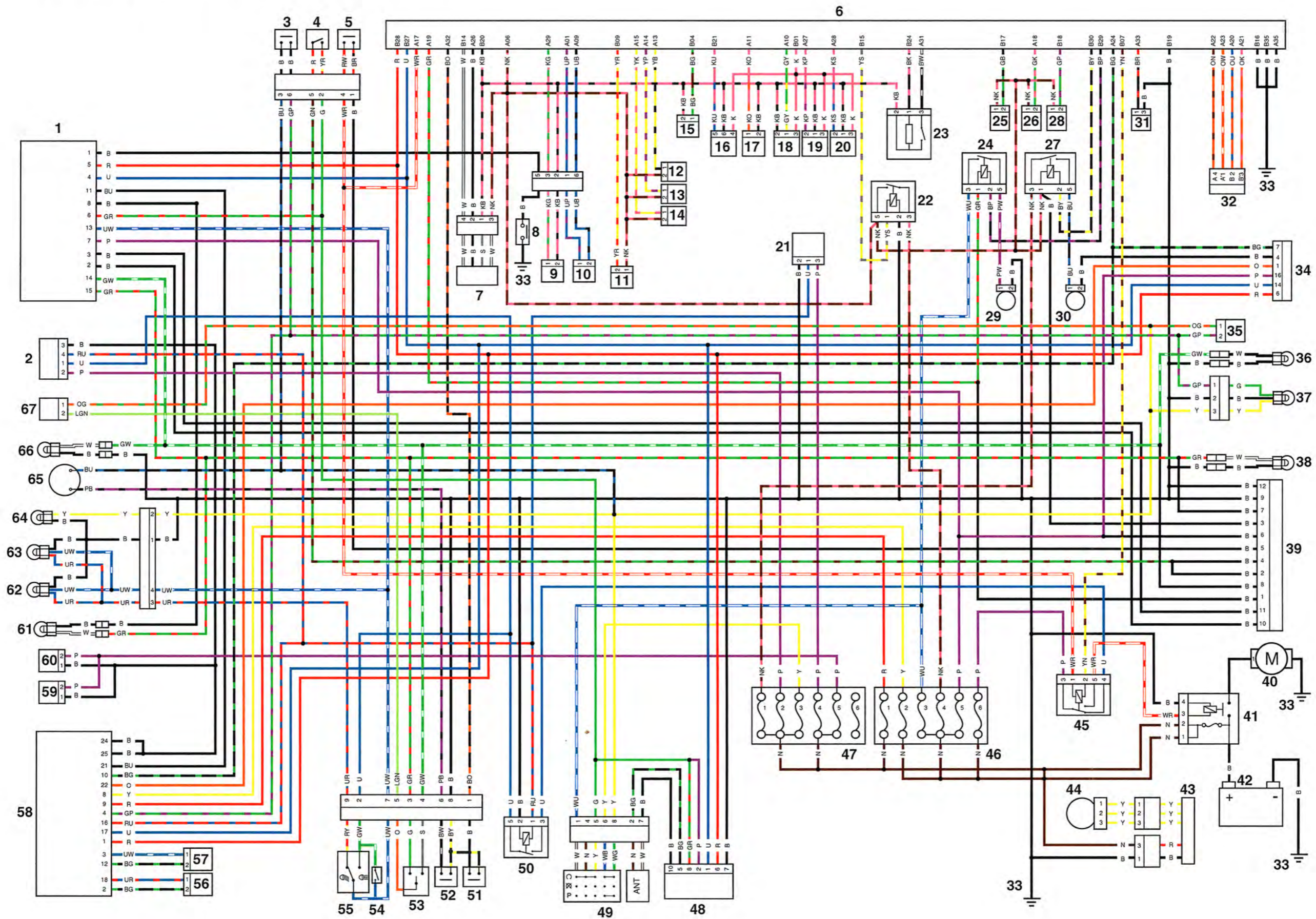

This page intentionally left blank